

Home

Guide 2026
Products and Systems

Contents

CLIVET

HEAT PUMPS

ACCESSORY PRODUCTS FOR HEAT PUMPS

FAN COILS

HEAT PUMPS FOR DHW (Domestic Hot Water)

CONTROLLED MECHANICAL VENTILATION WITH RECOVERY

COMFORT AND ENERGY MANAGEMENT SOLUTIONS

This document is printed every year and presents all Clivet's products with the aim of providing a basis for decisions and evaluations.

More detailed and systematically updated information is available in the "PRODUCTS" section of www.clivet.com and on the Clivet Apps, which can be downloaded for free from the App Store and Google Play

Clivet

53.500 m²

of plants between Feltre (Belluno) and Verona (AHU production)

8

Branches: Great Britain, Germany, India, Russia, UAE, China, Balkans and France

1000+

employees in Italy and abroad

2023

The first sustainability report

Sales

100+

countries we export to

700+

Professionals worldwide

- Sales network
- Distributors and wholesalers
- Installers
- Service Centres

Midea

2016

STRATEGIC ALLIANCE WITH MIDEA GROUP

2024

Midea Group

53,12 BN € of Midea Turnover

277 Fortune Global 500

MBT Climate

2025

MBT Climate, the European umbrella organisation of Midea Building Technologies (MBT), is born



Everything we do, we do
because we believe that a
comfortable world
is a free world.

We create spaces where people can truly
feel free at home, at work, everywhere.

Our HVAC solutions deliver seamless
comfort, so natural it disappears.
You're left free to focus, create, and simply
be.

Because when you're comfortable you're
free.
And that's everything.



Our vision

Comfort for the planet
and people.



Our mission

Blending natural comfort
into life through innovation.

How do our solutions create natural comfort?

They respect the environment, being designed for purity and minimal impact.

They fit everywhere, integrating easily into any context.

They are simple by nature, combining intuitive comfort and maximum ease of use.

They are designed for maximum efficiency, optimising performance and reducing consumption.

The values that guide us

We're life-friendly above all else.

We listen, collaborate, and design thoughtful solutions that generate value and meet people's needs across our entire ecosystem.

We honour our roots and lead by example.

We view our origins and local values as unique strengths that we will always uphold.

Led by ambition, anchored in integrity.

A strong ambition for innovation and growth drives us without compromising our values.

Strive for efficiency to provide simplicity.

We believe that efficiency is key to making life easier and more viable.

New products

CLIVET



FULLNESS



SINERGY2



AQUA F 100 L



AQUA F 190 - 300 L

1.3 New products



EDGE PRO



EDGE PRO L



LARICE MP

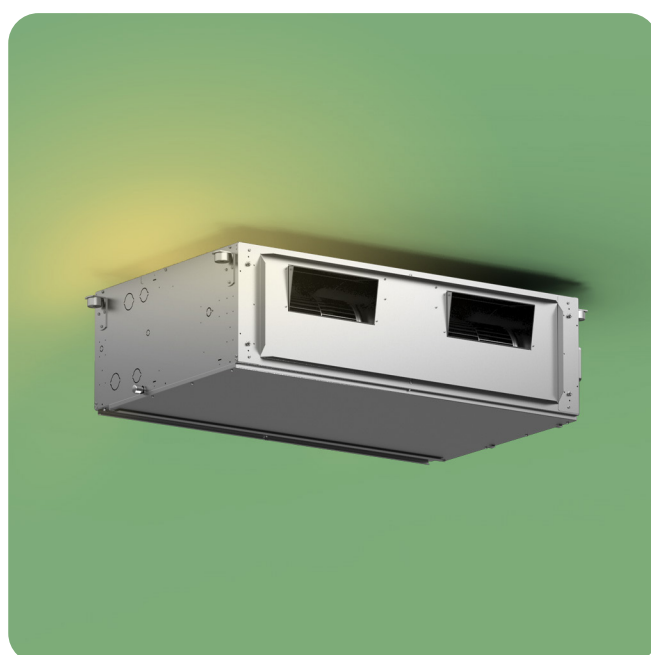

LARICE HP

Technologies for a complete proposal

Heating, cooling, air renewal and domestic hot water production

CLIVET

APPLIED



Hydronic

HOME

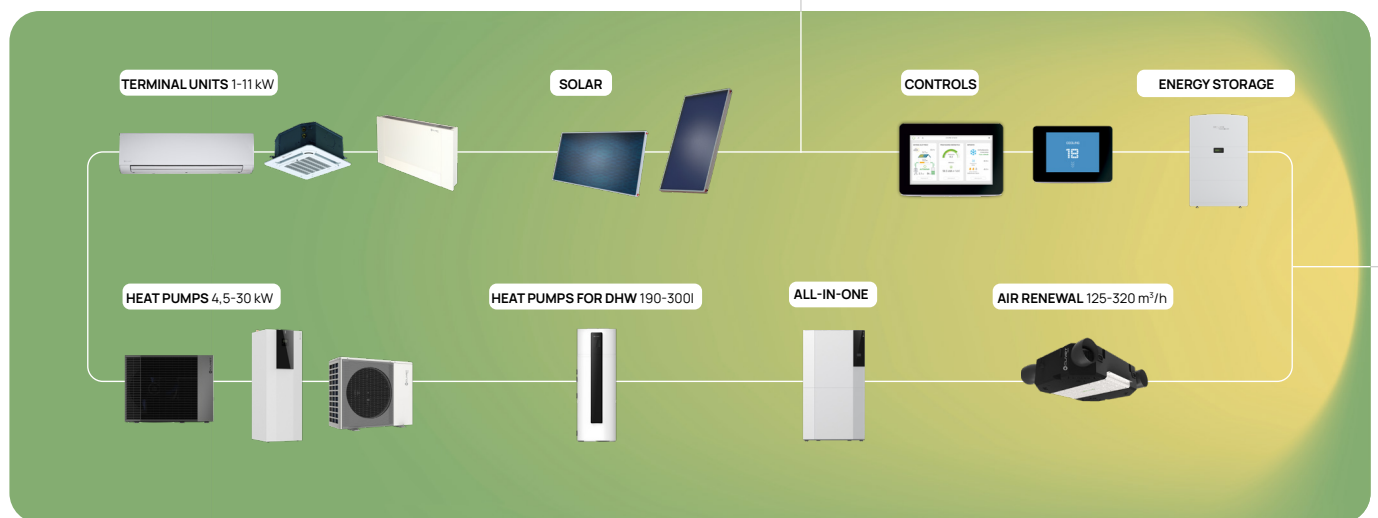

AIR RENEWAL

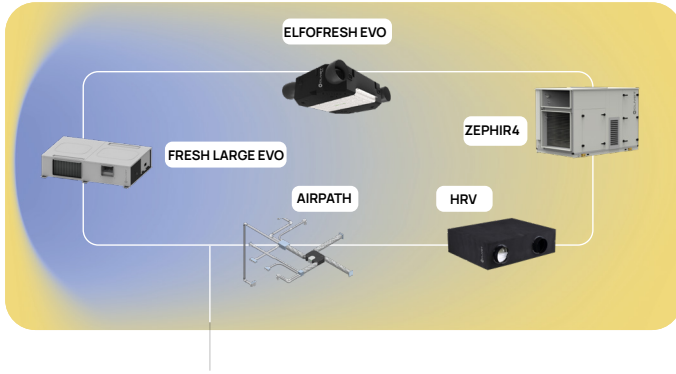

DIGITAL SOLUTION



VRF



Direct expansion

SPLIT

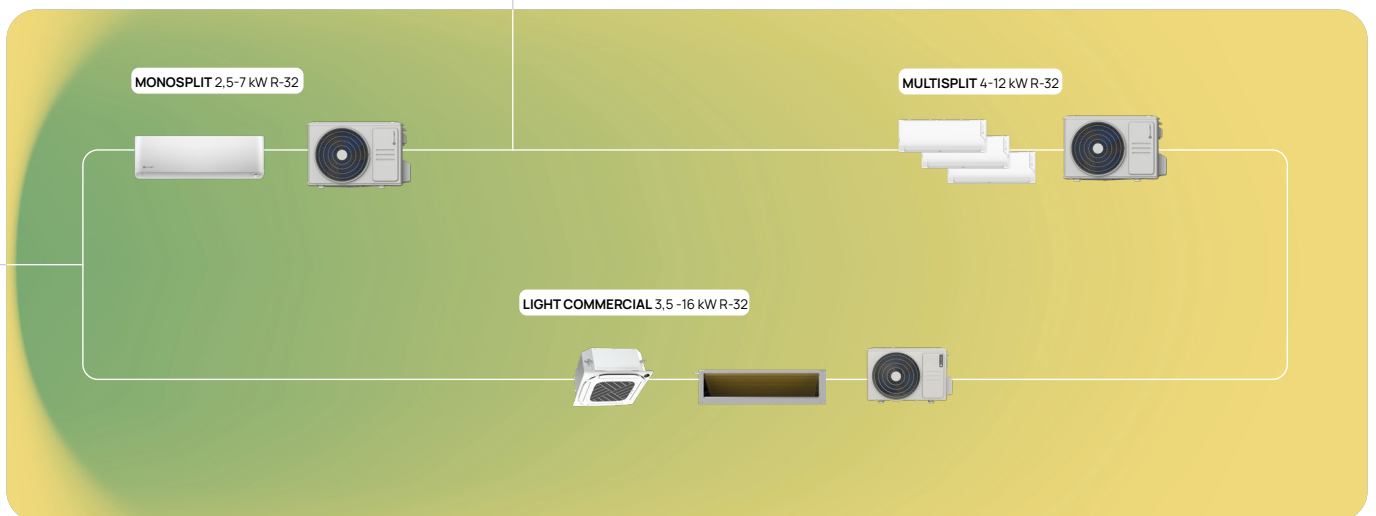

Available only in some countries: please check with our sales team if Clivet direct expansion VRF and SPLIT systems are available in your country.



They optimise the solution based on the needs of the various applications and integrate it in specialised products and in complete dedicated systems:



With the aim of providing Customer satisfaction, Clivet S.p.A. has supplemented and certified its Quality, Environment and Safety Management Systems, in accordance with the ISO 9001, ISO 14001 and ISO 45001 International Standards.



Clivet is committed in promoting the green building principles and has become a member of GBC Italia. This organization collaborates with GBC Italia,, the U.S. nonprofit organization that promotes worldwide the LEED® system of independent certification.

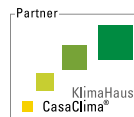

In 2015, Clivet became a partner of CasaClima, as a result, Clivet is now part of a network of companies renowned for their technical expertise and constant focus on sustainable home management. Where applicable.

1.5 Certifications



KEYMARK is a mark recognized in many European countries for the provision of incentives for the installation of heat pumps for room heating and the production of domestic hot water.

The countries that recognize the mark and the Certified Products are available on

<https://keymark.eu/en/products/heatpumps/heat-pumps>

Where applicable.



Clivet participates in the EUROVENT "Liquid Chilling Packages and Hydronic Heat Pumps", "Rooftops", "Air Handling Units", "Fan Coil Units" and "VRF" Certification programmes. The products concerned feature in the EUROVENT guide to certified products and on the website www.eurovent-certification.com. The programmes cover up to the limits set by the purpose of each programme.

Where applicable.



The wide range of Clivet products and complete systems comply with the requirements of the implementing measures for ErP (Energy related Products) Directives 2009/125/EC (Eco-design) and 2010/30/EU (Energy labelling), whose purpose is to reduce the energy consumption of products for heating, cooling, ventilation and hot water production, encouraging the user towards energy-efficient choices.

Directives 2009/125/EC and 2010/30/EU include the following Regulations: (EU) 206/2012, (EU) 626/2011; (EU) 811/2013, (EU) 812/2013, (EU) 813/2013, (EU) 814/2013; (EU) 1253/2014, (EU) 1254/2014; (EU) 2016/2281.



Clivet is involved in the BEYOND GREEN project to promote sustainability and the circular economy together with the other members of SAFE, the consortium system for the circular economy which works to raise public awareness regarding environmental issues, management and valorisation waste, education and training on environmental protection, research on environmental protection.





Home

New builds

Building and system working together as one

Solutions designed to be fully integrated into the configuration of each house, following specific requirements that may depend on the climate, the need for mechanical ventilation or dehumidification, structural insulation, the presence of renewable sources and much more.

These systems are complete and highly customisable: they are already conceived at the design stage to not only fulfil Heating, Cooling and Domestic Hot Water production, but also Ventilation, Air renewal and heat recovery. They are also optimised to provide maximum efficiency and quiet operation, as well as the lowest possible consumption levels.

- SPHERA EVO 2.0
- SPHERA EVO 2.0 Invisible
- Edge EVO 2.0
- EDGE F
- EDGE PRO
- EDGE PRO L
- Hydro-Split TOWER/INVISIBLE Version
- ELFO^{Sun3}
- ELFOFresh EVO
- AQUA F
- FULLNESS

Renovations

Turn your ideas into reality and create comfort

Solutions designed to enhance systems in existing houses by also intervening on the distribution and control system, which require building works such as renovating the distribution system, installing an intelligent management system or creating a thermal cladding system. Incentives make these interventions extremely cost-effective, even with low investments.

These are cutting-edge systems that significantly increase comfort levels: they are designed at the renovation stage to replace the Heating system and the production of Domestic Hot Water, but also to add cooling, renewable energy sources (e.g. solar panels) or intelligent management systems such as CONTROL4 NRG.

- SPHERA EVO 2.0
- SPHERA EVO 2.0 Box
- SPHERA EVO 2.0 EASYHybrid Tower
- Edge EVO 2.0
- EDGE F
- EDGE PRO
- EDGE PRO L
- Hydro-Split TOWER/BOX Version
- Edge EVO 2.0 Versione Hybrid
- ELFOSUN³
- ELFOFresh EVO

Replacements

Get maximum results with minimum effort

Solutions designed to update old generators without modifying the system, using stage-of-the-art products that require similar overall dimensions and no significant masonry works. Incentives and extremely quick intervention times clearly make this an obvious choice.

These systems are very versatile and can adapt to any existing facilities: they simply replace the generator that provides Heating and Domestic Hot Water, improving comfort and efficiency, as well as ensuring peace of mind.

- SPHERA EVO 2.0 Box
- SPHERA EVO 2.0 EASYHybrid Box
- SPHERA EVO 2.0 EASYHybrid Tower
- SPHERA EVO 2.0 Box Hybrid
- Edge EVO 2.0
- EDGE F
- EDGE PRO
- EDGE PRO L
- Hydro-Split TOWER /INVISIBLE / BOX Version
- AQUA F

1

All-in-one

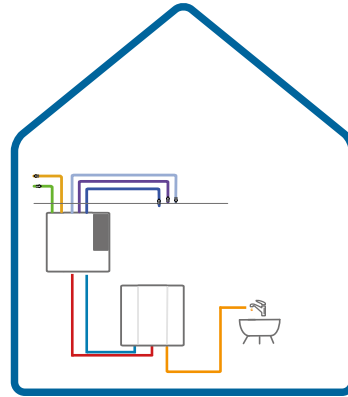

This versatile system features two indoor units: an air-to-air heat pump and a domestic hot water storage tank. Their design allows for customized installation—either stacked or side-by-side—to easily adapt to any space. A major advantage lies in the installation process: the connection between the two modules is purely hydraulic, meaning that F-Gas certification is not required for commissioning.

2

Refrigerant-split

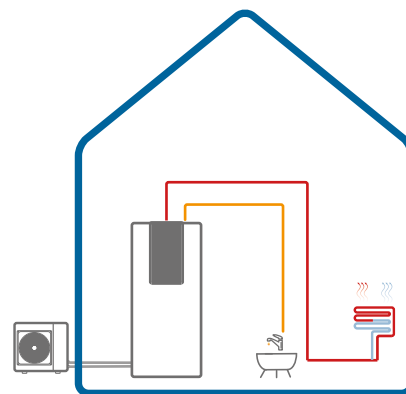

The system consists of an outdoor unit and an indoor unit, which are connected by connections in which refrigerant flows. This type of solution is extremely flexible and guarantees various installation possibilities.

The installation requires an F-GAS licence and is perfect for professionals used to working with systems requiring this type of technology.

3

Monobloc

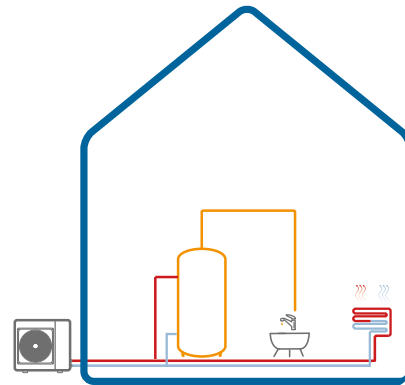

The system consists of an outdoor unit that directly supplies the system through piping in which water flows. This type of solution is plug&play and very easy to install.

The installation does not require an F-GAS licence and is perfect for non-invasive interventions on the building.

4

Hydro-split

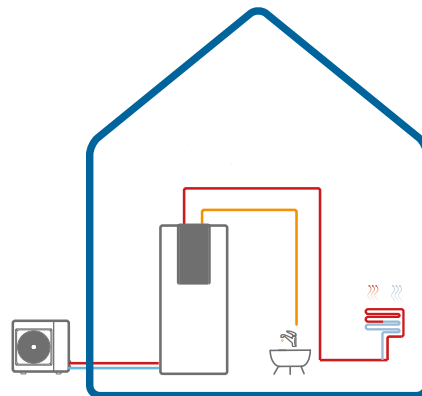

The system consists of an outdoor unit and an indoor unit, which are connected by hydraulic connection in which water flows. This type of solution is complete and very easy to install, while still being highly versatile.

The installation does not require an F-GAS licence and is a good compromise between plug&play systems and more complex installations.

Heat pumps



Refrigerant-split

	SPHERA EVO 2.0		4 ÷ 16 kW
	SPHERA EVO 2.0 BOX		4 ÷ 16 kW
	SPHERA EVO 2.0 INVISIBLE	 Integr. boiler (optional)	4 ÷ 10 kW 24 kW (boiler)
	SPHERA EVO 2.0 EASYHybrid BOX	 Integr. Boiler	4 ÷ 16 kW 24 ÷ 34 kW (boiler)
	SPHERA EVO 2.0 EASYHybrid TOWER	 Integr. Boiler	4 ÷ 16 kW 24 ÷ 34 kW (boiler)

Monobloc

	EDGE PRO		4 ÷ 16 kW
	EDGE PRO L		25 ÷ 30 kW
	EDGE F		4 ÷ 15 kW
	EDGE EVO 2.0 - EXC		4 ÷ 30 kW



HYDROSplit

	Version TOWER ^{NEW}	 (optional)	4 ÷ 16 kW
	Version BOX ^{NEW}	 (optional)	4 ÷ 16 kW
	Version INVISIBLE ^{NEW}	 (optional) Integr. boiler (optional)	4 ÷ 10 kW 24 ÷ 34 kW (boiler)
	Version MINI ^{NEW}	 (optional)	4 ÷ 16 kW

ALL-IN-ONE

	FULLNESS		5 kW
--	----------	--	------

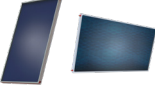
Accessory products for heat pumps

	Boilers for domestic hot water	200 ÷ 1.000 l
	ELFOS#UN# ^{3#} - thermal solar	2 ÷ 2,5 m ²
	Gas Boiler FE	24 ÷ 34 kW
	Gas Boiler UC	34 ÷ 200 kW





Fan-coils



	MOOD	 DC Motor	2,7 ÷ 4,9 kW
	ELFOROOM ²	 DC Motor	0,9 ÷ 3,7 kW
	AURA	 AC Motor	1,5 ÷ 8,3 kW
	ELFOSPACE BOX3	 DC Motor	3,0 ÷ 11,2 kW
	LARICE		

Heat pumps for domestic hot water



	AQUA F 100 L	 R-290	100
	AQUA F 190-300 L	 R-290	190-300

Controlled Mechanical Ventilation with recovery



CLIVET



ELFOFRESH EVO



Full Inverter DC

125 + 320 m³/h

Comfort management solutions



HID-TConnect²

-



CONTROL4 NRG

-



SINERGY2 - Photovoltaic storage system

5 + 20 kWh

ALL-IN-ONE



2.1 Heat pumps



FULLNESS

HEAT PUMPS

FULLNESS

Reversible air-to-air heat pump, monobloc unit with dual ducting for heating, cooling, air renewal and domestic hot water

HEAT PUMPS

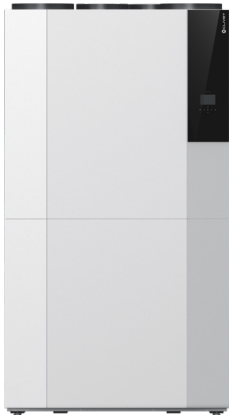

Comfort



Hot
Cold



DHW



Silent

Energy saving



Free Cooling /
Heating

Convenience



Integrated DHW
tank

Management and connectivity



Modbus port



Control via the
App



CONTROL4 NRG
management



Clivet Eye
monitoring

Health



High Density
filter



Air renew



Air purification

- ✓ Heating and cooling
- ✓ Constant Air Renewal
- ✓ High-Efficiency Air Filtration
- ✓ Heat Recovery on Domestic Hot Water
- ✓ Modular solution for simplified installations.

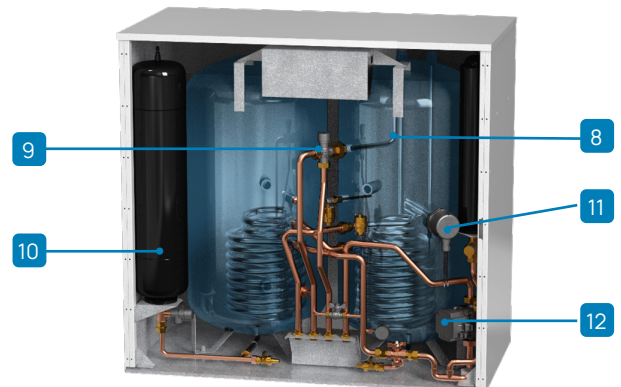
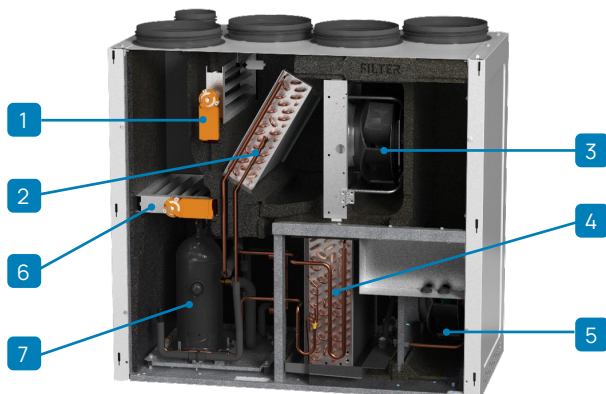

Power tailored to your home

Each house is unique. With a capacity exceeding 5 kW, Fullness is the ideal solution for both modern homes of 70 m² and high energy-efficient buildings, such as passive houses, of up to 180 m².

Fullness is not just a heat pump. It is the invisible heart of a modern home: more efficient, healthier and more beautiful. Choose simplicity, choose total well-being.

Configurations

VERSION:

- PDCATA Standard Unit, Air-to-Air Heat Pump, and Air Renewal
- PDCATAR Air-to-Air heat pump unit, renewal and heat exchanger for domestic hot water
- FIFD Electronic filter with iFD technology, offering 90% efficiency on PM1.

CONTA5

Device for monitoring the energy released to the environment and the energy consumed.

Accessories



MAS200X

200-litre DHW tank module for all-in-one units

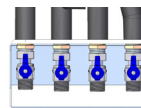

VIRX

Shut-off valves

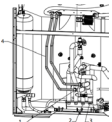

KTCATX

Technical water connection pipe kit with stacked units

- 1 Recirculation damper
- 10 15l DHW expansion vessel
- 2 Supply heat exchanger
- 11 DHW back-up heater
- 3 Supply fan
- 12 DHW pump
- 4 Extraction heat exchanger
- 5 Exhaust fan
- 6 Fresh air damper
- 7 Inverter compressor
- 8 Domestic hot water tank
- 9 Thermostatic anti-scald valve

Technical data

Size		3.1			
Ventilation	Adjustable Supply Air Flow Rate	Minimum / Maximum	m ³ /h	400 - 800	
	Source-Side Air Flow Rate	Minimum / Maximum	m ³ /h	600 - 1200	
	Available pressure	Water content	Pa	4,70 / 4,99	
	Adjustable Fresh Air Flow Rate	Minimum / Maximum	m ³ /h	3,10	
	Filters type	-	-	4,30 / 5,96	
	Filtration class	-	-	3,80	
Heating	Heating capacity	Ambient air 20 °C/50% UR Outdoor air 7 °C/6 °C WB	Nominal	kW	5.21
	COP		Nominal	-	3,13
	Heating capacity	Ambient air 20 °C/50% UR Outdoor air -5 °C/80% UR	Nominal	kW	5.00
	COP		Nominal	-	2,34
Cooling	Cooling capacity	Ambient air 26 °C/50% UR Outdoor air 35 °C/50% UR	Nominal	kW	5.00
	EER		Nominal	-	2,46
DHW	Net tank capacity		l	200	
	Mixed Water at 40°C (V40)lpl1lpl1		l	231	
	Heating time		h:min	02:36	
Electrical Power for Meter Sizing (Heat Pump Only)			kW	3,08	
Electrical Power for Meter Sizing (Heat Pump + DHW Module only, with Boost Function)			kW	5,08	
Seasonal efficiency Medium climate	Heating Air 7 °C	Energy class	-	TO	
		Annual energy consumption	kWh	2227	
		SCOP	-	2,90	
	Cooling Air 35 °C	nsh (seasonal efficiency)	%	113	
		Energy class	-	B	
		Annual energy consumption	kWh	1144	
		SEER	-	3,79	
	DHW	nsc (seasonal efficiency)	%	148,5	
		Energy class	-	B	
		Withdrawal profile	-	XL	
Power supply	Voltage/Frequency/Phases		V/Hz/n°	230/50/1	
Expansion Vessel Capacity			l	15	
Sound power	Silent / Maximum		dB(A)	50 / 55	
Sound pressure @1 m	Silent / Maximum		dB(A)	40 / 45	
Operating range					
Operating range (Indoor air)	Heating	Minimum / Maximum	°C	15 / 30	
	Cooling	Minimum / Maximum	°C	16 / 35	
Operating range (outdoor air)	Heating	Minimum / Maximum	°C	-20 / 35	
	Cooling	Minimum / Maximum	°C	16 / 45	

Data calculated in accordance with EN 14511:2022, with reference to an available pressure of 50 Pa

Dimensions and connections

Size		3.1	
Heat pumps dimensions	AxCxB	mm	1.078x1100x599
Operating weight		kg	150
DHW modul dimensions	AxCxB	mm	1.029x1100x600
Operating weight		kg	360
Refrigerant charge		type / GWP	R-454C / 148
		kg	0,85
		CO ₂ tons	0,13
External diameters	Room supply	mm	250
	Outdoor air return	mm	250
	Room recirculation	mm	250
	Exhaust air	mm	250
	Stale air extraction	mm	150
	Condensate drain	mm	16
	Water connections	inch	3/4"
	DHW connections	inch	3/4"

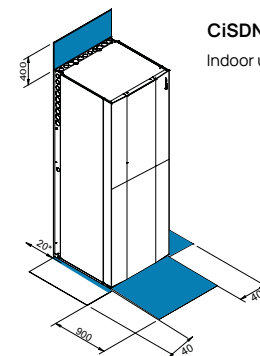

CiSDN-M EP 1 MR 3.1
Indoor unit (IDU)

For trouble-free operation of the unit it is essential to maintain the safety distances indicated by the blue areas

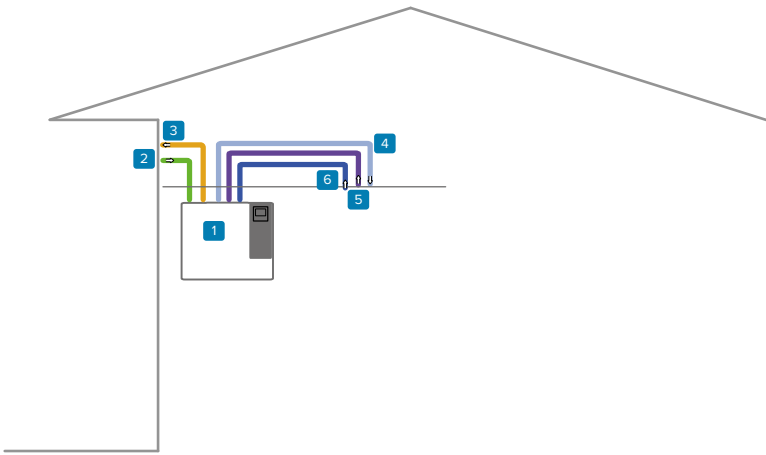

- 1 Heat pump module
- 2 Outdoor air return
- 3 Exhaust air
- 4 Indoor air distribution
- 5 Bathroom and kitchen air extraction
- 6 Neutral air recirculation from the corridor

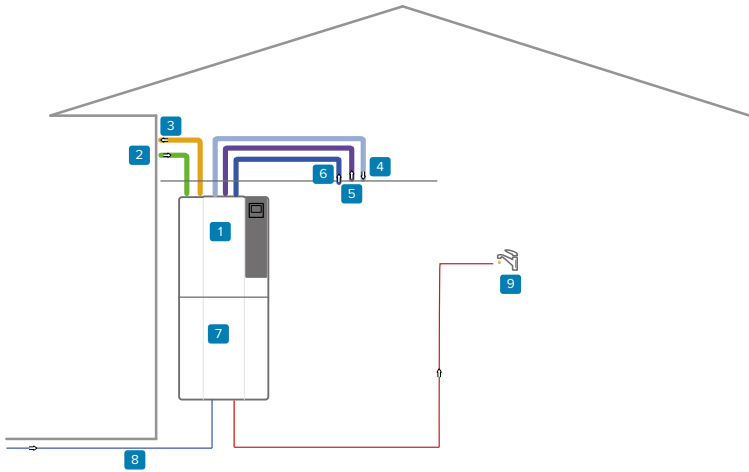

- 1 Heat pump module
- 2 Outdoor air return
- 3 Exhaust air
- 4 Indoor air distribution
- 5 Bathroom and kitchen air extraction
- 6 Neutral air recirculation from the corridor
- 7 DHW module
- 8 Water system
- 9 DHW distribution

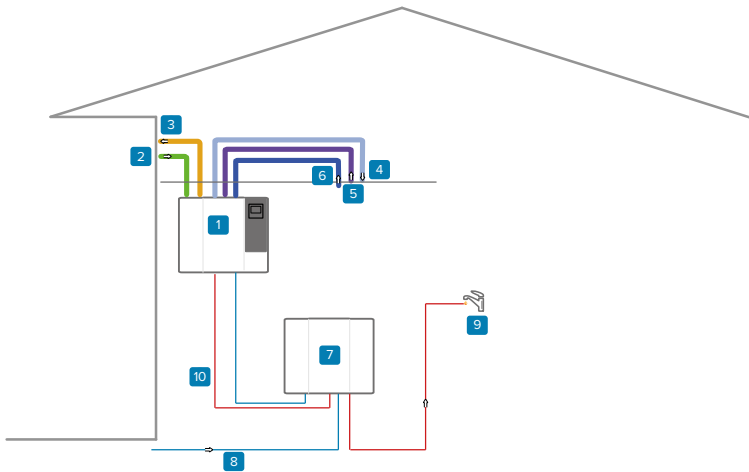

- 1 Heat pump module
- 2 Outdoor air return
- 3 Exhaust air
- 4 Indoor air distribution
- 5 Bathroom and kitchen air extraction
- 6 Neutral air recirculation from the corridor
- 7 DHW module
- 8 Water system
- 9 DHW distribution
- 10 Hydraulic connection between the two modules

REFRIGERANT SPLIT

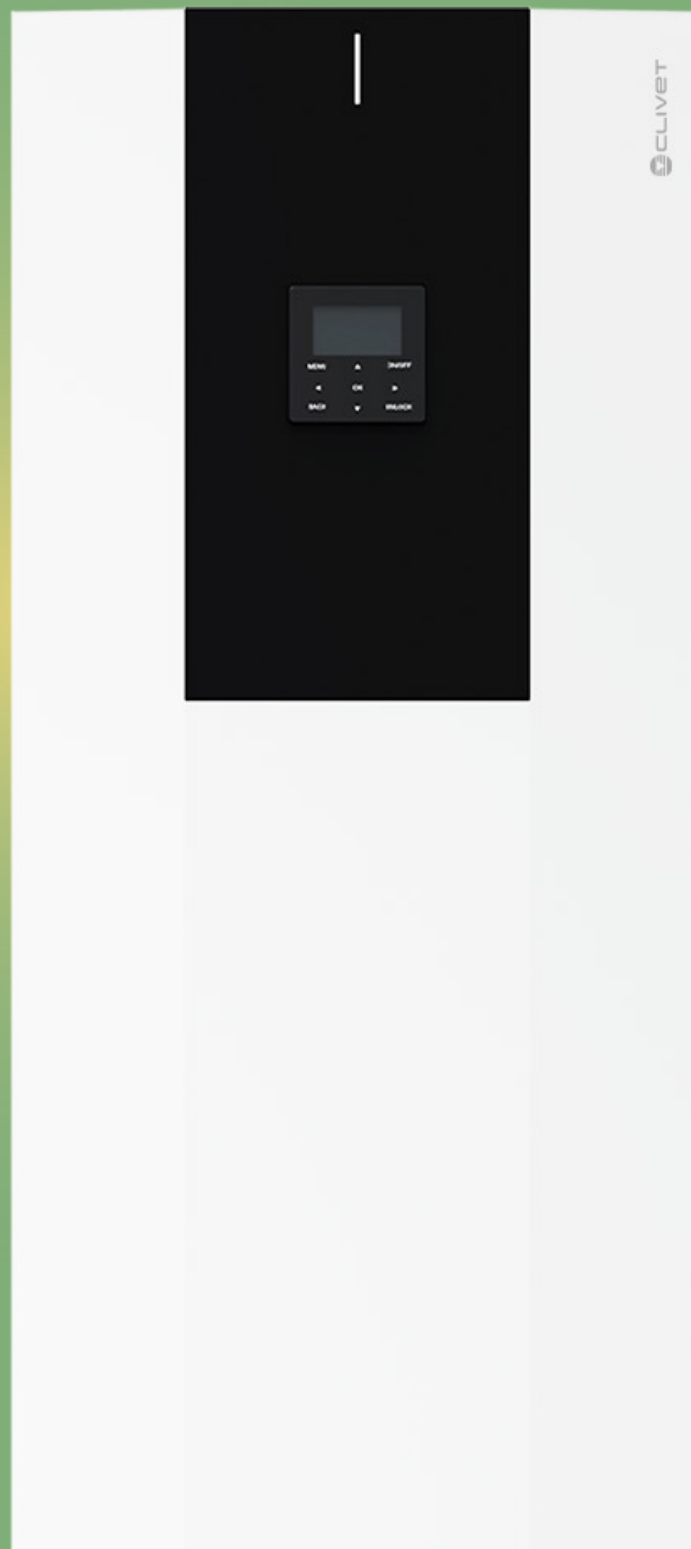

2.1 Heat pumps

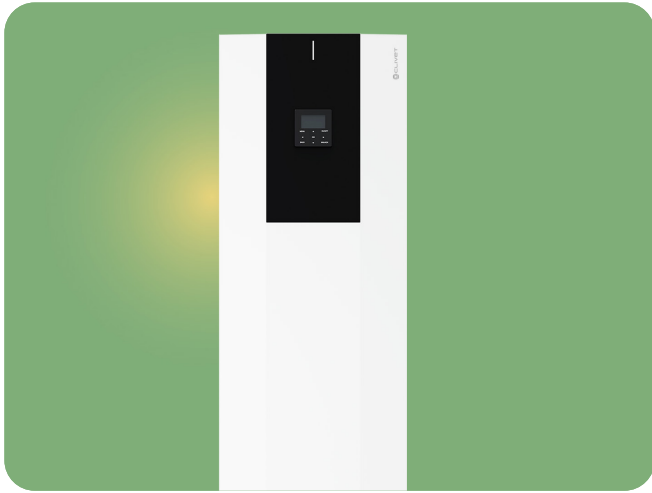

SPHERA EVO 2.0



SPHERA EVO 2.0 BOX



SPHERA EVO 2.0 INVISIBLE



SPHERA EVO 2.0 EASYHYBRID BOX



SPHERA EVO 2.0 EASYHYBRID TOWER

SPHERA EVO 2.0

Air-to-water Refrigerant-split heat pump with DHW tank for heating, cooling and domestic hot water production

Capacity from 4 to 16 kW



HEAT PUMPS

Energy saving



Solar integration (DHW tank - optional)



Cascade



Smart Grid ready



€-Switch



Hot Cold



DHW



Silent



Backup heater (optional)



Products Quality Casa Clima



025



Renewable Energy (Full electric version)

Comfort

Reliability

Health

Management and connectivity



Input ON/OFF



Port Modbus



Control via App



management Control4 NRG



User interface / thermostat



Clivet Eye monitoring

Convenience



Weekly Timer



Instant DHW (Hybrid Version)



Contemporaneity (Hybrid Version)



Integrated DHW tank



- ✓ Energy efficiency at the highest level
- ✓ Designed not to disturb, operating very quietly
- ✓ Suitable for every need, thanks to the dual version with 190-litre or 250-litre DHW storage tank
- ✓ Compact outdoor unit requiring very little installation space
- ✓ Simultaneous operation in system and DHW (Hybrid version)

- 1 Inverter DC fan
- 2 Inverter DC twin-rotary compressor
- 3 Air-gas finned exchanger (blue fin treatment)
- 4 Gas/water plate exchanger
- 5 Inverter DC high efficiency pump
- 6 12-litre system expansion tank
- 7 3-way valve
- 8 Magnetic dirt separator filter
- 9 190L/250L DHW tank with coil

- 10 2 kW DHW safety heater
- 11 15-litre inertial tank

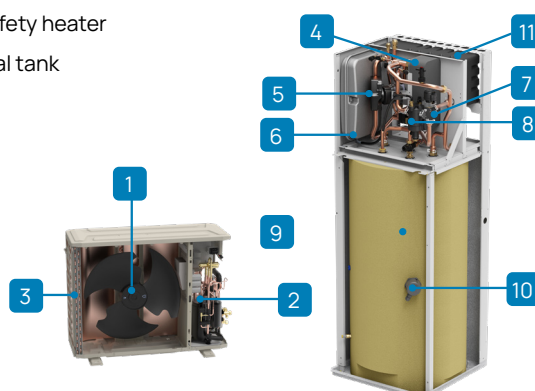

Everything under control

The discreet and effective warning LED on the front of the unit indicates the unit's operating status in real time. If the LED is pulsing white the unit is in stand-by or operating normally, if the LED is orange with quick pulsing there is a fault.

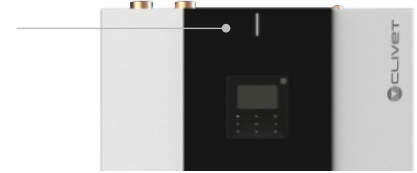

Configurations

DHW STORAGE TANK:

ACS190	190 liter DHW tank
ACS250	250 liter DHW tank

Note: there is no standard configuration

OUTDOOR UNIT power supply (size 6.1+8.1):

220M	Power supply 230/1/20 (standard)
400TN	Power supply 400/3/50+N

BACK-UP ELECTRIC HEATER (integrated in the unit):

-	No heater (standard)
EH024	2/4 kW back-up heater
EH6	6 kW back-up heater
EH9	9 kW back-up heater

Accessories

	SOLX	Thermal solar management kit		APAVX	Kit of antivibration mounts for floor installation
	KCSX	Kit for secondary circuit (1 liter circuit breaker + circulation pump)		ASTFX	Antivibration mounts kit for installation on the brackets for wall installation or drain pan
	KIRE2HLX	Two-zone distribution kit: direct + mixed		KSIPX	Kit with wall fixing brackets
	KIRE2HX	Double zone distribution unit: direct + direct		HTC2WX	White HID-TConnect2 chronothermostat for temperature control
	ACI40X	40 liter system inertial storage tank		SWCX	Receiver / IoT switch SwitchConnect
	DI50-2X	50 liter hydraulic separator		VEACSX	Sanitary expansion tank
	COFX	Aesthetic cover for inertial storage tank		KTCTX	Top outlet connection piping kit Compatible only with standard version
	T1BX	10m water temperature probe		KTCSX	Left outlet connection piping kit Compatible only with standard version Not compatible with KTCSTX option
	T1B30X	30m water temperature probe		KTCRX	Right outlet connection piping kit Compatible only with standard version
	VDACSX	Thermostated diverter valve for DHW		KTCSTX	Solar circuit top connection kit Compatible only in the presence of option SOLX, not compatible with KTCSX.
	DTX	Drain pan with antifreeze electrical heater			

Technical data

Size - Set				2.1		3.1		4.1		5.1		6.1		7.1		8.1	
DHW tank				190L	250L	190L	250L	190L	250L	190L	250L	250L	250L	250L	250L	250L	250L
Heating	Capacity	Water 35/30 °C	Nominal / Maximum	4,32 / 6,26		6,18 / 7,41		8,30 / 9,11		10,1 / 10,3		12,1 / 14,6		14,5 / 15,5		16,0 / 16,8	
	COP	Outdoor air 7 °C	Nominal	5,42		5,21		5,31		5,01		5,00		4,70		4,55	
	Capacity	Water 35/30 °C	Nominal / Maximum	4,17 / 6,25		6,05 / 6,97		7,33 / 8,35		8,20 / 9,30		10,5 / 13,9		12,2 / 14,1		13,4 / 14,3	
	COP	Outdoor air -7 °C	Nominal	3,16		3,00		3,23		3,07		3,13		2,82		2,74	
Cooling	Capacity	Water 45/40 °C	Nominal / Maximum	4,16 / 5,96		6,03 / 7,13		8,22 / 8,98		10,0 / 10,3		12,3 / 14,5		14,0 / 15,7		16,0 / 16,6	
	COP	Outdoor air 7 °C	Nominal	3,93		3,83		3,95		3,86		3,80		3,65		3,60	
	Capacity	Water 18/23 °C	Nominal / Maximum	4,55 / 6,88		6,44 / 7,65		8,10 / 11,1		10,0 / 12,0		12,1 / 15,0		13,8 / 15,3		14,8 / 16,4	
	EER	Outdoor air 35 °C	Nominal	6,08		5,24		5,12		4,77		4,02		3,70		3,65	
DHW	Capacity	Water 7/12 °C	Nominal / Maximum	4,26 / 6,14		6,25 / 6,39		7,46 / 7,94		9,10 / 9,10		11,8 / 11,8		12,9 / 12,9		14,2 / 14,2	
	EER	Outdoor air 35 °C	Nominal	3,50		3,09		3,33		3,09		2,75		2,55		2,45	
	Net tank capacity		l	190	250	190	250	190	250	190	250	250	250	250	250	250	250
	Water mixed at 40 °C (V40) ¹		l	204	269	204	269	204	269	204	269	269	269	269	269	269	269
Electrical power for meter sizing	Heating time		h:min	2:30	2:25	2:30	2:25	2:08	2:05	2:08	2:05	1:46	1:46	1:46	1:46	1:46	1:46
	Power		kW	2,20		2,60		3,30		3,60		5,40		5,70		6,10	
	Energy class		-	A++		A++		A++		A++		A++		A++		A++	
	Annual energy consumption		-	2,519		3,255		3,824		4,749		6,774		7,277		7,825	
Seasonal efficiency Medium climate	SCOP		-	3,35		3,57		3,72		3,73		3,57		3,57		3,52	
	ns (seasonal output)		%	131		140		146		146		140		140		138	
	Energy class		-	A+++		A+++		A+++		A+++		A+++		A+++		A+++	
	Annual energy consumption		-	2,161		2,502		3,141		3,747		4,994		5,868		6,602	
DHW	SCOP		-	5,13		5,15		5,32		5,27		5,00		4,91		4,89	
	ns (seasonal output)		%	202		203		210		208		196		193		193	
	Energy class		-	A+	A+	A+	A+	A+	A+	A+	A+	A+	A+	A+	A+	A+	A+
	Withdrawal profile		-	L	XL	L	XL	L	XL	L	XL	L	XL	L	XL	L	XL
Size - Indoor unit				A	A	A	A	A	A	A	A	B	B	B	B	B	
Power supply	Voltage/Frequency/Phases			V/Hz/n°													
Water flow-rate	Water 35/30 °C	Nominal	l/s	0,21		0,30		0,41		0,49		0,57		0,67		0,75	
Pump available pressure	Outdoor air 7 °C	Nominal	kPa	31,2		36,5		33,1		31,0		25,7		31,7		22,6	
Minimum system water content			l	40		40		40		40		40		40		40	
Expansion tank capacity			l	12		12		12		12		12		12		12	
Sound power		Nominal	dB(A)	41		41		41		41		41		41		41	
Sound pressure @1m		Nominal	dB(A)	26		26		26		26		26		26		26	
Size - Outdoor unit				2.1	3.1	4.1	5.1	6.1	7.1	8.1							
Power supply	Voltage/Frequency/Phases			V/Hz/n°													
Sound power		Minimum / Nominal	dB(A)	50 / 55		51 / 57		52 / 58		52 / 60		54 / 63		54 / 64		54 / 66	
Sound pressure @1m		Minimum / Nominal	dB(A)	37 / 42		38 / 44		39 / 45		39 / 47		41 / 50		41 / 51		41 / 53	
Operating range																	
Water supply temperature	Heating / DHW	Full electric	Minimum / Maximum	°C													
		Hybrid	Minimum / Maximum	°C													
Operating range (Outdoor air)	Cooling	-	Minimum / Maximum	°C													
	Heating	-	Minimum / Maximum	°C													
Operating range (Outdoor air)	DHW	-	Minimum / Maximum	°C													
	Cooling	-	Minimum / Maximum	°C													

Data according to EN 14511:2022 and EN 14825:2022

The Product complies with the European ErP Directive (EU Regulations 811/2013 - 813/2013 - 2016/2281). Energy classes with energy assistant for Clivet Smart Home

(1) Data according to EN 16147: amount of water at 40 °C with the same enthalpy content as the water coming out of the Boiler at a temperature higher than 40 °C

Size - Set (400TN version)				6.1	7.1	8.1	
DHW tank				250L	250L	250L	
Heating	Capacity	Water 35/30 °C	Nominal / Maximum	12,1 / 14,6	14,5 / 15,5	16,0 / 16,8	
	COP	Outdoor air 7 °C	Nominal	5,00	4,70	4,55	
	Capacity	Water 35/30 °C	Nominal / Maximum	10,5 / 13,9	12,2 / 14,1	13,4 / 14,3	
	COP	Outdoor air -7 °C	Nominal	3,13	2,82	2,74	
	Capacity	Water 45/40 °C	Nominal / Maximum	12,3 / 14,5	14,0 / 15,7	16,0 / 16,6	
	COP	Outdoor air 7 °C	Nominal	3,80	3,65	3,60	
Cooling	Capacity	Water 18/23 °C	Nominal / Maximum	12,1 / 15,0	13,8 / 15,3	14,8 / 16,4	
	EER	Outdoor air 35 °C	Nominal	4,02	3,70	3,65	
	Capacity	Water 7/12 °C	Nominal / Maximum	11,8 / 11,8	12,9 / 12,9	14,2 / 14,2	
	EER	Outdoor air 35 °C	Nominal	2,75	2,55	2,45	
DHW	Net tank capacity		l	250	250	250	
	Water mixed at 40 °C (V40) ¹		l	269	269	269	
	Heating time		h:min	1:46	1:46	1:46	
Electrical power for meter sizing			kW	5,40	5,70	6,10	
Seasonal efficiency Medium climate	Energy class		-	A++	A++	A++	
	Heating Water 55 °C	Annual energy consumption		-	6.774	7.277	7.825
		SCOP		-	3,57	3,57	3,52
		ns (seasonal output)		%	140	140	138
	Energy class		-	A+++	A+++	A+++	
	Heating Water 35 °C	Annual energy consumption		-	4.994	5.868	6.602
		SCOP		-	5,00	4,91	4,89
		ns (seasonal output)		%	196	193	193
	DHW	Energy class		-	A+	A+	A+
		Withdrawal profile		-	XL	XL	XL
Size - Indoor unit				B	B	B	
Power supply		Voltage/Frequency/Phases		V/Hz/n°			
Water flow-rate		Water 35/30 °C	Nominal	0,57	0,67	0,75	
Pump available pressure		Outdoor air 7 °C	Nominal	25,7	31,7	22,6	
Minimum system water content				40	40	40	
Expansion tank capacity				12	12	12	
Sound power		Nominal		41	41	41	
Sound pressure @1m		Nominal		26	26	26	
Size - Outdoor unit				6.1	7.1	8.1	
Power supply		Voltage/Frequency/Phases		V/Hz/n°			
Sound power		Minimum / Nominal		54 / 63	54 / 64	54 / 66	
Sound pressure @1m		Minimum / Nominal		41 / 50	41 / 51	41 / 53	
Operating range							
Water supply temperature	Heating / DHW	Full electric	Minimum / Maximum	°C			
		Hybrid	Minimum / Maximum	°C			
	Cooling	-	Minimum / Maximum	°C			
Operating range (Outdoor air)	Heating	-	Minimum / Maximum	°C			
	DHW	-	Minimum / Maximum	°C			
	Cooling	-	Minimum / Maximum	°C			

Data according to EN 14511:2022 and EN 14825:2022
 The Product complies with the European ErP Directive (EU Regulations 811/2013 - 813/2013 - 2016/2281). Energy classes with Control4 NRG system control

(1) Data according to EN 16147: amount of water at 40 °C with the same enthalpy content as the water coming out of the Boiler at a temperature higher than 40 °C

Dimensions and connections

Size			2.1	3.1	4.1	5.1	6.1	7.1	8.1	
Dimensions	Indoor unit ACS190	AxCxB	mm	600x1.696x612	600x1.696x612	600x1.696x612	600x1.696x612	-	-	-
	Indoor unit ACS250	AxCxB	mm	600x2.010x6112	600x2.010x6112	600x2.010x6112	600x2.010x6112	600x2.010x6112	600x2.010x6112	600x2.010x6112
	Outdoor unit	AxCxB	mm	920x712x400	920x712x400	1.042x866x444	1.042x866x444	1.042x866x444	1.042x866x444	1.042x866x444
Operating weight	Indoor unit ACS190		kg	417	417	417	417	-	-	-
	Indoor unit ACS250		kg	422	422	422	422	425	425	425
	Outdoor unit		kg	58	58	77	77	112	112	112
Max / min equivalent length	L	m	30 / 2	30 / 2	30 / 2	30 / 2	30 / 2	30 / 2	30 / 2	
Max difference in level ODU / IDU	H	m	25	25	25	25	25	25	25	
Refrigerant precharge		type / GWP		R-32 / 675	R-32 / 675	R-32 / 675	R-32 / 675	R-32 / 675	R-32 / 675	
		kg		1,50	1,50	1,65	1,65	1,84	1,84	1,84
		CO ² tons		1,05	1,05	1,10	1,10	1,24	1,24	1,24
Equivalent pipe length with pre-charging only		m		15	15	15	15	15	15	
External diameters	Refrigerant piping	Liquid	inch	1/4"	1/4"	3/8"	3/8"	3/8"	3/8"	3/8"
		Gas	inch	5/8"	5/8"	5/8"	5/8"	5/8"	5/8"	5/8"
	Indoor unit	Water (System)	inch	1"	1"	1"	1"	1"	1"	1"
		Water (DHW)	inch	1/2"	1/2"	1/2"	1/2"	1/2"	1/2"	1/2"

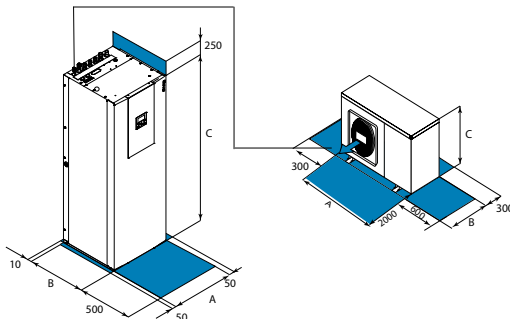

For trouble-free operation of the unit it is essential to maintain the safety distances indicated by the blue areas.

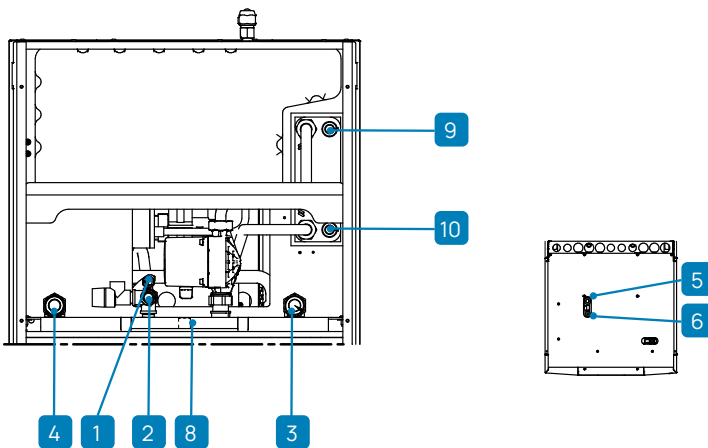

- 1 Domestic hot water outlet M 1/2"
- 2 Water supply system F 1/2"
- 3 Return from user side system M 1"
- 4 Supply to user system M 1"
- 5 Suction connection, 1/8" SAE
- 6 Liquid line connection, 3/8" SAE
- 7 Electrical line inlet
- 8 DHW circulation circuit inlet M 3/4"
- 9 Return from solar system M 3/4"
- 10 Supply to solar system M 3/4"
- 11 Unit control keypad

Check in the manual if the indoor unit requires a minimum installation surface

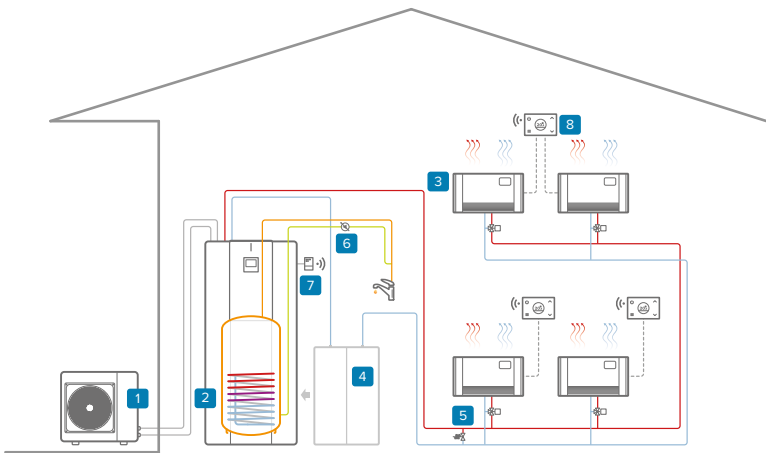

Full electric single-zone system:
Heating / Cooling / DHW

- 1 Outdoor unit
- 2 Indoor unit
- 3 heating/cooling zone
- 4 System inertial storage (optional)
- 5 Bypass*
- 6 DHW recirculation pump*
- 7 SwitchConnect Wi-Fi receiver (optional)
- 8 HID-TConnect2 Wi-Fi chronothermostat (optional)

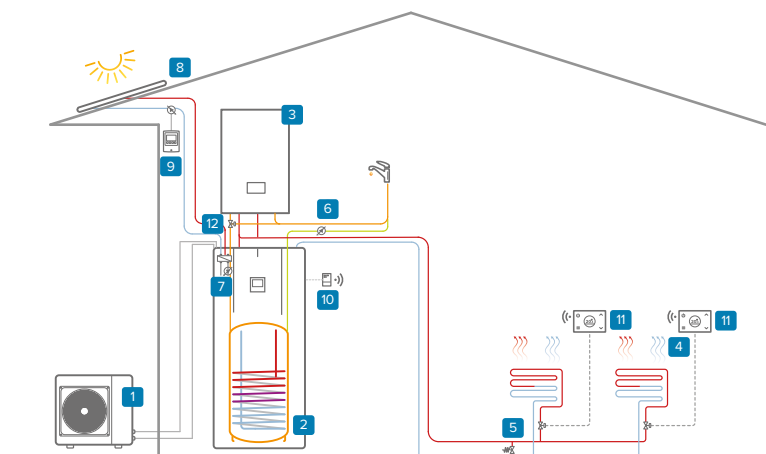

Hybrid single-area system with thermal solar:
Heating / Cooling / DHW

- 1 Outdoor unit
- 2 Indoor unit
- 3 instantaneous boiler (Hybrid version)
- 4 heating/cooling zone
- 5 Bypass*
- 6 DHW circulation pump (optional)
- 7 Solar connection kit (optional)
- 8 ELFOSun3 thermal solar (optional)
- 9 solar circulation kit (optional)
- 10 SwitchConnect Wi-Fi receiver (optional)
- 11 HID-TConnect2 Wi-Fi chronothermostat (optional)
- 12 Thermostated diverter valve for DHW (optional)

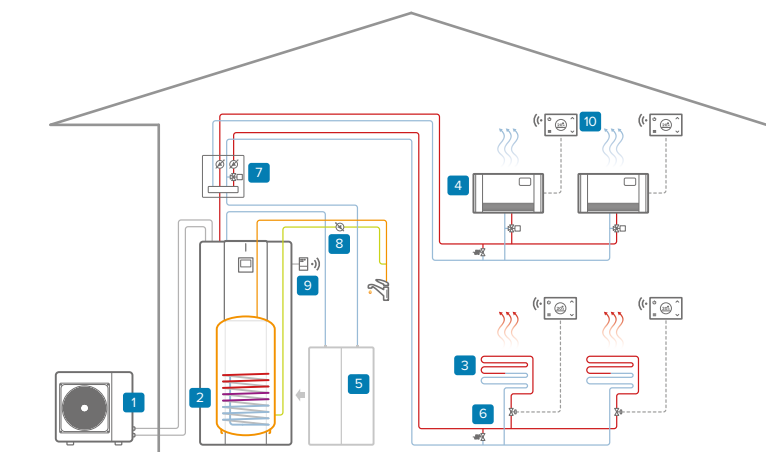

Full electric two-zone system:
Heating / Cooling / DHW

- 1 Outdoor unit
- 2 Indoor unit
- 3 Heating area
- 4 Cooling area
- 5 System inertial storage (optional)
- 6 Bypass*
- 7 Kit for managing 2 areas (optional)
- 8 DHW recirculation pump*
- 9 SwitchConnect Wi-Fi receiver (optional)
- 10 HID-TConnect2 Wi-Fi chronothermostat (optional)

The diagrams are for illustrative purposes only, showing possible combinations of system elements.

*from external supply

SPHERA EVO 2.0 BOX

Air-to-water Refrigerant-split heat pump with DHW tank for heating, cooling and domestic hot water production

Capacity from 4 to 16 kW



HEAT PUMPS

Energy saving



Solar integration (DHW tank - optional)



Cascade



Smart Grid ready



€-Switch

Comfort



Hot Cold



DHW



Silent

Reliability



Backup heater (optional)



Products Quality Casa Clima



025

Health



Renewable Energy (Full electric version)

Management and connectivity



Input ON/OFF



Port Modbus



Control via App



management CONTROL4 NRG



User interface / thermostat



Clivet Eye monitoring

Convenience



Weekley Timer



Instant DHW (Hybrid Version)



Contemporaneity (Hybrid Version)



- ✓ It does not need to be coupled to a boiler if DHW is produced by the boiler (Hybrid version)
- ✓ Energy efficiency at the highest level
- ✓ Designed not to disturb, operating very quietly
- ✓ Can be combined with DHW tanks of a volume suitable for the application in which it is to be installed
- ✓ Up to 6 units can be connected in cascade, for demands up to 100 kW

- 1 Inverter DC fan
- 2 Inverter DC twin-rotary compressor
- 3 Air-gas finned exchanger (blue fin treatment)
- 4 Gas/water plate exchanger
- 5 Inverter DC high efficiency pump
- 6 12-litre system expansion tank
- 7 3-way valve
- 8 Magnetic dirt separator filter
- 9 15-litre inertial tank

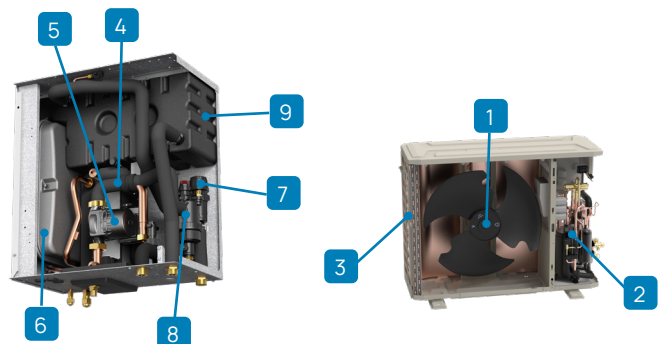

Ideal with AQUA F

SPHERA EVO BOX 2.0 is an excellent alternative for installations where it is not possible to install the tower or uncased version.

Combined with AQUA F, the heat pump for domestic hot water production, SPHERA EVO Box 2.0 offers the advantage of a system that provides simultaneous heating or cooling and domestic hot water production.



Configurations

OUTDOOR UNIT power supply (size 6.1+8.1):

220M	Power supply 230/1/20 (standard)
400TN	Power supply 400/3/50+N















PUMP:

-	Standard pump (standard)
1PUM	Pump with larger available head

BACK-UP ELECTRIC HEATER (integrated in the unit):

-	No heater (standard)
EH024	2/4 kW back-up heater
EH6	6 kW back-up heater
EH9	9 kW back-up heater

Accessories

	ACS200X	200 liter DHW tank		T1BX	10m water temperature probe
	ACS300X	300 liter DHW tank		T1B30X	30m water temperature probe
	ACS500X	500 liter DHW tank		VDACSX	Thermostated diverter valve for DHW
	SCS08X	Solar coil for ACS200X/ACS300X DHW tank		DTX	Drain pan with antifreeze electrical heater
	SCS12X	Solar coil for ACS500X DHW tank		APAVX	Kit of antivibration mounts for floor installation
	KCSX	Kit for secondary circuit (1 liter circuit breaker + circulation pump)		ASTFX	Antivibration mounts kit for installation on the brackets for wall installation or drain pan
	KIRE2HLX	Two-zone distribution kit: direct + mixed		KSIPX	Kit with wall fixing brackets
	KIRE2HX	Double zone distribution unit: direct + direct		KISX	Kit di installazione semplificata con raccordi per SPHERA EVO 2.0 Box Hybrid
	ACI40X	40 liter system inertial storage tank		HTC2WX	White HID-TConnect2 chronothermostat for temperature control
	DI50-2X	50 liter hydraulic separator		SWCX	Receiver / IoT switch SwitchConnect

Technical data

Size - Set				2.1	3.1	4.1	5.1	6.1	7.1	8.1		
Heating	Capacity	Water 35/30 °C	Nominal / Maximum	kW	4,32 / 6,26	6,18 / 7,41	8,30 / 9,11	10,1 / 10,3	12,1 / 14,6	14,5 / 15,5	16,0 / 16,8	
	COP	Outdoor air 7 °C	Nominal	-	5,42	5,21	5,31	5,01	5,00	4,70	4,55	
	Capacity	Water 35/30 °C	Nominal / Maximum	kW	4,17 / 6,25	6,05 / 6,97	7,33 / 8,35	8,20 / 9,30	10,5 / 13,9	12,2 / 14,1	13,4 / 14,3	
	COP	Outdoor air -7 °C	Nominal	-	3,16	3,00	3,23	3,07	3,13	2,82	2,74	
	Capacity	Water 45/40 °C	Nominal / Maximum	kW	4,16 / 5,96	6,03 / 7,13	8,22 / 8,98	10,0 / 10,3	12,3 / 14,5	14,0 / 15,7	16,0 / 16,6	
	COP	Outdoor air 7 °C	Nominal	-	3,93	3,83	3,95	3,86	3,80	3,65	3,60	
Cooling	Capacity	Water 18/23 °C	Nominal / Maximum	kW	4,55 / 6,88	6,44 / 7,65	8,10 / 11,1	10,0 / 12,0	12,1 / 15,0	13,8 / 15,3	14,8 / 16,4	
	EER	Outdoor air 35 °C	Nominal	-	6,08	5,24	5,12	4,77	4,02	3,70	3,65	
	Capacity	Water 7/12 °C	Nominal / Maximum	kW	4,26 / 6,14	6,25 / 6,39	7,46 / 7,94	8,67 / 9,10	11,8 / 11,8	12,9 / 12,9	14,2 / 14,2	
	EER	Outdoor air 35 °C	Nominal	-	3,50	3,09	3,33	3,09	2,75	2,55	2,45	
Electrical power for meter sizing				kW	2,20	2,60	3,30	3,60	5,40	5,70	6,10	
Seasonal efficiency Medium climate	Energy class			-	A++	A++	A++	A++	A++	A++	A++	
	Heating Water 55 °C	Annual energy consumption			-	2.519	3.255	3.824	4.749	6.774	7.277	7.825
		SCOP			-	3,35	3,57	3,72	3,73	3,57	3,57	3,52
		ns (seasonal output)			%	131	140	146	146	140	140	138
	Energy class			-	A+++	A+++	A+++	A+++	A+++	A+++	A+++	
	Heating Water 35 °C	Annual energy consumption			-	2.161	2.502	3.141	3.747	4.994	5.868	6.602
		SCOP			-	5,13	5,15	5,32	5,27	5,00	4,91	4,89
		ns (seasonal output)			%	202	203	210	208	196	193	193
	Size - Indoor unit				A	A	A	A	B	B	B	
	Power supply	Voltage/Frequency/Phases		V/Hz/n°	230/50/1							
Water flow-rate	Water 35/30 °C	Nominal	l/s	0,21	0,30	0,41	0,49	0,57	0,67	0,75		
Pump available pressure	Outdoor air 7 °C	Nominal	kPa	31,2	36,5	33,1	31,0	25,7	31,7	22,6		
Minimum system water content				l	40	40	40	40	40	40		
Expansion tank capacity				l	12	12	12	12	12	12		
Sound power			Nominal	dB(A)	41	41	41	41	41	41	41	
Sound pressure @1m			Nominal	dB(A)	26	26	26	26	26	26	26	
Size - Outdoor unit				2.1	3.1	4.1	5.1	6.1	7.1	8.1		
Power supply	Voltage/Frequency/Phases		V/Hz/n°	230/50/1								
Sound power			Minimum / Nominal	dB(A)	50 / 55	51 / 57	52 / 58	52 / 60	54 / 63	54 / 64	54 / 66	
Sound pressure @1m			Minimum / Nominal	dB(A)	37 / 42	38 / 44	39 / 45	39 / 47	41 / 50	41 / 51	41 / 53	
Operating range												
Water supply temperature	Heating / DHW	Full electric	Minimum / Maximum	°C	25 / 65							
		Hybrid	Minimum / Maximum	°C	25 / 75							
	Cooling	-	Minimum / Maximum	°C	5 / 25							
Operating range (Outdoor air)	Heating	-	Minimum / Maximum	°C	-25 / 35							
	DHW	-	Minimum / Maximum	°C	-25 / 43							
	Cooling	-	Minimum / Maximum	°C	-5 / 43							

Data according to EN 14511:2022 and EN 14825:2022

The Product complies with the European ErP Directive (EU Regulations 811/2013 - 813/2013 - 2016/2281). Energy classes with energy assistant for Clivet Smart Home

(1) Data according to EN 16147: amount of water at 40 °C with the same enthalpy content as the water coming out of the Boiler at a temperature higher than 40 °C

HEAT PUMPS

Size - Set (400TN version)				6.1	7.1	8.1		
Heating	Capacity	Water 35/30 °C	Nominal / Maximum	kW	12,1 / 14,6	14,5 / 15,5	16,0 / 16,8	
	COP	Outdoor air 7 °C	Nominal	-	5,00	4,70	4,55	
	Capacity	Water 35/30 °C	Nominal / Maximum	kW	10,5 / 13,9	12,2 / 14,1	13,4 / 14,3	
	COP	Outdoor air -7 °C	Nominal	-	3,13	2,82	2,74	
	Capacity	Water 45/40 °C	Nominal / Maximum	kW	12,3 / 14,5	14,0 / 15,7	16,0 / 16,6	
	COP	Outdoor air 7 °C	Nominal	-	3,80	3,65	3,60	
Cooling	Capacity	Water 18/23 °C	Nominal / Maximum	kW	12,1 / 15,0	13,8 / 15,3	14,8 / 16,4	
	EER	Outdoor air 35 °C	Nominal	-	4,02	3,70	3,65	
	Capacity	Water 7/12 °C	Nominal / Maximum	kW	11,8 / 11,8	12,9 / 12,9	14,2 / 14,2	
	EER	Outdoor air 35 °C	Nominal	-	2,75	2,55	2,45	
Electrical power for meter sizing				kW	5,40	5,70	6,10	
Seasonal efficiency	Heating	Energy class	-	A++	A++	A++		
Medium climate	Water 55 °C	Annual energy consumption	-	6.774	7.277	7.825		
		SCOP	-	3,57	3,57	3,52		
		ns (seasonal output)	%	140	140	138		
	Water 35 °C	Energy class	-	A+++	A+++	A+++		
		Annual energy consumption	-	4.994	5.868	6.602		
		SCOP	-	5,00	4,91	4,89		
ns (seasonal output)				%	196	193	193	
Size - Indoor unit					B	B	B	
Power supply	Voltage/Frequency/Phases			V/Hz/n°	230/50/1			
Water flow-rate	Water 35/30 °C	Nominal		l/s	0,57	0,67	0,75	
Pump available pressure	Outdoor air 7 °C	Nominal		kPa	25,7	31,7	22,6	
Minimum system water content				l	40	40	40	
Expansion tank capacity				l	12	12	12	
Sound power				Nominal	dB(A)	41	41	41
Sound pressure @1m				Nominal	dB(A)	26	26	26
Size - Outdoor unit					6.1	7.1	8.1	
Power supply	Voltage/Frequency/Phases			V/Hz/n°	400/50/3+N			
Sound power				Minimum / Nominal	dB(A)	54 / 63	54 / 64	54 / 66
Sound pressure @1m				Minimum / Nominal	dB(A)	41 / 50	41 / 51	41 / 53
Operating range								
Water supply temperature	Heating / DHW	Full electric	Minimum / Maximum	°C	25 / 65	25 / 65	25 / 65	
		Hybrid	Minimum / Maximum	°C	25 / 75	25 / 75	25 / 75	
	Cooling	-	Minimum / Maximum	°C	5 / 25	5 / 25	5 / 25	
Operating range (Outdoor air)	Heating	-	Minimum / Maximum	°C	-25 / 35	-25 / 35	-25 / 35	
	DHW	-	Minimum / Maximum	°C	-25 / 43	-25 / 43	-25 / 43	
	Cooling	-	Minimum / Maximum	°C	-5 / 43	-5 / 43	-5 / 43	

Data according to EN 14511:2022 and EN 14825:2022
 The Product complies with the European ErP Directive (EU Regulations 811/2013 - 813/2013 - 2016/2281). Energy classes with Control4 NRG system control

(1) Data according to EN 16147: amount of water at 40 °C with the same enthalpy content as the water coming out of the Boiler at a temperature higher than 40 °C

Dimensions and connections

Size				2.1	3.1	4.1	5.1	6.1	7.1	8.1
Dimensions	Indoor unit	AxCxB	mm	547x604x389	547x604x389	547x604x389	547x604x389	547x604x389	547x604x389	547x604x389
	Outdoor unit	AxCxB	mm	920x712x400	920x712x400	1.042x866x444	1.042x866x444	1.042x866x444	1.042x866x444	1.042x866x444
Weight	Indoor unit		kg	60	60	60	60	62	62	62
	Outdoor unit		kg	58	58	77	77	112	112	112
Max / min equivalent length	L		m	30 / 2	30 / 2	30 / 2	30 / 2	30 / 2	30 / 2	30 / 2
Max difference in level ODU / IDU	H		m	25	25	25	25	25	25	25
Refrigerant precharge		tipo/GWP		R-32 / 675	R-32 / 675	R-32 / 675	R-32 / 675	R-32 / 675	R-32 / 675	R-32 / 675
			kg	1,50	1,50	1,65	1,65	1,84	1,84	1,84
			CO2 tons	1,05	1,05	1,10	1,10	1,24	1,24	1,24
Equivalent pipe length with pre-charging only			m	15	15	15	15	15	15	15
External diameters	Refrigerant piping	Liquid	inch	1/4"	1/4"	3/8"	3/8"	3/8"	3/8"	3/8"
		Gas	inch	5/8"	5/8"	5/8"	5/8"	5/8"	5/8"	5/8"
	Indoor unit	Water (System)	inch	1"	1"	1"	1"	1"	1"	1"
		Water (DHW)	inch	1"	1"	1"	1"	1"	1"	1"

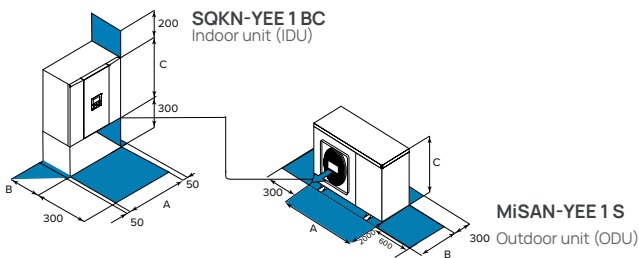

For trouble-free operation of the unit it is essential to maintain the safety distances indicated by the blue areas.

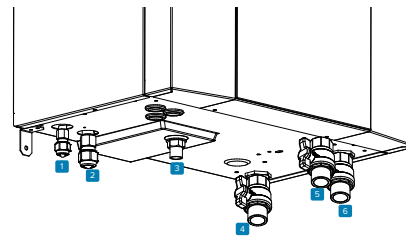

- 1 Refrigerant - liquid pipe
- 2 Refrigerant - gas pipe
- 3 Domestic hot water - return from exchanger
- 4 DHW exchanger return Ø 1"
- 5 Supply to system Ø 1"
- 6 Return from system Ø 1"

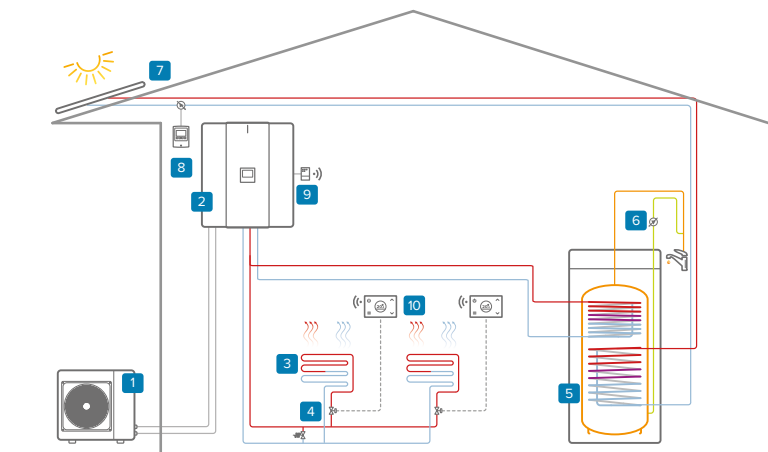

Full electric single-area system with thermal solar:
Heating / Cooling / DHW

- 1 Outdoor unit
- 2 Indoor unit
- 3 heating/cooling zone
- 4 Bypass*
- 5 DHW boiler with solar coil (optional)
DHW recirculation pump*
- 6 ELFOSun3 thermal solar (optional)
solar circulation kit (optional)
- 7
- 8 SwitchConnect Wi-Fi receiver (optional)
- 9 HID-TConnect2 Wi-Fi chronothermostat (optional)
- 10

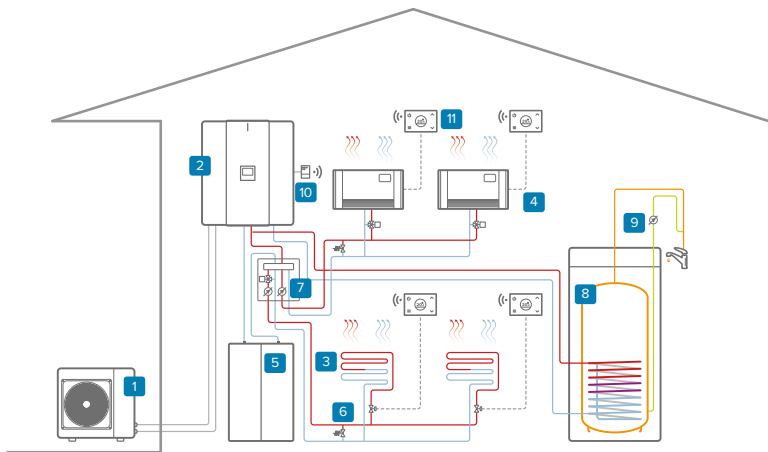

Full electric two-zone system:
Heating / Cooling / DHW

- 1 Outdoor unit
- 2 Indoor unit
- 3 Mixed heating/cooling zone
- 4 Direct heating/cooling zone
- 5 System inertial storage (optional)
- 6 Bypass*
- 7 Kit for managing 2 areas (optional)
- 8 DHW tank (optional)
- 9 DHW recirculation pump*
- 10 SwitchConnect Wi-Fi receiver (optional)
- 11 HID-TConnect2 Wi-Fi chronothermostat (optional)

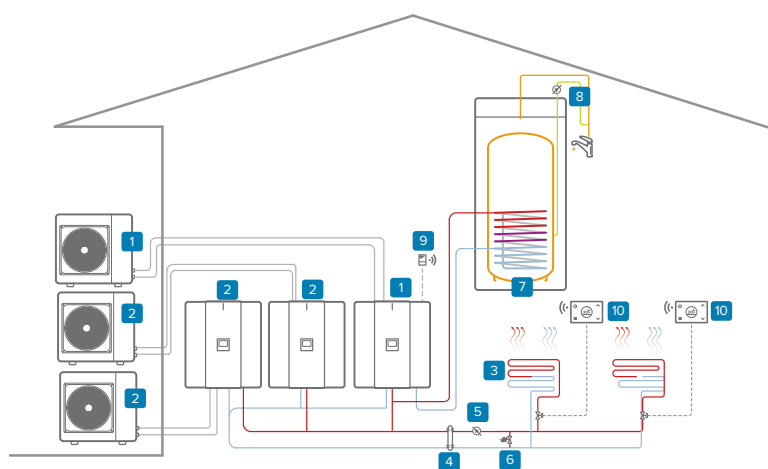

Full electric single-zone system in cascade:
Heating / Cooling / DHW

- 1 Outdoor unit + indoor unit (Master)
- 2 Outdoor unit + indoor unit (Slave)
- 3 heating/cooling zone
- 4 Hydraulic separator (optional)
- 5 Secondary circuit pump
- 6 Bypass*
- 7 DHW tank (optional)
- 8 DHW recirculation pump*
- 9 SwitchConnect Wi-Fi receiver (optional)
- 10 HID-TConnect2 Wi-Fi chronothermostat (optional)

The diagrams are for illustrative purposes only, showing possible combinations of system elements.

*from external supply

SPHERA EVO 2.0 INVISIBLE

Built-in air-to-water refrigerant-split heat pump
for heating, cooling and domestic hot water production

Capacity from 4 a 10 kW



HEAT PUMPS

Energy saving



Solar
integration (DHW
tank - optional)



Smart Grid
ready



€-Switch

Comfort



Hot
Cold



DHW



Silent

Reliability



Backup heater
(optional)



Products
Quality
Casa Clima



025

Health



Renewable Energy
(Full electric
version)

Management and connectivity



Input ON/
OFF



Port
Modbus



Control
via App



management
CONTROL4 NRG



User interface /
thermostat



Clivet Eye
monitoring

Convenience



Weekly Timer



Integrated
DHW tank



Instant DHW
(Hybrid Version)



Contemporaneity
(Hybrid Version)



ErP



- ✓ Space-saving: completely outdoor installation with uncased wall-mounted unit only 36cm deep
- ✓ It adapts to every need: solar kit / inertial tank kit / additional tank / integrated combinable boiler
- ✓ Components and uncased cabinet with telescopic frame can be supplied separately
- ✓ New additional aesthetic practical cabinet for system accessories in full view for outdoor installation.
- ✓ Advanced connectivity: management via dedicated Smart Home App or via Modbus port with CONTROL4 NRG included as standard

Optimize the space

SPHERA EVO 2.0 INVISIBLE is the ideal choice for all homes that do not have a technical room and which need to make the unit invisible by embedding it in the wall.

The cabinet has an adjustable telescopic frame and can be painted to make the unit disappear completely.



Full electric Version

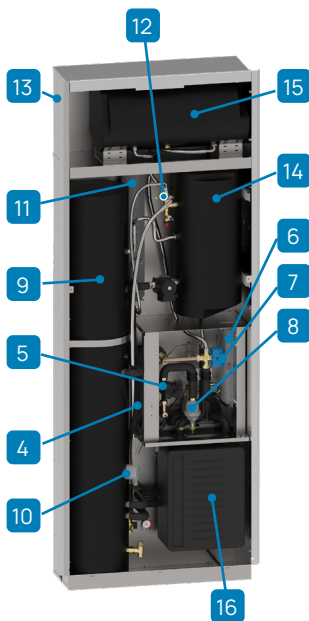

Hybrid Version with Gas Boiler FE 24.4

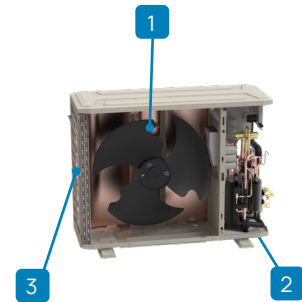
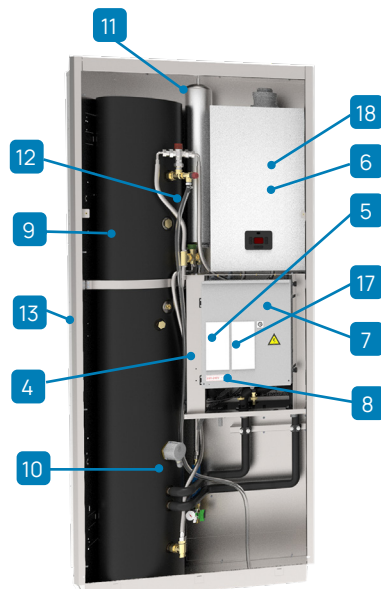

- 1 Inverter DC fan
- 2 Inverter DC twin-rotary compressor
- 3 Air-gas finned exchanger (blue fin treatment)
- 4 Gas/water plate exchanger
- 5 Inverter DC high efficiency pump
- 6 12-litre system expansion tank
- 7 3-way valve
- 8 Magnetic dirt separator filter
- 9 150 LDHW tank with coil
- 10 2 kW DHW safety heater
- 11 8 LDHW expansion tank

- 12 Anti-scalding valve
- 13 Cabinet with adjustable telescopic frame
- 14 Additional 50 LDHW storage tank (optional)
- 15 System buffer tank kit (optional)
- 16 Kit for managing 2 zones (optional)
- 17 Dedicated hydraulic connection for FE boiler (Hybrid version with FE Gas Boiler)
- 18 Boiler (optional)
- 19 15-litre inertial tank

Configurations

VERSION:

IC	Full electric (standard)
IH	Hybrid

PUMP:

-	Standard pump (standard)
1PUM	Pump with larger available head

BACK-UP ELECTRIC HEATER (integrated in the unit):

-	No heater (standard)
EH024	2/4 kW back-up heater
EH6	6 kW back-up heater
EH9	9 kW back-up heater

Mandatory accessories



ADIX Main built-in cabinet

ACS150X 150 liter DHW tank



KCIACSX DHW storage connection kit

Accessories



AENVX Additional aesthetic practical cabinet for system accessories in full view



DPX Template for connecting the additional aesthetic practical cabinet for system accessories in full view



ADIAX In-wall cabinet for 150 liter DHW tank

ACSA150X Additional 150 liter DHW tank



KCI150X Pipe connection kit for additional DHW tank for SPHERA Invisible



ACSA50X Additional 50 liter DHW tank



SHWTX 150 liter DHW tank with solar coil



KCVEX Circulation group, control unit and expansion vessel



KPRSX DHW recirculation pump kit (for installation inside the unit)



KCSIX Kit for secondary circuit (1 liter circuit breaker + circulation pump)



KIR2HLX Two-zone distribution kit: direct + mixed



KIR2HX Two-zone distribution kit: direct + mixed (for installation inside the unit)



AC50X 50 liter system inertial storage tank (for installation inside the unit)



KAIAX Additional inertial tank connection kit



ACE50X 50 liter system inertial storage tank (for installation outside the unit)



ADI50X In-wall cabinet for inertial storage tank or solar kit



KCIBOIX IH hybrid version connection kit



KSDFX Splitter for suction and flue gas discharge (d. 80/80 mm)



CCOAX 90° coaxial curve for suction and flue gas discharge, 360° adjustable (d. 60/100 mm)



DTX Drain pan with antifreeze electrical heater



APAVX Kit of antivibration mounts for floor installation



ASTFX Antivibration mounts kit for installation on the brackets for wall installation or drain pan



KSIPX Kit with wall fixing brackets



HTC2WX White HID-TConnect² chronothermostat for temperature control



SWCX Receiver / IoT switch SwitchConnect

A115X 15 litre inertial storage tank for indoor installation

Technical data

Size					2.1	3.1	4.1	5.1
Heating	Capacity	Water 35/30 °C	Nominal / Maximum	kW	4,32 / 6,26	6,18 / 7,41	8,30 / 9,11	10,1 / 10,3
	COP	Outdoor air 7 °C	Nominal	-	5,42	5,21	5,31	5,01
	Capacity	Water 35/30 °C	Nominal / Maximum	kW	4,17 / 6,25	6,05 / 6,97	7,33 / 8,35	8,20 / 9,30
	COP	Outdoor air -7 °C	Nominal	-	3,16	3,00	3,23	3,07
Cooling	Capacity	Water 45/40 °C	Nominal / Maximum	kW	4,16 / 5,96	6,03 / 7,13	8,22 / 8,98	10,0 / 10,3
	COP	Outdoor air 7 °C	Nominal	-	3,93	3,83	3,95	3,86
	Capacity	Water 18/23 °C	Nominal / Maximum	kW	4,55 / 6,88	6,44 / 7,65	8,10 / 11,1	10,0 / 12,0
	EER	Outdoor air 35 °C	Nominal	-	6,08	5,24	5,12	4,77
DHW	Capacity	Water 7/12 °C	Nominal / Maximum	kW	4,26 / 6,14	6,25 / 6,39	7,46 / 7,94	9,10 / 9,10
	EER	Outdoor air 35 °C	Nominal	-	3,50	3,09	3,33	3,09
Electrical power for meter sizing	Net tank capacity			l			143	
	Water mixed at 40 °C (V40)1			l			188	
Seasonal efficiency Medium climate	Heating	Water 55 °C	Annual energy consumption	-	2.542	3.283	3.824	4.749
	Heating	Water 55 °C	SCOP	-	3,32	3,54	3,72	3,73
			ns (seasonal output)	%	130	138	146	146
	DHW	Water 35 °C	Energy class	-	A+++	A+++	A+++	A+++
Annual energy consumption			-	2.161	2.502	3.141	3.747	
DHW	Water 35 °C	SCOP	-	5,13	5,15	5,32	5,27	
		ns (seasonal output)	%	202	203	210	208	
Size - Indoor unit	DHW	Withdrawal profile	Energy class	-	A+	A+	A+	A+
			Withdrawal profile	-	L	L	L	L
Size - Indoor unit					A			
Power supply	Voltage/Frequency/Phases			V/Hz/n°	230/50/1			
Water flow-rate	Water 35/30 °C	Nominal	l/s	0,21	0,30	0,41	0,49	
Pump available pressure	Outdoor air 7 °C	Nominal	kPa	31,2	36,5	33,1	31,0	
Minimum system water content				l	40			
Expansion tank capacity				l	12			
Sound power	Nominal			dB(A)	41			
Sound pressure @1m	Nominal			dB(A)	26			
Boiler - Hybrid version - SQKN-YEE 1 IH					GAS BOILER FE 24.4 / FE 33.4			
Boiler	Nominal Heating capacity ((LHV)	Water 80/60 °C	Nominal	kW	24,0 / 34,0			
	Efficiency	Nominal			%			
Power supply	Voltage/Frequency/Phases			V/Hz/n°	230/50/1			
Power input	Water content			W	82 / 99			
Sound power	Nominal			dB(A)	49 / 52			
Size - Outdoor unit					2.1	3.1	4.1	5.1
Power supply	Voltage/Frequency/Phases			V/Hz/n°	230/50/1			
Sound power	Minimum / Nominal			dB(A)	50 / 55	51 / 57	52 / 58	52 / 60
Sound pressure @1m	Minimum / Nominal			dB(A)	37 / 42	38 / 44	39 / 45	39 / 47
Operating range								
Water supply temperature	Heating / DHW	Full electric	Minimum / Maximum	°C	25 / 65			
		Hybrid	Minimum / Maximum	°C	25 / 75			
Operating range (Outdoor air)	Cooling	-	Minimum / Maximum	°C	5 / 25			
		Heating	-	Minimum / Maximum	°C	-25 / 35		
Operating range (Outdoor air)	DHW	-	Minimum / Maximum	°C	-25 / 43			
		Cooling	-	Minimum / Maximum	°C	-5 / 43		

Data according to EN 14511:2022 and EN 14825:2022
The Product complies with the European ErP Directive (EU Regulations 811/2013 - 813/2013 - 2016/2281). Energy classes with CONTROL4 NRG system control

(1) Data according to EN 16147: amount of water at 40 °C with the same enthalpy content as the water coming out of the Boiler at a temperature higher than 40 °C

Dimensions and connections

Size				2.1	3.1	4.1	5.1
Dimensions	Indoor unit	AxCxB	mm		950x2.200x360		
	Outdoor unit	AxCxB	mm	920x712x400		1.042x866x444	
Operating weight	Indoor unit		kg		317		
	Boiler FE 24.4 / FE 33.4		kg		31 / 34		
	Outdoor unit		kg	58		77	
Max / min equivalent length	L		m		30 / 2		
Max difference in level ODU / IDU	H		m		25		
			type / GWP		R-32 / 675		
Refrigerant precharge			kg	1.50		1.65	
			CO ² tons	1.05		1.10	
Equivalent pipe length with pre-charging only			m		15		
Refrigerant piping	Liquid		inch	1/4"		3/8"	
	Gas		inch		5/8"		
External diameters	Indoor unit	Water (System)	inch	1"			
		Water (DHW)	inch	3/4"			
	Boiler Hybrid Version	Intake air	mm	80			
		Exhaust gas	mm	80			

Check in the manual if the indoor unit requires a minimum installation surface

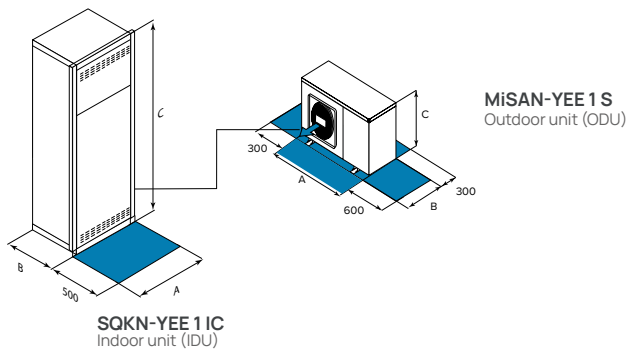

For trouble-free operation of the unit it is essential to maintain the safety distances indicated by the blue areas.

HEAT PUMPS

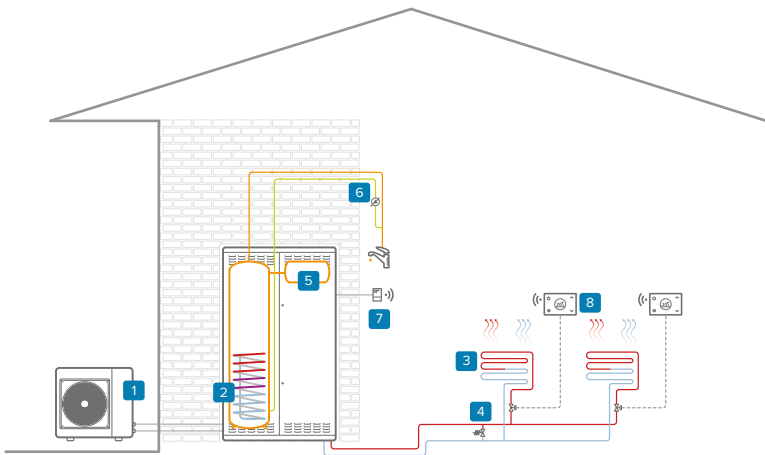

Full electric single-zone system:
Heating / Cooling / DHW

- 1 Outdoor unit
- 2 Indoor unit
- 3 heating/cooling zone
- 4 Bypass*
- 5 additional DHW tank (optional)
- 6 DHW recirculation pump*
- 7 SwitchConnect Wi-Fi receiver (optional)
- 8 HID-TConnect2 Wi-Fi chronothermostat (optional)

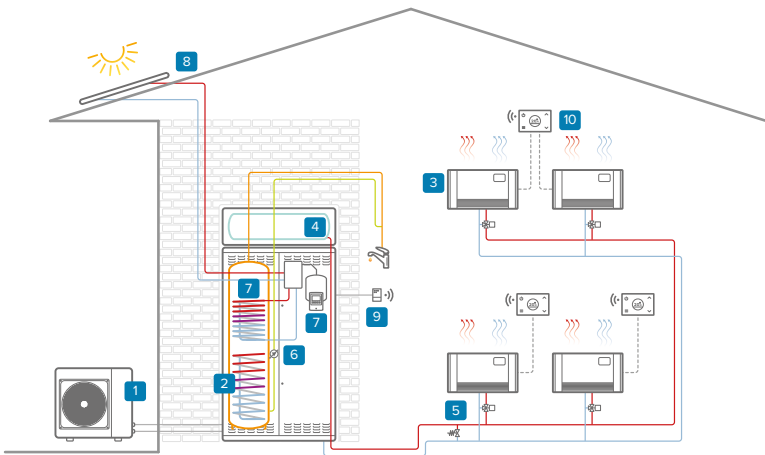

Full electric single-area system with thermal solar:
Heating / Cooling / DHW

- 1 Outdoor unit
- 2 Indoor unit
- 3 heating/cooling zone
- 4 System inertial storage (optional)
- 5 Bypass*
- 6 DHW circulation pump (optional)
- 7 Solar connection kit (optional)
- 8 ELFOSUN3 thermal solar collector (optional)
- 9 SwitchConnect Wi-Fi receiver (optional)
- 10 HID-TConnect2 Wi-Fi chronothermostat (optional)

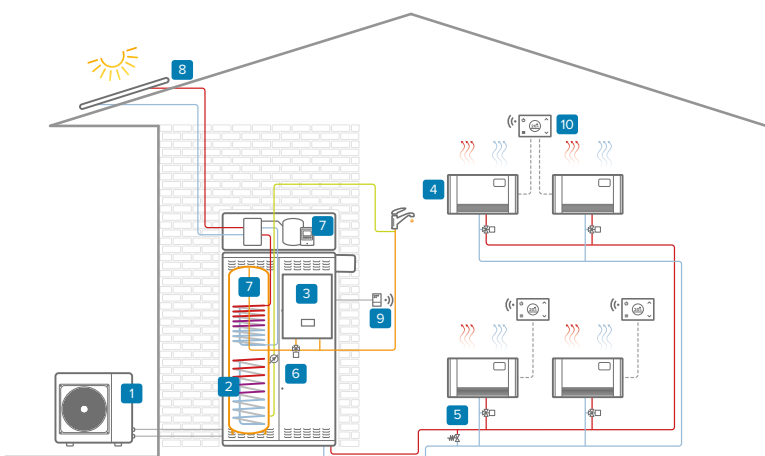

Hybrid single-area system with thermal solar:
Heating / Cooling / DHW

- 1 Outdoor unit
- 2 Indoor unit
- 3 Boiler with instantaneous DHW (Hybrid version)
- 4 heating/cooling zone
- 5 Bypass*
- 6 DHW circulation pump (optional)
- 7 Solar connection kit (optional)
- 8 ELFOSun3 thermal solar collector (optional)
- 9 SwitchConnect Wi-Fi receiver (optional)
- 10 HID-TConnect2 Wi-Fi chronothermostat (optional)

The diagrams are for illustrative purposes only, showing possible combinations of system elements.

*from external supply

Technical insight

Depending on the version chosen, indoor and outdoor units may require a different type of power supply. See the table below for details:

		Indoor unit			
		standard	EH024	EH6	EH9
		230V/1/50Hz		400V/3/50Hz	
Outdoor unit	2.1	A	A	A	A
	3.1	A	A	A	A
	4.1	A	A	A	A
	5.1	A	A	A	A
	6.1	B	B	B	B
	7.1	B	B	B	B
	8.1	B	B	B	B
	6.1	B	B	B	B
	7.1	B	B	B	B
	8.1	B	B	B	B

HEAT PUMPS

SPHERA EVO 2.0 EASYHYBRID BOX

Wall-mounted air-to-water Refrigerant-split hybrid heat pump for heating, cooling and domestic hot water production

Capacity from 4 to 16 kW



Energy saving



Solar integration (DHW tank - optional)



Cascade



€-Switch

Comfort



Hot Cold



DHW



Silent

Convenience



Weekley Timer



Instant DHW (Hybrid Version)



Contemporaneity

Management and connettivity



Input ON/OFF



Port Modbus



Control via App



management CONTROL4 NRG



Clivet Eye monitoring

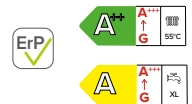

- ✓ Ideal for replacing old systems while keeping existing radiators
- ✓ Perfect for replacing a boiler: designed with similar overall dimensions
- ✓ 24 or 34 kW boiler to fulfil all requirements, with instant DHW production
- ✓ Simultaneous heating and cooling operation and DHW supply
- ✓ Connectivity and APP to keep the system under control

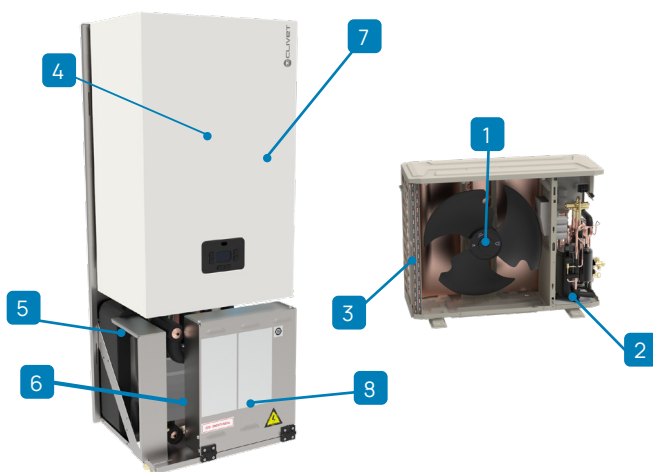

- 1 Inverter DC fan
- 2 Inverter DC twin-rotary compressor
- 3 Air-gas finned exchanger (blue fin treatment)
- 4 Instantaneous condensing boiler
- 5 Gas/water plate exchanger
- 6 Inverter DC high efficiency pump
- 7 8- or 10-litre system expansion tank
- 8 Electrical control panel

HEAT PUMPS

The €/Switch function

Sphera EVO 2.0 EASYHybrid Box has a function that can be selected directly from the interface, which makes it possible to calculate the resource (heat pump and/or boiler) that is able to fulfil the heat demand with the lowest economic cost in every operating condition. To use the €/Switch function, simply enter the cost per kWh of electricity and the cost per m³ of methane gas from the energy provider's supply contract, and define the main type of terminals in the building (radiant panel, fan coil, radiator).

Configurations



















POWER INPUT OUTDOOR UNIT (GR. 6.1+8.1):

220M	Power supply 230/1/20 (standard)
400TN	Power supply 400/3/50+N

INTEGRATED CONDENSING BOILER:

HYFE24	24 kW instantaneous boiler
HYFE34	34 kW instantaneous boiler

Accessories

	ACS200X	200 liter DHW tank		CCOAX	90° coaxial curve for suction and flue gas discharge, 360° adjustable (d. 60/100 mm)
	ACS300X	300 liter DHW tank			
	ACS500X	500 liter DHW tank		TCOAX	1 m coaxial pipe with terminal (d. 60/100 mm)
	SRICX	Additional PCB for 2-zone management		VDACSX	Thermostated diverter valve for DHW
	KCSX	Kit for secondary circuit (1 liter circuit breaker + circulation pump + management PCB)		3DHWX	3-way deviating valve for system/DHW 1" connections
	SCS08X	Solar coil for ACS200X/ACS300X DHW tank			
	SCS12X	Solar coil for ACS500X DHW tank		DTX	Drain pan with antifreeze electrical heater
	KIRE2HLX	Two-zone distribution kit management PCB: direct + mixed		APAVX	Kit of antivibration mounts for floor installation
	KIRE2HX	Two-zone distribution kit management PCB: direct + direct		ASTFX	Antivibration mounts kit for installation on the brackets for wall installation or drain pan
	DI50-2X	50 liter hydraulic separator		KSIPX	Kit with wall fixing brackets
	ACI40X	40 liter system inertial storage tank			
	KSDFX	Splitter for suction and flue gas discharge (d. 80/80 mm)		HTC2WX	White HID-TConnect ² chronothermostat for temperature control
	KCSAFX	Vertical coaxial fitting for smoke intake and discharge (d. 60/100 mm)		SWCX	Receiver / IoT switch SwitchConnect

Technical data

Size				2.1		3.1		4.1		5.1		6.1		7.1		8.1	
HYFE boiler				24	34	24	34	24	34	24	34	34	34	34	34		34
Heating Heat pump	Capacity	Water 35/30 °C	Nominal / Maximum	kW	4,32 / 6,26	6,18 / 7,41	8,30 / 9,11	10,1 / 10,3	12,1 / 14,6	14,5 / 15,5	16,0 / 16,8						
	COP	Outdoor air 7 °C	Nominal	-	5,42	5,21	5,31	5,01	5,00	4,70	4,55						
	Capacity	Water 35/30 °C	Nominal / Maximum	kW	4,17 / 6,25	6,05 / 6,97	7,33 / 8,35	8,20 / 9,30	10,5 / 13,9	12,2 / 14,1	13,4 / 14,3						
	COP	Outdoor air -7 °C	Nominal	-	3,16	3	3,23	3,07	3,13	2,82	2,74						
Heating Boiler	Capacity	Water 45/40 °C	Nominal / Maximum	kW	4,16 / 5,96	6,03 / 7,13	8,22 / 8,98	10,0 / 10,3	12,3 / 14,5	14,0 / 15,7	16,0 / 16,6						
	COP	Outdoor air 7 °C	Nominal	-	3,93	3,83	3,95	3,86	3,80	3,65	3,60						
	Nominal Heating capacity ((LHV)	Water 80/60 °C	Nominal	kW	24,0	34,0	24,0	34,0	24,0	34,0	34,0	34,0	34,0	34,0	34,0	34,0	34,0
	Efficiency		Nominal	%	97,8	97,7	97,8	97,7	97,8	97,7	97,8	97,7	97,7	97,7	97,7	97,7	
Cooling	Capacity	Water 18/23 °C	Nominal / Maximum	kW	4,55 / 6,88	6,44 / 7,65	8,10 / 11,1	10,0 / 12,0	12,1 / 15,0	13,8 / 15,3	14,8 / 16,4						
	EER	Outdoor air 35 °C	Nominal	-	6,08	5,24	5,12	4,77	4,02	3,70	3,65						
	Capacity	Water 7/12 °C	Nominal / Maximum	kW	4,26 / 6,14	6,25 / 6,39	7,46 / 7,94	9,10 / 9,10	11,8 / 11,8	12,9 / 12,9	14,2 / 14,2						
	EER	Outdoor air 35 °C	Nominal	-	3,50	3,09	3,33	3,09	2,75	2,55	2,45						
DHW Boiler	Capacity		Maximum	kW	24,0	34,0	24,0	34,0	24,0	34,0	34,0	34,0	34,0	34,0	34,0	34,0	
	Specific flow rate	Water with $\Delta T = 30$ °C in 10 minutes		l/min	13,5	16,0	13,5	16,0	13,5	16,0	16,0	16,0	16,0	16,0	16,0	16,0	
Electrical power for meter sizing				kW	2,20	2,60	3,30	3,60	5,40	5,70	6,10						
Energy class				-	A++	A++	A++	A++	A++	A++	A++	A++	A++	A++	A++	A++	A++
Seasonal efficiency Average climate	Heating Water 55 °C	Annual energy consumption	kWh/year	2,542	3,283	3,824	4,749	6,793	7,380	7,915							
		SCOP	-	3,32	3,54	3,72	3,73	3,56	3,52	3,48							
	DHW Boiler	ns (seasonal output)	%	130	138	146	146	139	138	136							
		Energy class	-	A+++	A+++	A+++	A+++	A+++	A+++	A+++	A+++	A+++	A+++	A+++	A+++	A+++	
DHW Boiler	Heating Water 35 °C	Annual energy consumption	kWh/year	2,161	2,502	3,141	3,747	4,994	5,868	6,602							
		SCOP	-	5,13	5,15	5,32	5,27	5,00	4,91	4,89							
	ns (seasonal output)	%	202	203	210	208	196	193	193								
Energy class				-	A	A	A	A	A	A	A	A	A	A	A	A	
Withdrawal profile				-	XL	XXL	XL	XXL	XL	XXL	XL	XXL	XXL	XXL	XXL	XXL	
Size - Indoor unit																	
Power supply				Voltage/Frequency/Phases	V/Hz/n°	230/50/1											
Water flow-rate				Water 35/30 °C	Nominal	l/s	0,21	0,30	0,41	0,49	0,57	0,67	0,75				
Pump available pressure				Outdoor air 7 °C	Nominal	kPa	31,2	36,5	33,1	31,0	25,7	31,7	22,6				
Minimum system water content						l	40										
Expansion tank capacity						l	8 (HYFE24) / 10 (HYFE34)										
Sound power				Operation:	Nominal	dB(A)	41 / 46	41 / 46	41 / 46	41 / 46	41 / 46	41 / 46	41 / 46	41 / 46	41 / 46		
Sound pressure @1m				heat pump only / heat pump + boiler	Nominal	dB(A)	28 / 33	28 / 33	28 / 33	28 / 33	28 / 33	28 / 33	28 / 33	28 / 33	28 / 33		
HYFE boiler																	
Power supply				Voltage/Frequency/Phases	V/Hz/n°	230/50/1											
Power input				Water content	W	82 / 99	82 / 99	82 / 99	82 / 99	99	99	99	99	99	99	99	
Size - Outdoor unit																	
Power supply				Voltage/Frequency/Phases	V/Hz/n°	230/50/1											
Sound power				Minimum / Nominal	dB(A)	50 / 55	51 / 57	52 / 58	52 / 60	54 / 63	54 / 64	54 / 66					
Sound pressure @1m				Minimum / Nominal	dB(A)	37 / 42	38 / 44	39 / 45	39 / 47	41 / 50	41 / 51	41 / 53					
Operating range																	
Water supply temperature	Heating / DHW	Full electric	Minimum / Maximum	°C	25 / 65	25 / 65	25 / 65	25 / 65	25 / 65	25 / 65	25 / 65	25 / 65	25 / 65	25 / 65			
		Hybrid	Minimum / Maximum	°C	25 / 80	25 / 80	25 / 80	25 / 80	25 / 80	25 / 80	25 / 80	25 / 80	25 / 80	25 / 80			
Operating range (outdoor air)	Cooling	-	Minimum / Maximum	°C	5 / 25	5 / 25	5 / 25	5 / 25	5 / 25	5 / 25	5 / 25	5 / 25	5 / 25				
		Heating	-	Minimum / Maximum	°C	-25 / 35	-25 / 35	-25 / 35	-25 / 35	-25 / 35	-25 / 35	-25 / 35	-25 / 35				
Operating range (outdoor air)	DHW	-	Minimum / Maximum	°C	-25 / 43	-25 / 43	-25 / 43	-25 / 43	-25 / 43	-25 / 43	-25 / 43	-25 / 43	-25 / 43				
		Cooling	-	Minimum / Maximum	°C	-5 / 43	-5 / 43	-5 / 43	-5 / 43	-5 / 43	-5 / 43	-5 / 43	-5 / 43				

Data according to EN 14511:2022 and EN 14825:2022
The Product complies with the European ErP Directive (EU Regulations 811/2013 - 813/2013 - 2016/2281).

Standard power supply: G20 (100% natural gas). Power supply with optional kit: G30 / G31 (LPG gas)

Size - Set (400TN version)					6.1	7.1	8.1	
HYFE boiler					34	34	34	
	Capacity	Water 35/30 °C	Nominal / Maximum	kW	12,1 / 14,6	14,5 / 15,5	16,0 / 16,8	
	COP	Outdoor air 7 °C	Nominal	-	5,00	4,70	4,55	
Heating Heat pump	Capacity	Water 35/30 °C	Nominal / Maximum	kW	10,5 / 13,9	12,2 / 14,1	13,4 / 14,3	
	COP	Outdoor air -7 °C	Nominal	-	3,13	2,82	2,74	
	Capacity	Water 45/40 °C	Nominal / Maximum	kW	12,3 / 14,5	14,0 / 15,7	16,0 / 16,6	
	COP	Outdoor air 7 °C	Nominal	-	3,80	3,65	3,60	
Heating Heat pump	Nominal Heating capacity ((LHV)	Water 80/60 °C	Nominal	kW	34,0	34,0	34,0	
	Efficiency		Nominal	%	97,7	97,7	97,7	
Cooling	Capacity	Water 18/23 °C	Nominal / Maximum	kW	12,1 / 15,0	13,8 / 15,3	14,8 / 16,4	
	EER	Outdoor air 35 °C	Nominal	-	4,02	3,70	3,65	
	Capacity	Water 7/12 °C	Nominal / Maximum	kW	11,8 / 11,8	12,9 / 12,9	14,2 / 14,2	
	EER	Outdoor air 35 °C	Nominal	-	2,75	2,55	2,45	
ACS Boiler	Capacity		Maximum	kW	34,0	34,0	34,0	
	Specific flow rate	Water with ΔT=30 °C in 10 minutes		l/min	16,0	16,0	16,0	
Electrical power for meter sizing					kW	5,40	5,70	6,10
Seasonal efficiency Medium climate	Energy class			-	A++	A++	A++	
	Heating Water 55 °C	Annual energy consumption		kWh/year	6.793	7.380	7.915	
		SCOP		-	3,56	3,52	3,48	
		ns (seasonal output)		%	139	138	136	
	Energy class			-	A+++	A+++	A+++	
	Heating Water 35 °C	Annual energy consumption		kWh/year	4.994	5.868	6.602	
		SCOP		-	5,00	4,91	4,89	
		ns (seasonal output)		%	196	193	193	
DHW Boiler	Energy class			-	A	A	A	
	Withdrawal profile			-	XXL	XXL	XXL	
Size - Indoor unit					B	C	D	
Power supply	Voltage/Frequency/Phases			V/Hz/n°		230/50/1		
Water flow-rate	Water 35/30 °C		Nominal	l/s	0,57	0,67	0,75	
Pump available pressure	Outdoor air 7 °C		Nominal	kPa	25,7	31,7	22,6	
Minimum system water content					l	40	40	40
Expansion tank capacity					l	10	10	10
Sound power	Operation:		Nominal	dB(A)	41 / 46	41 / 46	41 / 46	
Sound pressure @1m	heat pump only / heat pump + boiler		Nominal	dB(A)	28 / 33	28 / 33	28 / 33	
HYFE boiler					34	34	34	
Power supply	Voltage/Frequency/Phases			V/Hz/n°	230/50/1	230/50/1	230/50/1	
Power input	Water content			W	99	99	99	
Size - Outdoor unit					6.1	7.1	8.1	
Power supply	Voltage/Frequency/Phases			V/Hz/n°		230/50/1		
Sound power			Minimum / Nominal	dB(A)	54 / 63	54 / 64	54 / 66	
Sound pressure @1m			Minimum / Nominal	dB(A)	41 / 50	41 / 51	41 / 53	
Operating range								
Water supply temperature	Heating / DHW	Full electric	Minimum / Maximum	°C	25 / 65	25 / 65	25 / 65	
		Hybrid	Minimum / Maximum	°C	25 / 80	25 / 80	25 / 80	
Operating range (Outdoor air)	Cooling	-	Minimum / Maximum	°C	5 / 25	5 / 25	5 / 25	
		-	Minimum / Maximum	°C	-25 / 35	-25 / 35	-25 / 35	
Operating range (Outdoor air)	DHW	-	Minimum / Maximum	°C	-25 / 43	-25 / 43	-25 / 43	
		-	Minimum / Maximum	°C	-5 / 43	-5 / 43	-5 / 43	

Data according to EN 14511:2022 and EN 14825:2022.
The Product complies with the European ErP Directive (EU Regulations 811/2013 - 813/2013 - 2016/2281).

Standard power supply: G20 (100% natural gas). Power supply with optional kit: G30 / G31 (LPG gas)

Dimensions and connections

Size				2.1	3.1	4.1	5.1	6.1	7.1	8.1
Dimensions	Indoor unit	AxCxB	mm	450x1.086x410	450x1.086x410	450x1.086x410	450x1.086x410	450x1.086x410	450x1.086x410	450x1.086x410
	Outdoor unit	AxCxB	mm	920x712x400	920x712x400	1.042x866x444	1.042x866x444	1.042x866x444	1.042x866x444	1.042x866x444
Weight	Indoor unit		kg	39	39	39	39	41	41	41
	Boiler - 24 kW		kg	31	31	31	31	-	-	-
	Boiler - 34 kW		kg	34	34	34	34			
	Outdoor unit		kg	58	58	77	77	112	112	112
Max / min equivalent length	L	m		30 / 2	30 / 2	30 / 2	30 / 2	30 / 2	30 / 2	30 / 2
Max difference in level ODU / IDU	H	m		25	25	25	25	25	25	25
Refrigerant precharge		type / GWP		R-32 / 675	R-32 / 675	R-32 / 675	R-32 / 675	R-32 / 675	R-32 / 675	R-32 / 675
		kg		1,50	1,50	1,65	1,65	1,84	1,84	1,84
		CO ₂ tons		1,05	1,05	1,10	1,10	1,24	1,24	1,24
Equivalent pipe length with pre-charging only			m	15	15	15	15	15	15	15
Refrigerant piping	Liquid	inch		1/4"	1/4"	3/8"	3/8"	3/8"	3/8"	3/8"
	Gas	inch		5/8"	5/8"	5/8"	5/8"	5/8"	5/8"	5/8"
External diameters	Indoor unit	Water (System)	inch	1"	1"	1"	1"	1"	1"	1"
		Water (DHW)	inch	3/4"	3/4"	3/4"	3/4"	3/4"	3/4"	3/4"
	Boiler	Gas	inch	3/4"	3/4"	3/4"	3/4"	3/4"	3/4"	3/4"
		Intake air	mm	80	80	80	80	80	80	80
	Exhaust gas	mm	80	80	80	80	80	80	80	

Check in the manual if the indoor unit requires a minimum installation surface

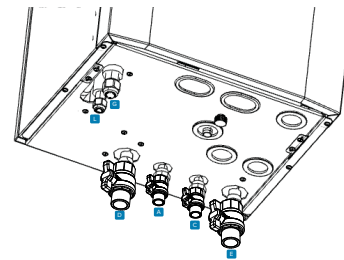
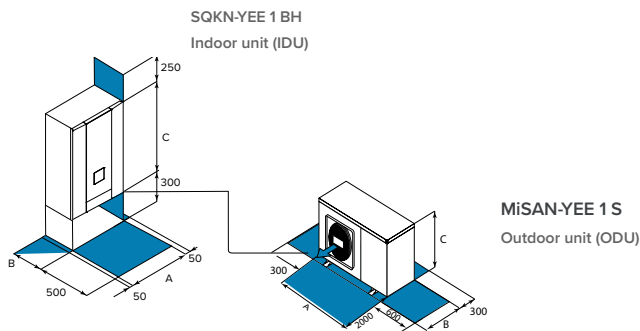

- L** Refrigerant - liquid pipe
- G** Refrigerant - gas pipe
- TO** Domestic hot water (DHW) - supply to external heat exchanger
- C** Domestic hot water (DHW) - return to external heat exchanger
- D** System - Water return
- E** System - Water supply

For trouble-free operation of the unit it is essential to maintain the safety distances indicated by the blue areas.

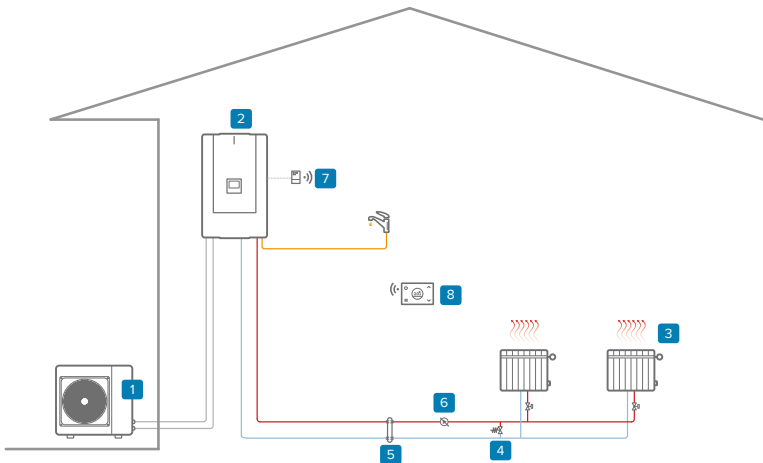

Hybrid single-zone system:
Heating / DHW

- 1 Outdoor unit
- 2 Hybrid indoor unit
- 3 Heating area
- 4 Bypass*
- 5 Hydraulic separator (optional)
- 6 Secondary circuit pump*
- 7 SwitchConnect Wi-Fi receiver (optional)
- 8 HID-TConnect2 Wi-Fi chronothermostat (optional)

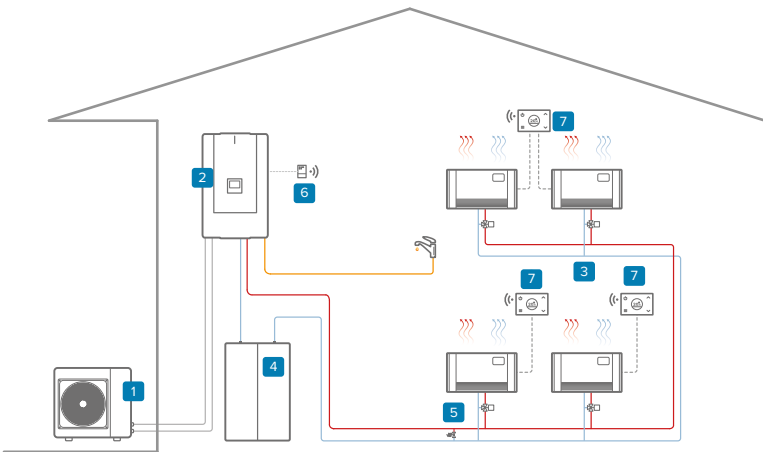

Hybrid single-zone system:
Heating / Cooling / DHW

- 1 Outdoor unit
- 2 Hybrid indoor unit
- 3 heating/cooling zone
- 4 System inertial storage (optional)
- 5 Bypass*
- 6 SwitchConnect Wi-Fi receiver (optional)
- 7 HID-TConnect2 Wi-Fi chronothermostat (optional)

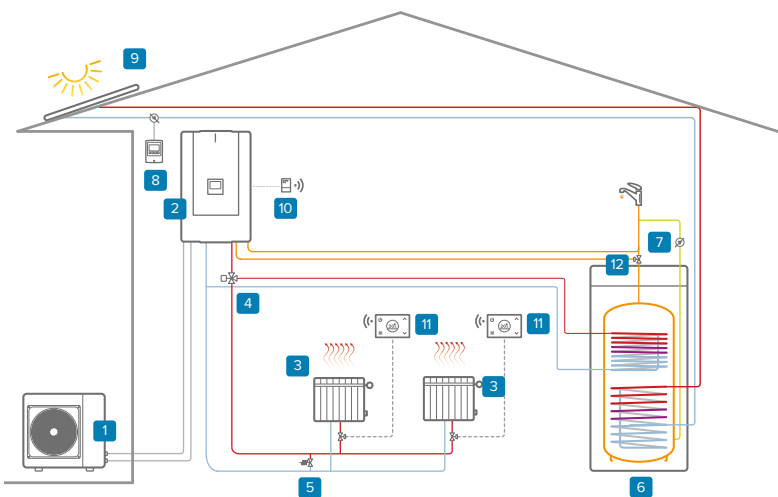

Hybrid single-area system with thermal solar:
Heating / Cooling / DHW

- 1 Outdoor unit
- 2 Hybrid indoor unit
- 3 Heating area
- 4 3-way diverting valve (optional)
- 5 Bypass*
- 6 DHW boiler with solar coil (optional)
DHW recirculation pump*
Solar circulation kit (optional)
- 8 ELFOSun3 thermal solar (optional)
- 9 SwitchConnect Wi-Fi receiver (optional)
- 10 HID-TConnect2 Wi-Fi chronothermostat (optional)
- 11 (optional)
Thermostatic switching valve for DHW
- 12 (optional)

The diagrams are for illustrative purposes only, showing possible combinations of system elements.

*from external supply

SPHERA EVO 2.0 EASYHYBRID TOWER

Air-to-water Refrigerant-split hybrid heat pump with DHW tank for heating, cooling and domestic hot water production

TH configuration with accessories cabinet

Capacity from 4 to 16 kW



HEAT PUMPS

Energy saving



Solar integration (DHW tank - optional)



€-Switch

Comfort



Hot Cold



DHW



Silent

Convenience



Weekly Timer



Instant DHW (Hybrid Version)



Integrated DHW tank

Management and connectivity



Input ON/OFF



Port Modbus



Control via App



management CONTROL4 NRG



Clivet Eye monitoring

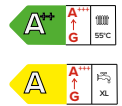

- ✓ Optimised to maximise energy savings without sacrificing comfort
- ✓ Compatible with a radiator system: water temperature up to 80 °C
- ✓ Customisable with numerous kits for a complete, yet discreet, central heating plant
- ✓ Domestic hot water volume can be increased to up to 300 litres
- ✓ Connectivity and the APP to keep the system under control

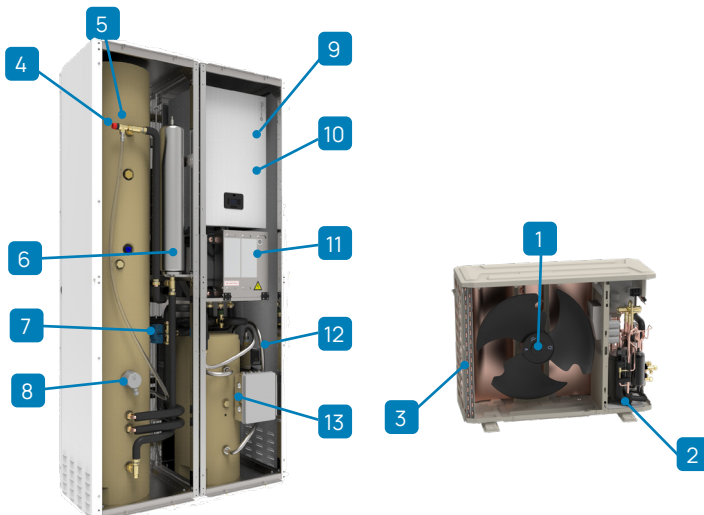

- 1 Inverter DC fan
- 2 Inverter DC twin-rotary compressor
- 3 Air-gas finned exchanger (blue fin treatment)
- 4 DHW pressure relief valve
- 5 150 L DHW tank with coil
- 6 8-litre DHW expansion tank
- 7 3-way valve
- 8 2kW DHW safety heater
- 9 Instantaneous condensing boiler
- 10 8- or 10-litre system expansion tank
- 11 Electrical control panel
- 12 1-zone booster kit (optional)
- 13 System inertial storage kit (optional)

Flexible and compact

Sphera EVO 2.0 EASYHybrid Tower has the indoor Box unit fitted into modular units, so you can create the perfect solution for your system. Each module can be created and customised with all the necessary components for an efficient and reliable system, all inside a compact cabinet with an appearance that blends in with the environment in which it is installed.

Configurations























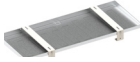

POWER INPUT OUTDOOR UNIT (GR. 6.1+8.1):

220M	Power supply 230/1/20 (standard)
400TN	Power supply 400/3/50+N

INTEGRATED CONDENSING BOILER:

HYFE24	24 kW instantaneous boiler
HYFE34	34 kW instantaneous boiler

Accessories

	TUNOX	Main aesthetic cabinet for Sphera EVO 2.0 EASYHybrid		KPRSX	DHW recirculation pump kit (for installation inside the unit)
	TDUEX	Additional 150 liter DHW tank with aesthetic cabinet		ANEDX	Electronic anode to protect DHW boiler
	TDUESX	Additional 150 liter DHW tank with solar coil with aesthetic cabinet		KSDFX	Splitter for suction and flue gas discharge (d. 80/80 mm)
	KCACSX	Pipe connection kit for TDUEX, TDUESX accessories		KCSAFX	Vertical coaxial fitting for smoke intake and discharge (d. 60/100 mm)
	TTREX	Additional aesthetic cabinet for system accessories		CCOAX	90° coaxial curve for suction and flue gas discharge, 360° adjustable (d. 60/100 mm)
	TTREAX	Second additional 150 liter DHW tank with aesthetic cabinet		TCOAX	1 m coaxial pipe with terminal (d. 60/100 mm)
	KC150X	Pipe connection kit for TTREAX accessory		3DHWX	3-way deviating valve for system/ DHW 1" connections
	SRICX	Additional PCB for 2-zone management		DTX	Drain pan with antifreeze electrical heater
	KCSIX	Kit for secondary circuit for installation inside the unit (1 liter circuit breaker + circulation pump + management PCB)		APAVX	Kit of antivibration mounts for floor installation
	KIR2HLX	Two-zone distribution kit management PCB: direct + mixed (for installation inside the unit)		ASTFX	Antivibration mounts kit for installation on the brackets for wall installation or drain pan
	KIR2HX	Two-zone distribution kit with management PCB: direct + direct (for installation inside the unit)		KSIPX	Kit with wall fixing brackets
	AC50X	50 liter system inertial storage tank with connection kit for EASYHybrid (for installation inside the unit)		KCVEX	Solar kit: circulation unit, control unit and expansion vessel
				HTC2WX	White HID-TConnect ² chronothermostat for temperature control
				SWCX	Receiver / IoT switch SwitchConnect

Technical data

Size				2.1		3.1		4.1		5.1		6.1		7.1		8.1			
HYFE boiler				24	34	24	34	24	34	24	34	34	34	34	34	34	34		
Heating	Capacity	Water 35/30 °C	Nominal / Maximum	kW		4,32 / 6,26		6,18 / 7,41		8,30 / 9,11		10,1 / 10,3		12,1 / 14,6		14,5 / 15,5		16,0 / 16,8	
	COP	Outdoor air 7 °C	Nominal	-		5,42		5,21		5,31		5,01		5,00		4,70		4,55	
Heat pump	Capacity	Water 35/30 °C	Nominal / Maximum	kW		4,17 / 6,25		6,05 / 6,97		7,33 / 8,35		8,20 / 9,30		10,5 / 13,9		12,2 / 14,1		13,4 / 14,3	
	COP	Outdoor air -7 °C	Nominal	-		3,16		3		3,23		3,07		3,13		2,82		2,74	
Heating Boiler	Capacity	Water 45/40 °C	Nominal / Maximum	kW		4,16 / 5,96		6,03 / 7,13		8,22 / 8,98		10,0 / 10,3		12,3 / 14,5		14,0 / 15,7		16,0 / 16,6	
	COP	Outdoor air 7 °C	Nominal	-		3,93		3,83		3,95		3,86		3,80		3,65		3,60	
Cooling	Nominal Heating capacity ((LHV)	Water 80/60 °C	Nominal	kW		24,0 34,0		24,0 34,0		24,0 34,0		24,0 34,0		34,0		34,0		34,0	
	Efficiency		Nominal	%		97,8 97,7		97,8 97,7		97,8 97,7		97,8 97,7		97,7		97,7		97,7	
DHW Boiler	Capacity	Water 18/23 °C	Nominal / Maximum	kW		4,55 / 6,88		6,44 / 7,65		8,10 / 11,1		10,0 / 12,0		12,1 / 15,0		13,8 / 15,3		14,8 / 16,4	
	EER	Outdoor air 35 °C	Nominal	-		6,08		5,24		5,12		4,77		4,02		3,70		3,65	
	Capacity	Water 7/12 °C	Nominal / Maximum	kW		4,26 / 6,14		6,25 / 6,39		7,46 / 7,94		9,10 / 9,10		11,8 / 11,8		12,9 / 12,9		14,2 / 14,2	
	EER	Outdoor air 35 °C	Nominal	-		3,50		3,09		3,33		3,09		2,75		2,55		2,45	
Electrical power for meter sizing	Capacity		Maximum	kW		24,0 34,0		24,0 34,0		24,0 34,0		24,0 34,0		34,0		34,0		34,0	
	Specific flow rate	Water with ΔT= 30 °C in 10 minutes		l/min		13,5 16,0		13,5 16,0		13,5 16,0		13,5 16,0		16,0		16,0		16,0	
Seasonal efficiency Medium climate	Heating Water 55 °C	Energy class		-		A++		A++		A++		A++		A++		A++		A++	
		Annual energy consumption		kWh/year		2.542		3.283		3.824		4.749		6.793		7.380		7.915	
		SCOP		-		3,32		3,54		3,72		3,73		3,56		3,52		3,48	
		ns (seasonal output)		%		130		138		146		146		139		138		136	
	Heating Water 35 °C	Energy class		-		A+++		A+++		A+++		A+++		A+++		A+++		A+++	
DHW Boiler	Annual energy consumption	Annual energy consumption		kWh/year		2.161		2.502		3.141		3.747		4.994		5.868		6.602	
		SCOP		-		5,13		5,15		5,32		5,27		5,00		4,91		4,89	
		ns (seasonal output)		%		202		203		210		208		196		193		193	
	Withdrawal profile			-		XL XXL		XL XXL		XL XXL		XL XXL		XXL		XXL		XXL	
Size - Indoor unit								TO				B		C		D			
Power supply	Voltage/Frequency/Phases		V/Hz/n°									230/50/1							
Water flow-rate	Water 35/30 °C	Nominal	l/s	0,21		0,30		0,41		0,49		0,57		0,67		0,75			
Pump available pressure	Outdoor air 7 °C	Nominal	kPa	31,2		36,5		33,1		31,0		25,7		31,7		22,6			
Minimum system water content			l									40							
Expansion tank capacity			l									8 (HYFE24) / 10 (HYFE34)							
Sound power	Operation:	Nominal	dB(A)									41 / 46							
Sound pressure @1m	heat pump only / heat pump + boiler	Nominal	dB(A)									28 / 33							
HYFE boiler				24	34														
Power supply	Voltage/Frequency/Phases		V/Hz/n°	230/50/1															
Power input	Water content		W	82		99													
Size - Outdoor unit				2.1	3.1	4.1	5.1	6.1	7.1	8.1									
Power supply	Voltage/Frequency/Phases		V/Hz/n°	230/50/1															
Sound power	Minimum / Nominal		dB(A)	50 / 55		51 / 57		52 / 58		52 / 60		54 / 63		54 / 64		54 / 66			
Sound pressure @1m	Minimum / Nominal		dB(A)	37 / 42		38 / 44		39 / 45		39 / 47		41 / 50		41 / 51		41 / 53			
Operating range																			
Water supply temperature	Heating / DHW	Full electric	Minimum / Maximum	°C		25 / 65													
		Hybrid	Minimum / Maximum	°C		25 / 80													
	Cooling	-	Minimum / Maximum	°C		5 / 25													
Operating Voltage Range	Heating	-	Minimum / Maximum	°C		-25 / 35													
	DHW	-	Minimum / Maximum	°C		-25 / 43													
Outdoor air	Cooling	-	Minimum / Maximum	°C		-5 / 43													

Data according to EN 14511:2022 and EN 14825:2022
 The Product complies with the European ErP Directive (EU Regulations 811/2013 - 813/2013 - 2016/2281).

Standard power supply: G20 (100% natural gas). Power supply with optional kit: G30 / G31 (LPG gas)

Size - Set (400TN version)					6.1	7.1	8.1	
HYFE boiler					34	34	34	
Heating Heat pump	Capacity	Water 35/30 °C	Nominal / Maximum	kW	12,1 / 14,6	14,5 / 15,5	16,0 / 16,8	
	COP	Outdoor air 7 °C	Nominal	-	5,00	4,70	4,55	
	Capacity	Water 35/30 °C	Nominal / Maximum	kW	10,5 / 13,9	12,2 / 14,1	13,4 / 14,3	
	COP	Outdoor air -7 °C	Nominal	-	3,13	2,82	2,74	
Heating Boiler	Capacity	Water 45/40 °C	Nominal / Maximum	kW	12,3 / 14,5	14,0 / 15,7	16,0 / 16,6	
	COP	Outdoor air 7 °C	Nominal	-	3,80	3,65	3,60	
Cooling	Nominal Heating capacity ((LHV)	Water 80/60 °C	Nominal	kW	34,0	34,0	34,0	
	Efficiency		Nominal	%	97,7	97,7	97,7	
	Capacity	Water 18/23 °C	Nominal / Maximum	kW	12,1 / 15,0	13,8 / 15,3	14,8 / 16,4	
	EER	Outdoor air 35 °C	Nominal	-	4,02	3,70	3,65	
DHW Boiler	Capacity	Water 7/12 °C	Nominal / Maximum	kW	11,8 / 11,8	12,9 / 12,9	14,2 / 14,2	
	EER	Outdoor air 35 °C	Nominal	-	2,75	2,55	2,45	
Electrical power for meter sizing	Capacity	Maximum	kW	34,0	34,0	34,0		
	Specific flow rate	Water with ΔT=30 °C in 10 minutes	l/min	16,0	16,0	16,0		
Seasonal efficiency Medium climate	Energy class			-	A++	A++	A++	
	Heating Water 55 °C	Annual energy consumption	kWh/year	6.793	7.380	7.915		
		SCOP	-	3,56	3,52	3,48		
		ns (seasonal output)	%	139	138	136		
	Energy class			-	A+++	A+++	A+++	
	Heating Water 35 °C	Annual energy consumption	kWh/year	4.994	5.868	6.602		
		SCOP	-	5,00	4,91	4,89		
		ns (seasonal output)	%	196	193	193		
	DHW Boiler	Energy class			-	A	A	A
		Withdrawal profile			-	XXL	XXL	XXL
Size - Indoor unit					B	C	D	
Power supply	Voltage/Frequency/Phases			V/Hz/n°	230/50/1			
Water flow-rate	Water 35/30 °C	Nominal	l/s	0,57	0,67	0,75		
Pump available pressure	Outdoor air 7 °C	Nominal	kPa	25,7	31,7	22,6		
Minimum system water content				l	40			
Expansion tank capacity				l	10			
Sound power	Operation:	Nominal	dB(A)		41 / 46			
Sound pressure @1m	heat pump only / heat pump + boiler	Nominal	dB(A)		28 / 33			
HYFE boiler					34			
Power supply	Voltage/Frequency/Phases			V/Hz/n°	230/50/1			
Power input	Water content			W	99			
Size - Outdoor unit					6.1	7.1	8.1	
Power supply	Voltage/Frequency/Phases			V/Hz/n°		230/50/1		
Sound power	Minimum / Nominal			dB(A)	54 / 63	54 / 64	54 / 66	
Sound pressure @1m	Minimum / Nominal			dB(A)	41 / 50	41 / 51	41 / 53	
Operating range								
Water supply temperature	Heating / DHW	Full electric	Minimum / Maximum	°C		25 / 65		
		Hybrid	Minimum / Maximum	°C		25 / 80		
	Cooling	-	Minimum / Maximum	°C		5 / 25		
Operating Voltage Range	Heating	-	Minimum / Maximum	°C		-25 / 35		
	DHW	-	Minimum / Maximum	°C		-25 / 43		
Outdoor air	Cooling	-	Minimum / Maximum	°C		-5 / 43		

Data according to EN 14511:2022 and EN 14825:2022
 The Product complies with the European ErP Directive (EU Regulations 811/2013 - 813/2013 - 2016/2281).

Standard power supply: G20 (100% natural gas). Power supply with optional kit: G30 / G31 (LPG gas)

Dimensions and connections

Size			2.1	3.1	4.1	5.1	6.1	7.1	8.1
Dimensions	Indoor unit	AxCxB	mm			1100x2100x530 (TUNOX + TDUEX)			
	Outdoor unit	AxCxB	mm	920x712x400			1.042x866x444		
Operating weight	Indoor unit		kg			325			
	Boiler - 24 kW		kg		31				-
	Boiler - 34 kW		kg			34			
	Outdoor unit		kg	58		77		112	
Max / min equivalent length	L	m				30 / 2			
Max difference in level ODU / IDU	H	m				25			
Refrigerant precharge		type / GWP				R-32 / 675			
		kg		1,50		1,65		1,84	
		CO ₂ tons		1,05		1,10		1,24	
Equivalent pipe length with pre-charging only		m				15			
External diameters	Refrigerant piping	Liquid	inch	1/4"			3/8"		
		Gas	inch			5/8"			
	Indoor unit	Water (System)	inch			1"			
		Water (DHW)	inch			3/4"			
		Gas	inch			3/4"			
	Boiler	Intake air	mm			80			
Exhaust gas		mm			80				

Check in the manual if the indoor unit requires a minimum installation surface

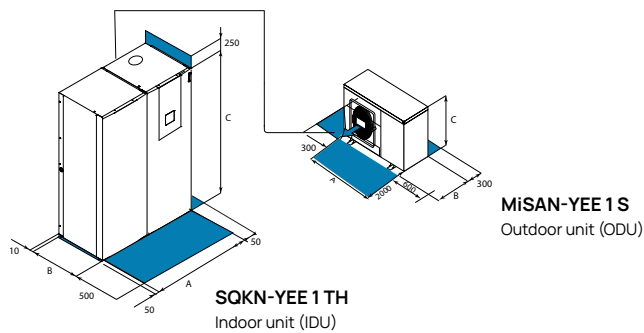

For trouble-free operation of the unit it is essential to maintain the safety distances indicated by the blue areas.

Hybrid single-zone system:
Heating / DHW

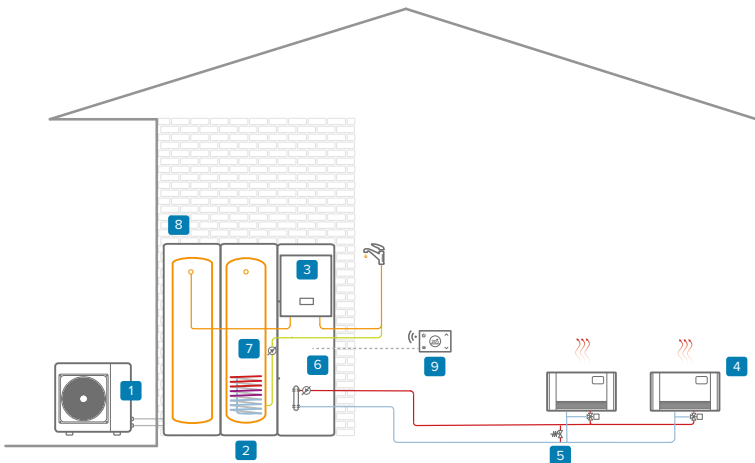

- 1 Outdoor unit
- 2 Indoor unit
- 3 Hybrid module (heat pump / boiler)
- 4 Heating area
- 5 Bypass*
- 6 Kit for secondary circuit (optional)
- 7 DHW circulation pump (optional)
- 8 Additional DHW storage tank (optional)
- 9 HID-TConnect2 Wi-Fi chronothermostat (optional)

Hybrid single-area system with
thermal solar:
Heating / Cooling / DHW

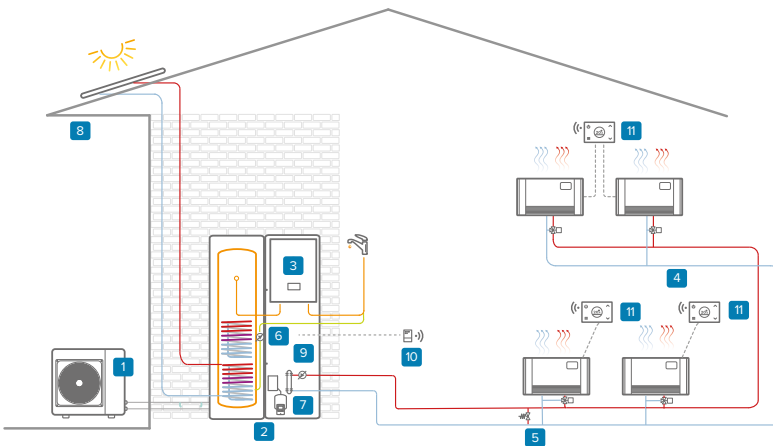

- 1 Outdoor unit
- 2 Indoor unit
- 3 Hybrid module (heat pump / boiler)
- 4 Heating area
- 5 Bypass*
- 6 DHW circulation pump (optional)
- 7 Solar connection kit (optional)
- 8 ELFOSUN3 thermal solar (optional)
- 9 Kit for secondary circuit (optional)
- 10 SwitchConnect Wi-Fi receiver (optional)
- 11 HID-TConnect2 Wi-Fi chronothermostat (optional)

Hybrid single-zone system with
additional DHW boiler:
Heating / Cooling / DHW

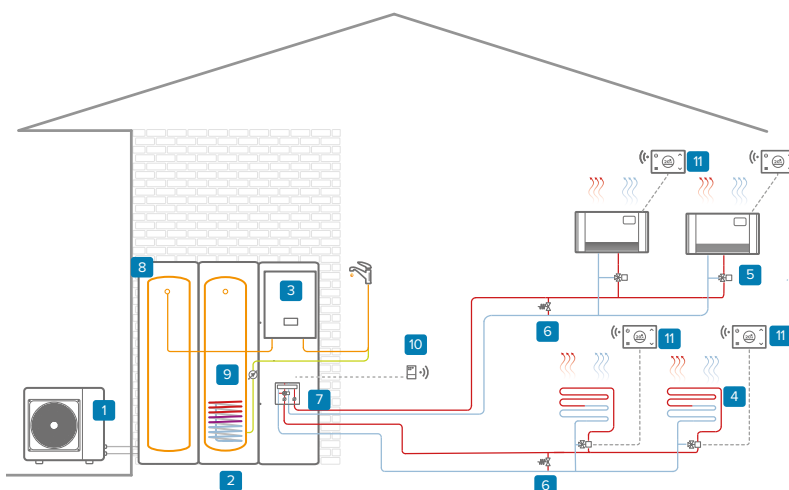

- 1 Outdoor unit
- 2 Indoor unit
- 3 Hybrid module (heat pump / boiler)
- 4 Mixed heating/cooling zone
- 5 Direct heating/cooling zone
- 6 Bypass*
- 7 Kit for managing 2 areas (optional)
- 8 Additional DHW tank (optional)
- 9 DHW circulation pump (optional)
- 10 SwitchConnect Wi-Fi receiver (optional)
- 11 HID-TConnect2 Wi-Fi chronothermostat (optional)

The diagrams are for illustrative purposes only, showing possible combinations of system elements.

*from external supply

MONOBLOC



2.1 Heat pumps



EDGE PRO



EDGE PRO L



EDGE F



EDGE EVO 2.0

EDGE PRO

Air-to-water packaged unit heat pump
for heating, cooling and domestic hot water production

Capacity from 4 to 16 kW



Energy saving



Solar integration (DHW tank - optional)



Cascade



€-Switch

Comfort



Hot Cold



DHW



Silent



Backup heater (optional)

Health



Renewable Energy (Full electric version)

Management and connectivity



Input ON/OFF



User interface/thermostat



Port Modbus



Control via App



management CONTROL4 NRG



Clivet Eye monitoring



Energy metering

Convenience



Weekley Timer



Contemporaneity (Hybrid Version)



Integrated DHW tank

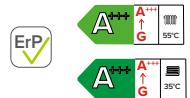

- ✓ Power without the noise: best-in-class quietness
- ✓ Functional, winning design: winner of IF Design Award 2025 and Red Dot Design Award 2025
- ✓ Renovating is easy: flow temperature up to 80°C ideal for any distribution system
- ✓ Advanced management: control up to 6 units in cascade with new advanced functions
- ✓ Reliability and safety guaranteed by new standard components
- ✓ Advanced connectivity: management via dedicated App or via Modbus port with CONTROL4 NRG included as standard

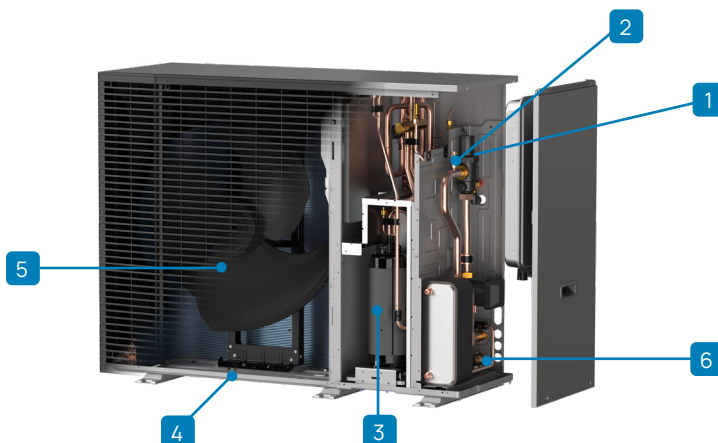

- 1 Air-gas separator
- 2 Hydraulic system pressure sensor
- 3 Silent box
- 4 Base frame electric heater
- 5 Fan design
- 6 Flow meter

HEAT PUMPS

Power without the noise

This heat pump is a valid solution for installations where a high level of quietness is required, thanks to the special design of the fans and the two silent operating modes. Furthermore, in EDGE PRO, the compressor is positioned inside a "silent box" composed of several layers of sound-absorbing material, specifically designed to reduce the compressor noise by up to -25 dB(A).

Configurations





























BACK-UP ELECTRIC HEATER (INTEGRATED IN THE UNIT):

-	No heater (standard)	IBH	Electric back-up heater (only available for 2.1-8.1)
---	----------------------	-----	--

Mandatory accessories

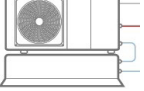
	HMINX	Black KJRH-120L control		NEW KITR290X	Simplified installation kit for R-290 units
	HMIX	White KJRH-120L control			

Accessories

	IBHX	Electric back-up heater (single phase)		DI50-2X	50 liter hydraulic separator
	IBHTX	Electric back-up heater (three-phase)		DI100-2X	100-litre circuit breaker
	3DHWX	System/DHW 3-way switching valve (SV1)		KCSX	Secondary circuit kit (1-litre hydraulic circuit breaker + pump)
	ACS200X	200 liter DHW tank		KIRE2HX	Double zone distribution unit: direct + direct
	ACS300X	300 liter DHW tank		KIRE2HLX	Double zone distribution unit: direct + mixed (with mixing valve)
	ACS500X	500 liter DHW tank		DTX	Condensate collection pan with electric heater
	QERAX	Connection kit for single-phase heater on DHW storage tank (for ACS200/300/500X)		T1BX	DHW temperature probe and additional 10m heating source
	SCS08X	Solar coil for ACS200X/ACS300X DHW tank		T1B30X	DHW temperature probe and additional 30m heating source
	SCS12X	Solar coil for ACS500X DHW tank		AMRX	Kit of antivibration mounts for floor installation
	FDMX	Magnetic dirt separator filter for water distribution systems		ASTFX	Kit of antivibration mounts for installation on wall brackets, inertial tank or tray
	NEW TANKSX	50 L system inertial storage tank		KSIPX	Kit with wall fixing brackets
	NEW TANKMX	75 L system inertial storage tank		HTC2WX	White HID-TConnect2 chronothermostat for temperature control
	NEW TANKLX	100 L system inertial storage tank		SWCX	Receiver / IoT switch SwitchConnect
	KTCAX	Hose kit for connecting the unit to the inertial storage tank			
	VAGX	Safety antifreeze valve for system			
	VDACSX	Thermostat-controlled switching valve for domestic hot water			

Technical data

Size				2.1	3.1	4.1 - 4.1T	5.1 - 5.1T	6.1 - 6.1T	7.1 - 7.1T	8.1 - 8.1T	
Heating	Capacity	Water 35/30 °C	Nominal / Maximum	kW	4,10 / 7,72	6,10 / 8,99	8,00 / 11,6	9,50 / 12,6	12,1 / 15,0	14,0 / 16,3	15,5 / 17,7
	COP	Outdoor air 7 °C	Nominal	-	5,30	5,03	5,25	4,95	4,70	4,50	
	Capacity	Water 35/30 °C	Nominal / Maximum	kW	4,10 / 6,70	6,00 / 7,63	7,00 / 9,12	8,00 / 9,64	10,0 / 12,4	12,0 / 14,6	13,1 / 15,7
	COP	Outdoor air -7 °C	Nominal	-	3,25	3,03	3,25	3,15	3,15	2,80	2,70
Cooling	Capacity	Water 45/40 °C	Nominal / Maximum	kW	4,50 / 7,27	6,40 / 8,51	8,10 / 11,0	9,50 / 12,2	12,3 / 14,5	14,1 / 16,0	15,5 / 17,3
	COP	Outdoor air 7 °C	Nominal	-	4,17	3,91	4,00	3,90	3,90	3,75	3,65
	Capacity	Water 18/23 °C	Nominal / Maximum	kW	4,50 / 8,36	6,50 / 10,8	8,30 / 11,0	10,0 / 11,9	12,0 / 17,1	14,0 / 18,2	16,0 / 18,9
	EER	Outdoor air 35 °C	Nominal	-	5,65	5,51	5,25	4,60	4,60	4,40	4,25
Electrical power for meter sizing	Capacity	Water 7/12 °C	Nominal / Maximum	kW	4,70 / 6,96	6,80 / 9,03	7,50 / 9,19	8,10 / 9,90	11,5 / 13,9	12,4 / 14,9	14,0 / 16,7
	EER	Outdoor air 35 °C	Nominal	-	3,65	3,10	3,35	3,10	3,05	3,00	2,70
Seasonal efficiency Medium climate	Electrical power for meter sizing			kW	2,70	3,00	3,90	4,20	5,90	6,30	6,70
	Energy class			-	A+++	A+++	A+++	A+++	A+++	A+++	A+++
	Heating Water 55 °C	Annual energy consumption		kWh/year	2,647	3,120	4,056	5,145	6,266	7,479	8,013
		SCOP		-	3,91	3,98	4,08	4,02	3,96	3,87	3,87
	ns (seasonal output)			%	153	156	160	158	155	152	152
	Energy class			-	A+++	A+++	A+++	A+++	A+++	A+++	A+++
Heating Water 35 °C	Annual energy consumption		kWh/year	1,984	2,460	3,095	3,889	5,014	6,069	7,009	
	SCOP		-	5,10	5,00	5,35	5,33	4,94	4,76	4,72	
ns (seasonal output)			%	206	199	211	210	195	188	186	
Technical specifications											
Power supply		Voltage/Frequency/Phases		V/Hz/n°	230/50/1			230/50/1 - 400/50/3+N			
Water flow-rate		Water 35/30 °C	Nominal	l/s	0,20	0,30	0,40	0,50	0,60	0,70	0,70
Pump available pressure		Outdoor air 7 °C	Nominal	kPa	56	56	51	51	45	42	38
Minimum system water content				l	40						
Sound power			Minimum / Nominal	dB(A)	46 / 48	46 / 50	47 / 52	47 / 52	48 / 52	48 / 55	48 / 56
Sound pressure @1m			Nominal	dB(A)	31 / 33	32 / 34	33 / 35	35 / 37	38 / 37	38 / 40	39 / 41
Operating range											
Water supply temperature	Heating / DHW	Full electric	Minimum / Maximum	°C	25 / 80						
	Cooling	-	Minimum / Maximum	°C	5 / 25						
Operating range (Outdoor air)	Heating	-	Minimum / Maximum	°C	-25 / 46						
	Cooling	-	Minimum / Maximum	°C	-5 / 46						

Data according to EN 14511:2022 and EN 14825:2022
The Product complies with the European ErP Directive (EU Regulations 811/2013 - 813/2013 - 2016/2281).

HEAT PUMPS

Dimensions and connections

Size			2.1	3.1	4.1 - 4.1T	5.1 - 5.1T	6.1 - 6.1T	7.1 - 7.1T	8.1 - 8.1T
Dimensions	AxCxB	mm	1.330x1.051x528	1.330x1.051x528	1.330x1.051x528	1.330x1.051x528	1.330x1.051x528	1.330x1.051x528	1.330x1.051x528
Weight		kg	150	150	155 - 160	155 - 160	175 - 180	175 - 180	175 - 180
Refrigerant charge		type / GWP	R-290 / 0,02						
		kg	0,42		0,64	0,69	0,89	1,00	1,08
External diameters	Water				0,00002			0,00003	
			inch			1" 1/4			

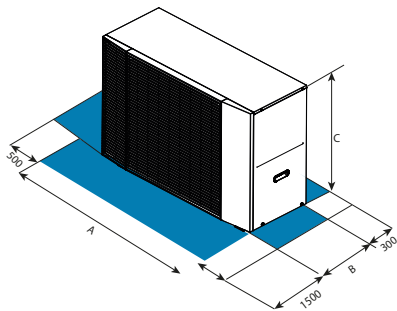

WiSAN-PMP 1 S 2.1-8.1
Outdoor unit (ODU)

For trouble-free operation of the unit it is essential to maintain the safety distances indicated by the blue areas.

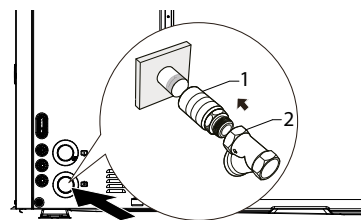
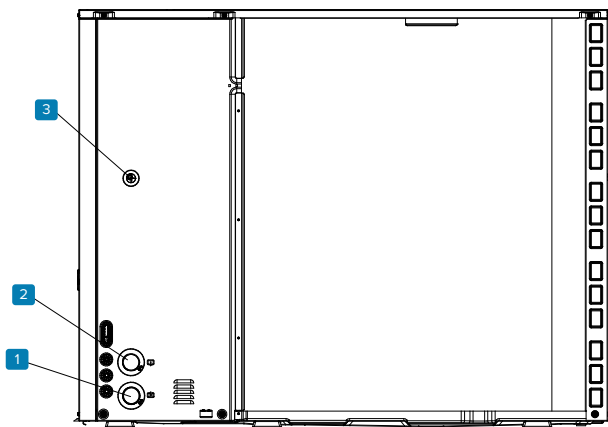

- 1 System supply 1 1/4"
- 2 System return 1 1/4"
- 3 Water side safety valve Ø 16mm

EDGE PRO L

Air-to-water packaged unit heat pump for heating, cooling and domestic hot water production

Capacity from 25 to 30 kW



HEAT PUMPS

Energy saving



Solar integration (DHW tank - optional)



Cascade

Comfort



Hot Cold



DHW



Silent



Backup heater (optional)

Reliability



Renewable Energy (Full electric version)

Health

Management and connectivity



Input ON/OFF



User interface/thermostat



Port Modbus



Control via App



management CONTROL4 NRG



Clivet Eye monitoring



Energy metering

Convenience



Weekley Timer



Contemporaneity (Hybrid Version)



Integrated DHW tank

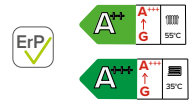

- ✓ Guaranteed performance: Thanks to the scroll compressor with injection technology (EVI), it guarantees excellent performance under all conditions
- ✓ Functional, winning design: winner of IF Design Award 2025 and Red Dot Design Award 2025
- ✓ Renovation is easy: supply temperature up to 85 °C, perfect for any distribution system
- ✓ Advanced management: control up to 6 units in cascade with new advanced functions
- ✓ Reliability and safety guaranteed by new standard components
- ✓ Advanced connectivity: management via dedicated App or via Modbus port with CONTROL4 NRG included as standard



- 1 Injection scroll compressor
- 2 Intermediate heat exchanger
- 3 Hermetic control panel
- 4 Base frame electric heater
- 5 Grille design
- 6 Flow meter

When the cold gets serious



Its strength lies in the scroll compressor with EVI (Enhanced Vapour Injection) technology, which maintains the nominal capacity down to 10 °C outdoor air temperature. In other words, it guarantees constant comfort and performance even when the cold gets serious.

Configurations















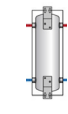

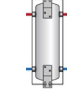

BACK-UP ELECTRIC HEATER (INTEGRATED IN THE UNIT):

- No heater (standard)

Mandatory accessories

	HMINX	Black KJRH-120L control		NEW KITR290X	Simplified installation kit for R-290 units
	HMIX	White KJRH-120L control			

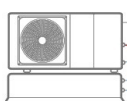
Accessories

	IBHX	Electric back-up heater (single phase)		NEW DEGAX	High-efficiency deaerator
	IBHTX	Electric back-up heater (three-phase)		VDACSX	Thermostat-controlled switching valve for domestic hot water
	3DHWX	System/DHW 3-way switching valve (SV1)		DI50-2X	50 liter hydraulic separator
	ACS200X	200 liter DHW tank		DI100-2X	100-litre circuit breaker
	ACS300X	300 liter DHW tank		DTX	Condensate collection pan with electric heater
	ACS500X	500 liter DHW tank		T1BX	DHW temperature probe and additional 10m heating source
	QERAX	Connection kit for single-phase heater on DHW storage tank (for ACS200/300/500X)		T1B30X	DHW temperature probe and additional 30m heating source
	SCS08X	Solar coil for ACS200X/ACS300X DHW tank		AMRX	Kit of antivibration mounts for floor installation
	SCS12X	Solar coil for ACS500X DHW tank		HTC2WX	White HID-TConnect2 chronothermostat for temperature control
	FDMX	Magnetic dirt separator filter for water distribution systems		SWCX	Receiver / IoT switch SwitchConnect
	NEW TANKSX	50 L system inertial storage tank			
	NEW TANKMX	75 L system inertial storage tank			
	NEW TANKLX	100 L system inertial storage tank			
	KTCAX	Hose kit for connecting the unit to the inertial storage tank			
	VAGX	Safety antifreeze valve for system			

Technical data

Size					12.1	14.1
Heating	Capacity	Water 35/30 °C	Nominal / Maximum	kW	25,0 / 28,7	30,1 / 31,6
	COP	Outdoor air 7 °C	Nominal	-	4,77	4,50
	Capacity	Water 35/30 °C	Nominal / Maximum	kW	21,0 / 26,1	24,0 / 29,0
	COP	Outdoor air -7 °C	Nominal	-	3,03	2,86
Cooling	Capacity	Water 45/40 °C	Nominal / Maximum	kW	25,0 / 29,1	30,1 / 32,8
	COP	Outdoor air 7 °C	Nominal	-	3,81	3,63
	Capacity	Water 18/23 °C	Nominal / Maximum	kW	26,0 / 38,3	30,1 / 40,9
	EER	Outdoor air 35 °C	Nominal	-	4,64	4,41
Electrical power for meter sizing	Capacity	Water 7/12 °C	Nominal / Maximum	kW	26,0 / 27,0	30,1 / 31,6
	EER	Outdoor air 35 °C	Nominal	-	3,10	2,80
					kW	14,5
Seasonal efficiency Medium climate	Heating Water 55 °C	Energy class	-	-	A+++	-
		SCOP	-	-	3,84	3,79
	Heating Water 35 °C	ns (seasonal output)	%	-	151	149
		Energy class	-	-	A+++	A++
		SCOP	-	-	4,95	4,92
		ns (seasonal output)	%	-	195	194
Technical specifications						
Power supply	Voltage/Frequency/Phases		V/Hz/n°	400/50/3+N		
Water flow-rate	Water 35/30 °C	Nominal	l/s	1,20	1,44	
Pump available pressure	Outdoor air 7 °C	Nominal	kPa	92	66	
Minimum system water content				l	100	
Sound power			Minimum / Nominal	dB(A)	63 / 68	63 / 74
Sound pressure @1m			Nominal	dB(A)	45 / 55	47 / 61
Operating range						
Water supply temperature	Heating / DHW	Full electric	Minimum / Maximum	°C	20 / 85	
	Cooling	-	Minimum / Maximum	°C	0 / 25	
Operating range (Outdoor air)	Heating	-	Minimum / Maximum	°C	-25 / 43	
	Cooling	-	Minimum / Maximum	°C	-15 / 48	

Data according to EN 14511:2022 and EN 14825:2022
The Product complies with the European ErP Directive (EU Regulations 811/2013 - 813/2013 - 2016/2281).

Dimensions and connections

Size	12.1		14.1	
Dimensions	AxCxB	mm	1.388x1.816x556	
Weight		kg	279	
Refrigerant charge		type / GWP	R-290 / 0,02	
		kg	2.90	
External diameters	Water	CO ₂ tons	0,00006	
		inch	1" 1/4	

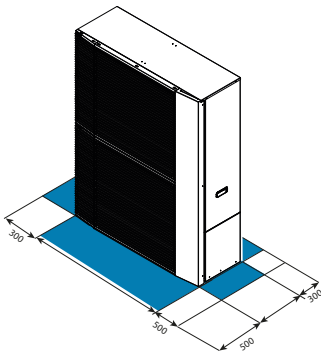

WiSAN-PMP 1 S 12.1 - 14.1
Outdoor unit (ODU)

For trouble-free operation of the unit it is essential to maintain the safety distances indicated by the blue areas.

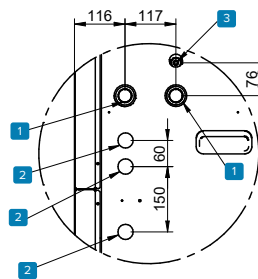
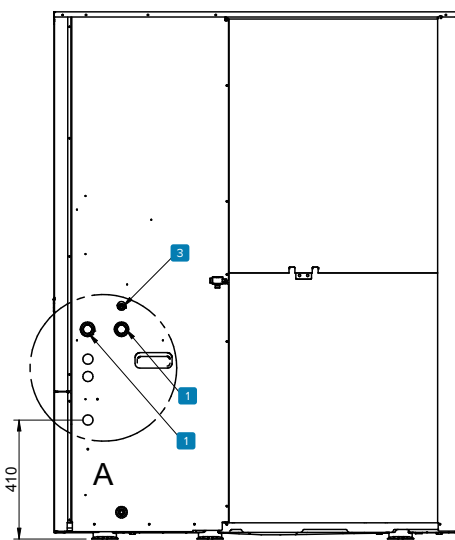

- 1 Water connections
- 2 Electrical line inlet
- 3 Water safety valve drain

EDGE F

Air-to-water packaged unit heat pump
for heating, cooling and domestic hot water production

Capacity from 4 to 15 kW

HEAT PUMPS



Energy saving

- Solar integration (DHW tank - optional)
- Cascade
- Smart Grid ready
- €-Switch

Comfort

- Hot Cold
- DHW
- Silent

Reliability

- Backup heater (optional)
- 041
- ProdottiQualità CasaClima

Health

- Renewable Energy (Full electric version)
- Eco-friendly refrigerant

Management and connectivity

- Input ON/OFF
- User interface/thermostat
- Port Modbus
- Control via App
- management CONTROL4 NRG
- Clivet Eye monitoring
- Energy metering

Convenience

- Weekly Timer
- Contemporaneity (Hybrid Version)
- Integrated DHW tank

ErP

- ✓ R-290 technology: combines high performance with full respect for the environment
- ✓ Versatile: wide range of applications in both packaged and hydro-split versions
- ✓ Renovation is easy: supply temperature up to 75 °C, perfect for any distribution system
- ✓ Modular: combines up to 6 units in cascade
- ✓ Advanced connectivity: management via the dedicated App or via the Modbus port with CONTROL4 NRG standard supplied

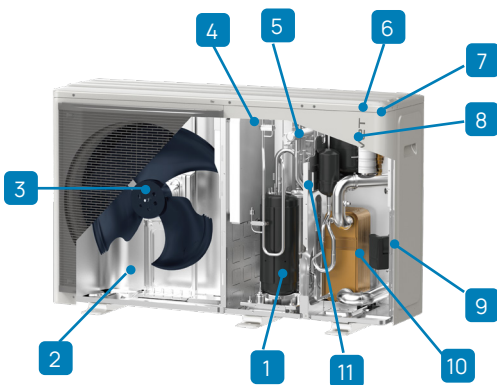

- 1 Compressor
- 2 Source side exchanger
- 3 Fan
- 4 Sealed inverter panel
- 5 4-way reverse cycle valve
- 6 Relief valve (safety)
- 7 Sealed electrical panel
- 8 System expansion vessel (4.8 litres)
- 9 Water supply pump
- 10 User side exchanger
- 11 Lamination valve

For the future

Edge F is the heat pump with R-290 refrigerant designed for the future, it is in fact a natural gas, and already in accordance with the current strict European regulations. The high thermodynamic qualities of this new refrigerant allow the production of water at unprecedented temperatures, 75 °C supply down to -10 °C ambient.



Respect for the environment and temperatures comparable to a boiler for a full-electric future.

Configurations











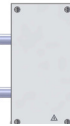

















BACK-UP ELECTRIC HEATER (INTEGRATED IN THE UNIT):

-	No heater (standard)	IBH	Electric back-up heater (only available for 2.1-8.1)
---	----------------------	-----	--

Mandatory accessories

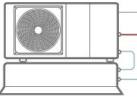
	HMINX	Black KJRH-120L control		NEW KITR290X	Simplified installation kit for R-290 units
	HMIX	White KJRH-120L control			

Accessories

	IBHX	Electric back-up heater (single phase)		VDACSX	Thermostat-controlled switching valve for domestic hot water
	IBHTX	Electric back-up heater (three-phase)		DI50-2X	50 liter hydraulic separator
	3DHWX	System/DHW 3-way switching valve (SV1)		DI100-2X	100-litre circuit breaker
	ACS200X	200 liter DHW tank		KCSX	Secondary circuit kit (1-litre hydraulic circuit breaker + pump)
	ACS300X	300 liter DHW tank		KIRE2HX	Double zone distribution unit: direct + direct
	ACS500X	500 liter DHW tank		KIRE2HLX	Double zone distribution unit: direct + mixed (with mixing valve)
	QERAX	Connection kit for single-phase heater on DHW storage tank (for ACS200/300/500X)		DTX	Condensate collection pan with electric heater
	SCS08X	Solar coil for ACS200X/ACS300X DHW tank		T1BX	DHW temperature probe and additional 10m heating source
	SCS12X	Solar coil for ACS500X DHW tank		T1B30X	DHW temperature probe and additional 30m heating source
	FDMX	Magnetic dirt separator filter for water distribution systems		AMRX	Kit of antivibration mounts for floor installation
	NEW TANKSX	50 L system inertial storage tank		ASTFX	Kit of antivibration mounts for installation on wall brackets, inertial tank or tray
	NEW TANKMX	75 L system inertial storage tank		KSIPX	Kit with wall fixing brackets
	NEW TANKLX	100 L system inertial storage tank		HTC2WX	White HID-TConnect2 chronothermostat for temperature control
	KTCAX	Hose kit for connecting the unit to the inertial storage tank		SWCX	Receiver / IoT switch SwitchConnect
	VAGX	Safety antifreeze valve for system			

Technical data

Size				2.1	3.1	4.1	5.1	6.1 - 6.1T	7.1 - 7.1T	8.1 - 8.1T	
Heating	Capacity	Water 35/30°C	Nominal / Maximum	kW	4,50 / 6,86	6,20 / 7,70	8,40 / 10,4	10,0 / 11,0	12,0 / 14,7	14,0 / 16,0	15,0 / 17,6
	COP	Outdoor air 7°C	Nominal	-	5,15	4,90	5,00	4,70	4,80	4,50	4,40
	Capacity	Water 35/30°C	Nominal / Maximum	kW	4,50 / 5,56	5,90 / 6,18	7,00 / 8,74	8,00 / 8,89	10,0 / 11,1	11,5 / 12,1	12,7 / 13,2
	COP	Outdoor air -7°C	Nominal	-	3,10	2,95	3,00	2,85	2,80	2,70	2,50
Cooling	Capacity	Water 45/40°C	Nominal / Maximum	kW	4,50 / 6,55	6,40 / 7,35	8,20 / 9,57	10,0 / 10,5	12,0 / 14,1	14,0 / 15,3	15,0 / 16,9
	COP	Outdoor air 7°C	Nominal	-	4,05	3,80	3,85	3,65	3,70	3,50	3,35
	Capacity	Water 18/23°C	Nominal / Maximum	kW	4,50 / 7,84	6,50 / 9,75	8,30 / 11,4	10,0 / 12,1	12,0 / 16,4	14,0 / 17,3	16,0 / 18,6
	EER	Outdoor air 35°C	Nominal	-	5,50	5,10	5,15	4,75	4,50	4,20	3,90
Electrical power for meter sizing	Capacity	Water 7/12°C	Nominal / Maximum	kW	4,70 / 5,66	6,80 / 7,14	7,50 / 8,19	8,90 / 8,90	11,5 / 12,0	12,7 / 12,7	14,0 / 14,3
	EER	Outdoor air 35°C	Nominal	-	3,65	3,10	3,45	3,25	3,05	2,90	2,75
Electrical power for meter sizing				kW	2,70	3,00	3,60	3,90	5,70	6,00	6,40
Seasonal efficiency Medium climate	Energy class			-	A++	A++	A++	A++	A++	A++	A++
	Heating Water 55°C	Annual energy consumption		kWh/year	2.684	3.164	3.676	4.215	6.847	7.414	8.349
		SCOP		-	3,79	3,82	3,82	3,82	3,62	3,62	3,57
	ns (seasonal output)			%	149	150	150	150	142	142	140
	Energy class			-	A+++	A+++	A+++	A+++	A+++	A+++	A+++
	Heating Water 35°C	Annual energy consumption		kWh/year	2.040	2.692	3.187	3.734	5.376	6.091	6.630
		SCOP		-	5,09	4,91	5,20	5,07	4,68	4,64	4,59
	ns (seasonal output)			%	201	194	205	200	184,0	182	181
Technical specifications											
Power supply	Voltage/Frequency/Phases		V/Hz/n°	230/50/1			230/50/1 - 400/50/3+N				
Water flow-rate	Water 35/30°C	Nominal	l/s	0,21	0,30	0,40	0,48	0,57	0,67	0,71	
Pump available pressure	Outdoor air 7°C	Nominal	kPa	89	87	80	71	63	54	49	
Minimum system water content				l	30		40				
Expansion tank capacity				l	8						
Sound power			Minimum / Nominal	dB(A)	51 / 56	53 / 58	55 / 60	56 / 61	58 / 65	59 / 65	60 / 69
Sound pressure @1m			Minimum / Nominal	dB(A)	40 / 44	42 / 46	42 / 48	43 / 49	43 / 51	44 / 52	48 / 56
Operating range											
Water supply temperature	Heating / DHW	Full electric	Minimum / Maximum	°C	25 / 75						
		Hybrid	Minimum / Maximum	°C	25 / 75						
Operating range (Outdoor air)	Cooling	-	Minimum / Maximum	°C	5 / 25						
		Heating	-	Minimum / Maximum	°C	-25 / 35					
Operating range (Outdoor air)	DHW	-	Minimum / Maximum	°C	-25 / 46						
		Cooling	-	Minimum / Maximum	°C	-5 / 46					

Data according to EN 14511:2022 and EN 14825:2022

The Product complies with the European ErP Directive (EU Regulations 811/2013 - 813/2013 - 2016/2281).

Dimensions and connections

Size			2.1	3.1	4.1	5.1	6.1 - 6.1T	7.1 - 7.1T	8.1 - 8.1T
Dimensions	AxCxB	mm	1.295x718x381				1.385x865x423		
Weight		kg	90		117		135 - 137		
		type / GWP			R-290 / 0.02				
Refrigerant charge		kg	0,70		1,10		1,25		
		CO ₂ tons	0,002		0,003				
External diameters	Water	inch	1"				1" 1/4		

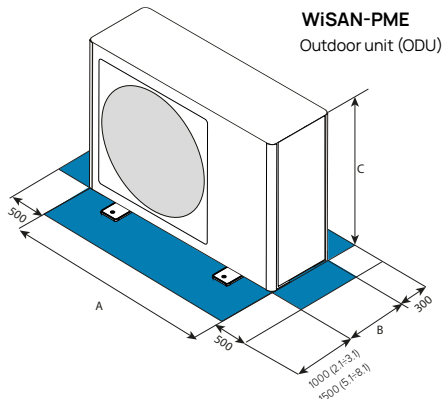

For trouble-free operation of the unit it is essential to maintain the safety distances indicated by the blue areas.

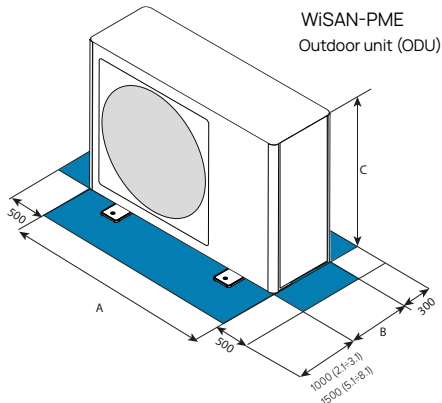

For trouble-free operation of the unit it is essential to maintain the safety distances indicated by the blue areas.

SIZES 2.1 to 3.1

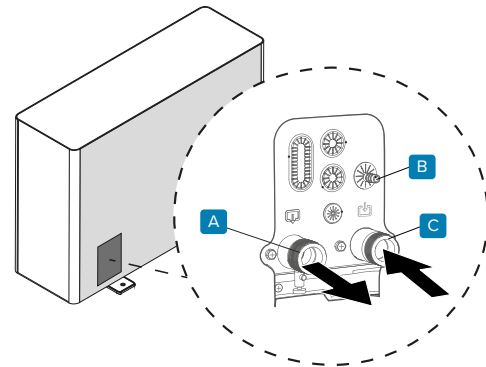

- 1 1" system supply
- 2 Safety valve Ø 16mm
- 3 1" system return

SIZES 4.1 to 8.1

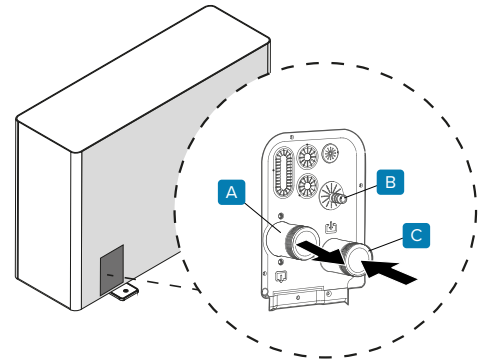

- 1 System supply 1 1/4"
- 2 Safety valve Ø 16mm
- 3 System return 1 1/4"

EDGE EVO 2.0 - EXC

Air-to-water packaged unit heat pump
for heating, cooling and domestic hot water production

Capacity from 4 to 30 kW



Energy saving

- Solar integration (DHW tank - optional)
- Cascade
- Smart Grid ready
- €-Switch

Comfort

- Hot Cold
- DHW
- Silent

Reliability

- Backup heater (optional)
- 041
- ProdottiQualità CasaClima

Health

- Renewable Energy (Full electric version)

Management and connectivity

- Input ON/ OFF
- User interface/ thermostat
- Port Modbus
- Control via App
- management CONTROL4 NRG
- Clivet Eye monitoring
- Energy metering

Convenience

- Weekley Timer
- Contemporaneity (Hybrid Version)
- Integrated DHW tank

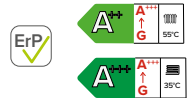

- ✓ Versatile: wide range of applications in both packaged and hydro-split versions
- ✓ Designed for harsh climates: excellent performance at low temperatures and optional 3 to 9 kW auxiliary heaters
- ✓ Simultaneous production of DHW and cooling/heating (Hybrid version)
- ✓ Modular: combines up to 6 units in cascade for capacities up to 180 kW
- ✓ Advanced connectivity: management via the dedicated App or via the Modbus port with CONTROL4 NRG standard supplied

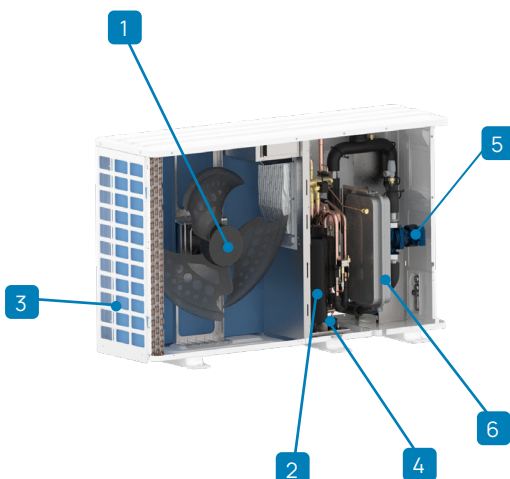

- 1 Inverter DC fan
- 2 Inverter DC twin-rotary compressor
- 3 Air-gas finned exchanger (blue fin treatment)
- 4 Gas/water plate exchanger
- 5 Inverter DC high efficiency pump
- 6 4.8-litre system expansion tank

Configurations





























BACK-UP ELECTRIC HEATER (INTEGRATED IN THE UNIT):

-	No heater (standard)	IBH	Electric back-up heater (only available for 2.1-8.1)
---	----------------------	-----	--

Mandatory accessories

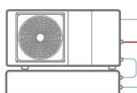
	HMIRNX	KJRH-120L2 nero Control		NEW KITR32X	Simplified installation kit for R-32 units
	HMIRBX	KJRH-120L2 bianco Control			

Accessories

	IBHX	Electric back-up heater (single phase)		VDACSX	Thermostat-controlled switching valve for domestic hot water
	IBHTX	Electric back-up heater (three-phase)		DI50-2X	50 liter hydraulic separator
	3DHWX	System/DHW 3-way switching valve (SV1)		DI100-2X	100-litre circuit breaker
	ACS200X	200 liter DHW tank		KCSX	Secondary circuit kit (1-litre hydraulic circuit breaker + pump)
	ACS300X	300 liter DHW tank		KIRE2HX	Double zone distribution unit: direct + direct
	ACS500X	500 liter DHW tank		KIRE2HLX	Double zone distribution unit: direct + mixed (with mixing valve)
	QERAX	Connection kit for single-phase heater on DHW storage tank (for ACS200/300/500X)		DTX	Condensate collection pan with electric heater
	SCS08X	Solar coil for ACS500X DHW tank		T1BX	DHW temperature probe and additional 10m heating source
	SCS12X	Solar coil for ACS200X/ACS300X DHW boilers		T1B30X	DHW temperature probe and additional 30m heating source
	FDMX	Magnetic dirt separator filter for water distribution systems		AMRX	Kit of antivibration mounts for floor installation
	NEW TANKSX	50 L system inertial storage tank		ASTFX	Kit of antivibration mounts for installation on wall brackets, inertial tank or tray
	NEW TANKMX	75 L system inertial storage tank		KSIPX	Kit with wall fixing brackets
	NEW TANKLX	100 L system inertial storage tank		HTC2WX	White HID-TConnect2 chronothermostat for temperature control
	KTCAX	Hose kit for connecting the unit to the inertial storage tank		SWCX	Receiver / IoT switch SwitchConnect
	VAGX	Safety antifreeze valve for system			

Technical data

Size				2.1	3.1	4.1	5.1	6.1 - 6.1T	7.1 - 7.1T	8.1 - 8.1T	
Heating	Capacity	Water 35/30 °C	Nominal / Maximum	kW	4,20 / 6,26	6,35 / 7,41	8,40 / 9,11	10,0 / 10,3	12,1 / 14,6	14,5 / 15,5	15,9 / 16,8
	COP	Outdoor air 7 °C	Nominal	-	5,10	4,95	5,15	4,95	4,95	4,60	4,50
	Capacity	Water 35/30 °C	Nominal / Maximum	kW	4,70 / 4,99	6,00 / 6,21	7,00 / 7,27	8,00 / 8,31	10,0 / 11,0	12,0 / 12,7	13,1 / 13,9
	COP	Outdoor air -7 °C	Nominal	-	3,10	3,00	3,20	3,05	3,00	2,85	2,70
Cooling	Capacity	Water 45/40 °C	Nominal / Maximum	kW	4,30 / 5,96	6,30 / 7,13	8,10 / 8,98	10,0 / 10,3	12,3 / 14,5	14,1 / 15,7	16,0 / 16,6
	COP	Outdoor air 7 °C	Nominal	-	3,80	3,70	3,85	3,75	3,70	3,60	3,50
	Capacity	Water 18/23 °C	Nominal / Maximum	kW	4,50 / 7,65	6,50 / 7,65	8,30 / 11,1	9,90 / 12,0	12,0 / 15,0	13,5 / 15,3	14,2 / 16,4
	EER	Outdoor air 35 °C	Nominal	-	5,50	4,80	5,05	4,55	3,95	3,61	3,61
Electrical power for meter sizing	Capacity	Water 7/12 °C	Nominal / Maximum	kW	4,70 / 6,14	7,00 / 7,11	7,45 / 7,94	8,20 / 8,67	11,5 / 11,5	12,4 / 12,4	14,0 / 14,0
	EER	Outdoor air 35 °C	Nominal	-	3,45	3,00	3,35	3,25	2,75	2,50	2,50
Seasonal efficiency Medium climate	Energy class			-	A++	A++	A++	A++	A++	A++	A++
	Heating Water 55 °C	Annual energy consumption		kWh/year	2.749	3.348	4.064	4.541	6.916	6.917	7.213
		SCOP		-	3,31	3,52	3,37	3,47	3,45	3,47	3,41
	ns (seasonal output)		%	129	138	131	137	135	135	133	
	Energy class			-	A+++	A+++	A+++	A+++	A+++	A+++	A+++
	Heating Water 35 °C	Annual energy consumption		kWh/year	2.354	2.849	3.223	3.649	5.156	5.157	6.011
		SCOP		-	4,85	4,95	5,22	5,20	4,81	4,72	4,62
	ns (seasonal output)		%	191	195	205	205	189	186	182	
Technical specifications											
Power supply	Voltage/Frequency/Phases		V/Hz/n°	230/50/1			230/50/1 - 400/50/3+N				
Water flow-rate	Water 35/30 °C	Nominal	l/s	0,20	0,30	0,40	0,48	0,58	0,69	0,76	
Pump available pressure	Outdoor air 7 °C	Nominal	kPa	85	84	80	71	60	48	40	
Minimum system water content				l	30	30	40	40	40	40	
Expansion tank capacity				l	4,8						
Sound power			Minimum / Nominal	dB(A)	53 / 55	55 / 58	54 / 59	55 / 60	59 / 65	59 / 65	59 / 68
Sound pressure @1m			Nominal	dB(A)	45	47	48	50	53	53	57
Operating range											
Water supply temperature	Heating / DHW	Full electric	Minimum / Maximum	°C	25 / 65						
		Hybrid	Minimum / Maximum	°C	25 / 75						
Operating range (Outdoor air)	Cooling	-	Minimum / Maximum	°C	5 / 25						
		Heating	-	Minimum / Maximum	°C	-25 / 35					
	DHW	-	Minimum / Maximum	°C	-25 / 43						
		Cooling	-	Minimum / Maximum	°C	-5 / 43					

Data according to EN 14511:2022 and EN 14825:2022

The Product complies with the European ErP Directive (EU Regulations 811/2013 - 813/2013 - 2016/2281).

Size				9.1	10.1	12.1	14.1	
Heating	Capacity	Water 35/30 °C	Nominal / Maximum	kW	18,0 / 20,9	22,0 / 24,1	26,0 / 27,9	30,1 / 30,11
	COP	Outdoor air 7 °C	Nominal	-	4,70	4,40	4,08	3,91
	Capacity	Water 35/30 °C	Nominal / Maximum	kW	18,0 / 21,1	21,0 / 21,8	22,0 / 22,0	23,0 / 23,0
	COP	Outdoor air -7 °C	Nominal	-	2,70	2,60	2,50	2,45
	Capacity	Water 45/40 °C	Nominal / Maximum	kW	18,0 / 20,3	22,0 / 23,2	26,0 / 27,1	30,0 / 31,0
	COP	Outdoor air 7 °C	Nominal	-	3,50	3,40	3,10	2,90
Cooling	Capacity	Water 18/23 °C	Nominal / Maximum	kW	18,5 / 22,7	23,0 / 28,4	27,0 / 30,1	31,0 / 35,2
	EER	Outdoor air 35 °C	Nominal	-	4,75	4,60	4,30	4,00
	Capacity	Water 7/12 °C	Nominal / Maximum	kW	17,0 / 18,1	21,0 / 22,4	26,0 / 27,3	29,5 / 29,5
	EER	Outdoor air 35 °C	Nominal	-	3,05	2,95	2,70	2,55
Electrical power for meter sizing				kW	10,6	12,5	13,8	14,5
Seasonal efficiency Medium climate	Energy class			-	A++	A++	A+	A+
	Heating Water 55 °C	Annual energy consumption		kWh/year	11.396	14.363	17.116	19.552
		SCOP		-	3,20	3,23	3,15	3,15
	ns (seasonal output)		%	125	125	123	123	
	Energy class			-	A+++	A+++	A+++	A++
	Heating Water 35 °C	Annual energy consumption		kWh/year	8.077	10.167	11.513	14.372
		SCOP		-	4,60	4,53	4,50	4,20
	ns (seasonal output)		%	181	179	177	165	
Technical specifications								
Power supply		Voltage/Frequency/Phases		V/Hz/n°	400/50/3+N			
Water flow-rate		Water 35/30 °C	Nominal	l/s	0,86	1,05	1,24	1,44
Pump available pressure		Outdoor air 7 °C	Nominal	kPa	100	92	80	59
Minimum system water content				l	100			
Expansion tank capacity				l	4,8			
Sound power			Minimum / Nominal	dB(A)	64 / 71	63 / 73	71 / 75	73 / 77
Sound pressure @1m			Nominal	dB(A)	58	60	61	63
Operating range								
Water supply temperature	Heating / DHW	Full electric	Minimum / Maximum	°C	25 / 60			
		Hybrid	Minimum / Maximum	°C	25 / 70			
Operating Voltage Range	Heating	-	Minimum / Maximum	°C	5 / 25			
		-	Minimum / Maximum	°C	-25 / 35			
Outdoor air	Cooling	-	Minimum / Maximum	°C	-25 / 43			
		-	Minimum / Maximum	°C	-5 / 46			

Data according to EN 14511:2022 and EN 14825:2022
 The Product complies with the European ErP Directive (EU Regulations 811/2013 - 813/2013 - 2016/2281).

Dimensions and connections

Size			2.1	3.1	4.1	5.1	6.1 - 6.1T	7.1 - 7.1T	8.1 - 8.1T
Dimensions	AxCxB	mm	1.295x714x400				1.385x864x445		
Weight		kg	86		105		129 - 144		
Refrigerant charge		type / GWP	R-32 / 675						
		kg			1,40		1,75		
		CO ₂ tons			0,95		1,18		
External diameters	Water	inch	1"				1" 1/4		

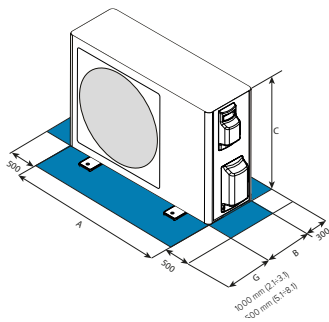

WiSAN-YME
Outdoor unit (ODU)

For trouble-free operation of the unit it is essential to maintain the safety distances indicated by the blue areas.

SIZES 2.1 to 3.1

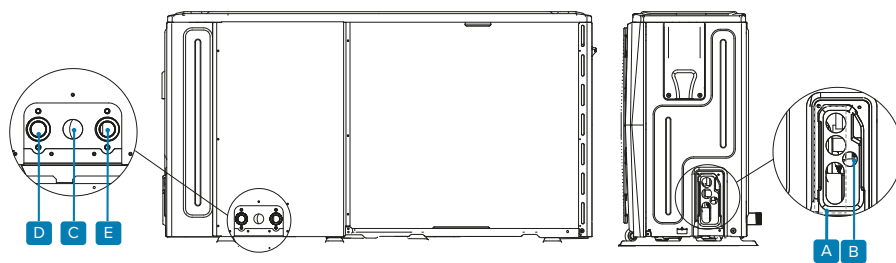

SIZES 4.1 to 8.1

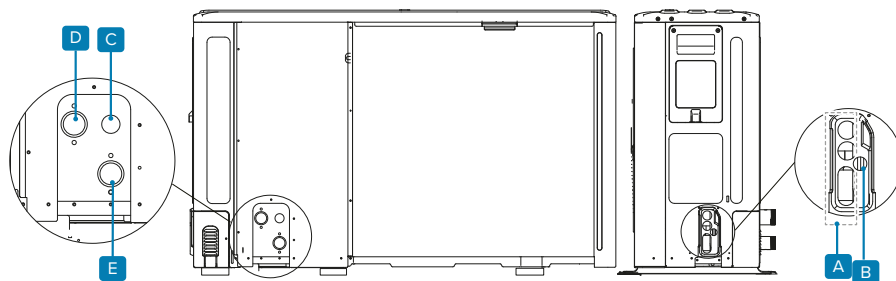

- T0** Hole for high voltage cable (power supply)
- B** Hole for low pressure cable (control and signal cables)
- C** Hole for discharge pipe
- D** Water outlet
- E** Water inlet

Size			9.1	10.1	12.1	14.1
Dimensions	AxCxB	mm	1120x1.557x444			
Weight		kg	177			
Refrigerant charge		type / GWP	R-32 / 675			
		kg	5,00			
		CO ₂ tons	3,38			
External diameters	Water	inch	1" 1/4			

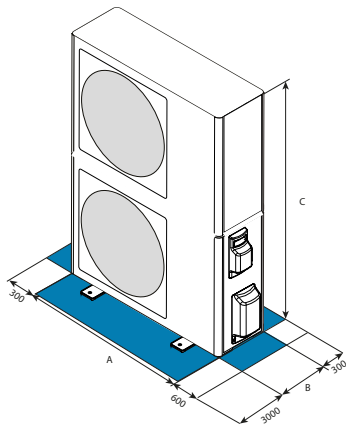

WiSAN-YME
Outdoor unit (ODU)

For trouble-free operation of the unit it is essential to maintain the safety distances indicated by the blue areas.

SIZES 9.1 to 14.1

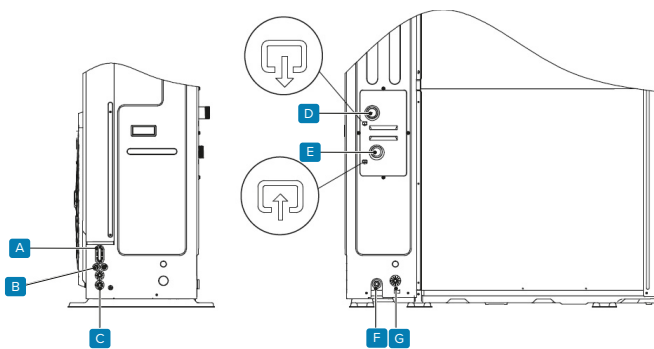

- A** Hole for high voltage cable (power supply)
- B** Hole for low pressure cable (control and signal cables)
- C** Hole for discharge pipe
- D** Water outlet
- E** Water inlet
- F** Hole for discharge pipe
- G** Hole for safety valve drain pipe

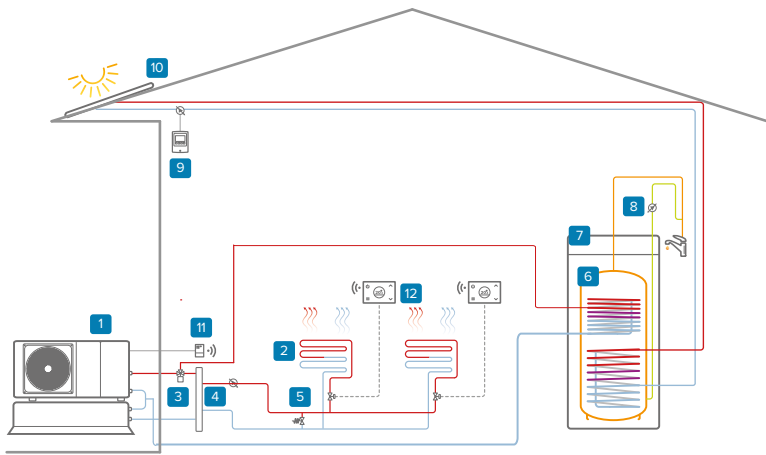

Full electric single-area system with thermal solar:

Heating / Cooling / DHW

- 1 Outdoor unit
- 2 heating/cooling zone
- 3 3-way diverting valve (optional)
- 4 Single-zone header + pump kit
- 5 Bypass*
- 6 DHW boiler with solar coil (optional) boiler connection kit (optional)
- 7 DHW circulation pump (optional)
- 8 Solar circulation kit (optional)
- 9 ELFOSUN3 thermal solar (optional)
- 10 SwitchConnect Wi-Fi receiver (optional)
- 11 HID-TConnect2 Wi-Fi chronothermostat (optional)
- 12 (optional)

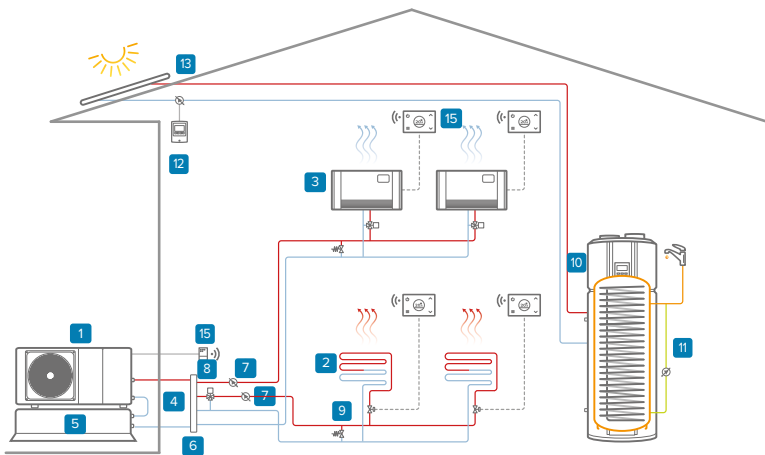

Full electric two-area system with thermal solar:

Heating / Cooling / DHW

- 1 Outdoor unit
- 2 Heating area
- 3 Cooling area
- 4 Buffer tank connection kit (optional)
- 5 System inertial storage (optional)
- 6 Hydraulic separator (optional)
- 7 Secondary circuit pump (optional)
- 8 3-way mixing valve*
- 9 Bypass*
- 10 Heat pump for DHW
- 11 DHW circulation pump (optional)
- 12 Solar circulation kit (optional)
- 13 ELFOSun3 thermal solar (optional)
- 14 SwitchConnect Wi-Fi receiver (optional)
- 15 HID-TConnect2 Wi-Fi chronothermostat (optional)

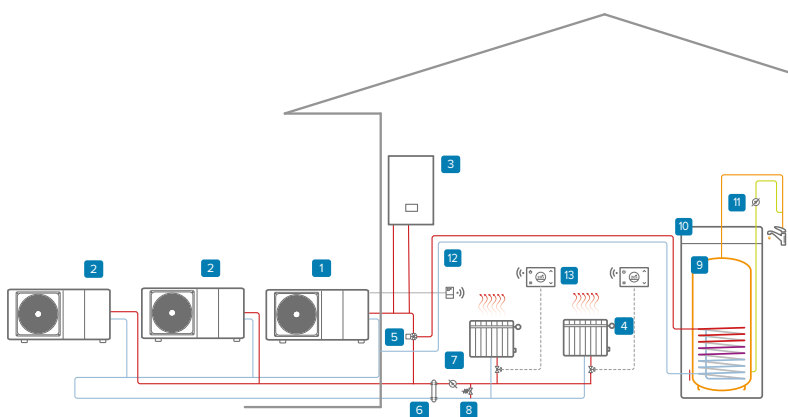

Hybrid single-zone system in cascade:

Heating / Cooling / DHW

- 1 Indoor unit (Master)
- 2 Outdoor unit (Slave)
- 3 instantaneous boiler (Hybrid version)
- 4 Heating area
- 5 3-way diverting valve (optional)
- 6 Hydraulic separator (optional)
- 7 Secondary circuit pump (optional)
- 8 Bypass*
- 9 DHW tank (optional)
- 10 DHW tank connection kit (optional)
- 11 DHW circulation pump (optional)
- 12 SwitchConnect Wi-Fi receiver (optional)
- 13 HID-TConnect2 Wi-Fi chronothermostat (optional)

The diagrams are for illustrative purposes only, showing possible combinations of system elements.

*from external supply

HYDRO-SPLIT

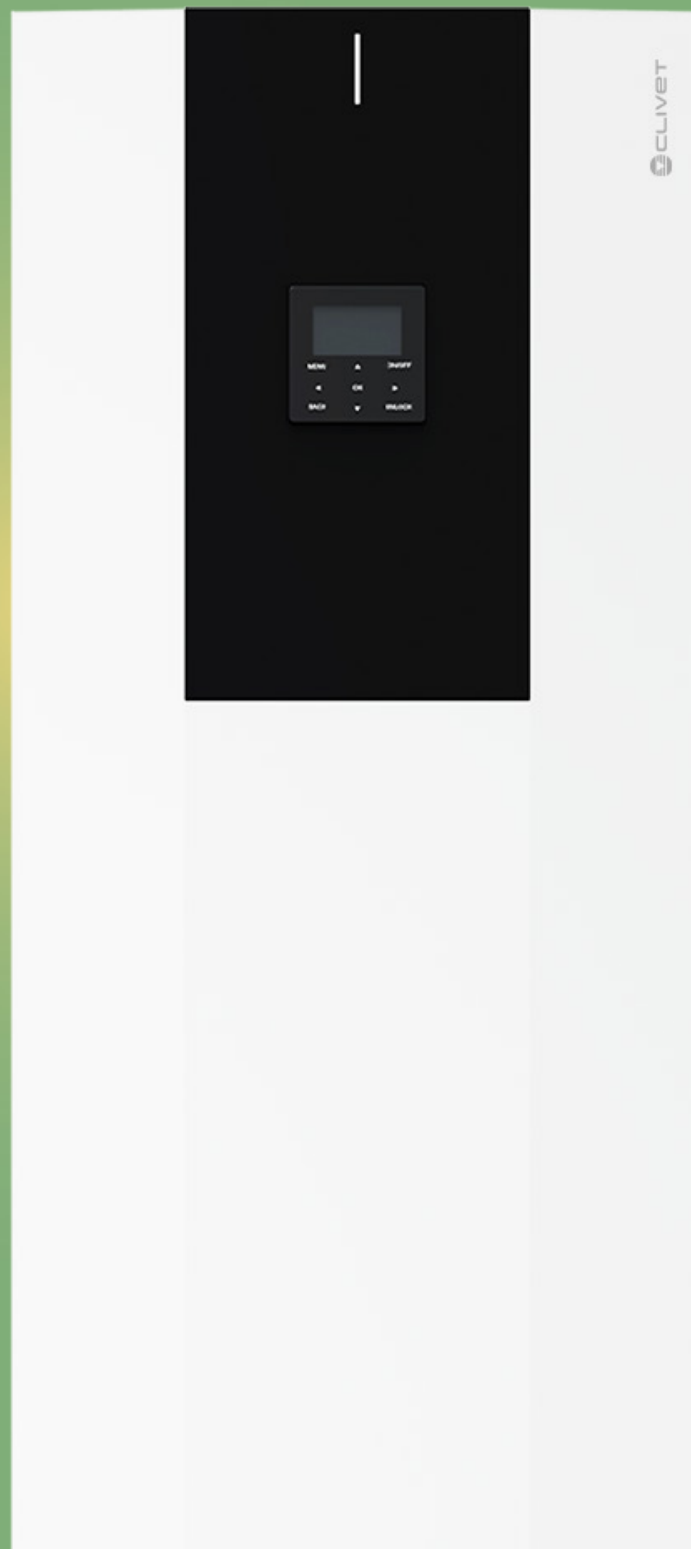

2.1 Heat pumps

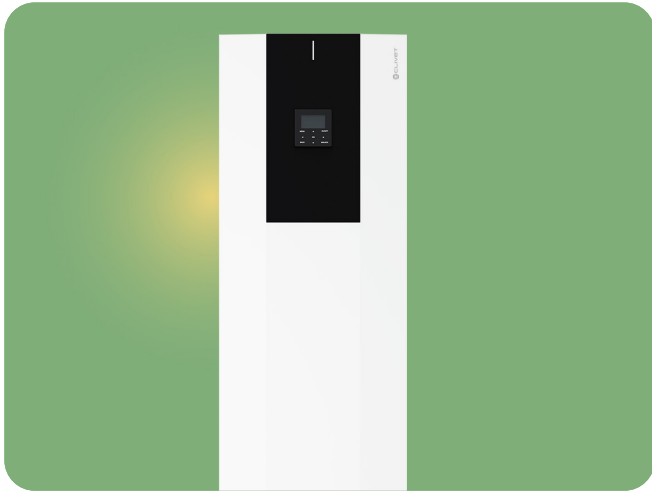

Hydro-Split - TOWER VERSION



Hydro-Split - BOX VERSION



Hydro-Split - INVISIBLE VERSION



Hydro-Split - MINI VERSION

HYDRO-SPLIT TOWER

Indoor hydronic unit with base with DHW tank for Hydro Split systems



HEAT PUMPS

Energy saving



Solar integration (DHW tank - optional)



Cascade



€-Switch

Comfort



Hot Cold



DHW



Silent

Convenience



Weekley Timer



Instant DHW (Hybrid Version)



Contemporaneity (Hybrid Version)



Integrated DHW tank

Management and connectivity



Input ON/OFF



Port Modbus



Control via the App



CONTROL4 NRG management



User interface / thermostat



Clivet Eye monitoring

Reliability



Backup heater (optional)

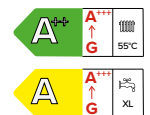

- ✓ 190 or 250 l ACS storage tank
- ✓ Wide range of integrable accessories
- ✓ Can be combined with EDGE outdoor units
- ✓ Reduced space requirements
- ✓ Easy installation

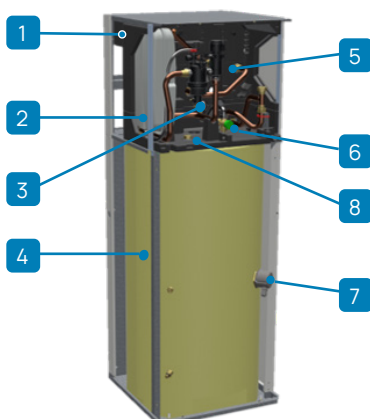

- 1 15-litre inertial tank
- 2 12-litre system expansion tank
- 3 Magnetic dirt separator filter+pressure relief valve
- 4 Domestic hot water storage tank
- 5 3-way valve for DHW
- 6 Thermostatic anti-scald valve
- 7 Backup electric heater
- 8 Electronic anode

Versatile to suit every type of system

Hydronic TOWER version modules are designed to be combined with the EDGE family of packaged heat pumps.

In addition to the DHW tank, they contain a 15-litre buffer tank, magnetic baffle filter, system expansion tank and anti-burn valve as standard.



Configurations

CONTROL:

- HMIR32 Can be combined with EDGE EVO 2.0
- HMIR290 Can be combined with EDGE F and EDGE PRO









DHW STORAGE TANK:

- ACS190 190 liter DHW tank
- ACS250 250 liter DHW tank

Hybrid version in combination with Clivet FE boiler

HEAT PUMPS

Interior accessories

	EH246X	Additional electric heater adjustable to three capacities of 2, 4 or 6 kW		SOLX	DHW plate exchanger kit for solar thermal connection
	EH9X	Additional electric heater adjustable to one capacity of 9 kW		SICGX	Intermediate exchanger for clean separation between primary and secondary circuit
	KCSIX	Secondary circuit kit (1L hydraulic circuit breaker + pump)		KTCTX	Top outlet connection piping kit Compatible only with standard version
	KIR2HX	Hydraulic kit for managing two areas with the same temperature		KTCSX	Left outlet connection piping kit Compatible only with standard version Not compatible with KTCSTX option
	KIR2HLX	Hydraulic kit for managing two areas with high and mixed temperature		KTCRX	Right outlet connection piping kit Compatible only with standard version
				KTCSTX	Solar circuit top connection kit Compatible only in the presence of option SOLX, not compatible with KTCSX.

External accessories

	ACI40X	System inertial tank 40 litres		VEACSX	Sanitary expansion tank
	COFX	Aesthetic cover for inertial storage tank		KCAIAX	Additional inertial tank connection kit

Technical data - TOWER version + EDGE EVO 2.0

HEAT PUMPS

Size - Set				2.1		3.1		4.1		5.1		6.1 - 6.1T	7.1 - 7.1T	8.1 - 8.1T					
DHW tank				190L	250L	190L	250L	190L	250L	190L	250L	250L	250L	250L					
Heating	Capacity	Water 35/30°C	Nominal / Maximum	kW 4,20 / 6,26		6,35 / 7,41		8,40 / 9,11		10,0 / 10,3		12,1 / 14,6		14,5 / 15,5		15,9 / 16,8			
	COP	Outdoor air 7°C	Nominal	5,10		4,95		5,15		4,95		4,95		4,60		4,50			
	Capacity	Water 35/30°C	Nominal / Maximum	kW 4,70 / 4,99		6,00 / 6,21		7,00 / 7,27		8,00 / 8,31		10,0 / 11,0		12,0 / 12,7		13,1 / 13,9			
	COP	Outdoor air -7°C	Nominal	-		3,10		3,00		3,20		3,05		3,00		2,85		2,70	
	Capacity	Water 45/40°C	Nominal / Maximum	kW 4,30 / 5,96		6,30 / 7,13		8,10 / 8,98		10,0 / 10,3		12,3 / 14,5		14,1 / 15,7		16,0 / 16,6			
	COP	Outdoor air 7°C	Nominal	-		3,80		3,70		3,85		3,75		3,70		3,60		3,50	
Cooling	Capacity	Water 18/23°C	Nominal / Maximum	kW 4,50 / 7,65		6,50 / 7,65		8,30 / 11,1		9,90 / 12,0		12,0 / 15,0		13,5 / 15,3		14,2 / 16,4			
	EER	Outdoor air 35°C	Nominal	-		5,50		4,80		5,05		4,55		3,95		3,61		3,61	
	Capacity	Water 7/12°C	Nominal / Maximum	kW 4,70 / 6,14		7,00 / 7,11		7,45 / 7,94		8,20 / 8,67		11,5 / 11,5		12,4 / 12,4		14,0 / 14,0			
	EER	Outdoor air 35°C	Nominal	-		3,45		3,00		3,35		3,25		2,75		2,50		2,50	
DHW	Net tank capacity		l	190	250	190	250	190	250	190	250	250	250	250					
	Water mixed at 40°C (V40) ¹		l	204	269	204	269	204	269	204	269	269	269	269					
	Heating time		h:min	2:30	2:25	2:30	2:25	2:08	2:05	2:08	2:05	1:46	1:46	1:46					
Electrical power for meter sizing				kW		2,30		2,70		3,40		3,70		5,50		6,20			
Seasonal efficiency Medium climate	Heating Water 55°C	Energy class	-	A++		A++		A++		A++		A++		A++		A++			
		Annual energy consumption	-	2,749		3,348		4,064		4,541		6,916		6,917		7,213			
		SCOP	-	3,31		3,52		3,37		3,47		3,45		3,47		3,41			
		ns (seasonal output)	%	129		138		131		137		135		135		133			
	Heating Water 35°C	Energy class	-	A+++		A+++		A+++		A+++		A+++		A+++		A+++			
		Annual energy consumption	-	2,354		2,849		3,223		3,649		5,156		5,157		6,011			
		SCOP	-	4,85		4,95		5,22		5,20		4,81		4,72		4,62			
		ns (seasonal output)	%	191		195		205		205		189		186		182			
	DHW	Energy class	-	A+	A+	A+	A+	A+	A+	A+	A+	A+	A+	A+					
		Withdrawal profile	-	L	XL	L	XL	L	XL	L	XL	L	XL	L	XL				
Size - Indoor unit				A	A	A	A	A	A	A	A	A	A						
Power supply	Voltage/Frequency/Phases			V/Hz/n°		220-240/50/1													
Expansion tank capacity				l		12													
Sound power				dB(A)		41													
Sound pressure @1m				dB(A)		26													
Size - Outdoor unit				2.1		3.1		4.1		5.1		6.1 - 6.1T	7.1 - 7.1T	8.1 - 8.1T					
Power supply	Voltage/Frequency/Phases			V/Hz/n°		220-240/50/1						220-240/50/1 - 380-415/50/3+N							
Water flow-rate	Water 35/30°C	Nominal	l/s	0,20		0,30		0,40		0,48		0,58		0,69		0,76			
Pump available pressure	Outdoor air 7°C	Nominal	kPa	85		84		80		71		60		48		40			
Expansion tank capacity				l		4,8													
Minimum system water content				l		30													
Sound power		Minimum / Nominal	dB(A)	53 / 55		55 / 58		54 / 59		55 / 60		59 / 65		59 / 65		59 / 68			
Sound pressure @1m		Nominal	dB(A)	45		47		48		50		53		53		57			
Operating range																			
Water supply temperature	Heating / DHW	Full electric	Minimum / Maximum	°C		25 / 65													
		Hybrid	Minimum / Maximum	°C		25 / 75													
	Cooling	-	Minimum / Maximum	°C		5 / 25													
Operating Voltage Range	Heating	-	Minimum / Maximum	°C		-25 / 35													
		DHW	-	Minimum / Maximum	°C		-25 / 43												
	Cooling	-	Minimum / Maximum	°C		-5 / 43													

Dimensions and connections

Size				2.1		3.1		4.1		5.1		6.1 - 6.1T	7.1 - 7.1T	8.1 - 8.1T	
Dimensions	Indoor unit ACS190	AxCxB	mm	600x1.694x615		600x1.694x615		600x1.694x615		600x1.694x615		-	-	-	
	Indoor unit ACS250	AxCxB	mm	600x2.004x615		600x2.004x615		600x2.004x615		600x2.004x615		600x2.004x615		600x2.004x615	
	Outdoor unit	AxCxB	mm	1.295x717x400		1.295x717x400		1.385x864x445		1.385x864x445		1.385x864x445		1.385x864x445	
Operating weight	Indoor unit ACS190		kg	359		359		359		359		-	-	-	
	Indoor unit ACS250		kg	419		419		419		419		421		421	
	Outdoor unit		kg	86		86		105		105		129 / 144		129 / 144	
Refrigerant charge			type / GWP	R-32 / 675		R-32 / 675		R-32 / 675		R-32 / 675		R-32 / 675		R-32 / 675	
			kg	1,40		1,40		1,40		1,40		1,75		1,75	
			CO ₂ tons	0,95		0,95		0,95		0,95		1,18		1,18	
External diameters	Indoor unit	Water (System)	inch	1"		1"		1"		1"		1"		1"	
		Water (DHW)	inch	1/2"		1/2"		1/2"		1/2"		1/2"		1/2"	
	Outdoor unit	Water (System)	inch	1"		1"		1" 1/4		1" 1/4		1" 1/4		1" 1/4	

The letter M next to the value identifies the supply voltage 220-240/50/1, and the letter T identifies the supply voltage 380-415/50/3+N.

Connection detail

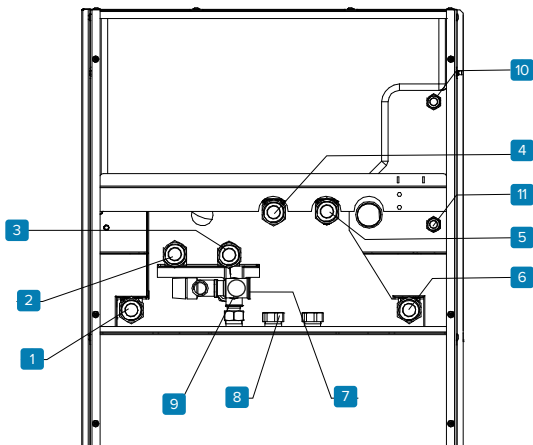

- 1 Water supply from outdoor unit 1"
- 2 Area 2 system return - 1" (optional)
- 3 Area 2 system supply - 1" (optional)
- 4 Area 1 system return - 1"
- 5 Area 1 system return - 1"
- 6 Water return to outdoor unit 1"
- 7 Water supply system inlet 1/2"
- 8 DHW recirculation 3/4"
- 9 DHW outlet 1/2"
- 10 Supply to solar system 3/4" (optional)
- 11 Return from solar system 3/4" (optional)

SIZES 2.1 to 3.1

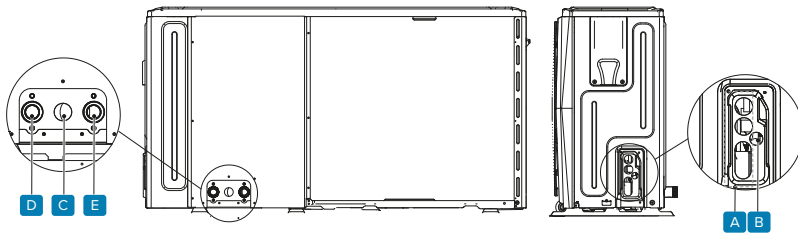

SIZES 4.1 to 8.1

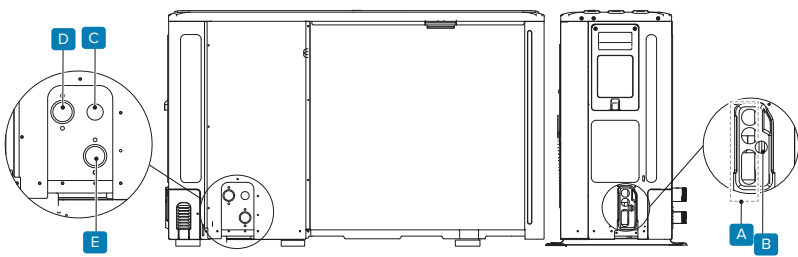

- 1 Hole for high voltage cable (power supply)
- 2 Hole for low pressure cable (control and signal cables)
- 3 Hole for discharge pipe
- 4 Water outlet
- 5 Water inlet

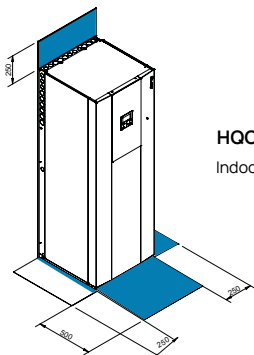

HQCN-NEE 1 TC A
Indoor unit (IDU)

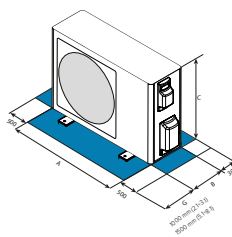

WiSAN-YME 1 S
Outdoor unit (ODU)

For trouble-free operation of the unit it is essential to maintain the safety distances indicated by the blue areas.

Technical data - TOWER version + EDGE F

Size - Set			2.1		3.1		4.1		5.1		6.1 - 6.1T		7.1 - 7.1T		8.1 - 8.1T																	
DHW tank			190L	250L	190L	250L	190L	250L	190L	250L	250L		250L		250L																	
Heating	Capacity	Water 35/30°C	Nominal / Maximum	kW		4,50 / 6,86	6,20 / 7,70	8,40 / 10,4	10,0 / 11,0	12,0 / 14,7	14,0 / 16,0	15,0 / 17,6																				
	COP	Outdoor air 7°C	Nominal	-		5,15	4,90	5,00	4,70	4,80	4,50	4,40																				
	Capacity	Water 35/30°C	Nominal / Maximum	kW		4,50 / 5,56	5,90 / 6,18	7,00 / 8,74	8,00 / 8,89	10,0 / 11,1	11,5 / 12,1	12,7 / 13,2																				
	COP	Outdoor air -7°C	Nominal	-		3,10	2,95	3,00	2,85	2,80	2,70	2,50																				
	Capacity	Water 45/40°C	Nominal / Maximum	kW		4,50 / 6,55	6,40 / 7,35	8,20 / 9,57	10,0 / 10,5	12,0 / 14,1	14,0 / 15,3	15,0 / 16,9																				
	COP	Outdoor air 7°C	Nominal	-		4,05	3,80	3,85	3,65	3,70	3,50	3,35																				
	Capacity	Water 18/23°C	Nominal / Maximum	kW		4,50 / 7,84	6,50 / 9,75	8,30 / 11,4	10,0 / 12,1	12,0 / 16,4	14,0 / 17,3	16,0 / 18,6																				
	EER	Outdoor air 35°C	Nominal	-		5,50	5,10	5,15	4,75	4,50	4,20	3,90																				
Cooling	Capacity	Water 7/12°C	Nominal / Maximum	kW		4,70 / 5,66	6,80 / 7,14	7,50 / 8,19	8,76 / 8,76	11,5 / 12,0	12,7 / 12,7	14,0 / 14,3																				
	EER	Outdoor air 35°C	Nominal	-		3,65	3,10	3,45	3,01	3,05	2,90	2,75																				
	Net tank capacity			l	190	250	190	250	190	250	190	250	190	250	190	250																
	Water mixed at 40°C (V40)			l	204	269	204	269	204	269	204	269	204	269	204	269																
Heating time			h:min	02:30	02:25	02:30	02:25	02:08	02:05	2:08	2:05	01:48	01:46	01:48	01:46																	
Electrical power for meter sizing			kW		2,70	3,00	3,60	3,90	5,70	6,00	6,40																					
Seasonal efficiency Medium climate	Heating Water 55°C	Energy class	-	A++		A++		A++		A++		A++		A++																		
		Annual energy consumption	-	2.684		3.164		3.676		4.215		6.847		8.349																		
		SCOP	-	3,79		3,81		3,81		3,82		3,62		3,57																		
		ns (seasonal output)	%	148		150		150		150		142		140																		
		Energy class	-	A+++		A+++		A+++		A+++		A+++		A+++																		
		Annual energy consumption	-	2.040		2.692		3.187		3.734		5.376		6.091		6.630																
	Heating Water 35°C	SCOP	-	5,09		4,91		5,20		5,07		4,68		4,64		4,59																
		ns (seasonal output)	%	201		194		205		200		184		182		181																
		Energy class	-	A+		A+		A+		A+		A+		A+		A+																
	DHW	Withdrawal profile		-	L	XL	L	XL	L	XL	L	XL	XL	XL	XL	XL																
		Withdrawal profile		-	A		A		A		A		A		A																	
	Size - Indoor unit																															
Power supply			Voltage/Frequency/Phases			V/Hz/n°			220-240/50/1																							
Expansion tank capacity			l			12																										
Sound power			dB(A)			41																										
Sound pressure @1m			dB(A)			26																										
Size - Outdoor unit			2.1			3.1			4.1			5.1			6.1 - 6.1T			7.1 - 7.1T			8.1 - 8.1T											
Power supply			Voltage/Frequency/Phases			V/Hz/n°			220-240/50/1			220-240/50/1 - 380-415/50/3+N																				
Water flow-rate			Water 35/30°C			Nominal			l/s			0,21			0,30			0,40			0,48			0,57			0,67			0,71		
Pump available pressure			Outdoor air 7°C			Nominal			kPa			89			87			80			71			63			54			49		
Expansion tank capacity			l			8																										
Minimum system water content			l			30			40																							
Sound power			Minimum / Nominal			dB(A)			51 / 56			53 / 58			55 / 60			56 / 61			58 / 65			59 / 65			60 / 69					
Sound pressure @1m			Minimum / Nominal			dB(A)			40 / 44			42 / 46			42 / 48			43 / 49			43 / 51			44 / 52			48 / 56					
Operating range																																
Water supply temperature	Heating / DHW	Full electric	Minimum / Maximum			°C			25 / 75																							
		Hybrid	Minimum / Maximum			°C			25 / 75																							
	Cooling	-	Minimum / Maximum			°C			5 / 25																							
Operating Voltage Range	Heating	-	Minimum / Maximum			°C			-25 / 35																							
	DHW	-	Minimum / Maximum			°C			-25 / 43																							
Outdoor air			Cooling	-	Minimum / Maximum			°C			-5 / 43																					

Dimensions and connections

Size			2.1		3.1		4.1		5.1		6.1 - 6.1T		7.1 - 7.1T		8.1 - 8.1T		
Dimensions	Indoor unit ACS190	AxCxB	mm		600x1.694x615		600x1.694x615		600x1.694x615		600x1.694x615		-		-		
	Indoor unit ACS250	AxCxB	mm		600x2.004x615		600x2.004x615		600x2.004x615		600x2.004x615		600x2.004x615		600x2.004x615		
	Outdoor unit	AxCxB	mm		1.295x718x386		1.295x718x386		1.385x865x423		1.385x865x423		1.385x865x423		1.385x865x423		
Operating weight	Indoor unit ACS190		kg		359		359		359		-		-		-		
	Indoor unit ACS250		kg		419		419		419		421		421		421		
	Outdoor unit		kg		90		90		117		117		135		135		
Refrigerant charge				tipo/GWP		R-290 / 0.02		R-290 / 0.02		R-290 / 0.02		R-290 / 0.02		R-290 / 0.02		R-290 / 0.02	
				kg		0,70		0,70		1,10		1,10		1,25		1,25	
				CO2 tons		0,002		0,002		0,003		0,003		0,004		0,004	
External diameters	Indoor unit	Water (System)	inch		1"		1"		1"		1"		1"		1"		
		Water (DHW)	inch		1/2"		1/2"		1/2"		1/2"		1/2"		1/2"		
	Outdoor unit	Water (System)	inch		1"		1"		1" 1/4		1" 1/4		1" 1/4		1" 1/4		

Connection detail

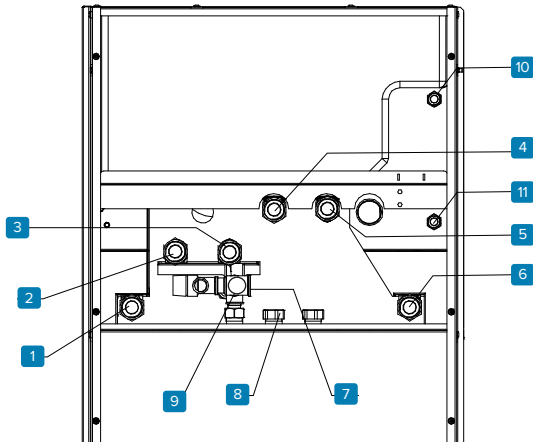

- 1 Water supply from outdoor unit 1"
- 2 Area 2 system return - 1" (optional)
- 3 Area 2 system supply - 1" (optional)
- 4 Area 1 system return - 1"
- 5 Area 1 system return - 1"
- 6 Water return to outdoor unit 1"
- 7 Water supply system inlet 1/2"
- 8 DHW recirculation 3/4"
- 9 DHW outlet 1/2"
- 10 Supply to solar system 3/4" (optional)
- 11 Return from solar system 3/4" (optional)

SIZES 2.1 to 3.1

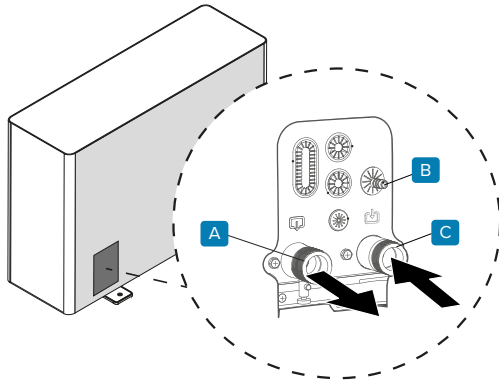

- A 1" system supply
- B Pressure relief valve Ø 16 mm
- C 1" system return

SIZES 4.1 to 8.1

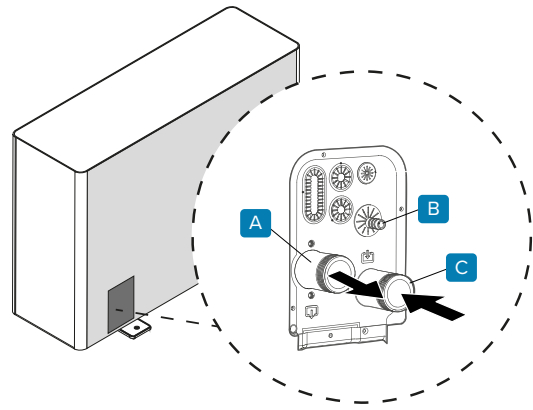

- A System supply 1 1/4"
- B Pressure relief valve Ø 16 mm
- C System return 1 1/4"

HEAT PUMPS

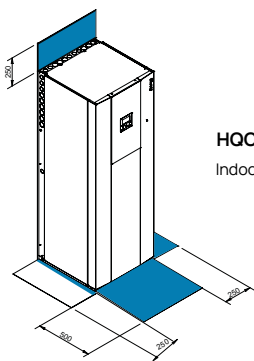

HQCN-NEE 1 TC A
Indoor unit (IDU)

WiSAN-PME 1 S
Outdoor unit (ODU)

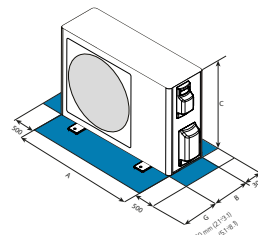

- E = 500 mm
- F = 500 mm
- G = 1000 mm (2.1÷3.1)
- H = 300 mm

For trouble-free operation of the unit it is essential to maintain the safety distances indicated by the blue areas.

Technical data - TOWER versione + EDGE PRO

Size - Set				2.1		3.1		4.1		5.1		6.1 - 6.1T		7.1 - 7.1T		8.1 - 8.1T					
DHW tank				190L	250L	190L	250L	190L	250L	190L	250L	250L		250L		250L					
Heating	Capacity	Water 35/30°C	Nominal / Maximum	kW				4,10 / 7,72		6,10 / 8,99		8,00 / 11,6		9,50 / 12,6		12,1 / 15,0		14,0 / 16,3		15,5 / 17,7	
	COP	Outdoor air 7°C	Nominal	-				5,30		5,03		5,25		4,95		4,95		4,70		4,50	
	Capacity	Water 35/30°C	Nominal / Maximum	kW				4,10 / 6,70		6,00 / 7,63		7,00 / 9,12		8,00 / 9,64		10,0 / 12,4		12,0 / 14,6		13,1 / 15,7	
	COP	Outdoor air -7°C	Nominal	-				3,25		3,03		3,25		3,15		3,15		2,80		2,70	
	Capacity	Water 45/40°C	Nominal / Maximum	kW				4,50 / 7,27		6,40 / 8,51		8,10 / 11,0		9,50 / 12,2		12,3 / 14,5		14,1 / 16,0		15,5 / 17,3	
	COP	Outdoor air 7°C	Nominal	-				4,17		3,91		4,00		3,90		3,90		3,75		3,65	
Cooling	Capacity	Water18/23°C	Nominal / Maximum	kW				4,50 / 8,36		6,50 / 10,8		8,30 / 11,0		10,0 / 11,9		12,0 / 17,1		14,0 / 18,2		16,0 / 18,9	
	EER	Outdoor air 35°C	Nominal	-				5,65		5,51		5,25		4,60		4,60		4,40		4,25	
	Capacity	Water 7/12°C	Nominal / Maximum	kW				4,70 / 6,96		6,80 / 9,03		7,50 / 9,19		8,10 / 9,90		11,5 / 13,9		12,4 / 14,9		14,0 / 16,7	
	EER	Outdoor air 35°C	Nominal	-				3,65		3,10		3,35		3,10		3,05		3,00		2,70	
DHW	Net tank capacity			l		190 250		190 250		190 250		190 250		190 250		190 250		190 250			
	Water mixed at 40°C (V40)			l		204 269		204 269		204 269		204 269		204 269		204 269		204 269			
	Heating time			h:min		02:30 02:25		02:30 02:25		02:08 02:05		02:08 02:05		01:48 01:46		01:48 01:46		01:48 01:46			
Electrical power for meter sizing				kW		2,70		3,00		3,90		4,20		5,90		6,30		6,70			
Seasonal efficiency Medium climate	Energy class			-				A+++		A+++		A+++		A+++		A+++		A+++			
	Heating	Annual energy consumption			-				2,647		3,120		4,056		5,145		6,266		7,479		
		SCOP			-				3,91		3,98		4,08		4,02		3,96		3,87		
		ns (seasonal output)			%				153		156		160		158		155		152		
	Energy class			-				A+++		A+++		A+++		A+++		A+++		A+++			
	Heating	Annual energy consumption			-				1,984		2,460		3,095		3,889		5,014		6,069		
		SCOP			-				5,10		5,00		5,35		5,33		4,94		4,76		
		ns (seasonal output)			%				206		199		211		210		195		188		
	DHW			Energy class			-				A+ A+		A+ A+		A+ A+		A+ A+		A+ A+		
	DHW			Withdrawal profile			-				L XL		L XL		L XL		L XL		L XL		
	Size - Indoor unit				A																
Power supply				Voltage/Frequency/Phases			V/Hz/n°														
Expansion tank capacity				l			12 12 12 12 12 12 12 12 12 12 12 12 12 12 12 12 12 12														
Sound power				dB(A)			41 41 41 41 41 41 41 41 41 41 41 41 41 41 41 41 41 41														
Sound pressure @1m				dB(A)			26 26 26 26 26 26 26 26 26 26 26 26 26 26 26 26 26 26														
Size - Outdoor unit				2.1 3.1 4.1 5.1 6.1 - 6.1T 7.1 - 7.1T 8.1 - 8.1T																	
Power supply				Voltage/Frequency/Phases			V/Hz/n°														
Water flow-rate				Water 35/30°C			l/s														
Pump available pressure				Outdoor air 7°C			Nominal														
Minimum system water content				l			40 40 40 40 40 40 40 40 40 40 40 40 40 40 40 40 40 40														
Sound power				Minimum / Nominal			dB(A)														
Sound pressure @1m				Minimum / Nominal			dB(A)														
Operating range																					
Water supply temperature	Heating / DHW	Full electric		Minimum / Maximum			°C														
		Hybrid		Minimum / Maximum			°C														
		-		Minimum / Maximum			°C														
Operating Voltage Range	Heating		-			°C															
	DHW		-			°C															
Outdoor air		Cooling		-			°C														

Dimensions and connections

Size				2.1		3.1		4.1		5.1		6.1 - 6.1T		7.1 - 7.1T		8.1 - 8.1T			
Dimensions	Indoor unit ACS190	AxCxB	mm	600x1.700x612															
	Indoor unit ACS250	AxCxB	mm	600x2.010x615						1.330x1.051x528									
	Outdoor unit	AxCxB	mm																
Operating weight	Indoor unit ACS190		kg	357															
	Indoor unit ACS250		kg	417															
	Outdoor unit		kg	150				155 - 160				175 - 180							
Refrigerant charge				tipo/GWP				R-290 / 0.02											
				kg				0,70				1,10				1,25			
				CO2 tons				0,002								0,00003			
External diameters	Indoor unit	Water (System)		inch			1"												
		Water (DHW)		inch			1/2"												
		Water (System)		inch			1" 1/4												

HEAT PUMPS

Connection detail

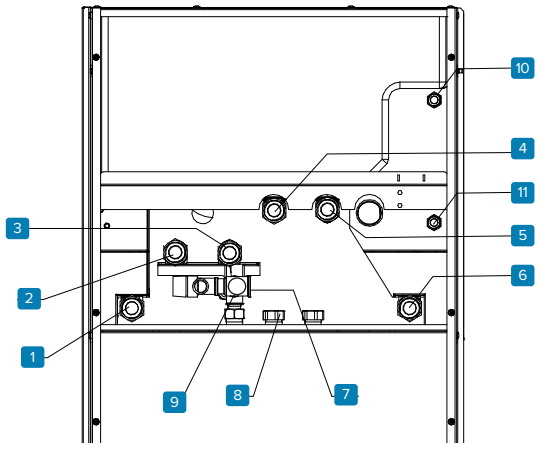

- 1 Water supply from outdoor unit 1"
- 2 Area 2 system return - 1" (optional)
- 3 Area 2 system supply - 1" (optional)
- 4 Area 1 system return - 1"
- 5 Area 1 system return - 1"
- 6 Water return to outdoor unit 1"
- 7 Water supply system inlet 1/2"
- 8 DHW recirculation 3/4"
- 9 DHW outlet 1/2"
- 10 Supply to solar system 3/4" (optional)
- 11 Return from solar system 3/4" (optional)

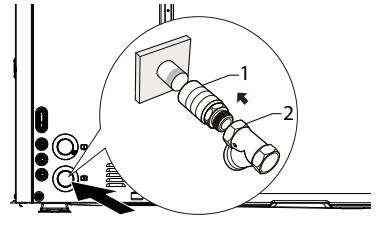
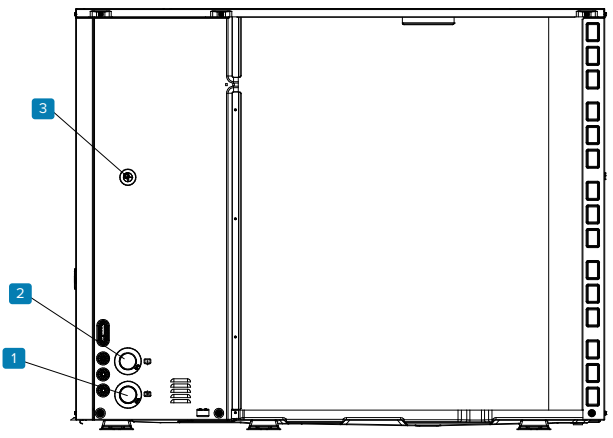

- 1 System supply 1 1/4"
- 2 System return 1 1/4"
- 3 Water side safety valve Ø 16mm

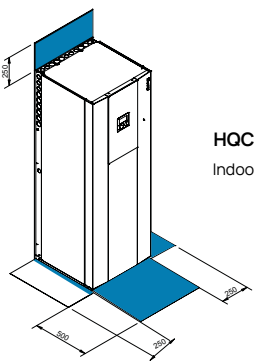

HQCN-NEE 1 TC A
Indoor unit (IDU)

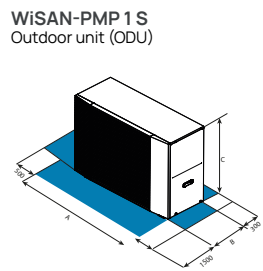

WiSAN-PMP 1 S
Outdoor unit (ODU)

For trouble-free operation of the unit it is essential to maintain the safety distances indicated by the blue areas.

HEAT PUMPS

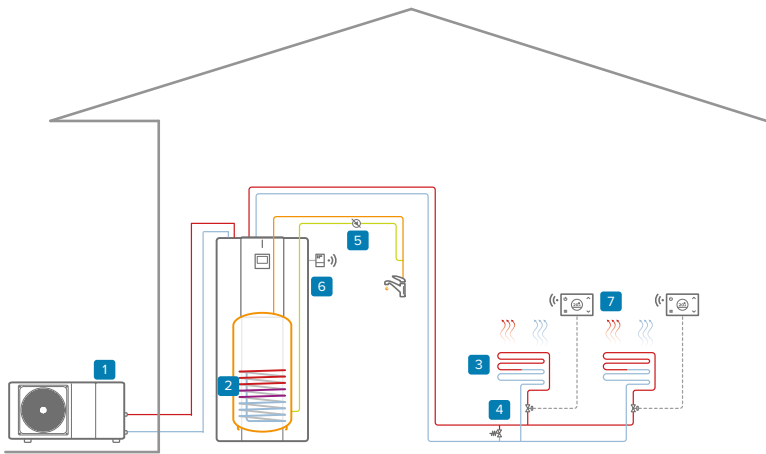

Single-zone system:
Heating / DHW

- 1 Outdoor unit
- 2 Indoor unit
- 3 Heating area
- 4 Bypass*
- 5 DHW recirculation pump
- 6 SwitchConnect Wi-Fi receiver
- 7 HiDTConnect2 Wi-Fi chronothermostat

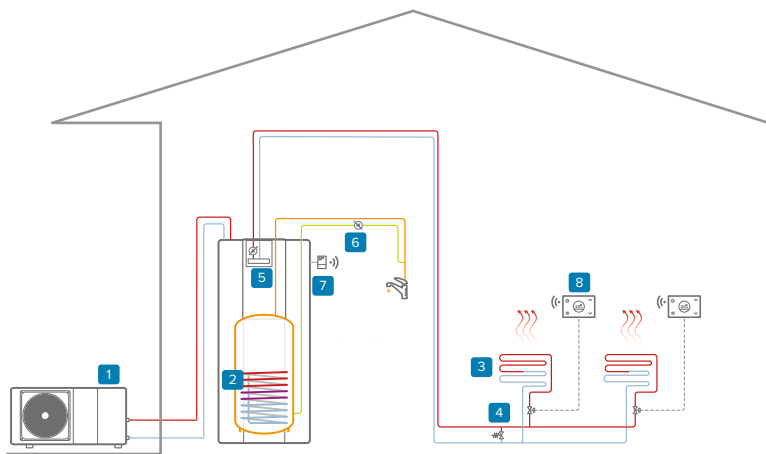

Single booster single-area system:
Heating / DHW

- 1 Outdoor unit
- 2 Indoor unit
- 3 Heating area
- 4 Bypass*
- 5 Hydraulic separator single-area kit plus pump
- 6 DHW recirculation pump
- 7 SwitchConnect Wi-Fi receiver
- 8 HiDTConnect2 Wi-Fi chronothermostat

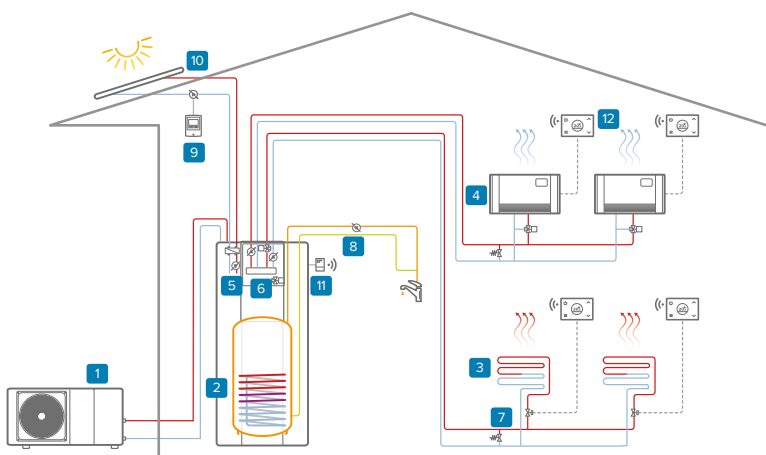

Two zone + solar system
Heating / DHW

- 1 Outdoor unit
- 2 Indoor unit
- 3 Heating area
- 4 Cooling area
- 5 Solar connection kit
- 6 Two-zone kit
- 7 Bypass*
- 8 DHW recirculation pump*
- 9 Solar circulation kit
- 10 ELFOSun3 thermal solar
- 11 SwitchConnect Wi-Fi receiver
- 12 HiDTConnect2 Wi-Fi chronothermostat

The diagrams are for the sole purpose of illustrating the possible combinations of system elements.

*From external supply

HYDRO-SPLIT BOX

Wall-mounted indoor unit for Hydro-split systems



HEAT PUMPS

Energy saving



Solar integration (DHW tank - optional)



Cascade



€-Switch

Comfort



Hot Cold



DHW



Silent

Convenience



Weekley Timer



Instant DHW (Hybrid Version)



Contemporaneity (Hybrid Version)



Integrated DHW tank

Management and connectivity



Input ON/OFF



Port Modbus



Control via App



CONTROL4 NRG management



User interface/thermostat



Clivet Eye monitoring

Reliability



Backup heater (optional)

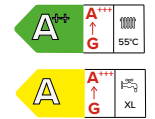

- ✓ Compact module
- ✓ Plug and play
- ✓ Complete (filter - 3-way - inertial)
- ✓ Intuitive connections
- ✓ Dirt separator filter, 3-way DHW valve

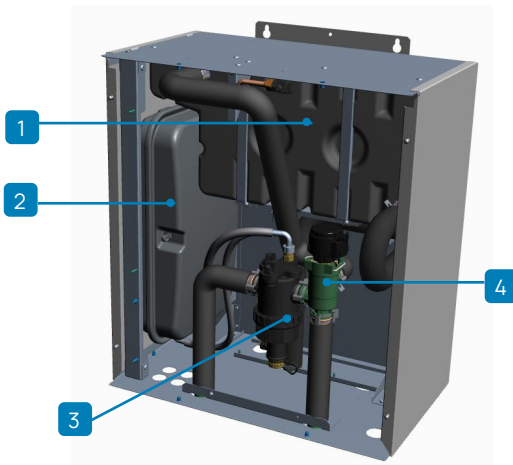

- 1 15-litre inertial tank
- 2 12-litre system expansion tank
- 3 Magnetic dirt separator filter
- 4 3-way valve for DHW

Universal

The BOX version is the hydraulic module similar in size to a boiler that can house the hydraulic components to connect the heat pump to the heating and cooling system. Ready to be combined with the EDGE EVO 2.0 and Edge F range of packaged heat pumps from size 2.1 to 8.1, for a high-level heating and cooling system.







Configurations

CONTROL:









- HMIR32 Can be combined with EDGE EVO 2.0
- HMIR290 Can be combined with EDGE F and EDGE PRO

Hybrid version in combination with Clivet FE boiler

Interior accessories

	EH246X	Additional electric heater adjustable to three capacities of 2, 4 or 6 kW		KIR2HX	Hydraulic kit for managing two areas with the same temperature
	EH9X	Additional electric heater adjustable to one capacity of 9 kW		KIR2HLX	Hydraulic kit for managing two areas with high and mixed temperature
	KCSIX	Secondary circuit kit (1L hydraulic circuit breaker + pump)		SOLX	DHW plate exchanger kit for solar thermal connection
				SICGX	Intermediate exchanger for clean separation between primary and secondary circuit

External accessories

	ACS200X	200 liter DHW tank		T1BX	Water temperature probe 10 m
	ACS300X	300 liter DHW tank		T1B30X	Water temperature probe 30 m
	ACS500X	500 liter DHW tank		VDACSX	Thermostatic switching valve ACS
	SCS08X	Solar coil for boilers ACS ACS200X/ACS300X		KISX	Simplified installation kit with fittings for BOX
	SCS12X	Solar coil for boiler ACS ACS500X			
	ACI40X	System inertial tank 40 litres		HTC2WX	White HID-TConnect2 chronothermostat for temperature control
	ANEDX	Electronic anode		SWCX	Receiver / switch IoT SwitchConnect
	KCAIAX	Water tank connection kit Additional Buffer Tank			

Technical data - BOX version+ EDGE EVO 2.0

Size - Set				2.1	3.1	4.1	5.1	6.1 - 6.1T	7.1 - 7.1T	8.1 - 8.1T	
Heating	Capacity	Water 35/30°C	Nominal / Maximum	kW	4,20 / 6,26	6,35 / 7,41	8,40 / 9,11	10,0 / 10,3	12,1 / 14,6	14,5 / 15,5	15,9 / 16,8
	COP	Outdoor air 7°C	Nominal	-	5,10	4,95	5,15	4,95	4,95	4,60	4,50
	Capacity	Water 35/30°C	Nominal / Maximum	kW	4,70 / 4,99	6,00 / 6,21	7,00 / 7,27	8,00 / 8,31	10,0 / 11,0	12,0 / 12,7	13,1 / 13,9
	COP	Outdoor air -7°C	Nominal	-	3,10	3,00	3,20	3,05	3,00	2,85	2,70
Cooling	Capacity	Water 45/40°C	Nominal / Maximum	kW	4,30 / 5,96	6,30 / 7,13	8,10 / 8,98	10,0 / 10,3	12,3 / 14,5	14,1 / 15,7	16,0 / 16,6
	COP	Outdoor air 7°C	Nominal	-	3,80	3,70	3,85	3,75	3,70	3,60	3,50
	Capacity	Water 18/23°C	Nominal / Maximum	kW	4,50 / 7,65	6,50 / 7,65	8,30 / 11,1	9,90 / 12,0	12,0 / 15,0	13,5 / 15,3	14,2 / 16,4
	EER	Outdoor air 35°C	Nominal	-	5,50	4,80	5,05	4,55	3,95	3,61	3,61
Electrical power for meter sizing	Capacity	Water 7/12°C	Nominal / Maximum	kW	4,70 / 6,14	7,00 / 7,11	7,45 / 7,94	8,20 / 8,67	11,5 / 11,5	12,4 / 12,4	14,0 / 14,0
	EER	Outdoor air 35°C	Nominal	-	3,45	3,00	3,35	3,25	2,75	2,50	2,50
				kW	2,30	2,70	3,40	3,70	5,50	5,80	6,20
				-	A++	A++	A++	A++	A++	A++	A++
Seasonal efficiency Medium climate	Heating	Water 55°C	Annual energy consumption	-	2.749	3.348	4.064	4.541	6.916	6.917	7.213
			SCOP	-	3,31	3,52	3,37	3,47	3,45	3,47	3,41
			ns (seasonal output)	%	129	138	131	137	135	135	133
			Energy class	-	A+++	A+++	A+++	A+++	A+++	A+++	A+++
	Heating	Water 35°C	Annual energy consumption	-	2.354	2.849	3.223	3.649	5.156	5.157	6.011
			SCOP	-	4,85	4,95	5,22	5,20	4,81	4,72	4,62
		ns (seasonal output)	%	191	195	205	205	189	186	182	
Size - Indoor unit					A	A	A	A	A	A	
Power supply	Voltage/Frequency/Phases			V/Hz/n°	220-240/50/1	220-240/50/1	220-240/50/1	220-240/50/1	220-240/50/1	220-240/50/1	
Expansion tank capacity				l	12	12	12	12	12	12	
Sound power	Nominal			dB(A)	41	41	41	41	41	41	
Sound pressure @1m	Nominal			dB(A)	26	26	26	26	26	26	
Size - Outdoor unit					2.1	3.1	4.1	5.1	6.1 - 6.1T	7.1 - 7.1T	8.1 - 8.1T
Power supply	Voltage/Frequency/Phases			V/Hz/n°	220-240/50/1		220-240/50/1		220-240/50/1 - 380-415/50/3+N		
Water flow-rate	Water 35/30°C	Nominal	l/s	0,20	0,30	0,40	0,48	0,58	0,69	0,76	
Pump available pressure	Outdoor air 7°C	Nominal	kPa	85	84	80	71	60	48	40	
Expansion tank capacity				l	4,8	4,8	4,8	4,8	4,8	4,8	
Minimum system water content				l	30	30	40	40	40	40	
Sound power	Minimum / Nominal			dB(A)	53 / 55	55 / 58	54 / 59	55 / 60	59 / 65	59 / 65	59 / 68
Sound pressure @1m	Nominal			dB(A)	45	47	48	50	53	53	57
Expansion tank capacity				l	4,8	4,8	4,8	4,8	4,8	4,8	
Operating range											
Water supply temperature	Heating / DHW	Full electric	Minimum / Maximum	°C	25 / 65						
		Hybrid	Minimum / Maximum	°C	25 / 75						
Operating Voltage Range	Cooling	-	Minimum / Maximum	°C	5 / 25						
	Heating	-	Minimum / Maximum	°C	-25 / 35						
Outdoor air	DHW	-	Minimum / Maximum	°C	-25 / 43						
	Cooling	-	Minimum / Maximum	°C	-5 / 43						

Dimensions and connections

Size				2.1	3.1	4.1	5.1	6.1 - 6.1T	7.1 - 7.1T	8.1 - 8.1T
Dimensions	Indoor unit	AxCxB	mm	547x604x386	547x604x386	547x604x386	547x604x386	547x604x386	547x604x386	547x604x386
	Outdoor unit	AxCxB	mm	1.295x717x400	1.295x717x400	1.385x864x445	1.385x864x445	1.385x864x445	1.385x864x445	1.385x864x445
Operating weight	Indoor unit		kg	47						
	Outdoor unit		kg	86		105			129 - 144	
Refrigerant precharge		type / GWP		R-32 / 675	R-32 / 675	R-32 / 675	R-32 / 675	R-32 / 675	R-32 / 675	R-32 / 675
		kg		1,40	1,40	1,40	1,40	1,75	1,75	1,75
		CO ₂ tons		0,95	0,95	0,95	0,95	1,18	1,18	1,18
External diameters	Indoor unit	Water (System)	inch	1"	1"	1"	1"	1"	1"	1"
	Outdoor unit	Water (System)	inch	1"	1"	1" 1/4	1" 1/4	1" 1/4	1" 1/4	1" 1/4

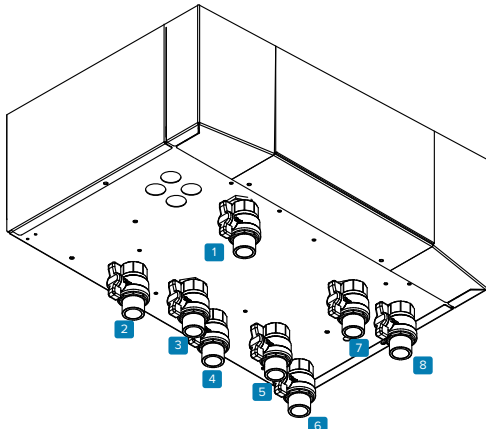

- 1 Water supply from outdoor unit 1"
- 2 Area 1 system return - 1"
- 3 Area 1 system supply - 1"
- 4 Area 2 system return - 1" (optional)
- 5 Area 2 system supply - 1" (optional)
- 6 Water return to outdoor unit 1"
- 7 DHW exchanger return (with optional water tank)
- 8 DHW exchanger supply (with optional water tank)

SIZES 2.1 to 3.1

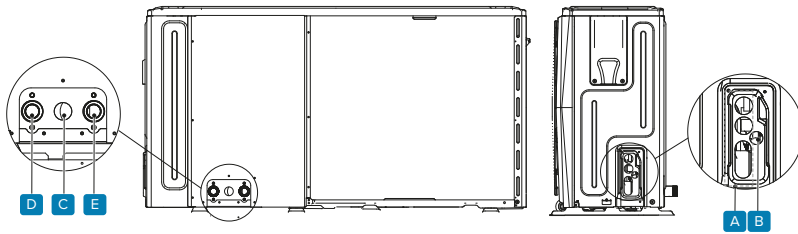

SIZES 4.1 to 8.1

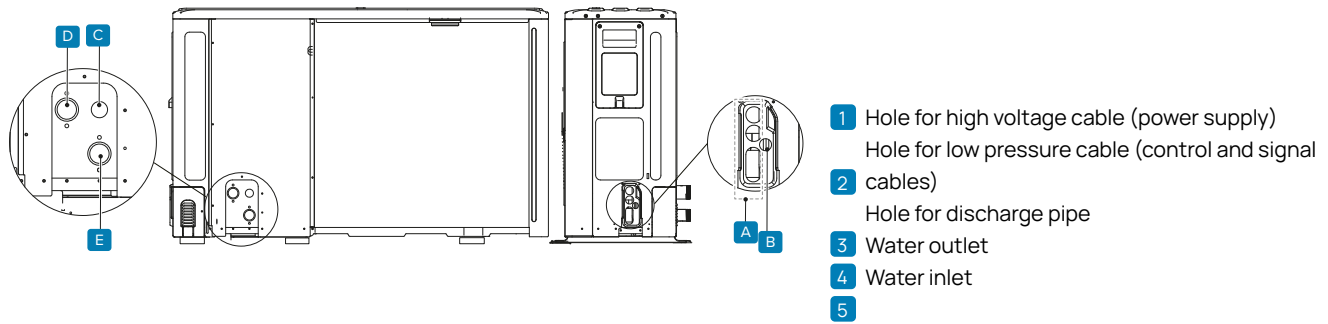

HQCN-NEE 1 BC
Indoor unit (IDU)

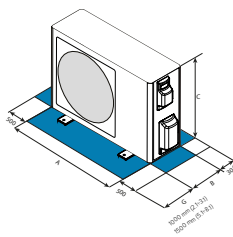
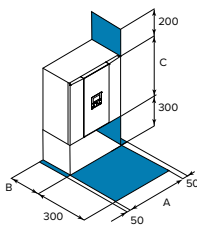

WiSAN-YME 1 S
Outdoor unit (ODU)

Technical data - BOX version + EDGE F

Size - Set				2.1	3.1	4.1	5.1	6.1 - 6.1T	7.1 - 7.1T	8.1 - 8.1T		
Heating	Capacity	Water 35/30°C	Nominal / Maximum	kW	4,50 / 6,86	6,20 / 7,70	8,40 / 10,4	10,0 / 11,0	12,0 / 14,7	14,0 / 16,0	15,0 / 17,6	
	COP	Outdoor air 7°C	Nominal	-	5,15	4,90	5,00	4,70	4,80	4,50	4,40	
	Capacity	Water 35/30°C	Nominal / Maximum	kW	4,50 / 5,56	5,90 / 6,18	7,00 / 8,74	8,00 / 8,89	10,0 / 11,1	11,5 / 12,1	12,7 / 13,2	
	COP	Outdoor air -7°C	Nominal	-	3,10	2,95	3,00	2,85	2,80	2,70	2,50	
Cooling	Capacity	Water 45/40°C	Nominal / Maximum	kW	4,50 / 6,55	6,40 / 7,35	8,20 / 9,57	10,0 / 10,5	12,0 / 14,1	14,0 / 15,3	15,0 / 16,9	
	COP	Outdoor air 7°C	Nominal	-	4,05	3,80	3,85	3,65	3,70	3,50	3,35	
	Capacity	Water 18/23°C	Nominal / Maximum	kW	4,90 / 7,84	5,90 / 9,75	8,30 / 11,4	10,0 / 12,1	12,0 / 16,4	14,0 / 17,3	16,0 / 18,6	
	EER	Outdoor air 35°C	Nominal	-	5,50	5,10	5,15	4,75	4,50	4,20	3,90	
Electrical power for meter sizing	Capacity	Water 7/12°C	Nominal / Maximum	kW	4,70 / 5,66	6,80 / 7,14	7,50 / 8,19	8,90 / 8,90	11,5 / 12,0	12,7 / 12,7	14,0 / 14,3	
	EER	Outdoor air 35°C	Nominal	-	3,65	3,10	3,45	3,25	3,05	2,90	2,75	
Seasonal efficiency Medium climate	Energy class			-	A++	A++	A++	A++	A++	A++	A++	
	Heating Water 55°C	Annual energy consumption			-	2.684	3.164	3.676	4.215	6.847	7.414	8.349
		SCOP			-	3,79	3,82	3,82	3,82	3,62	3,62	3,57
	ns (seasonal output)			%	148,7	149,7	149,7	149,8	141,8	141,9	139,9	
	Energy class			-	A+++	A+++	A+++	A+++	A+++	A+++	A+++	
	Heating Water 35°C	Annual energy consumption			-	2.040	2.692	3.187	3.734	5.376	6.091	6.630
		SCOP			-	5,09	4,91	5,20	5,07	4,68	4,64	4,59
	ns (seasonal output)			%	200,7	193,5	204,8	199,8	184,0	182,4	180,6	
Size - Indoor unit				A	A	A	A	B	B	B		
Power supply	Voltage/Frequency/Phases			V/Hz/n ^ø	230/50/1	230/50/1	230/50/1	230/50/1	230/50/1	230/50/1		
Expansion tank capacity				l	12	12	12	12	12	12		
Sound power	Nominal			dB(A)	41	41	41	41	41	41		
Sound pressure @1m	Nominal			dB(A)	26	26	26	26	26	26		
Size - Outdoor unit				2.1	3.1	4.1	5.1	6.1 - 6.1T	7.1 - 7.1T	8.1 - 8.1T		
Power supply	Voltage/Frequency/Phases			V/Hz/n ^ø	230/50/1			220-240/50/1 - 380-415/50/3+N				
Water flow-rate	Water 35/30°C	Nominal	l/s	0,21	0,30	0,40	0,48	0,57	0,67	0,71		
Pump available pressure	Outdoor air 7°C	Nominal	kPa	89	87	80	71	63	54	49		
Expansion tank capacity				l	8	8	8	8	8	8		
Minimum system water content				l	30	30	40	40	40	40		
Sound power	Minimum / Nominal			dB(A)	51 / 56	53 / 58	55 / 60	56 / 61	58 / 65	59 / 65		
Sound pressure @1m	Minimum / Nominal			dB(A)	40 / 44	42 / 46	42 / 48	43 / 49	43 / 51	44 / 52		
Operating range												
Water supply temperature	Heating / DHW	Full electric	Minimum / Maximum	°C						25 / 75		
		Hybrid	Minimum / Maximum	°C						25 / 75		
Operating Voltage Range	Heating	-	Minimum / Maximum	°C						5 / 25		
		-	Minimum / Maximum	°C						-25 / 35		
Outdoor air	Cooling	-	Minimum / Maximum	°C						-25 / 43		
		-	Minimum / Maximum	°C						-5 / 43		

Dimensions and connections

Size				2.1	3.1	4.1	5.1	6.1 - 6.1T	7.1 - 7.1T	8.1 - 8.1T
Dimensions	Indoor unit	AxCxB	mm	547x604x386	547x604x386	547x604x386	547x604x386	547x604x386	547x604x386	547x604x386
	Outdoor unit	AxCxB	mm	1.295x718x371	1.295x718x371	1.385x865x423	1.385x865x423	1.385x865x423	1.385x865x423	1.385x865x423
Operating weight	Indoor unit		kg	52	52	52	52	52	52	52
	Outdoor unit		kg	90	90	117	117	135	135	135
Refrigerant precharge	type / GWP			R-290 / 0.02	R-290 / 0.02	R-290 / 0.02	R-290 / 0.02	R-290 / 0.02	R-290 / 0.02	R-290 / 0.02
	kg			0,70	0,70	1,10	1,10	1,25	1,25	1,25
	CO ₂ tons			0,002	0,002	0,003	0,003	0,004	0,004	0,004
External diameters	Indoor unit	Water (System)	inch	1"	1"	1"	1"	1"	1"	1"
	Outdoor unit	Water (System)	inch	1"	1"	1" 1/4	1" 1/4	1" 1/4	1" 1/4	1" 1/4

Connection detail

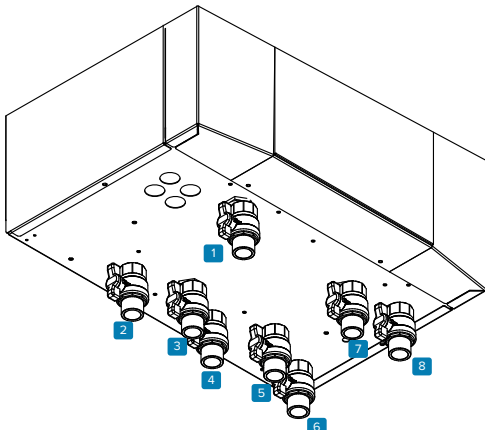

- 1 Water supply from outdoor unit 1"
- 2 Area 1 system return - 1"
- 3 Area 1 system supply - 1"
- 4 Area 2 system return - 1" (optional)
- 5 Area 2 system supply - 1" (optional)
- 6 Water return to outdoor unit 1"
- 7 DHW exchanger return (with optional water tank)
- 8 DHW exchanger supply (with optional water tank)

SIZES 2.1 to 3.1

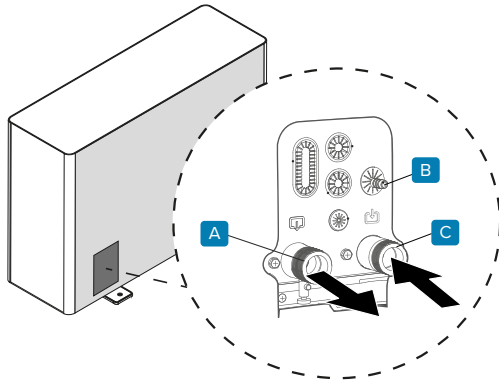

- A 1" system supply
- B Pressure relief valve Ø 16 mm
- C 1" system return

SIZES 4.1 to 8.1

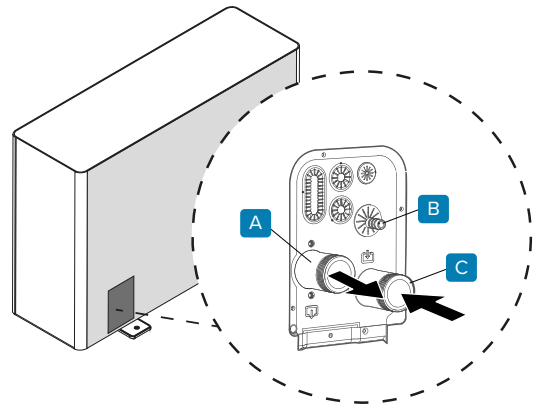

- A System supply 1 1/4"
- B Pressure relief valve Ø 16 mm
- C System return 1 1/4"

HOCN-NEE 1 BC
Indoor unit (IDU)

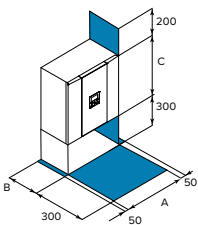

WiSAN-PME 1 S
Outdoor unit (ODU)

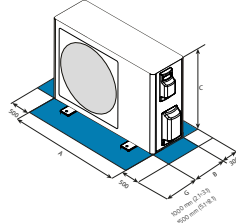

G = 1000 mm (2.1+3.1) / 1500 mm (5.1+8.1)

For trouble-free operation of the unit it is essential to maintain the safety distances indicated by the blue areas.

Technical data - BOX version + EDGE PRO

Size - Set				2.1	3.1	4.1	5.1	6.1 - 6.1T	7.1 - 7.1T	8.1 - 8.1T	
Heating	Capacity	Water 35/30°C	Nominal / Maximum	kW	4,10 / 7,72	6,10 / 8,99	8,00 / 11,6	9,50 / 12,6	12,1 / 15,0	14,0 / 16,3	15,5 / 17,7
	COP	Outdoor air 7°C	Nominal	-	5,30	5,03	5,25	4,95	4,95	4,70	4,50
	Capacity	Water 35/30°C	Nominal / Maximum	kW	4,10 / 6,70	6,00 / 7,63	7,00 / 9,12	8,00 / 9,64	10,0 / 12,4	12,0 / 14,6	13,1 / 15,7
	COP	Outdoor air -7°C	Nominal	-	3,25	3,03	3,25	3,15	3,15	2,80	2,70
Cooling	Capacity	Water 45/40°C	Nominal / Maximum	kW	4,50 / 7,27	6,40 / 8,51	8,10 / 11,0	9,50 / 12,2	12,3 / 14,5	14,1 / 16,0	15,5 / 17,3
	COP	Outdoor air 7°C	Nominal	-	4,17	3,91	4,00	3,90	3,90	3,75	3,65
	Capacity	Water 18/23°C	Nominal / Maximum	kW	4,50 / 8,36	6,50 / 10,8	8,30 / 11,0	10,0 / 11,9	12,0 / 17,1	14,0 / 18,2	16,0 / 18,9
	EER	Outdoor air 35°C	Nominal	-	5,65	5,51	5,25	4,60	4,60	4,40	4,25
Electrical power for meter sizing	Capacity	Water 7/12°C	Nominal / Maximum	kW	4,70 / 6,96	6,80 / 9,03	7,50 / 9,19	8,10 / 9,90	11,5 / 13,9	12,4 / 14,9	14,0 / 16,7
	EER	Outdoor air 35°C	Nominal	-	3,65	3,10	3,35	3,10	3,05	3,00	2,70
Seasonal efficiency Medium climate	Heating Water 55°C	Energy class	-	-	A+++	A+++	A+++	A+++	A+++	A+++	A+++
		Annual energy consumption	-	2.647	3.120	4.056	5.145	6.266	7.479	8.013	
		SCOP	-	3,91	3,98	4,08	4,02	3,96	3,87	3,87	
		ns (seasonal output)	%	153	156	160	158	155	152	152	
	Heating Water 35°C	Energy class	-	-	A+++	A+++	A+++	A+++	A+++	A+++	A+++
		Annual energy consumption	-	1.984	2.460	3.095	3.889	5.014	6.069	7.009	
		SCOP	-	5,10	5,00	5,35	5,33	4,94	4,76	4,72	
		ns (seasonal output)	%	206	199	211	210	195	188	186	
Size - Indoor unit				A							
Power supply	Voltage/Frequency/Phases		V/Hz/n°	220-240/50/1							
Expansion tank capacity			l	12							
Sound power			Nominal dB(A)	41							
Sound pressure @1m			Nominal dB(A)	26							
Size - Outdoor unit				2.1	3.1	4.1	5.1	6.1 - 6.1T	7.1 - 7.1T	8.1 - 8.1T	
Power supply	Voltage/Frequency/Phases		V/Hz/n°	220-240/50/1							
Water flow-rate	Water 35/30°C	Nominal	l/s	0,20	0,30	0,40	0,50	0,60	0,70	0,70	
Pump available pressure	Outdoor air 7°C	Nominal	kPa	56	56	51	51	45	42	38	
Expansion tank capacity			l	48							
Minimum system water content			l	30							
Sound power			Minimum / Nominal dB(A)	46 / 48	46 / 50	47 / 52	47 / 52	48 / 52	48 / 55	48 / 56	
Sound pressure @1m			Minimum / Nominal dB(A)	31 / 33	32 / 34	33 / 35	35 / 37	38 / 37	38 / 40	39 / 41	
Operating range											
Water supply temperature	Heating / DHW	Full electric	Minimum / Maximum	°C							
		Hybrid	Minimum / Maximum	°C							
Operating Voltage Range	Heating	-	Minimum / Maximum	°C							
		DHW	-	Minimum / Maximum	°C						
Outdoor air	Cooling	-	Minimum / Maximum	°C							
		-	Minimum / Maximum	°C							

Dimensions and connections

Size				2.1	3.1	4.1	5.1	6.1 - 6.1T	7.1 - 7.1T	8.1 - 8.1T
Dimensions	Indoor unit	AxCxB	mm	547x604x386						
	Outdoor unit	AxCxB	mm	1.330x1.051x528						
Operating weight	Indoor unit	-	kg	52						
	Outdoor unit	-	kg	150	155 - 160				175 - 180	
Refrigerant precharge			type / GWP	R-290 / 0.02						
			kg	0,42	0,64		0,69	0,89	1,00	1,08
			CO ₂ tons	0,00002						
External diameters	Indoor unit	Water (System)	inch	1"						
	Outdoor unit	Water (System)	inch	1" 1/4						

Connection detail

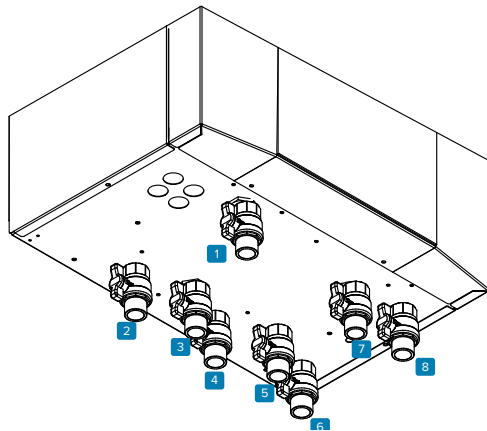

- 1 Water supply from outdoor unit 1"
- 2 Area 1 system return - 1"
- 3 Area 1 system supply - 1"
- 4 Area 2 system return - 1" (optional)
- 5 Area 2 system supply - 1" (optional)
- 6 Water return to outdoor unit 1"
- 7 DHW exchanger return (with optional water tank)
- 8 DHW exchanger supply (with optional water tank)

HEAT PUMPS

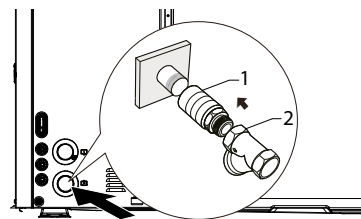
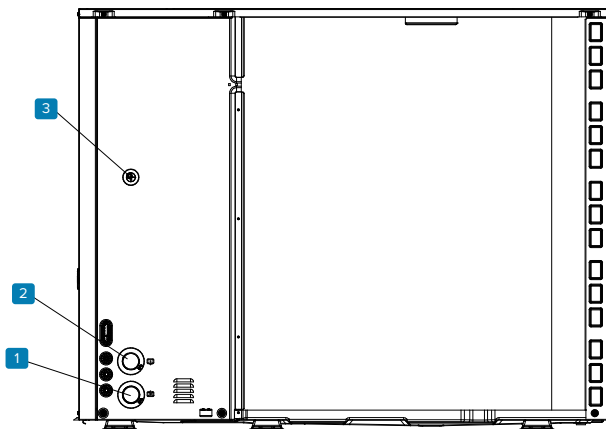

- 1 System supply 1 1/4"
- 2 System return 1 1/4"
- 3 Water side safety valve \varnothing 16mm

HQCN-NEE 1 BC
Indoor unit (IDU)

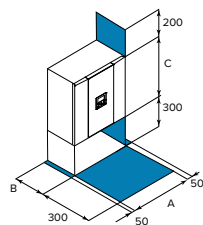

WiSAN-PMP 1 S
Outdoor unit (ODU)

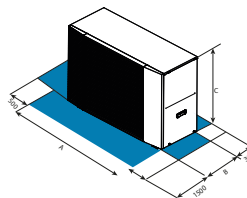

For trouble-free operation of the unit it is essential to maintain the safety distances indicated by the blue areas.

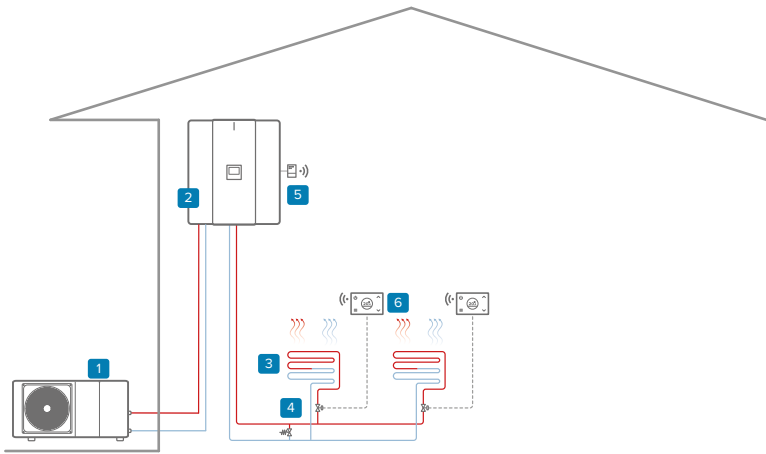

Single-zone system:
Heating / DHW

- 1 Outdoor unit
- 2 Indoor unit
- 3 Heating system
- 4 Bypass*
- 5 SwitchConnect Wi-Fi receiver
- 6 HiDTConnect2 Wi-Fi chronothermostat

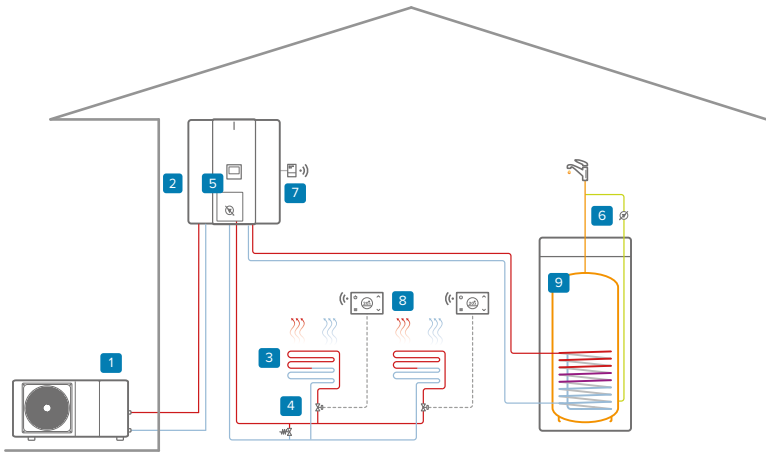

Single-area system + external DHW
water tank:
Heating / DHW

- 1 Outdoor unit
- 2 Indoor unit
- 3 Heating system
- 4 Bypass*
- 5 Hydraulic separator kit + pump
- 6 DHW recirculation pump
- 7 SwitchConnect Wi-Fi receiver
- 8 HiDTConnect2 Wi-Fi chronothermostat
- 8 DHW tank

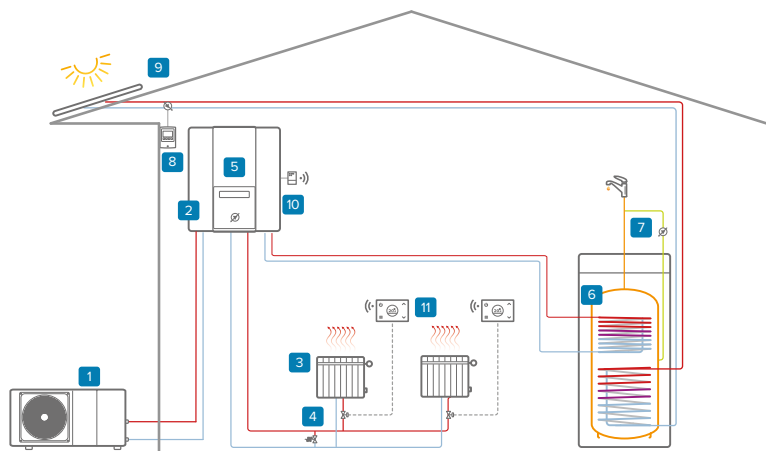

Two-area system + water tank + solar:
Heating / DHW

- 1 Outdoor unit
- 2 Indoor unit
- 3 Heating system
- 4 Bypass*
- 5 Single-area kit
- 6 DHW tank
- 7 DHW recirculation pump
- 8 Solar circulation kit
- 9 ELFOSun2 solar thermal
- 10 SwitchConnect Wi-Fi receiver
- 11 HiDTConnect2 Wi-Fi chronothermostat

The diagrams are for the sole purpose of illustrating the possible combinations of system elements.

*From external supply

HYDRO-SPLIT INVISIBLE

Uncased indoor unit for Hydro-split systems



HEAT PUMPS

Energy saving



Solar integration (DHW tank - optional)



€-Switch

Comfort



Hot Cold



DHW



Silent

Convenience



Weekly Timer



Instant DHW (Hybrid Version)



Contemporaneity (Hybrid Version)



Integrated DHW tank

Health



Renewable Energy (Full electric version)

Management and connectivity



Input ON/ OFF



Modbus port



Control via App



Control/4 NRG management



User interface/ thermostat



Clivet Eye monitoring

Reliability



Backup heater (optional)

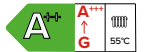

- ✓ Ultra thin only 35 cm
- ✓ Complete (deflector filter - expansion vessel - anti-scalding - 15 l inertia)
- ✓ Versatile with a wide range of accessories
- ✓ Aesthetic additional practical cabinet for system accessories for outdoor installation

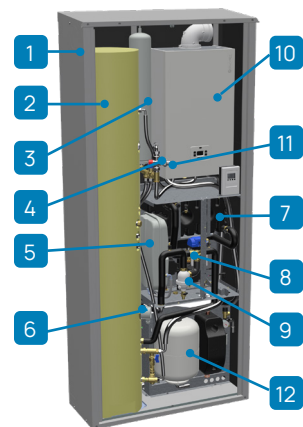
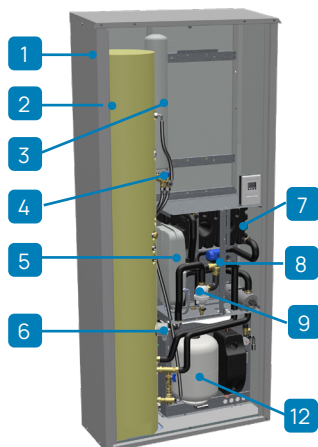

- 1 Visible cabinet
- 2 Domestic hot water storage tank
- 3 Sanitary expansion tank
- 4 Thermostatic anti-scald valve
- 5 Plant expansion tank
- 6 Backup electric heater
- 7 Inertial tank
- 8 3-way valve for DHW
- 9 Magnetic deflector filter+safety valve
- 10 Condensation boiler with instantaneous DHW
- 11 Thermostated boiler bypass valve
- 12 Solar kit (control unit-expansion tank-pump unit)

Installation also visible

The INVISIBLE version is the uncased hydronic module, which makes it possible to have the complete heating and DHW production system inside the wall, without occupying any surface area in the building



Configurations

CONTROL:

- HMIR32 Can be combined with EDGE EVO 2.0
- HMIR290 Can be combined with EDGE F and EDGE PRO











Hybrid version in combination with FE 24.4 e FE 33.4 Boiler
(see the relevant paragraph for boiler data)

Mandatory accessories

	ADIX	Main uncased additional practical cabinet for system accessories
	ACS150X	150-litre DHW tank

	KCIACSX	DHW storage connection kit
---	---------	----------------------------

External accessories

	AENVX	Aesthetic cabinet for visible installation (NEW)
	DPX	Template for connecting the additional aesthetic practical cabinet for system accessories in full view
	KCSIX	Single zone kit
	KIR2HX	Hydraulic kit for managing two areas with the same temperature
	KIR2HLX	Hydraulic kit for managing two areas with high and mixed temperature
	EH246X	Additional electric heater adjustable to three capacities of 2, 4 or 6 kW
	EH9X	Additional electric heater adjustable to one capacity of 9 kW
	SICGX	Intermediate heat exchanger for glycol circuit (NEW)
	ACSA150X	Additional 150-litre DHW tank
	ACSA50X	Additional 50-litre DHW tank

	KCI150X	Additional 150-litre tank connection kit
	ADIAX	Cabinet for additional 150-litre DHW tank
	KCVEX	Solar controller module + pump + expansion tank
	SHWTX	DHW tank with heat exchanger for connection to solar panel
	ADI50X	Additional built-in cabinet for storage tank / solar kit
	KCIBOIX	Boiler connection kit for instantaneous DHW production
	AC50X	50 liter system inertial storage tank (for installation inside the unit)
	ACE50X	50 liter system inertial storage tank (for installation outside the unit)
	KAIAX	DHW tank connection kit for uncased unit
	KPRSX	Sanitary recirculation pump kit (for installation inside the unit)

Technical data - INVISIBLE version + Edge EVO 2.0 EXC

HEAT PUMPS

Size					2.1	3.1	4.1	5.1
Heating	Capacity	Water 35/30 °C	Nominal / Maximum	kW	4,20 / 6,26	6,35 / 7,41	8,40 / 9,11	10,0 / 10,3
	COP	Outdoor air 7 °C	Nominal	-	5,10	4,95	5,15	4,95
	Capacity	Water 35/30 °C	Nominal / Maximum	kW	4,70 / 4,99	6,00 / 6,21	7,00 / 7,27	8,00 / 8,31
	COP	Outdoor air -7 °C	Nominal	-	3,10	3,00	3,20	3,05
	Capacity	Water 45/40 °C	Nominal / Maximum	kW	4,30 / 5,96	6,30 / 7,13	8,10 / 8,98	10,0 / 10,3
	COP	Outdoor air 7 °C	Nominal	-	3,80	3,70	3,85	3,75
Cooling	Capacity	Water 18/23 °C	Nominal / Maximum	kW	4,50 / 7,65	6,50 / 7,65	8,30 / 11,1	9,90 / 12,0
	EER	Outdoor air 35 °C	Nominal	-	5,50	4,80	5,05	4,55
	Capacity	Water 7/12 °C	Nominal / Maximum	kW	4,70 / 6,14	7,00 / 7,11	7,45 / 7,94	8,20 / 8,67
	EER	Outdoor air 35 °C	Nominal	-	3,45	3,00	3,35	3,25
	Net tank capacity			l	143	143	143	143
	DHW	Water mixed at 40 °C (V40)1		l	188	188	188	188
	Heating time		h:min	2:11	2:11	1:47	1:47	
Electrical power for meter sizing				kW	2,30	2,70	3,40	3,70
Seasonal efficiency Medium climate	Energy class			-	A++	A++	A+	A++
	Heating	Annual energy consumption		-	2.749	3.348	4.064	4.541
	Water 55 °C	SCOP		-	3,31	3,52	3,37	3,47
		ns (seasonal output)		%	129	138	131	137
	Energy class			-	A+++	A+++	A+++	A+++
	Heating	Annual energy consumption		-	2.354	2.849	3.223	3.649
	Water 35 °C	SCOP		-	4,85	4,95	5,22	5,20
		ns (seasonal output)		%	191	195	205	205
	Energy class			-	A+	A+	A+	A+
	DHW	Withdrawal profile		-	L	L	L	L
	Size - Indoor unit				TO	TO	TO	TO
	Power supply	Voltage/Frequency/Phases			V/Hz/n °	220-240/50/1	220-240/50/1	220-240/50/1
Expansion tank capacity				l	12	12	12	12
Sound power	Nominal			dB(A)	41	41	41	41
Sound pressure @1m	Nominal			dB(A)	26	26	26	26
Boiler - Hybrid version					GAS BOILER FE 24.4	GAS BOILER FE 24.4	GAS BOILER FE 24.4	GAS BOILER FE 24.4
Boiler	Nominal Heating capacity ((LHV)	Water 80/60 °C	Nominal	kW	24,0	24,0	24,0	24,0
	Efficiency		Nominal	%	97,8	97,8	97,8	97,8
Power supply	Voltage/Frequency/Phases			V/Hz/n °	220-240/50/1	220-240/50/1	220-240/50/1	220-240/50/1
Power input	Water content			W	82	82	82	82
Sound power	Nominal			dB(A)	49	49	49	49
Size - Outdoor unit					2.1	3.1	4.1	5.1
Power supply	Voltage/Frequency/Phases			V/Hz/n °	220-240/50/1	220-240/50/1	220-240/50/1	220-240/50/1
Water flow-rate	Water 35/30 °C	Nominal	l/s	0,20	0,30	0,40	0,48	
Pump available pressure	Outdoor air 7 °C	Nominal	kPa	85	84	80	71	
Minimum system water content				l	30	30	40	40
Expansion tank capacity				l	4,8	4,8	4,8	4,8
Sound power	Minimum / Nominal			dB(A)	53 / 55	55 / 58	54 / 59	55 / 60
Sound pressure @1m	Nominal			dB(A)	45	47	48	50
Operating range								
Water supply temperature	Heating / DHW	Full electric	Minimum / Maximum	°C	25 / 65	25 / 65	25 / 65	25 / 65
		Hybrid	Minimum / Maximum	°C	25 / 75	25 / 75	25 / 75	25 / 75
	Cooling	-	Minimum / Maximum	°C	5 / 25	5 / 25	5 / 25	5 / 25
Operating Voltage Range	Heating / DHW	-	Minimum / Maximum	°C	-25 / 43	-25 / 43	-25 / 43	-25 / 43
	DHW	-	Minimum / Maximum	°C	-25 / 43	-25 / 43	-25 / 43	-25 / 43
Outdoor air		-	Minimum / Maximum	°C	-5 / 43	-5 / 43	-5 / 43	-5 / 43
	Cooling	-	Minimum / Maximum	°C	-5 / 43	-5 / 43	-5 / 43	-5 / 43

Data according to EN 14511:2022 and EN 14825:2022
 The Product complies with the European ErP Directive (EU Regulations 811/2013 - 813/2013 - 2016/2281). Energy classes with Control4 NRG system control

(1) Data according to EN 16147: amount of water at 40 °C with the same enthalpy content as the water coming out of the Boiler at a temperature higher than 40 °C

Dimensions and connections

Size					2.1	3.1	4.1	5.1
Dimensions	Indoor unit	AxCxB	mm		950x2.200x360	950x2.200x360	950x2.200x360	950x2.200x360
	Outdoor unit	AxCxB	mm		1.295x717x400	1.295x717x400	1.385x864x445	1.385x864x445
Operating weight	Indoor unit		kg		317	317	317	317
	Boiler		kg		31	31	31	31
	Outdoor unit		kg		86	86	105	105
Refrigerant charge			type / GWP		R-32 / 675	R-32 / 675	R-32 / 675	R-32 / 675
			kg		1,40	1,40	1,40	1,40
			CO ₂ tons		0,95	0,95	0,95	0,95
Boiler Hybrid version	Indoor unit	Water (System)	inch		1"	1"	1"	1"
		Water (DHW)	inch		3/4"	3/4"	3/4"	3/4"
	Outdoor unit	Water (System)	inch		1"	1"	1 1/4"	1 1/4"
		Gas	inch		3/4"	3/4"	3/4"	3/4"
		Intake air	mm		80	80	80	80
	Exhaust gas	mm		80	80	80	80	

Connection detail

SIZES 2.1 to 3.1

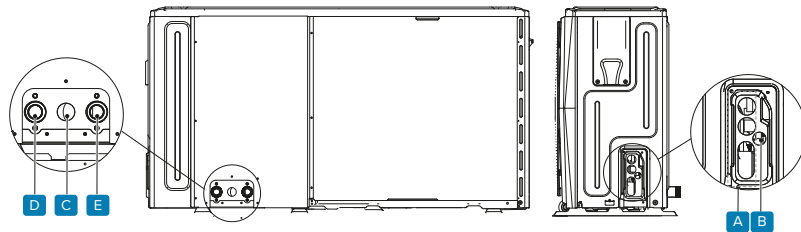

SIZES 4.1 to 8.1

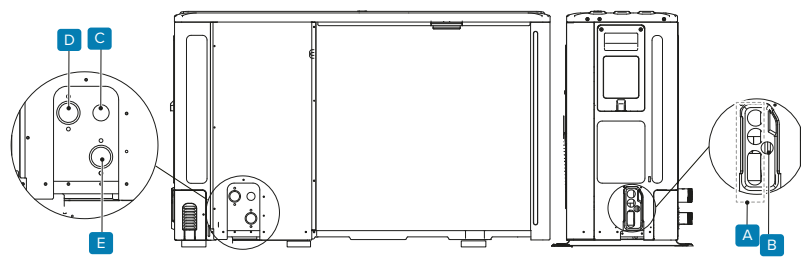

- 1 Hole for high voltage cable (power supply)
- 2 Hole for low pressure cable (control and signal cables)
- 3 Hole for discharge pipe
- 4 Water outlet
- 5 Water inlet

HQCN-NEE 1 IC
Indoor unit (IDU)

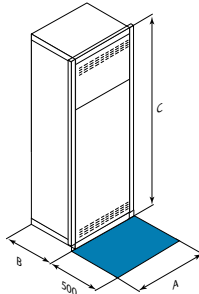

WiSAN-YME
Outdoor unit (ODU)

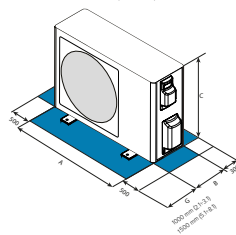

For trouble-free operation of the unit it is essential to maintain the safety distances indicated by the blue areas.

Technical data - INVISIBLE version + EDGE F

Size				2.1	3.1	4.1	5.1	
Heating	Capacity	Water 35/30 °C	Nominal / Maximum	kW	4,50 / 6,86	6,20 / 7,70	8,40 / 10,4	10,0 / 11,0
	COP	Outdoor air 7 °C	Nominal	-	5,15	4,90	5,00	4,70
	Capacity	Water 35/30 °C	Nominal / Maximum	kW	4,50 / 5,56	5,90 / 6,18	7,00 / 8,74	8,00 / 8,89
	COP	Outdoor air -7 °C	Nominal	-	3,10	2,95	3,00	2,85
Cooling	Capacity	Water 45/40 °C	Nominal / Maximum	kW	4,50 / 6,55	6,40 / 7,35	8,20 / 9,57	10,0 / 10,5
	COP	Outdoor air 7 °C	Nominal	-	4,05	3,80	3,85	3,65
	Capacity	Water 18/23 °C	Nominal / Maximum	kW	4,50 / 7,84	6,50 / 9,75	8,30 / 11,4	10,0 / 12,1
	EER	Outdoor air 35 °C	Nominal	-	5,50	5,10	5,15	4,75
DHW	Capacity	Water 7/12 °C	Nominal / Maximum	kW	4,70 / 5,66	6,80 / 7,14	7,50 / 8,19	8,90 / 8,90
	EER	Outdoor air 35 °C	Nominal	-	3,65	3,10	3,45	3,25
	Net tank capacity			l	143	143	143	143
	Water mixed at 40 °C (V40)			l	188	188	188	188
			Heating time	h:min	02:11	02:11	01:47	01:47
Electrical power for meter sizing				kW	2,70	3,00	3,60	3,90
Seasonal efficiency Medium climate			Energy class	-	A++	A++	A++	A++
	Heating	Water 55 °C	Annual energy consumption	-	2.684	3.164	3.676	4.215
			SCOP	-	3,79	3,81	3,81	3,82
			ns (seasonal output)	%	148,7	149,7	149,7	149,8
			Energy class	-	A+++	A+++	A+++	A+++
	Heating	Water 35 °C	Annual energy consumption	-	2.040	2.692	3.187	3.734
			SCOP	-	5,09	4,91	5,20	5,07
			ns (seasonal output)	%	200,7	193,5	204,8	199,8
DHW			Energy class	-	A+	A+	A+	
			Withdrawal profile	-	L	L	L	
Size - Indoor unit					A	A	A	
Power supply	Voltage/Frequency/Phases			V/Hz/n°	220-240/50/1	220-240/50/1	220-240/50/1	220-240/50/1
Expansion tank capacity				l	12	12	12	12
Sound power	Nominal			dB(A)	41	41	41	41
Sound pressure @1m	Nominal			dB(A)	26	26	26	26
Boiler - Hybrid version					GAS BOILER FE 24.4			
Boiler	Nominal Heating capacity ((LHV)	Water 80/60 °C	Nominal	kW	24,0	24,0	24,0	24,0
			Efficiency	%	97,8	97,8	97,8	97,8
Power supply	Voltage/Frequency/Phases			V/Hz/n°	220-240/50/1	220-240/50/1	220-240/50/1	220-240/50/1
Power input	Water content			W	82	82	82	82
Sound power	Nominal			dB(A)	49	49	49	49
Size - Outdoor unit					2.1	3.1	4.1	5.1
Power supply	Voltage/Frequency/Phases			V/Hz/n°	220-240/50/1	220-240/50/1	220-240/50/1	220-240/50/1
Water flow-rate	Water 35/30 °C	Nominal	l/s	0,21	0,30	0,40	0,48	
Pump available pressure	Outdoor air 7 °C	Nominal	kPa	89	87	80	71	
Minimum system water content				l	30	30	40	40
Expansion tank capacity				l	8	8	8	8
Sound power	Minimum / Nominal			dB(A)	51 / 56	53 / 58	55 / 60	56 / 61
Sound pressure @1m	Minimum / Nominal			dB(A)	40 / 44	42 / 46	42 / 48	43 / 49
Operating range								
Water supply temperature	Heating / DHW	Full electric	Minimum / Maximum	°C	25 / 75	25 / 75	25 / 75	25 / 75
		Hybrid	Minimum / Maximum	°C	25 / 75	25 / 75	25 / 75	25 / 75
	Cooling	-	Minimum / Maximum	°C	5 / 25	5 / 25	5 / 25	5 / 25
Operating Voltage Range	Heating / DHW	-		Minimum / Maximum	°C	-25 / 35	-25 / 35	-25 / 35
		DHW		-		Minimum / Maximum	°C	-25 / 46
Outdoor air	-		Minimum / Maximum	°C	-5 / 46	-5 / 46	-5 / 46	-5 / 46
	Cooling		-		Minimum / Maximum	°C	-5 / 46	-5 / 46

Data according to EN 14511:2022 and EN 14825:2022
 The Product complies with the European ErP Directive (EU Regulations 811/2013 - 813/2013 - 2016/2281). Energy classes with Control4 NRG system control

(1) Data according to EN 16147: amount of water at 40 °C with the same enthalpy content as the water coming out of the Boiler at a temperature higher than 40 °C

Dimensions and connections

Size				2.1	3.1	4.1	5.1
Dimensions	Indoor unit	AxCxB	mm	950x2.200x360	950x2.200x360	950x2.200x360	950x2.200x360
	Outdoor unit	AxCxB	mm	1.295x718x381	1.295x718x381	1.385x865x423	1.385x865x423
Operating weight	Indoor unit		kg	317	317	317	317
	Boiler		kg	31	31	31	31
	Outdoor unit		kg	90	90	117	117
Refrigerant charge			type / GWP	R-290 / 0.02	R-290 / 0.02	R-290 / 0.02	R-290 / 0.02
			kg	0,70	0,70	1,10	1,10
			CO ₂ tons	0,002	0,002	0,003	0,003
	Indoor unit	Water (System)	inch	1"	1"	1"	1"
Water (DHW)		inch	3/4"	3/4"	3/4"	3/4"	
Outdoor unit		Water (System)	inch	1"	1"	1" 1/4	
Boiler Hybrid version	Gas		inch	3/4"	3/4"	3/4"	3/4"
	Intake air		mm	80	80	80	80
	Exhaust gas		mm	80	80	80	80

Connection detail

1

SIZES 2.1 to 3.1

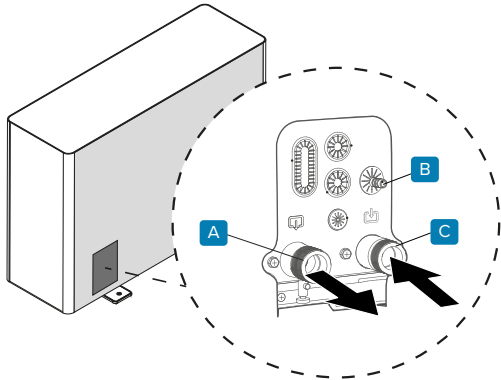

- A** 1" system supply
- B** Pressure relief valve Ø 16 mm
- C** 1" system return

SIZES 4.1 to 8.1

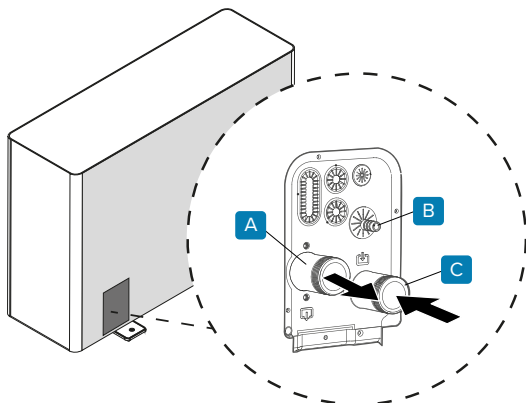

- A**
- B**
- C**

System supply 1 1/4"
 Pressure relief valve Ø 16 mm
 System return 1 1/4"

HQCN-NEE 1 IC
 Indoor unit (IDU)

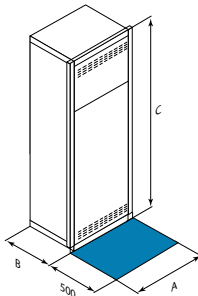

WiSAN-PME 1 S
 Outdoor unit (ODU)

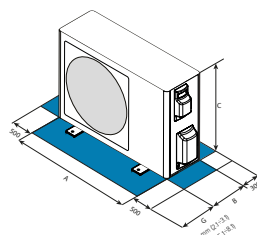

- E = 500 mm
- F = 500 mm
- G = 1000 mm (2.1÷3.1)
- H = 300 mm

For trouble-free operation of the unit it is essential to maintain the safety distances indicated by the blue areas.

Technical data - INVISIBLE version + EDGE PRO

Size			2.1	3.1	4.1 - 4.1T	5.1 - 5.1T		
Heating	Capacity	Water 35/30 °C	Nominal / Maximum	kW	4,50 / 6,86	6,20 / 7,70	8,40 / 10,4	10,0 / 11,0
	COP	Outdoor air 7 °C	Nominal	-	5,15	4,90	5,00	4,70
	Capacity	Water 35/30 °C	Nominal / Maximum	kW	4,50 / 5,56	5,90 / 6,18	7,00 / 8,74	8,00 / 8,89
	COP	Outdoor air -7 °C	Nominal	-	3,10	2,95	3,00	2,85
Cooling	Capacity	Water 45/40 °C	Nominal / Maximum	kW	4,50 / 6,55	6,40 / 7,35	8,20 / 9,57	10,0 / 10,5
	COP	Outdoor air 7 °C	Nominal	-	4,05	3,80	3,85	3,65
	Capacity	Water 18/23 °C	Nominal / Maximum	kW	4,50 / 7,84	6,50 / 9,75	8,30 / 11,4	10,0 / 12,1
	EER	Outdoor air 35 °C	Nominal	-	5,50	5,10	5,15	4,75
DHW	Capacity	Water 7/12 °C	Nominal / Maximum	kW	4,70 / 5,66	6,80 / 7,14	7,50 / 8,19	8,90 / 8,90
	EER	Outdoor air 35 °C	Nominal	-	3,65	3,10	3,45	3,25
DHW	Net tank capacity		l			143		
	Water mixed at 40 °C (V40)1		l			188		
Electrical power for meter sizing	Heating time		h:min	02:11	02:11	01:47	01:47	
			kW	2,70	3,00	3,60	3,90	
Seasonal efficiency Medium climate	Heating Water 55 °C	Energy class	-	A+++	A+++	A+++	A+++	
		Annual energy consumption	-	2.647	3.120	4.056	5.145	
		SCOP	-	3,91	3,98	4,08	4,02	
		ns (seasonal output)	%	153	156	160	158	
	Heating Water 35 °C	Energy class	-	A+++	A+++	A+++	A+++	
		Annual energy consumption	-	1.984	2.460	3.095	3.889	
		SCOP	-	5,10	5,00	5,35	5,33	
		ns (seasonal output)	%	206	199	211	210	
DHW	Energy class	-	A+	A+	A+	A+		
	Withdrawal profile	-	L	L	L	L		
Size - Indoor unit						TO		
Power supply	Voltage/Frequency/Phases		V/Hz/n °	220-240/50/1				
Expansion tank capacity			l	12				
Sound power			Nominal	dB(A)				
Sound pressure @1m			Nominal	dB(A)				
Boiler - Hybrid version						GAS BOILER FE 24.4		
Boiler	Nominal Heating capacity ((LHV)	Water 80/60 °C	Nominal	kW	24,0			
	Efficiency		Nominal	%	97,8			
Power supply	Voltage/Frequency/Phases		V/Hz/n °	220-240/50/1				
Power input	Water content		W	82				
Sound power			Nominal	dB(A)				
Size - Outdoor unit						2.1		
Power supply	Voltage/Frequency/Phases		V/Hz/n °	220-240/50/1		220-240/50/1 - 380-415/50/1		
Water flow-rate	Water 35/30 °C	Nominal	l/s	0,20	0,30	0,40	0,50	
Pump available pressure	Outdoor air 7 °C	Nominal	kPa	56	56	51	51	
Minimum system water content			l	30				
Expansion tank capacity			l	8				
Sound power			Minimum / Nominal	dB(A)		46 / 48		
Sound pressure @1m			Minimum / Nominal	dB(A)		31 / 33		
Operating range						3.1		
Water supply temperature	Heating / DHW	Full electric	Minimum / Maximum	°C				
		Hybrid	Minimum / Maximum	°C				
	Cooling	-	Minimum / Maximum	°C				
Operating Voltage Range Outdoor air	Heating / DHW	-	Minimum / Maximum	°C				
		DHW	-	Minimum / Maximum	°C			
	Cooling	-	Minimum / Maximum	°C				

Data according to EN 14511:2022 and EN 14825:2022
The Product complies with the European ErP Directive (EU Regulations 811/2013 - 813/2013 - 2016/2281). Energy classes with Control4 NRG system control

(1) Data according to EN 16147: amount of water at 40 °C with the same enthalpy content as the water coming out of the Boiler at a temperature higher than 40 °C

Dimensions and connections

Size			2.1	3.1	4.1 - 4.1T	5.1 - 5.1T
Dimensions	Indoor unit	AxCxB	mm	950x2.200x360		
	Outdoor unit	AxCxB	mm	1.330x1.051x528		
Operating weight	Indoor unit		kg	317		
	Boiler		kg	31		
	Outdoor unit		kg	150	155 - 160	
Refrigerant charge			type / GWP	R-290 / 0.02		
			kg	0,42	0,64	0,69
			CO ₂ tons	0,00002		
Indoor unit	Water (System)		inch	1"		
	Water (DHW)		inch	3/4"		
	Outdoor unit	Water (System)	inch	1" 1/4		
Boiler Hybrid version	Gas		inch	3/4"		
	Intake air		mm	80		
	Exhaust gas		mm	80		

Connection detail

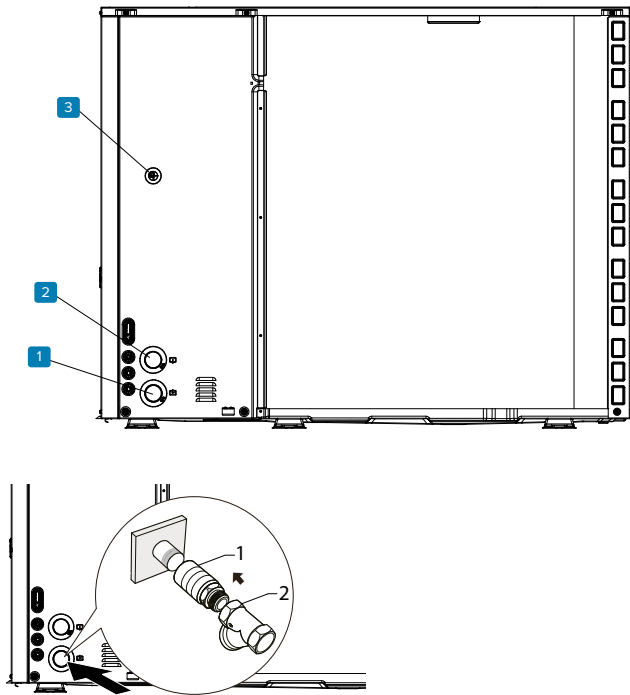

- 1 System supply 1 1/4"
- 2 System return 1 1/4"
- 3 Water side safety valve Ø 16mm

HQCN-NEE 1 IC
Indoor unit (IDU)

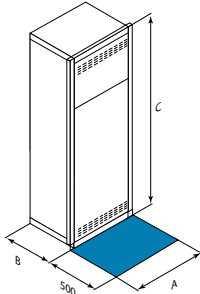

WiSAN-PMP 1 S
Outdoor unit (ODU)

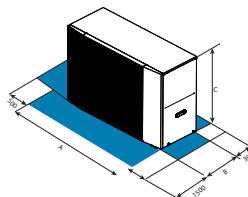

For trouble-free operation of the unit it is essential to maintain the safety distances indicated by the blue areas.

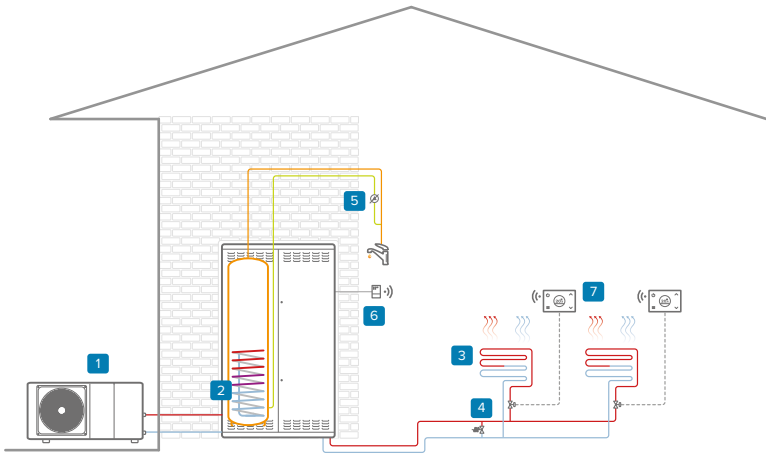

Single-zone system:
Heating / DHW

- 1 Outdoor unit
- 2 Indoor unit
- 3 Heating area
- 4 Bypass
- 5 DHW recirculation pump
- 6 Receiver / IoT switch SwitchConnect
- 7 Hid-TConnect2 chronothermostat

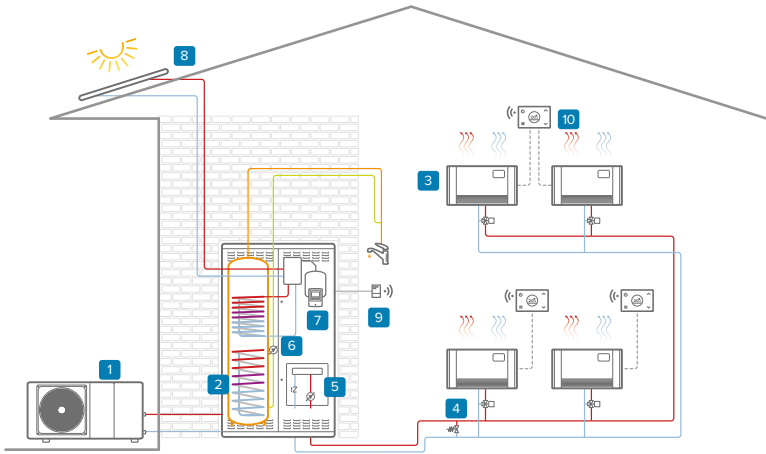

Single-zone + solar system:
Heating / DHW

- 1 Outdoor unit
- 2 Indoor unit
- 3 Cooling area
- 4 Bypass
- 5 Single zone kit circuit breaker + pump
- 6 DHW recirculation pump
- 7 Solar connection kit
- 8 ELFOSun3 thermal solar
- 9 Receiver / IoT switch SwitchConnect
- 10 Hid-TConnect2 chronothermostat

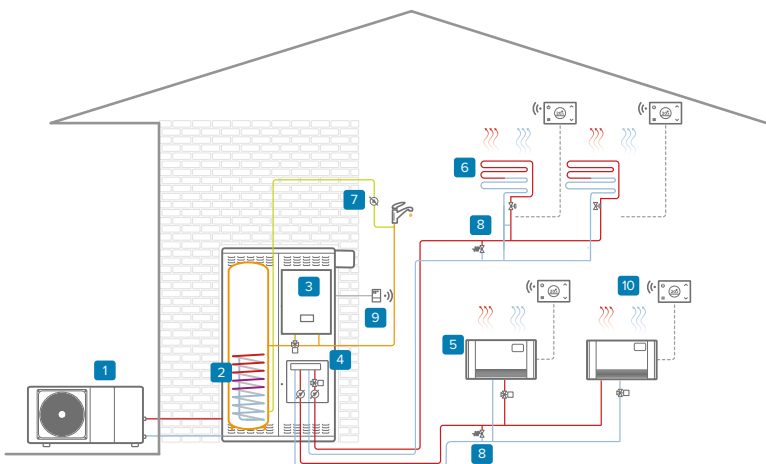

Two-zone system + boiler:
Heating / DHW

- 1 Outdoor unit
- 2 Indoor unit
- 3 Condensing boiler
- 4 Circuit breaker two-area kit + pump
- 5 Medium temperature heating system
- 6 White HID-TConnect2 chronothermostat for temperature control
- 7 Low temperature DHW recirculation pump
- 8 Bypass
- 9 Hid-TConnect2 chronothermostat Receiver / IoT switch SwitchConnect
- 10

The diagrams are for the sole purpose of illustrating the possible combinations of system elements.

*From external supply

HYDRO-SPLIT MINI

Wall-mounted indoor unit with DHW tank for Hydro-split systems



Energy saving



Solar integration (DHW tank - optional)



€-Switch

Comfort



Hot Cold



DHW



Silent

Convenience



Weekly Timer



Instant DHW (Hybrid Version)



Contemporaneity (Hybrid Version)



Integrated DHW tank

Health



Renewable Energy (Full electric version)

Management and connectivity



Input ON/ OFF



Modbus port



Control via the App



CONTROL4 NRG management



User interface/ thermostat



Clivet Eye monitoring

RELIABILITY



Backup heater (optional)



- ✓ 50 l DHW storage tank
- ✓ Complete unit
- ✓ Integrated hydraulic separator
- ✓ Can be combined with EDGE outdoor units
- ✓ Reduced space requirements
- ✓ Easy installation

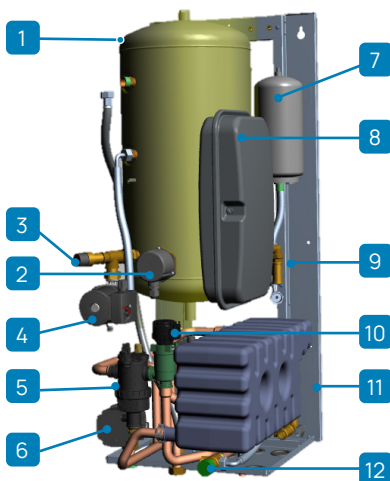

- 1 50-litre domestic water tank
- 2 Backup electric heater
- 3 System pressure relief valve
- 4 Domestic water circuit circulator
- 5 Magnetic deflector filter+safety valve
- 6 Hydraulic separator with secondary pump
- 7 Health expansion tank
- 8 System expansion tank
- 9 Health safety valve
- 10 Inertial tank
- 11 3-way valve for DHW
- 12 Anti-scalding valve

HEAT PUMPS

Configurations

CONTROL:

- HMIR32 Can be combined with EDGE EVO 2.0
- HMIR290 Can be combined with EDGE F and EDGE PRO

System diagrams

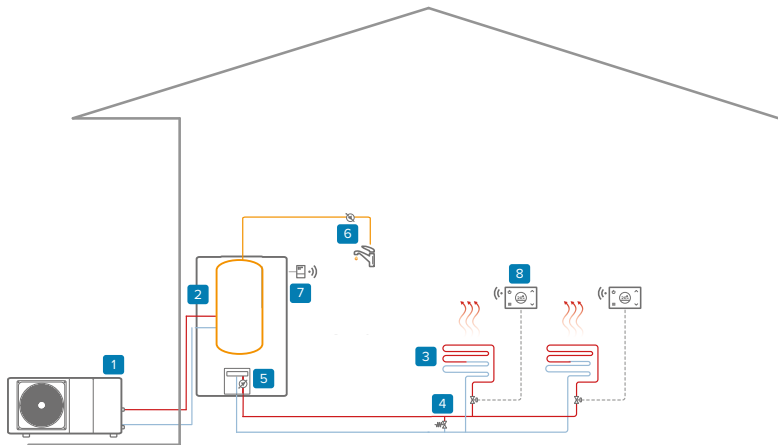

Single booster single-area system:
Heating / DHW

- 1 Outdoor unit
- 2 Indoor unit
- 3 Heating area
- 4 Bypass*
- 5 Hydraulic separator single-area kit plus pump
- 6 DHW recirculation pump
- 7 SwitchConnect Wi-Fi receiver
HiDTConnect2 Wi-Fi chronothermostat

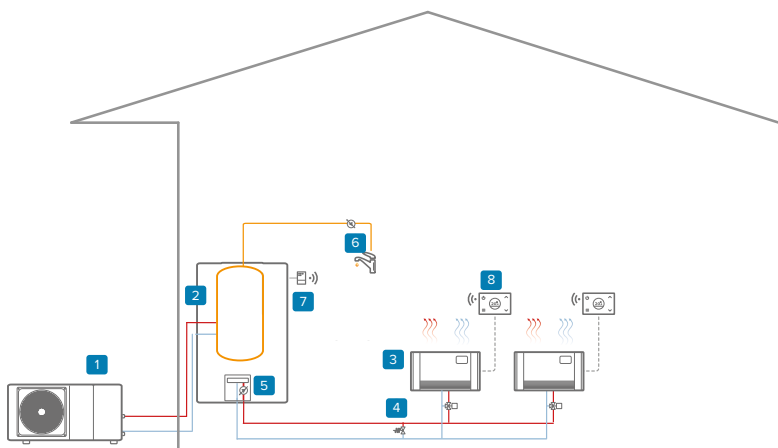

Single booster single-area system:
Heating / DHW

- 1 Outdoor unit
- 2 Indoor unit
- 3 Heating area
- 4 Bypass*
- 5 Hydraulic separator single-area kit plus pump
- 6 DHW recirculation pump
- 7 SwitchConnect Wi-Fi receiver
HiDTConnect2 Wi-Fi chronothermostat

The diagrams are for the sole purpose of illustrating the possible combinations of system elements.

*From external supply

Technical data - MINI version+ EDGE EVO 2.0

Size - Set				2.1	3.1	4.1	5.1	6.1 - 6.1T	7.1 - 7.1T	8.1 - 8.1T	
Heating	Capacity	Water 35/30°C	Nominal / Maximum	kW	4,20 / 6,26	6,35 / 7,41	8,40 / 9,11	10,0 / 10,3	12,1 / 14,6	14,5 / 15,5	15,9 / 16,8
	COP	Outdoor air 7°C	Nominal	-	5,10	4,95	5,15	4,95	4,95	4,60	4,50
	Capacity	Water 35/30°C	Nominal / Maximum	kW	4,70 / 4,99	6,00 / 6,21	7,00 / 7,27	8,00 / 8,31	10,0 / 11,0	12,0 / 12,7	13,1 / 13,9
	COP	Outdoor air -7°C	Nominal	-	3,10	3,00	3,20	3,05	3,00	2,85	2,70
Cooling	Capacity	Water 45/40°C	Nominal / Maximum	kW	4,30 / 5,96	6,30 / 7,13	8,10 / 8,98	10,0 / 10,3	12,3 / 14,5	14,1 / 15,7	16,0 / 16,6
	COP	Outdoor air 7°C	Nominal	-	3,80	3,70	3,85	3,75	3,70	3,60	3,50
	Capacity	Water 18/23°C	Nominal / Maximum	kW	4,50 / 7,65	6,50 / 7,65	8,30 / 11,1	9,90 / 12,0	12,0 / 15,0	13,5 / 15,3	14,2 / 16,4
	EER	Outdoor air 35°C	Nominal	-	5,50	4,80	5,05	4,55	3,95	3,61	3,61
DHW	Capacity	Water 7/12°C	Nominal / Maximum	kW	4,70 / 6,14	7,00 / 7,11	7,45 / 7,94	8,20 / 8,67	11,5 / 11,5	12,4 / 12,4	14,0 / 14,0
	EER	Outdoor air 35°C	Nominal	-	3,45	3,00	3,35	3,25	2,75	2,50	2,50
DHW	Net tank capacity			l				50			
	Water mixed at 40°C (V40)			l				62			
Electrical power for meter sizing	Heating time			h:min	00:55	00:55	00:42	00:42		00:36	
				kW	2,30	2,70	3,40	3,70	5,50	5,80	6,20
Seasonal efficiency Medium climate	Heating Water 55°C	Energy class		-	A++	A++	A++	A++	A++	A++	A++
		Annual energy consumption		-	2.749	3.348	4.064	4.541	6.916	6.917	7.213
	ns (seasonal output)	SCOP		-	3,31	3,52	3,37	3,47	3,45	3,47	3,41
		%		%	129	138	131	137	135	135	133
	Heating Water 35°C	Energy class		-	A+++	A+++	A+++	A+++	A+++	A+++	A+++
		Annual energy consumption		-	2.354	2.849	3.223	3.649	5.156	5.157	6.011
ns (seasonal output)	SCOP		-	4,85	4,95	5,22	5,20	4,81	4,72	4,62	
	%		%	191	195	205	205	189	186	182	
Energy class			-	A+	A+	A+	A+	A+	A+	A+	
Withdrawal profile			-	L	L	L	L	L	L	L	
Size - Indoor unit				TO							
Power supply	Voltage/Frequency/Phases		V/Hz/n°	220-240/50/1							
System expansion tank capacity			l	8							
DHW expansion tank capacity			l	3							
Sound power	Nominal		dB(A)	41							
Sound pressure @1m	Nominal		dB(A)	26							
Size - Outdoor unit				2.1	3.1	4.1	5.1	6.1 - 6.1T	7.1 - 7.1T	8.1 - 8.1T	
Power supply	Voltage/Frequency/Phases		V/Hz/n°	220-240/50/1							
Water flow-rate	Water 35/30°C	Nominal	l/s	0,20	0,30	0,40	0,48	0,58	0,69	0,76	
Pump available pressure	Outdoor air 7°C	Nominal	kPa	85	84	80	71	60	48	40	
Expansion tank capacity			l	30							
Minimum system water content			l	4,8							
Sound power	Minimum / Nominal		dB(A)	53 / 55	55 / 58	54 / 59	55 / 60	59 / 65	59 / 65	59 / 68	
Sound pressure @1m	Nominal		dB(A)	45	47	48	50	53	53	57	
Operating range											
Water supply temperature	Heating / DHW	Full electric	Minimum / Maximum	°C							
		Hybrid	Minimum / Maximum	°C							
Operating Voltage Range	Heating / DHW	-	Minimum / Maximum	°C							
		-	Minimum / Maximum	°C							
Outdoor air	Cooling	-	Minimum / Maximum	°C							
		-	Minimum / Maximum	°C							

Data according to EN 14511:2022 and EN 14825:2022
The Product complies with the European ErP Directive (EU Regulations 811/2013 - 813/2013 - 2016/2281). Energy classes with Control4 NRG system control

(1) Data according to EN 16147: amount of water at 40 °C with the same enthalpy content as the water coming out of the Boiler at a temperature higher than 40 °C

Dimensions and connections

Size				2.1	3.1	4.1	5.1	6.1 - 6.1T	7.1 - 7.1T	8.1 - 8.1T
Indoor unit	AxCxB	mm		450 x 1100 x 550						
	AxCxB	mm		1.295x717x400						
Operating weight	Indoor unit	kg		140						
	Outdoor unit	kg		86		105			129	
Refrigerant charge	type / GWP	kg		R-32 / 675						
		CO ₂ tons		1,40						
				0,95						
External diameters	Indoor unit	Water (System)	inch	1"						
		Water (DHW)	inch	3/4"						
	Outdoor unit	Water (System)	inch	1"	1" 1/4					

Connection detail

SIZES 2.1 to 3.1

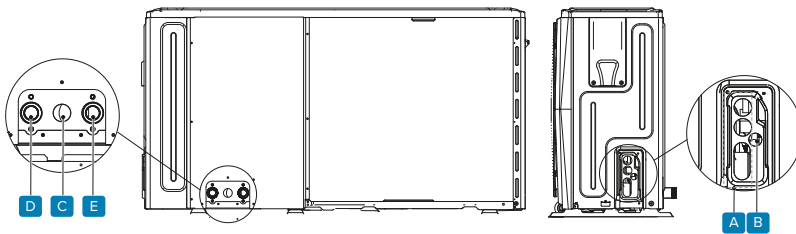

SIZES 4.1 to 8.1

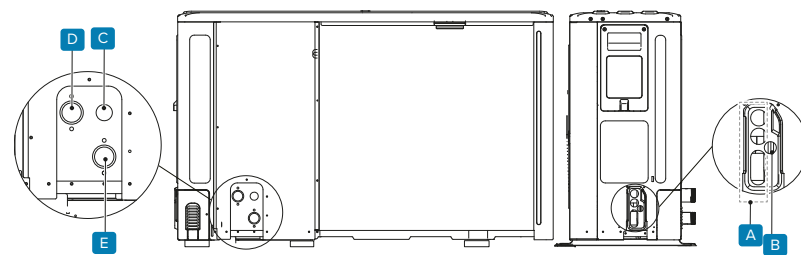

- 1 Hole for high voltage cable (power supply)
- 2 Hole for low pressure cable (control and signal cables)
- 3 Hole for discharge pipe
- 3 Water outlet
- 4 Water inlet
- 5

HQCN-NEE 1 MC A

Indoor unit (IDU)

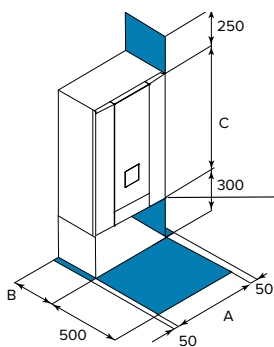

WiSAN-YME 1 S

Outdoor unit (ODU)

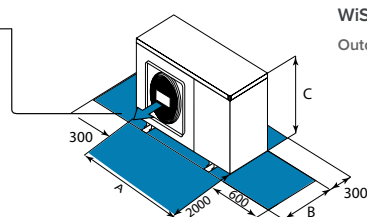

For trouble-free operation of the unit it is essential to maintain the safety distances indicated by the blue areas.

Technical data - MINI version + EDGE F

Size - Set				2.1	3.1	4.1	5.1	6.1 - 6.1T	7.1 - 7.1T	8.1 - 8.1T	
Heating	Capacity	Water 35/30°C	Nominal / Maximum	kW	4,50 / 6,86	6,20 / 7,70	8,40 / 0,4	10,0 / 11,0	12,0 / 14,7	14,0 / 16,0	15,0 / 17,6
	COP	Outdoor air 7°C	Nominal	-	5,15	4,90	5,00	4,70	4,80	4,50	4,40
	Capacity	Water 35/30°C	Nominal / Maximum	kW	4,50 / 5,56	5,90 / 6,18	7,00 / 8,74	8,00 / 8,89	10,0 / 11,1	11,5 / 12,1	12,7 / 13,2
	COP	Outdoor air -7°C	Nominal	-	3,10	2,95	3,00	2,85	2,80	2,70	2,50
Cooling	Capacity	Water 45/40°C	Nominal / Maximum	kW	4,50 / 6,55	6,40 / 7,35	8,20 / 9,57	10,0 / 10,5	12,0 / 14,1	14,0 / 15,3	15,0 / 16,9
	COP	Outdoor air 7°C	Nominal	-	4,05	3,80	3,85	3,65	3,70	3,50	3,35
	Capacity	Water 18/23°C	Nominal / Maximum	kW	4,50 / 7,84	6,50 / 9,75	8,30 / 11,4	10,0 / 12,1	12,0 / 16,4	14,0 / 17,3	16,0 / 18,6
	EER	Outdoor air 35°C	Nominal	-	5,50	5,10	5,15	4,75	4,50	4,20	3,90
DHW	Capacity	Water 7/12°C	Nominal / Maximum	kW	4,70 / 5,66	6,80 / 7,14	7,50 / 8,19	8,90 / 8,90	11,5 / 12,0	12,7 / 12,7	14,0 / 14,3
	EER	Outdoor air 35°C	Nominal	-	3,65	3,10	3,45	3,25	3,05	2,90	2,75
	Net tank capacity			l	50	50	50	50	50	50	50
	Water mixed at 40°C (V40)			l	62	62	62	62	62	62	62
	Heating time			h:min	00:39	00:39	00:29	00:29	00:23	00:23	00:23
Electrical power for meter sizing				kW	2,70	3,00	3,60	3,90	6,00	6,00	6,40
Seasonal efficiency Medium climate	Energy class			-	A++	A++	A++	A++	A++	A++	A++
	Annual energy consumption			-	2.684	3.164	3.676	4.215	6.847	7.414	8.349
	SCOP			-	3,79	3,81	3,81	3,82	3,62	3,62	3,57
	ns (seasonal output)			%	148,7	149,7	149,7	149,8	141,8	141,9	139,9
	Energy class			-	A+++	A+++	A+++	A+++	A+++	A+++	A+++
	Annual energy consumption			-	2.040	2.692	3.187	3.734	5.376	6.091	6.630
	SCOP			-	5,09	4,91	5,20	5,07	4,68	4,64	4,59
	ns (seasonal output)			%	200,7	193,5	204,8	199,8	184,0	182,4	180,6
Size - Indoor unit					A	A	A	A	A	A	
Power supply		Voltage/Frequency/Phases		V/Hz/n°	220-240/50/1						
System expansion tank capacity				l	8	8	8	8	8	8	
DHW expansion tank capacity				l	3	3	3	3	3	3	
Sound power		Nominal		dB(A)	41	41	41	41	41	41	
Sound pressure @1m		Nominal		dB(A)	26	26	26	26	26	26	
Size - Outdoor unit					2.1	3.1	4.1	5.1	6.1 - 6.1T	7.1 - 7.1T	8.1 - 8.1T
Power supply		Voltage/Frequency/Phases		V/Hz/n°	220-240/50/1			220-240/50/1 - 380-415/50/3+N			
Water flow-rate		Water 35/30°C	Nominal	l/s	0,21	0,30	0,40	0,48	0,57	0,67	0,71
Pump available pressure		Outdoor air 7°C	Nominal	kPa	89	87	80	71	63	54	49
Expansion tank capacity				l	8	8	8	8	8	8	
Minimum system water content				l	30	30	40	40	40	40	
Sound power		Minimum / Nominal		dB(A)	51 / 56	53 / 58	55 / 60	56 / 61	58 / 65	59 / 65	60 / 69
Sound pressure @1m		Minimum / Nominal		dB(A)	40 / 44	42 / 46	42 / 48	43 / 49	43 / 51	44 / 52	48 / 56
Operating range											
Water supply temperature	Heating / DHW	Full electric	Minimum / Maximum	°C	25 / 75						
		Hybrid	Minimum / Maximum	°C	25 / 75						
	Cooling	-	Minimum / Maximum	°C	5 / 25						
Operating Voltage Range	Heating	-	Minimum / Maximum	°C	-25 / 35						
	DHW	-	Minimum / Maximum	°C	-25 / 43						
Outdoor air	Cooling	-	Minimum / Maximum	°C	-5 / 43						

Data according to EN 14511:2022 and EN 14825:2022
The Product complies with the European ErP Directive (EU Regulations 811/2013 - 813/2013 - 2016/2281). Energy classes with Control4 NRG system control

(1) Data according to EN 16147: amount of water at 40 °C with the same enthalpy content as the water coming out of the Boiler at a temperature higher than 40 °C

Dimensions and connections

Size				2.1	3.1	4.1	5.1	6.1	7.1	8.1	
Dimensions	Indoor unit	AxCxB	mm	450 x 1100 x 550							
	Outdoor unit	AxCxB	mm	1.295x718x386		1.385x865x423					
Operating weight	Indoor unit		kg	130							
	Outdoor unit		kg	90	117				135		
Refrigerant charge			type / GWP	R-290 / 0.02							
			kg	0,70	1,10				1,25		
			CO ₂ tons	0,002	0,003				0,004		
External diameters	Indoor unit	Water (System)	inch	1"							
		Water (DHW)	inch	3/4"							
	Outdoor unit	Water (System)	inch	1"	1" 1/4						

Connection detail

SIZES 2.1 to 3.1

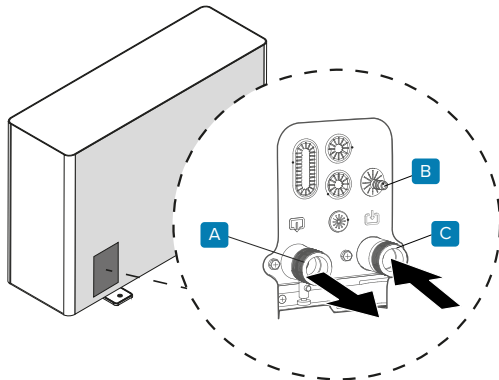

- A** 1" system supply
- B** Pressure relief valve Ø 16 mm
- C** 1" system return

SIZES 4.1 to 8.1

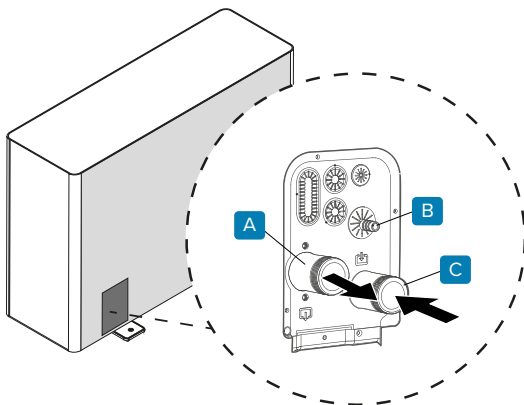

- A** System supply 1 1/4"
- B** Pressure relief valve Ø 16 mm
- C** System return 1 1/4"

HQCN-NEE 1 MC A

Indoor unit (IDU)

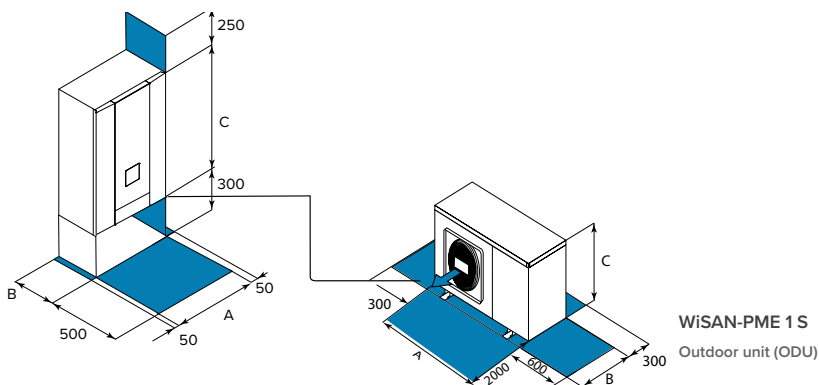

For trouble-free operation of the unit it is essential to maintain the safety distances indicated by the blue areas.

Technical data - MINI version + EDGE PRO

HEAT PUMPS

Size - Set				2.1	3.1	4.1	5.1	6.1 - 6.1T	7.1 - 7.1T	8.1 - 8.1T	
Heating	Capacity	Water 35/30°C	Nominal / Maximum	kW	4,10 / 7,72	6,10 / 8,99	8,00 / 11,6	9,50 / 12,6	12,1 / 15,0	14,0 / 16,3	15,5 / 17,7
	COP	Outdoor air 7°C	Nominal	-	5,30	5,03	5,25	4,95	4,95	4,70	4,50
	Capacity	Water 35/30°C	Nominal / Maximum	kW	4,10 / 6,70	6,00 / 7,63	7,00 / 9,12	8,00 / 9,64	10,0 / 12,4	12,0 / 14,6	13,1 / 15,7
	COP	Outdoor air -7°C	Nominal	-	3,25	3,03	3,25	3,15	3,15	2,80	2,70
	Capacity	Water 45/40°C	Nominal / Maximum	kW	4,50 / 7,27	6,40 / 8,51	8,10 / 11,0	9,50 / 12,2	12,3 / 14,5	14,1 / 16,0	15,5 / 17,3
	COP	Outdoor air 7°C	Nominal	-	4,17	3,91	4,00	3,90	3,90	3,75	3,65
Cooling	Capacity	Water 18/23°C	Nominal / Maximum	kW	4,50 / 8,36	6,50 / 10,8	8,30 / 11,0	10,0 / 11,9	12,0 / 17,1	14,0 / 18,2	16,0 / 18,9
	EER	Outdoor air 35°C	Nominal	-	5,65	5,51	5,25	4,60	4,60	4,40	4,25
	Capacity	Water 7/12°C	Nominal / Maximum	kW	4,70 / 6,96	6,80 / 9,03	7,50 / 9,19	8,10 / 9,90	11,5 / 13,9	12,4 / 14,9	14,0 / 16,7
	EER	Outdoor air 35°C	Nominal	-	3,65	3,10	3,35	3,10	3,05	3,00	2,70
DHW	Net tank capacity			l	50	50	50	50	50	50	
	Water mixed at 40°C (V40)			l	62	62	62	62	62	62	
	Heating time			h:min	00:39	00:39	00:29	00:29	00:23	00:23	00:23
Electrical power for meter sizing				kW	2,70	3,00	3,90	4,20	5,90	6,30	6,70
Seasonal efficiency Medium climate	Energy class			-	A+++	A+++	A+++	A+++	A+++	A+++	A+++
	Heating Water 55°C	Annual energy consumption	-	2,647	3,120	4,056	5,145	6,266	7,479	8,013	
		SCOP	-	3,91	3,98	4,08	4,02	3,96	3,87	3,87	
	ns (seasonal output)		%	153	156	160	158	155	152	152	
		Energy class	-	A+++	A+++	A+++	A+++	A+++	A+++	A+++	
	Heating Water 35°C	Annual energy consumption	-	1,984	2,460	3,095	3,889	5,014	6,069	7,009	
		SCOP	-	5,10	5,00	5,35	5,33	4,94	4,76	4,72	
	ns (seasonal output)		%	206	199	211	210	195	188	186	
					TO	TO	TO	TO	TO	TO	TO
Size - Indoor unit											
Power supply		Voltage/Frequency/Phases		V/Hz/n°	220-240/50/1						
System expansion tank capacity				l	8	8	8	8	8	8	
DHW expansion tank capacity				l	3	3	3	3	3	3	
Sound power		Nominal		dB(A)	41	41	41	41	41	41	
Sound pressure @1m		Nominal		dB(A)	26	26	26	26	26	26	
Size - Outdoor unit					2.1	3.1	4.1	5.1	6.1 - 6.1T	7.1 - 7.1T	8.1 - 8.1T
Power supply		Voltage/Frequency/Phases		V/Hz/n°	220-240/50/1			220-240/50/1 - 380-415/50/3+N			
Water flow-rate		Water 35/30°C Nominal		l/s	0,20	0,30	0,40	0,50	0,60	0,70	0,70
Pump available pressure		Outdoor air 7°C Nominal		kPa	56	56	51	51	45	42	38
Minimum system water content				l	40						
Sound power		Minimum / Nominal		dB(A)	46 / 48	46 / 50	47 / 52	47 / 52	48 / 52	48 / 55	48 / 56
Sound pressure @1m		Minimum / Nominal		dB(A)	31 / 33	32 / 34	33 / 35	35 / 37	38 / 37	38 / 40	39 / 41
Operating range											
Water supply temperature	Heating / DHW	Full electric	Minimum / Maximum	°C	25 / 75						
		Hybrid	Minimum / Maximum	°C	25 / 75						
Operating Voltage Range	Cooling	-	Minimum / Maximum	°C	5 / 25						
		-	Minimum / Maximum	°C	-25 / 35						
Outdoor air	Cooling	-	Minimum / Maximum	°C	-25 / 43						
		-	Minimum / Maximum	°C	-5 / 43						

Data according to EN 14511:2022 and EN 14825:2022
The Product complies with the European ErP Directive (EU Regulations 811/2013 - 813/2013 - 2016/2281). Energy classes with Control4 NRG system control

(1) Data according to EN 16147: amount of water at 40 °C with the same enthalpy content as the water coming out of the Boiler at a temperature higher than 40 °C

Dimensions and connections

Size				2.1	3.1	4.1	5.1	6.1 - 6.1T	7.1 - 7.1T	8.1 - 8.1T
Dimensions	Indoor unit	AxCxB	mm	450 x 1100 x 550						
	Outdoor unit	AxCxB	mm	1.330x1.051x528						
Operating weight	Indoor unit		kg	130						
	Outdoor unit		kg	150	155 - 160		175 - 180			
Refrigerant charge		type / GWP		R-290 / 0.02						
			kg	0,42	0,64		0,69	0,89	1,00	1,08
			CO ₂ tons	0,002						
External diameters	Indoor unit	Water (System)	inch	1"						
		Water (DHW)	inch	3/4"						
	Outdoor unit	Water (System)	inch	1" 1/4"						

Connection detail

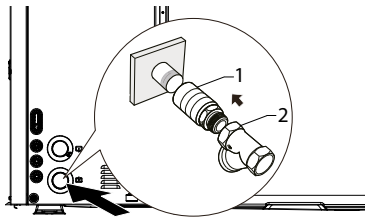
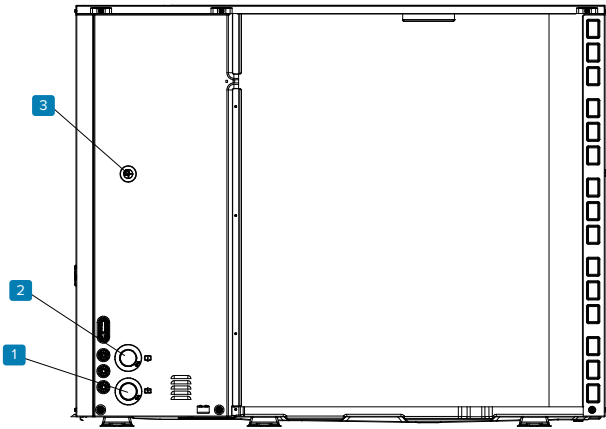

- 1 System supply 1 1/4"
- 2 System return 1 1/4"
- 3 Water side safety valve Ø 16mm

HQCN-NEE 1 MC A

Indoor unit (IDU)

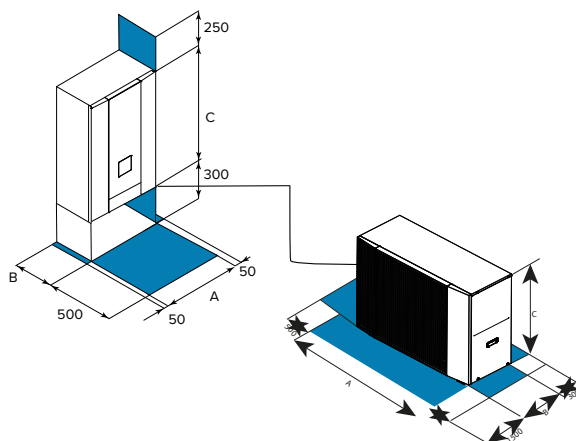

WiSAN PMP 1 S
Outdoor unit (ODU)

For trouble-free operation of the unit it is essential to maintain the safety distances indicated by the blue areas.

Accessory products for heat pumps



2.1 Heat pumps



Boiler

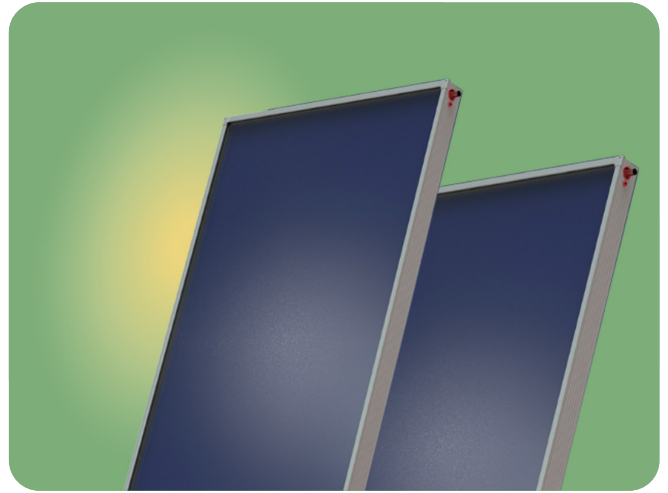

ELFOSUN3

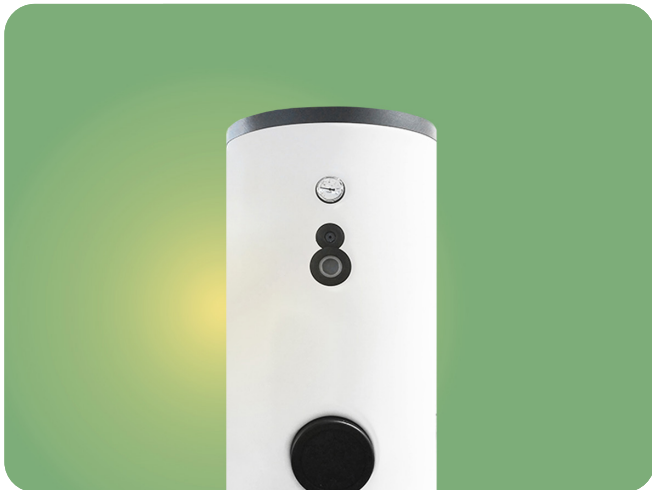

DWH boilers

GAS BOILER FE 24.4-33.4

Instantaneous wall-mounted condensing boiler for stand-alone systems



Comfort



DHW



High temperature

Convenience



Instant DHW

Management and connectivity







Input ON/
OFF

The €/Switch function

Factory made hybrids have a function that can be selected directly from the interface, which makes it possible to calculate the resource (heat pump and/or boiler) that is able to fulfil the heat demand with the lowest economic cost in every operating condition. To use the €-Switch function, simply enter the cost per kWh of electricity and the cost per m³ of methane gas from the energy provider's supply contract, and define the main type of terminals in the building (radiant panel, fan coil, radiator)

Accessories

	KCSAFX	Vertical coaxial fitting for smoke intake and discharge (d. 60/100 mm)		KSDFX	Splitter for suction and flue gas discharge (d. 80/80 mm)
	CCOAX	90° coaxial curve for suction and flue gas discharge, 360° adjustable (d. 60/100 mm)		KISX	Kit di installazione semplificata con raccordi per SPHERA EVO 2.0 Box Hybrid
	TCOAX	1 m coaxial pipe with terminal (d. 60/100 mm)			









GAS BOILER UC 33.4÷200F.2

Instantaneous wall-mounted condensing boiler (33,4)
 Wall-mounted condensing boiler for heating only (70.2-115.2)
 Floor-standing condensing boiler for heating only (200F.2)



- ✓ Dedicated versions for stand-alone and centralised systems
- ✓ Heat pump stand-by / replacement / back-up operation
- ✓ Management with ON/OFF signal and 0-10V signal
- ✓ LPG or methane supply
- ✓ Instant DHW production

Accessories

	KCSAFX	Vertical coaxial fitting for smoke intake and discharge (d. 60/100 mm) (Gas Boiler UC 33.4)		INAILX	Safety kit for single gas boiler installation (Gas Boiler UC 70.2-115.2-200F.2)
	CCOAX	90° coaxial curve for suction and flue gas discharge, 360° adjustable (d. 60/100 mm) (Gas Boiler UC 33.4)		FH100X	Vertical flue gas discharge terminal (d. 100 mm) (Gas Boiler UC 115.2- 200F.2)
	TCOAX	1 m coaxial pipe with terminal (d. 60/100 mm)		HIDUCX	Remote control for boilers (Gas Boiler UC 70.2-115.2)
	KAS80X (to exhaustion)	Fittings for suction and flue gas discharge (2 x d. 80 mm) (Gas Boiler UC 33.4)		KISX	Kit di installazione semplificata con raccordi per SPHERA EVO 2.0 Box Hybrid

Technical data

Size				FE 24.4	FE 33.4	UC 34.4	UC 70.2	UC 115.2	UC 200F.2	
Heating	Heating capacity (Pn) P.C.I.	Water 80/60°C	Water content	kW	24,0	34,0	33,2	67,5	115,0	199,0
			Minimum	kW	4,70	4,90	4,80	9,10	20,0	19,1
		Water 50/30°C	Water content	kW	26,0	37,0	35,8	68,7	120,3	205,2
			Minimum	kW	5,20	5,40	5,40	10,3	21,4	21,1
	Efficiency	Water 80/60°C	Maximum	%	97,8	97,7	97,7	97,3	97,3	97,9
			Minimum	%	97,6	97,2	96,4	94,9	95,9	95,6
		Water 50/30°C	Maximum	%	106,1	106,2	105,2	101,7	104,3	103,1
			Minimum	%	107,3	107,1	107,0	107,6	107,1	105,4
30% di Pn	-	%	109,7	109,7	108,6	107,3	107,2	108,9		
DHW	Nominal heating capacity (Qnw)	Maximum	kW	28,5	34,8	34,0	-	-	-	
		Minimum	kW	4,70	5,00	5,00	-	-	-	
	Specific flow rate	ΔT=30 °C in 10 minutes	l/min	13,4	16,2	15,8	-	-	-	
		ΔT=25 °C in 10 minutes	l/min	16,1	19,5	19,0	-	-	-	
Seasonal efficiency Medium climate	Heating	Energy class	-	A	A	A	A	A	A	
		ns (seasonal output)	%	94	94	93	93	92	93	
	DHW	Energy class	-	A	A	A	-	-	-	
		Withdrawal profile	-	XL	XXL	XL	-	-	-	
nwh	%	85	85	90	-	-	-			

Technical specifications

Type	-	instantaneous	only heating
Installation	-	wall-mounted	floor-standing
Power supply	Voltage/Frequency/Phases	V/Hz/n°	230/50/1
Expansion tank capacity		l	8 10 -
Power input	Water content	W	82 99 122 267 314 580
Sound power	Nominal	dB(A)	49 52 56 63 - -

Operating range

Water supply temperature	Heating	Minimum / Maximum	°C	20 / 95	15 / 85	20 / 85
	DHW	Minimum / Maximum	°C	40 / 65	-	-
Operating Voltage Range Outdoor air	Heating / DHW	Minimum / Maximum	°C	-5* / 50	-	-

* with antifreeze kit down to -15°C

Dimensions and connections

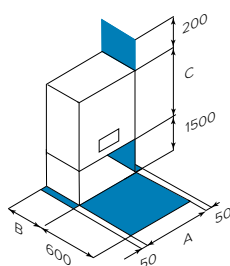

FE Version

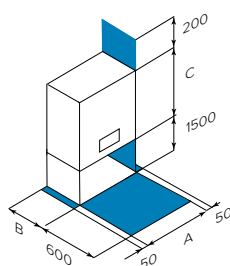

UC 24.4-115.2 Version

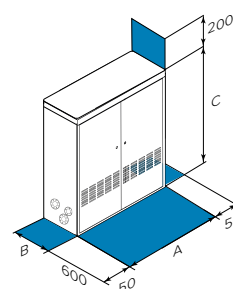

UC 200F.2

Size			FE 24.4	FE 33.4	UC 34.4	UC 70.2	UC 115.2	UC 200F.2
Dimensions	AxCxB	mm	420x700x250	420x700x320	420x700x345	615x930x266	500x950x500	950x1.214x606
Weight		kg	27	31	40	58,4	81	316
	Water (System)	inch		3/4"			1 1/4"	3 1/2"
	Water (DHW)	inch		1/2"			-	
External diameters	Gas	inch		3/4"			1"	2"
	Intake air	mm			80	80		
	Exhaust gas	mm						100

“Factory made” hybrid combinations

Combination	Size	Hybrid “Factory made”					
		24.4	33.4	70.2	115.2	200F.2	
1 unit	2.1	√	√	√	√	√	
	3.1	√	√	√	√	√	
	4.1	√	√	√	√	√	
	5.1	√	√	√	√	√	
	6.1	-	√	√	√	√	
	7.1	-	√	√	√	√	
	8.1	-	√	√	√	√	
	9.1	-	-	√	√	√	
	10.1	-	-	√	√	√	
	12.1	-	-	√	√	√	
	14.1	-	-	√	√	√	
	2 unit (cascade)	2.1+2.1	√	√	√	√	√
		3.1+3.1	-	√	√	√	√
		4.1+4.1	-	√	√	√	√
5.1+5.1		-	-	√	√	√	
6.1+6.1		-	-	√	√	√	
7.1+7.1		-	-	√	√	√	
8.1+8.1		-	-	√	√	√	
9.1+9.1		-	-	-	√	√	
10.1+10.1		-	-	-	√	√	
12.1+12.1		-	-	-	√	√	
14.1+14.1		-	-	-	-	√	
3 unit (cascade)		2.1+2.1+2.1	-	√	√	√	√
		3.1+3.1+3.1	-	-	√	√	√
		4.1+4.1+4.1	-	-	√	√	√
	5.1+5.1+5.1	-	-	√	√	√	
	6.1+6.1+6.1	-	-	-	√	√	
	7.1+7.1+7.1	-	-	-	√	√	
	8.1+8.1+8.1	-	-	-	√	√	
	9.1+9.1+9.1	-	-	-	√	√	
	10.1+10.1+10.1	-	-	-	-	√	
	12.1+12.1+12.1	-	-	-	-	√	
	14.1+14.1+14.1	-	-	-	-	√	
	4 unit (cascade)	2.1+2.1+2.1+2.1	-	-	√	√	√
		3.1+3.1+3.1+3.1	-	-	√	√	√
		4.1+4.1+4.1+4.1	-	-	-	√	√
5.1+5.1+5.1+5.1		-	-	-	√	√	
6.1+6.1+6.1+6.1		-	-	-	√	√	
7.1+7.1+7.1+7.1		-	-	-	-	√	
8.1+8.1+8.1+8.1		-	-	-	-	√	
9.1+9.1+9.1+9.1		-	-	-	-	√	
10.1+10.1+10.1+10.1		-	-	-	-	√	
5 unit (cascade)		2.1+2.1+2.1+2.1+2.1	-	-	√	√	√
		3.1+3.1+3.1+3.1+3.1	-	-	√	√	√
		4.1+4.1+4.1+4.1+4.1	-	-	-	√	√
		5.1+5.1+5.1+5.1+5.1	-	-	-	√	√
		6.1+6.1+6.1+6.1+6.1	-	-	-	-	√
	7.1+7.1+7.1+7.1+7.1	-	-	-	-	√	
	8.1+8.1+8.1+8.1+8.1	-	-	-	-	√	
	9.1+9.1+9.1+9.1+9.1	-	-	-	-	√	
	6 unit (cascade)	2.1+2.1+2.1+2.1+2.1+2.1	-	-	√	√	√
		3.1+3.1+3.1+3.1+3.1+3.1	-	-	-	√	√
		4.1+4.1+4.1+4.1+4.1+4.1	-	-	-	√	√
		5.1+5.1+5.1+5.1+5.1+5.1	-	-	-	-	√
		6.1+6.1+6.1+6.1+6.1+6.1	-	-	-	-	√
		7.1+7.1+7.1+7.1+7.1+7.1	-	-	-	-	√

ELFOSUN3

Flat-plate solar thermal collector for combination with domestic hot water production systems

HEAT PUMPS

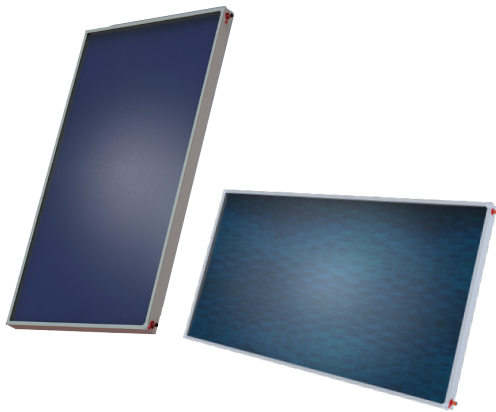

Reliability



031

Health



Renewable Energy

- ✓ It uses renewable energy and contributes greatly to the increase in the building's energy class
- ✓ It can be combined in series and is ideal for empty and pressurised systems
- ✓ One of the most efficient solutions on the market
- ✓ Installation with specific kit for either a pitched or flat roof or uncased in the roof
- ✓ Tempered prismatic glass surface to capture maximum sunlight and resist weathering

Dimensions and connections

F-L / F-XL: up to 5 panels can be connected in parallel



FH-XL: up to 3 panels can be connected in parallel





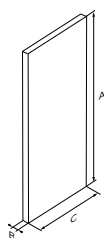



Note: refer to the specific documentation to connect several panels



			F-L	F-XL	FH-XL
Dimensions	AxCxB	mm	1.980x1.010x86	1.930x1.230x86	1.230x1.930x86
Weight		kg	34		42
External diameters		mm		22 (x4)	

Accessories

	KFSX	Fixing kit on pitched or flat roofs for 1 vertical solar panel (per F-L / F-XL)
	KFDX	Fixing kit on pitched or flat roofs for 2 vertical solar panels (per F-L / F-XL)
	KFPX	Fixing kit on flat roofs for 1 horizontal solar panel (per FH-XL)
	KFP2X	Fixing kit on flat roofs for 2 horizontal solar panels (per FH-XL)
	KFIX	Sloping roof fixing kit for 1 horizontal collector (for FH-XL)
	KFI2X	Sloping roof fixing kit for 2 horizontal collectors (for FH-XL)
	KFIN1X	Uncased fixing kit for 1 vertical collector (for F-L / F-XL)
	KFIN2X	Uncased fixing kit for 2 vertical collectors (for F-L / F-XL)
	KCIX	Connection kit for intermediate connection between solar collectors
	KCCX	Kit for single-column circulation, solar control unit and 3/4" non return valve
	KCCBX	Kit for two-column circulation, solar control unit and 3/4" non return valve
	VE18X	18 liter expansion vessel
	VE25X	25 liter expansion vessel
	VE40X	40 liter expansion vessel
	VMTX	Thermostatic mixing valve
	GP10X	10 liter tank of concentrated propylene glycol

Technical data

Model			F-L	F-XL	FH-XL
Installation	Type	-		vert.	horiz.
	no. (in parallel) Maximum	-		5	3
Surface	gross	m ²	2,00		2,37
	opening	m ²	1,86		2,23
Peak capacity		W	1.522		1.804
Technical specifications					
Performances	nCOL - collector efficiency	%		60	
	n0 - zero-loss collector efficiency	-		0,761	
	a1 - heat loss coefficient	W/m ² K		3,60	
	a2 - Temperature / heat loss coefficient ratio	W/m ² K ²		0,014	
Stagnant temperature		°C		190	
Operating pressure	Water content	bar		10	
Panel water flow		l	1,42	1,71	2,16
Panel water flow	Nominal	l/min/m ²	1,6÷2		2÷2,7
Absorptance		%		≥ 95	

The Product complies with the European ErP Directive (UE Regulations 811/2013 - 813/2013)

(1) Control unit for indoor installation

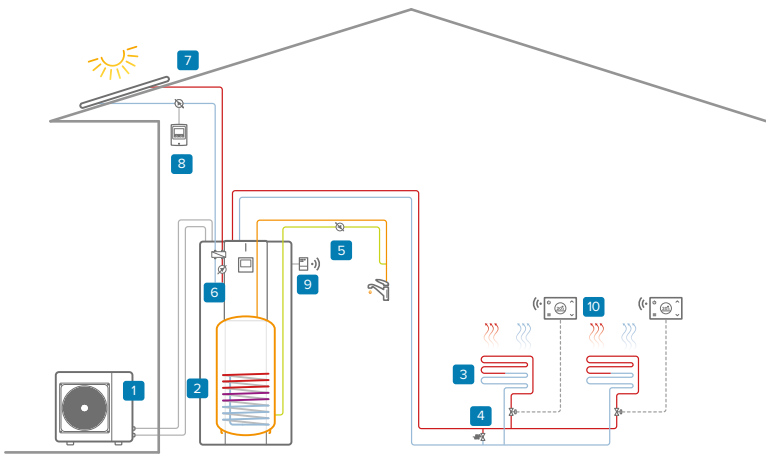

Full electric single-area system with thermal solar:
Heating / Cooling / DHW

- 1 Outdoor unit
- 2 Indoor unit
- 3 heating/cooling zone
- 4 Bypass*
- 5 DHW recirculation pump*
- 6 solar connection kit (optional)
- 7 ELFOSun3 thermal solar (optional)
- 8 solar circulation kit (optional)
- 9 SwitchConnect Wi-Fi receiver (optional)
- 10 Wi-Fi chronothermostat HID-TConnect2 (optional)

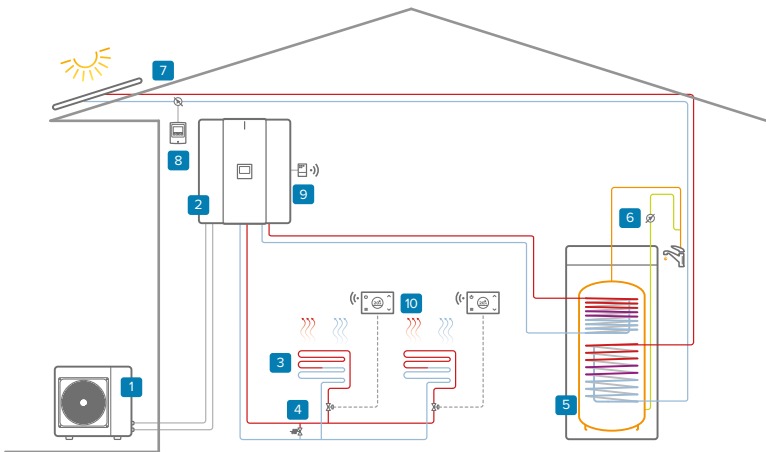

Full electric single-area system with thermal solar:
Heating / Cooling / DHW

- 1 Outdoor unit
- 2 Indoor unit
- 3 heating/cooling zone
- 4 Bypass*
- 5 DHW boiler with solar coil (optional)
DHW recirculation pump*
- 6 ELFOSUN³ thermal solar (optional)
- 7 solar circulation kit (optional)
- 8 SwitchConnect Wi-Fi receiver (optional)
- 9 Wi-Fi chronothermostat HID-TConnect2
- 10 (optional)

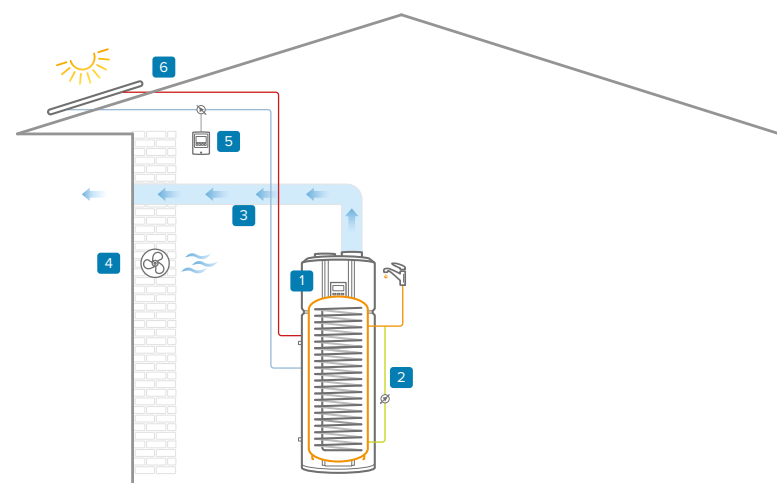

System for DHW production with thermal solar:

- 1 heat pump for DHW with solar system
- 2 provision
- 3 DHW recirculation pump*
- 4 exhaust air duct (optional)*
- 5 ventilation system
- 6 solar circulation kit (optional)
- 7 ELFOSun3 thermal solar (optional)

DWH BOILERS

Domestic hot water tanks for heat pumps



HEAT PUMPS

Energy saving



Integration Heating/DHW

Comfort



DHW

Reliability



Backup heater

- ✓ Additional coil for connection to ELFOSUN3 thermal solar (optional)
- ✓ Inspection flange
- ✓ Magnesium anodic protection
- ✓ Carbon steel tank with vitrification treatment
- ✓ 70 or 100 mm rigid polyurethane insulation

Dimensions and connections

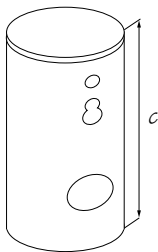

			ACS200X	ACS300X	ACS500X
Dimensions	ØxA	mm	640x1.215	640x1.615	790x1.705
Weight		kg	77	98	128
External diameters	DHW supply	inch		1" 1/4	
	DHW inlet	inch		1"	
	Return bottom pipe coil / drain	inch		1/2"	
	Coil supply	inch		1"	
	Coil return / discharge	inch		1"	
	Return bottom pipe coil / drain	inch		1/2"	

Technical data

			ACS200X	ACS300X	ACS500X
Performance	Net water volume	l	196	273	475
	Energy efficiency class	-		B	
	Maximum water temperature	°C		95	
	Insulation: Material / Medium thickness ¹	mm		PU / 70	
	Thermal dispersions	W/K	1,13	1,40	1,78
	Electric heater	kW / p		2 / 1-phase	
Maximum operating pressure	bar		10		
Quantity of exchangers	-		1		
Technical features - standard version					
Upper coil	Surface	m ²	1,50	1,80	2,20
	Internal volume	l	8,60	10,4	12,7
	Heat exchange ²	Coil water 60/50°C Tank water 10/45°C	kW	36	44
Technical features - solar version					
Additional accessory		-	SCS08X	SCS08X	SCS12X
Bottom pipe coil	Surface	m ²	0,80	0,80	1,20
	Internal volume	l	0,65	0,65	0,95
	Heat exchange ²	Coil water 60/50°C Tank water 10/45°C	kW	24	24

Data according to DIN 4708 / EN 12897 / EN 15332
 (1) PU = Polyurethane

(2) Water pipe coil 60/50°C / Water tank 10/45°C

Fan-coils



3.1 Fan-coils



MOOD



ELFOROOM²



ELFOSPACEBOX 3



AURA



LARICE MP

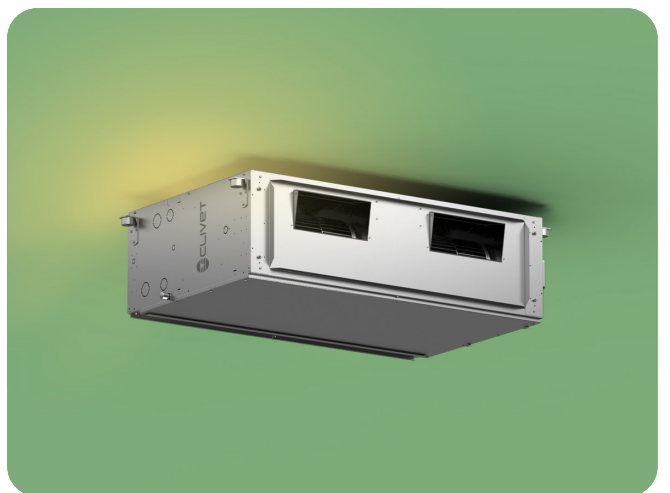

LARICE HP

FAN COILS

MOOD

Wall-mounted fan coil with inverter motor for heating and cooling



Comfort

- Hot Cold
- Dehumidification
- Follow Me (KJR-90D optional)
- Anti cold air
- Temperature compensation

Health

- High density filter

Convenience

- Autorestart

Management and connectivity

- Input ON/OFF
- Remote control
- Wired controller (optional)
- Centralised controller (optional)
- Port Modbus
- CONTROL4 management
- Input 0-10V
- Input ON/OFF

- ✓ Standard supplied with 3-way ON/OFF valves and potential-free contact for generator demand
- ✓ Quiet and efficient, thanks to the fan's brushless DC motor
- ✓ Standard supplied infrared remote control
- ✓ Standard supplied input contact for 0-10V management
- ✓ Management via Modbus port with connection to BMS or CONTROL4 NRG

Dimensions and connections

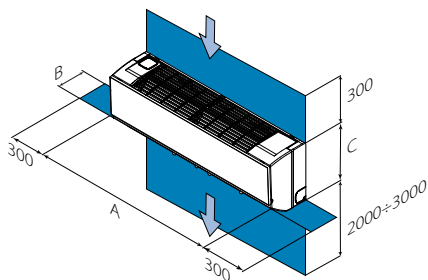

For trouble-free operation of the unit it is essential to maintain the safety distances indicated.

Size			1	2	3	4	5
Dimensions	AxCxB	mm		916x290x233			1.074x317x237
Weight		kg		12,7			14,9
External diameters	Water	inch			3/4"		
	Condensate drain	mm			20		

FAN COILS

Management with energy assistant

Mood can be connected to CONTROL4 NRG, the touch-screen centraliser that coordinates the entire system intelligently and efficiently to always ensure the utmost comfort at the lowest possible cost. By connecting the fan coils to this central "brain", the heat diffusion system can be managed with "room by room" temperature control by turning the individual thermostats with temperature and humidity control (where available) or directly on the terminal units, changing their speed and reducing consumption. The temperature in the house will certainly be more consistent and controlled, for maximum comfort. It is also possible to create and manage dual emitter systems: fan coils for cooling and radiant panels for heating.



Accessories

	KJR90X	KJR90 electronic room control for wall installation		CCM09 to exhaustion	Wired centraliser with weekly scheduler
	PROL5X	5-metre extension lead for connecting the KJR-90D electronic wall-mounted room controller		CCM-180A/WS	Wired centraliser with 6.2" touchscreen display and weekly scheduler
	KJR150X	Indoor units' group controller		CCM-270A/WS	Wired centraliser with 10.1" touchscreen display and weekly scheduler
	CCM30BX	Touch-key indoor units' centralized controller			

FAN COILS

Technical data

Size				1	2	3	4	5
Cooling	Total yield		kW	2,51	2,62	3,81	3,96	4,87
	Sensible yield	Water 7/12°C	kW	2,00	2,07	3,18	2,66	4,11
	Water flow-rate	Ambient air 27°C/19°Cwb	l/h	432	451	656	682	839
	Water pressur drop	Maximum ventilation speed	kPa	31,6	37,2	56,8	41,2	50,7
Heating	Yield	Water 45/40°C	kW	2,94	3,23	4,30	4,84	5,26
	Water flow-rate	Ambient air 20°C	l/h	365	556	741	682	906
	Water pressur drop	Maximum ventilation speed	kPa	37,5	40,6	61,9	43,7	51,7
	Yield	Water 50°C/cool water flow-rate	kW	3,4	3,68	4,59	5,43	5,98
	Water flow-rate	Ambient air 20°C	l/h	465	501	656	770	839
	Water pressur drop	Maximum ventilation speed	kPa	13,8	15,7	24,8	45,7	54,6
Power input	Minimum / Maximum	W	10/13	9/15	15/34	13/26	18/38	
Operating pressure	Water content	bar			16			
Airflow ¹	Minimum / Nominal / Maximum	m ³ /h	400/454/492	413/485/585	590/689/825	552/741/862	717/849/979	
Sound power	Minimum / Maximum	dB(A)	39/44	35/44	47/57	42/50	47/56	
Sound pressure @1m	Minimum / Maximum	dB(A)	27/32	23/32	35/45	30/38	35/44	
Power supply	Voltage/Frequency/Phases	V/Hz/n°			230/50/1			

Sound levels tested in an anechoic chamber according to ISO 3744
 (1) With clean filters

ELFOROOM²

Slim floor- or ceiling-mounted fan coil with inverter motor for heating and cooling



Comfort

- Hot
Cold
- Dehumidification
- Follow Me
(KJR-90D
optional)
- Anti cold air
- Temperature
compensation

Health

- High density
filter
- Air purification
(optional)

Management and connectivity

- Input ON/
OFF
- Wired controller
- Centralised
control
(optional)
- Port
Modbus
- CONTROL4
management
- Input
0-10 V
- Input
ON/OFF

- ✓ Suitable for any installation: vertical or horizontal, cased or uncased
- ✓ Quiet and efficient, thanks to the fan's brushless DC motor
- ✓ Management via ON/OFF, 3-speed or 0-10V contacts and ON/OFF output for calling an external device
- ✓ Optional germicidal UV lamp for air purification
- ✓ Management via Modbus port with connection to BMS or CONTROL4 NRG

Dimensions and connections

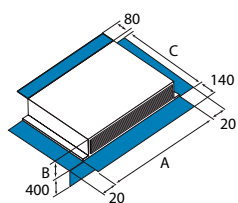

ELFOROOM² OUTVOT
Cased unit

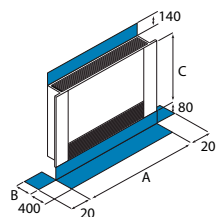

ELFOROOM² OUTVL-OUTVOT
Cased unit

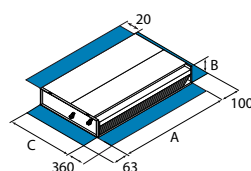

ELFOROOM² INVOT
Uncased unit

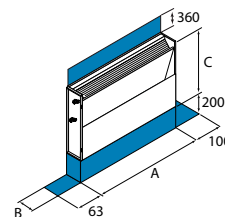

ELFOROOM² INVOT
Uncased unit

For trouble-free operation of the unit it is essential to maintain the safety distances indicated.

FAN COILS

Ready for anything

ELFOROOM2 is highly flexible, thanks to the availability of many accessories that enhance its potential.

The unit can be managed with the on-board control, with LCD display and very discreet, with external thermostat, ON/OFF input via potential-free contact or input with 0-10V signal.

Multiple ELFOROOM2 units can also be grouped into mini-networks of up to 9 units with master/slave management via thermostat or via a CONTROL4 NRG centralized control unit or BMS using the Modbus protocol.

The rest of the optional equipment is designed to facilitate installation: feet for fixing to the ground, recessed fan coil / grid kit to make uncased installations invisible, telescopic or 90° plenum for ducting.

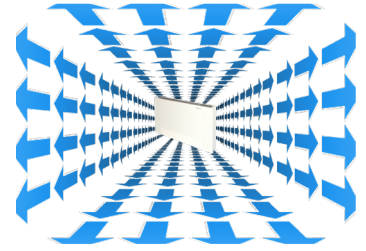

Configurations

type of system:

CC2 2-pipe (Standard)
 CC4 4 pipe

HYDRAULIC CONNECTIONS

SX Connections on the left (Standard)
 DX Right side fittings

TYPE OF INSTALLATION:

OUTVL With casing for vertical installation
 OUTVOT With casing for vertical or horizontal installation
 OUTRAD With casing for vertical installation, with ventilated radiant plate
 INVOT Uncased for vertical or horizontal installation

CONTROL ELECTRONIC











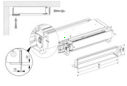

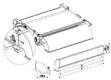

IN-MOD Onboard thermostat and RS485 port as standard
 CSEMP 4-speed simplified on-board thermostat
 MOD RS485 port as standard and provision for connection to Modbus thermostat
 SC3V Ready for connection to 3-speed thermostat
 SC010 Ready for connection to 0-10V thermostat

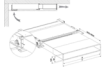
AIR PURIFICATION

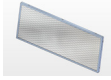
- Standard filter (standard)
 UVPCO UV germicidal lamp kit with support

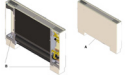
Size (CC2 Version)			003.0	005.0	011.0	015.0	017.0	
Dimensions	with casing	AxCxB	mm	737x579x130	937x579x130	1137x579x130	1337x579x130	1537x579x130
	uncased	AxCxB	mm	527x586x130	727x586x130	927x586x130	1127x586x130	1327x586x130
Weight	with casing		kg	17	20	23	26	29
	uncased		kg	9	12	15	18	21
External diameters	Water		inch			3/4"		
	Condensate drain		mm			14		

Accessories

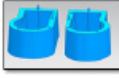
	KASPX	Return plenum kit		FXPPX	Floor fixing brackets kit
	GRA1X	Air outflow grille		KV3VBX	3-way valve kit with electrothermal head and balancing
	PR90MX	90° air outlet plenum		KV3B4X	3-way valve kit with electrothermal head and balancing for 4-pipe system (Available only with B4T)
	PMSTX	Telescopic upper supply plenum kit		KCMDX	Motor connection cables for unit with couplings on the right
	GMX	Outlet grille		HIDE2X	Electro-mechanical thermostat for wall installation with built-in temperature probe
	BACKVX	Rear painted panel for cased units		HIDE3X	Electro-mechanical thermostat for wall installation with built-in temperature probe
	PCIX	Uncased closure panel		HIDT6X	Electronic thermostat for wall installation with built-in temperature probe
	CSFIX	Formwork for uncased installation			
	KPDX	Plinth kit			

Technical data

Size				003.0	005.0	011.0	015.0	017.0
Cooling	Total yield	Water 7/12°C	kW	0,91	2,12	2,81	3,30	3,71
	Sensible yield	Ambient air 27°C/19°Cwb	kW	0,71	1,54	2,11	2,56	2,90
	Water flow-rate	Maximum ventilation speed	l/h	157	365	483	568	638
	Water pressur drop		kPa	12,1	8,2	17,1	18,0	21,2
Heating	Yield	Water 45/40°C	kW	1,02	2,21	3,02	3,80	4,32
	Water flow-rate	Ambient air 20°C	l/h	175	380	518	654	743
	Water pressur drop	Maximum ventilation speed	kPa	9,1	9,2	19,1	21,2	23,3
	Yield	Water 50°C/cool water flow-rate	kW	1,17	2,55	3,52	4,43	5,09
	Water flow-rate	Ambient air 20°C	l/h	157	365	483	568	638
	Water pressur drop	Maximum ventilation speed	kPa	5,8	6,6	14,6	14,4	22,9
Power input	Minimum / Maximum		W	5/11	4/19	6/20	5/29	5/33
Operating pressure	Water content		bar			10		
Airflow ¹	Minimum / Nominal / Maximum		m ³ /h	49/91/146	124/210/294	194/318/438	302/410/567	364/479/663
Sound power	Minimum / Maximum		dB(A)	37/54	37/54	37/54	37/55	37/57
Sound pressure @1m	Minimum / Maximum		dB(A)	24/41	25/42	26/44	26/46	28/47
Power supply	Voltage/Frequency/Phases		V/Hz/n°			230/50/1		

Sound levels tested in an anechoic chamber according to ISO 3744
 (1) With clean filters

FAN COILS

AURA - 3-speed version

Floor- or ceiling-mounted fan coil with 3-speed motor for heating and cooling



Comfort



Hot Cold



Dehumidification



Follow Me



Anti cold air (on thermostat)

Health



High density filter

Convenience



Auto restart (on thermostat)

Management and connectivity



Input ON/OFF



Wired controller



Centralised controller (optional)



Port Modbus



CONTROL4 management

- ✓ Sleek and elegant design, suitable for blending into any environment
- ✓ Suitable for any installation: vertical or horizontal, cased or uncased
- ✓ Complete range: sizes from 1.5 kW to 8.3 kW, ideal for houses or hotel rooms
- ✓ Can be adapted on-site to have fittings on the right side as well
- ✓ Management via Modbus port (in the controller) with connection to BMS or Control4 NRG

Dimensions and connections

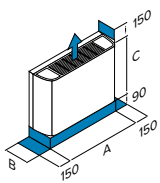

CAS
Cased unit

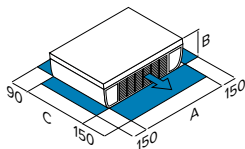

UNC
Uncased unit

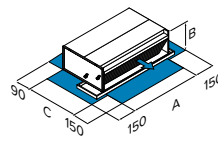
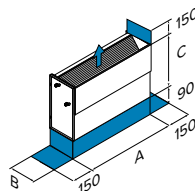

For trouble-free operation of the unit it is essential to maintain the safety distances indicated.

Size (CC2 Version)			1	2	3	4	6	8	10	12
Dimensions	with casing	AxCxB mm	790x495x200		1.020x495x200		1.240x495x200		1.360x495x200	1.360x591x200
	uncased	AxCxB mm	628x455x200		858x455x200		1.078x455x200		1.198x455x200	1.198x551x200
Weight	with casing	kg	16,3	16,7	20,0	20,8	25,4	26,3	28,5	34,0
	uncased	kg	11,6	12,0	13,9	14,8	18,2	18,8	21,7	25,2
External diameters	Water	inch	3/4"							
	Condensate drain	mm	18,5							

Dedicated control

The unit can be selected with the innovative, specially designed KJRP-86R user interface. The controller can either be installed on board the unit (for cased versions) or remotely on the wall. It has a touch screen, back-light, 3-speed control + AUTO, ON/OFF timer and water probe for anti-cold air function. The control is equipped with a Modbus port for connection to CONTROL4 NRG or to BMS managers running on this protocol.



Configurations

TIPO IMPIANTO:

CC2	2-pipe (Standard)
CC4	4 pipe

AIR RETURN

R3	From the bottom (vertical installation) / from the back (horizontal installation) (standard)
RF	From the front (vertical installation) / from the bottom (horizontal installation)

HYDRAULIC CONNECTIONS

SX	Connections on the left (standard)
----	------------------------------------

DX Right side fittings

VALVES MOUNTED ON BOARD:

-	not required (standard)
3V2	3-way ON/OFF valves for 2-pipe version
3V2	3-way ON/OFF valves for 4-pipe version

BUILT-IN THERMOSTAT:

NOHMI	not required (standard)
HMIAM	KJRP-86R control mounted on board

Accessories

	BRVHX	Auxiliary condensate collection tray for vertical/horizontal installation		HMIFACX	KJRP-86R wired controller for on-board or wall installation
	KPDX	Feet kit		BOXX	Wall installation with concealed box KJRP-86R
	3V2DX	3-way ON/OFF valves kit for 2-pipe system (3V2DX for right side fittings / 3V2SX for left side fittings)		DCPRX	Power interface to control 4 fan coils and valves for 2-4 systems
	3V4DX	3-way ON/OFF valves kit for 4-pipe system (3V4DX for right side fittings / 3V4SX for left side fittings)		HID-TIFX	Thermostat for fancoil unit with 0-10V port and water probe included (AC/EC fan control)
	COADX	1Pair of adapters 3/4 F Eurokonus > 1/2 female (for 2-pipe units)			

Technical data

Size		R3 Version	1*	2	3*	4	6	
Cooling	Total yield		kW	1,65	2,25	2,65	3,05	4,20
	Sensible yield	Water 7/12°C	kW	1,25	1,65	2,05	2,23	3,05
	Water flow-rate	Ambient air 27°C/19°Cwb	l/h	283	386	454	523	720
	Water pressur drop	Maximum ventilation speed	kPa	15,8	33,2	18	26,7	41,2
Heating	Yield		kW	1,85	2,35	3,05	3,15	4,30
	Water flow-rate	Water 45/40°C	l/h	317	403	523	540	740
	Water pressur drop	Ambient air 20°C						
		Maximum ventilation speed	kPa	15,1	33,2	17,6	23,3	37,2
	Yield	Water 50°C/cool water flow-rate	kW	1,93	2,02	2,89	3,28	4,55
	Water flow-rate	Ambient air 20°C	l/h	283	386	454	523	720
	Water pressur drop	Maximum ventilation speed	kPa	11	19,5	11,8	20,1	21,1
Power input		Minimum / Maximum	W	14/35	15/40	14/47	14/47	19/51
Operating pressure		Water content	bar			16		
Airflow ¹		Minimum / Nominal / Maximum	m ³ /h	142/165/255	139/192/255	180/273/400	184/284/425	319/450/595
Sound power		Minimum / Maximum	dB(A)	34/47	39/53	31/46	32/47	37/52
Sound pressure @1m		Minimum / Maximum	dB(A)	21/35	27/42	18/34	19/34	31/40
Power supply		Voltage/Frequency/Phases	V/Hz/n°			230/50/1		

Sound levels tested in an anechoic chamber according to ISO 3744

(1) With clean filters

*RF version not available

Size		R3 Version	8*	10*	12*	
Cooling	Total yield		kW	5,35	6,75	8,25
	Sensible yield	Water 7/12°C	kW	3,96	5,09	6,08
	Water flow-rate	Ambient air 27°C/19°Cwb	l/h	917	1157	1414
	Water pressur drop	Maximum ventilation speed	kPa	61,5	40,3	64,7
Heating	Yield	Water 45/40°C	kW	5,70	7,15	8,50
	Water flow-rate	Ambient air 20°C	l/h	977	1.226	1.457
	Water pressur drop	Maximum ventilation speed	kPa	60,9	42,2	62,0
	Yield	Water 50°C/cool water flow-rate	kW	5,99	7,91	9,35
	Water flow-rate	Ambient air 20°C	l/h	917	1157	1.414
	Water pressur drop	Maximum ventilation speed	kPa	32,9	18,9	39,3
Power input		Minimum / Maximum	W	35/91	64/110	82/118
Operating pressure		Water content	bar			
Airflow ¹		Minimum / Nominal / Maximum	m ³ /h	404/574/800	591/885/1.150	836/1.132/1.300
Sound power		Minimum / Maximum	dB(A)	43/59	46/62	50/63
Sound pressure @1m		Minimum / Maximum	dB(A)	31/47	33/50	37/50
Power supply		Voltage/Frequency/Phases	V/Hz/n°			

Sound levels tested in an anechoic chamber according to ISO 3744

(1) With clean filters

*RF version not available

AURA - Inverter version

Floor- or ceiling-mounted fan coil with inverter motor for heating and cooling

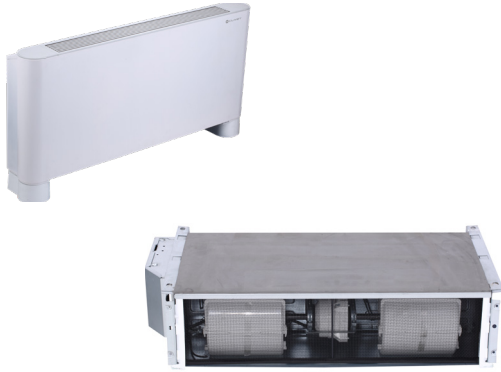

Comfort



Hot
Cold



Dehumidification



Follow Me



Anti cold air
(on thermostat)

Health



High density
filter

Convenience



Auto restart
(on thermostat)

Management and connectivity



Input ON/
OFF



Wired controller



Wired controller
(optional)



Port
Modbus



CONTROL4
management

- ✓ Sleek and elegant design, suitable for blending into any environment
- ✓ Suitable for any installation: vertical or horizontal, cased or uncased
- ✓ Quiet and efficient, thanks to the fan's brushless DC motor
- ✓ Complete range: sizes from 1.5 kW to 8.3 kW, ideal for houses or hotel rooms
- ✓ Can be adapted on-site to have fittings on the right side as well
- ✓ Management via Modbus port with connection to BMS or CONTROL4 NRG

Dimensions and connections

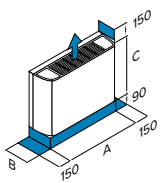

CAS
Cased unit

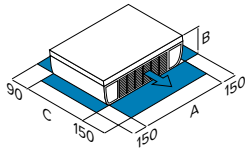

UNC
Uncased unit

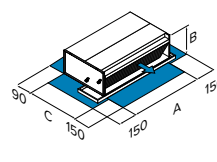
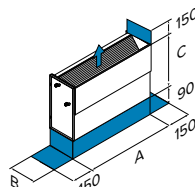

For trouble-free operation of the unit it is essential to maintain the safety distances indicated.

Size (CC2 Version)			1	2	3	4	6	8	10	12
Dimensions	with casing	AxCxB mm	790x495x200	1020x495x200	1240x495x200	1360x495x200	1360x591x200			
	uncased	AxCxB mm	628x455x200	858x455x200	1078x455x200	1198x455x200	1198x551x200			
Weight	with casing	kg	16,3	16,7	20,0	20,8	25,4	26,3	28,5	34,0
	uncased	kg	11,6	12,0	13,9	14,8	18,2	18,8	21,7	25,2
External diameters	Water	inch	3/4"							
	Condensate drain	mm	18,5							

Dedicated control

The unit can be selected with the innovative, specially designed KJRP-86R user interface. The controller can either be installed on board the unit (for cased versions) or remotely on the wall. It has a touch screen, back-light, 3-speed control + AUTO, ON/OFF timer and water probe for anti-cold air function.

The control is equipped with a Modbus port for connection to CONTROL4 NRG or to BMS managers running on this protocol.



Configurations

TYPE OF SYSTEM:

CC2	2-pipe (Standard)
CC4	4 pipe

AIR RETURN

R3	From the bottom (vertical installation) / from the back (horizontal installation) (standard)
RF	From the front (vertical installation) / from the bottom (horizontal installation)

HYDRAULIC CONNECTIONS

SX	Connections on the left (standard)
DX	Right side fittings











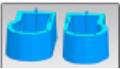

VALVES MOUNTED ON BOARD:

-	not required (standard)
3V2	3-way ON/OFF valves for 2-pipe version
3V2	3-way ON/OFF valves for 4-pipe version

BUILT-IN THERMOSTAT:

NOHMI	not required (standard)
HMIAM	KJRP-86R control mounted on board

Accessories

	BRVHX	Auxiliary condensate collection tray for vertical/horizontal installation		PROL5X	5-metre extension lead for connecting the KJR-90D electronic wall-mounted room controller
	KPDX	Feet kit		KJR150X	Indoor units' group controller
	3V2DX	3-way ON/OFF valves kit for 2-pipe system (3V2DX for right side fittings / 3V2SX for left side fittings)		CCM30BX	Touch-key indoor units' centralized controller
	3V2SX			CCM09 to exhaustion	Wired centraliser with weekly scheduler
	3V4DX	3-way ON/OFF valves kit for 4-pipe system (3V4DX for right side fittings / 3V4SX for left side fittings)		CCM-180A/ WS	Wired centraliser with 6.2" touchscreen display and weekly scheduler
	3V4SX			CCM-270A/ WS	Wired centraliser with 10.1" touchscreen display and weekly scheduler
	COADX	Pair of adapters 3/4 F Eurokonus > 1/2 female (for 2-pipe units)			
	HMIFDCX	KJRP-75A electronic wired controller for unit- or wall-mounting			
	EXTENX	KJRP-75A wired controller connection extension cable (2 m)			
	KCMDX	Fan connection cables for units with connections on the right (per AURA DC 9 to 12)			
	KJR90X	KJR90 electronic room control for wall installation			

Technical data

Size		R3 Version	1*	2	3*	4	6	
Cooling	Total yield		kW	1,50	1,95	2,35	2,85	3,90
	Sensible yield	Water 7/12°C	kW	1,14	1,42	1,79	2,06	2,90
	Water flow-rate	Ambient air 27°C/19°Cwb	l/h	260	330	400	490	670
	Water pressur drop	Maximum ventilation speed	kPa	13,9	27,2	13,3	26	37,4
Heating	Yield		kW	1,57	2,05	2,60	2,95	4,00
	Water flow-rate	Water 45/40°C	l/h	270	350	450	510	700
	Water pressur drop	Ambient air 20°C Maximum ventilation speed	kPa	15,1	25,3	14,3	24,4	36,5
	Yield		kW	1,81	1,93	2,92	3,14	4,37
	Water flow-rate	Water 50°C/cool water flow-rate	l/h	260	330	400	490	670
	Water pressur drop	Ambient air 20°C Maximum ventilation speed	kPa	9,6	17,0	10,3	18,2	19,0
Power input	Minimum / Maximum	W	8/15	9/19	7/16	8/18	10/28	
Operating pressure	Water content	bar	16					
Airflow ¹	Minimum / Nominal / Maximum	m ³ /h	150/170/255	150/210/255	190/315/400	190/300/425	310/450/595	
Sound power	Minimum / Maximum	dB(A)	34/47	38/52	29/43	29/46	36/52	
Sound pressure @1m	Minimum / Maximum	dB(A)	21/34	25/39	18/29	19/32	30/40	
Power supply	Voltage/Frequency/Phases	V/Hz/n°	230/50/1					

Sound levels tested in an anechoic chamber according to ISO 3744

(1) With clean filters

*RF version not available

Size		R3 Version	8*	10*	12*	
Cooling	Total yield		kW	4,85	6,35	8,25
	Sensible yield	Water 7/12°C	kW	3,63	4,98	6,12
	Water flow-rate	Ambient air 27°C/19°Cwb	l/h	830	1.090	1.430
	Water pressur drop	Maximum ventilation speed	kPa	54,3	32,8	71,4
Heating	Yield		kW	5,25	7,05	8,70
	Water flow-rate	Water 45/40°C	l/h	910	1.220	1.510
	Water pressur drop	Ambient air 20°C Maximum ventilation speed	kPa	53,4	37,6	62,6
	Yield		kW	5,68	8,15	9,37
	Water flow-rate	Water 50°C/cool water flow-rate	l/h	830	1.090	1.430
	Water pressur drop	Ambient air 20°C Maximum ventilation speed	kPa	28,5	17,6	39,9
Power input	Minimum / Maximum	W	13/47	18/87	22/106	
Operating pressure	Water content	bar	16			
Airflow ¹	Minimum / Nominal / Maximum	m ³ /h	420/600/800	530/875/1190	680/980/1.300	
Sound power	Minimum / Maximum	dB(A)	43/59	46/62	47/63	
Sound pressure @1m	Minimum / Maximum	dB(A)	30/45	31/50	33/50	
Power supply	Voltage/Frequency/Phases	V/Hz/n°	230/50/1			

Sound levels tested in an anechoic chamber according to ISO 3744

(1) With clean filters

*RF version not available

ELFOSPACE BOX3

Boxed 4-way fan coil with inverter motor for heating and cooling



Comfort



Hot Cold



Dehumidification



Follow Me



Anti cold air (on thermostat)



Temperature compensation

Reliability



Condensate drain pump

Health



High density filter

Convenience



Auto Restart

Management and connectivity



Input ON/OFF



Remote control



Wired controller (optional)



Centralised control (optional)



Port Modbus



CONTROL4 management



input 0-10V (021.0+041.0)

- ✓ Management with potential-free contact input or 0-10V input, alarm output
- ✓ Quiet and efficient, thanks to the fan's brushless DC motor
- ✓ Standard supplied infrared remote control
- ✓ Standard supplied condensate drain pump on board
- ✓ Management via Modbus port with connection to BMS or CONTROL4 NRG

Dimensions and connections

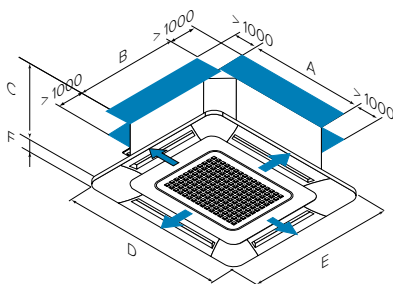

Size (CC2 Version)			007.0	011.0	015.0	021.0	031.0	041.0
Dimensions	unit	AxCxB mm	575x261x575			840x230x840		
	panel	AxCxB mm	647x50x647			950x45x950		
Weight	unit	kg	16,5+2,5	16,5+2,5	16,5+2,5	23+6	27+6	27+6
	panel	kg						
External diameters	Water	inch	3/4"					
	Condensate drain	mm	25			32		

For trouble-free operation of the unit it is essential to maintain the safety distances indicated.

Efficient and quiet

ELFOSPACE BOX3 is standard supplied with a brushless DC motor fan, featuring advanced high efficiency technology that ensures low noise levels and consistent and precise control of the room temperature. Thanks to this, they are suitable for many applications in commercial and industrial sectors but also for particular situations such as hospitals or airports.











The power consumption of fan coils with brushless DC ventilation motor is reduced by up to 60% compared to corresponding models with asynchronous motor, while the noise level is 2+5 dB(A) lower, making the environment more comfortable with lower costs.

Configurations

TYPE OF SYSTEM:

- CC2 2-pipe (Standard)
- CC4 4 pipe

Accessories

	KJR90X	KJR90 electronic room control for wall installation		CCM-270A/WS	Wired centraliser with 10.1" touchscreen display and weekly scheduler (compatible with 021.0 to 041.0)
	PROL5X	5-metre extension lead for connecting the KJR-90D electronic wall-mounted room controller		360PX	Air return and supply frame with supply at 360°
	KJR150X	Indoor units' group controller		3V2X	Three-way valve kit for 2-pipe "on/off" system
	CCM30BX	Touch-key indoor units' centralised controller		3V4X	Three-way valve kit for 4-pipe "on/off" system
	CCM09 ad esaurimento	Wired centraliser with weekly scheduler		DTX	Auxiliary condensate collection tray
	CCM-180A/WS	Wired centraliser with 6.2" touchscreen display and weekly scheduler (compatible with 021.0 to 041.0)			

FAN COILS

Technical data

Size				007.0	011.0	015.0	021.0	031.0	041.0
Cooling	Total yield		kW	2,98	3,96	4,20	5,93	7,87	11,2
	Sensible yield	Water 7/12°C	kW	2,49	3,20	3,45	5,00	6,68	9,04
	Water flow-rate	Ambient air 27°C/19°Cwb Maximum ventilation speed	l/h	513	681	722	1.020	1.354	1.925
	Water pressur drop		kPa	10,0	11,5	12,3	23,8	22,3	36,6
Heating	Yield	Water 45/40°C	kW	2,61	4,08	4,95	6,06	9,16	10,07
	Water flow-rate	Ambient air 20°C	l/h	449	702	851	1.042	1.576	1.732
	Water pressur drop	Maximum ventilation speed	kPa	12,1	12,7	9,4	25,9	28,8	49,2
	Yield	Water 50°C/cool water flow-rate	kW	3,11	4,58	5,58	7,01	10,4	11,5
	Water flow-rate	Ambient air 20°C	l/h	513	681	722	1.020	1.354	1.925
	Water pressur drop	Maximum ventilation speed	kPa	16,3	10,7	9,0	12,8	10,7	8,9
Power input	Minimum / Maximum	W	5/15	9/37	21/43	20/41	45/85	39/126	
Operating pressure	Water content	bar				16			
Airflow ¹	Minimum / Nominal / Maximum	m ³ /h	322/429/535	381/477/610	494/611/781	768/987/1175	1.236/1.371/1.581	1.198/1.415/1.871	
Sound power	Minimum / Maximum	dB(A)	39/51	42/54	44/59	45/55	53/60	51/64	
Sound pressure @1m	Minimum / Maximum	dB(A)	27/39	30/42	32/43	33/43	41/48	39/49	
Power supply	Voltage/Frequency/Phases	V/Hz/n°				230/50/1			

Sound levels tested in an anechoic chamber according to ISO 3744
(1) With clean filters

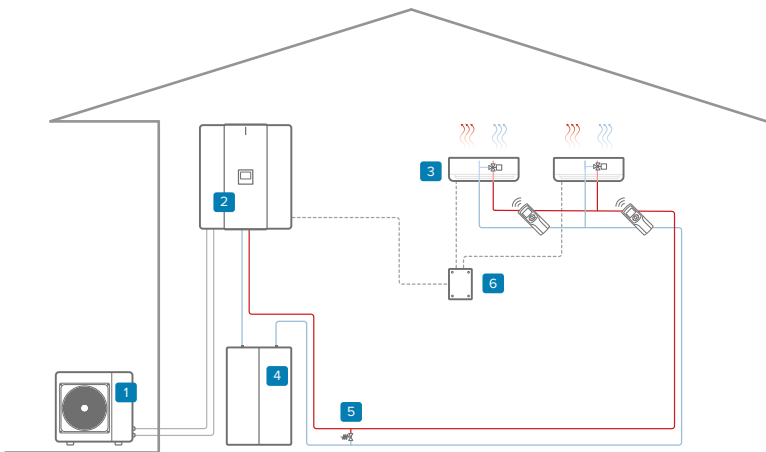

Single-zone system: heating/cooling

- 1 Outdoor unit
- 2 Indoor unit
- 3 Heating/cooling zone
- 4 System inertial storage (optional)
- 5 Bypass*
- 6 Box for signal to generator*

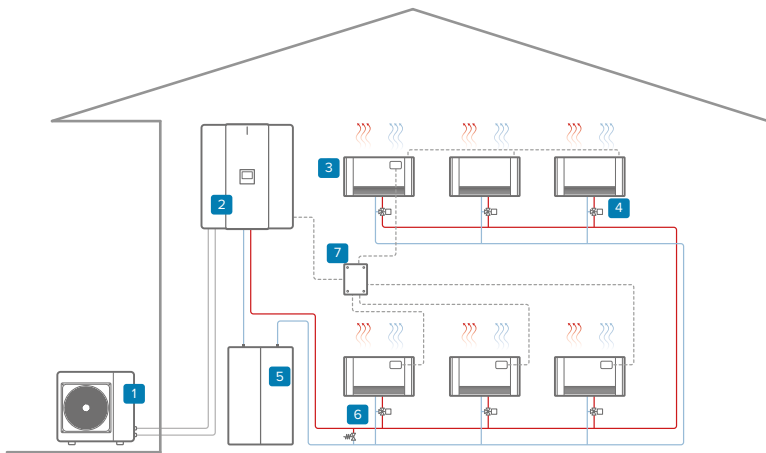

Single-zone system: heating/cooling

- 1 Outdoor unit
- 2 Indoor unit
- 3 Heating/cooling zone
- 4 3-way valve kit (optional)
- 5 System inertial storage (optional)
- 6 Bypass*
- 7 Box for signal to generator*

Note: if valves kits are not present in the terminal unit, the heat pump needs to be always operating

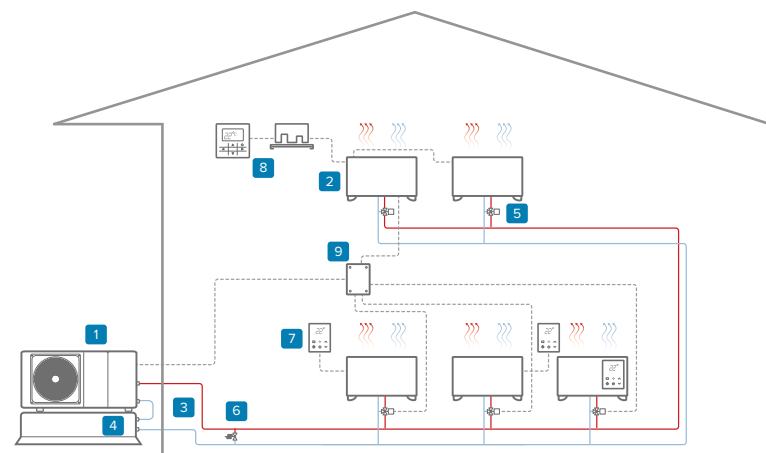

Single-zone system: heating/cooling

- 1 Outdoor unit
- 2 Heating/cooling zone
- 3 System inertial storage connection kit (optional)
- 4 System inertial storage (optional)
- 5 3-way valve kit (optional)
- 6 Bypass*
- 7 Wired control (optional)
- 8 Signal diffuser (optional)
- 9 Box for signal to generator*

Note: if valves kits are not present in the terminal unit, the heat pump needs to be always operating

FAN COILS

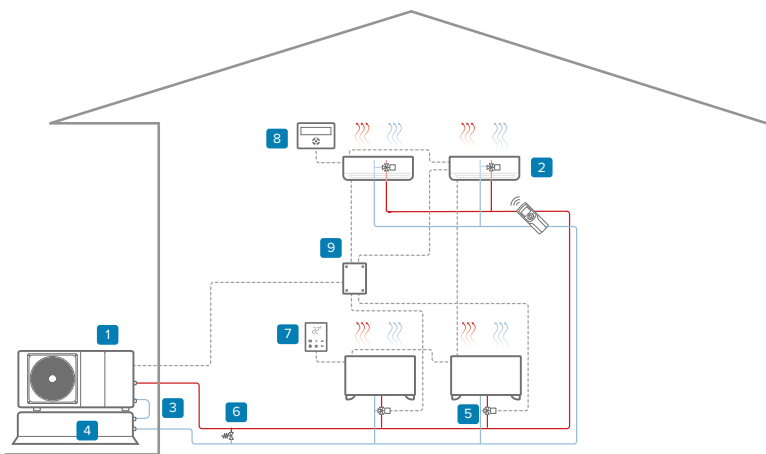

Single-zone system: heating/cooling

- 1 Outdoor unit
- 2 Heating/cooling zone
- 3 System inertial storage connection kit
- 4 (optional)
- 5 System inertial storage (optional)
- 6 3-way valve kit (optional)
- 7 Bypass*
- 8 Wired control (optional)
- 9 Centralizer (optional)
- 10 Box for signal to generator*

Note: if valves kits are not present in the terminal unit, the heat pump needs to be always operating

LARICE MP

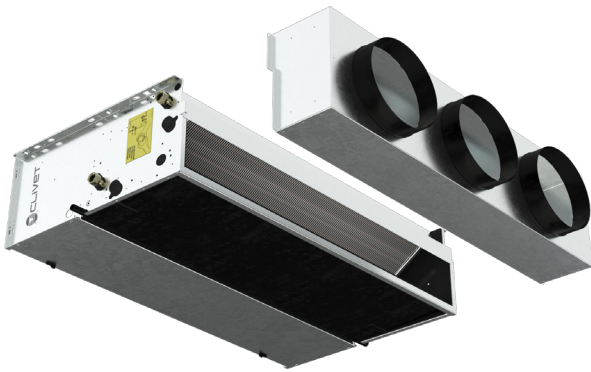

Management and connectivity



Potential-free contact



0-10 V input



Modbus Port
(on thermostat)



CONTROL4 NRG
management
(on thermostat)

Comfort



Hot
Cold



Dehumidification



Anti cold air
(on thermostat)

Convenience



Auto Restart
(on thermostat)

Health



High density
filter

- ✓ Extremely slim, can easily be installed even in space-restricted false ceilings
- ✓ Quiet and efficient, thanks to the fan's brushless DC motor
- ✓ Wide range of accessories and configurations to fulfil all installation requirements
- ✓ Unit for horizontal or vertical installation
- ✓ Management via Modbus port with connection to BMS or CONTROL4 NRG

Configurations

TYPE OF SYSTEM:

CC2 2-pipe (Standard)
 CC4 4 pipe

INSTALLATION:

INH/V Horizontal/vertical uncased (Standard)

AIR RETURN:

RP From the back / From the bottom (Standard)
 RB From the bottom / From the front

HYDRAULIC CONNECTIONS

SX Connections on the left (Standard)
 DX Right side fittings









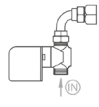
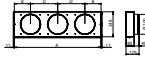
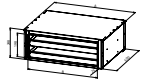
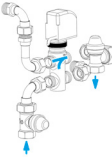
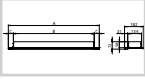
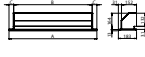
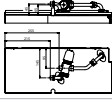
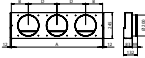
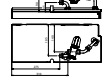
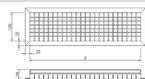

BUILT-IN VALVES

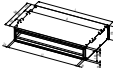
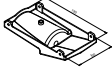
- not required (Standard)
 2V2 2-way ON/OFF valves for 2-pipe version
 3V2 3-way ON/OFF valves for 2-pipe version
 2V4 2-way ON/OFF valves for 4-pipe version
 3V4 3-way ON/OFF valves for 4-pipe version

MOTORE

DUE EC Brushless Motor
 DUA AC Motor

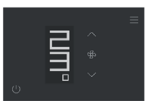
Accessories

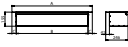
	2V2X	Two-way "on/off" valve kit for main coil for 2-pipes units		PCCRAX	Return air plenum with circular connections
	2V4OHX	Two-way "on/off" valve kit for additional coil for 4-pipes units		SILRX	Silencer return air plenum
	3V2X	Three-way "on/off" valve kit for main coil for 2-pipes units		FMX	Straight supply air flange
	3V4OHX	Three-way "on/off" valve kit for additional coil for 4-pipes units		F90MX	90° supply air flange
	VB2X	Balancing valve kit for main coil for 2-pipes units		PCCMAX	Supply air plenum with circular connections
	VB4X	Balancing valve kit for additional coil for 4-pipes units		BOMX	Supply air nozzle
	BROPX	Auxiliary drain pan (horizontal installation)		SILMX	Silencer supply air plenum
	BRVX	Auxiliary condensate collection pan (horizontal installation)		HIDE2X	Electro-mechanical thermostat for wall-installation with built-in temperature probe (for AC version)
	DPHX	Condensate drain pump for horizontal installation		HMIFACX	KJRP-86R electronic wired controller for unit or wall-mounting
	DPVX	Condensate drain pump for vertical installation		BOXX	Box for wall installation of KJRP-86R user interface
	GFDX	Return air grille for straight flange		HID-TIFX	Thermostat for fancoil unit with 0-10V port and water probe included (AC/EC fan control)
	FDAX	Straight return air flange			
	GF90X	Return air grille for 90° flange			
	F90AX	90° return air flange			

Technical data

Size		DUE-M1	12	22	32	42	52	62	72	82	92	102	112	122
2 pipe														
High speed														
Air flow rate		m ³ /h	290	290	360	360	630	630	980	980	1410	1410	1923	1923
External static pressure		Pa	75	75	68	68	70	70	66	66	72	72	70	70
Cooling capacity	(1)	kW	1,65	1,95	2,23	2,48	3,55	4,25	5,43	5,91	7,67	8,47	10,00	10,60
Sensible capacity	(1)	kW	1,30	1,45	1,63	1,78	2,68	3,04	4,21	4,45	5,86	6,33	7,80	8,20
Water flow-rate	(1)	l/h	284	336	384	427	611	732	935	922	1321	1459	1722	1826
Water pressur drop	(1)	kPa	9,2	15,4	23,0	13,0	19,0	31,0	23,0	15,0	21,0	18,0	39,0	40,0
Heating capacity	(2)	kW	1,90	2,00	2,37	2,52	4,00	4,37	6,27	6,55	8,24	9,35	10,70	11,50
Water flow-rate	(2)	l/h	327	345	408	434	689	753	1080	1128	1419	1611	1843	1981
Water pressur drop	(2)	kPa	8,0	12,3	22,0	13,0	18,0	26,6	23,0	14,0	19,0	18,0	43,0	39,0
Total power input		W	37	37	39	39	64	64	98	98	155	155	246	246
Medium speed														
Air flow rate		m ³ /h	225	225	305	305	540	540	850	850	1175	1175	1638	1638
External static pressure		Pa	50	50	50	50	50	50	50	50	50	50	50	50
Cooling capacity	(1)	kW	1,39	1,55	1,97	2,17	3,21	3,79	4,94	5,34	6,81	7,46	8,60	9,25
Sensible capacity	(1)	kW	1,00	1,15	1,42	1,54	2,38	2,68	3,77	3,97	5,11	5,48	6,50	7,10
Water flow-rate	(1)	l/h	239	267	339	374	553	653	851	841	1173	1285	1481	1593
Water pressur drop	(1)	kPa	6,7	10,8	19,0	10,0	16,0	25,0	19,0	13,0	17,0	14,0	29,0	30,0
Heating capacity	(2)	kW	1,50	1,65	2,05	2,17	3,51	3,80	5,56	5,77	7,09	7,96	9,25	10,00
Water flow-rate	(2)	l/h	258	284	353	374	605	655	958	994	1221	1371	1593	1722
Water pressur drop	(2)	kPa	5,5	8,1	17,0	10,0	15,0	21,0	19,0	12,0	15,0	14,0	34,0	30,0
Total power input		W	21	21	29	29	43	43	67	67	100	100	160	160
Low speed														
Air flow rate		m ³ /h	110	110	240	240	430	430	595	595	900	900	1238	1238
External static pressure		Pa	10	10	32	32	34	34	24	24	30	30	28	28
Cooling capacity	(1)	kW	0,75	0,80	1,64	1,77	2,72	3,14	3,84	4,09	5,66	6,12	6,75	7,20
Sensible capacity	(1)	kW	0,55	0,60	1,17	1,25	1,99	2,20	2,83	2,95	4,15	4,40	5,05	5,50
Water flow-rate	(1)	l/h	129	138	282	305	469	541	661	661	975	1054	1163	1240
Water pressur drop	(1)	kPa	3,5	3,5	13,0	7,0	12,0	18,0	12,0	8,0	12,0	10,0	19,0	20,0
Heating capacity	(2)	kW	0,80	0,80	1,65	1,73	2,88	3,08	4,07	4,19	5,69	6,26	7,00	8,00
Water flow-rate	(2)	l/h	138	138	284	298	496	531	701	722	980	1078	1206	1378
Water pressur drop	(2)	kPa	1,7	2,6	12,0	7,0	10,0	14,0	11,0	6,0	10,0	9,0	25,0	20,0
Total power input		W	7	7	18	18	26	26	30	30	52	52	84	84
Standard power supply		V/n ² /Hz	220-240/1/50											
Type of supply fan	(3)	-	CFGEC											
No. of supply fan		-	1	1	1	1	2	2	2	2	2	2	3	3
H Sound pressure level (supply)	(4)	dB(A)	55	55	55	55	58	58	62	62	64	64	66	66
M Sound pressure level (supply)	(4)	dB(A)	48	48	48	48	49	49	55	55	57	57	59	59
L Sound pressure level (supply)	(4)	dB(A)	43	44	44	44	47	47	52	52	54	54	56	56
H Sound pressure level (return + irradiated)	(4)	dB(A)	41	42	42	42	46	46	53	53	52	52	54	54
M Sound pressure level (return + irradiated)	(4)	dB(A)	29	38	38	38	42	42	44	44	47	47	49	49
L Sound pressure level (return + irradiated)	(4)	dB(A)	27	36	36	36	39	39	42	42	45	45	47	47

(1) Entering exchanger water 7°C (temperature differential 5°C) - Ambient air 27°C D.B. / 19°C W.B.
 (2) Entering exchanger water 45°C (temperature differential 5°C) - Ambient air 20°C

(3) CFG = Centrifugal fan
 (4) Sound levels tested in anechoic chamber and referring to units for 2-pipe systems.

Size		DUE-M1	14	24	34	44	54	64
4 pipe								
High speed								
Air flow rate		m ³ /h	315	625	790	980	1240	1425
External static pressure		Pa	58	58	60	65	60	63
Cooling capacity	(1)	kW	1,65	2,23	3,55	5,35	7,67	10,00
Sensible capacity	(1)	kW	1,30	1,63	2,67	4,13	5,86	7,80
Water flow-rate	(1)	l/h	284	384	611	922	1321	1722
Water pressur drop	(1)	kPa	9,2	23,0	19,0	23,0	21,0	39,0
Heating capacity	(2)	kW	1,29	1,92	3,03	4,22	6,31	7,80
Water flow-rate	(2)	l/h	111	165	261	363	543	672
Water pressur drop	(2)	kPa	3,2	9,0	5,0	9,0	18,0	29,0
Total power input		W	37	39	67	98	155	246
Medium speed								
Air flow rate		m ³ /h	225	305	540	835	1175	1638
External static pressure		Pa	50	50	50	50	50	50
Cooling capacity	(1)	kW	1,39	1,97	3,21	4,88	6,81	8,60
Sensible capacity	(1)	kW	1,00	1,42	2,38	3,71	5,11	6,50
Water flow-rate	(1)	l/h	239	339	553	841	1173	1481
Water pressur drop	(1)	kPa	6,7	19,0	16,0	19,0	17,0	29,0
Heating capacity	(2)	kW	1,07	1,72	2,74	3,87	5,60	7,00
Water flow-rate	(2)	l/h	92	148	236	333	482	603
Water pressur drop	(2)	kPa	2,4	7,0	4,0	7,0	14,0	27,0
Total power input		W	21	29	43	67	100	160
Low speed								
Air flow rate		m ³ /h	110	240	430	595	900	1238
External static pressure		Pa	10	32	34	24	30	28
Cooling capacity	(1)	kW	0,75	1,64	2,72	3,84	5,66	6,75
Sensible capacity	(1)	kW	0,55	1,17	1,98	2,83	4,15	5,05
Water flow-rate	(1)	l/h	129	282	469	661	975	1163
Water pressur drop	(1)	kPa	3,5	13,0	12,0	12,0	12,0	19,0
Heating capacity	(2)	kW	0,56	1,46	2,36	3,09	4,70	6,00
Water flow-rate	(2)	l/h	47	126	203	266	405	517
Water pressur drop	(2)	kPa	1,1	5,0	3,0	5,0	11,0	20,0
Total power input		W	7	18	27	30	52	84
Standard power supply		V/n ³ /Hz	220-240/1/50					
Type of supply fan	(3)	-	CFG EC					
No. of supply fan		-	1	1	2	2	2	3
H Sound pressure level (supply)	(4)	dB(A)	55	55	58	62	64	66
M Sound pressure level (supply)	(4)	dB(A)	48	48	49	55	57	59
L Sound pressure level (supply)	(4)	dB(A)	43	44	47	52	54	56
H Sound pressure level (return + irradiated)	(4)	dB(A)	41	42	46	53	52	54
M Sound pressure level (return + irradiated)	(4)	dB(A)	29	38	42	44	47	49
L Sound pressure level (return + irradiated)	(4)	dB(A)	27	36	39	42	45	47

(1) Entering exchanger water 7°C (temperature differential 5°C) - Ambient air 27°C D.B. / 19°C W.B.
 (2) Entering exchanger water 65°C (temperature differential 10°C) - Ambient air 20°C

(3) CFG = Centrifugal fan
 (4) Sound levels tested in anechoic chamber and referring to units for 2-pipe systems.

Technical data

Size		DUA-M1	12	22	32	42	52	62	72	82	92	102	112	122
2 pipe														
High speed														
Air flow rate		m ³ /h	315	315	625	625	790	790	980	980	1240	1240	1425	1425
External static pressure		Pa	58	58	58	58	60	60	65	65	60	60	63	63
Cooling capacity	(1)	kW	2,00	2,22	3,60	4,28	4,72	5,36	5,47	5,94	7,11	7,82	7,70	8,62
Sensible capacity	(1)	kW	1,44	1,57	2,70	3,04	3,55	3,84	4,22	4,46	5,36	5,72	5,89	6,38
Water flow-rate	(1)	l/h	345	382	620	737	813	923	942	1023	1225	1347	1326	1485
Water pressur drop	(1)	kPa	20,0	11,0	19,6	31,3	17,7	36,1	23,2	15,6	18,7	15,6	21,7	18,7
Heating capacity	(2)	kW	2,11	2,23	3,98	4,34	5,22	5,42	6,27	6,55	7,58	8,34	8,49	9,42
Water flow-rate	(2)	l/h	363	384	686	748	899	934	1080	1128	1306	1437	1462	1623
Water pressur drop	(2)	kPa	18,0	10,5	18,3	26,2	16,6	28,9	23,0	14,5	16,5	15,0	20,2	18,6
Total power input		W	51	51	94	94	110	110	148	148	145	145	186	186
Medium speed														
Pa														
Air flow rate		m ³ /h	290	290	575	575	720	720	850	850	1120	1120	1270	1270
External static pressure		Pa	50	50	50	50	50	50	50	50	50	50	50	50
Cooling capacity	(1)	kW	1,88	2,07	3,40	4,01	4,42	4,99	4,97	5,36	6,62	7,25	7,11	7,92
Sensible capacity	(1)	kW	1,35	1,46	2,53	2,84	3,30	3,55	3,77	3,97	4,94	5,26	5,37	5,80
Water flow-rate	(1)	l/h	324	357	586	691	761	860	856	923	1140	1249	1225	1364
Water pressur drop	(1)	kPa	17,0	9,7	17,7	27,9	15,7	31,7	19,4	12,9	16,4	13,6	18,8	16,1
Heating capacity	(2)	kW	1,96	2,07	3,70	4,02	4,82	4,99	5,56	5,77	6,96	7,63	7,73	8,52
Water flow-rate	(2)	l/h	338	357	637	692	830	860	958	994	1199	1314	1331	1468
Water pressur drop	(2)	kPa	16,0	9,2	16,1	22,8	14,3	24,9	18,6	11,5	14,2	12,7	17,1	15,6
Total power input		W	45	45	87	87	96	96	122	122	125	125	177	177
Low speed														
Air flow rate		m ³ /h	205	205	395	395	380	380	600	600	580	580	905	905
External static pressure		Pa	25	25	26	26	14	14	23	23	15	15	26	26
Cooling capacity	(1)	kW	1,43	1,54	2,57	2,93	2,68	2,89	3,85	4,10	3,99	4,23	5,58	6,10
Sensible capacity	(1)	kW	1,01	1,07	1,85	2,03	1,90	2,00	2,82	2,95	2,83	2,96	4,06	4,34
Water flow-rate	(1)	l/h	246	265	443	505	462	498	663	706	687	729	961	1051
Water pressur drop	(1)	kPa	11,0	5,6	10,6	15,8	6,3	11,8	12,2	7,9	6,6	5,1	12,2	10,1
Heating capacity	(2)	kW	1,43	1,49	2,67	2,85	2,71	2,76	4,10	4,22	3,94	4,17	5,82	6,30
Water flow-rate	(2)	l/h	246	257	460	491	467	475	706	727	679	718	1002	1085
Water pressur drop	(2)	kPa	9,0	5,1	8,9	12,3	5,1	8,6	10,7	6,6	5,1	4,3	10,3	9,0
Total power input		W	27	27	59	59	50	50	88	88	69	69	155	155
Standard power supply		V/n°/Hz	220-240/1/50											
Type of supply fan	(3)	-	CFG AC											
No. of supply fan		-	1	1	2	2	2	2	2	2	2	2	3	3
H Sound pressure level (supply)	(4)	dB(A)	52	52	56	56	58	58	62	62	60	60	63	63
M Sound pressure level (supply)	(4)	dB(A)	43	43	49	49	51	51	55	55	52	52	56	56
L Sound pressure level (supply)	(4)	dB(A)	50	50	55	55	56	56	59	59	58	58	60	60
H Sound pressure level (return + irradiated)	(4)	dB(A)	42	42	47	47	48	48	52	52	50	50	53	53
M Sound pressure level (return + irradiated)	(4)	dB(A)	42	42	45	45	43	43	51	51	46	46	53	53
L Sound pressure level (return + irradiated)	(4)	dB(A)	34	34	38	38	36	36	44	44	38	38	46	46

(1) Entering exchanger water 7°C (temperature differential 5°C) - Ambient air 27°C D.B. / 19°C W.B.
 (2) Entering exchanger water 45°C (temperature differential 5°C) - Ambient air 20°C

(3) CFG = Centrifugal fan
 (4) Sound levels tested in anechoic chamber and referring to units for 2-pipe systems.

Size		DUA-M1	14	24	34	44	54	64
4 pipe								
High speed								
Air flow rate		m ³ /h	315	625	790	980	1240	1425
External static pressure		Pa	58	58	60	65	60	63
Cooling capacity	(1)	kW	2,00	3,60	4,72	5,47	7,11	7,70
Sensible capacity	(1)	kW	1,44	2,70	3,55	4,22	5,36	5,89
Water flow-rate	(1)	l/h	345	620	813	942	1225	1326
Water pressure drop	(1)	kPa	19,5	19,6	17,7	23,2	18,7	21,7
Heating capacity	(2)	kW	1,76	3,02	3,91	4,49	5,8	6,35
Water flow-rate	(2)	l/h	152	260	337	387	500	547
Water pressure drop	(2)	kPa	7,5	4,8	7,5	9,6	15,3	18,1
Total power input		W	51	94	110	148	145	186
Medium speed								
Air flow rate		m ³ /h	290	575	720	850	1120	1270
External static pressure		Pa	50	50	50	50	50	50
Cooling capacity	(1)	kW	1,88	3,40	4,42	4,97	6,62	7,11
Sensible capacity	(1)	kW	1,35	2,53	3,30	3,77	4,94	5,37
Water flow-rate	(1)	l/h	324	586	761	856	1140	1225
Water pressure drop	(1)	kPa	17,4	17,7	15,7	19,4	16,4	18,8
Heating capacity	(2)	kW	1,66	2,85	3,68	4,10	5,44	5,90
Water flow-rate	(2)	l/h	143	245	317	353	469	508
Water pressure drop	(2)	kPa	6,8	4,3	6,7	8,2	13,7	15,8
Total power input		W	45	87	96	122	125	177
Low speed								
Air flow rate		m ³ /h	205	395	380	600	580	905
External static pressure		Pa	25	26	14	23	15	26
Cooling capacity	(1)	kW	1,43	2,57	2,68	3,85	3,99	5,58
Sensible capacity	(1)	kW	1,01	1,85	1,90	2,82	2,83	4,06
Water flow-rate	(1)	l/h	246	443	462	663	687	961
Water pressure drop	(1)	kPa	10,5	10,6	6,3	12,2	6,6	12,2
Heating capacity	(2)	kW	1,30	2,22	2,38	3,26	3,48	4,72
Water flow-rate	(2)	l/h	112	191	205	281	300	407
Water pressure drop	(2)	kPa	4,4	2,8	3,1	5,4	6,1	10,6
Total power input		W	27	59	50	88	69	155
Standard power supply		V/n°/Hz	220-240/1/50					
Type of supply fan	(3)	-	CFG AC					
No. of supply fan		-	1	2	2	2	2	3
H Sound pressure level (supply)	(4)	dB(A)	52	56	58	62	60	63
M Sound pressure level (supply)	(4)	dB(A)	43	49	51	55	52	56
L Sound pressure level (supply)	(4)	dB(A)	50	55	56	59	58	60
H Sound pressure level (return + irradiated)	(4)	dB(A)	42	47	48	52	50	53
M Sound pressure level (return + irradiated)	(4)	dB(A)	42	45	43	51	46	53
L Sound pressure level (return + irradiated)	(4)	dB(A)	34	38	36	44	38	46

(1) Entering exchanger water 7°C (temperature differential 5°C) - Ambient air 27°C D.B. / 19°C W.B.

(2) Entering exchanger water 65°C (temperature differential 10°C) - Ambient air 20°C

(3) CFG = Centrifugal fan

(4) Sound levels tested in anechoic chamber and referring to units for 2-pipe systems.

Dimensions and connections

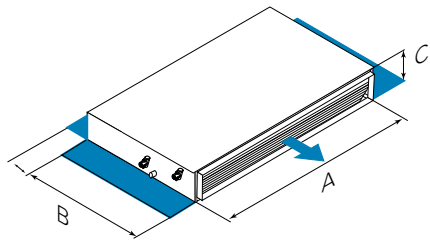

Size	DUE/DUA-M1	12	14	22	24	32	34	42	44	52	54	62	64	72	82	92	102	112	122	
DUA-M1	A - Length	mm	689	689	689	904	904	1119	904	1334	1119	1549	1119	1549	1334	1334	1549	1549	1549	1549
	B - Width	mm	511	511	511	511	511	511	511	511	511	511	511	511	511	511	511	511	511	511
	C - Height	mm	248	248	248	248	248	248	248	248	248	248	248	248	248	248	248	248	248	248
DUE-M1	A - Length	mm	474	474	474	689	689	904	689	1119	904	1549	904	1764	1119	1119	1549	1549	1764	1764
	B - Width	mm	511	511	511	511	511	511	511	511	511	511	511	511	511	511	511	511	511	511
	C - Height	mm	248	248	248	248	248	248	248	248	248	248	248	248	248	248	248	248	248	248
Weight	DUA-M1 - CC2	kg	18,5		19,5		25,4		26,7		26,5		27,9		27,9	29,0	47,2	48,9	47,4	49,1
	DUA-M1 - CC4	kg		19,7		26,9		28,3		29,7		49,5		49,7						
	DUE-M1 - CC2	kg	13,8		14,3		16,9		17,9		22,6		23,6		26,4	27,5	44,5	46,6	48,9	51,6
	DUE-M1 - CC4	kg		14,5		18,1		24,0		28,1		46,7		51,3						

LARICE HP

Water-fed Terminal Unit for Indoor, Horizontal Concealed, Ducted installation

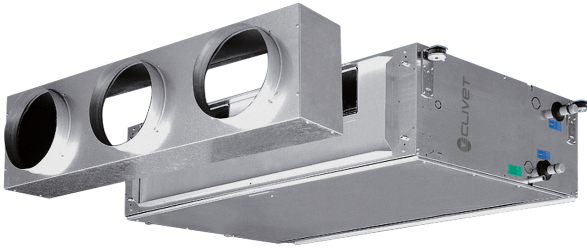

Management and connectivity



Potential-free contact



0-10 V input



Modbus Port (on thermostat)



CONTROL4 NRG management (on thermostat)

Comfort



Hot Cold



Dehumidification



Anti cold air (on thermostat)

Convenience



Auto Restart (on thermostat)

Health



High density filter

- ✓ Extremely slim, can easily be installed even in space-restricted false ceilings
- ✓ Quiet and efficient, thanks to the fan's brushless DC motor
- ✓ Wide range of accessories and configurations to fulfil all installation requirements
- ✓ Unit for horizontal or vertical installation
- ✓ Management via Modbus port with connection to BMS or CONTROL4 NRG

Configurations

TYPE OF SYSTEM:

CC2 2-pipe (Standard)
 CC4 4 pipe

INSTALLATION:

INH Horizontal built-in installation (Standard)







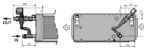

AIR RETURN:

RP From the back / From the bottom (Standard)

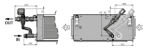
HYDRAULIC CONNECTIONS

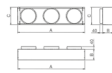
SX Connections on the left (Standard)
 DX Right side fittings

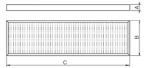
Accessories

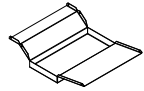
	3V2X	Three-way "on/off" valve kit for main coil for 2-pipese units		HMIFACX	KJRP-86R electronic wired controller for unit or wall-mounting (for AC version)
	3V4OHX	Three-way "on/off" valve kit for additional coil for 4-pipes units		BOXX	Box for wall installation of KJRP-86R user interface
	PCX	Supply/Return air plenum with circular connections		HID-TIFX	Thermostat for fancoil unit with 0-10V port and water probe included (AC/EC fan control)
	FG4X	Synthetic filter Class G4 (ePM10 50%)		HIDE2X	Electro-mechanical thermostat for wall-installation with built-in temperature probe (for AC version)
	BROPX	Auxiliary drain pan (horizontal installation)			

FAN COILS

Dimensions and connections

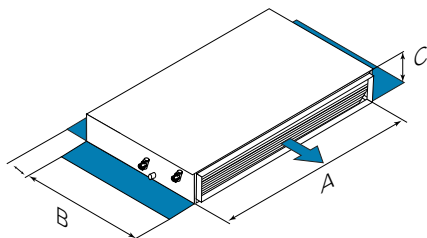

For trouble-free operation of the unit it is essential to maintain the safety distances indicated.

Size	DUE/DUA-H1	12	14	22	24	32	34	42	44	52	54	62	64
DUA-H1	A - Length	mm	1133	1133	1133	1133	1133	1445	1445	1445	1445	1535	1535
DUE-H1	B - Width	mm	698	698	698	698	698	853	853	853	853	1100	1100
	C - Height	mm	255	255	255	255	305	293	293	368	368	421	421
Weight	DUA-H1 - CC2	kg	47		48		56		78		88		124
	DUA-H1 - CC4	kg		50		51		60		83		94	134
	DUE-H1 - CC2	kg	47		48		56		78		88		124
	DUE-H1 - CC4	kg		50		51		60		83		94	134

Technical data

Size		DUE-H1	12	22	32	42	52*	62*
2 pipe								
High speed								
Air flow rate		m ³ /h	1310	1780	2390	3080	3920	5205
External static pressure		Pa	70	85	75	80	70	74
Cooling capacity	(1)	kW	5,61	7,94	10,81	13,99	18,17	24,30
Sensible capacity	(1)	kW	4,72	6,44	8,72	11,23	14,75	20,30
Water flow-rate	(1)	l/h	966	1368	1862	2410	3130	4186
Water pressur drop	(1)	kPa	8,7	15,8	21,6	21,7	21,4	31,8
Heating capacity	(2)	kW	7,76	10,62	13,06	18,08	23,25	29,76
Water flow-rate	(2)	l/h	1337	1829	2250	3114	4005	5126
Water pressur drop	(2)	kPa	13,7	18,8	21,4	23,9	25,4	33,1
Total power input		W	144	225	340	530	609	636
Medium speed								
Air flow rate		m ³ /h	1100	1360	1950	2440	3320	4295
External static pressure		Pa	50	50	50	50	50	50
Cooling capacity	(1)	kW	5,11	6,86	9,70	12,39	16,70	21,91
Sensible capacity	(1)	kW	4,18	5,36	7,61	9,65	13,26	17,79
Water flow-rate	(1)	l/h	880	1182	1671	2134	2877	3774
Water pressur drop	(1)	kPa	7,2	11,8	17,4	16,9	17,9	25,9
Heating capacity	(2)	kW	6,80	8,64	11,25	15,15	20,51	25,83
Water flow-rate	(2)	l/h	1171	1488	1938	2610	3533	4449
Water pressur drop	(2)	kPa	10,7	12,9	16,4	17,4	20,3	25,6
Total power input		W	88	110	195	253	383	330
Low speed								
Air flow rate		m ³ /h	780	940	1380	1840	2400	2825
External static pressure		Pa	26	24	25	28	25	22
Cooling capacity	(1)	kW	4,14	5,44	7,87	10,47	13,73	16,91
Sensible capacity	(1)	kW	3,24	4,08	5,93	7,90	10,46	12,84
Water flow-rate	(1)	l/h	713	937	1356	1803	2365	2913
Water pressur drop	(1)	kPa	4,9	7,7	11,7	12,2	12,3	15,9
Heating capacity	(2)	kW	5,18	6,42	8,64	12,13	15,90	18,63
Water flow-rate	(2)	l/h	892	1106	1488	2089	2739	3209
Water pressur drop	(2)	kPa	6,5	7,5	10,1	11,6	12,8	14,2
Total power input		W	40	44	80	110	166	106
Standard power supply		V/n ² /Hz				220-240/1/50		
Type of supply fan	(3)	-				CFG EC		
No. of supply fan		-	2	2	2	2	2	2
H Sound pressure level (supply)	(4)	dB(A)	61	63	66	69	73	75
M Sound pressure level (supply)	(4)	dB(A)	59	61	64	67	71	73
L Sound pressure level (supply)	(4)	dB(A)	55	57	62	64	70	72
H Sound pressure level (return + irradiated)	(4)	dB(A)	52	55	60	62	67	69
M Sound pressure level (return + irradiated)	(4)	dB(A)	48	48	55	58	61	60
L Sound pressure level (return + irradiated)	(4)	dB(A)	45	45	52	55	58	57

(1) Entering exchanger water 7°C (temperature differential 5°C) - Ambient air 27°C D.B. / 19°C W.B.

(2) Entering exchanger water 45°C (temperature differential 5°C) - Ambient air 20°C

(3) CFG = Centrifugal fan

(4) Sound levels tested in anechoic chamber and referring to units for 2-pipe systems.

* Sizes not covered by Eurovent certification

Size		DUE-H1	14	24	34	44	54*	64*
4 pipe								
High speed								
Air flow rate		m ³ /h	1264	1750	2350	3040	3858	5140
External static pressure		Pa	70	85	75	80	70	74
Cooling capacity	(1)	kW	5,98	7,87	10,70	13,90	19,38	24,10
Sensible capacity	(1)	kW	4,61	6,35	8,61	11,13	15,12	20,09
Water flow-rate	(1)	l/h	1053	1356	1843	2394	3436	4151
Water pressur drop	(1)	kPa	3,9	15,5	21,2	21,4	10,7	31,4
Heating capacity	(2)	kW	4,80	6,25	8,02	10,75	14,25	34,54
Water flow-rate	(2)	l/h	431	538	691	926	1295	2975
Water pressur drop	(2)	kPa	12,2	26,4	17,3	33,0	31,4	41,3
Total power input		W	144	225	340	530	609	661
Medium speed								
Air flow rate		m ³ /h	1040	1340	1920	2400	3300	4235
External static pressure		Pa	50	50	50	50	50	50
Cooling capacity	(1)	kW	4,94	6,79	9,59	12,27	16,62	21,71
Sensible capacity	(1)	kW	4,01	5,30	7,51	9,53	13,19	17,59
Water flow-rate	(1)	l/h	851	1170	1652	2113	2863	3740
Water pressur drop	(1)	kPa	6,8	11,6	17,1	16,6	16,3	25,4
Heating capacity	(2)	kW	4,18	5,42	7,20	9,48	12,67	30,58
Water flow-rate	(2)	l/h	360	467	620	816	1091	2634
Water pressur drop	(2)	kPa	13,4	20,4	14,3	26,3	25,7	33,2
Total power input		W	88	115	200	253	384	343
Low speed								
Air flow rate		m ³ /h	750	920	1350	1810	2428	2629
External static pressure		Pa	26	24	25	28	25	22
Cooling capacity	(1)	kW	4,04	5,36	7,76	10,36	14,38	14,94
Sensible capacity	(1)	kW	3,14	4,01	5,83	7,79	10,79	10,75
Water flow-rate	(1)	l/h	696	923	1337	1785	2500	2588
Water pressur drop	(1)	kPa	4,9	7,5	11,4	12,0	6,1	5,6
Heating capacity	(2)	kW	3,43	4,33	5,90	8,06	10,88	22,98
Water flow-rate	(2)	l/h	295	373	508	694	962	1979
Water pressur drop	(2)	kPa	9,4	13,6	9,9	19,6	18,4	19,8
Total power input		W	40	44	80	110	164	124
Standard power supply		V/n ² /Hz	220-240/1/50					
Type of supply fan	(3)	-	CFG EC					
No. of supply fan		-	2	2	2	2	2	2
H Sound pressure level (supply)	(4)	dB(A)	61	63	66	69	73	75
M Sound pressure level (supply)	(4)	dB(A)	59	61	64	67	71	73
L Sound pressure level (supply)	(4)	dB(A)	55	57	62	64	70	72
H Sound pressure level (return + irradiated)	(4)	dB(A)	52	55	60	62	67	69
M Sound pressure level (return + irradiated)	(4)	dB(A)	48	48	55	58	61	60
L Sound pressure level (return + irradiated)	(4)	dB(A)	45	45	52	55	58	57

(1) Entering exchanger water 7°C (temperature differential 5°C) - Ambient air 27°C D.B. / 19°C W.B.
 (2) Entering exchanger water 65°C (temperature differential 10°C) - Ambient air 20°C

(3) CFG = Centrifugal fan
 (4) Sound levels tested in anechoic chamber and referring to units for 2-pipe systems.
 * Sizes not covered by Eurovent certification

Technical data

Size		DUA-H1	12	22	32	42	52*	62*
2 pipe								
High speed								
Air flow rate		m ³ /h	1734	1825	2440	3020	3850	5062
External static pressure		Pa	75	80	70	67	70	70
Cooling capacity	(1)	kW	8,89	8,16	10,70	13,60	17,76	25,31
Sensible capacity	(1)	kW	6,58	6,62	8,65	10,90	14,37	19,74
Water flow-rate	(1)	l/h	1590	1406	1843	2343	3059	4608
Water pressur drop	(1)	kPa	8,9	17,0	23,0	21,0	19,4	15,3
Heating capacity	(2)	kW	7,67	10,10	13,13	16,53	22,93	29,60
Water flow-rate	(2)	l/h	1321	1740	2351	2847	3950	5350
Water pressur drop	(2)	kPa	11,3	18,3	15,0	21,3	22,8	16,9
Total power input		W	358	285	470	570	760	1334
Medium speed								
Air flow rate		m ³ /h	801	1410	2075	2580	3280	3546
External static pressure		Pa	50	50	50	50	50	50
Cooling capacity	(1)	kW	4,83	7,01	9,76	12,40	16,19	20,06
Sensible capacity	(1)	kW	3,53	5,48	7,68	9,70	12,80	15,04
Water flow-rate	(1)	l/h	856	1207	1681	2136	2789	3600
Water pressur drop	(1)	kPa	3,8	13,0	20,0	18,0	16,3	10,1
Heating capacity	(2)	kW	6,44	8,27	11,80	14,92	20,32	22,47
Water flow-rate	(2)	l/h	1109	1425	2033	2570	3500	4507
Water pressur drop	(2)	kPa	8,2	12,7	20,2	17,7	18,3	10,2
Total power input		W	152	230	420	490	617	909
Low speed								
Air flow rate		m ³ /h	790	840	1710	2070	2740	2127
External static pressure		Pa	25	15	30	35	35	35
Cooling capacity	(1)	kW	4,17	4,99	8,71	10,90	14,54	13,70
Sensible capacity	(1)	kW	3,25	3,66	6,67	8,25	11,21	10,00
Water flow-rate	(1)	l/h	718	860	1500	1878	2505	2473
Water pressur drop	(1)	kPa	5,0	7,0	16,0	14,0	13,3	5,2
Heating capacity	(2)	kW	4,98	5,57	10,43	12,79	17,67	14,57
Water flow-rate	(2)	l/h	858	959	1868	2203	3044	2639
Water pressur drop	(2)	kPa	5,2	6,2	9,9	13,4	13,3	4,8
Total power input		W	115	170	350	390	500	693
Standard power supply		V/n°/Hz	220-240/1/50					
Type of supply fan	(3)	-	CFG AC					
No. of supply fan		-	2	2	2	2	2	2
H Sound pressure level (supply)	(4)	dB(A)	60	64	67	68	72	76
M Sound pressure level (supply)	(4)	dB(A)	58	61	65	66	70	73
L Sound pressure level (supply)	(4)	dB(A)	55	59	64	65	69	70
H Sound pressure level (return + irradiated)	(4)	dB(A)	52	56	62	63	67	67
M Sound pressure level (return + irradiated)	(4)	dB(A)	47	47	60	61	65	62
L Sound pressure level (return + irradiated)	(4)	dB(A)	44	44	57	59	63	63

(1) Entering exchanger water 7°C (temperature differential 5°C) - Ambient air 27°C D.B. / 19°C W.B.

(2) Entering exchanger water 45°C (temperature differential 5°C) - Ambient air 20°C

(3) CFG = Centrifugal fan

(4) Sound levels tested in anechoic chamber and referring to units for 2-pipe systems.

* Sizes not covered by Eurovent certification

Size		DUA-H1	14	24	34	44	54*	64*
4 pipe								
High speed								
Air flow rate		m ³ /h	1350	1775	2390	2960	3800	4993
External static pressure		Pa	75	80	70	67	70	70
Cooling capacity	(1)	kW	5,79	8,03	10,58	13,47	16,73	25,79
Sensible capacity	(1)	kW	4,87	6,49	8,51	10,72	13,56	19,86
Water flow-rate	(1)	l/h	997	1383	1822	2320	2882	4658
Water pressur drop	(1)	kPa	9,0	16,0	23,0	20,0	17,4	15,8
Heating capacity	(2)	kW	4,81	6,30	8,08	10,60	13,64	35,13
Water flow-rate	(2)	l/h	414	543	696	913	1175	3175
Water pressur drop	(2)	kPa	17,5	26,3	18,1	33,9	38,4	22,5
Total power input		W	185	275	460	570	760	1310
Medium speed								
Air flow rate		m ³ /h	1090	1390	2045	2545	3245	3531
External static pressure		Pa	50	50	50	50	50	50
Cooling capacity	(1)	kW	5,11	6,96	9,67	12,34	15,31	20,52
Sensible capacity	(1)	kW	4,16	5,42	7,60	9,61	12,13	15,34
Water flow-rate	(1)	l/h	880	1199	1666	2126	2637	3600
Water pressur drop	(1)	kPa	7,0	13,0	19,0	17,0	14,7	10,4
Heating capacity	(2)	kW	4,29	5,53	7,44	9,95	12,55	27,97
Water flow-rate	(2)	l/h	369	476	641	857	1081	2516
Water pressur drop	(2)	kPa	14,2	20,8	15,6	29,9	32,9	14,8
Total power input		W	155	225	415	490	617	894
Low speed								
Air flow rate		m ³ /h	770	840	1680	2055	2700	2117
External static pressure		Pa	25	15	30	35	35	35
Cooling capacity	(1)	kW	4,09	4,99	8,61	10,85	13,75	13,99
Sensible capacity	(1)	kW	3,18	3,66	6,58	8,21	10,62	10,07
Water flow-rate	(1)	l/h	705	860	1483	1869	2368	2520
Water pressur drop	(1)	kPa	5,0	7,0	15,7	13,8	12,0	5,4
Heating capacity	(2)	kW	3,49	4,09	6,70	8,95	11,34	19,34
Water flow-rate	(2)	l/h	301	352	577	771	977	1746
Water pressur drop	(2)	kPa	9,8	12,0	12,9	24,6	27,4	7,7
Total power input		W	115	170	345	390	500	689
Standard power supply		V/n°/Hz	220-240/1/50					
Type of supply fan	(3)	-	CFG AC					
No. of supply fan		-	2	2	2	2	2	2
H Sound pressure level (supply)	(4)	dB(A)	60	64	67	68	72	76
M Sound pressure level (supply)	(4)	dB(A)	58	61	65	66	70	73
L Sound pressure level (supply)	(4)	dB(A)	55	59	64	65	69	70
H Sound pressure level (return + irradiated)	(4)	dB(A)	52	56	62	63	67	67
M Sound pressure level (return + irradiated)	(4)	dB(A)	47	47	60	61	65	62
L Sound pressure level (return + irradiated)	(4)	dB(A)	44	44	57	59	63	63

(1) Entering exchanger water 7°C (temperature differential 5°C) - Ambient air 27°C D.B. / 19°C W.B.
 (2) Entering exchanger water 65°C (temperature differential 10°C) - Ambient air 20°C

(3) CFG = Centrifugal fan
 (4) Sound levels tested in anechoic chamber and referring to units for 2-pipe systems.
 * Sizes not covered by Eurovent certification

Heat pump for DHW



4.1 Heat pump for DHW



AQUA F 100 L



AQUA F 190-300 L

AQUA F 100L

Packaged monoblock heat pump for domestic hot water production



Energy saving



Solar integration

Comfort



DHW

Reliability



Backup heater



025

Health



Renewable Energy

Convenience



Integrated DHW tank

Management and connectivity



Input ON/
OFF



Port
Modbus



Control
via App



management
Control4 NRG

- ✓ Advanced connectivity: management via the App or via the Modbus port with CONTROL4 NRG included as standard
- ✓ Equipped as standard with electronic anode, photovoltaic contacts
- ✓ Operation with heat pump only with the outdoor air between -7°C and 43°C
- ✓ Market-leading A+ efficiency class

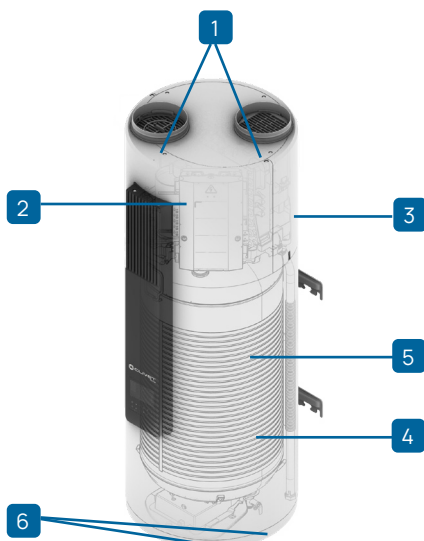

- 1 AC fan
- 2 Rotary compressor
- 3 Air-gas finned exchanger
- 4 DHW tank
- 5 Microchannel exchanger (wound around the tank)
- 6 Electronic anode kit + safety/auxiliary heater

TOP efficiency

AQUA F attains the highest levels of efficiency on the market today. Thanks to the careful design of the refrigerant circuit, it achieves class A+ according to the ErP directive. The high COP values allow great savings in terms of energy and operating costs, in addition to an increase in the use of renewable energy.

Accessories



CMPX

Optional connection cables for ON/OFF contacts, Modbus, and Photovoltaic

Dimensions and connections

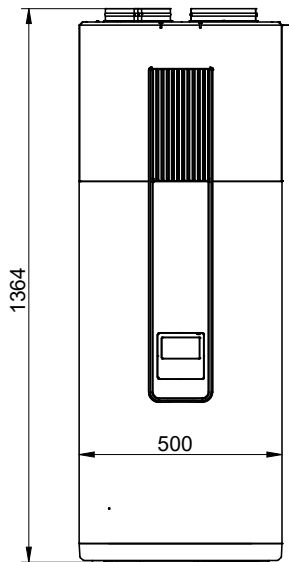

Size		100	
Dimensions	AxCxB	mm	500x1.364x500
Operating weight		kg	161
Refrigerant charge		type / GWP	R-290 / 0.02
		kg	1,10
		CO ₂ tons	1,57
External diameters	Air	mm	160
	Water	inch	3/4"
	Condensate drain	mm	10

Technical data

Size		100L		
DHW	Heating capacity		kW	0,98
	COP	Water 15/45 °C Outdoor air 15 °C DB/87% UR	-	3,8
	Heating time		h:min	03:30
	Heating capacity	Water 15/65 °C Outdoor air 43 °C DB/87% UR	kW	1,44
	COP		-	3,65
	Nominal tank volume		l	98
Electrical power for meter sizing			kW	1,95
Power heater			kW	1,50
Seasonal efficiency Medium climate	DHW	Energy class	-	A+
		Annual energy consumption	kWh/year	463
		Withdrawal profile	-	M
		ns (seasonal output)	%	111

Technical specifications

Fan	Air flow rate	Nominal	m ³ /h	200
	Available pressure	Water content	Pa	60
Sound power		Water content	dB(A)	54
Sound pressure @1m		Water content	dB(A)	43
Tank insulation		Material / Medium Thickness ¹	-	CP / 42mm
Thermal dispersions			W/K	18,2
Solar pipe coil		Surface	m ²	-
Maximum operating pressure			bar	-
Power supply		Voltage/Frequency/Phases	V/Hz/n°	230/50/1

Operating range

Water temperature	Minimum / Maximum	°C	10 / 70
Operating Voltage Range Outdoor air	Minimum / Maximum	°C	-20 / 43

1. Inlet water temperature 15°C, storage set 45°C, source air 15°C D.B/12°C W.B.
2. The product conforms with the European ErP Directives, which include Commission Delegated Regulation (EU) no. 812/2013, Commission Delegated Regulation no. 814/2013, Clima Average, Heat Pump Water Heater
3. The product conforms with the European ErP Directives, which include Commission Delegated Regulation (EU) no. 812/2013, Commission Delegated Regulation no. 814/2013, Clima Average, Heat Pump Water Heater
4. The product conforms with the European ErP Directives, which include Commission

- Delegated Regulation (EU) no. 812/2013, Commission Delegated Regulation no. 814/2013, Clima Average, Heat Pump Water Heater
5. Data for fully ducted unit.

*Contains fluorinated greenhouse gases

AQUA F 190-300L

Packaged monoblock heat pump for domestic hot water production



ENERGY SAVING



Solar integration



Smart Grid Ready

Comfort



DHW

RELIABILITY



Backup heater



025

HEALTH



Renewable Energy

CONVENIENCE



Integrated DHW tank

Management and connectivity



Input ON/OFF



Port Modbus



Control via App



management Control4 NRG

- ✓ Advanced connectivity: management via the App or via the Modbus port with CONTROL4 NRG included as standard
- ✓ Equipped as standard with electronic anode, photovoltaic contacts and Smart Grid
- ✓ Operation with heat pump only with the outdoor air between -7°C and 43°C
- ✓ Market-leading A+ efficiency class

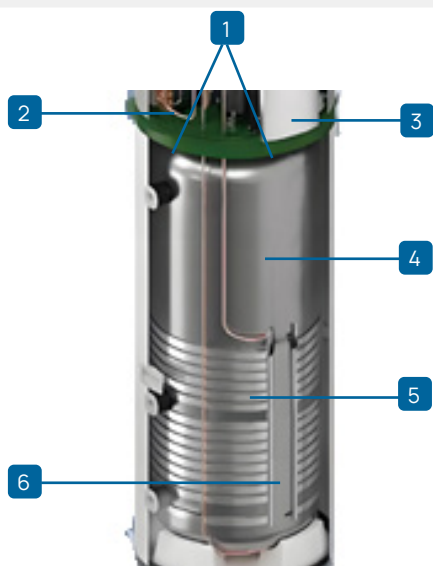

- 1 AC fan
- 2 Rotary compressor
- 3 Air-gas finned exchanger
- 4 DHW tank
- 5 Microchannel exchanger (wound around the tank)
- 6 Electronic anode kit + safety/auxiliary heater

Low maintenance

Thanks to the electronic anode and the automatic malfunction detection system, there is no need to periodically empty the water in the heat pump to check the condition of the anode.

Maintenance of the product is therefore limited to checking the filters, thus facilitating a rapid, inexpensive and non-invasive response.

Accessories



CCAX

Optional connection cable for cascade management



CA200X

Adattatore per collegare un canale d'aria da Ø200mm su connessione da Ø190mm (per kit completo ordinare 2 pezzi)

Dimensions and connections

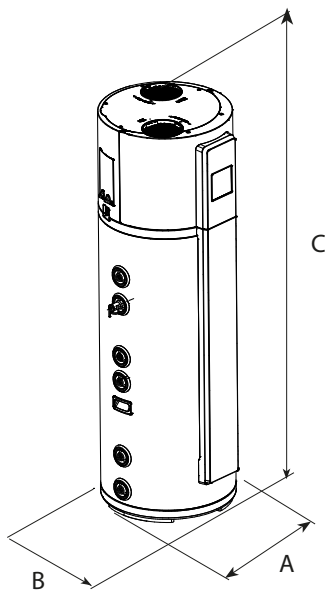

Size			190	190S	300	300S
Dimensions	AxCxB	mm	560x1.735x560		660x1.985x660	
Operating weight		kg	274	285	396	407
Refrigerant charge		type / GWP	R-290 / 0.02			
		kg	1,10		1,50	
		CO ₂ tons	1,57		2,15	
External diameters	Air	mm	160		190	
	Water	inch	3/4"			
	Condensate drain	mm	10			

Technical data

Size				190	190S	300	300S
DHW	Heating capacity		kW	1,26	1,24	1,59	1,57
	COP	Water 15/45 °C Outdoor air 15 °C DB/87% UR	-	3,61	3,49	3,65	3,62
	Heating time		h:min	05:31	05:26	06:03	06:10
	Heating capacity	Water 15/65 °C Outdoor air 43 °C DB/87% UR	kW	1,93	1,90	2,35	2,32
	COP		-	5,31	5,28	5,18	5,11
	Nominal tank volume		l	185	180	275	270
Electrical power for meter sizing			kW	2,24	2,24	2,35	2,35
Power heater			kW	1,64	1,64	1,64	1,64
Seasonal efficiency Medium climate	DHW	Energy class	-	A+	A+	A+	A+
		Annual energy consumption	kWh/year	800	861	1.254	1.328
		Withdrawal profile	-	L	L	XL	XL
		ns (seasonal output)	%	128	119	134	126
Technical specifications							
Fan	Air flow rate	Nominal	m ³ /h	340	340	390	390
	Available pressure	Water content	Pa	55	55	55	55
Sound power		Water content	dB(A)	55	55	56	56
Sound pressure @1m		Water content	dB(A)	43	43	42	42
Tank insulation		Material / Medium Thickness ¹	-	PU+ / 43mm	PU+ / 43mm	PU+ / 46mm	PU+ / 46mm
Thermal dispersions			W/K	1,47	1,47	1,53	1,53
Solar pipe coil		Surface	m ²	-	0,84	-	0,84
Maximum operating pressure			bar	8,5	8,5	8,5	8,5
Power supply		Voltage/Frequency/Phases	V/Hz/n°	230/50/1	230/50/2	230/50/3	230/50/4
Operating range							
Water temperature		Minimum / Maximum	°C	10 / 70	10 / 70	10 / 70	10 / 70
Operating Voltage Range Outdoor air		Minimum / Maximum	°C	-20 / 43	-20 / 43	-20 / 43	-20 / 43

1. Inlet water temperature 15°C, storage set 45°C, source air 15°C D.B/12°C W.B.
2. The product conforms with the European ErP Directives, which include Commission Delegated Regulation (EU) no. 812/2013, Commission Delegated Regulation no. 814/2013, Clima Average, Heat Pump Water Heater
3. The product conforms with the European ErP Directives, which include Commission Delegated Regulation (EU) no. 812/2013, Commission Delegated Regulation no. 814/2013, Clima Average, Heat Pump Water Heater

4. The product conforms with the European ErP Directives, which include Commission Delegated Regulation (EU) no. 812/2013, Commission Delegated Regulation no. 814/2013, Clima Average, Heat Pump Water Heater
5. Data for fully ducted unit.

*Contains fluorinated greenhouse gases

VMC with recovery

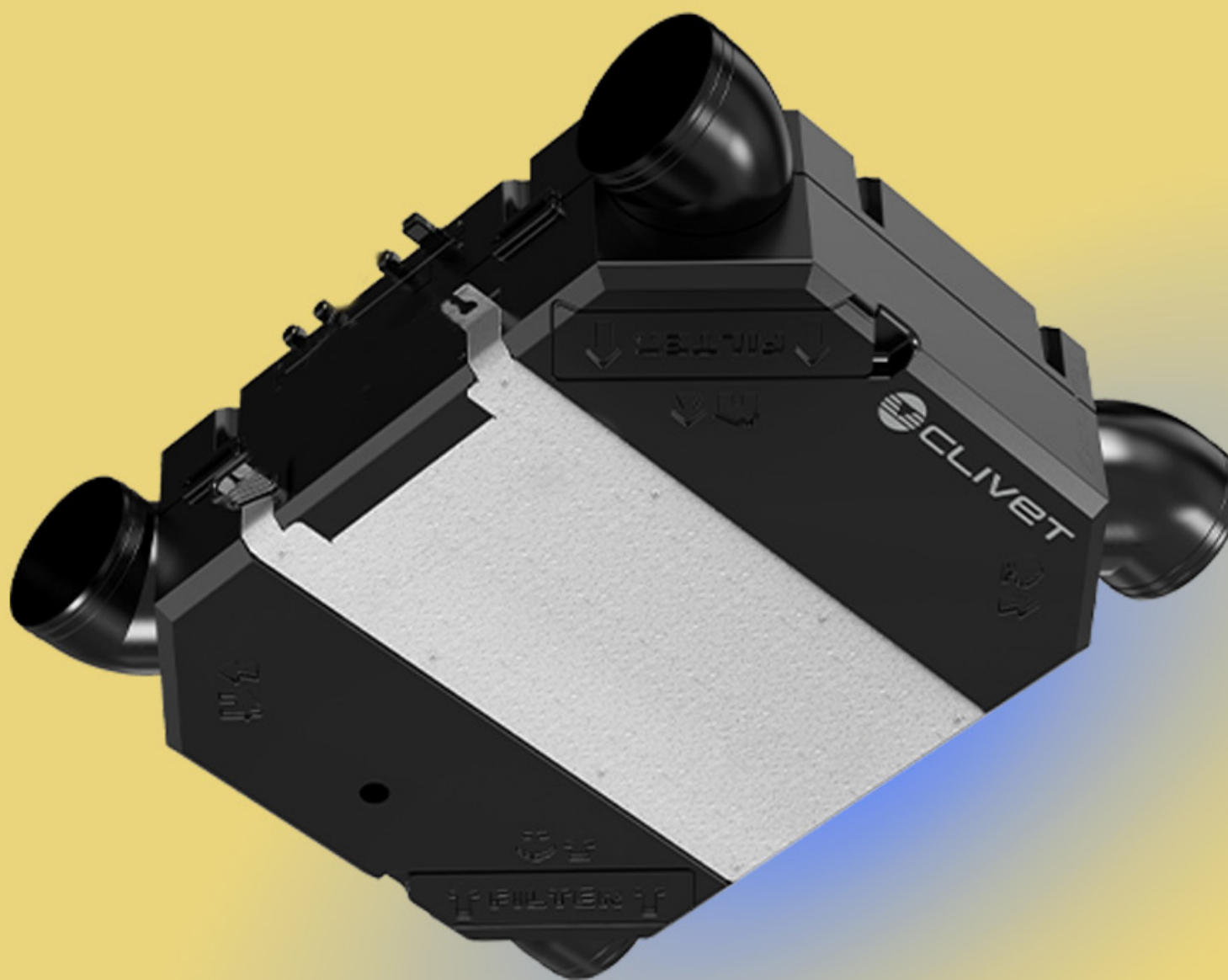

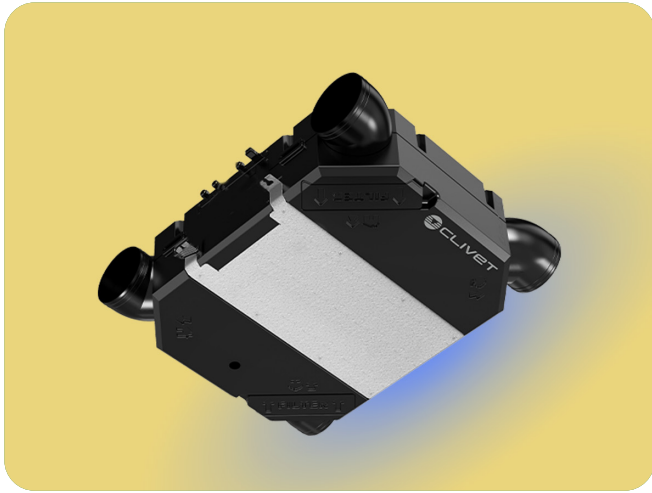

ELFOFRESH EVO

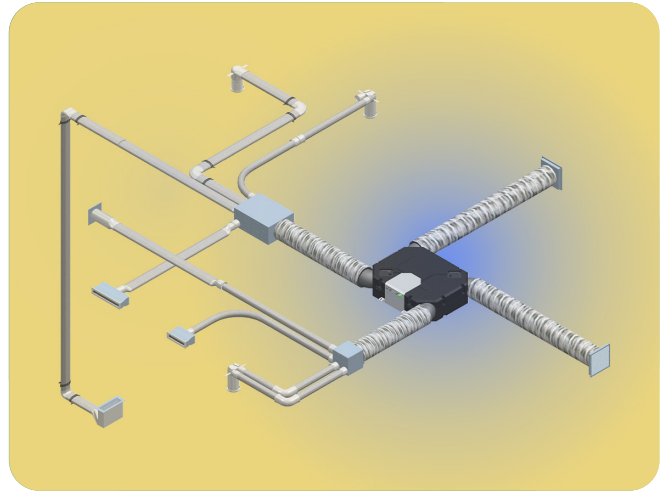

AIRPATH

ELFOFRESH EVO

Mechanical ventilation unit with thermodynamic heat recovery



Energy saving



Solar integration (DHW tank - optional)



Cascade



€-Switch

Comfort



Hot Cold



DHW



Silent

Convenience



Weekkey Timer



Instant DHW (Hybrid Version)



Contemporaneity (Hybrid Version)



Integrated DHW tank

Management and connectivity



Input ON/ OFF



Port Modbus



Control via App



management CONTROL4 NRG



User interface / thermostat



Clivet Eye monitoring

Reliability



Backup heater (optional)

- ✓ Innovative heat recovery system that alone fulfils over 85% of the building's demands
- ✓ Air humidity control
- ✓ Purifies the air with the high efficiency electrostatic filter (optional)
- ✓ Inverter DC compressor and constant flow DC fan for the best modulation operation
- ✓ SmartHome App or via the Modbus port with CONTROL4 NRG standard supplied

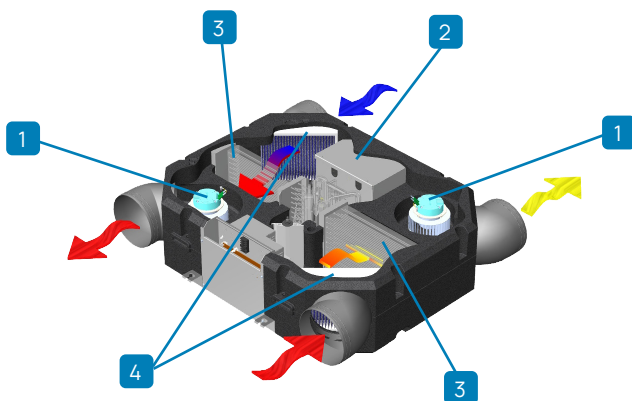

- 1 DC inverter fan with constant flow
- 2 Inverter DC rotary compressor
- 3 Air-gas finned exchanger
- 4 Air filter

Heats or cools for free

As well as renewing and purifying the ambient air, ELFOFRESH EVO is a real support for the main heating and cooling generator. Alone, it can fulfil up to 85% of the thermal demands of the house, whereas a traditional passive recuperator can typically only contribute between 10% (in summer) and 45% (in winter).

In spring or autumn, when the weather is mild, ELFOFRESH EVO works mainly in Free Cooling / Heating: it only uses the thermal content of outdoor air for air conditioning, working at virtually zero (energy and economic) cost.

Chosen during design, ELFOFRESH EVO allows a smaller generator to be used: less space and cheaper!

Configurations

TYPE OF INSTALLATION:

- false ceiling (standard)
- EI in-view installation

AIR FILTRATION:

- Standard filter (standard)
- FIFD Electronic filter with iFD technology (ISO 16890 ePM1 90%)

Technical data

Size				Size 2					
				125	150	210	270	320	
Ventilation	Settable air flow			m ³ /h					
	Available pressure	Nominal / Maximum		Pa			50 / 120		
	Fresh Air			-			100%		
	Filters type			-			Folded filter		
	Filtration class			-			PM10 50%		
Winter recovery	Heating capacity	Ambient Air 20 °C/50% UR		kW	1,42	1,55	1,86	2,05	2,49
	COP	Outdoor air 7 °C/6°C WB		-	3,09	3,69	4,13	4,93	4,61
	Heating capacity	Ambient Air 20 °C/50% UR		kW	1,97	2,1	2,21	2,37	2,45
	COP	Outdoor air -5 °C/80% UR		-	4,93	4,04	4,7	6,5	7,66
Summer recovery	Cooling capacity	Ambient Air 27 °C/50% UR		kW	1,57	1,64	1,73	1,92	2,23
	EER	Outdoor air 35 °C/40% UR		-	4,34	3,15	3,26	3,5	2,77
Electrical power for meter sizing				kW	1,08				
Power supply		Voltage/Frequency/Phases		V/Hz/n°	230/50/1				
Sound power		Minimum / Maximum		dB(A)	47 / 58				
Sound pressure @1 m		Minimum / Maximum		dB(A)	34 / 45				
Operating range									
Operating range (indoor air)	Heating	Minimum / Maximum		°C	15 / 30				
	Cooling	Minimum / Maximum		°C	16 / 30				
Operating range (outdoor air)	Heating	Minimum / Maximum		°C	-20 / 28				
	Cooling	Minimum / Maximum		°C	16 / 45				

Data according to EN 14511: 2022 and referred to available pressure of 50 Pa.

Dimensions and connections

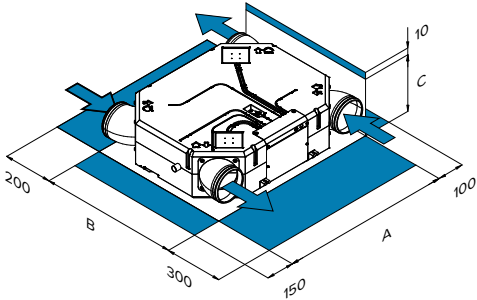

For trouble-free operation of the unit it is essential to maintain the safety distances indicated.

Size			Size 2	
Dimensions	AxCxB	mm	1107x290x900	
Weight		kg	44	
Refrigerant charge		tipo / GWP	R-32 / 675	
		kg	0,30	
		CO ₂ tons	0,20	
External diameters	Air	mm	200	
	Condensate drain	mm	32	

System diagrams

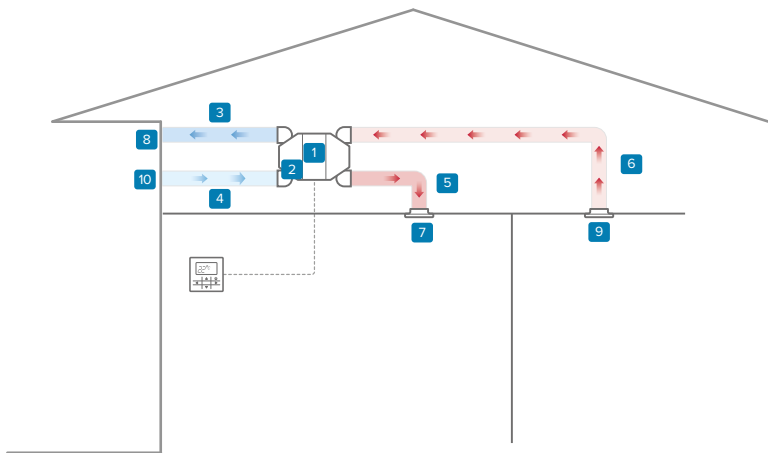

Air renewal system

- 1 Ventilation heatpump with heat recovery
- 2 Integrated electrostatic filter (optional)
- 3 Exhaust air duct (optional)
- 4 Outdoor air duct (optional)
- 5 Intake air duct (optional)
- 6 Extracted air duct (optional)
- 7 Supply grille (optional)
- 8 Exhaust grille (optional)
- 9 Extraction grille (optional)
- 10 Outdoor air grille (optional)

Note: for the distribution system in detail see the ELFOAir section

AIRPATH

Air distribution system

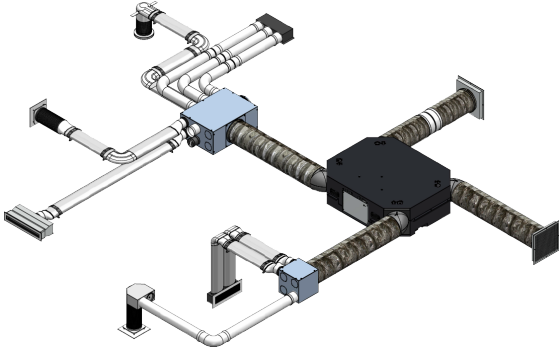











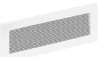































- ✓ Compatible with FULLNESS, ELFOFRESH EVO, and FRESH LARGE EVO Size 1
- ✓ Flexible in installation thanks to the use of flexible and usable ducts
- ✓ Simple in selecting the components and in the installation
- ✓ Air quality assured by the use of antistatic and antibacterial ducts
- ✓ Homogenous air diffusion thanks to the special diffusers AIRJET
- ✓ Wide range of internal grilles for the supply and intake of air

ANTISTATIC AND ANTIBACTERIAL

The details indicate the quality of the AIRPATH system. The inner surface of the flexible ducts is coated with a special antistatic and antibacterial plastic film to ensure maximum hygiene of the fresh air. Furthermore the internal smooth surface of the ducts ensures low pressure drops and therefore reduces consumptions for ventilation.

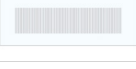
Accessories

	DAIR50X	AIRJET 50/I supply diffuser - white frame and black inside
	DAIR80X	AIRJET 80/I supply diffuser - white frame and black inside
	GAIR50X	Intake grille + extractable filter AIRJET 50/A - white frame and black inside
	GAIR80X	Intake grille + extractable filter AIRJET 80/A - white frame and black inside
	PAIR50X	Suction/supply plenum with AIRJET 50 control damper - rear connection
	PAIR80X	Suction/supply plenum with AIRJET 80 control damper - rear connection
	GAVEX	White rectangular perforated supply/intake grille 350x130mm
	GIVEX	White rectangular die-cut supply/intake grille 350x130mm
	FREQ	Filter for rectangular grilles 350x130mm (box of 5 pieces)
	TACRX	DN125 adjustable circular air terminal in ABS with rear deflector and mounting bracket included
	FT125X	Filter for DN125 air terminal (box of 5 pieces)
	VIQX	DN125 adjustable square air terminal in ABS with mounting bracket included
	TFT90X	DN90 round flexible tube in a 50m coil
	ITTX	Insulation for DN90 round hose in coils of 15m
	CBT90X	Connector to distribution box for DN90 round tube
	GIUTX	Connecting joint for DN90 round tube
	CT90X	Printed curve of 90-degree angle for DN90 round tube
	A90DTX	Flat single-hose 90° adapter for DN125 air terminal
	TACTX	Cap for DN90 round hose (5 pieces)
	ANFTX	DN90 O-Ring seal (box of 10 pieces)
	REGPX	DN90 constant automatic flow-rate controller, range 20-50 m ³ /h
	BD14CX	Distribution box of DN200 joint with 14 connections
	BD8CX	DN200 distribution box with 8 connections
	GIU150X	M/M coupling for 150 pipe
	GIU200X	M/M coupling for 200 mm pipe
	GIU250X	M/M coupling for 250 mm pipe
	TFPNX	132x52mm hose in coils of 20m

	ITPX	Insulation in 20 m coils for 132x52 mm flat hose
	COBPX	Connector to distribution box for flat tube
	GIUPX	Connection joint and seal for flat hose (box of 10 pieces)
	CVP90X	Vertical 90-degree curve for flat tube
	COP90X	Horizontal 90-degree curve for flat tube
	CTP180X	Joint for 180-degree flat tube rotation
	R2520X	DN250-DN200 Reducer
	R150X	DN200-DN150 Reducer
	RTPTX	Round/flat tube connecting joint
	ANFPX	Fixing ring for flat hose (box of 10 pieces)
	A90GP2X	90° flat dual-hose adapter for 350x130mm flat grille
	A90GP3X	Round hose adapter with 3 90° connections for 350x130 mm flat grille
	ADMPX	Flat single-hose straight adapter for DN125 air terminal
	A90DPX	DN90 round double-hose 90° adapter for DN125 air terminal + cap
	DY200X	DN200-DN200-DN200 Y-branch
	DY250X	DN250-DN200-DN200 Y-branch
	GIBEX	Brushed stainless steel supply/intake grille 350x130mm of aesthetic design with linear slots
	GABEX	Rectangular brushed stainless steel supply/intake grille 350x130mm of aesthetic design with circular slots
	GIDEX	White rectangular supply/intake grille 350x130mm of aesthetic design with linear slots
	GADEX	White rectangular supply/intake grille 350x130mm of aesthetic design with circular slots
	TFIS200X	Exhaust / return square wall grig with circular coupling DN200
	PA90GP2X	Adapter extension for 350x130 mm flat grilles

SOLUTIONS

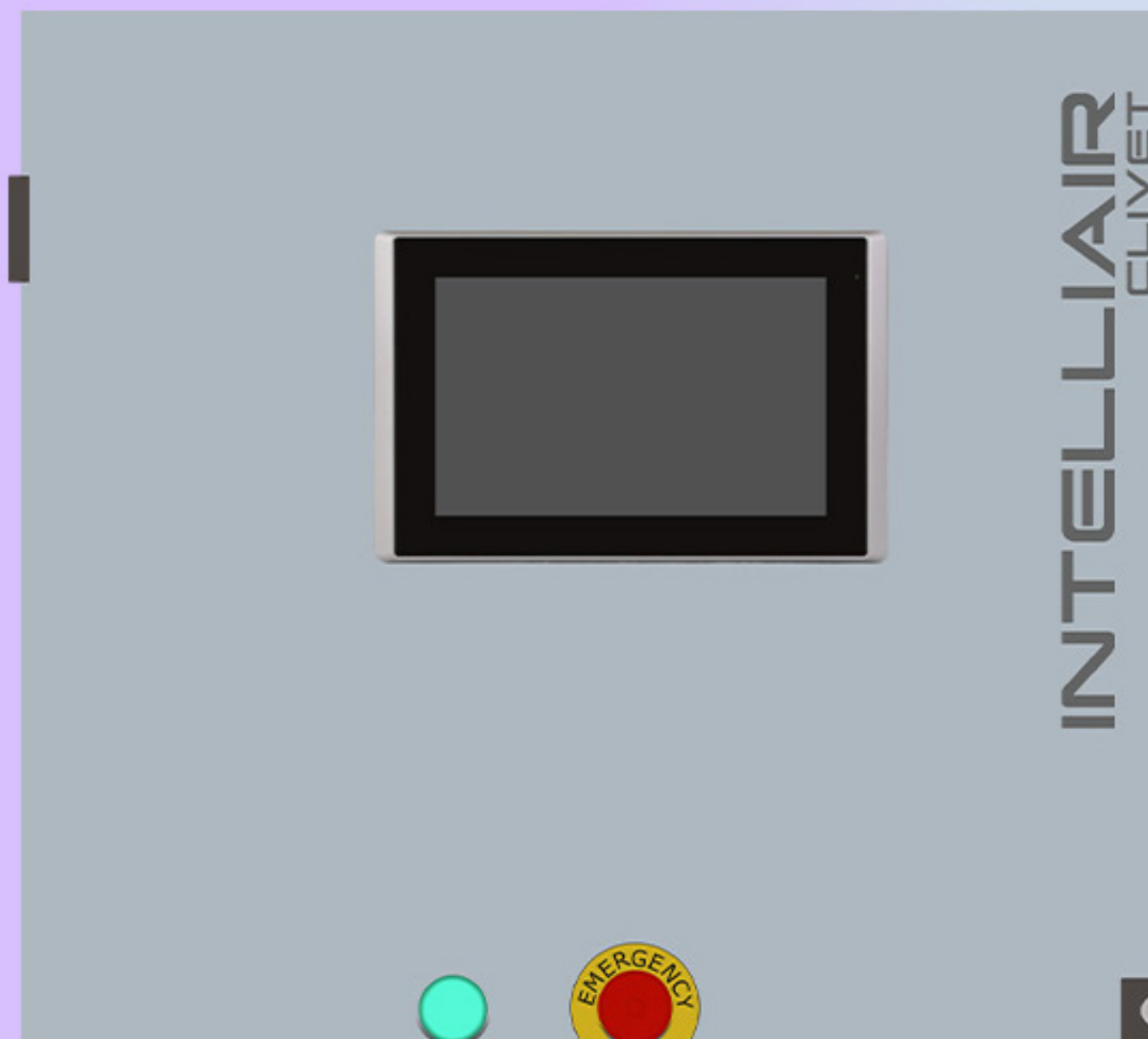

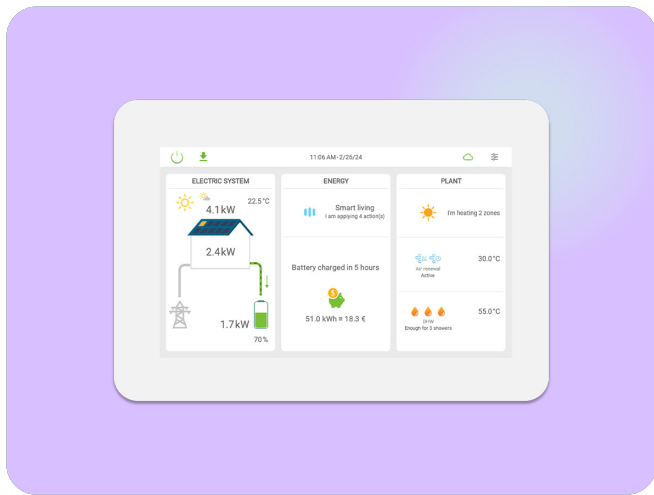

CONTROL4 NRG

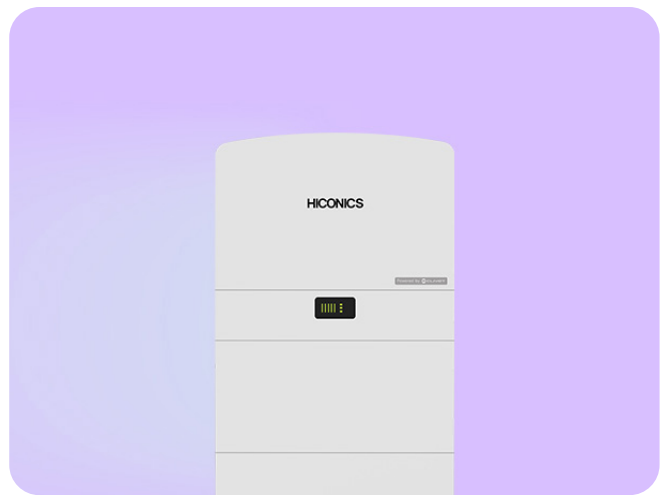

SINERGY2

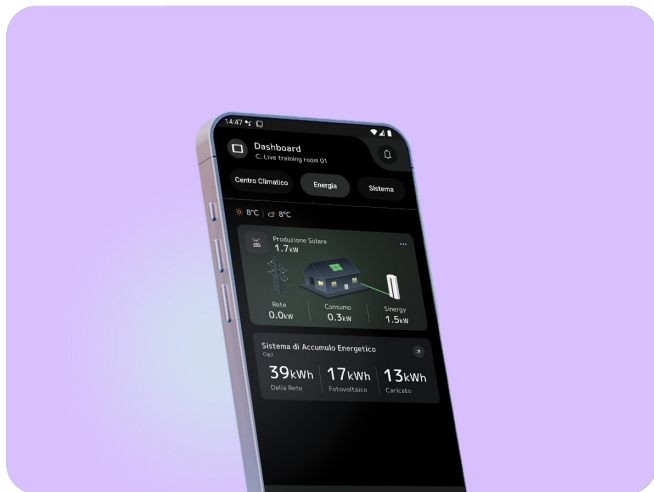

CLIVET EYE

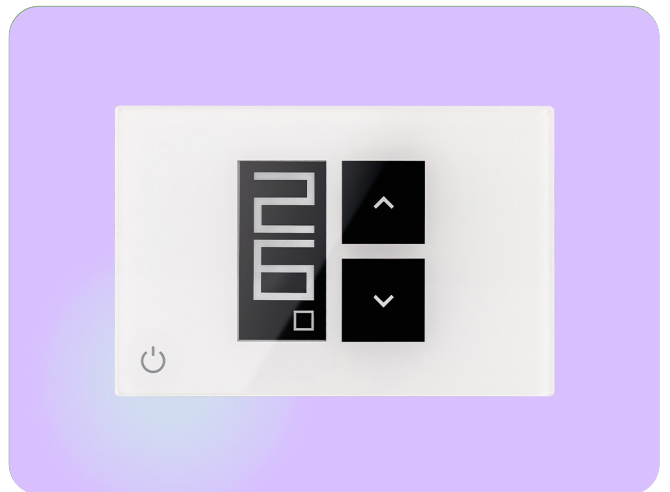

HID-T CONNECT2

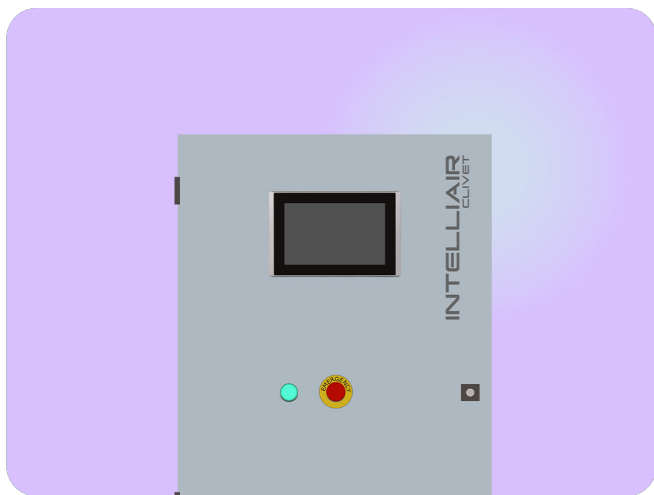

CENTRALISED SYSTEMS

CONTROL4 NRG

Comfort and energy assistant for Clivet Smart Living





Comfort

- 

Summer, winter and DHW management
- 

Humidity control
- 

Air quality renewal and monitoring
- 

ECO
- 

Differentiated temperatures per area
- 

Underfloor system, fancoils, radiators

Convenience

- 

Scheduling Weekly
- 

Away
- 

Weather forecast
- 

Voice control
- 

ON/OFF

Energy Optimisation

- 

Total system management dashboard
- 

Weekly energy produced/consumed dashboard
- 

Weekly energy accumulated dashboard
- 

Class A environmental control
- 

Heat pump set-point compensation
- 

Quick start-up
- 

Instantaneous energy

- ✓ Intelligent coordination of all Clivet devices such as heat pumps, fan coils, air renewal and air purification systems for optimal comfort;
- ✓ Dynamic energy management through Smart Living logics towards energy independence
- ✓ Simultaneous and independent comfort management of up to 24 climate areas
- ✓ Temperature management, humidity control, air quality monitoring;
- ✓ Comfort management from anywhere, always connected with the Clivet Eye App
- ✓ Integration with the KNX (Konnex) system provides area comfort control using KNX thermostats
- ✓ Simultaneous operation in system and DHW (Hybrid version)

Comfort becomes smart

CONTROL4 NRG is the energy and comfort assistant for your house that puts the Clivet Smart Living system at your fingertips. Specific features developed to make the electric house more intelligent and welcoming, optimise energy consumption and improve house comfort, customised to your needs.

Voice assistants

Voice assistants, or more commonly known as Voice Skills, improve accessibility for people with visual or motor disabilities, allowing access to the system (or equipment) without having to physically interact with the devices.

Thanks to Alex voice skills, developed specifically for Clivet, it is possible to interact with the Smart Living system not only to set the best level of ambient comfort and well-being, but also to be kept up-to-date on energy trends and the level of independence.



Clivet Smart Living

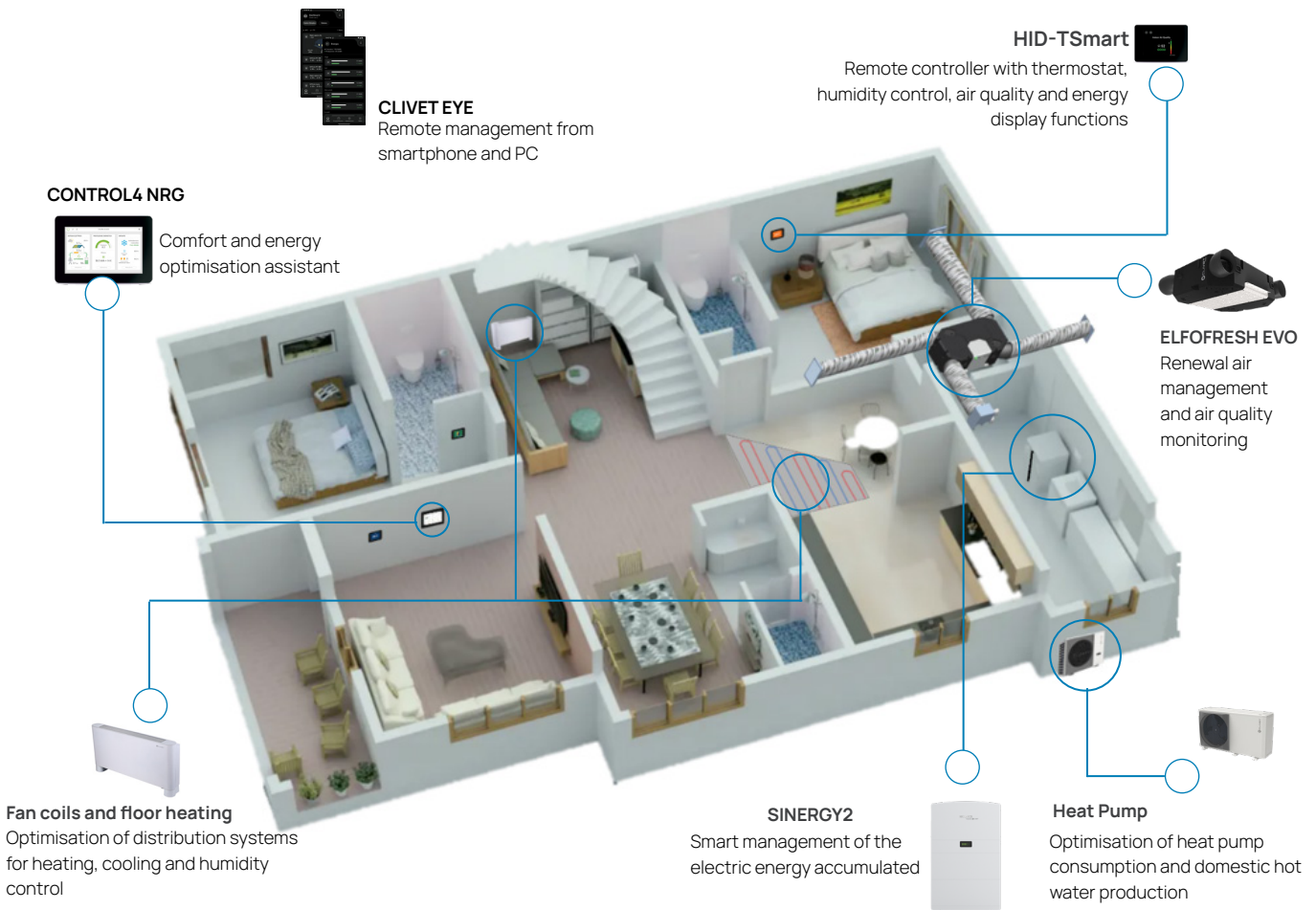

HID-TSmart

HID-TSmart is not only a smart thermostat, it is also an extension of CONTROL4 NRG that can provide information on the main system operating parameters simply and immediately: it allows you to acquire information on the temperature, relative humidity, energy consumption, energy produced by the photovoltaic system, charging level of the Clivet SINERGY electric water tank and, lastly, to set the desired temperature

It is enhanced with area control that allows you to set the system mode and ventilation level.

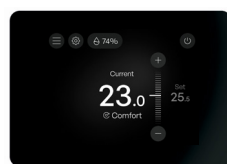
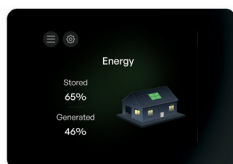
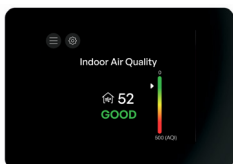

3,5" full touchscreen

Versions

S-W	Ethernet port, no Wi-Fi connectivity. White color
S-B	Ethernet port, no Wi-Fi connectivity. Black color
WIFI-W	Ethernet port and Wi-Fi connectivity. White
WIFI-B	Ethernet port and Wi-Fi connectivity. Black

Accessories

Home automation connection		DOMX	Device for connection with home automation systems	53 x 92 x 63 mm
Energy management		M1NRGX	Single-phase electricity meter with EIA-485 ModBUS serial	53 X 32 X 63 mm
		M3NRGX	Three-phase electricity meter with EIA-485 ModBUS serial	17,5 X 90 X 68,3 mm
Communication with the room thermostat for temperature and humidity control		HTSBWX	White HID-TSmart thermostat with temperature sensor	112 x 77 x 18 mm
		HTSBBX	Black HID-TSmart thermostat with temperature sensor	
		HTSPWX	White HID-TSmart thermostat with temperature and humidity sensor	110 x 70 x 28 mm
		HTSPBX	Black HID-TSmart thermostat with temperature and humidity sensor	
		Z-IAQX	Acquisition of temperature, humidity, noise, VOC carbon monoxide, carbon dioxide and methane values	22 x 45 x 50 mm
		HIDURX	Temperature and humidity probe - uncased installation.	
Management of radiant panels (heat and cool), radiators, fan coils, heated towel rails, Management of zone valve, circulation pump, remote start-up		HIDURMX	Temperature and humidity probe with RS-485 port for bus installation - uncased installation.	22 x 45 x 50 mm
		BMZR	Module for managing up to 6 control outputs for shut-off valves supplying radiant panels, radiators or heated towel rails. Generic input/output functions.	157 x 90 x 60 mm 9 DIN modules
		AL12X	Power output 12VCC 2A	85 x 90 x 65 mm 4 DIN modules
		CMRSX	Module to manage up to 1 HID thermostat and 1 control output, shut-off valves to feed radiant panels, radiators or heating furniture	105 x 90 x 60 mm 6 DIN modules
		EMRSX	Mixing unit control module for managing a section of the circuit at a different temperature to that of the main system.	105 x 90 x 60 mm 6 DIN modules
		FCM010X	Fan coil control module with 0..10V output.	105 x 90 x 60 mm 6 DIN modules

Technical data

CONTROL4 NRG			
Display dimensions	inches		7"
Display type			TFT color
Power supply voltage	Vdc		12
Capacity	VA		10
Protection rating			IP 20
Weight	kg		0,5
Dimensions	mm		190 x 130 x 56

SINERGY2

Preview

Electric storage system

Single-phase version

Inverter 3,68 / 5 / 6 kW
Capacity 5 / 10 / 15 / 20/ 30 kWh



- ✓ 3,68/5/6 kW single-phase 230Vac hybrid inverter
- ✓ Dual MPPT input photovoltaic system
- ✓ High-voltage 5 kWh battery for improved efficiency, 6,000 charge/discharge cycles
- ✓ Modular system with up to 6 storage tanks for capacities of 5/10/15/20/30 kWh
- ✓ Stackable modular design, no cables required.
- ✓ On-grid function and back-up output for connecting loads in the event of a power failure
- ✓ "Anti-islanding" protection system
- ✓ Extended operating range from -20 °C to +55 °C
- ✓ IP65 protection rating



- 1 3,68 / 5 / 6 kW hybrid inverter including 2 MPPT inputs totalling
- 2 Battery pack charge level indicator
- 3 BMS Control Module
- 4 5 kWh High-Voltage Battery Pack
- 5 5 kWh High-Voltage Battery Pack

Three-phase version

Inverter 8 / 10 / 12 / 15 kW
Capacity 8 / 10 / 12 / 15 kW



- ✓ 8/10/12/15 kW three-phase 400Vac hybrid inverter
- ✓ Dual MPPT input photovoltaic system
- ✓ High-voltage 5 kWh battery for improved efficiency, 6,000 charge/discharge cycles
- ✓ Modular system with up to 8 storage tanks for capacities of 10/15/20/30/40 kWh
- ✓ Stackable modular design, no cables required.
- ✓ On-grid function and back-up output for connecting loads in the event of a power failure
- ✓ "Anti-islanding" protection system
- ✓ Extended operating range from -20 °C to +55 °C
- ✓ IP65 protection rating

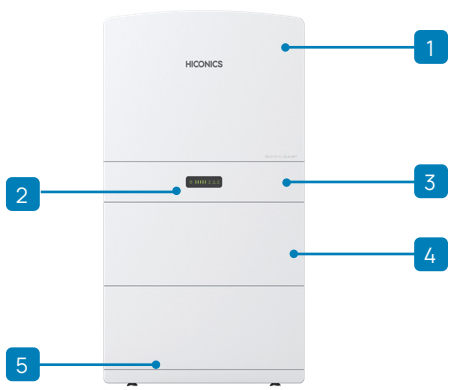

- 1 8/10/12/15 kW hybrid inverter including 2 MPPT inputs totalling
- 2 Battery pack charge level indicator
- 3 BMS Control Module
- 4 5 kWh High-Voltage Battery Pack
- 5 5 kWh High-Voltage Battery Pack

Operating mode

SELF-CONSUMPTION

The energy generated by the solar panels will be used in the following order:

1. to supply domestic loads
2. to charge the battery
3. Charging via grid again

When there is no sun, the battery will support the load to improve self-consumption.

If the power supply from the batteries is not enough, the grid will supply the load demand.

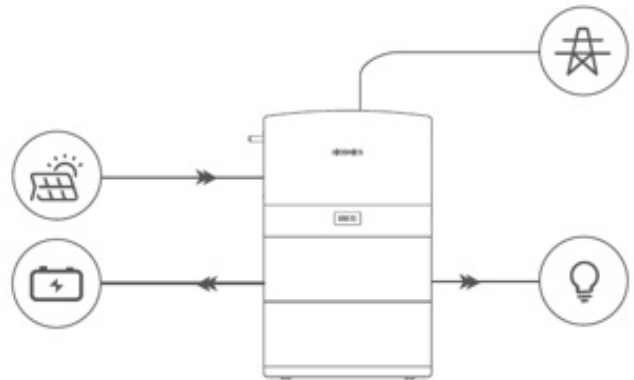

Self-consumption optimisation

The SINERGY2 water tank system is Clivet's solution for storing the electric energy produced by the photovoltaic system during daylight hours and using it to power the air conditioning and domestic hot water production system during the night or in the event of a grid energy failure. Combined with the CONTROL4 NRG energy assistant, the SINERGY2 range of electric accumulators ensures maximum self-consumption and energy independence in the house.

SINERGY2 is suitable for both new and existing installations. Thanks to the high degree of protection and operating range, SINERGY2 can be installed outdoors.

The special construction technology of the lithium iron-phosphate cell batteries provides a system life of up to 6000 charging and discharging cycles.

BACKUP

In this mode, the battery is only used as a backup power supply when the grid fails (off-grid)

when the grid fails, and as long as the grid works, the batteries will not be used to supply the loads (Batteries are always in charging/maintenance mode).

The battery will be charged with the energy generated by the photovoltaic system or by the grid.

On-site battery "charging" system.

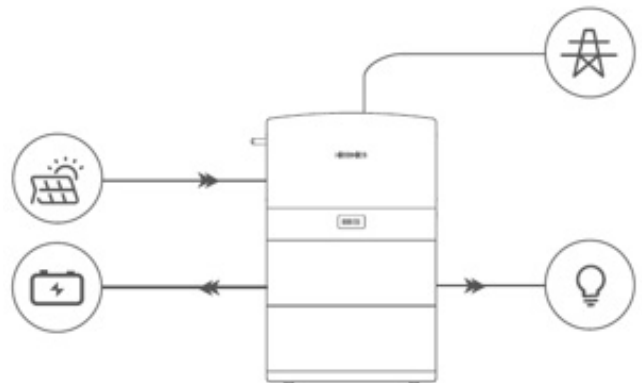

RECHARGING USING A TIME SLOT

This mode is used to activate the timed charge and discharge functions.

Used to charge the battery from the grid in the absence of a photovoltaic system.

Two (2) charge and discharge time slots (adjacent)

time slot 1 – charge and discharge

time slot 2 – charge and discharge

Example:

fascia 1 – 8.00..12.00 (charge) and 12.00..16.00 (discharge)

fascia 2 – 16.00..24.00 (charge) and 00.00..8.00 (discharge)

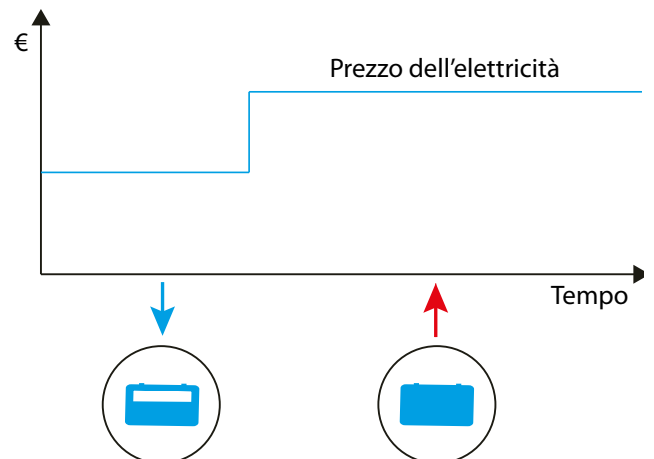

Existing system

Connection to an existing system is made without replacing existing inverters and photovoltaic panels.

The SINERGY2 system automatically stores the energy produced by the panels when it is not used by users connected to the grid. The photovoltaic inverter inputs are not used in this case

Installation is direct to the home network without additional wiring and/or connections.

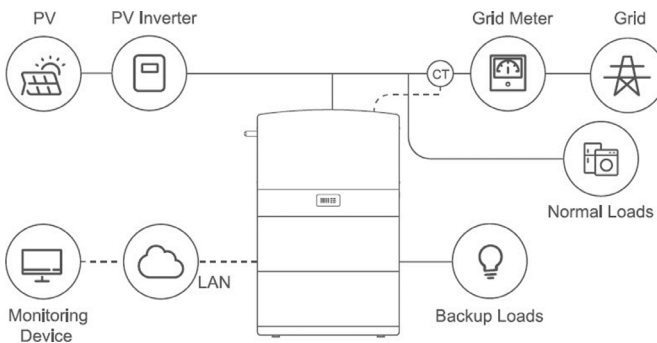

New system

In new installations, the photovoltaic system strings can be connected directly to the two direct current inputs in Clivet's SINERGY2 inverter.

The inverter has 2 MPPT inputs for connecting photovoltaic panels.

This configuration keeps the photovoltaic inverter costs low.

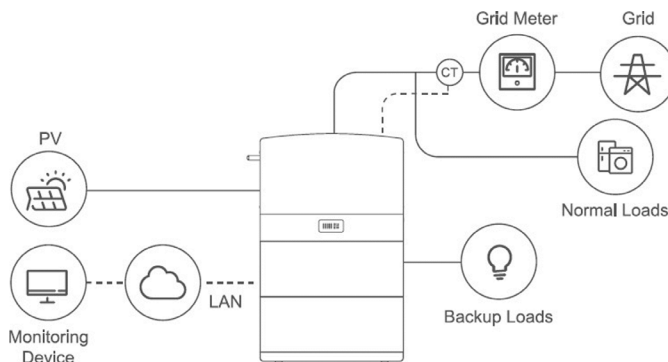

Complete installation

SINERGY2 makes it possible to extend the photovoltaic range and have more installed power.

In this type of installation, the new photovoltaic system can be installed without changing the existing system.

The inverter has 2 MPPT inputs for connecting photovoltaic panels.

Newly installed panels can be connected directly to the two direct current inputs in Clivet's SINERGY2 inverter.

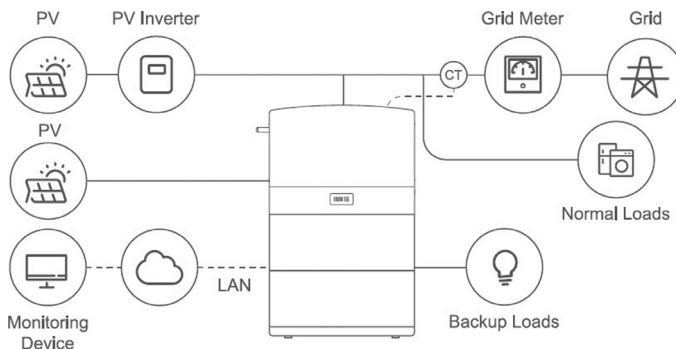

Characteristics of single-phase systems

HEC2-BHPxxr2 Range	HEC2-BHP50r2	HEC2-BHP100r2	HEC2-BHP150r2	HEC2-BHP200r2-A	HEC2-BHP300r2-A
Component	Base+BMS+1*Module	Base+BMS+2*Module	Base+BMS+3*Module	2*(Base+BMS+2*Module)	2*(Base+BMS+3*Module)
Nominal Voltage[V]	102.4	204.8	307.2	204.8	307.2
Maximum protection voltage[V]	116.8	233.6	350.4	233.6	350.4
Minimum protection voltage[V]	89.6	179.2	268.8	179.2	268.8
Battery module	Modulo*1	Modulo*2	Modulo*3	Modulo*4	Modulo*6
Nominal capacity[Ah]	50	50	50	100	100
Total energy[kWh]	5.1	10.2	15.3	20.4	30.6
Nominal power [kW]	2.56	5.12	7.68	10.24	15.36
Nominal charge/discharge current[A]		25			50
Max. charge/discharge current[A]		25			50
Cycle life	6000 Cicli(@0.5C,90%DOD,25°C,60%SOH)				
Expected life time	10 anni(60%SOH)				
Operating Temperature (°C)	-20 to 55 (derating above 45°C)				
Storage temperature[°C]	Da -20°C a 55°C (1 mese); da -20°C a 45°C (3 mesi); da -20°C a 35°C (1 anno)				
Altitude[m]	Sotto i 2000 m				
Protection	IP65				
System to Inverter	RS485/CAN2.0				
Battery to battery / BMS	Daisy chain				
Display Interface	LED				
Switch on/off		Button*1+Breaker*1			2*(Button*1+Breaker*1)
Weight [kg]	69±4	124±6	179±8	248±12	358±16
External dimensions(W*H*D) (mm)	(800±20) * (530±30) * (160±20)	(800±20) * (840±30) * (160±20)	(800±20) * (1150±30) * (160±20)	(1600±20) x (840±30) x (160±20)	(1600±20) x (1150±30) x (160±20)
Remark		Serie 1			2 serie parallele

Characteristics of three-phase systems

HEC2-BHPxxr2-EU Series	HEC2-BHP100r2-EU	HEC2-BHP150r2-EU	HEC2-BHP200r2-EU	HEC2-BHP200r2-A-EU	HEC2-BHP300r2-A-EU	HEC2-BHP400r2-A-EU
Component	Base+BMS+2*Module	Base+BMS+3*Module	Base+BMS+4*Module	2*(Base+BMS+2*Module)	2*(Base+BMS+3*Module)	2*(Base+BMS+4*Module)
Nominal Voltage[V]	204.8	307.2	409.6	204.8	307.2	409.6
Maximum protection voltage[V]	233.6	350.4	467.2	233.6	350.4	467.2
Minimum protection voltage[V]	179.2	268.8	358.4	179.2	268.8	358.4
Battery module	Modulo*2	Modulo*3	Modulo*4	Modulo*4	Modulo*6	Module*8
Nominal capacity[Ah]	50	50	50	100	100	100
Total energy[kWh]	10.2	15.3	20.4	20.4	30.6	40.8
Nominal power [kW]	5.12	7.68	10.24	10.24	15.36	20.48
Nominal charge/discharge current[A]		25			50	
Max. charge/discharge current[A]		30			50	
Cycle life	6000 Cicli(@0.5C, 90%DOD, 25°C, 60%SOH)					
Expected life time	10 anni (60% SOH)					
Operating Temperature (°C)	-20 to 55 (derating above 45°C)					
Storage temperature[°C]	Da -20°C a 55°C (1 mese); da -20°C a 45°C (3 mesi); da -20°C a 35°C (1 anno)					
Altitude[m]	Sotto i 2000 m					
Protection	IP65					
System to Inverter	RS485/CAN2.0					
Battery to battery / BMS	Daisy chain					
Display Interface	LED					
Switch on/off	Button*1+Breaker*1			2*(Button*1+Breaker*1)		
Weight [kg]	124±6	179±8	234±10	248±12	358±16	468±20
External dimensions(W*H*D) (mm)	(800±20) x (840±30) x (160±20)	(800±20) x (1150±30) x (160±20)	(800±20) x (1460±30) x (160±20)	(1600±20) x (840±30) x (160±20)	(1600±20) x (1150±30) x (160±20)	(1600±20) x (1460±30) x (160±20)
Remark	Serie 1			2 serie parallele		

Single-phase inverter characteristics

	HEC2-S3.68Hr2	HEC2-S5.0Hr2	HEC2-S6.0Hr2
PV Input			
Max. PV array power [W]		3750/3750	
Maximum DC voltage [V]		600*3	
Nominal DC operating voltage [V]		360	
MPPT voltage range [V]		100-540	
MPP voltage range for nominal power [V]*5	137-480	185-480	225-480
Start up voltage [V]		120	
Max. input current (A/B) [A]		15/15	
Max. short circuit current (A/B) [A]		18/18	
No. of MPP tracks/String per MPP tracker		2/1	
BAT Side			
Battery voltage range [V]		85*4-400	
Battery voltage range for nominal power [V]	160-400	225-400	250-400
Recommended battery voltage [V]		300	
Max. charge/discharge current [A]*2		25/25	
Communication interfaces		RS485/CAN	
AC Grid Side (On-grid)			
Reverse connect protection		Si	
Nominal AC output power [W]	3680	5 ⁹⁰⁰ *1	6 ⁹⁰⁰ *1
Maximum output power (W)	3680	5000*1	6 ⁹⁰⁰ *1
Nominal AC output apparent power to grid (VA)	3680	5000*1	6 ⁹⁰⁰ *1
Max. AC apparent power from grid (VA)	3680	5000*1	6 ⁹⁰⁰ *1
Nominal AC apparent power from grid (VA)	3680	5000*1	6 ⁹⁰⁰ *1
Max. AC apparent power from grid (VA)	6 ⁹⁰⁰ *6	6 ⁹⁰⁰ *6	6000
Nominal grid voltage [V]		L/N/PE 230Vc.a	
Grid voltage range [V]		180-280	
Nominal grid frequency [Hz]		50	
AC grid frequency range (Hz)		50±5	
Max. AC output current to grid [A]	16A a.c	21.7A a.c	26.1A a.c
Rated AC output current to grid [A]	16A a.c	21.7A a.c	26.1A a.c
Nominal AC current from grid (A)	16A a.c	21.7A a.c	26.1A a.c
Max. AC current from grid (A)	26.1*6A a.c	2 ⁹⁰⁰ *6A a.c	26.1A a.c
Power factor	~1 (regolabile da 0.8 leading a 0.8 lagging)		
1.THD [%]	< 3@Potenza nominale	< 5@Potenza nominale	
EPS side			
Nominal backup apparent power (VA)	3680	5000	6000
Nominal power [W]	3680	5000	6000
Max. output apparent power (off-grid) (VA)		7500@10sec	
Max. output apparent power (on-grid) (VA)		7500@10sec	
Nominal output voltage [V]		L/N/PE 230Vc.a	
Nominal output frequency [Hz]		50	
Nominal output current (A)	16	21.7	26.1
Max output current [A]	16	21.7	26.1
Max. output overcurrent protection [A]		32.6@10sec	
Max. output overcurrent protection [A] Switch time from off-grid to on-grid mode [ms]		< 20	
Output THD [%]		< 5% @ Linear load	

Efficiency			
MPPT efficiency[%]		99.0	
Euro efficiency[%]	95.0	95.2	95.2
Max. efficiency[%]	96.5	96.7	96.8
Battery charge/discharge efficiency[%]	97.6 (PV-BAT) 95.4 (BAT-AC)	97.6 (PV-BAT) 96.0 (BAT-AC)	97.6 (PV-BAT) 96.0 (BAT-AC)
Environment Limit			
Ingress protection		IP65	
Protection class		Class III	
Pollution degree		PD3	
Overvoltage category		III (MAIN GRID), II (DC)	
Operating temperature range [°C]		-20~+60 (derating at +45)	
Max. operation altitude [m]		< 2000	
Humidity		0-95%	
Cooling method		Convezione naturale	
User interface		LED, APP	
Communication with BMS		CAN/485	
Communication with Meter		485	
Communication with Portal		WIFI	
Typical noise emission [dB]		< 40	
Dimension (W*H*D) [mm]		800*450*160	
Weight [KG]		34	
Topology		Non-isolated	
Self-consumption at Night (W)		< 25	
DC Connector		MC4 (4~6mm ²)	
AC Connector		Spina rapida	
Safety		10	
Standard			
Safety		IEC/EN 62109-1&2, IEC62477	
EMC		IEC61000-6-1, IEC61000-6-3	
Environment		IEC60529, IEC60068	
Efficiency		IEC61683	
Certification		EN50549-1, G99, G98, CEI021, VDE4105, AS4777.2, NRS-097	

*1: The grid feed in power for VDE4105 is limited 4600VA.

*2: Battery charging current is limited 25A and power is limited 6000W.

*3: The machine may be damaged if PV port exceeds this voltage, full power operation voltage should be less than 480V, 480V-540V for limited power operation.

*4: Battery port boot voltage must be greater than 95V.

*5: The power is 6000W according to the grid port.

*6: The value will appear when the grid is charging battery and support EPS load.

Three-phase inverter characteristics

	HEC2-T8.0Hr2-Eu	HEC2-T10.0Hr2-Eu	HEC2-T12.0Hr2-Eu	HEC2-T15.0Hr2-Eu
PV Input				
Max. PV array power[W]	(4250+4250)/5000	(5250+5250)/6000	(5500+5500)/7000	(7000+7000)/8500
Max. open circuit voltage[V]		1000		
Max. input current(A/B)[A]		26/16		
Max. short circuit current(A/B)[A]		30/20		
Mppt voltage range[V]		180-950		
Mppt voltage range at full load[V]	327-850	404-850	423-850	540-850
Start operating voltage[V]		200		
No. of MPP tracks/String per MPP tracker(A/B)		2/(2/1)		
BAT Input				
Battery voltage range[V]		180-650		
Nominal charge/discharge current[A]		30/30		
Communication interfaces		RS485/CAN		
Reverse connect protection		SI		
AC Grid Input				
Nominal AC input power[VA]	16000	20000	20000	20000
Max. AC input power[W]	16000	20000	20000	20000
Nominal AC current[A]	26	32	32	32
Max AC current[A]	22.2/23.2/24.3	27.8/29/30.3	27.8/29/30.3	27.8/29/30.3
Nominal Apparent Power from Utility Grid (VA)	16000	20000	20000	20000
Max. Apparent Power from Utility Grid (VA)	16000	20000	20000	20000
Nominal grid voltage[V]		415/240~; 400/230~; 380/220V~; 3L/N/PE		
Nominal grid frequency[Hz]		50/60		
AC grid output				
Nominal AC output power[W]	8000	10000	12000	15000
Max. AC output power[W]	8800	11000	13200	15000
Max apparent power to Utility Grid [VA]	8800	11000	13200	15000
Nominal grid voltage[V]		415/240~; 400/230~; 380/220V~; 3L/N/PE		
Nominal grid frequency[Hz]		50/60		
Max output AC current[A]	13.3	16.7	20	24
Nominal output AC current[A]	11.6@230VAC	14.5@230VAC	17.4@230VAC	21.7@230VAC
Displacement power factor		-0.8~0.8		
THDi [%]		< 3@Rated power		
AC Grid Output				
Nominal EPS output power[W]	8000	10000	12000	15000
Max. EPS output apparent power[VA]	8000	10000	12000	15000
Nominal voltage[V]■frequency[Hz]		230/400, 50/60		
Max output current[A]	12.9	16.1	19.3	24
Nominal output current[A]	11.6	14.5	17.4	21.7
Inrush peak Current(A)	65	65	65	65
Switching from grid-connected mode to standalone mode [ms]		< 20		
Switching from standalone mode to grid-connected mode [ms]		> 60s @VDE-AR-N 41052018-1		
THDv [%]		< 3@Linear Load		

Efficiency	
MPPT efficiency[%]	99.9
Euro efficiency[%]	96.1
Max. efficiency[%]	97.7
Battery charge/discharge efficiency[%]	98.5(PV-BAT) , 97(BAT-AC)
Environment Limit	
Ingress protection	IP65
Protection class	Class I
Pollution degree	PD3(esterno)PD2(interno)
Overvoltage category	Grid overvoltage category III / PV & Battery overvoltage category II
Operating temperature range [°C]	-20~+60(derating at +45)
Max.operation altitude[m]	3000
Humidity	0-95%
Storage temperature[°C]	-40~70
Typical noise emission[dB]	< 45
Communication with BMS	CAN/RS485
Communication with Meter	RS485
Communication with Portal	RS485
Dimension and weight	
Dimension(W*H*D)[mm]	800(±2)x525(±2)x160(±2)
Weight [KG]	52(±5)
Cooling concept	Smart cooling
Topology	Non-isolato
Communication interfaces	Misuratore/CT, CAN, RS485, WIFI(Esterno)
HMI	APP
DC Connector (mm ²)	4-6
AC Connector (mm ²)	6-10
Certification	EN50549-1/EN50549-10, IEC/EN62040-1, IEC/EN 61000-6-1/2/3/4, VDE-AR-N 4105, CEI 0-21, G98/G99, PTPIREE ,2021-04; NC RFG; PSE, UNE 217002:2020, UNE 217001:2020, NTS 2019 V2.1, G100, TOR Erzeuger TipoA V1.2, AS/NZS4777.2:2020+A1, NRS 097-2-1:2017

CLIVET EYE

Smart Living remote monitoring and management system



- ✓ App and PC control of all elements connected to Clivet Smart Living
- ✓ Display of system energy data
- ✓ Display of any malfunctions of individual air conditioning control system elements
- ✓ Accessible from App and web browser via PC
- ✓ App available on Android and iOS platforms

General characteristics

Clivet Eye is the IoT platform for interconnecting all Clivet solutions securely and reliably with end users and residential professionals . Clivet Eye allows users to take advantage of all the services related to remote access and optimisation of air conditioning systems. The most relevant information of the Smart Living system such as Sinergy, for electricity storage and heat pump units can be easily consulted through a modern interface.

Smart Living from a single App

Clivet Eye combines management of all the elements that make up the Clivet Smart Living and the energy produced and consumed by the house in a single App. Management via the App is possible through connection with the Control4 NRG energy and comfort assistant, which combines all system parameters and optimises operation of the entire system.

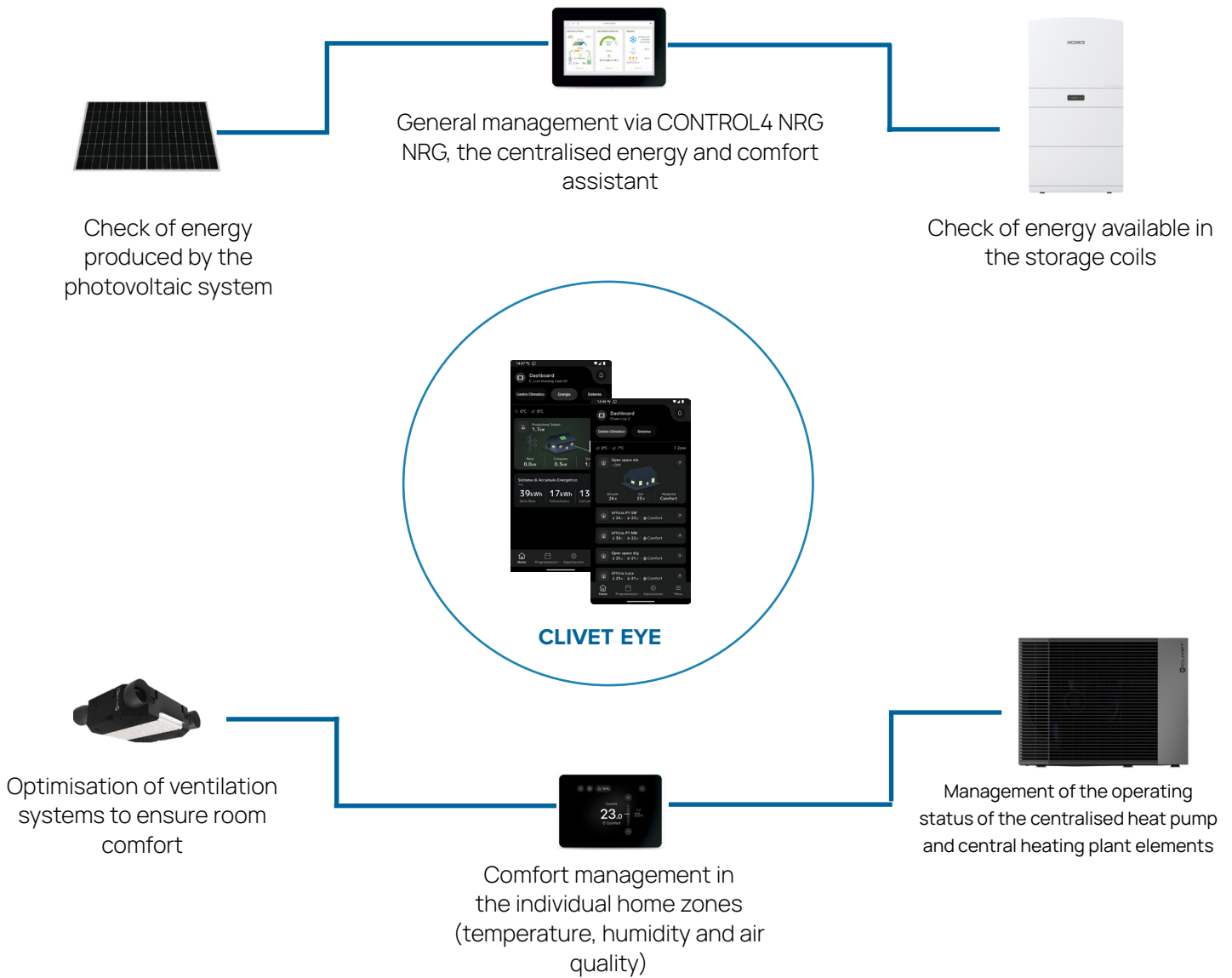

Smart Living from a single App

Home page

Display of the status of all devices connected to CONTROL4 NRG.

Energy dashboard shows:

- Photovoltaic system with real time power output value
- Energy consumed by the building
- Charge and discharge levels of the Sinergy storage system

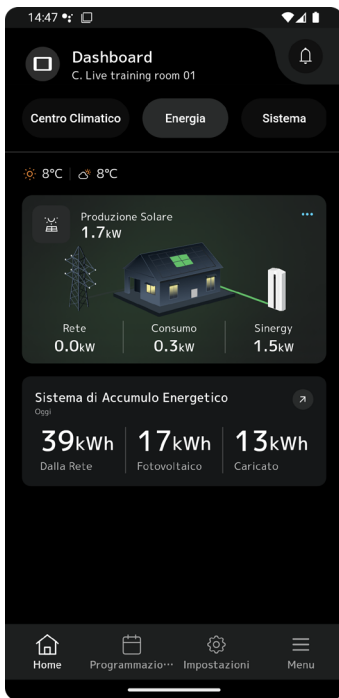

New “Climate Centre”

For each of the 24 independent climate areas, the relevant setpoint can be set so as to always obtain the ideal comfort levels.

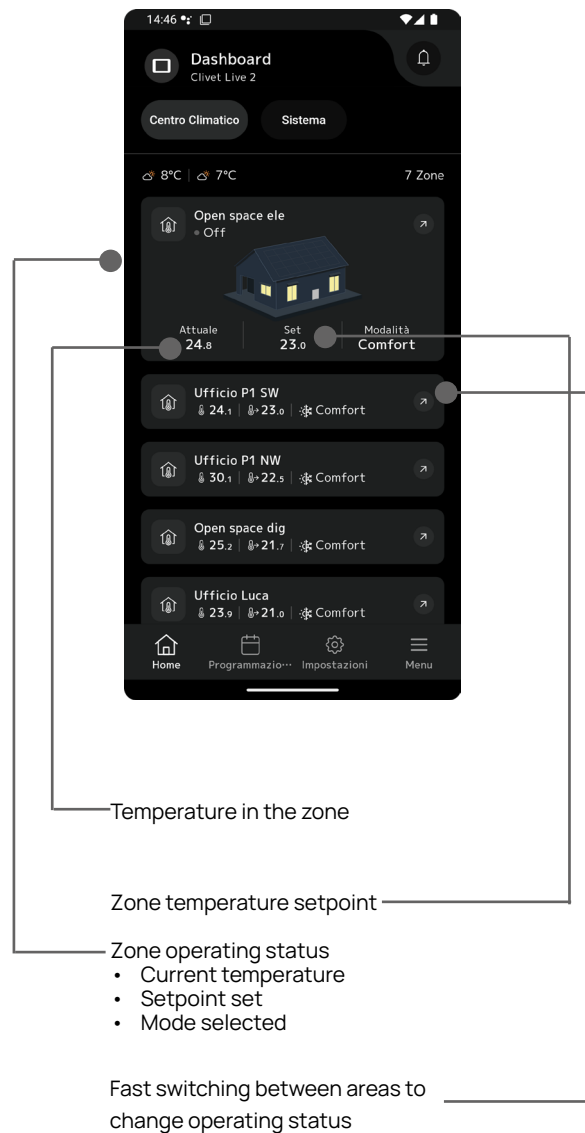

The screens shown are for demonstration purposes only.

The whole system

Scheduler

Allows the comfort scheduling of each independent zone to be managed from the app

Energy page

Designed to display the energy data of the last 7 days.

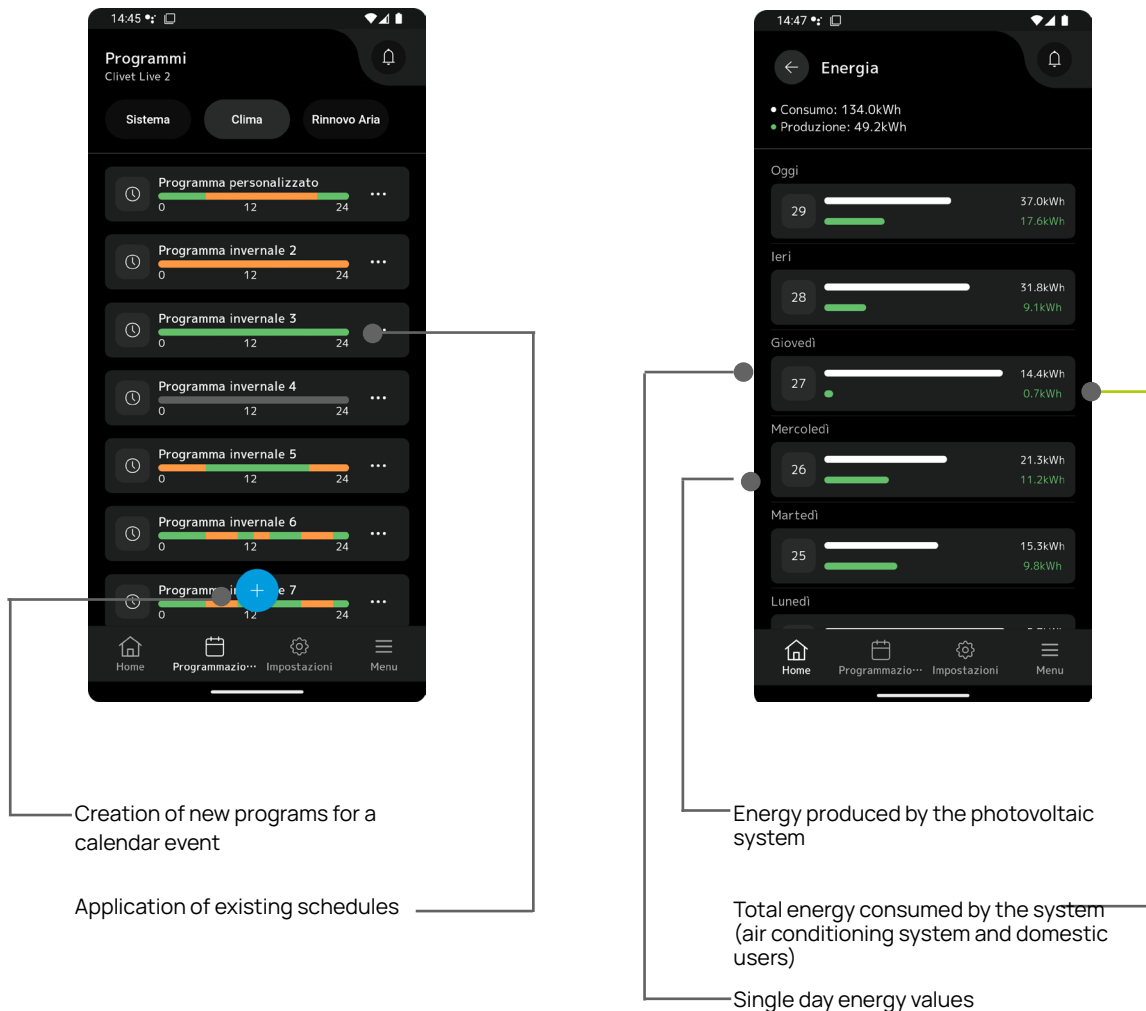

The screens shown are for demonstration purposes only.

HID-TConnect2

Chronothermostat with temperature control and management via App /Voice contro

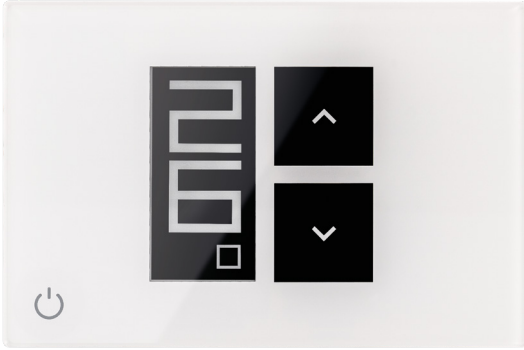

- ✓ Touch-screen management via a thermostat, via App from your smartphone, via Alexa / Google Home with voice-activated control
- ✓ Manages the mode change or call in two areas (with the SwitchConnect accessory)
- ✓ Can be connected via Wi-Fi to create a wireless system (with the SwitchConnect accessory)
- ✓ Option of setting a limitable setpoint for installation in B&Bs or hotel rooms

Management via App

HID-TConnect2 is managed as standard supplied with the dedicated Clivet Home Connect App, available on Google Play and App Store. This is used to set the main functions, such as changing the ambient set-point or weekly scheduling, or to check the temperature and consumption log.

Cabled connection to the generator

HID-TConnect2 can be wired directly to the heat pump without additional accessories: ideal to manage a heat-only radiator system.

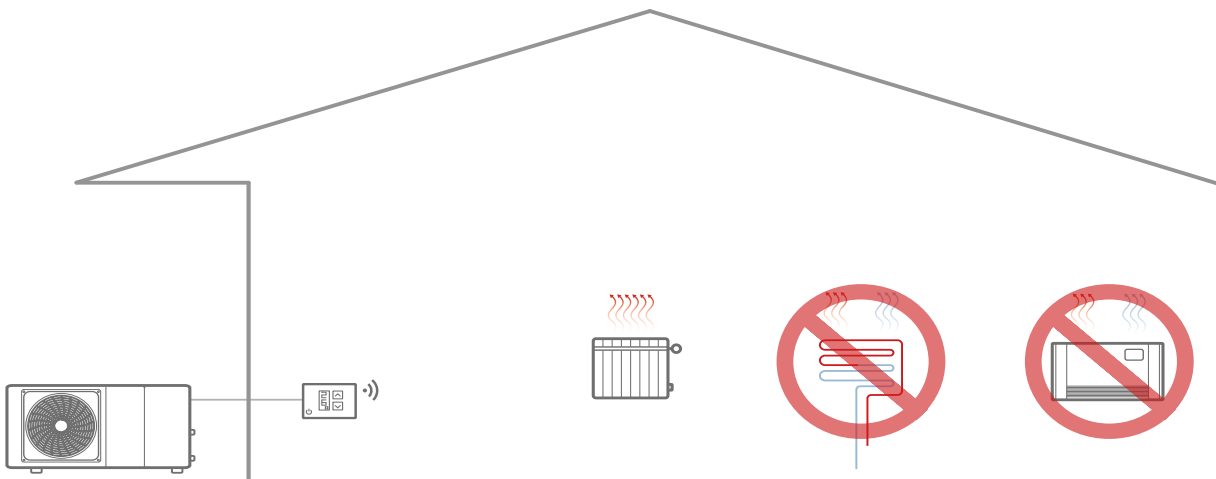

Note: mode change and distribution system management not available

Cabled connection to the generator and Wi-Fi distribution connection

HID-TConnect2 can be wired to the heat pump and communicate via Wi-Fi with up to 2 Connect Switches. Each of these accessories is equipped with a relay that can manage the opening/closing of the heads of a radiant system or the remote ON/OFF of a fan coil unit.

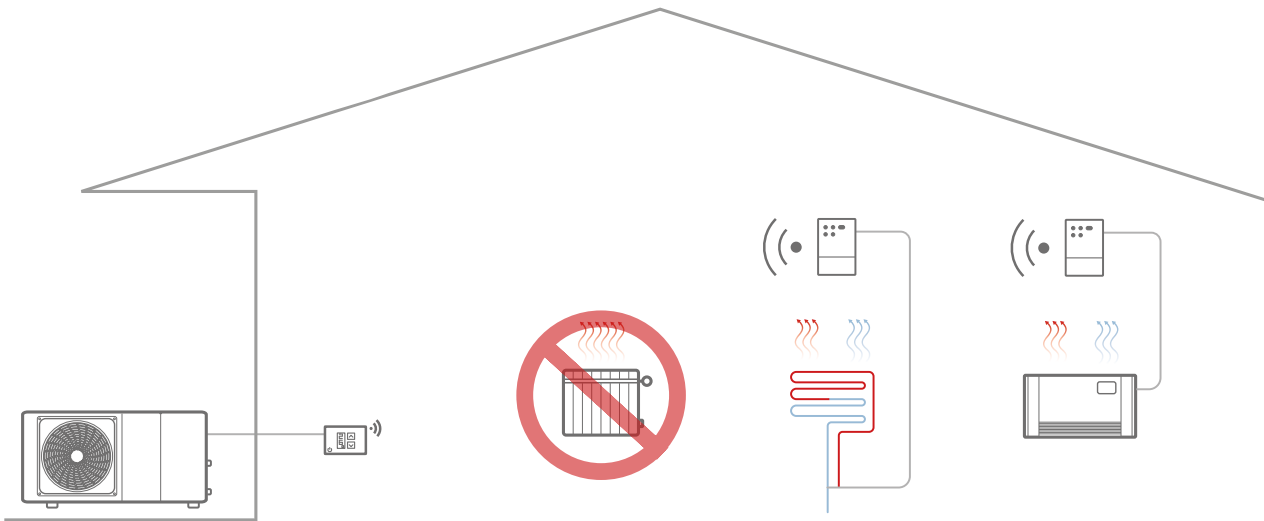

Note: the mode change must be managed in the heat pump (from the user interface or the MSmart Home App).

Wi-Fi connection to the generator and cabled distribution connection

HID-TConnect2 can be connected via cable and open/close the heads of a radiant system or remotely turn a fan coil ON/OFF. The signal of a single thermostat can manage several fan coils or radiant panels.

The request to the heat pump is made via Wi-Fi through SwitchConnect, which thanks to the double relay changes the generator mode (can only be managed via the App).

Each SwitchConnect can support up to 6 thermostats.

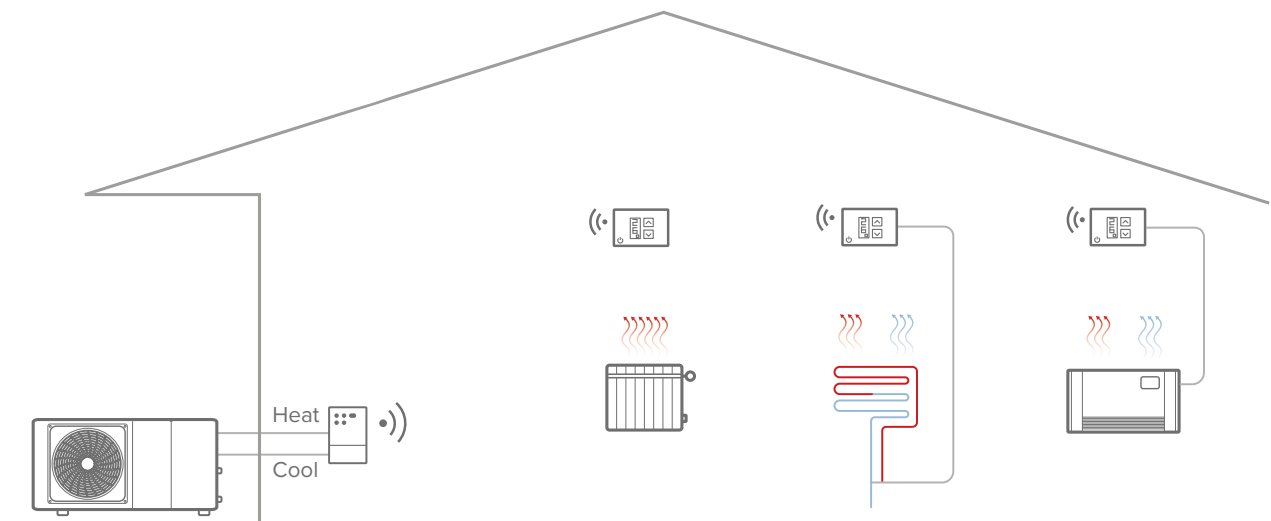

Note: in the event of conflicting heating / cooling requests, priority is given to cooling.

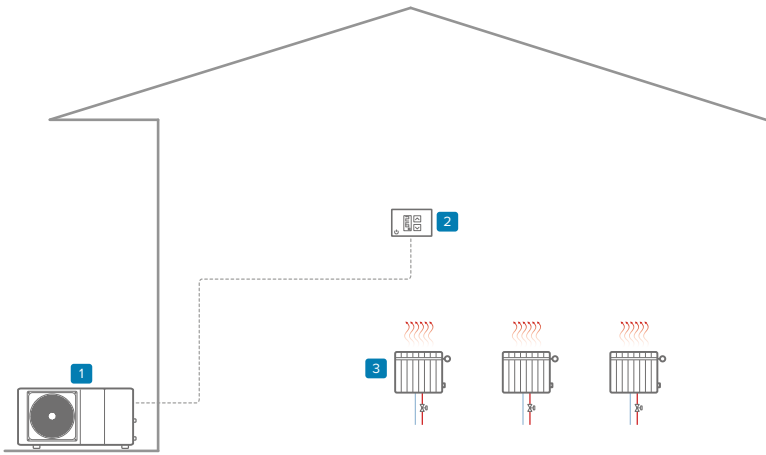

Single-area system, radiators, cabled connection to the generator

- 1 Outdoor unit
- 2 HID-TConnect2
- 3 Radiators

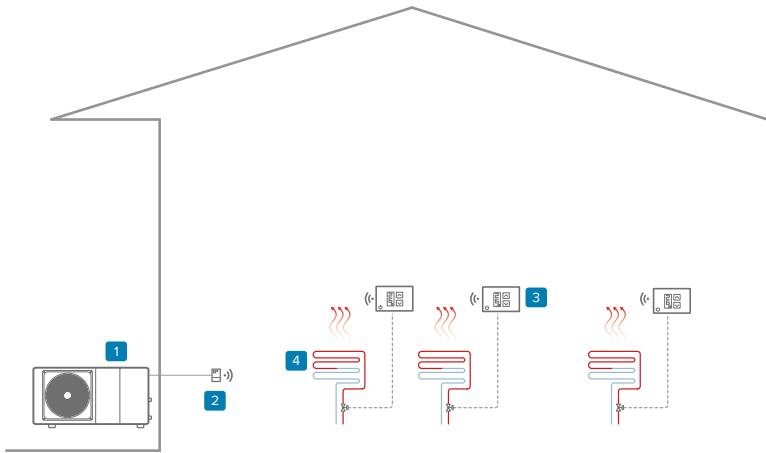

Heat-only single-area system, radiant / terminal units, Wi-Fi connection to the generator and cabled distribution connection

- 1 Outdoor unit
- 2 SwitchConnect
- 3 HID-TConnect2
- 4 Radiant floor

Note: can support up to 6 thermostats

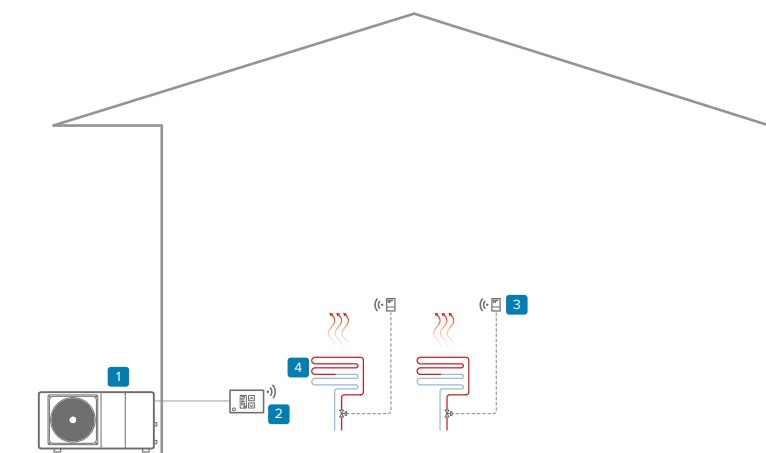

Heat-only single-area system, radiant / terminal units, cabled connection to the generator and Wi-Fi distribution connection

- 1 Outdoor unit
- 2 HID-TConnect2
- 3 SwitchConnect
- 4 Radiant floor

Note: can support up to 2 SwitchConnect

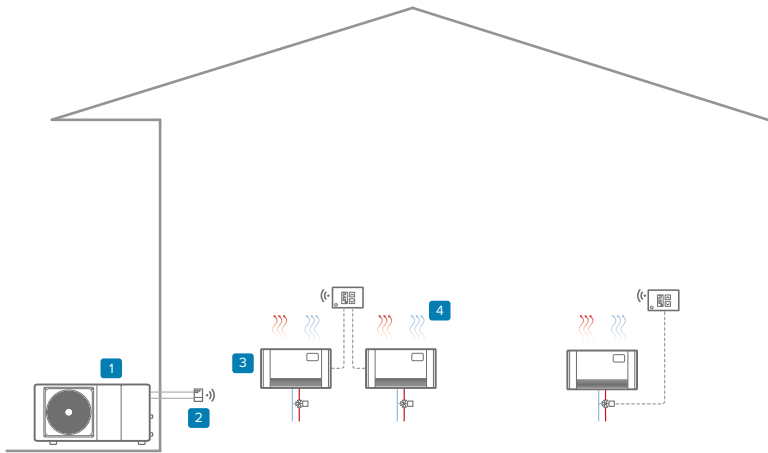

Heating/cooling single area system, radiant / terminal units, Wi-Fi connection to the generator and cabled distribution connection

- 1 Outdoor unit
- 2 SwitchConnect
- 3 Fan-coils
- 4 HID-TConnect2

Note: can support up to 6 thermostats.
The thermostats must all be in heating or cooling mode.
In the event of conflicting requests, priority is given to cooling

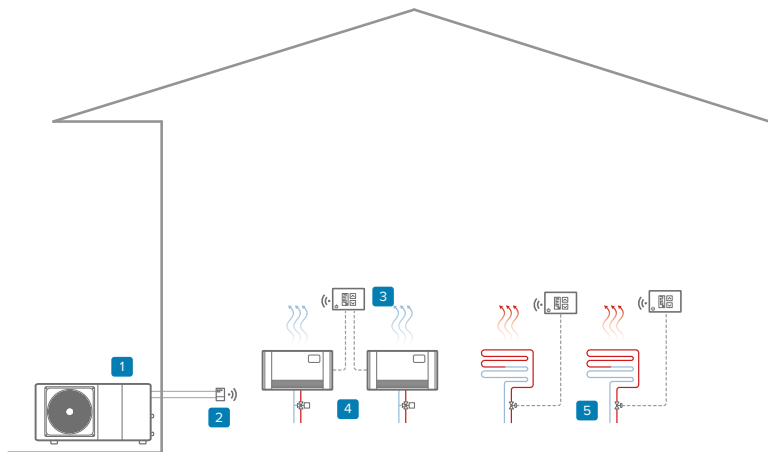

Dual emitter system, radiant / terminal units, Wi-Fi connection to the generator and cabled distribution connection

- 1 Outdoor unit
- 2 SwitchConnect
- 3 HID-TConnect2
- 4 Fan-coils
- 5 Radiant floor

Note: can support up to 6 thermostats.
The mode must be changed directly on the unit.
The thermostats must all be in heating or cooling mode. In the event of conflicting requests, priority is given to cooling

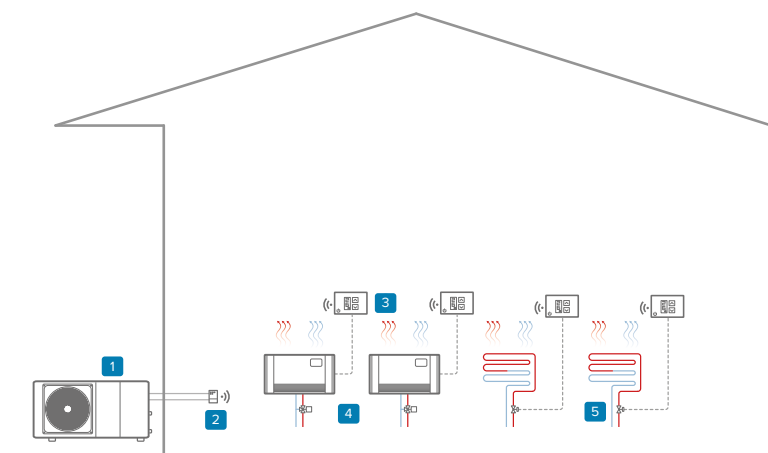

Heating/cooling dual area system, radiant / terminal units, Wi-Fi connection to the generator and cabled distribution connection

- 1 Outdoor unit
- 2 SwitchConnect
- 3 HID-TConnect2
- 4 Fan-coils
- 5 Radiant floor

Note: can support up to 6 thermostats.
The mode must be changed directly on the unit.
The thermostats must all be in heating or cooling mode. In the event of conflicting requests, priority is given to cooling

INTELLIPLANT

Management and optimisation system for centralised residential systems



- ✓ Control and optimisation of heat pumps in centralised systems
- ✓ Backup boiler management
- ✓ Central heating plant and individual user consumption metering
- ✓ Housing unit management with CONTROL4 NRG
- ✓ Local and remote management by administrators via cloud connection
- ✓ Multi-site platform for the remote management of different systems located across the country

Safety and professionalism

The INTELLIPLANT system separates the management of centralised systems by professionals from the management of residential environments by private users via two separate cloud platforms.

This allows condominium administrators and personnel to access the central heating plant without being given access to individual homes, while maintaining data protection privacy levels in accordance with the most stringent provisions of the GDPR (Global Data Protection Regulation).

At the same time, the owners and tenants of the various housing units can manage their own flat but not the centralised system, thus avoiding tampering or management problems of professional systems.

System managers

The INTELLIPLANT system allows you to efficiently and continuously manage the system on the local operator panel and the remote interface on a computer, smartphone or tablet.

- ✓ Secure management by connection to the Clivet cloud for professional environments
- ✓ Management of operating parameters such as temperature and seasonal mode change
- ✓ Scheduled and manual system switch-on
- ✓ Wear check of the main components
- ✓ Management of scheduled and preventive maintenance
- ✓ Online management of system documentation
- ✓ Lower maintenance costs, prevention of system downtime due to faults
- ✓ Management of thermal energy produced by the central heating plant and electricity consumption
- ✓ Calculation of system efficiency
- ✓ Consumption metering via connection to the CONTROL4 NRG energy assistants of the housing units

Private users

Each housing unit is managed by the CONTROL4 NRG energy assistant, which optimises room comfort while reducing energy consumption.

- ✓ Safe management by connection to CLIVET EYE for private-use residential environments
- ✓ Remote system management via the App for iOS and Android devices
- ✓ Separate management of zones and their comfort levels
- ✓ Compatibility with HID-TSmart thermostats to display the home operating parameters such as temperature, humidity, electricity consumption, air quality, SINERGY2 coil charge level (when present)
- ✓ Consumption metering via connection to the CONTROL4 NRG energy assistants of the housing units

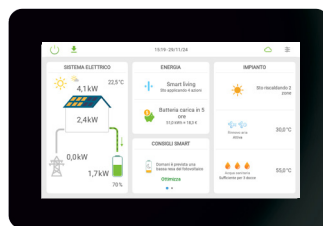

Example of infrastructure

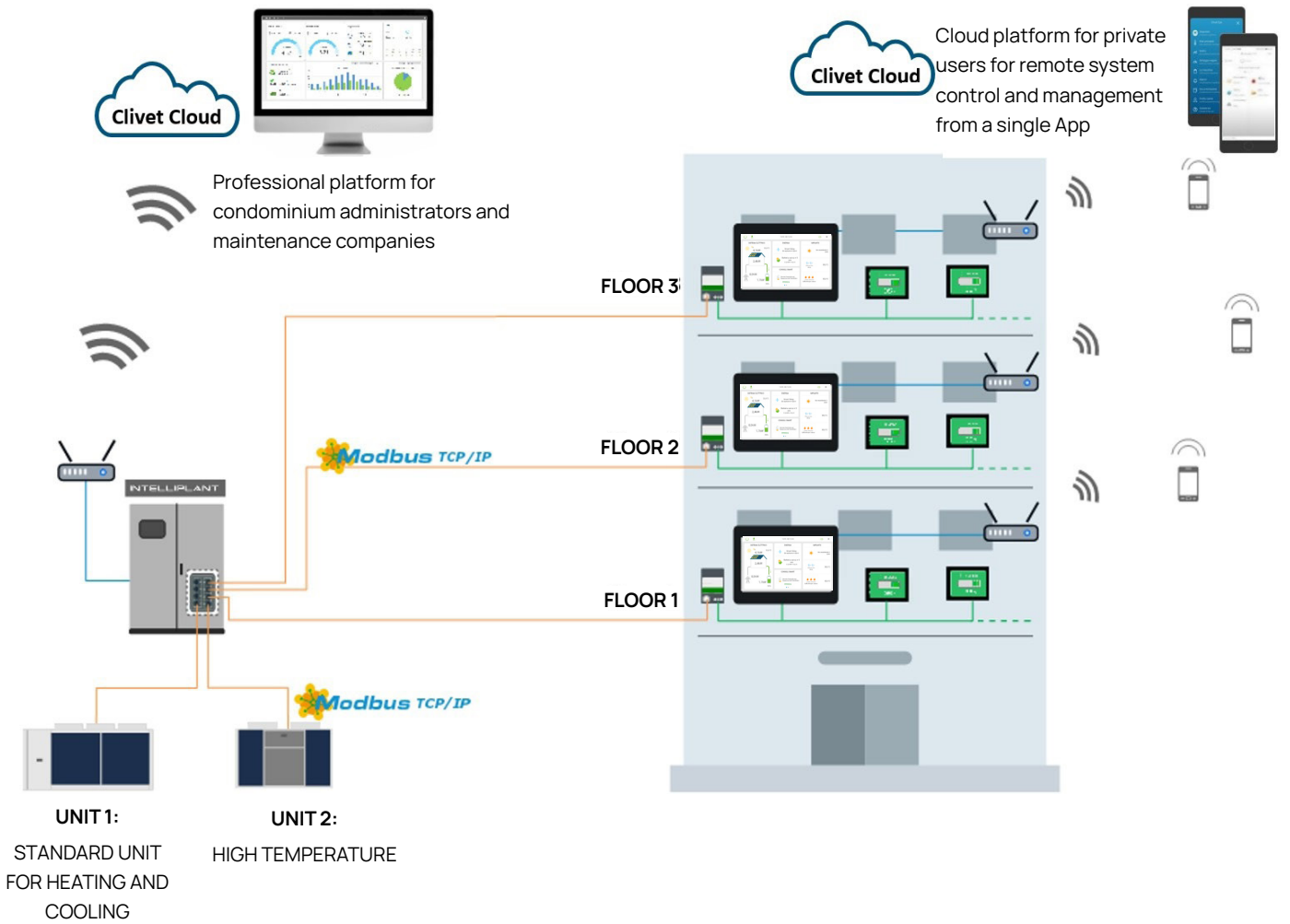

Central heating plant

The INTELLIPLANT system optimises the production and distribution of thermal energy up to the floors where the individual housing units are disconnected

INTELLIPLANT ensures proper management of the heating and cooling plant to guarantee continuity in the production of thermal energy while reducing energy consumption of the entire system.

More specifically, INTELLIPLANT ensures:

- ✓ Optimisation of heat pump operation and back-up device management.
- ✓ Domestic hot water production by means of specific heat pump systems for high temperature water production
- ✓ Management of antilegionella cycles
- ✓ Optimisation of primary and secondary circuit flow-rates
- ✓ Climate compensation based on operating conditions
- ✓ Remote management of system loads
- ✓ Integration with photovoltaic panels
- ✓ Energy page with system load profiles and generation of energy reports (includes flow and electricity meters in the central heating plant)
- ✓ Multi-site management of systems located across the country

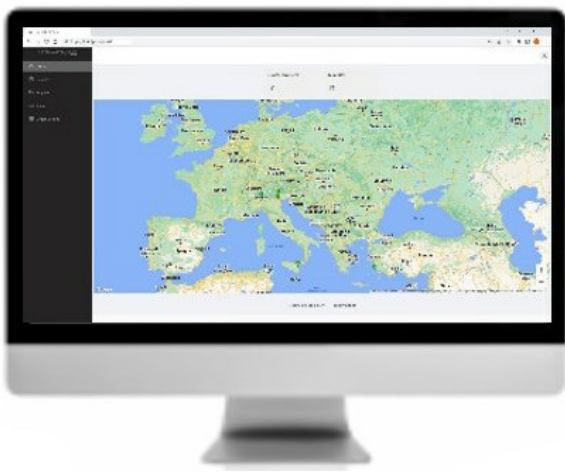

MULTI-SITE SYSTEM

Centralised management of sites located across the country from head office

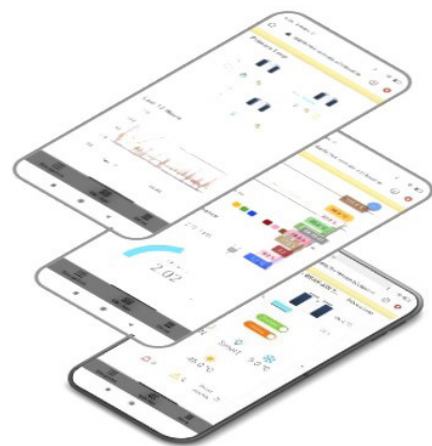

CLIVET CLOUD, THE SYSTEM IN YOUR HANDS

Responsive interface with remote access to all system sections for management by service centres and maintenance companies operating in the field

INTELLIPLANT CORE

Management and optimisation system for centralised residential systems

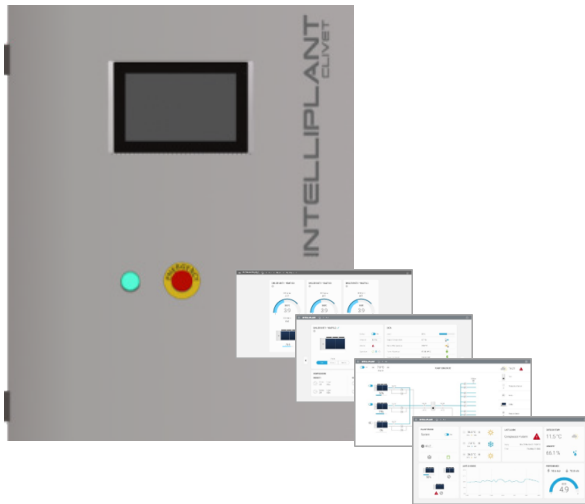

- ✓ Control and optimisation of heat pumps in centralised systems
- ✓ Backup boiler management
- ✓ Central heating plant and individual user consumption metering
- ✓ Housing unit management with Control4 NRG
- ✓ Local and remote management by administrators via cloud connection
- ✓ Multi-site platform for the remote management of different systems located across the country

Safety and professionalism

The INTELLIPLANT system separates the management of centralised systems by professionals from the management of residential environments by private users via two separate cloud platforms.

This allows condominium administrators and personnel to access the central heating plant without being given access to individual homes, while maintaining data protection privacy levels in accordance with the most stringent provisions of the GDPR (Global Data Protection Regulation).

At the same time, the owners and tenants of the various housing units can manage their own flat but not the centralised system, thus avoiding tampering or management problems of professional systems.

System managers

The INTELLIPLANT system allows you to efficiently and continuously manage the system on the local operator panel and the remote interface on a computer, smartphone or tablet.

- ✓ Secure management by connection to the Clivet cloud for professional environments
- ✓ Management of operating parameters such as temperature and seasonal mode change
- ✓ Scheduled and manual system switch-on
- ✓ Wear check of the main components
- ✓ Management of scheduled and preventive maintenance
- ✓ Online management of system documentation
- ✓ Lower maintenance costs, prevention of system downtime due to faults
- ✓ Management of thermal energy produced by the central heating plant and electricity consumption
- ✓ Calculation of system efficiency
- ✓ Consumption metering via connection to the CONTROL4 NRG energy assistants of the housing units

Private users

Each housing unit is managed by the CONTROL4 NRG energy assistant, which optimises room comfort while reducing energy consumption.

- ✓ Safe management by connection to CLIVET EYE for private-use residential environments
- ✓ Remote system management via the App for iOS and Android devices
- ✓ Separate management of zones and their comfort levels
- ✓ Compatibility with HID-TSmart thermostats to display the home operating parameters such as temperature, humidity, electricity consumption, air quality, SINERGY2 coil charge level (when present)

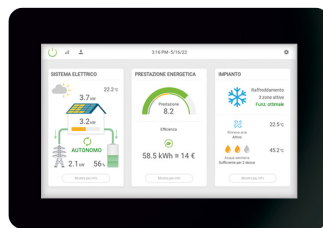

Example of infrastructure

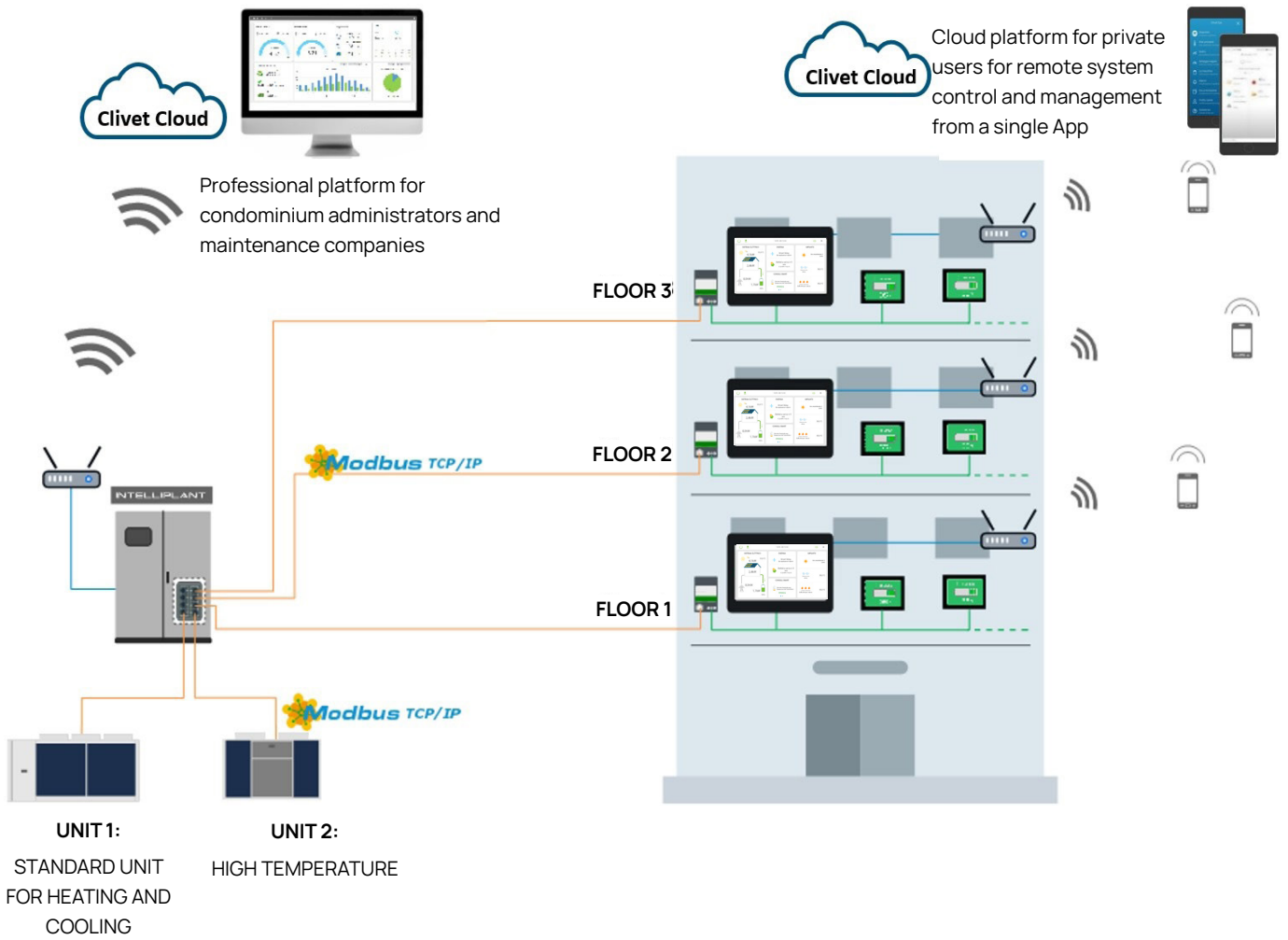

INDEX

RANGE	SIZE. FROM - TO	BRAND NAME	GROUP	PAG.
CiSDN-M EP 1 MR	3.1	Heat pump	FULLNESS	26
SQKN-YEE 1 TC E-XT + MiSAN-YEE 1 S	2.1 - 8.1	Heat pump	Sphera EVO 2.0	32
SQKN-YEE 1 BC E-XT + MiSAN-YEE 1 S	2.1 - 8.1	Heat pump	Sphera EVO 2.0 BOX	38
SQKN-YEE 1 IC + MiSAN-YEE 1 S	2.1 - 5.1	Heat pump	Sphera EVO 2.0 INVISIBLE	44
SQKN-YEE 1 BH + MiSAN-YEE 1 S	2.1 - 8.1	Heat pump	Sphera EVO 2.0 EASYHybrid Box	52
SQKN-YEE 1 BH + MiSAN-YEE 1 S	2.1 - 8.1	Heat pump	Sphera EVO 2.0 EASYHybrid TOWER	58
WiSAN-PMP 1 S	2.1 - 8.1	Heat pump	EDGE PRO	66
WiSAN-PMP 1 S	12.1 - 14.1	Heat pump	EDGE PRO L	70
WiSAN-PME 1 S	2.1 - 8.1	Heat pump	EDGE F	74
WiSAN-YME 1 S	2.1 - 14.1	Heat pump	Edge EVO 2.0 - EXC	78
WiSAN-YME 1 S - WiSAN-PME 1 S - WiSAN-PMP 1 S+ HQCN-NEE 1 TC A	2.1 - 8.1	Heat pump	HYDRO-SPLIT TOWER	88
WiSAN-YME 1 S - WiSAN-PME 1 S - WiSAN-PMP 1 S+ HQCN-NEE 1 BC	2.1 - 8.1	Heat pump	HYDRO-SPLIT BOX	98
WiSAN-YME 1 S - WiSAN-PME 1 S - WiSAN-PMP 1 S+ HQCN-NEE 1 IC	2.1 - 5.1	Heat pump	HYDRO-SPLIT INVISIBLE	108
WiSAN-YME 1 S - WiSAN-PME 1 S - WiSAN-PMP 1 S + HQCN-NEE 1 MC	2.1 - 8.1	Heat pump	HYDRO-SPLIT MINI	118
Gas Boiler FE	24.4-33.4	Heat pump	Gas Boiler FE	128
Gas Boiler UC	33.4+200F.2	Heat pump	Gas Boiler UC	129
F-L / F-XL / FH-XL		Heat pump	ELFOSUN3	132
Bollitori ACS	ACS200X - ACS10SX	Heat pump	DHW BOILER	136
CFW-2	1-5	Terminal units	MOOD	140
ELFOROOM2	003.0 - 017.0	Terminal units	ELFOROOM2	142
CFFAC / CFFAU	1-12	Terminal units	AURA - 3-speed version	146
CFFC / CFFU	1-12	Terminal units	AURA - Inverter version	150
CFK	007.0 - 041.0	Terminal units	ELFOSPACE BOX3	154
DUE-M1 / DUA-M1	12 - 122	Terminal units	LARICE MP	158
DUE-H1 / DUA-H1	12 - 64	Terminal units	LARICE HP	166
DSDH-P AQ 1 S	100	Heat pumps for DHW	AQUA F 100L	174
DSDH-P AQ 1 S	190 - 300	Heat pumps for DHW	AQUA F 190-300L	178
CPAN-YIN	SIZE2	VMC with recovery	ELFOFRESH EVO	184
AIRPATH		VMC with recovery	AIRPATH	188
CONTROL4 NRG		Solutions	CONTROL4 NRG	194
HEC2-S3.68Hr2, HEC2-S5.0Hr2, HEC2-S6.0Hr2		Solutions	SINERGY2	198
HEC2-T8.0Hr2-EU, HEC2-T10.0Hr2-EU, HEC2-T12.0Hr2-EU, HEC2-T15.0Hr2-EU		Solutions	SINERGY2	198
CLIVET EYE		Solutions	CLIVET EYE	208
HID-TConnect2		Solutions	HID-TConnect2	212
INTELLIPLANT		Solutions	INTELLIPLANT	216
INTELLIPLANT CORE		Solutions	INTELLIPLANT CORE	220

Clivet, in compliance with Regulation 517/2014, informs that its products contain or function with the use of fluorinated greenhouse gases: R-32 (GWP 675), R-410A (GWP 2087,5), R-134a (GWP 1430) and R-407C (GWP 1773,85), R-513A (GWP 631), R-1234ze (GWP 7).

Data contained in this catalogue are not binding and may be changed by the Manufacturer without notice.

No part of this publication may be reproduced.

Updated data available on www.clivet.com

Icons guide



ICONS GUIDE

ENERGY SAVING



Solar integration
Ideal for use with solar thermodynamic systems



Smart Grid ready
Ideal for integration with Smart Grid technology



Free Cooling / Heating
Provides Cooling / Heating for free (on certain conditions)



nZEB
Designed for buildings with almost no energy consumption



Cascade
Many units can be used together to provide big capacities



€-Switch
Activates the most cost-effective generator



Quick start-up
Quick system startup.



Class A environmental control
Ensures high levels of energy performance.



Weekly energy produced/ consumed dashboard
It allows for the display of energy produced by the photovoltaic system and consumed on a weekly basis



Total system management dashboard
Allows for the management and monitoring of the entire system.



Weekly energy accumulated dashboard
Allows for the display of accumulated energy on a weekly basis.



Heat pump set-point compensation
Enhances indoor comfort based on external temperature.



Energy meter
It allows for the display of energy produced by the photovoltaic system and consumed on a weekly basis

Comfort



Heating/Cooling
For both heating and cooling



DHW
Produces Domestic Hot Water



Dehumidification
Removes humidity in the room



Follow Me
Temperature sensor built in the remote controller will sense its surrounding temperature



Underfloor system, fancoils, radiators
Independent management of resources for the distribution of comfort



Silent
For more silent operation



Anti cold air
It does not supply air into the room until it is hot enough



Temperature compensation
Considers the stratification of air to create a fairer temperature



High temperature
Produces heating at high temperature



Summer, winter and DHW management
Comfort management for up to 24 independent climatic zones.



Humidity control
Independent humidity management for each zone.



Air quality renewal and monitoring
Monitoring and management of units for air quality renewal.



ECO
Programming of standard or eco setpoints independently for the 24 zones.



Differentiated temperatures per area
Independent comfort management for each zone.

RELIABILITY



Condensate drain pump
Condensate disposal with a dedicated pump



Backup heater
Fitted with an electric heater that can operate if necessary in Heating mode







Keymark
Performance certified by CEN



ProdottiQualità CasaClima
Product excellence certified by the KlimaHaus / CasaClima agency











HEALTH

-  **High Density filter**
Filters the air inlet
-  **Air renew**
Exchanges the air inside with air from the outside
-  **Air purification**
Purifies incoming air
-  **Eco-friendly refrigerant**
Uses environmentally friendly refrigerant.
-  **Renewable Energy**
Uses only renewable energy, with zero CO₂ emissions

CONVENIENCE

-  **Weekly Timer**
Weekly programmable settings (ON-OFF / temperature / ...)
-  **Integrated DHW tank**
Comprises a tank for the storage of Domestic Hot Water (DHW)
-  **Contemporaneity**
Produces Heating and Domestic Hot Water at the same time
-  **Instant DHW**
Quickly produces Domestic Hot Water on demand
-  **Away**
It is possible to set the comfort level to be maintained during the away mode
-  **Weather forecast**
Hourly weather forecast service available.
-  **Voice control**
Allows control of the system through voice commands.
-  **ON / OFF**
Turning on/off the entire system.
-  **Auxiliary load scheduling**
Allows scheduling the activation and deactivation of electrical loads.

Management and connectivity

-  **Input ON/OFF**
fitted with ON/OFF contact for management via remote device
-  **User interface / thermostat**
The user interface can be used as a thermostat
-  **Remote control**
Managed with the remote control
-  **Wired controller**
Managed with a wired control
-  **Centralised control**
Manageable through centralized controller
-  **Modbus port**
Provided with RS485 port
-  **Control via the App**
Can be managed via App
-  **Control4 NRG management**
Manageable with the intelligent centralized Control4 NRG system.
-  **Clivet Eye monitoring**
Can be monitored remotely with Clivet Eye
-  **Input 0-10V**
fitted with ON/OFF contact for management via remote device
-  **Output ON/OFF**
fitted with ON/OFF contact for managing an external device

For OVER 35 years we have been offering solutions for sustainable comfort and the well-being of people and the environment

CLIVET S.p.A.
Via Camp Lonc 25, Z.I. Villapaiera
32032, Feltre (BL) - Italy
Tel. +39 0439 3131 - info@clivet.it

CLIVET GMBH
info.de@clivet.com

CLIVET GROUP UK LTD
Enquiries@Clivetgroup.co.uk

CLIVET LLC
info.ru@clivet.com

CLIVET MIDEAST FZCO
info@clivet.ae

CLIVET SOUTH-EAST EUROPE D.O.O.
info.see@clivet.com

CLIVET FRANCE
info.fr@clivet.com

CLIVET AIRCONDITIONING SYSTEMS PVT LTD
sales.india@clivet.com



Valid from:
January 2026

DG26A002GB-00