

# Clivet Eye

## Manual for installation and use

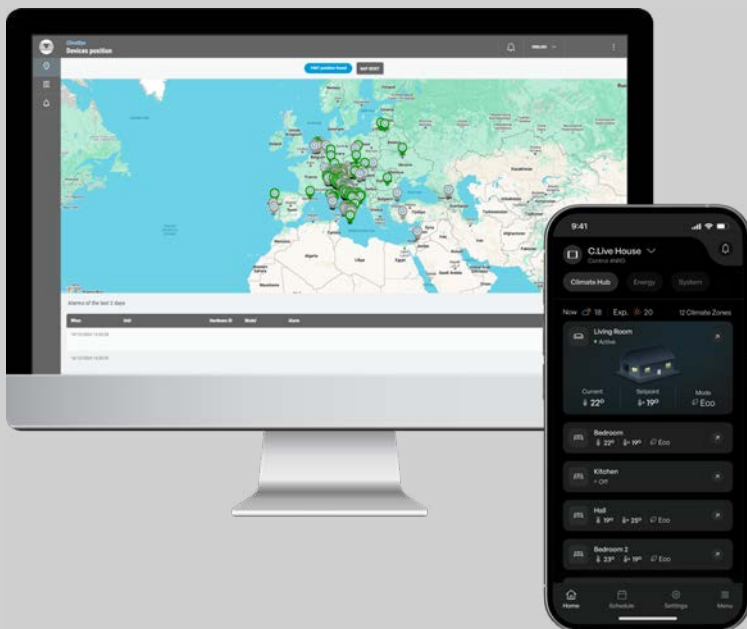

en

---

Dear Customer,

Congratulations for choosing this product

Clivet has been working for years to offer systems able to assure the maximum comfort for a long time with highly-reliable, efficient, high-quality and safe solutions.

The target of the company is to offer advanced systems, that assure the best comfort and reduce energy consumption as well as the installation and maintenance costs for the entire life-cycle of the system.

With this manual, we want to give you information that are useful for all phases: from reception, installation and use to disposal - so that such an advanced system can provide the best performances during installation and use.

Best regards and have a good read.

CLIVET Spa

The data contained in this manual is not binding and may be changed by the manufacturer without prior notice. Reproduction, even partial, is FORBIDDEN.

© Clivet S.p.A. - Feltre (BL) - Italia.

# Summary

<b>1.</b>	<b>Introduction</b> .....	<b>4</b>
<b>2.</b>	<b>Safety considerations.</b> .....	<b>4</b>
<b>3.</b>	<b>General requirements</b> .....	<b>5</b>
<b>4.</b>	<b>Monitoring kit</b> .....	<b>6</b>
4.1	i-Mobile (GSM connectivity): .....	6
4.2	i-Link (Ethernet connectivity): .....	7
<b>5.</b>	<b>Connections and configuration</b> .....	<b>8</b>
5.1	i Mobile.....	8
5.2	i-Link.....	9
5.2.1	LAN access configuration .....	9
<b>6.</b>	<b>Checking connections</b> .....	<b>11</b>
6.1	Power supply .....	11
6.2	RS485 .....	12
<b>7.</b>	<b>Troubleshooting</b> .....	<b>13</b>
7.1	The device does not connect .....	13
7.2	Unit data not updated and/or commands not working .....	13
<b>8.</b>	<b>User guide</b> .....	<b>14</b>
8.1	Login and menu .....	14
8.2	Device map and list.....	14
8.3	Dashboard and Widgets .....	15
8.4	Trend .....	15
8.5	Gauge .....	15
8.6	Alarms.....	16
8.7	Energy.....	16
8.8	Alarm history .....	16
8.9	Statuses and parameters.....	17
8.10	Configure trend.....	17
8.11	Calendar.....	18

## 1. Introduction

This manual provides information regarding the installation of the monitoring kit, in the versions available with GSM or Ethernet connectivity, for connection to the Clivet Eye Cloud platform of Clivet units.

Clivet S.p.A. shall not be held liable for malfunctions caused by incorrect setting of equipment operating parameters, incorrect laying of the data transmission cables or, in general, improper use of the supervision instrument.

► **Only qualified personnel can operate on the equipment, as required by the regulations in force.**

## 2. Safety considerations.

Prior to installation:

- Carefully read these instructions;
- Consult the unit manual.

Please follow the safety warnings in the unit manual.

All electrical operations should be performed by trained personnel having the necessary requirements by the regulations in force and being informed about the risks relevant to these activities.

Operate in compliance with safety regulations in force.

Store this manual for future needs.

### 3. General requirements

The kit can be installed:

- Inside the unit or in its electrical panel (check if there is a space for the wiring diagram);
- In an electrical panel external to the unit, with compliant IP specification for the place of installation.

For the RS485 connection use a shielded cable for serial lines; if not suitable for such use, it may affect correct data transmission.

- The insulation and voltage characteristics of the cable must be in accordance with the electrical regulations in force;
- The insulation of the cable must have flame or fire retarding characteristics, commensurate with the electrical standards of reference for the type of system used;
- The cable must be laid to standard;
- The cable must be laid separately from other cables, especially from power cables or from cables of different voltages;
- The cable must be laid far from cables or devices that can cause electromagnetic interference;
- The serial line must be laid by personnel trained and qualified in data communication networks.
- The maximum distance of the RS485 connection is **1000 m**.
- The shield of the serial cable must be connected to an earth free from interference;
- The shield must be earthed at one point only;

These provisions apply in general. In some areas characterised by the presence of particular types of EMI coupling, a different type of shield connection may be required.

**Do not install** in the following conditions:

- Where there is mineral oil, even in vapour form;
- Production sites of corrosive substances (e.g. sulphurous acid);
- Where there are sources of electromagnetic waves as they could disturb the control system and cause the devices to malfunction;
- Near potential flammable gas leaks, where there is carbon fibre or flammable dust in the air or in places where flammable substances such as thinners or petrol are handled;
- Where there is a high concentration of salt in the air;
- Where the power supply voltage is subject to instability;
- Near wheeled vehicles or ships;
- Where there are acid or alkaline vapours;

► **Where applicable, do not install the antenna inside metal structures.**



## 4. Monitoring kit

The monitoring kit contains:

- Ethernet version module (i-Link or GSM) (i-Mobile)
- 230V/12Vac transformer to power the module
- GSM antenna and SIM card (only for i-Mobile)
- User license

► A kit can be combined with a single Clivet unit.

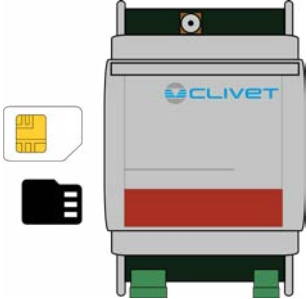
### 4.1 i-Mobile (GSM connectivity):

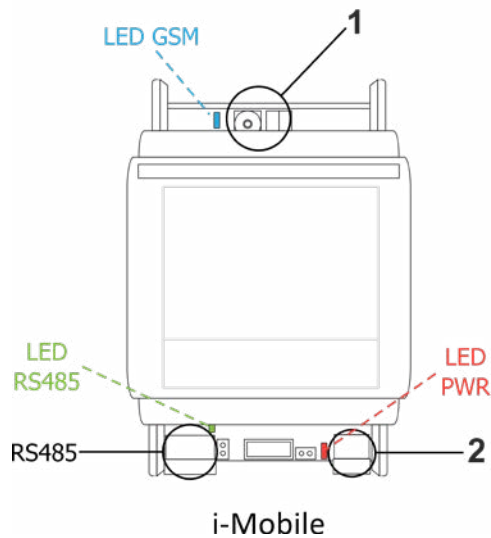

		
230V/12Vac transformer	Modbus RTU GSM communication module	GSM antenna cable for outdoor installation



- 1 Antenna connector
- 2 Power supply

► The SIM provided is only valid for installations within the EU area.

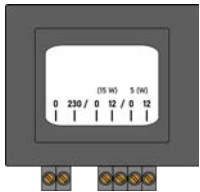
## 4.2 i-Link (Ethernet connectivity):

	
230V/12Vac transformer	Modbus RTU ETH communication module

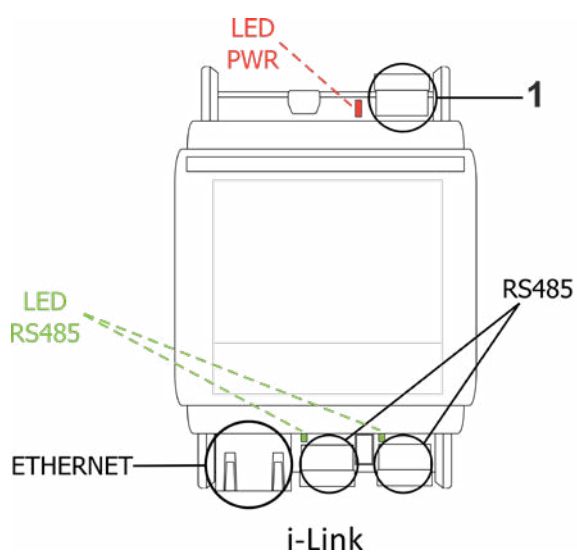

1 Power supply

Components to be provided by the customer:

- Connection cable between 230V/12Vac transformer and module;
- RS485 serial connection cable between modem and Clivet unit.
- Ethernet cable (only for i-Link version)

## 5. Connections and configuration

The unit is to be configured with:

- Address: 1
- Baud rate: 9600
- Data bit: 8
- Parity: None

► For remote control to work, the unit must be set to local priority where applicable and parameter writing via Modbus connection must be enabled. Check the unit manual on how to make the configurations.

### 5.1 i Mobile

- Connect the modem to the unit with the RS-485. Check the unit manual on how to make the Modbus RS485 connection;
- Connect the antenna;
- Check that the SD card and SIM are present;
- Connect the power supply.

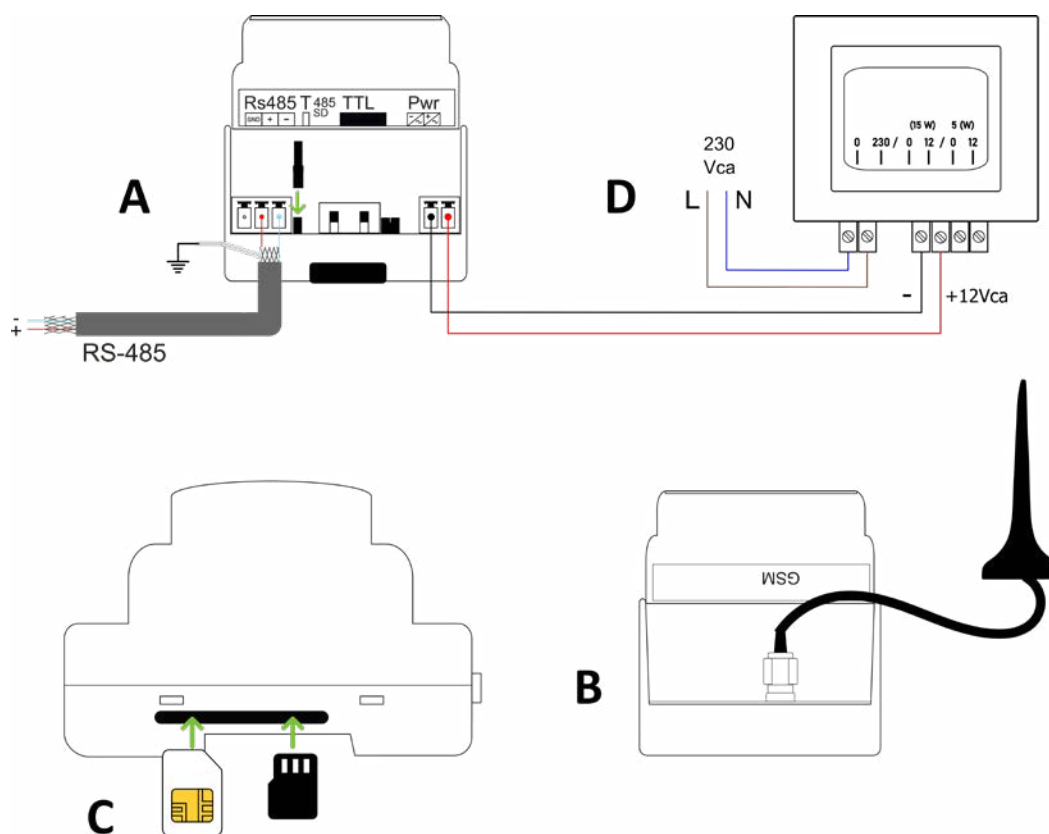

## 5.2 i-Link

- Connect the modem to the unit with the RS-485. Check the unit manual on how to make the Modbus RS485 connection;
- Connect the Ethernet cable to the module and to the network router;
- Connect the power supply.

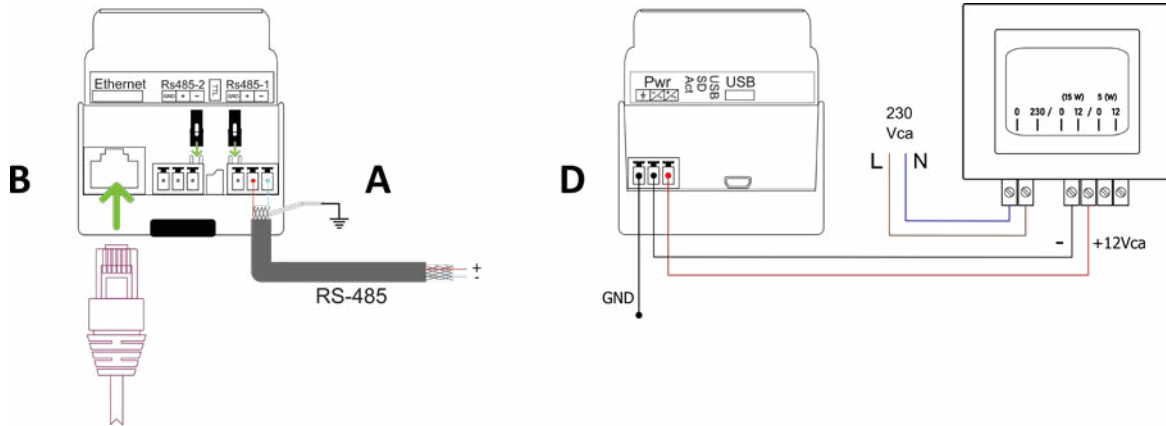

► For ElfoControlEVO units, the module's RS485-2 serial port is to be used.

### 5.2.1 LAN access configuration

The following steps must be carried out to configure the local area network access settings of the i-Link module.

The following are required for the procedure:

- Ethernet cable
- PC with Web browser and access to network board settings
- Configuration to be used (IP, Netmask, Gateway), provided by the network administrator.

Throughout the procedure, the i-Link module must always be connected to the PC via Ethernet cable and be correctly powered as described in the document.

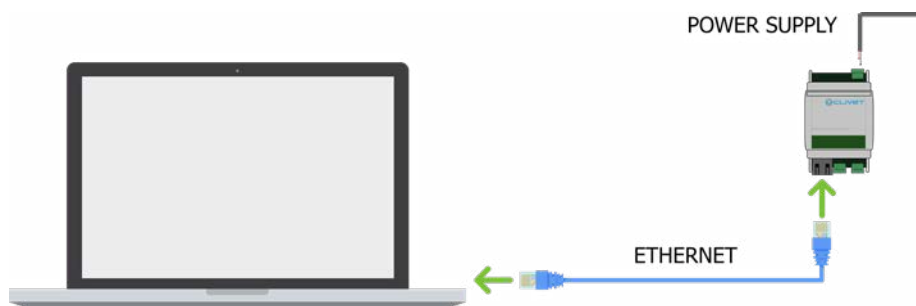

In order to access the i-Link module settings, it is essential to know the IP address that is currently set.

By default, the module is available with IP address **192.168.0.102**.

If it has been previously configured, refer to the current setting.

## Step 1

Ensure that the PC's network board is configured with an IP address that is compatible with that of the i-Link module. (e.g. i-Link IP: **192.168.0.102**, network board IP: **192.168.0.10**).

If necessary, configure your network board following the procedure for the operating system used on your PC

To access the i-Link module settings, log in to the browser's Web Server by entering the module's IP address into the search bar of your web browser.



## Step 2

From the Web Server's home page, log in by pressing the button at top right and entering your credentials:

- User name: user
- Password: user



### ► Only edit the fields indicated in the guide so as not to affect operation of the device.

In the left menu select Settings -> Network where the network configuration parameters to be edited are listed

- Static IP
- Static Netmask
- Static Gateway



Fill in the fields with the required specifications, saving one line at a time by pressing the “SET” icon.

If network access is set to DHCP (i.e. with dynamic IP address), the fields will be set to 0.

### ► Leave the Static DNS field unchanged.

To apply the changes, close the browser and disconnect the i-Link module; the new configuration will be effective when the module is restarted

## 6. Checking connections

### 6.1 Power supply

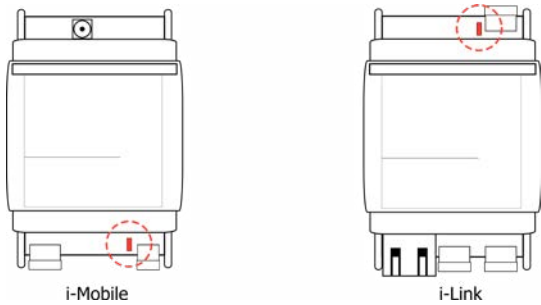

The **PWR** LED indicates correct power supply when on, power problems if off.

Mobile network connection (only i-Mobile)

Check the connection status to the GSM network via the GSM LED near the antenna connector:



No activity:



Network search:

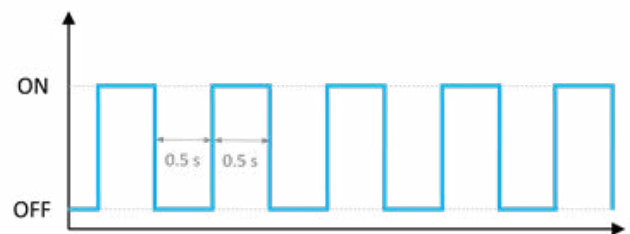

Connecting:

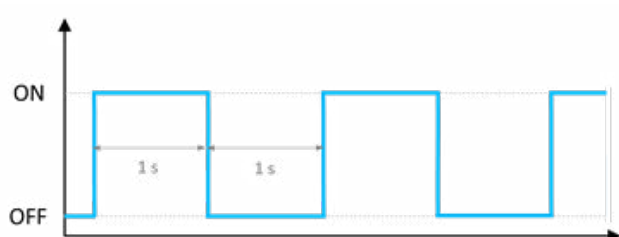

Connected:

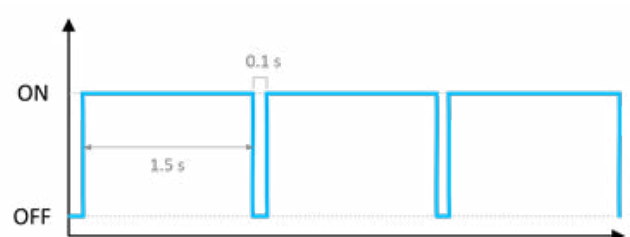

## 6.2 RS485

Check the activity flashes of the **RS485 LEDs** via the LEDs next to the module's 485 port and the power LED next to the PWR terminal:

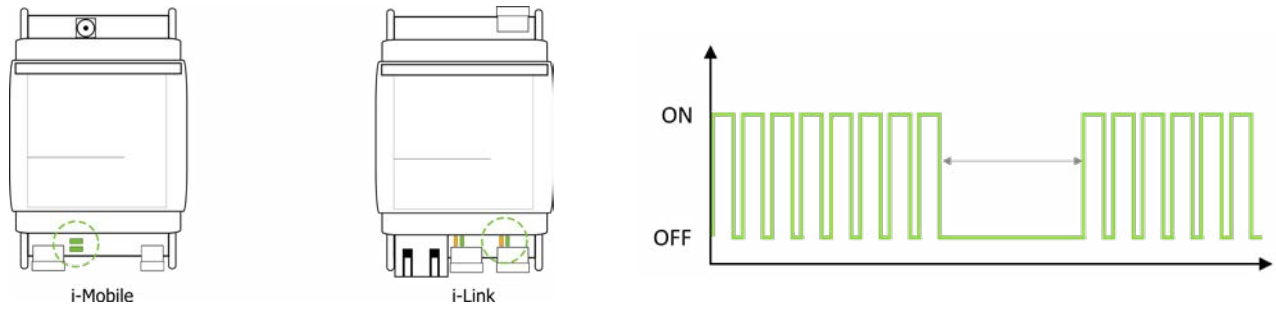

Any other action is deemed a serial communication error.

By default, the sampling interval is set to **60 seconds**.

- **Once the corrections have been made and the device is working properly, the monitoring data will be visible on the platform after a few minutes.**

## 7. Troubleshooting

### 7.1 The device does not connect

#### **i-Mobile:**

First check that the cloud connection LED flashes as indicated in section 6. The causes can be attributed to:

- **No GSM coverage;** in this case, check that the site has adequate signal coverage and ensure that the antenna is placed outside any metal containers;
- **SIM tariff plan not active;** check that the SIM inserted is correctly activated and the tariff plan is consistent with the geographical area of the installation.

#### **i-Link:**

Check that the local area network is working properly. If it is. The i-Link module may not be connected due to:

- **Incorrect connection of the Ethernet cable** from the module to the router;
- **Incompatibility with the internet network policy** of the site. If necessary, reconfigure the i-Link module's access settings as instructed in this manual.

### 7.2 Unit data not updated and/or commands not working

If the device is correctly connected to the network, but no real-time data (for the last few minutes) are displayed and/or the commands sent to the unit have failed, there is a serial connection error between the module and the unit:

- 1 Check that the serial LED flashes as described in section 6;
- 2 Check that the RS485 serial cable is connected properly;
- 3 Check that the Modbus communication parameters are correct, including unit addressing;
- 4 Check the Modbus RS485 connection procedure in the unit manual.



## 8. User guide

### 8.1 Login and menu

Go to <https://www.cliveteye.com> and log in with your personal credentials.





After logging in, the screen displaying the map and alarm report for the last two days of the controlled units will open.

On the left, the menu provides access to the sections available:

-  Device map
-  Device list
-  Alarm history





### 8.2 Device map and list

If geolocation of the device is indicated, it is shown on the map at the specified location by an icon that changes according to status:

Icona	Description
	Online and no alarm in progress
	Offline
	Serious alarms in progress
	Minor alarms in progress

Each unit connected is registered by its Serial Number, HW ID (unique device identifier on the platform) and label (can be changed by the user).

Clicking on the icon will display the unit's details and open the operating statuses.

Icona	Description
	Dashboard
	Configure trend
	Statuses and parameters
	Properties
	Energy page*

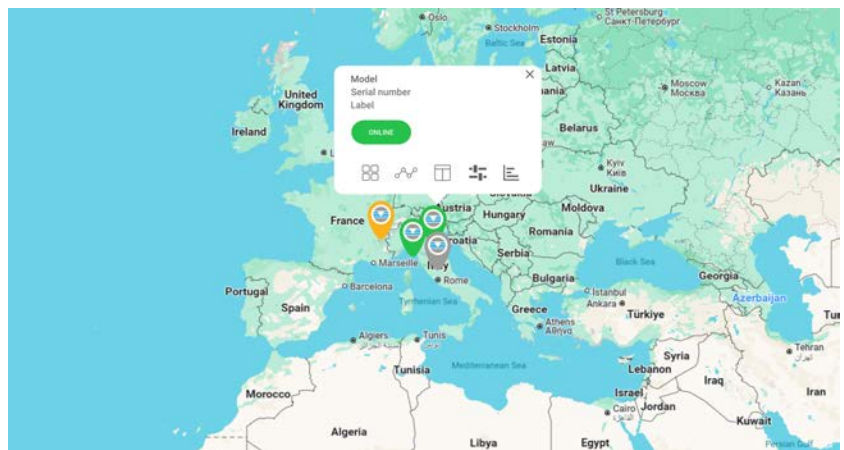

\*Only if the unit's power consumption and energy output data are available

The device list provides access to the same information given for the Map, but with a list view of the controlled units.

You can search by serial number, Hardware ID and product family.

### 8.3 Dashboard and Widgets

The dashboard shows the main operation data. The values available can be shown in different types of Widget:

#### Status



It can depict the unit's raw data (e.g. temperature), an operation status with an icon (e.g. heating) or a label (e.g. "Connected").

### 8.4 Trend

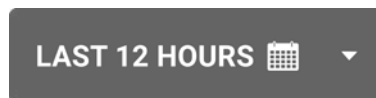

Every variable displayed has a corresponding colour shown in the key on the right. The graphs are interactive and each sample shows its date and time.

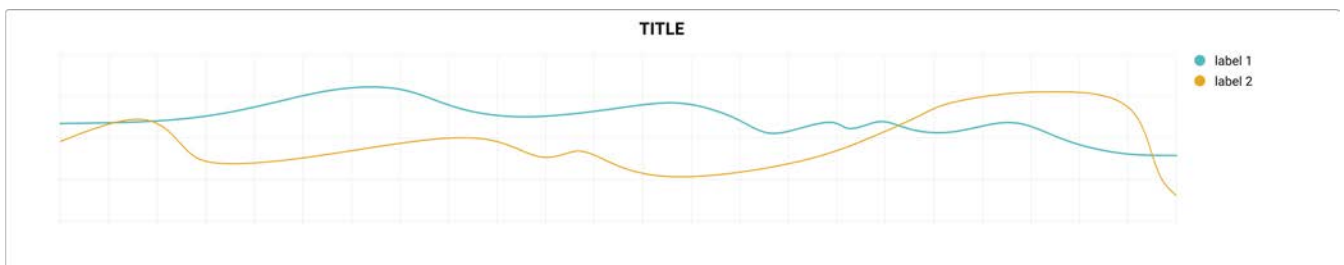

### 8.5 Gauge

Displays percentage values in the form of a circular loading bar. It is used for data with values between 0 and 100 such as, for example, the unit's percentage of ventilation applied or capacity applied.

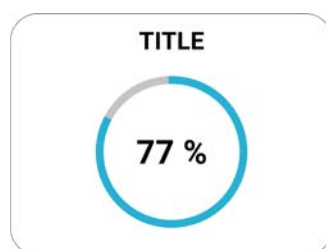

## 8.6 Alarms

The specific alarms in progress (not the presence or absence of an alarm) are displayed in a table-type widget containing the date and description of the anomaly event.

Channel	When	Alarms
Hydraulic alarms	11/08/2023 16:26	Water flow error

These fields are also shown in the Alarm History section.

## 8.7 Energy

The energy report page is available for units for which energy consumption and/or production data are included.

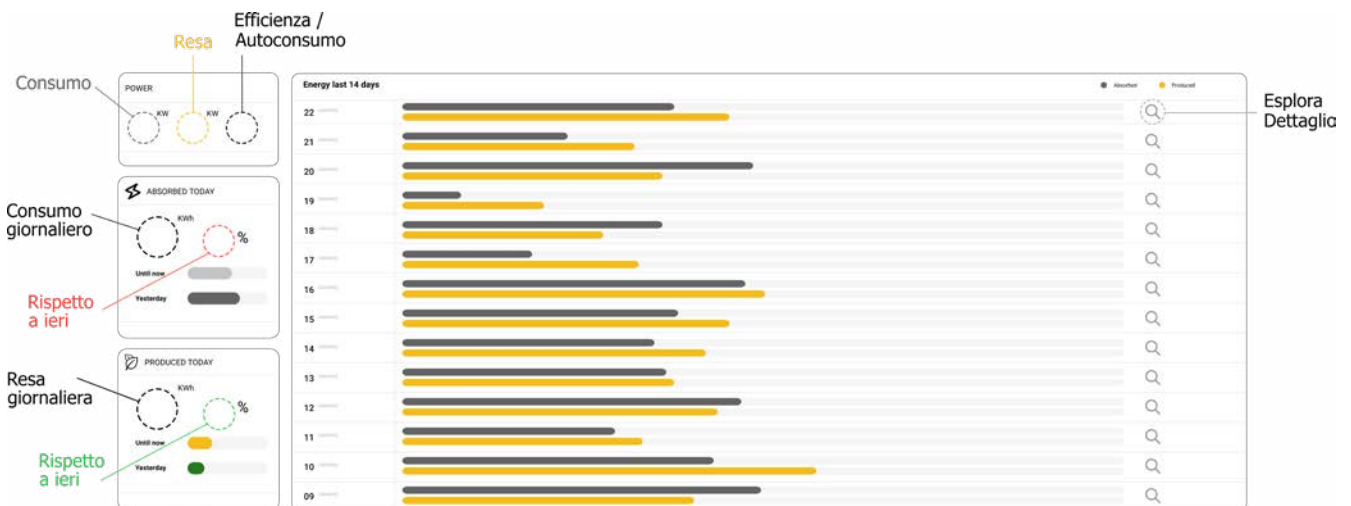

The daily detail displays the following:

- Trend over time of energy consumed and performance per hour
- Hourly efficiency
- Trend over time of instantaneous consumption, performance and efficiency
- Distribution of consumption (only for ElfoControlEVO & Control4 NRG)







## 8.8 Alarm history

This page provides a list of the anomalies found for all the devices controlled by the user.

Each line in the table shows

- 1 Alarm date and time
- 2 Unit's label
- 3 Unit's Hardware ID
- 4 Model
- 5 Description of the anomaly
- 6 Anomaly status (in progress or cleared)

The list allows you to filter by individual unit using the hardware ID and consult the history for up to a maximum of 30 days (set at 2 days by default)

1 When	2 Unit	3 Hardware ID	4 Model	5 Description	6 Alarm recovered
11/08/2023 16:26	Clivet unit 1	SW-001	Model 1	Water flow error	   
10/08/2023 10:55	Clivet unit 2	SR-002	Model 2	Error outdoor temperature probe	10/08/2023 12:03   

The list selected can be downloaded in CSV format by pressing “Export CSV”.

EXPORT CSV

### 8.9 Statuses and parameters

The unit’s operation data and settings can be viewed in list format in the “Statuses and Parameters” section.

The left column displays read-only data, the right one displays the last relevant available value.

### 8.10 Configure trend

Selected sizes can be trended by configuring customised graphs.

After pressing “Configure graph”:

- 1 Choose the variable to be graphed from those available
- 2 [OPTIONAL] Set the track colour (a default colour will be used if this is not set)
- 3 [OPTIONAL] Select the scale to be used from those created in the “Scale” tab
- 4 [OPTIONAL] Set the background colour and position of the key in the “Other” tab
- 5 Add the variable to the graph by pressing the save icon
- 6 Press the “Save” button to display the graph set

Each variable can be deselected to temporarily exclude it from the trend, whereas if a variable from those included has no values for the range set at top left, it will not be shown in the graph.

Press the “Other” button at top right to select “Export data”:

The summary window shows which data will be included and allows you to set the time interval. Once “Export” has been pressed, a file will be downloaded in CSV format.

## 8.11 Calendar

It is possible to schedule commands to be sent to the unit.





To do this, add an event to the list by pressing “Add” and fill in the form with:

- 1 Event name (e.g. “Daily switch-on”)
- 2 Command and setting to be applied
- 3 Hour and minutes
- 4 Repetition (whether every day or only on certain days of the week)
- 5 [OPTIONAL] Event validity period (e.g. if it relates only to the summer season, the event may be valid from 1st May to 30th September)
- 6 Email address to which the missed command application should be sent

The screenshot shows a 'CONFIGURE EVENT' form with the following fields and controls:

- Event name:** A text input field with a red border and a red '1' next to it.
- Enable/Disable:** A toggle switch currently turned on.
- Action:** A dropdown menu with a red border and a red '2' next to it.
- Value:** A dropdown menu with a red border and a red '2' next to it.
- Hour:** A dropdown menu with a red border and a red '3' next to it.
- Minutes:** A dropdown menu with a red border and a red '3' next to it.
- Days:** A row of buttons for MONDAY, TUESDAY, WEDNESDAY, THURSDAY, FRIDAY, SATURDAY, and SUNDAY, with a red '4' next to the row.
- Months:** A grid of buttons for JANUARY, FEBRUARY, MARCH, APRIL, MAY, JUNE, JULY, AUGUST, SEPTEMBER, OCTOBER, NOVEMBER, and DECEMBER, with a red '4' next to the grid.
- Valid from (optional):** A dropdown menu with a red border and a red '5' next to it.
- Valid to (optional):** A dropdown menu with a red border and a red '5' next to it.
- Email address:** A text input field with a red border and a red '6' next to it.
- Buttons:** 'SAVE' (dark grey), 'CANCEL' (light grey), and 'DELETE' (red text).

The currently configured events are displayed in a list

Event	Setting	Next setting	Valid	Enabled
Accendi	Stato unità, ON	19/11/2024 8:15	Always	✓  
Spegni	Stato unità, OFF	18/11/2024 11:30	1/10/2024 - 31/03/2025	✓  

From where the event can be disabled/enabled, edited and deleted.

The Holiday days calendar allows you to add dates for your device on which the schedule of enabled events will be excluded.

(for example, exclude the scheduled switch-on of the unit during building closure days known to the user)

The screenshot shows a 'Holiday days' form with the following elements:

- Header:** 'Holiday days' in a dark grey bar.
- Text:** 'Selected date periods will be excluded from active schedules'.
- Form:** 'Dates to be excluded' section with 'from' and 'to' dropdown menus, a trash icon, and a plus sign button.
- Buttons:** 'ANNULLA' (light grey) and 'SALVA' (dark grey) buttons at the bottom right.

Lastly, indicate the email address(es) to which any missed command applications should be reported.

Page intentionally left blank

FOR OVER 35 YEARS WE HAVE BEEN  
OFFERING SOLUTIONS FOR SUSTAINABLE  
COMFORT AND THE WELL-BEING OF  
PEOPLE AND THE ENVIRONMENT

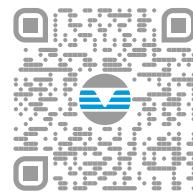

sales and assistance

Info & Contacts: [www.clivet.com](http://www.clivet.com)

