

THUNDER

Air-cooled reversible heat pump for outdoor installation

Capacity from 34,9 to 72,7 kW

DC INVERTER



Clivet participates in the EUROVENT "Liquid Chilling Packages and Hydronic Heat Pumps".
Check ongoing validity of certificate on www.eurovent-certification.com



Heat pump



Air cooled



Outdoor installation



R-290



Hermetic Scroll



Full inverter



Electronic expansion valve



CONTROL4 NRG management



INTELLIPLANT



compliant ErP

- ✓ Full inverter technology with scroll compressors
- ✓ High-temperature solution with modular approach
- ✓ Natural and environmentally friendly refrigerant R290 - GWP = 3
- ✓ High full load and seasonal efficiency with compact dimensions
- ✓ Hot water up to 75°C and wide operating range down to -20°C
- ✓ Three acoustic configurations: standard, silent and super-silent
- ✓ Modular design for up to 16 units in parallel (reduced installation space, enhanced system efficiency)

Versions and configurations

TYPE OF FANS:

VENDC DC high efficiency fan (Standard)

ACOUSTIC CONFIGURATION:

SC Acoustic configuration with compressor soundproofing (Standard)
LN Silenced acoustic configuration
EN Supersilenced acoustic configuration

Dimensions and connections

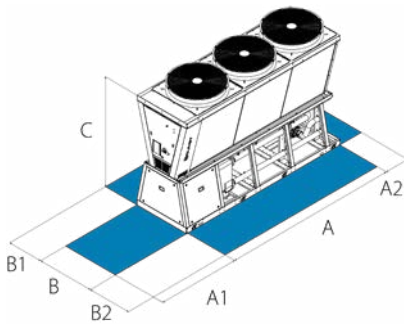

Size	WISAN-P	14.1	16.1	18.1	19.1	20.1	25.2	30.2
A - Length	mm	2384	2384	2384	2384	2384	3402	3402
B - Width	mm	1094	1094	1094	1094	1094	1094	1094
C - Height	mm	2240	2240	2240	2240	2240	2240	2240
A1	mm	1200	1200	1200	1200	1200	1200	1200
A2	mm	500	500	500	500	500	500	500
B1	mm	500	500	500	500	500	500	500
B2	mm	500	500	500	500	500	500	500
Operating weight	kg	709	709	757	757	757	1021	1021

The above mentioned data are referred to standard units for the constructive configurations indicated. For all the other configurations, refer to the relative Technical Bulletin.

CAUTION!
For trouble-free operation of the unit it is essential to maintain the safety distances indicated by the blue areas.

Technical data

Size	WISAN-P	14.1	16.1	18.1	19.1	20.1	25.2	30.2
Cooling capacity (EN 14511:2022)	(1) kW	34,9	38,5	49,9	54,0	58,2	67,8	72,7
Total power input (EN 14511:2022)	(1) kW	12,3	13,7	19,4	22,0	24,8	23,7	27,5
EER (EN 14511:2022)	(1) -	2,84	2,81	2,58	2,46	2,35	2,86	2,64
SEER	-	5,36	5,20	4,73	4,58	4,36	5,47	5,30
$n_{s,c}$	%	211,0	205,0	186,0	180,0	171,0	216,0	209,0
Heating capacity (EN 14511:2022)	(2) kW	39,9	45,2	55,1	61,5	68,5	78,6	85,9
Total power input (EN 14511:2022)	(2) kW	12,8	14,7	17,2	19,7	23,4	25,0	28,5
COP (EN 14511:2022)	(2) -	3,11	3,08	3,19	3,13	2,92	3,14	3,01
Refrigeration circuits	Nr	1						
No. of compressors	Nr	1						2
Type of compressors	-	SCROLL INVERTER						
Refrigerant	-	R-290						
Standard airflow	l/s	10556	10556	10556	10556	10556	14722	14722
Standard power supply	V	400/3/50						
Sound power level (SC)	(3) dB(A)	75	75	77	77	78	78	79
Sound power level (LN)	(3) dB(A)	73	73	74	74	74	74	75
Sound power level (EN)	(3) dB(A)	69	69	69	69	69	69	69
Directive ErP (Energy Related Products)								
ErP Energy Class - AVERAGE Climate - W35	-	A+++	A+++	A++	A++	A++	A+++	A+++
ErP Energy Class - AVERAGE Climate - W35	-	A++	A++	A++	A++	A++	A++	A++
SCOP - AVERAGE Climate - W35	(4) -	4,51	4,45	4,36	3,29	4,22	4,70	4,54
$n_{s,h}$	(4) %	177	175	169	166	163	185	179
SCOP - AVERAGE Climate - W55	(4) -	3,54	3,51	3,51	3,47	3,41	3,63	3,60
$n_{s,h}$	(4) %	139	137	133	132	131	142	141

(1) Data calculated in compliance with Standard EN 14511:2022 referred to the following conditions: Internal exchanger water temperature = 12/7°C; Outdoor heat exchanger inlet air temperature = 35°C

(2) Data calculated in compliance with Standard EN 14511:2022 referred to the following conditions: Internal exchanger water temperature = 40/45°C; Outdoor heat exchanger inlet air temperature 7 D.B. /6 (°C) W.B.

(3) Sound pressure levels are referred to units operating at nominal load in nominal conditions. Measurements are carried out accordingly to UNI EN ISO 9614-1 at nominal standard conditions defined in respective regulations: EU 2016/2281, UE 813/2013, UE 811/2013.

(4) Data calculated according to the EN 14825:2022 Regulation

The Product is compliant with the Erp (Energy Related Products) European Directive. It includes the Commission delegated Regulation (EU) No 811/2013 (rated heat output ≤70 kW at specified reference conditions), the Commission delegated Regulation (EU) No 813/2013 (rated heat output ≤400 kW at specified reference conditions).

Accessories

HYGU1V	User side hydronic assembly with 1 inverter pump	3DHW	Three-way valve for domestic hot water
1+1HYGU1V	Hydronic unit on user side with 1+1 inverter pump	3DHWX	Three-way valve for domestic hot water
ACIMP	Steel inertial storage tank	VSAX	automatic vent valve
IFWX	Steel mesh filter on the water side	TRAMBX	Remote user keypad to control the main functions of the unit
IFWI	Steel mesh strainer on the water side include in the packaging	AVIBX	Anti-vibration mount support
AMODX	Water fittings for modular unit	AVIBI	Advanced remote control module for auxiliary controls of sheen/storm units
CCKMUX	Pipe plug kit for modular units	AMMSX	Spring anti-seismic antivibration mounts
PGFC	Finned coil protection grilles	IOTX	IoT industrial module for cloud based interoperability & services
PGFCX	Finned coil protection grilles		
CCCA	Copper / aluminium condenser coil with acrylic lining		
CCCA1	Condenser coil with Aluminium Energy Guard DCC treatment		

Accessories whose code ends with "X" are supplied separately