

WSAT-YES

18.2 - 35.2

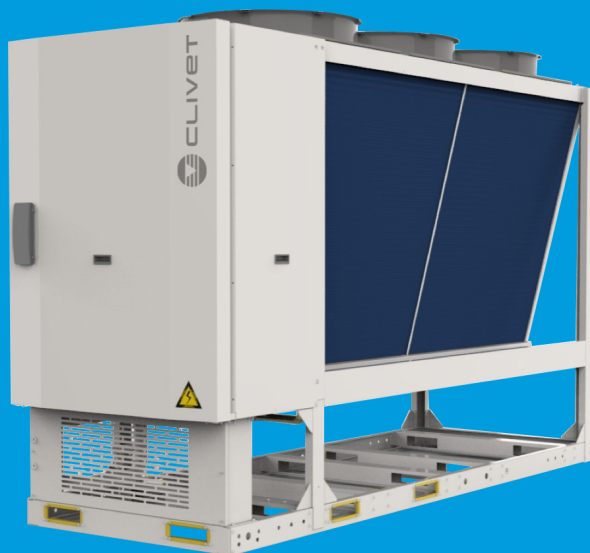

MANUAL

FOR INSTALLATION,
USE AND MAINTENANCE

MOSF00004-02 - 06/2021

R32

Dear Customer,

We congratulate you on choosing these product.

Clivet is being working for years to offer systems able to assure the maximum comfort for long time with high reliability, efficiency , quality and safety. The target of the company is to offer advanced systems, that assure the best comfort, reduce the energy consumption, the installation and maintenance costs for all the life-cycle of the system.

With this manual, we want to give you information that are useful in all the phases: from the reception, to the installation and use until the disposal so that a system so advanced offers the best procedure of installation and use.

Best regards and have a nice reading !

CLIVET Spa

The data contained in this manual is not binding and may be changed by the manufacturer without prior notice. All reproduction, even partial, is prohibited. © Copyright - CLIVET S.p.A. - Feltre (BL) - Italia

1	Safety considerations	4
2	Before installation	7
3	Handling	8
4	Selecting the installation site	9
5	Water connections	13
6	Electrical connections	20
7	Start-up	29
8	Control	36
9	Troubleshooting	42
10	Maintenance	48
11	Decommissioning	59
12	Residual risks	60
13	Technical information	62

1 SAFETY CONSIDERATIONS

Safety

Operate in compliance with safety regulations in force .
Use single protection devices: gloves, glasses, helmet etc.

Manual

The manual provides correct unit installation, use and maintenance.
It is advisable to read it carefully so you will save time during operations.
Follow the written indications so you will not cause damages to things and injuries people.

Preliminaries

Only qualified personnel can operate on the unit, as required by the regulation in force.

Risk situations

The unit has been designed and created to prevent injures to people.
During designing it is not possible to plane and operate on all risk situation.
Read carefully “Residual risk” section where all situation which may cause damages to things and injuries to people are reported.
Installation, starting, maintenance and repair required specific knowledge; if they are carried out by inexperienced personnel, they may cause damages to things and injuries people.

Intended use

Use the unit only:

- cooling water or a water and glycol mix for air-conditioning
- keep to the limits foreseen in the technical schedule and in this manual

The manufacturer accepts no responsibility if the equipment is used for any purpose other than the intended use.

Installation

Outdoor installation

The positioning, hydraulic system, refrigerating, electrics and the ducting of the air must be determined by the system designer in accordance with local regulations in force.

Follow local safety regulations.

Verify that the electrical line characteristics are in compliance with data quotes on the unit serial number label.

Maintenance

Plan periodic inspection and maintenance in order to avoid or reduce repairing costs.

Turn the unit off before any operation.



Pay particular attention to:

⇒ warnings / prohibitions / danger indicating particularly important operations or information, operations that cannot be done, which compromise the functionality of the unit or which may cause damage to things or persons.

Before any work read:

⇒ *Chapter. MAINTENANCE SAFETY WARNINGS FOR OPERATIONS ON UNITS CONTAINING R32*



Outdoor installation

Modification

All unit modifications will end the warranty coverage and the manufacturer responsibility.

Breakdown/Malfunction

Disable the unit immediately in case of breakdown or malfunction.

Contact a certified service agent.

Use original spares parts only.

Using the unit in case of breakdown or malfunction:

- voids the warranty
- it may compromise the safety of the unit
- it may increase time and repair costs

User training

The installer has to train the user on:

- start-up/shutdown
- set points change
- standby mode
- maintenance
- what to do / what not to do in case of breakdown.

Data update

Continual product improvements may imply manual data changes.

Visit manufacturer web site for updated data.

Indications for the User

Keep this manual with the wiring diagram in an accessible place for the operator.

Note the unit data label so you can provide them to the assistance centre in case of intervention (see “Unit identification” section).

Provide a unit notebook that allows any interventions carried out on the unit to be noted and tracked making it easier to suitably note the various interventions and aids the search for any breakdowns.

In case of breakdown or malfunction

- Immediately deactivate the unit
- Contact a service centre authorized by the manufacturer

The installer must train the user, particularly on:

- Start-up/shutdown
- Set points change
- Standby mode
- Maintenance
- What to do / what not to do in case of breakdown

Unit identification

The serial number label is positioned on the unit and allows to identify all the unit features.

The matriculation plate shows the indications foreseen by the standards, in particular:

- unit type
- serial number (12 characters)
- year of manufacture
- wiring diagram number
- electrical data
- type of refrigerant
- refrigerant charge
- manufacturer logo and address

The matriculation plate must never be removed.

It contains fluorinated greenhouse gases.

Serial number

It identifies uniquely each unit.

Must be quoted when ordering spare parts.

Assistance request

Note data from the serial number label and write them in the chart on side, so you will find them easily when needed.

Characteristics of R32 refrigerant:

- minimum environmental impact thanks to the low Global Warming Potential GWP
- low flammability, class A2L according to ISO 817
- low combustion speed
- low toxicity

Serie
Size
Serial number
Year of manufacture
Wiring diagram

Physical characteristics of the R32 refrigerant		
Safety class (ISO 817)	A2L	
GWP	675	
LFL Low flammability limit	0.307	kg/m ³ @ 60°C
BV Burning velocity	6,7	cm/s
Boiling point	-52	°C
GWP	675	100 yr ITH
GWP	677	ARS 100 yr ITH
Self-ignition temperature	648	°C

2 BEFORE INSTALLATION

Reception

You have to check before accepting the delivery:

- That the unit hasn't been damaged during transport
- That the materials delivered correspond with that indicated on the transport document comparing the data with the identification label positioned on the packaging.

In case of damage or anomaly:

- write down on the transport document the damage you found and quote this sentence: "Conditional acceptance clear evidence of deficiencies/damages during transport"
- contact by fax and registered mail with advice of receipt to supplier and the carrier.

NOTE

⇒ Any disputes must be made within 8 days from the date of the delivery. Complaints after this period are invalid.

Storage

Respect the indications on the outside of the pack.

In particular:

- ⇒ minimum ambient temperature -15°C
(possible components damages)
- ⇒ maximum ambient temperature $+49^{\circ}\text{C}$
(possible safety valve opening)
- ⇒ maximum relative humidity 95%
(possible damages to electrical components)

NOTE

⇒ The unit may not be tilted more than 15° during transport.

NOTE

Removal of packaging

Be careful not to damage the unit.

Recycle and dispose of the packaging material in compliance with local regulations.

Before any work read:

⇒ Chapter. MAINTENANCE SAFETY
WARNINGS FOR OPERATIONS ON
UNITS CONTAINING R32

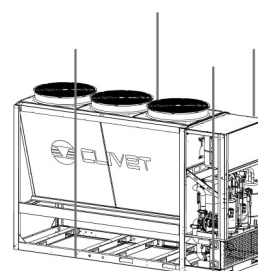
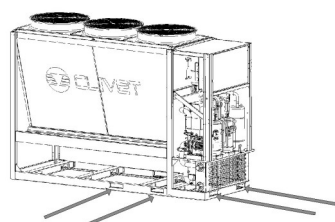

3 HANDLING

- ⇒ Check that all handling equipment complies with local safety regulations (cran, forklifts, ropes, hooks, etc.).
 - ⇒ Provide personnel with personal protective equipment suitable for the situation, such as helmet, gloves, accident-prevention shoes, etc.
 - ⇒ Observe all safety procedures in order to guarantee the safety of the personnel present and the of material.
- A. Verify unit weight and handling equipment lifting capacity.
 - B. Identify critical points during handling (disconnected routes, flights, steps).
 - C. Suitably protect the unit to prevent damage.
 - D. Lifting with balance
 - E. Lifting with spacer bar
 - F. Align the barycenter to the lifting point
 - Gradually bring the lifting belts under tension, making sure they are positioned correctly.
 - Before starting the handling, make sure that the unit is stable.

Do not get on top of the unit

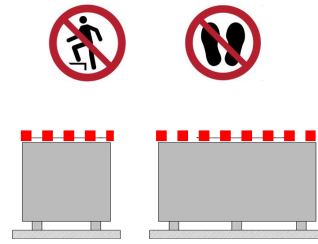

A



B

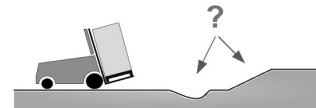

C

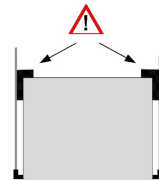

D

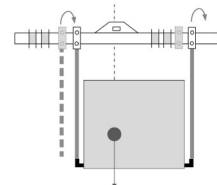
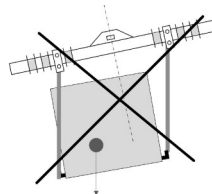
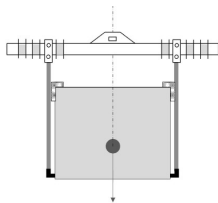

E

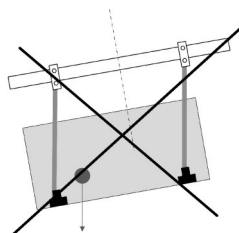
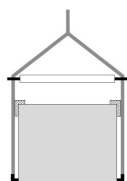

F

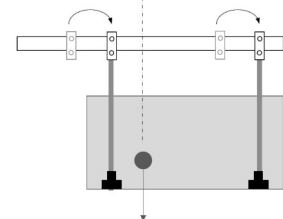

3 SELECTING THE INSTALLATION SITE

Positioning

⇒ Installation must be in accordance with local regulations. If they do not exist, follow EN378.

During positioning consider these elements:

- customer approval
- unit weight and bearing point capacity
- safe accessible position
- functional spaces
- spaces for the air intake/exhaust
- electrical connections
- max. distance allowed by the electrical connections
- water connections

Functional spaces

Functional spaces are designed to:

- guarantee good unit operation
- carry out maintenance operations
- protect authorized operators and exposed people

⇒ Respect all functional spaces indicated in the TECHNICAL INFORMATION section.

Positioning

Units are designed to be installed:

- EXTERNAL
- in fixed positions

⇒ Put the unit in a position where any leaking gas cannot enter buildings or stagnate in closed areas. In the latter case, observe the rules for machinery rooms (ventilation, leak detection, etc.).

Installation standards:

- install the unit raised from the ground
- bearing points aligned and leveled
- discharged condensation water must not cause harm/danger to people and property
- the accumulation of snow must not cause clogging of the coils
- avoid installations in places subject to flooding

Limit vibration transmission:

- use anti-vibration devices or neoprene strips on the unit support points
- install flexible joints on the hydraulic connections

Protect the unit with suitable fence in order to avoid access to unauthorised personnel (children, vandals, etc.)

A correct circulation of the air is mandatory to guarantee the good unit operating..

The unit must be level.

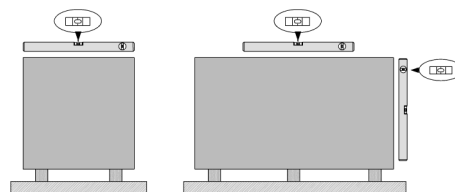

Do not get on the unit

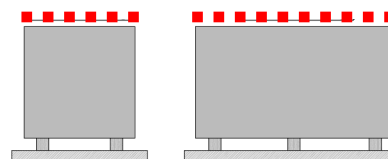

Avoid therefore:

- obstacles to the airflow
- exchange difficulties
- leaves or other foreign bodies that can obstruct the exchange batteries
- winds that hinder or favour the airflow
- heat or pollution sources close to the unit (chimneys, extractors etc)
- stratification (cold air that stagnates at the bottom)
- recirculation (expelled air that is sucked in again)
- positioning below the level of the threshold, close to very high walls, attics or in angles that could give rise to stratification or recirculation phenomenons.

Ignoring the previous indications could:

- energy efficiency decrease
- alarm lockout due to HIGH PRESSURE (in summer) or LOW PRESSURE (in winter)

Pressure relief valve gas side

The installer is responsible for evaluating the opportunity of installing drain pipes in compliance with the local regulations in force (EN 378).

If ducted, the valves must be sized according to EN13136 .

Functional spaces Safety Zone

Do not smoke or use open flames within this area

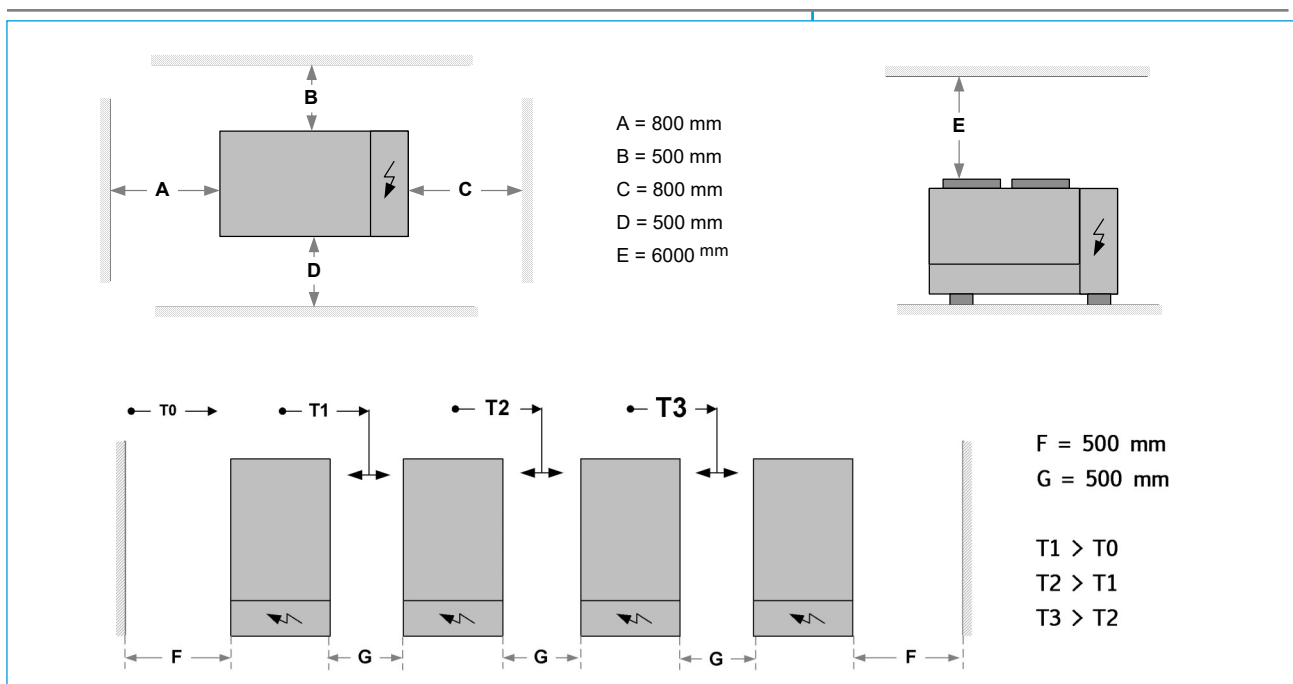

Anti-vibration mounts

Option

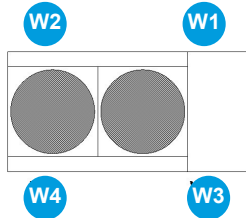
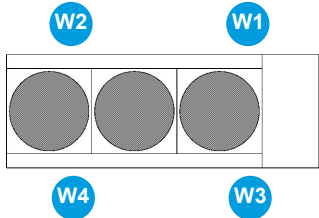
Size	18.2 - 20.2		25.2 - 35.2	
support points				
Configuration	standard	with storage tank	standard	with storage tank
KIT PE	PESM00003	PESM00004	PEST00003	PEST00004
W1 (code)	PAF 11 SPEC	PAF 13 SPEC	PAF 14 SPEC	PAF 22 SPEC
W2	PAF 11 SPEC	PAF 13 SPEC	PAF 90 SPEC	PAF 12 SPEC
W3	PAF 11 SPEC	PAF 13 SPEC	PAF 90 SPEC	PAF 12 SPEC
W4	PAF 11 SPEC	PAF 13 SPEC	PAF 14 SPEC	PAF 22 SPEC

Protection grilles Option

PESM00007

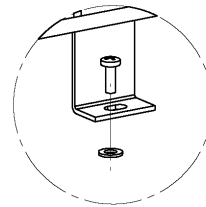
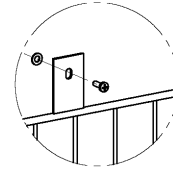
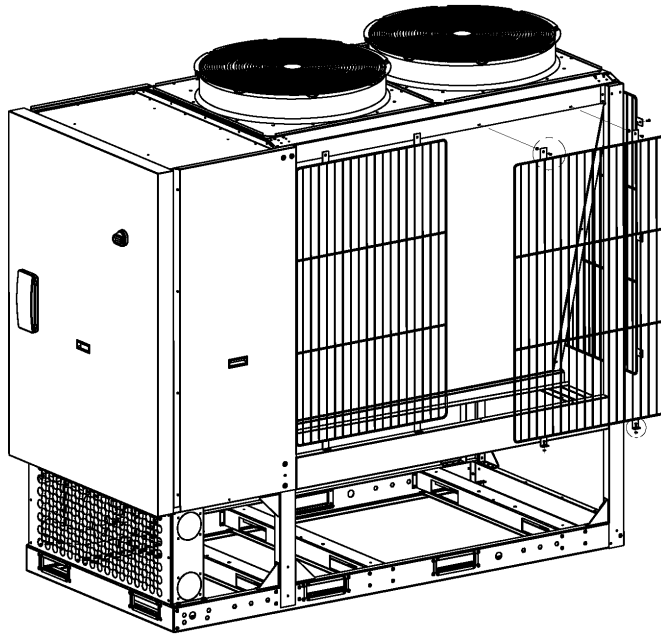

PESM00008

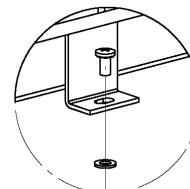
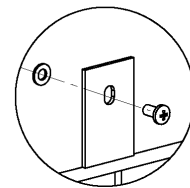
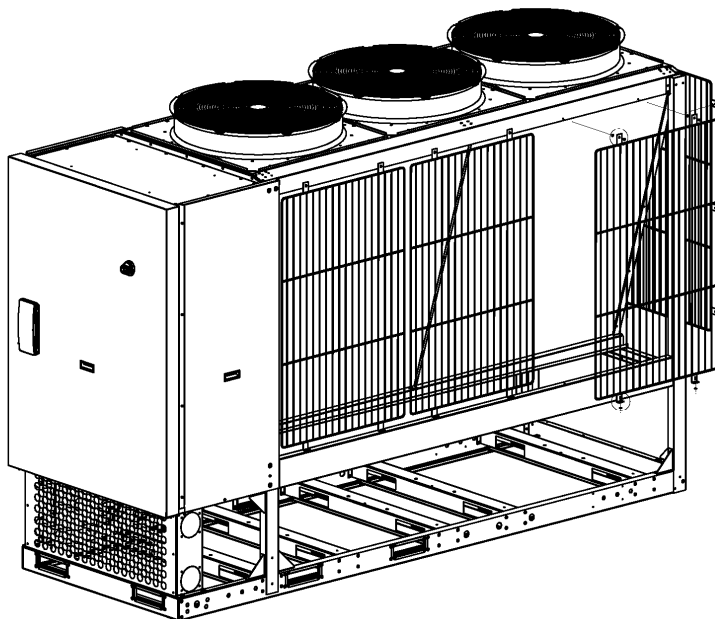

5 WATER CONNECTION

Hydraulic system

The pipes must be designed and manufactured to limit pressure drops as much as possible, i.e. optimise performance of the system. Keep the following to a minimum:

- overall length
- number of bends
- number of vertical changes of direction

If the unit is to replace an existing unit, clean the system thoroughly: see Sequence of operations on the following pages

Water quality

The water quality can be checked by qualified personnel.

Water with inadequate characteristics can cause:

- pressure drop increase
- energy efficiency decrease
- corrosive symptom increase

Water features:

- within the limits indicated by table

Provide a water treatment system if values fall outside the limits.

Cleanliness

Before connecting the water to the unit, clean the system thoroughly with specific products effective to remove residues or impurities that may affect functioning. Existing systems must be free from sludge and contaminants and protected against build-ups.

New systems

In case of new installations, it is essential to wash the entire installation (with the circulator uninstalled) before commissioning the central installation. This removes residues of the installation process (welding, waste, joint products...). The system must then be filled with clean high-quality tap water.

Existing systems

If a new unit is installed on an existing system, the system must be rinsed to avoid the presence of particles, sludge and waste. The system must be drained before installing the new unit. Dirt can be removed only with a suitable water flow. Each section must then be washed separately. Particular attention must also be paid to "blind spots" where a lot of dirt can accumulate due to the reduced water flow. The system must then be filled with clean high-quality tap water. If, after rinsing, the quality of the water is still unsuitable, a few measures must be taken to avoid problems. An option to remove pollutants is to install a filter.

The warranty does not cover damages caused by limestone formations, deposits and impurities from the water supply and/or from failure to clean the systems.

Water component for corrosion limit on Copper

PH	7,5 ÷ 9,0	
SO ₄ ²⁻	< 100	
HCO ₃ ⁻ / SO ₄ ²⁻	> 1	
Total Hardness	8 ÷ 15	°f
Cl ⁻	< 50	ppm
PO ₄ ³⁻	< 2,0	ppm
NH ₃	< 0,5	ppm
Free Chlorine	< 0,5	ppm
Fe ₃ ⁺	< 0,5	ppm
Mn ²⁺	< 0,05	ppm
CO ₂	< 50	ppm
H ₂ S	< 50	ppb
Temperature	< 65	°C
Oxygen content	< 0,1	ppm
Sand	10 mg/L 0.1 to 0.7mm max diameter	
Ferrite hydroxide Fe ₃ O ₄ (black)	Dose < 7.5 mg/L 50% of mass with diameter < 10 µm	
Iron oxide Fe ₂ O ₃ (red)	Dose < 7.5mg/L Diameter < 1 µm	

Water flow-rate

The design water flow-rate must be:

- inside the exchanger operating limits
- guaranteed also with variable system conditions (for example, in systems where some circuits are bypassed in particular situations)

If the system capacity is below the minimum flow, bypass the system as indicated in the diagram.

If the system capacity exceeds the maximum flow, bypass the system as indicated in the diagram

Admissible water flow-rate

Minimum (Q_{min}) and maximum (Q_{max}) admissible water flow for the unit to operate correctly.

Minimum water flow

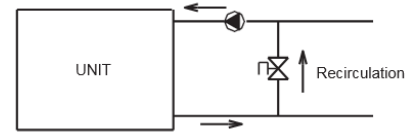

Maximum water flow

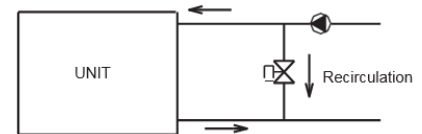

SIZE		18.2	20.2	25.2	30.2	35.2
Minimum flow-rate	[l/s]	1,9	1,9	2,9	2,9	2,9
Maximum flow-rate	[l/s]	6,4	6,4	6,4	6,4	6,4

Risk of freeze

If the unit or the relative water connections can be subject to temperatures close to 0°C:

- Mix water with ethylene glycol, or
- Safeguard the pipes with heating cables placed under the insulation, or
- Empty the system in cases of long non-use

Anti-freeze solutions

Consider that the use of anti-freeze solution determines an increase in a pressure drop.

Make sure that the glycol type utilized is inhibited (not corrosive) and compatible with the hydraulic circuit components.

Do not use different glicol mixture (i.e. ethylic with propylene).

The unit must always be protected from freeze. Otherwise irreversible damage may occur.

% ETHYLENE GLYCOL BY WEIGHT		5%	10%	15%	20%	25%	30%	35%	40%	45%	50%
Freezing temperature	°C	-2	-3.9	-6.5	-8.9	-11.8	-15.6	-19.0	-23.4	-27.8	-32.7
Safety temperature	°C	3	1	-1	-4	-6	-10	-14	-19	-23.8	-29.4

Water filter

⇒ Must be installed immediately in the water input of the unit, in a position that is easily accessible for cleaning.

⇒ The filter never should be removed, this operation invalidates the guaranty.

Recommended filter :

0,5 mm (30 mesh)



User side connection

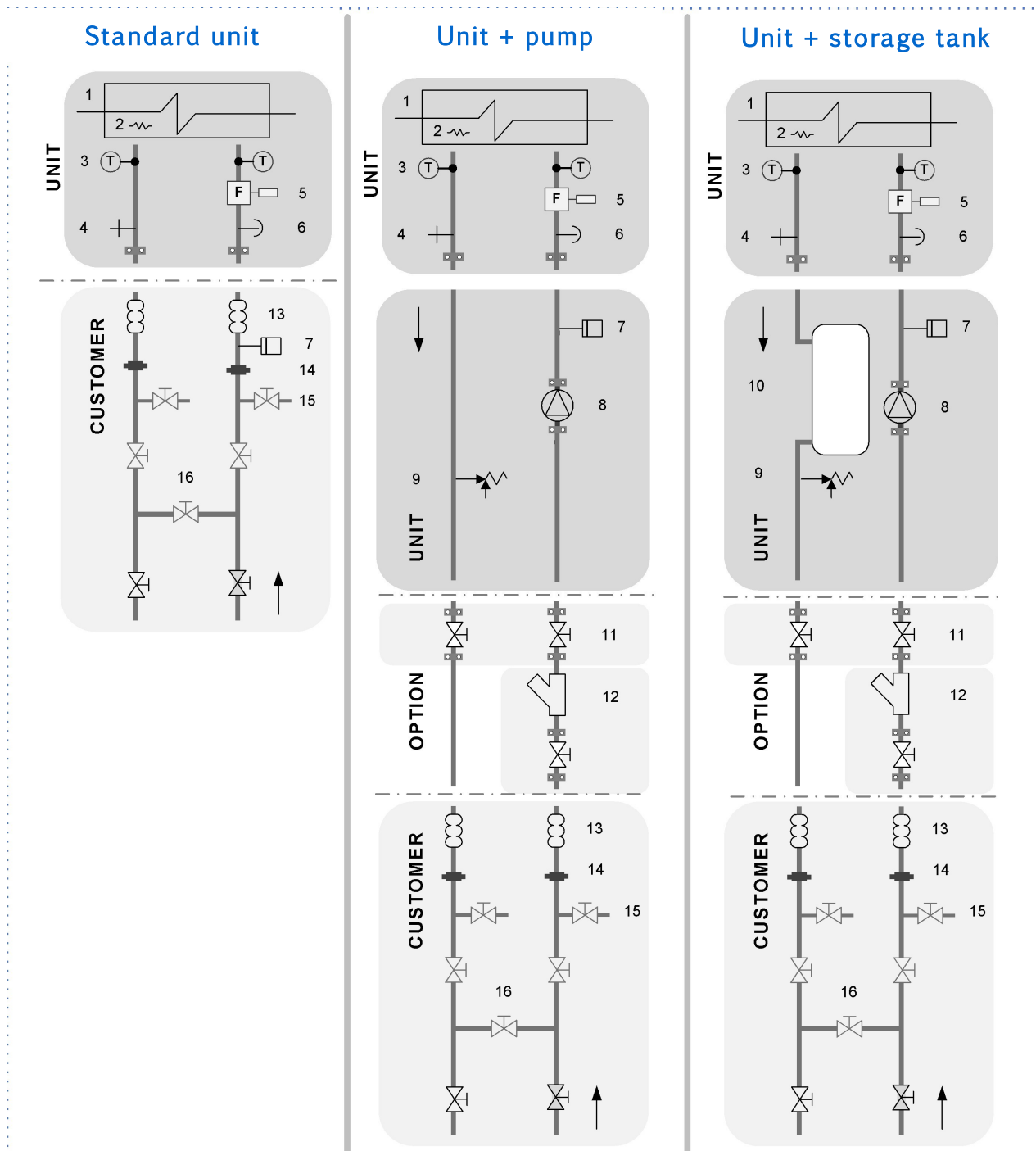

- 1 exchanger
- 2 antifreeze heater
- 3 water temperature probe
- 4 drain
- 5 water flow switch
- 6 vent
- 7 system loading safety pressure switch
- 8 pump

- 9 pressure relief valve
- 10 storage tank
- 11 shut-off valves
- 12 filter
- 13 flexible couplings
- 14 piping supports
- 15 exchanger chemical cleaning bypass
- 16 system cleaning bypass

TW Probe - Total water

It must be installed on the supply of the unit, as far away as possible.

SINGLE UNIT: antifreeze function

MODULAR UNIT: thermoregulation (see diagram below)

Water connections

Standard: Victaulic type

Option: to weld

Operations sequence

Before starting the unit pump:

- 1 Close all vents in the high points of the unit's water circuit.
 - 2 Close all drain shut-off valves in the low points of the unit's water circuit
 - Exchangers
 - Pumps
 - collectors
 - storage tanks
 - 3 Thoroughly wash the system with clean water:
use the bypass to exclude the exchanger from the flow (diagram on previous page) fill and drain the system several times.
 - 4 Apply additives to prevent corrosion, fouling, formation of mud and algae.
 - 5 Fill the system
do not use the unit pump
 - 6 Conduct a leak test.
 - 7 Isolate the pipes to avoid heat dispersions and formation of condensate.
 - 8 Leave various service points free (wells, vents, etc).
- ⇒ *Neglecting to wash will lead to the filter having to be cleaned many times and at worst may damage the exchangers and compressors.*

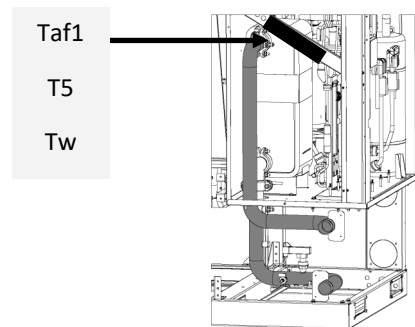

Victaulic

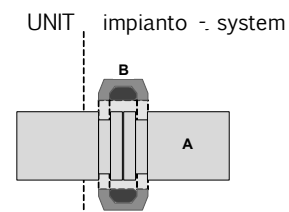

A+B: fornito da Clivet - Clivet supplied

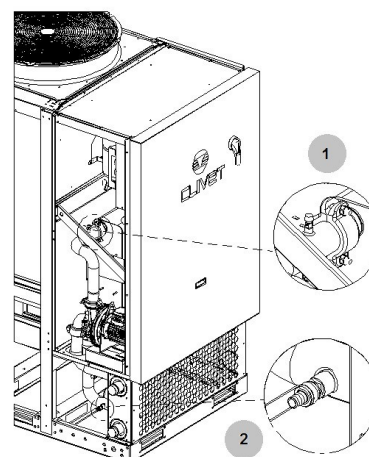
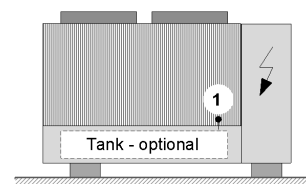

Unit in modular configuration

- Maximum 16 total units.
- Maximum 4 units in the same water branch.
- The modular system is controlled by the MASTER unit (address=0), → *Electrical connections*
- All units must be electrically connected to each other con cavo schermato a 3 conduttori → *Electrical connections* Each module must be configured with the water fittings for modular unit (AMOD).
- Each module can be equipped with inertial system storage tank (ACIMP).
- It is necessary to provide an external pumping unit, sized for the entire capacity of the modular system (responsibility of the Customer). The pumping unit will be managed by the Master unit through a potential-free contact and 0-10V signal → *electrical connections*

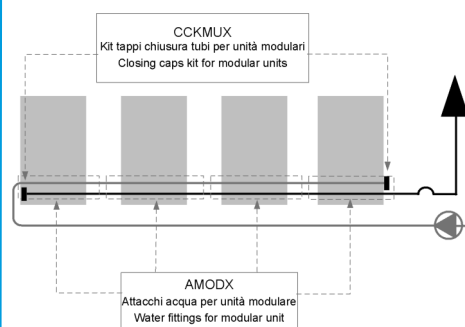

	Option	Code
CCKMUX	Kit containing pipe closing caps for modular units	PESM00001
AMODX	Water fittings for modular unit	PEST00001

1

2

3

4

Spacers Option

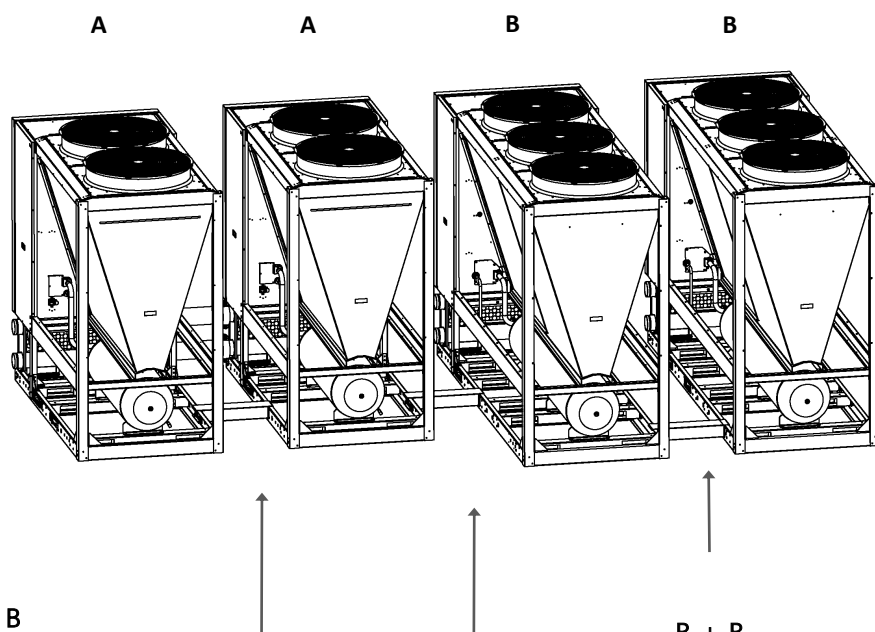

A + A , A + B

Togliere le cornici di protezione gialle per il sollevamento e usare i 4 fori per fissare il distanziale

Remove yellow lift frame and use holes to fix spacer

B + B

Usare i 4 fori predisposti per fissare il distanziale

Use prepared holes to fix spacer

6 ELECTRICAL CONNECTIONS

The characteristics of the electrical lines must be determined by specialized personnel able to design electrical installations; moreover, the lines must be in conformity with regulations in force.

The protection devices of the unit power line must be able to stop the presumed short circuit current, whose value must be determined in function of system features.

The power cables and the protection cable section must be defined in accordance with the characteristics of the protections adopted.

All electrical operations should be performed by trained personnel having the necessary requirements by the regulations in force and being informed about the risks relevant to these activities.

Operate in compliance with safety regulations in force.

Electrical data

The serial number label reports the unit specific electrical data, included any electrical accessories.

The electrical data indicated in the technical bulletin and in the manual refer to the standard unit, accessories excluded.

Refer to the electrical data report on the serial number label:

- Tensione
- F.L.A.: full load ampere, absorbed current at maximum admitted conditions
- F.L.I.: full load input, full load power input at max. admissible condition
- Electrical wiring diagram Nr

Connections

refer to the unit electrical diagram (the number of the diagram is shown on the serial number label).

verify that the network has characteristics conforming to the data shown on the serial number label.

Before starting work, verify that the sectioning device at the start of the unit power line is open, blocked and equipped with cartel warning.

Primarily you have to realize the earthing connection.

Shelter the cables using adequate measure fairleads.

Before power the unit, make sure that all the protections that were removed during the electrical connection work have been restored.

Signals / data lines

Do not overpass the maximum power allowed, which varies, according to the type of signal.

Lay the cables far from power cables or cables having a different tension and that are able to emit electromagnetic disturbances.

Do not lay the cable near devices which can generate electromagnetic interferences.

Do not lay the cables parallel to other cables; cable crossings are possible, only if laid at 90°.

Connect the screen to the ground, only if there aren't disturbances.

Guarantee the continuity of the screen during the entire extension of the cable.

Respect impedance, capacity and attenuation indications.

Power input

Fix the cables: if vacated may be subject to tearing.

The cable must not touch the compressor and the refrigerant piping (they reach high temperatures).

Remote ON-OFF

Do not perform short On Off cycles

Do not use the remote On Off with thermoregulation function.

Isolating switch

Option

Mounted on board or for remote installation.

I = 67 A / A C23 cable guides M40

Remote ON-OFF

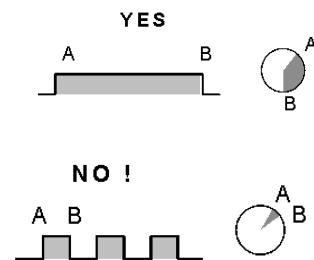

Connections performed by customer

KM1	Relè di comando resistenza ausiliaria tubatura acqua Control relay for auxiliary water storage tank auxiliary heater Relais pour commande de résistance auxiliaire au collecteur d'eau de sortie Relais für Wasserdruck-Mittelkreisheizkörper Relé para control de resistencia auxiliar de tubería de agua	TEMP SW	Selettore remoto per cambio set-point Remote set-point selector Fernwählbarer Setpunkt Sélecteur déporté pour changement de consigne Selector remote para cambio set-point	---	---
KM2	Relè di comando resistenza ausiliaria accumulato acqua sanitaria Control relay for auxiliary water storage tank auxiliary heater Relais pour relais de contrôle de réservoir d'eau sanitaire Relais für Wasserdruckspeicher-Ausweise Relé para el control de control del tanque de almacenamiento de agua	ALM	Segnalazione blocco cumulativo Cumulative fault signal Summierungsfeld Cumulación de error Sedláčenie blokov kumulatívno	---	410_2 Pg. 15.2
HL1	Lampada di segnalazione stato compressore Compressor status signal lamp Signalampe Ventilatorlampe Lampara de señalización estado compresor	SPA2	Pressostato controllo carico impianto System charge control pressure switch Druckschalter für die Systemfüllung Presostato de control de carga de sistema Presostato de control de carga del sistema	---	---
KMU	Comatore di comando pompa a carico cliente Pump control selector provided by the customer Kundenbezogener Schalter/ Pumpensteuerung Conducteur commande pompe à la charge du client Conductor de accionamiento bomba a cargo del cliente	ON/OFF	Selettore ON/OFF remoto Remote ON/OFF selector Fernwählbarer Ein/Aus Sélecteur ON/OFF déporté Selector ON/OFF remoto	---	---
TW	Sonda di temperatura totale al collettore dell'acqua in uscita Total outlet water temp Sonde de température totale au collecteur d'eau de sortie Totalempertemperaturfühler Sonda de temperatura de almacenamiento de ACS	T5	Sonda di temperatura accumulata acqua calda sanitaria Sanitary hot water temperature probe Wärmespeicher-Temperaturfühler Sonda de temperatura de storage ECS Sonda de temperatura de almacenamiento de ACS	AMOD 170_31 Pg. 15.12	VACS 466_10 Pg. 15.2
Taf1	Sensore antigelo su acqua lato ACS Anti-freeze sensor on water on BWH side Optique antigel sur l'eau de côté de l'acs Insera la pinnola frigidizzatore on water nel del acc-selle Sensor anticongelante en agua en el lado acs				

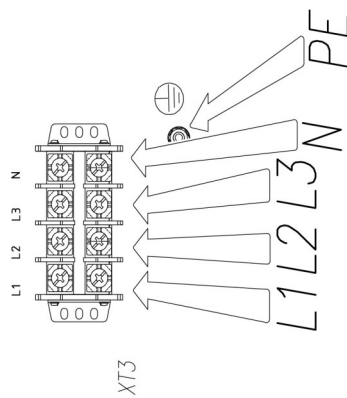

*collegamenti a cura del cliente
connections performed by customer
raccordements à la charge du client
Kundenseitige Anschlüsse
conexiones a cargo del cliente*

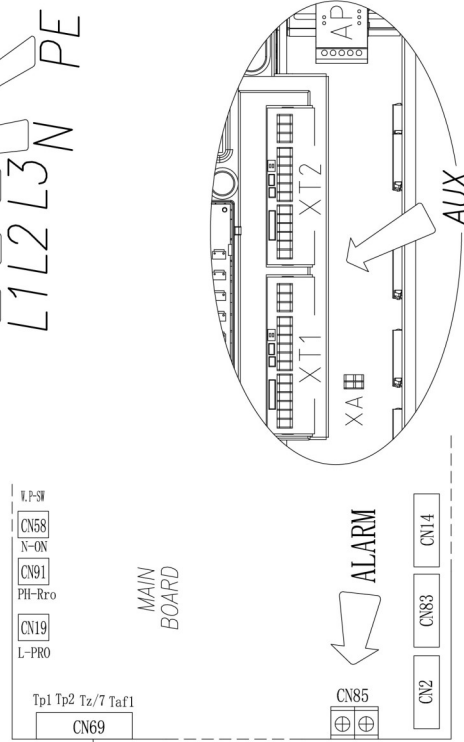

Taf1

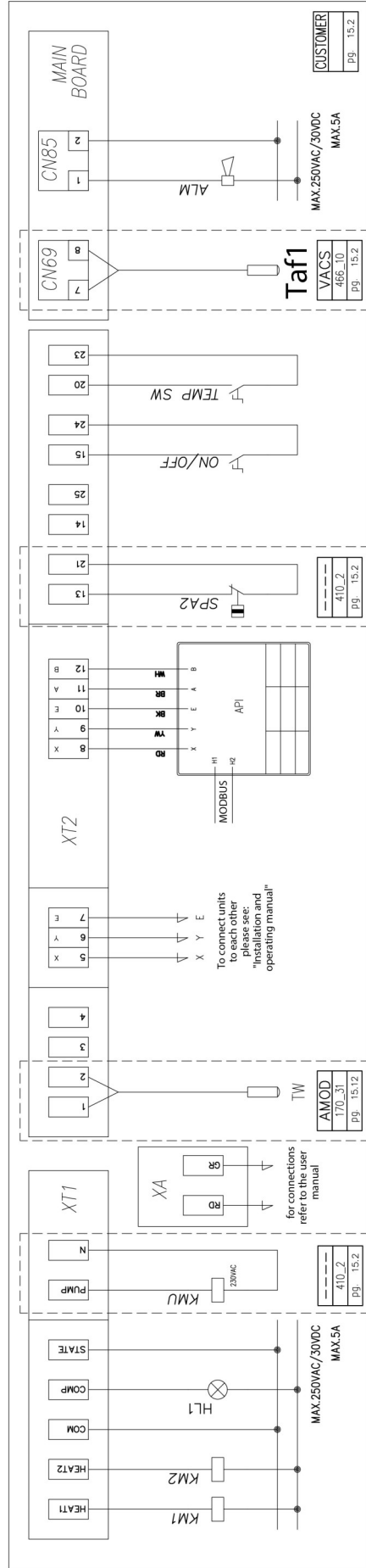

Remote control of the unit

With S5_3 ON, the unit is controlled remotely.

Wired controller disabled.

ON/OFF state:

controlled by the On/Off input

input ON = unit ON

With the units in modular configuration, remote control must be applied to the master unit, which transmits it to the slave units.

After having set S5_3 disconnect and reconnect the power supply to confirm the change.

Unit in modular configuration

Set the correct date and time on each unit before connecting them to the network

Enable multiple configuration:

SW12-2 :

- ON units in multiple configuration
- OFF single unit

The modular configuration consists of two networks: the controller network and the unit network (main boards).

Each network can have up to 16 addresses (from 0 to 15) and must be addressed separately.

Each network has its own master, which must have address = 0.

Modular configuration - Addressing units

They are addressed through the encoder ENC4 on the back of the keypad.

The address corresponds to the encoder no.

The address is shown on the display DSP1.

Es: MASTER : address = 0 encoder = 0

SLAVE 1 : address = 1 encoder = 1

SLAVE 15 : address = 15 encoder = F

Modular configuration - Addressing controls

A maximum of 16 controls can be addressed, with address from 0 to 15; so for example:

16 units with relative controller on board, one of which is the master

15 units with relative controller on board + a remote controller as the master

Press MENU + ► for 3 seconds

Press ▲▼ to select the address

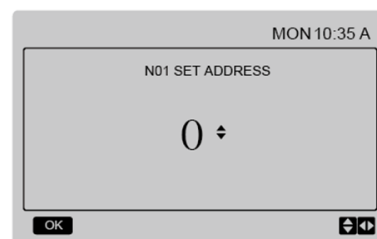
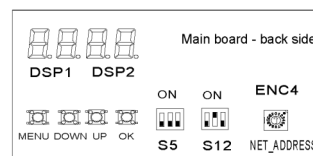
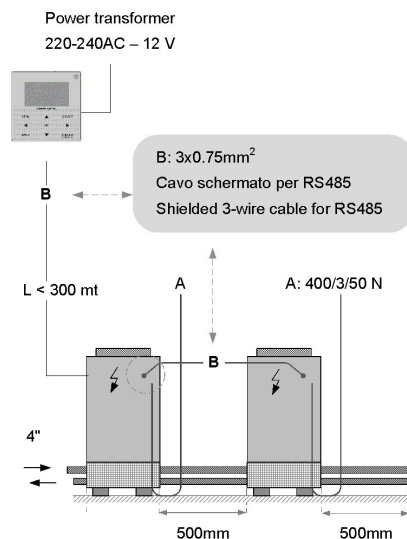
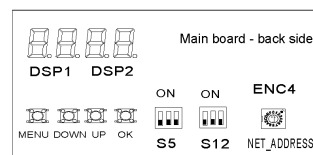

Modular configuration - Controller wiring

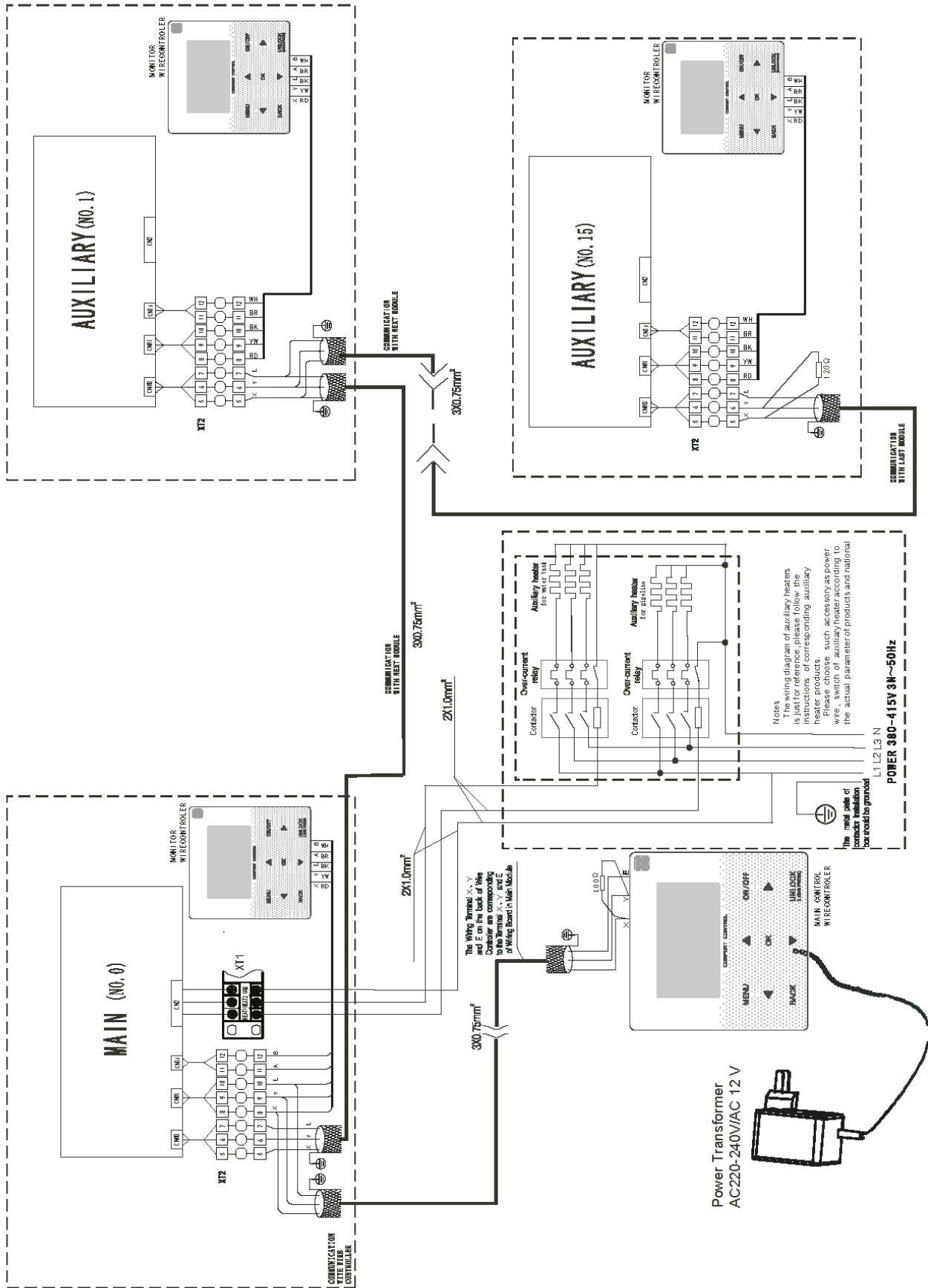

MODBUS

The modbus in reading is always enabled.

It is possible to read 1 register at a time.

To enable it for writing:

set register 138 to 1, or

set on the controller

Project Menu → Controller select → Modbus = Yes

Communication spec: RS-485

Protocol :ModbusRTU: 9600,8,N,1

Baud rate : 9600bps

Data bits: 8 Data bits

Parity bit: None Parity

Stop bit: 1 stop bit

Connections

Connect on the back of the controller.

Modular unit: connect the modbus to the MASTER unit port .

Unit address

The default address is 1.

It can be modified on the controller:

Project Menu → Controller select → Modbus address

Function code

03	reading
06	single register writing
16	multiple register writing

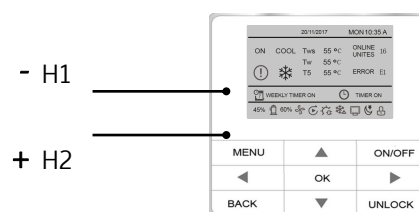

Reading register, writing a single register, multiple register writing

Address	function	note
0	Modo	(1 Cooling, 8 Off)
1	Temperature Setpoint	COOL (5°C ~ 20°C)
2	Temperature Setpoint B	COOL(5°C ~ 20°C)

Reading and writing register

Address	function	note
101	Double setpoint	Enable/Disable 1/0
102	1o setpoint in cooling	5~20°C
103	2o setpoint in cooling	5~20°C
106	temperature compensation in cooling	Enable/Disable
107	point 1 temperature compensation in cooling	25~30°C
108	point 2 temperature compensation in cooling	35~40°C
109	temperature compensation value in cooling	0~15°C
138	Modbus writing enable disable local control from controller	1 = enabled; 0 = disabled

Addresses 0 - 15 are the addresses of the selected units.

(addresses)*100+240—(addresses)*100+299 , are read only.

Unit in modular configuration

Reading register		
Adress	function	note
240+(Address)*100	Running mode	1 shutdown , 2 cooling
241+(Address)*100	SILENT mode	1 Standard, 2 Silent, 3 Super silent
242+(Address)*100	Setpoint	1°C
243+(Address)*100	Setpoint B	1°C
244+(Address)*100	Unit inlet water temperature Twi	1°C
245+(Address)*100	Unit outlet water temperature Two	1°C
246+(Address)*100	Total outlet water temperature Tw	1 ² ; only for the master (0)
247+(Address)*100	Outdoor temperature - T4	1°C
248+(Address)*100	Compressor speed	1Hz
249+(Address)*100	Compressor 1 absorption	1A
250+(Address)*100	Fan 1 speed	Current speed
251+(Address)*100	Fan 2 speed	Current speed
252+(Address)*100	Fan 3 speed	Current speed
253+(Address)*100	EXV	Current position
255+(Address)*100	EXVC	Current position
256+(Address)*100	SV4	0 Off, 1 On
257+(Address)*100	SV5	0 Off, 1 On
258+(Address)*100	SV8A	0 Off, 1 On
259+(Address)*100	SV8B	0 Off, 1 On
260+(Address)*100	4-way valve	0 Off, 1 On
261+(Address)*100	circulation pump	0 Off, 1 On
262+(Address)*100	SV1	0 Off, 1 On
263+(Address)*100	SV2	0 Off, 1 On
266+(Address)*100	compressor 1 discharge temperature - Tp1	1°C
267+(Address)*100	intake temperature - Th	1°C
268+(Address)*100	coil temperature - T3	1°C
269+(Address)*100	temperature of liquid line (in cooling mode) - Tz	1°C
270+(Address)*100	DHW storage temperature - T5	1°C
271+(Address)*100	P PRESSURE	10 kPa
272+(Address)*100	error / protection	see error codes table
273+(Address)*100	last error / protection	see error codes table
274+(Address)*100	software version	HMI
275+(Address)*100	compressor 2 discharge temperature - Tp2	1°C
276+(Address)*100	not used	
277+(Address)*100	economiser inlet temperature - T6a	1°C
278+(Address)*100	wired control error	
279+(Address)*100	SV6	0 Off, 1 On
280+(Address)*100	Compressor 2 absorption	1A

Status query register		
Register Address	Dati	Note
0	Compressor status	
1	Fan status	
2	Pump status	
3	reserved	
4	reserved	
5	SV1	
6	SV2	
7	reserved	
8	Defrosting	
9	Antifreeze electric heater	
10	Remote control	
11	SILENT mode	Standard, silent, super silent
12	reserved	
13	Alarm signals	
14	Unit group status	1: modular unit 0: single unit

When the BMS reading, register 272, 273 displays one of the following “error codes” in decimal format, only considering the BYTE LOW.

Only consider the last two alphanumeric digits of the code.

Fault Code	E0	E1	E2	E3	E4	E5	E6	E7	E8	E9	EA	Eb	EC	Ed	EE
Fault Number (dec)	1	2	3	4	5	6	7	8	9	10	11	12	13	14	15
Fault Code	EF	EH	EL	EP	EU	P0	P1	P2	P3	P4	P5	P6	P7	P8	P9
Fault Number (dec)	16	17	18	19	20	21	22	23	24	25	26	27	28	29	30
Fault Code	PA	Pb	PC	Pd	PE	PF	PH	PL	PP	PU	H0	H1	H2	H3	H4
Fault Number (dec)	31	32	33	34	35	36	37	38	39	40	41	42	43	44	45
Fault Code	H5	H6	H7	H8	H9	HA	Hb	HC	Hd	HE	HF	HH	HL	HP	HU
Fault Number (dec)	46	47	48	49	50	51	52	53	54	55	56	57	58	59	60
Fault Code	F0	F1	F2	F3	F4	F5	F6	F7	F8	F9	FA	Fb	Fc	Fd	FE
Fault Number (dec)	61	62	63	64	65	66	67	68	69	70	71	72	73	74	75
Fault Code	FF	FH	FL	FP	FU	C0	C1	C2	C3	C4	C5	C6	C7	C8	C9
Fault Number (dec)	76	77	78	79	80	81	82	83	84	85	86	87	88	89	90
Fault Code	CA	Cb	CC	Cd	CE	CF	CH	CL	CP	CU	L0	L1	L2	L3	L4
Fault Number (dec)	91	92	93	94	95	96	97	98	99	100	101	102	103	104	105
Fault Code	L5	L6	L7	L8	L9	LA	Lb	LC	Ld	LE	LF	LH	LL	LP	LU
Fault Number (dec)	106	107	108	109	110	111	112	113	114	115	116	117	118	119	120
Fault Code	d0	d1	d2	d3	d4	d5	d6	d7	d8	d9	dA	db	dC	dd	dE
Fault Number (dec)	131	132	133	134	135	136	137	138	139	140	141	142	143	144	145
Fault Code	dF	dH	dL	dP	dU										
Fault Number (dec)	146	147	148	149	150										

7 START-UP

General

The electrical, water connections and the other system works are by the installer.

Agree upon in advance the start-up data with the service centre.

Agree upon in advance the star-up data with the service centre.

For details, refer to the various chapters in the manual.

Before checking, please verify the following:

- the unit should be installed properly and in conformity with this manual
- the electrical power supply line should be sectioned at the beginning.
- The line sectionalizing device is open, locked and equipped with the suitable warning
- make sure no tension is present

WARNING

⇒ *After turning off the power, wait at least 10 minutes before accessing to the electrical panel or any other electrical component.*

⇒ *Before accessing check with a multimeter that there are no residual stresses*

⇒ *Do not power the unit with empty water side exchangers. Possible damage to anti-freeze electric heaters.*

Preliminary checks

Unit OFF power supply

		Yes / No
1	safe access	
2	suitable frame to withstand unit weight + people weight	
3	functional clearances	
4	air flow: correct return and supply (no bypass, no stratification)	
5	considered level to be reachable by snow	
6	considered main winds	
7	lack of chimneys/corrosive atmospheres/pollutants	
8	structure integrity	
9	fans run freely	
10	unit on vibration isolators	
11	The unit must be level.	
12	unit input water filter + shut-off valves for cleaning	
13	vibration dampeners on hydraulic connections	
14	expansion tank (recommended volume = 10% system content)	
15	minimum system water content	
16	clean system	
17	loaded system + possible glycol solution + corrosion inhibitor	
18	system under pressure + vented	
19	refrigerant circuit visual check	
20	earthing connection	
21	power supply features	
22	remote On-Off	

Start-up sequence

Unit power supply ON



Before powering the unit carry out a leak test with suitable instrumentation

		Yes / No
1	compressor carter resistances operating at least since 8 hours	
2	off-load voltage measure	
3	phase sequence check	
4	pump manual start-up and flow check	
5	refrigeration circuit shut-off valves opening (if applicable)	
6	unit ON	
7	load voltage measure	
8	verify the lack of bubbles in the liquid light (if applicable)	
9	check of all fan operating	
10	measure of return and supply water temperature	
11	super-heating and sub-cooling measure	
12	check no anomalous vibrations are present	
13	set-point personalization	
14	scheduling customisation	
15	complete and available unit documentation	

Cooling circuit

- 1 Visually inspect the refrigerating circuit: the presence of oil stains can be a symptom of leakage (caused e.g. by transportation, handling or other).
- 2 Verify that the refrigerating circuit is in pressure: Using the unit manometers, if present, or service manometers.
- 3 Make sure that all the service outlets are closed with proper caps; if caps are not present a leak of refrigerant can be possible.
- 4 Open all of the refrigeration circuit shut-off valves (if applicable).

Hydraulic circuit

- 1 Before connecting the unit to the hydraulic system, make sure that the hydraulic system has been washed and that the water has been drained
- 2 Check that the hydraulic circuit has been filled and pressurized-
- 3 Check that the shut-off valves in the circuit are in the "OPEN" position.
- 4 Check that there is no air inside the circuit, and bleed it through the vent valves in the high points of the system if necessary.
- 5 When using antifreeze solutions, make sure the glycol percentage is suitable for the type of use envisaged.

NOTE

⇒ *Neglecting the washing will lead to several filter cleaning interventions and at worst cases can cause damages to the exchangers and the other parts.*

Electric circuit

Check the unit is connected to the earthing system.

Check the conductors are tightened as: the vibrations caused by handling and transport might cause these to come loose.

Power the unit by closing the isolation device but leave in OFF.

Check the network frequency and voltage values, which must be within the limits: 400-3-50 +/-10%

Check and adjust the phase balance as necessary: it must be lower than 2%

NOTE

⇒ *Working outside of these limits can cause irreversible damages and voids the warranty.*

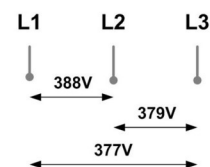

$$1) \frac{388 + 379 + 377}{3} = 381 \text{ (A)}$$

$$2) \text{MAX} - A = 388 - 381 = 7$$

$$3) S = \frac{7}{A} \times 100 = 1,83 \text{ OK}$$

Compressor casing resistances

Connect the compressor oil heating resistances at least 8 hours before the compressor is to be started:

- at the first unit start-up
 - after each prolonged period of inactivity
- 1 Power the heaters.
 - 2 Check the power consumption of the resistances to make sure that they are functioning.
 - 3 Start-up the compressor only if the crank-case temperature on the lower side is higher than the outside temperature by at least 10°C .
 - 4 Do not start the compressor with the crankcase oil below operating temperature.

Voltage

Check that the air and water temperatures are within in the operating limits.

Start-up the unit.

While the unit is operative, i.e. in stable conditions nearing operating ones, check:

- Power supply voltage
- Total absorption of the unit
- Absorption of the single electric loads

Remote controls

Check that the remote controls (ON-OFF etc) are connected and, if necessary, enabled with the respective parameters as indicated in the “electrical connections” section.

Check that probes and optional components are connected and enabled with the respective parameters (“electrical connections” section and following pages).

Pump manual start

To be done only during the course of the first start-up, for flow switch/differential pressure switch test.

To start the pump, connect as in fig. 2.

At the end of the test, restore the connection as in fig. 1.

Scroll compressor

Scroll compressors have only one rotation direction.

In the event it is reversed, the compressor is not immediately damaged, but increases its noise and jeopardises pumping.

After a few minutes the compressor shuts down due to the thermal protection tripping.

In this case, disconnect the power supply and invert 2 phases on the machine power supply.

Do not let the compressor work for a long time with opposite rotation: more than 2-3 of these abnormal start-ups can damage it.

To ensure the rotation direction is correct, measure the condensation and suction pressure.

The pressures must significantly differ: upon start-up, the suction pressure decreases while the condensation one increases.

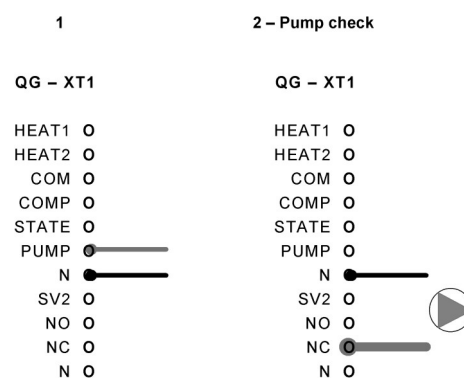

Check evaporator water flow rate

Check that the difference between the temperature of exchanger return and supply water corresponds to power according to this formula:

unit cooling power (kW) x 860 = Dt (°C) x flow rate (L/h).

The cooling power is shown in the table of the GENERAL TECHNICAL DATA included in this manual, referred to specific conditions, or in the tables on cooling

PERFORMANCE in the TECHNICAL BULLETIN referred to various conditions of use.

Check for water side exchanger pressure drops:

- Determine the water flow rate.
- Measure the difference in pressure between exchanger input and output and compare it with the graph on WATER SIDE EXCHANGER PRESSURE DROPS

The measurement of pressure will be easier if pressure gauges are installed as indicated in the DIAGRAM OF SUGGESTED WATER CONNECTIONS.

UNITS IN MULTIPLE CONFIGURATION

Complete system management is carried out by the master unit, identified by address 0.

Thermoregulation takes place on the supply temperature of the entire system (Tw).

At switch-on, when a load is requested, the units are switched on in sequence based on their address, in numerical order.

When the load decreases, the units are switched off following the same sequence.

Example in heating

each unit turns on if:

$$T_w \geq (\text{setpoint} + T_{w_diff} + 1^\circ\text{C})$$

each unit turns off if:

$$T_w \leq (\text{setpoint} - 1^\circ\text{C})$$

At power on, If $T_w \geq \text{set point} + 10^\circ\text{C}$

⇒ the control activates 50% of the resources in sequence based on the set address.

⇒ after a time interval (default: 240 seconds)

⇒ if the load increases, additional resources are activated

⇒ if the load decreases, the units are switched off following the same sequence (*first start, first stop*).

If $T_w < \text{set point} + 10^\circ\text{C}$

⇒ the control activates only the master unit.

⇒ after a time interval (default: 240 seconds)

⇒ if the load increases, additional resources are activated based on the set address

⇒ if the *load decreases, the master unit switches off*.

Reduced load operation

The units are equipped with partialisation steps and so can operate with reduced loads.

However, a constant and long operation with reduced load with frequent compressor(s) stops and start-ups can cause irreparable damages for the absence of oil return.

⇒ *The above-described operating conditions must be considered outside the operating limits.*

⇒ *If the compressor breaks down due to operating in the above-mentioned conditions, the warranty shall no longer be valid and CLIVET spa shall not accept any liability.*

Periodically check the average operating times and frequency of compressor start-ups: indicatively the minimum thermal load must be such as to require a compressor to operate for at least ten minutes.

If the average times are close to this limit, take the proper corrective actions.

Start-up report

To detect the objective operational conditions is useful to control the unit over time.

With unit at steady state, i.e. in stable and close-to-work conditions, identify the following data:

- total voltages and absorptions with unit at full load
- absorptions of the different electric loads (compressors, fans, pumps etc)
- temperatures and flows of the different fluids (water, air) both in input and in output from the unit
- temperatures and pressures in the feature points of the cooling circuit (compressor, liquid, suction drain/unload)

The detections must be kept and made available during maintenance interventions.

Directive 2014/68EU PED

Directive 2014/68EU PED also sets out the regulations for unit installers, users and maintenance operators.

Refer to local regulations; briefly and as an example, see the following:

Compulsory verification of the first installation:

- only for units assembled on the installer's building site (for ex. condensing circuit + direct expansion unit)

Commissioning declaration:

- for all units

Periodical checks:

- to be executed with the frequency indicated by the Manufacturer (see the "maintenance inspections" paragraph)

8 CONTROL

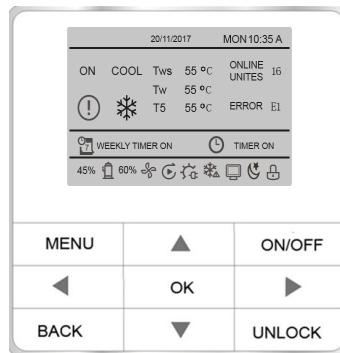







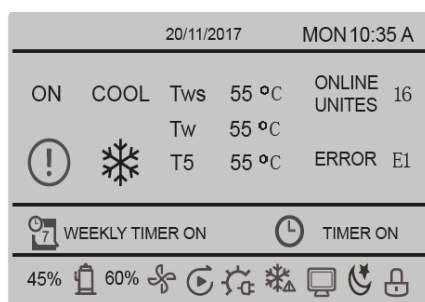





UNLOCK	To lockout / unlock.
▲▼	To modify current setpoint
MENU	To open the various menus from the HOME screen.
▲▼◀▶	To move the cursor, change the selection or change the set value. The parameter can be quickly changed with a long press.
OK	To confirm an operation.
ON/OFF	To set the ON / OFF function.
BACK	To return to the previous level. Press to exit the current page and return to the previous page. Long press to return straight to the home screen.

Units in modular configuration



On the slave controllers, only the password-protected SERVICE menu can be opened.



	Mode : cooling
OFF	Controller off
	Weekly timer active
45%	Compressor use value
	Compressor in operation.
60%	Fan use value
	Fan in operation
	Pump in operation
	Auxiliary electric heater in operation.
	Manual antifreeze or defrosting in operation
	Remote control: the unit is set from the keypad to be controlled by a remote terminal or by a remote switch
	SILENT Mode.
	Key lock
	Timer on
	Alarm: indicator on when there is a fault or a protection is tripped.

Units in modular configuration

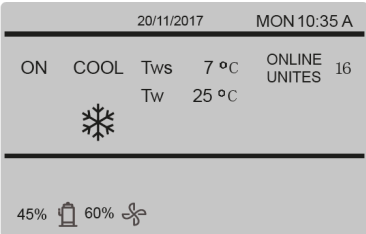
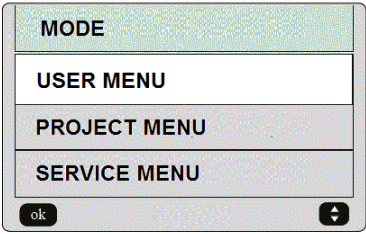
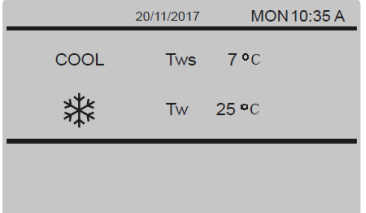
The information displayed on ALL controllers refers to the MASTER unit

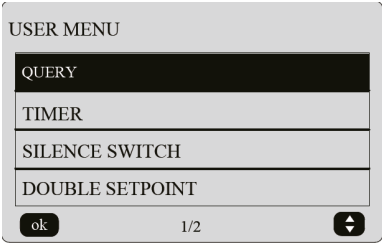
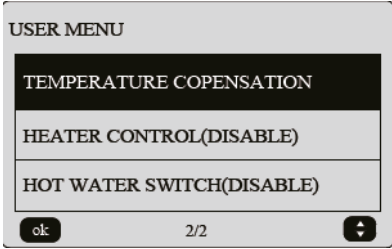
<p>In general: Press ▲▼ to adjust the values, scroll through the lists Press ◀▶ to select Press OK to go to the next menu Press BACK to go to the previous menu</p>	
<p>Unlock/lock To lockout the screen, press UNLOCK for 3 sec.</p> <p>Switch-on/off Press ON/OFF to switch-on/off</p>	
<p>Set MODE and TEMPERATURE Press MENU Press ▲▼ to select MODE Press OK Press ◀▶ to select the mode or the temperature Press ▲▼ to adjust the mode and temperature. Press OK to confirm. If no operations are performed for more than 60 seconds, the system automatically saves the settings and returns to the home page.</p> <p>Note During cooling with T ext < 15°C, the setpoint is forced to 10 °C (ref. Functioning limits)</p>	 
<p>Units in modular configuration On the slave controllers, only the password-protected SERVICE menu can be opened.</p>	
<p>USER MENU Press MENU</p> <div style="display: flex; justify-content: space-around;"> <div data-bbox="440 1747 823 1989">  </div> <div data-bbox="928 1742 1321 1989">  </div> </div>	

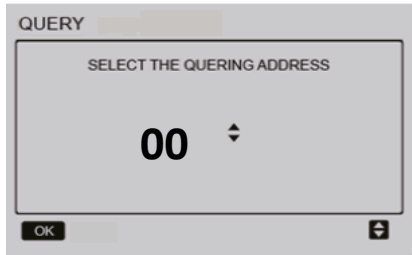
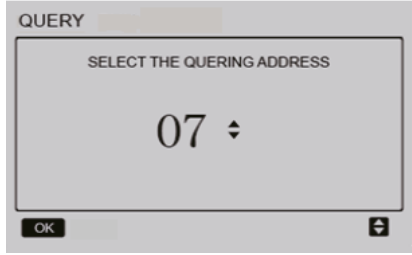
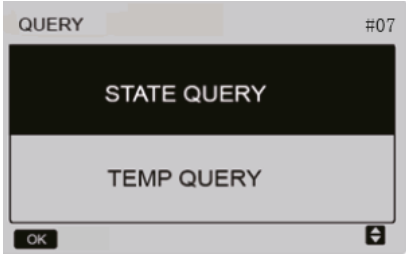
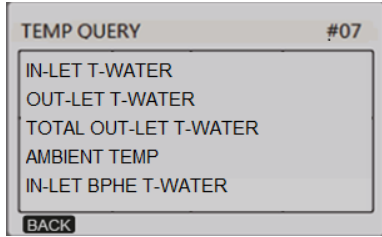
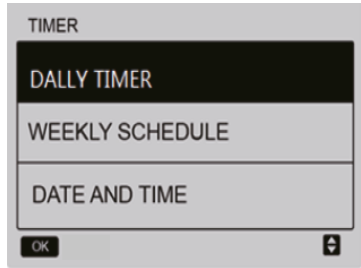
<p>USER MENU - QUERY</p> <p>.</p>										
<p>Only if multiple units are connected to the network</p> <p>Per visualizzare dati delle unità in rete: Press MENU Press ▲▼ to select QUERY Press ▲▼ to select the unit's address Press OK</p>										
<p>If STATE QUERY is selected: the unit's address is shown at top right (only for units in modular configuration)</p> <div style="display: flex; justify-content: space-around;"> <div data-bbox="209 943 616 1196">  </div> <div data-bbox="943 947 1329 1211"> <table border="1" style="border-collapse: collapse; text-align: center;"> <thead> <tr> <th colspan="3">STATE QUERY #07</th> </tr> </thead> <tbody> <tr> <td>OPERATION STATE</td> <td>RUNNING MODE</td> <td>CURRENT SILENT MODE</td> </tr> <tr> <td>ON</td> <td>COOL</td> <td>NIGHT SILENT MODE</td> </tr> </tbody> </table> <p>BACK</p> </div> </div>		STATE QUERY #07			OPERATION STATE	RUNNING MODE	CURRENT SILENT MODE	ON	COOL	NIGHT SILENT MODE
STATE QUERY #07										
OPERATION STATE	RUNNING MODE	CURRENT SILENT MODE								
ON	COOL	NIGHT SILENT MODE								
<p>If STATE QUERY is selected:</p>										
<p>USER MENU - TIMER</p> <p>Press MENU Press TIMER Select one of the 3 categories proposed If "DAILY TIMER" is selected, the "WEEKLY SHEDULE" cannot be activated and vice versa.</p>										

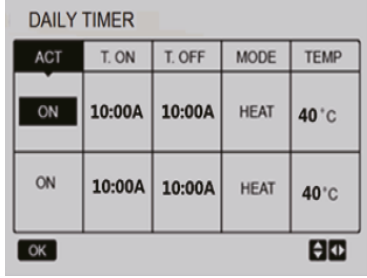
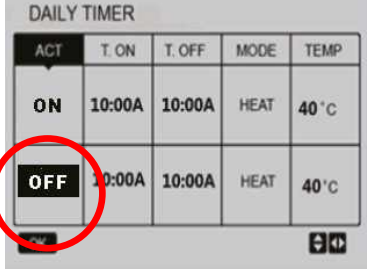
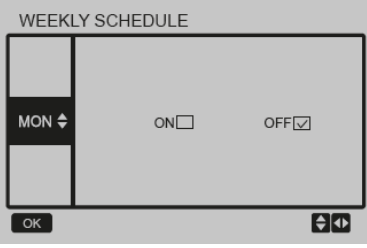
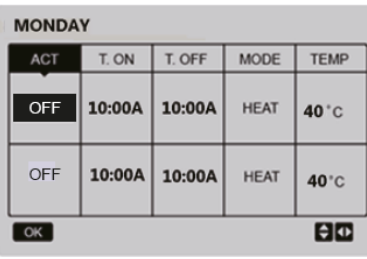
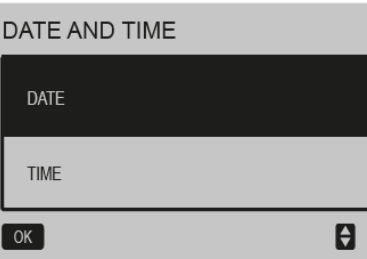
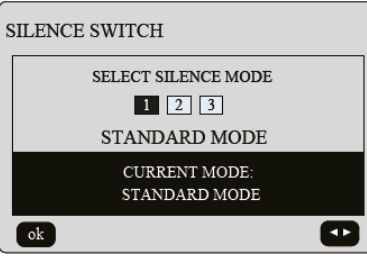
<p>TIMER menu - DAILY TIMER</p> <p>Press ON/OFF when the cursor is over the word ACT</p> <p>Press ◀▶ to select the starting time, the end time and the mode</p> <p>Press ▲▼ to set the time, mode, temperature.</p> <p>Press OK to confirm</p>	
<p>If two time bands overlap by mistake, the last one in the list is activated (OFF in the figure)</p>	
<p>TIMER menu - WEEKLY TIMER</p> <p>Select WEEKLY SCHEDULE</p> <p>Press ▲▼ to select the day</p> <p>Set ON or OFF</p> <p>Press OK to confirm</p>	
<p>Press ON/OFF when the cursor is over the word ACT</p> <p>Press ◀▶ to select the starting time, the end time and the mode</p> <p>Press ▲▼ to set the time, mode, temperature.</p> <p>Press OK to confirm</p>	
<p>TIMER menu - DATE and TIME</p> <p>Select DATE AND TIME</p> <p>Select DATE to change the date</p> <p>Select TIME to change the time</p>	
<p>USER menu - SILENT MODE SWITCH</p> <p>press ◀▶ to select the mode:</p> <p>Standard, Silent, Supersilent</p> <p>press OK to save the settings</p>	

USER menu - DOPPIO SETPOINT

Press ▲▼ to ENABLE or DISABLE.

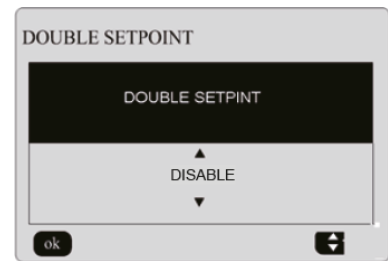

Abilitare il doppio setpoint

Press ◀▶ to select the setpoint mode

Press ▲▼ to adjust the parameters

The 2nd setpoint is activated only if the “temp-switch” input on the terminal block XT2 is closed

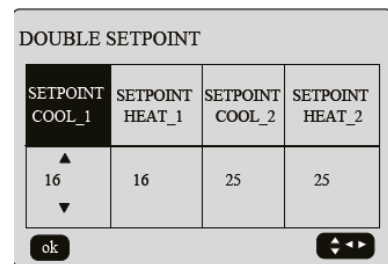

USER menu - TEMPERATURE COMPENSATION

The water temperature is adjusted based on the outdoor temperature T4.

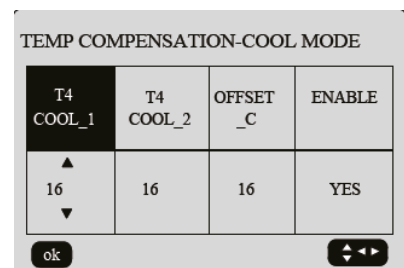

COOLING

The following parameters can be adjusted:

- T4_cool_1 (25~30°C)
- T4_cool_2 (30~40°C)

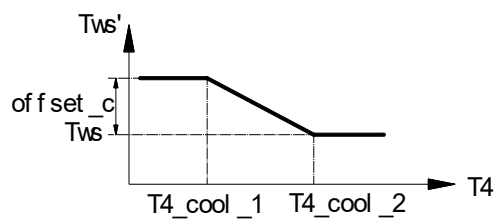

9 TROUBLESHOOTING

Alarm reset: turn off and on the unit..

⇒ *Before resetting an alarm identify and remove its cause.*

⇒ *Repeated resets can cause irreversible damage*

⇒ *Before carrying out any work, read the warnings in the Maintenance chapter*

Master unit

If there is a power failure to the Master unit, all the units in the group stops.

The unit is in protection in the following conditions

- 1 High pressure or protection due to drain temperature
- 2 low voltage
- 3 compressor current protection
- 4 frequency protection of the inverter compressor
- 5 condenser high temperature
- 6 high temperature difference between the entering water and the leaving water
- 7 antifreeze protection
- 8 drain temperature sensor malfunction
- 9 low evaporator temperature
- 10 frequency protection by voltage

11 compressor inverter malfunction

12 fan motor protection

13 water return high temperature, in cooling

14 low pressure antifreeze protection

15 High temperature of inverter compressor module

When the unit fails or is in protection, the water pump continues working (except for water flow alarm, voltage protection, phase sequence protection).

When the master unit is in protection, only the master unit stops and the other units carry on working.

When a slave unit is in protection, this unit stops and the other units are not involved .

If the master unit fails, the slave units also stop working.

Temperature sensors

All of the temperature sensors are classed as faulty when the voltage on the corresponding input is lower than 0.05 V or higher than 4.95 V.

After an error has been signalled, all units stop. The error is eliminated after the sensor has been restored.

Error code	Description	troubleshooting
1E0	EEPROM error - main board	
2E0	EEPROM error - inverter A module	
3E0	EEPROM error - inverter B module	
E1	phases sequence - control from main board	The three phases must be present at the same time and offset by 120° Restoring the power supply clears the error. Note: the power supply is checked only in the initial switch-on phase. It is not controlled when the unit is in operation.
E2	communication error between main board and keypad	If an error occurs between the wired controller and the master unit module, all of the slave units stop. If an error occurs in a slave unit (between the master unit and a slave unit), the slave module with the transmission error stops. The number of controlled units on the wired controller is reduced, the wired controller displays EC and the wired controller indicator flashes. The error is eliminated after the transmission has been restored. If an error occurs between slave units, both units stop. The master unit and the previous slave units are not involved.

Error code	Description	troubleshooting
E3	“Total” outlet water temperature probe Tw fault (only for master unit)	<p>Only the master unit controls the sensor fault, the slave unit does not control it.</p> <p>When the number of units in line is 2 or more, check if the Tw sensor is faulty or is not required.</p> <p>When the number of units in line is 1, Tw = Two by default; check if the Tw sensor is faulty or is not required.</p>
E4	Unit outlet water temperature probe - Two	
1E5	air coil temperature probe - T3a	
2E5	air coil temperature probe - T3B	
E7	Outdoor air temperature probe - T4	
E8	phases sequence	<p>It is controlled continuously.</p> <p>If the protection occurs on the master unit, all of the units stop and reset automatically.</p> <p>If the protection occurs on a slave unit, it stops and resets automatically, the master unit and the other slave units are not involved.</p>
E9	from flow switch: no flow / sensor failure from pressure switch: system low pressure / sensor failure	To reset it is necessary to remove power
2Eb	domestic hot water antifreeze alarm - Taf2	
EC	Slave unit module reduction	
1Ed	compressor drain temperature probe A	
2Ed	compressor drain temperature probe B	
1EE	economizer inlet temperature probe - T6a	
2EE	economizer outlet temperature probe - T6b	
EF	Unit inlet water temperature probe - Twi	
EH	autotest error	
EP	drain temperature probe	<p>Detection begins 10 minutes after start-up.</p> <p>The protection intervenes if the heating Pc is ≥ 3.5 MPa for 2 minutes or cooling Tz $\geq 56^{\circ}\text{C}$ and the drain temperature T_{pmax} $< 15^{\circ}\text{C}$.</p> <p>The entire unit stops.</p> <p>Turn the power off to reset it.</p>
EU	total condenser output high temperature - Tz	
P0	high pressure / drain temperature	If the protection intervenes 10 times in 150 minutes, turn the power off to reset it

Error code	Description	troubleshooting
P1	low pressure	At start-up the low pressure switch is bypassed for 3 minutes. If the protection intervenes 10 times in 150 minutes, turn the power off to reset it. If there is a remote control, turn the power off to reset it.
P2	total condenser output high temperature Tz	
P4	compressor A in protection	Absorption is not controlled during the first 10 seconds after the compressor has started. If the protection intervenes 10 times in 150 minutes, turn the power off to reset it. If there is a remote control, turn the power off to reset it.
P6	module error	
P7	condenser high temperature	
P8	Reserved	
P9	Inlet / outlet water temperature difference	If the protection intervenes 3 times in 60 minutes, turn the power off to reset it. Check: <ul style="list-style-type: none"> • that the Twi - Two probes are positioned correctly • the operation of the circulation pump • flow range within the permitted range
PA	Reserved	
Pb	winter antifreeze	
PC	evaporator low pressure in cooling	Check the water flow rate.
PE	antifreeze protection evaporator low temperature in cooling	If the protection intervenes 3 times in 60 minutes, turn the power off to reset it. Check that probe Two is correctly positioned.
PF	circuit board lock - controller lock/unlock error	
PH	high room temperature probe T4	
PL	Tfin module, high temperature	If the protection intervenes 3 times in 60 minutes, turn the power off to reset it.
1PP	IPM module error, circuit A	
2PP	IPM module error, circuit B	
1PU	fan A module	
2PU	fan B module	
3PU	fan C module	
1H9	driver compressor A - configuration error	
2H9	driver compressor B - configuration error	
H5	High / low voltage	

Error code	Description	troubleshooting
1HE	valve A error	
2HE	valve B error	
3HE	valve C error	
1F0	IPM module transmission error	
2F0	IPM module transmission error	
F2	insufficient overheating	Se la protezione interviene 3 volte in 240 minuti, per resettare è necessario togliere tensione.
1F3	Fan A transmission error	
2F3	Fan B transmission error	
3F3	Fan C transmission error	
1F4	protection L0 or L1 intervention 3 times in 60 minutes	
2F4	protection L0 or L1 intervention 3 times in 60 minutes	
1F6	circuit A bus voltage (PTC)	
2F6	circuit B bus voltage (PTC)	
F7	Reserved	
1F9	radiator temperature sensor Tfin1	
2F9	radiator temperature sensor Tfin2	
1FA	Reserved	
2FA	Reserved	
Fb	pressure sensor	Detection begins 15 minutes after start-up, if a pressure lower than 0.3 MPa is detected. Not detected during defrosting.
Fd	suction temperature sensor	
FE	recovery temperature sensor	
1FF	fan A	
2FF	fan B	
3FF	fan C	
FP	DIP switch for modular unit configuration error	
C7	3 times PL	
L0	module protection	
L1	low voltage	
L2	high voltage	
L4	MCE error	
L5	speed 0	
L7	no phase	
L8	variation of frequency higher than 15Hz	
L9	difference of phase frequency higher than 15Hz	
d0	Gate error (d0 and address alternatively displayed every 10 sec)	

STATUSES DISPLAY

Press UP on the main sheet

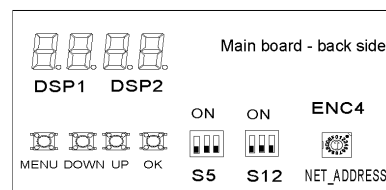

DSP1 DSP2	Standby: unit address (88 to the left) + online number (88 to the right) On: frequency
0.xx	unit address
1.xx	high pressure
2.xx	number of units
3.xx	T4 correction
4.xx	Mode (8: Off; 0: Standby; 1: Cooling)
5.xx	fan speed 1
6.xx	fan speed 2
7.xx	air coil temperature probe - T3
8.xx	Outdoor air temperature probe - T4
10.xx	domestic hot water antifreeze alarm Taf1
11.xx	plate exchanger antifreeze alarm Taf2
12.xx	Total outlet water temperature - Tw
t.xx	Unit inlet water temperature probe - Twi
14.xx	Unit outlet water temperature probe - Two
15.xx	liquid line (in cooling) temperature - Tz
16.xx	THeatR recovery
17.xx	supply 1
18.xx	supply 2
19.xx	Radiation fin temperature 1
20.xx	Radiation fin temperature 2
21.xx	saturated drain temperature (+25)
22.xx	Compressor current A
23.xx	Compressor current B
24.xx	Pump current
25.xx	electronic expansion valve opening A (/20)
27.xx	electronic expansion valve opening C (/4)
28.xx	high pressure
L.xx	low pressure
30.xx	overheating
31.xx	intake temperature
32.xx	silent
33.xx	static pressure

34.xx	DC voltage A (reserved)
35.xx	DC voltage B (reserved)
36.xx	frequency limit (0 = None; 1 = T4 ; 2 = pressure; 3 = drain; 4 = low pressure ratio; 5 = Real-time ; 6 = Current frequency ; 7: = voltage ; 8: Adjustment of energy requirement of pressure ratio ; 9 = low pressure in cooling)
37.xx	defrosting status (1st digit: T4 selection solution; 2nd digit: at intervals ; 3rd and 4th digit defrosting on timer)
38.xx	EPROM error: 1: Error; 0: No error
40.xx	initial frequency
42.xx	Te: Saturation temperature corresponding to low pressure in cooling mode
43.xx	economiser inlet temperature - T6a
44.xx	economiser outlet temperature - T6b
45.xx	software version
46.xx	last error
47.xx	----

10 MAINTENANCE

SAFETY WARNINGS FOR OPERATIONS ON UNITS CONTAINING R32

Area checks

Before working on systems containing flammable refrigerants, perform safety checks to reduce the risk of combustion to the minimum. Before performing any reparation operations on the cooling system, comply with the following warnings.

Work procedures

Operations must be performed following a controlled procedure so as to reduce the risk of flammable gases or vapours developing.

General work area

All the personnel in charge with maintenance operations and other operators working in the local area must be instructed and monitored as regards the nature of the intervention.

Avoid working in tight spaces. The area surrounding the working space must be cordoned off. Make sure the area is secured by monitoring the flammable material.

Check the presence of refrigerant

Both before and during operations, the area must be monitored with a dedicated refrigerant detector to make sure the technician is aware of the presence of potentially-flammable environments.

Make sure the leak detection equipment is suitable for use with flammable refrigerants and therefore without sparks, suitably sealed or intrinsically safe.

Presence of the fire extinguisher

If hot interventions are not performed on cooling equipment or connected components, suitable fire fighting equipment must be kept at hand.

Keep a dry-powder or CO₂ extinguisher near the loading area.

No ignition source

It is absolutely forbidden to use ignition sources that may lead to fire or explosion during operations on the cooling system or on pipes that contain or have contained flammable refrigerant.

All possible ignition sources, including cigarettes, must be kept sufficiently away from the installation, reparation, removal and disposal site as flammable refrigerant may be released in the surrounding area.

Before starting operations, the area surrounding the equipment must be inspected to guarantee the absence of flammables or combustion risks. "SMOKING IS FORBIDDEN" signs must be affixed.

Ventilated area

Before intervening on the system or performing any hot intervention, make sure to be in an outdoor or suitably ventilated area.

Ventilation must be maintained during operations. Ventilation must disperse the released refrigerant safely, preferably outdoors in the atmosphere.

Cooling equipment checks

Should a replacement be necessary, the new components installed must be suitable for the purpose envisaged and compliant with specifications.

Always follow the manufacturer guidelines on maintenance and assistance. In case of doubt, contact the manufacturer technical office for assistance.

The following checks must be performed on systems containing flammable refrigerants:

- the quantity of the charge must comply with the size of the room where the parts containing refrigerant are installed;
- the machine and ventilation intake function correctly and are not obstructed;
- If an indirect cooling circuit is used, the secondary circuits must be checked to verify the presence of refrigerants; the marking on the equipment remains visible and readable;
- Make sure markings and symbols are always readable; cooling pipes or components must be installed in a position that makes improbable their exposure to substances that may corrode the components

containing refrigerant, unless they are manufactured with material intrinsically resistant to corrosion or suitably protected against corrosion.

Electrical device checks

The reparation and maintenance of electric components must include initial safety checks and component inspection procedures.

In case of a fault that compromises safety, do not perform any electrical connection to the circuit until said fault is suitably resolved.

If it is not possible to repair the fault immediately and electrical components need to remain functioning, a temporary solution must be adopted. This must be reported to the owner of the equipment so as to keep all parties informed.

Initial safety checks must include:

- that condensers are emptied. This operation must be performed safely to avoid any sparks;
- that electrical components and wiring are not exposed during the charging, recovering or venting phases;
- That the earth conductor is continuous.

Repairing sealed components

- During the reparation operations of sealed components, disconnect all the equipment before removing sealed casings etc. If, during operations, it is absolutely necessary for the equipment to remain connected, a leak detection device must be placed in the most critical point so as to report any potentially-dangerous situation.
- Pay particular attention to what follows to guarantee that, while intervening on electrical components, the housing is not altered in a way so as to affect the level of protection. This includes damage to cables, an excessive number of connections, terminals not compliance with the original specifications, damage to gaskets, an unsuitable installation of gaskets, etc.
- Make sure the device is installed safely.
- Check that the seals or sealing materials are not altered in such a way that they no longer the impede the entry of flammable environments. Spare parts must comply with manufacturer specifications.

NOTE:

⇒ *Using silicone sealants may inhibit the effectiveness of a few types of leak detection equipment. It is not necessary to isolate intrinsically safe components before performing operations on them.*

Reparation of intrinsically safe components

Do not apply permanent inductive or capacitive loads to the circuit without making sure that they do not exceed the admissible voltage and current allowed for equipment in use.

Intrinsically safe components are the only component type on which operations can be performed in a flammable atmosphere. The testing device must show a correct value. Replace components only with the parts specified by the manufacturer.

Following a leak, other parts could lead to the combustion of the refrigerant in the atmosphere.

Wires

Make sure wires are not subjected to wear, corrosion, excessive pressure or vibration, that there are no sharp edges and that they do not produce other negative effects on the environment. The inspection must also keep into consideration the effects of time or the continuous vibration caused e.g. by compressors or fans.

Detection of flammable refrigerants

Under no circumstance is it possible to use potential ignition sources to search or detect refrigerant leaks. Do not use halide lights (or any other open flame detectors).

Leak detection methods

The following leak detection methods are considered acceptable for systems containing flammable refrigerants. Electric leak detectors must always be used to identify flammable refrigerants, although they do not present a suitable sensitivity level or require recalibration (detection equipment must be calibrated in an area free from refrigerants).

Check that the detector is not a possible source of ignition and that it is suitable for the refrigerant. Leak detection equipment must always be set to an LFL percentage and calibrated depending on the refrigerant used, so the correct gas percentage (25% max) must be verified.

Leak detection fluids are suitable for most refrigerants, although using detergents containing chlorine should be avoided as this substance may react with the refrigerant and corrode copper pipes.

If a leak is suspected, all open flames must be removed or switched off.

If a leak is identified that requires brazing, all the refrigerant must be recovered from the system or isolated (using interception valves) in a section of the system far away from the leak. Oxygen-Free-Nitrogen (OFN) is then purged through the system both before and during the brazing procedure.

Removal and evacuation

When intervening on the cooling circuit to perform repair work or any other type of work, always follow the normal procedure. However, considering the risk of flammability, we recommend following the best practices. Comply with the following procedure:

- remove the refrigerant;
- purge the circuit with inert gas;
- evacuate;
- Purge again with inert gas;
- Interrupt the circuit with interruption or brazing.

The refrigerant charge must be collected in suitable recovery tanks. To make the unit safe, flushing with Oxygen-free-Nitrogen must be performed. This procedure may have to be repeated multiple times. Do not use compressed air or oxygen for this operation.

Flushing is obtained interrupting the system vacuum with OFN and filling until the operating pressure is obtained, then releasing into the atmosphere and restoring the vacuum. This process must be repeated until there is no trace of refrigerant in the system.

When using the final OFN charge, the system must be vented to the atmospheric pressure to allow the intervention. This step is essential to perform brazing operations on the pipes.

Make sure that the vacuum pump intake is not near ignition sources and that there is suitable ventilation.

Charging operations

In addition to conventional charging operations, the following requirements must be complied with:

- When using charging equipment, make sure that the various refrigerants are not contaminated. Flexible tubes or conduits must be as short as possible to reduce to the minimum the quantity of refrigerant contained.
- Tanks must be kept in a vertical position.
- Before loading the system with refrigerant, check that the cooling system is earthed.
- Label the system when fully charged (unless already labelled).
- Make sure not to fill the cooling system excessively.
- Before recharging the system, the pressure must be tested with OFN. A leak test must be performed after the charging operations but before commissioning. Before leaving the site, perform an additional leak test.

Dismantling

Before performing this procedure, it is essential that the technician has become familiar with the equipment and the relative details.

We recommend employing good practices for a safe recovery of the refrigerants.

Before performing the operation, take a sample of oil and refrigerant should an analysis be necessary before reusing the regenerated refrigerant. Before performing the operation, check the availability of electricity.

- Become familiar with the equipment and how it functions.
- Electrically isolate the system.

Before attempting the procedure, check that:

- The mechanical manipulation equipment is available, if necessary, to handle refrigerant tanks;
- All the personal protection equipment is available and employed correctly;
- The recovery procedure is monitored at all times by skilled personnel;

- The recovery equipment and tanks comply with suitable standards.
- If possible, pump the cooling system.
- If it is not possible to obtain a vacuum, make sure that a collector removes the refrigerant from various parts of the system.
- Before proceeding with the recovery, check that the tank is located on the scales.
- Start up the recovery machine and use it following the instructions by the manufacturer.
- Do not fill the tanks excessively. (Do not exceed 80% of the liquid volume).
- Do not exceed the tank's maximum operating pressure, not even momentarily.
- Once the tanks are filled correctly and the process is over, make sure that the tanks and equipment are immediately removed from the site and that all insulation valves on the equipment are closed.
- The refrigerant recovered must not be loaded into another cooling system unless it has been cleaned and checked.

Labelling

Equipment must be labelled reporting the dismantling and emptying of the refrigerant.

Labels must be dated and signed.

Make sure all the equipment is labelled and reporting the presence of flammable refrigerant.

Recovery

When removing the refrigerant from the system, please adopt good practices to remove all refrigerants safely in case of both assistance or decommissioning operations.

When transferring the refrigerant into the tanks, make sure only suitable tanks are used to recover the refrigerant.

Make sure enough tanks are used.

All the tanks to be used are designated for the recovered refrigerant and are labelled for that specific refrigerant (e.g. special tanks for refrigerant collection).

Tanks must be equipped with a perfectly-functioning safety valve and relative interception valves.

Empty recovery tanks are evacuated and, if possible, cooled before recovery.

Recovery equipment must be perfectly functioning with the respective instruction booklets at hand and they must be suitable to recover flammable refrigerants. A series of perfectly-functioning calibrated scales must also be available.

Flexible tubes must be equipped with leak-proof disconnection fittings in good condition. Before using the recovery machine, make sure it is in good condition, maintained and that all associated electrical components are sealed to avoid combustion in case of a refrigerant leak. Please contact the manufacturer in case of doubt.

The refrigerant recovered must be taken to the supplier in suitable recovery tanks and with the relative waste transfer note suitably filled in.

Do not mix the refrigerants in the recovery units nor in the tanks.

If it is necessary to remove compressors or compressor oils, make sure they are evacuated to an acceptable level to make sure no trace is left of the flammable refrigerant inside the lubricant. The evacuation process must be performed before taking the compressors back to the suppliers.

The electric resistance must be used with the compressor body only to accelerate this process.

Operations to discharge the oil from the system must be performed in full safety.

Transport, mark and storage

- 1 Transport of equipment containing flammable refrigerants
Compliance with transport regulations
- 2 Marking of equipment with symbols
Compliance with local regulations
- 3 Disposal of equipment employing flammable refrigerants
Compliance with national regulations
- 4 Storage of equipment/devices
The equipment must be stored in compliance with the instructions provided by the manufacturer.
- 5 Storing packed (unsold) equipment
Packing must be performed in such a way that mechanical damage to the equipment inside it does not cause refrigerant leaks.
The maximum number of elements that can be stored together is determined by local regulations.

Safety

Operate in compliance with safety regulations in force .
Use single protection devices: gloves, glasses, helmet etc.
usare dispositivi di protezione: guanti, occhiali, elmetto ecc.

General

Maintenance must be performed by authorized centres or by qualified personnel

The maintenance allows to:

- maintaining the unit efficient
- reduce the deterioration speed all the equipment is subject to over time
- collect information and data to understand the efficiency state of the unit and prevent possible faults

WARNING

- ⇒ *Before checking, please verify the following:*
- ⇒ *the electrical power supply line should be isolated at the beginning*
- ⇒ *the line isolator device is open, locked and equipped with the suitable warning sign*
- ⇒ *make sure no tension is present*
- ⇒ *After switching the power off, wait at least 5 minutes before accessing to the electrical panel or any other electrical component.*
- ⇒ *Before accessing check with a multimeter that there are no residual stresses.*

Frequency of interventions

Perform an inspection every 6 months.

However, frequency depends on the type of use.

Pan inspections at close intervals in the event of:

- frequent use (continuous or very intermittent use, near the operating limits, etc)
- critical use (service necessary)

WARNING

- ⇒ *Before performing any work, please read carefully: SAFETY WARNINGS FOR OPERATIONS ON UNITS CONTAINING R32*

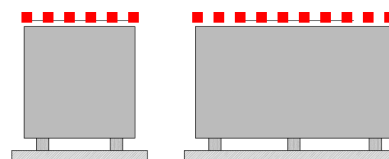

	intervention frequency (months)	1	6	12
1	Presence of corrosions			X
2	Panel fixing			X
3	Fan fixing		X	
4	coil cleaning		X	
5	Water filter cleaning		X	
6	water: quality, pH, glycol concentration		X	
7	check exchanger efficiency			X
8	circulation pump		X	
9	Check of the fixing and the insulation of the power lead			X
10	earth cable check			X
11	Electric panel cleaning			X
12	power remote controls status			X
13	clamp closure, cable isolation integrity			X
14	Voltage and phase unbalancing (no load and on-load)		X	
15	Absorptions of the single electrical loads		X	
16	compressor casing heaters test		X	
17	Checking for leaks *			*
18	cooling circuit work parameter detection		X	
19	safety valve *			*
20	protective device test: pressure switches, thermostats, flow switches etc..			X
21	control system test: setpoint, climatic compensations, capacity stepping, air flow-rate			X
22	Control device test: alarm signalling, thermometers, probes, pressure gauges etc			X

NOTE

⇒ Refer to the local regulations. Companies and technicians performing installation, maintenance/repair, leak control and recovery operations must be CERTIFIED as set out by the local regulations.

Unit booklet

Foresee a unit schedule to keep trace of the interventions made on the unit.

In this way, it will be easier to adequately schedule the various interventions and facilitate any troubleshooting.

On the schedule note:

- date
- intervention description
- carried out measures etc.

Standby mode

If foreseen a long period of inactivity:

- turn off the power
- Prevent the risk of freezing (use glycol or empty the system) disconnect voltage to avoid electric risks or damages following lightning

With lower temperatures keep heaters turned on in of the electrical panel (option).

It is recommended to have a qualified technician start the system after a period of inactivity, especially after seasonal stops or for seasonal switch-overs.

When starting, follow the instructions in the “start-up” section.

Schedule technical assistance in advance to avoid hitches and to guarantee that the system can be used when required.

System drain

The system must be drained only if necessary.

Avoid draining the system periodically; corrosive phenomena can be generated.

- 1 Empty the system
- 2 empty the exchanger, use all shut-off valves and grub screws
- 3 blow the exchanger with compressed air
- 4 dry the exchanger with hot air; for greater safety, fill the exchanger with glycol solution
- 5 protect the exchanger from air
- 6 take the drain caps off the pumps

Any anti-freeze liquid contained in the system should not be discharged freely as it is a pollutant. It must be collected and reused.

Before start-up, wash the system.

It is recommended to have a qualified technician start the system after a period of inactivity, especially after seasonal stops or for seasonal switch-overs.

When starting, follow the instructions in the “start-up” section.

Schedule technical assistance in advance to avoid hitches and to guarantee that the system can be used when required.

Compressor casing heater

Check:

- closure
- Operation

Water side heat exchanger

The exchanger must be able to provide the maximum thermal exchange, therefore it is essential for the inner surfaces to be clean of dirt and build-up.

Periodically check the difference between the temperature of the supply water and the condensation temperature: if the difference is greater than 8°C–10°C it is advisable to clean the exchanger.

The clearing must be effected:

- with circulation opposite to the usual one
- with a speed at least 1,5 times higher than the nominal one
- with an appropriate product moderately acid (95% water + 5% phosphoric acid)
- after the cleaning rinse with water to inhibit the action of any residual product

Water filter

Check that no impurities prevent the correct passage of water.

Flow switch

- controls the operations
- remove incrustations from the palette

Circulation pumps

Check:

- no leaks
- Bearing status (anomalies are highlighted by abnormal noise and vibration)
- The closing of terminal covers and the correct positioning of the cable glands.

Electric fans

Check:

- the fans and the relative protection grids are well fixed
- the fan bearings (evident by noise and anomalous vibrations)
- the terminal protection covers are closed and the cable holders are properly positioned.

Insulations

Check the condition of the insulations: if necessary, apply glue and renew the seals.

Structure

Wash with warm water.

⇒ *Do not use chemicals.*

Check the state of the structure and the presence of oxidation.

Paint if necessary.



Air coil

⇒ *Accidental contact with the exchanger fins can cause cuts: wear protective gloves.*

The coil must allow maximum thermal exchange, therefore, the surface must be clear from dirt and scaling.

It is recommended a quarterly cleaning of the coils, as the minimum.

The cleaning frequency should be increased depending on the level of dirt/dust accumulation and the environment (e.g., coastal areas with chlorides and salts) or industrial areas with aggressive substances.

Shut down periods

During periods when the unit is not operated for longer than a week, the coil must be completely cleaned following the cleaning procedure. .

Cleaning procedure

Relative to tube & fin heat exchangers, these coils tend to accumulate more dirt on the surface of the coil and less dirt inside the coil, making them easier to clean.

Follow the steps below for proper cleaning.

Remove surface debris

Remove surface dirt, leaves, fibers, etc. with a vacuum cleaner (preferably with a brush or other soft attachment rather than a metal tube), compressed air blown from the inside out, and/or a soft bristle (not wire!) brush. Do not impact or scrape the coil.

Rinse

Rinse only with water. Do not use any chemicals to clean heat exchangers, as they may cause corrosion.

Hose off gently, preferably from the inside-out and top to bottom, running the water through every fin passage until it comes out clean.

The fins are stronger than other coil fins but still need to be handled with care. Do not hit the coil with the hose.

We do not recommend using a pressure washer to clean the coil due to the possibility of damage. Warranty claims related to cleaning damage, especially from pressure washers, or corrosion resulting from chemical coil cleaners, will NOT be honored.

Blow dry

MicroChannel heat exchangers could possibly retain more water compared to traditional tube & fin coils. It is advised to blow off or vacuum out the residual water from the coil to speed up drying and prevent pooling.

WARNING

Field applied coatings are not recommended for brazed aluminum MicroChannel heat exchangers.

Safety valve

The pressure relief valve must be replaced :

- if it has intervened
- if there is oxidation
- based on the date of manufacture, in compliance with local regulations.

Valve replacing

The 3-piece joint allows the valve replacement.

1. turn off the shut-off valve
2. remove the safety valve
DO NOT WARM THE PIECE
3. remove the valve from the joint
4. assemble the new valve to the joint
clean the parts to be assembled and apply white paste
5. install the new valve
6. turn on the shut-off valve

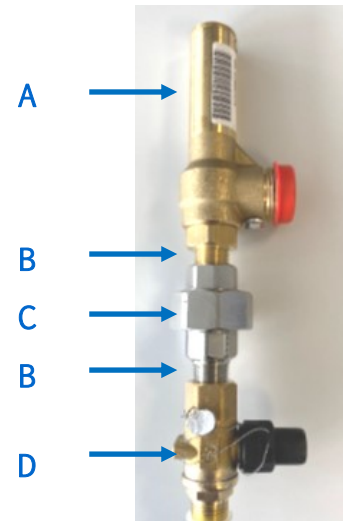

- A safety valve
- B white paste
- C joint 3 pieces
- D shut-off valve

2

3

4

5

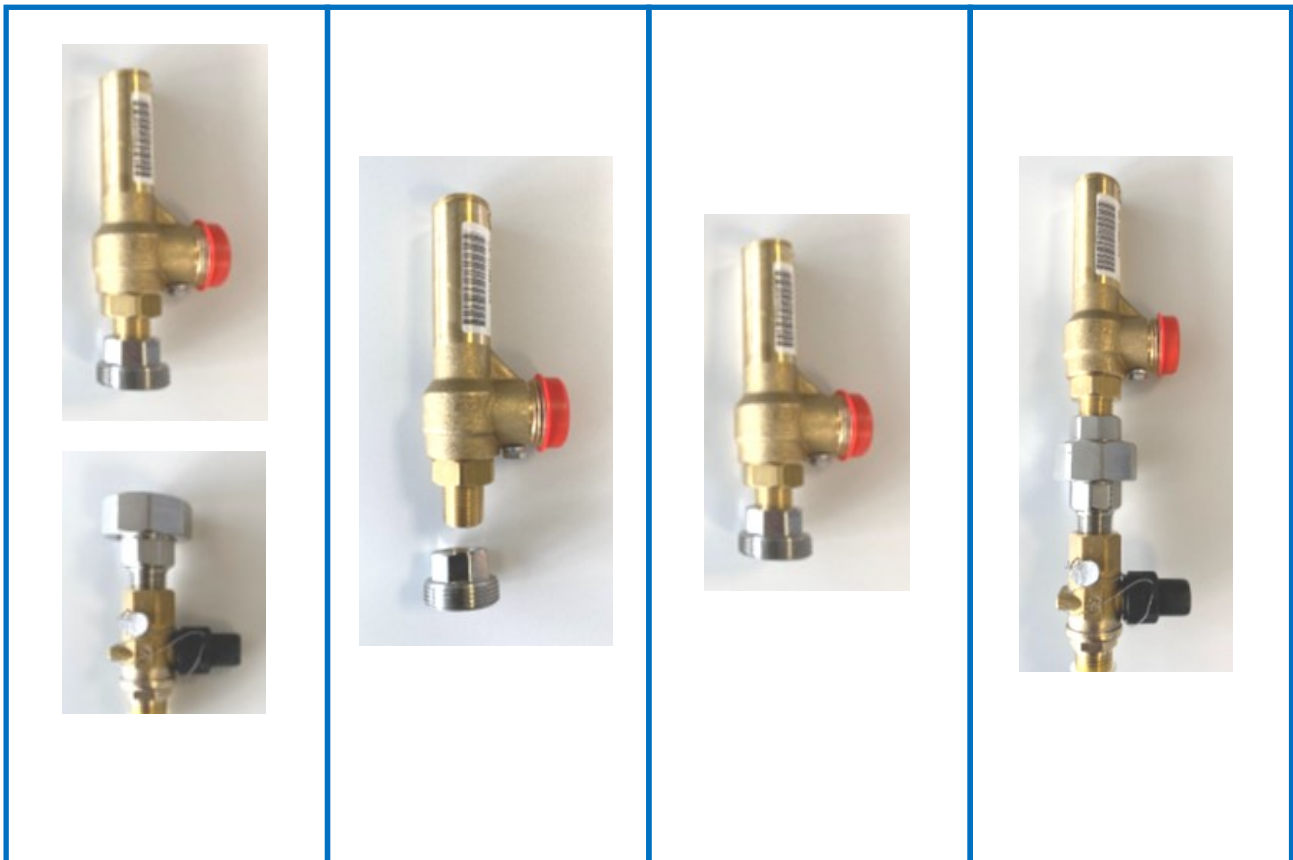

Exchanger replacement

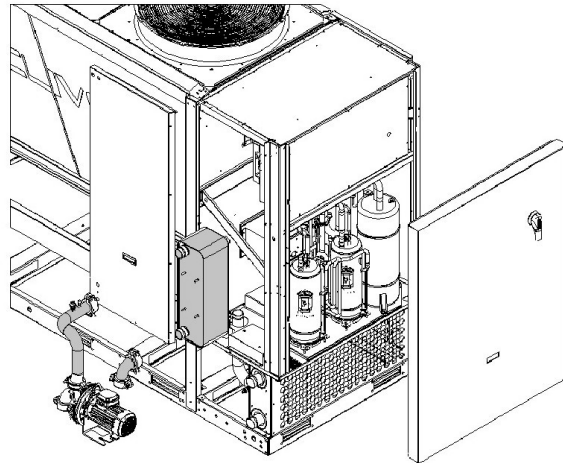

Compressor replacement

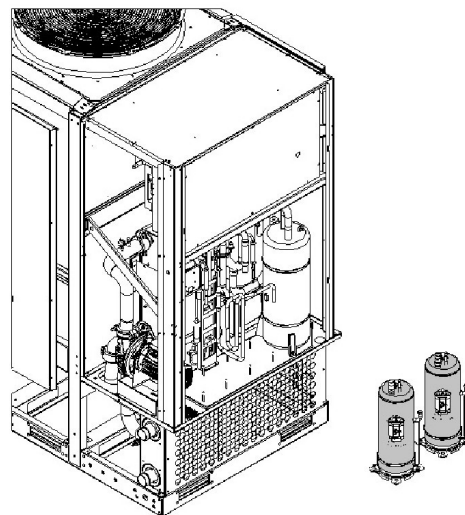

Pump replacement

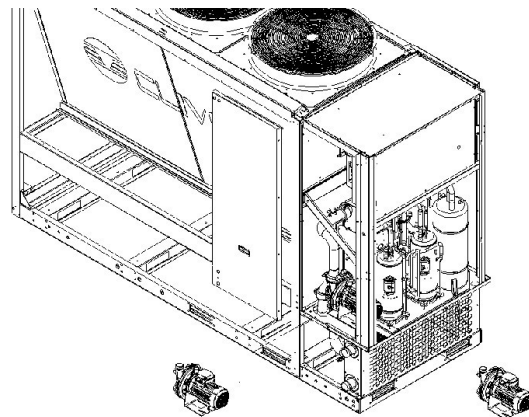

11 DECOMMISSIONING

Disconnection

WARNING

⇒ Before performing any operation, read the warnings found in the Maintenance chapter.

Avoid leak or spills into the environment.

Before disconnecting the unit, the following must be recovered, if present:

- refrigerant gas
- Anti-freeze solutions in the hydraulic circuit

Awaiting decommissioning and disposal, the unit can also be stored outdoors, as bad weather and rapid changes in temperature do not harm the environment provided that the electric, cooling and hydraulic circuits of the unit are intact and closed.

WEEE INFORMATION

The manufacturer is registered on the EEE National Register, in compliance with implementation of Directive 2012/19/EU and relevant national regulations on waste electrical and electronic equipment.

This Directive requires electrical and electronic equipment to be disposed of properly.

Equipment bearing the crossed-out wheelie bin mark must be disposed of separately at the end of its life cycle to prevent damage to human health and to the environment.

Electrical and electronic equipment must be disposed of together with all of its parts.

To dispose of “household” electrical and electronic equipment, the manufacturer recommends you contact an authorised dealer or an authorised ecological area.

“Professional” electrical and electronic equipment must be disposed of by authorised personnel through established waste disposal authorities around the country.

In this regard, here is the definition of household WEEE and professional WEEE:

WEEE from private households: WEEE originating from private households and WEEE which comes from commercial, industrial, institutional and other sources which, because of its nature and quantity, is similar to that from private households. Subject to the nature and quantity, where the waste from EEE was likely to have been by both a private household and users of other than private households, it will be classed as private household WEEE;

Professional WEEE: all WEEE which comes from users other than private households.

This equipment may contain:

refrigerant gas, the entire contents of which must be recovered in suitable containers by specialised personnel with the necessary qualifications;

- lubrication oil contained in compressors and in the cooling circuit to be collected;
- mixtures with antifreeze in the water circuit, the contents of which are to be collected;
- mechanical and electrical parts to be separated and disposed of as authorised.

When machine components to be replaced for maintenance purposes are removed or when the entire unit reaches the end of its life and needs to be removed from the installation, waste should be separated by its nature and disposed of by authorised personnel at existing collection centres.



Warning:
Fire hazard
Flammable materials



12 RESIDUAL RISKS

General

In this section the most common situations are indicated, as these cannot be controlled by the manufacturer and could be a source of risk situations for people or things.

Danger zone

This is an area in which only an authorised operator may work.

The danger zone is the area inside the unit which is accessible only with the deliberate removal of protections or parts thereof.

Handling

The handling operations, if implemented without all of the protection necessary and without due caution, may cause the drop or the tipping of the unit with the consequent damage, even serious, to persons, things or the unit itself.

Handle the unit following the instructions provided in the present manual re-garding the packaging and in compliance with the local regulations in force.

Should the refrigerant leak please refer to the refrigerant "Safety sheet".

Installation

The incorrect installation of the unit could cause water leaks, condensate accumulation, leaking of the refrigerant, electric shock, poor operation or damage to the unit itself.

Check that the installation has been implemented by qualified technical personnel only and that the instructions contained in the present manual and the local regulations in force have been adhered to.

The installation of the unit in a place where even infrequent leaks of inflammable gas and the accumulation of this gas in the area surrounding the area occur could cause explosions or fires.

Carefully check the positioning of the unit.

The installation of the unit in a place unsuited to support its weight and/or guarantee adequate anchorage may result in consequent damage to things, people or the unit itself.

Carefully check the positioning and the anchoring of the unit.

Easy access to the unit by children, unauthorised persons or animals may be the source of accidents, some serious.

Install the unit in areas which are only accessible to authorised person and/or provide protection against intrusion into the danger zone.

General risks

Smell of burning, smoke or other signals of serious anomalies may indicate a situation which could cause damage to people, things or the unit itself.

Electrically isolate the unit.

Contact the authorised service centre to identify and resolve the problem at the source of the anomaly.

Accidental contact with exchange batteries, compressors, air delivery tubes or other components may cause injuries and/or burns.

Always wear suitable clothing including protective gloves to work inside the danger zone.

Maintenance and repair operations carried out by non-qualified personnel may cause damage to persons, things or the unit itself.

Always contact the qualified assistance centre.

Failing to close the unit panels or failure to check the correct tightening of all of the panelling fixing screws may cause damage to persons, things or the unit itself.

Periodically check that all of the panels are correctly closed and fixed.

If there is a fire the temperature of the refrigerant could reach values that increase the pressure to beyond the safety valve with the consequent possible projection of the refrigerant itself or explosion of the circuit parts that remain isolated by the closure of the tap.

Do not remain in the vicinity of the safety valve and never leave the refrigerating system taps closed.

Electric parts

An incomplete attachment line to the electric network or with incorrectly sized cables and/or unsuitable protective devices can cause electric shocks, intoxication, damage to the unit or fires.

Carry out all of the work on the electric system referring to the electric layout and the present manual ensuring the use of a system thereto dedicated.

An incorrect fixing of the electric components cover may lead to the entry of dust, water etc inside and may consequently electric shocks, damage to the unit or fires.

Always fix the unit cover properly.

When the metallic mass of the unit is under voltage and is not correctly connected to the earthing system it may be as source of electric shock and electrocution.

Always pay particular attention to the implementation of the earthing system connections.

Contact with parts under voltage accessible inside the unit after the removal of the guards can cause electric shocks, burns and electrocution.

Open and padlock the general isolator prior to removing the guards and signal work in progress with the appropriate sign.

Contact with parts that could be under voltage due to the start up of the unit may cause electric shocks, burns and electrocution.

When voltage is necessary for the circuit open the isolator on the attachment line of the unit itself, padlock it and display the appropriate warning sign.

Moving parts

Contact with the transmissions or with the fan aspiration can cause injuries.

Prior to entering the inside of the unit open the isolator situated on the connection line of the unit itself, padlock and display the appropriate warning sign.

Contact with the fans can cause injury.

Prior to removing the protective grill or the fans, open the isolator on the attachment line of the unit itself, padlock it and display the appropriate warning sign.

Refrigerant

The intervention of the safety valve and the consequent expulsion of the gas refrigerant may cause injuries and intoxication.

Always wear suitable clothing including protective gloves and eyeglasses for operations inside the danger zone.

Should the refrigerant leak please refer to the refrigerant "Safety sheet".

Contact between open flames or heat sources with the refrigerant or the heating of the gas circuit under pressure (e.g. during welding operations) may cause explosions or fires.

Do not place any heat source inside the danger zone.

The maintenance or repair interventions which include welding must be carried out with the system off.

Hydraulic parts

Defects in tubing, the attachments or the removal parts may cause a leak or water projection with the consequent damages to people, things or shortcircuit the unit.

Performance

SIZE			18.2	20.2	25.2	30.2	35.2
Radiant panels							
Cooling							
Cooling capacity (EN 14511:2018)	kW	1/4	61,7	72,1	88,1	94,5	108
EER (EN 14511:2018)		2	4,30	3,96	4,44	4,28	4,02
Water flow-rate	l/s	1	2,95	3,44	4,21	4,51	5,14
User side exchanger pressure drops	kPa	1	33,4	44,7	65,2	74,4	95,1
Terminal unit							
Cooling							
Cooling capacity (EN 14511:2018)	kW	3	53,1	59,2	72,2	77,5	85,1
EER (EN 14511:2018)		2	3,10	3,00	3,21	3,20	3,10
SEER (EN 14511:2018)		5	4,85	4,84	4,89	4,81	4,74
Water flow-rate	l/s	5	2,54	2,83	3,45	3,70	4,07
User side exchanger pressure drops	kPa	3	25,2	30,9	31,3	35,8	42,8
Dati AHRI							
Cooling capacity (AHRI 550/590)	kW	6	61,3	69,1	80,7	88,1	95,5
Total power input (AHRI 550/590)	kW	6	12,9	14,3	16,2	18,3	20,4
COP _R		6	4,75	4,83	4,98	4,81	4,68
IPLV		6	5,24	5,23	5,20	5,12	5,04

The Product is compliant with the ErP (Energy Related Products) European Directive. It includes the Commission delegated Regulation (EU) No 811/2013 (rated heat output ≤ 70 kW at specified reference conditions) and the Commission delegated Regulation (EU) No 813/2013 (rated heat output ≤ 400 kW at specified reference conditions). Contains fluorinated greenhouse gases (GWP 675).

1. Entering/leaving water temperature user side 23/18 °C, Entering external exchanger air temperature 35 °C.
2. EER (EN 14511:2018) cooling performance coefficient. Ratio between delivered cooling capacity and power input in compliance with EN 14511:2018.
3. User side entering/leaving water temperature 12/7 °C, external exchanger entering air 35 °C.
4. Data referred to unit operation with inverter frequency optimized for this application..
5. Data calculated according to the EN 14825:2016 Regulation.
6. Data compliant to Standard AHRI 550/590 referred to the following conditions: internal exchanger water temperature = 6,7 °C. Water flow-rate 0,043 l/s per kW. Entering external exchanger air temperature 35°C. Evaporator fouling factor = $0,18 \times 10^{(-4)} \text{ m}^2 \text{ K/W}$.

General technical data

Construction

SIZE		18.2	20.2	25.2	30.2	35.2
Compressor						
Compressor type		ROTARY INVERTER			SCROLL INVERTER	
Refrigerant		R32				
N° compressor	Nr	2	2	2	2	2
Oil charge	l	5	5	6	6	6
Refrigerant charge	Kg	6,3	6,3	9,0	9,0	9,0
N° circuits	Nr	1	1	1	1	1
User side exchanger						
Type of internal exchanger	1	BPHE				
Water content	l	5,7	5,7	7,8	7,8	7,8
External Section Fans						
Fans type		BRUSHLESS DC MOTOR				
N° fans	Nr	2	2	3	3	3
Standard air-flow	l/s	6889	6889	10333	10333	10333
Installed unit power	kW	0,9	0,9	0,9	0,9	0,9
Water circuit						
Maximum water side pressure	MPa	1	1	1	1	1
Minimum circuit water volume in cooling	2 l	150	150	200	200	200
Total internal water volume	l	5,9	5,9	8,0	8,0	8,0
Power supply						
Standard power supply		400/3/50+N	400/3/50+N	400/3/50+N	400/3/50+N	400/3/50+N

1. BPHE = plate exchanger
2. Entering/leaving water temperature user side 15/10 °C, external exchanger entering air 25°C (U.R. = 85%) - Minimum water volume that does not consider the volume of water inside the unit.

Sound levels Standard mode

Size	Sound power level								Sound pressure level	Sound power level
	Octave band (Hz)									
	63	125	250	500	1000	2000	4000	8000	dB(A)	dB(A)
18.2	62	67	68	72	79	72	64	52	64	82
20.2	68	79	76	73	76	67	59	52	65	82
25.2	65	66	69	73	80	73	65	51	62	81
30.2	59	67	69	72	80	73	65	51	65	84
35.2	87	77	76	76	79	68	60	53	67	85

Sound levels refer to units with nominal test conditions.
The sound pressure level refers to a distance of 1 meter from the outer surface of the unit operating in open field.
Noise levels are determined using the tensiometric method (UNI EN ISO 9614-2)

Data referred to the following conditions in cooling:
- internal exchanger water = 12/7°C
- ambient temperature 35°C

Silenced mode

Size	Sound power level								Sound pressure level	Sound power level
	Octave band (Hz)									
	63	125	250	500	1000	2000	4000	8000	dB(A)	dB(A)
18.2	54	57	62	67	66	64	57	46	56	74
20.2	73	65	70	69	65	62	55	49	56	74
25.2	66	57	60	68	67	65	56	43	58	76
30.2	61	55	59	67	66	63	55	41	58	76
35.2	86	67	69	70	63	58	54	47	58	76

Sound levels refer to units with nominal test conditions.
The sound pressure level refers to a distance of 1 meter from the outer surface of the unit operating in open field.
Noise levels are determined using the tensiometric method (UNI EN ISO 9614-2)

Data referred to the following conditions in cooling:
- internal exchanger water = 12/7°C
- ambient temperature 35°C

Silenced mode can be set from the user interface terminal

Super silenced mode

Size	Sound power level								Sound pressure level	Sound power level
	Octave band (Hz)									
	63	125	250	500	1000	2000	4000	8000	dB(A)	dB(A)
18.2	48	51	57	62	58	61	56	44	52	70
20.2	68	64	70	64	59	62	54	48	53	71
25.2	69	58	59	66	62	59	51	40	53	71
30.2	61	49	56	64	61	59	52	39	53	71
35.2	86	63	58	68	60	56	54	48	55	73

Sound levels refer to units with nominal test conditions.
The sound pressure level refers to a distance of 1 meter from the outer surface of the unit operating in open field.
Noise levels are determined using the tensiometric method (UNI EN ISO 9614-2)

Data referred to the following conditions in cooling:
- internal exchanger water = 12/7°C
- ambient temperature 35°C

Super Silenced mode can be set from the user interface terminal

At maximum conditions data

Size	Sound power level								Sound pressure level	Sound power level
	Octave band (Hz)									
	63	125	250	500	1000	2000	4000	8000	dB(A)	dB(A)
18.2	55	65	67	72	77	70	61	50	67	83
20.2	55	65	67	72	77	70	61	50	67	83
25.2	57	67	69	73	79	72	64	51	69	85
30.2	57	67	69	73	79	72	64	51	69	85
35.2	57	67	69	73	79	72	64	51	69	85

Sound levels refer to units with nominal test conditions.
The sound pressure level refers to a distance of 1 meter from the outer surface of the unit operating in open field.
Noise levels are determined using the tensiometric method (UNI EN ISO 9614-2)

Operating range - Cooling

Size 18.2 - 20.2 - 25.2 - 30.2 - 35.2

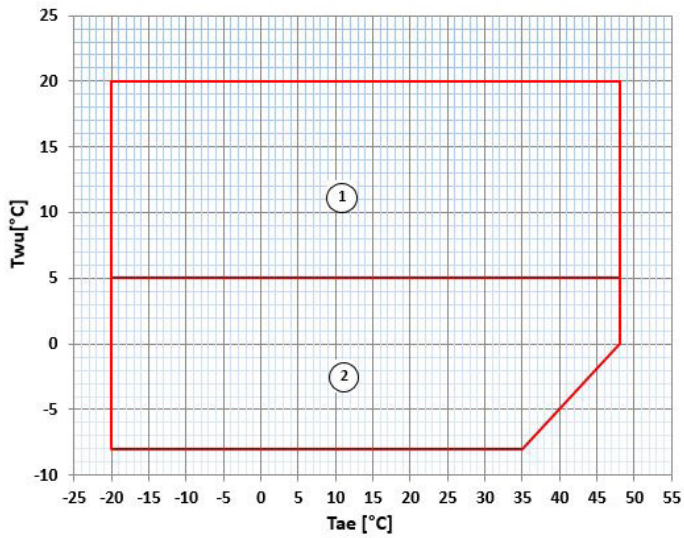

Twu [°C] = Leaving exchanger water temperature
Tae [°C] = External exchanger inlet air temperature

1. Normal operating range
2. Operating range where the use of ethylene glycol is mandatory in relation to the temperature of the water at the outlet of the user side exchanger

Overload and control device calibrations

		Open	Close	Value
Refrigerant side				
High pressure safety switch	kPa	4200	3200	-
Low pressure safety switch	kPa	50	130	-
Low pressure safety valve	kPa	-	-	3000
Compressor discharge high temperature safety thermostat	°C	115	75	-
Water side				
Antifreeze protection	°C	4	20	-
High pressure safety valve	kPa	-	-	600*

* The value entered refers to units supplied with a hydronic group installed on board

Size 18.2 - 20.2

DAASF0001_REV00
Data/Date 01/04/2021

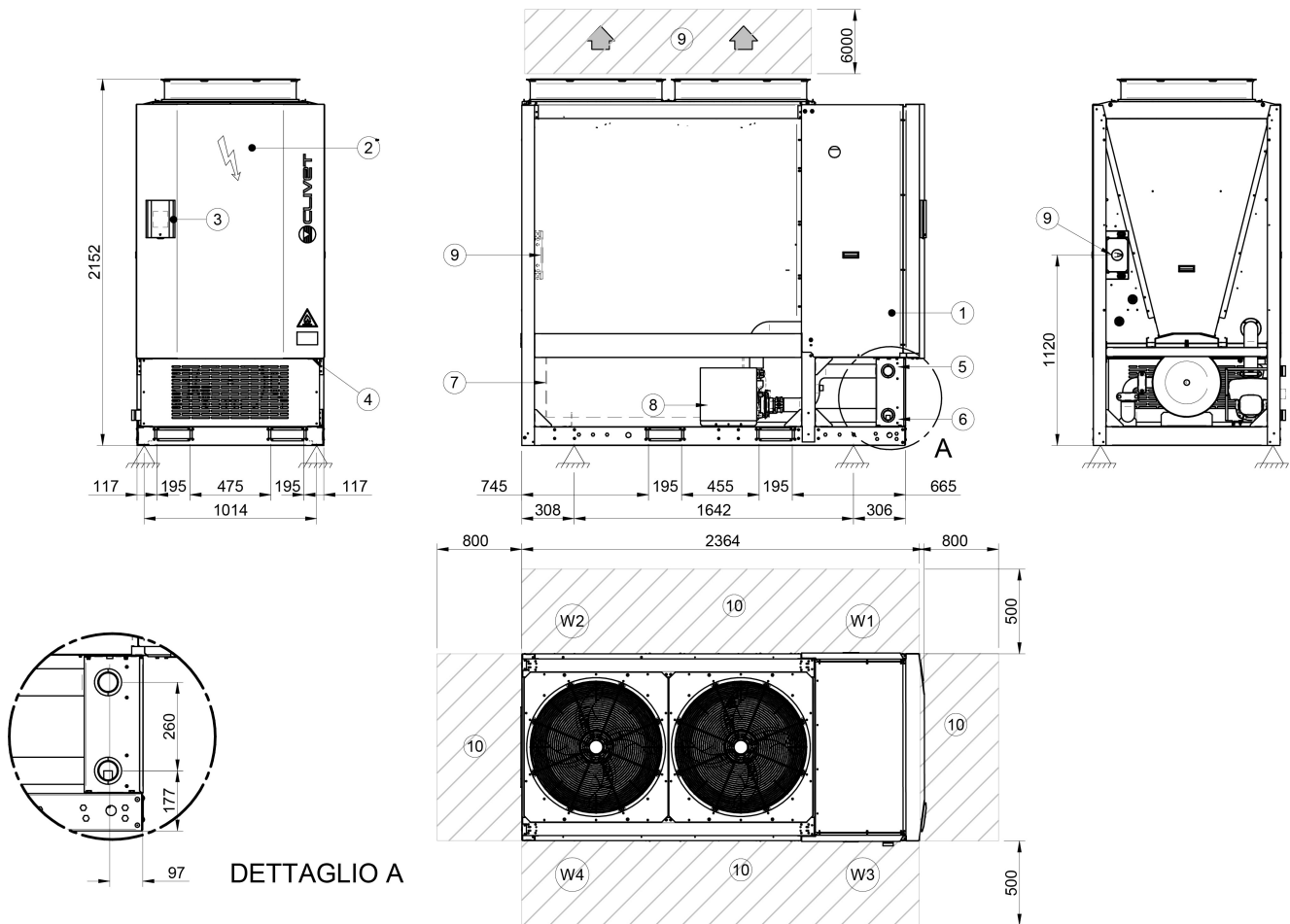

1. Compressor compartment
2. Electrical panel
3. Control keypad
4. Power input
5. Water inlet 2" Victaulic
6. Water outlet 2" Victaulic
7. Water tank**
8. Pump**
9. Isolating switch**
10. Functional spaces

**Optional

SIZE		18.2	20.2
Lenght	mm	2364	2364
Depth	mm	1130	1130
Height	mm	2152	2152
Operating weight	kg	575	575
Shipping weight	kg	560	560
Weight with water tank	kg	615	615
Shipping weight with water tank	kg	800	800

The presence of optional accessories may result in a substantial variation of the weights shown in the table.

Dimensional drawings

Size 25.2 - 30.2 - 35.2

DAASF0002_REV01
Data/Date 01/04/2021

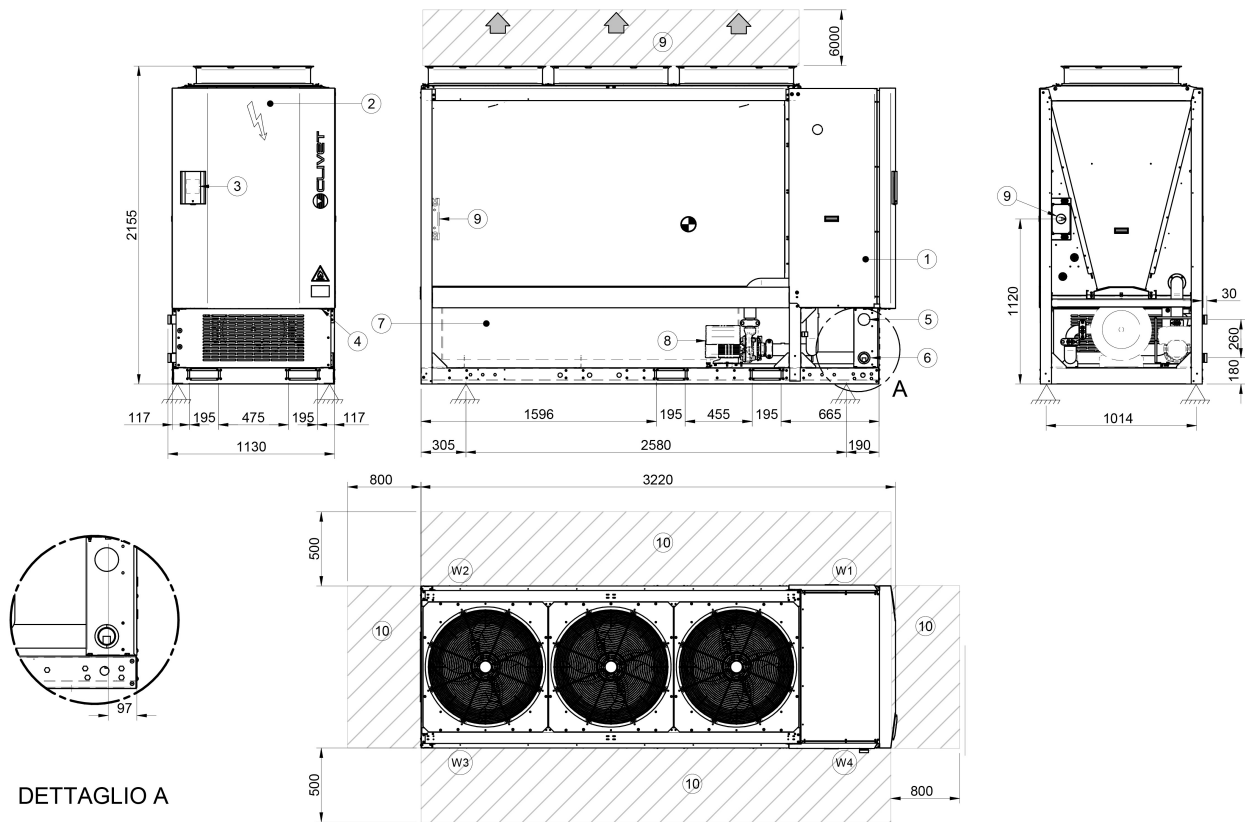

1. Compressor compartment
2. Electrical panel
3. Control keypad
4. Power input
5. Water inlet 2" Victaulic
6. Water outlet 2" Victaulic
7. Water tank**
8. Pump**
9. Isolating switch**
10. Functional spaces

**Optional

SIZE		25.2	30.2	35.2
Lenght	mm	3220	3220	3220
Depth	mm	1130	1130	1130
Height	mm	2155	2155	2155
Operating weight	kg	725	725	725
Shipping weight	kg	710	710	710
Weight with water tank	kg	805	805	805
Shipping weight with water tank	kg	1093	1093	1093

The presence of optional accessories may result in a substantial variation of the weights shown in the table.

FOR OVER 30 YEARS, WE HAVE BEEN
OFFERING SOLUTIONS TO ENSURE
SUSTAINABLE COMFORT AND THE WELL-
BEING OF PEOPLE AND THE ENVIRONMENT



sales and assistance

www.clivet.com



CLIVET SPA

Via Camp Lonc 25, Z.I. Villapaiera

32032 Feltre (BL) - Italy

Tel. +39 0439 3131 - Fax +39 0439 313300

info@clivet.it

MideaGroup
humanizing technology