



# WSHN-XEE2 MF

12.2 - 80.2



**MANUAL**  
FOR INSTALLATION,  
USE AND MAINTENANCE

Dear Customer,

We congratulate you on choosing this product

For many years Clivet has been offering systems that provide maximum comfort, together with high reliability, efficiency, quality and safety.

The aim of the company is to offer advanced systems, that assure the best comfort, reduce energy consumption and the installation and maintenance cost for the life cycle of the system.

The purpose of this manual is to provide you with information that is useful from reception of the equipment, through installation, operational usage and finally disposal so that this advanced system offers the best solution.

Yours faithfully,

CLIVET Spa

The data contained in this manual is not binding and may be changed by the manufacturer without prior notice.

Reproduction, even in part, is FORBIDDEN © Copyright - CLIVET S.p.A. - Feltre (BL) - Italia

---

# Index of contents

|    |                        |    |
|----|------------------------|----|
| 1  | General description    | 4  |
| 2  | Reception              | 6  |
| 3  | Positioning            | 8  |
| 4  | Water connections      | 9  |
| 5  | Electrical connections | 12 |
| 6  | Start-up               | 18 |
| 7  | Control                | 28 |
| 8  | Maintenance            | 40 |
| 9  | Accessories            | 44 |
| 10 | Decommissioning        | 50 |
| 11 | Residual risks         | 51 |
| 12 | Technical information  | 52 |
| 13 | Dimensional drawings   | 60 |

# 1 General description

## 1.1 Manual

The manual provides correct unit installation, use and maintenance.

Pay particular attention to:



Warning, identifies particularly important operations or information.



Prohibited operations that must not be carried out, that compromise the operating of the unit or may cause damage to persons or things.

- It is advisable to read it carefully so you will save time during operations.
- Follow the written indications so you will not cause damages to things and injuries people.

## 1.2 Preliminaries

Only qualified personnel can operate on the unit, as required by the regulation in force.

## 1.3 Risk situations



The unit has been designed and created to prevent injuries to people.

During designing it is not possible to plane and operate on all risk situation.

Read carefully "Residual risk" section where all situation which may cause damages to things and injuries to people are reported.

Installation, starting, maintenance and repair required specific knowledge; if they are carried out by inexperienced personnel, they may cause damages to things and injuries people.

## 1.4 Intended use

Use the unit only:

- for cooling/heating water or a water and glycol mix
- keep to the limits foreseen in the technical schedule and in this manual

The manufacturer accepts no responsibility if the equipment is used for any purpose other than the intended use.

## 1.5 Installation

Outdoor installation



The positioning, hydraulic system, refrigerating, electrics and the ducting of the air must be determined by the system designer in accordance with local regulations in force.

Follow local safety regulations.

Verify that the electrical line characteristics are in compliance with data quotes on the unit serial number label.

## 1.6 Maintenance

Plan periodic inspection and maintenance in order to avoid or reduce repairing costs.



Turn the unit off before any operation.

## 1.7 Modification



All unit modifications will end the warranty coverage and the manufacturer responsibility.

## 1.8 Breakdown/Malfuction

Disable the unit immediately in case of breakdown or malfunction.

Contact a certified service agent.

Use original spares parts only.

Using the unit in case of breakdown or malfunction:

- voids the warranty
- it may compromise the safety of the unit
- may increase time and repair costs

## 1.9 User training



The installer has to train the user on:

- Start-up/shutdown
- Set points change
- Standby mode
- Maintenance
- What to do / what not to do in case of breakdown

## 1.10 Data update

Continual product improvements may imply manual data changes.

Visit manufacturer web site for updated data.

## 1.11 Indications for the User



Keep this manual with the wiring diagram in an accessible place for the operator.

Note the unit data label so you can provide them to the assistance centre in case of intervention (see "Unit identification" section).

Provide a unit notebook that allows any interventions carried out on the unit to be noted and tracked making it easier to suitably note the various interventions and aids the search for any breakdowns.

In case of breakdown or malfunction:

- Immediately deactivate the unit
- Contact a service centre authorized by the manufacturer



The installer must train the user, particularly on:

- Start-up/shutdown
- Set points change
- Standby mode
- Maintenance
- What to do / what not to do in case of breakdown

## 1.12 Unit identification

The serial number label is positioned on the unit and allows to identify all the unit features.

The matriculation plate shows the indications foreseen by the standards, in particular:

- unit type
- serial number (12 characters)
- year of manufacture
- wiring diagram number
- electrical data
- type of refrigerant
- refrigerant charge
- manufacturer logo and address



The matriculation plate must never be removed.



It contains fluorinated greenhouse gases

Type of refrigerant: R410A

## 1.13 Serial number

It identifies uniquely each unit.

Must be quoted when ordering spare parts.

## 1.14 Assistance request

Note data from the serial number label and write them in the chart on side, so you will find them easily when needed.

|                           |
|---------------------------|
| Series                    |
| Size                      |
| Serial number             |
| Year of manufacture       |
| Electrical wiring diagram |

## 2 Reception



You have to check before accepting the delivery:

- That the unit hasn't been damaged during transport
- That the materials delivered correspond with that indicated on the transport document comparing the data with the identification label positioned on the packaging.

In case of damage or anomaly:

- Write down on the transport document the damage you found and quote this sentence: "Conditional acceptance clear evidence of deficiencies/damages during transport"
- Contact by fax and registered mail with advice of receipt to supplier and the carrier.



Any disputes must be made within 8 days from the date of the delivery. Complaints after this period are invalid.

### 2.1 Storage

Observe external packaging instructions.

### 2.2 Handling

1. Verify unit weight and handling equipment lifting capacity.
2. Identify critical points during handling (disconnected routes, flights, steps, doors).
3. Suitably protect the unit to prevent damage.
4. lifting brackets
5. Lifting with balance
6. Lifting with spacer bar
7. Align the barycenter to the lifting point
8. Use all the lifting brackets (see the dimensional section)
9. Gradually bring the lifting belts under tension, making sure they are positioned correctly.
10. Before starting the handling, make sure that the unit is stable.

1



2

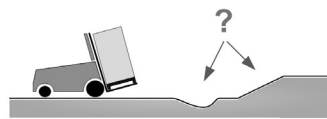

3

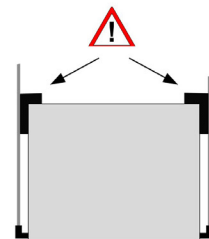

4

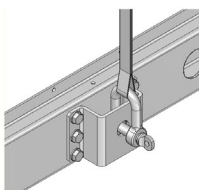

5

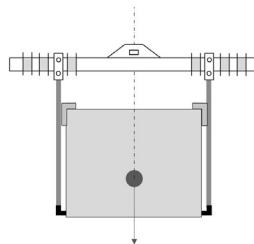

6

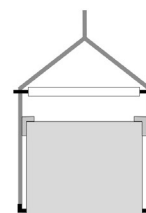

## 2.3 Packaging removing

Be careful not to damage the unit.

Keep packing material out of children's reach it may be dangerous.

Recycle and dispose of the packaging material in conformity with local regulations.

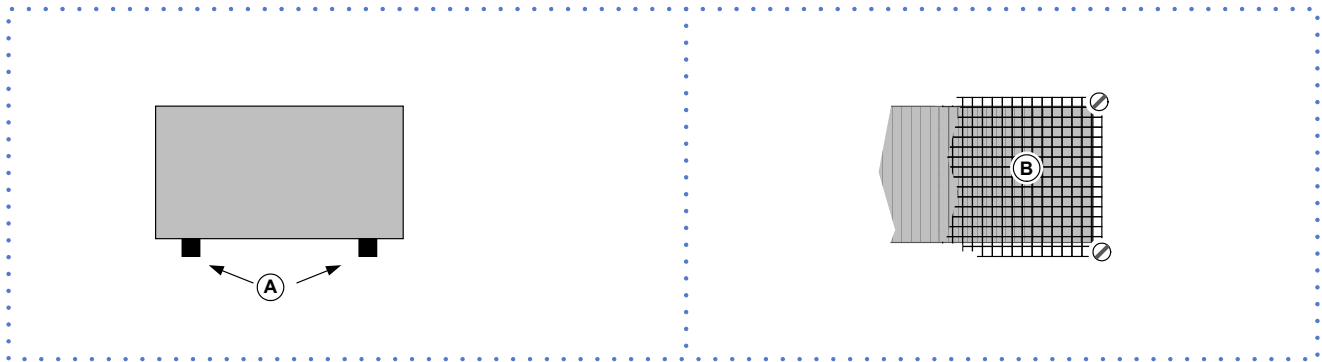

- A Supports for handling: remove after the handling.
- B Remove the coil protective mesh before the start-up

## 3 Positioning

During positioning consider these elements:

- Technical spaces requested by the unit
- Electrical connections
- Water connections
- Spaces for air exhaust and intake

### 3.1 Functional spaces

Functional spaces are designed to:

- guarantee good unit operation
- carry out maintenance operations
- protect authorized operators and exposed people

Respect all functional spaces indicated in the DIMENSIONS section.

Double all functional spaces if two or more unit are aligned.

### 3.2 Positioning



Units are designed to be installed:

- INTERNAL
- in fixed positions

Limit vibration transmission:

- use antivibration devices on unit bearing points
- install flexible joints on the hydraulic connections

Choose the installation place according to the following criteria:

- Customer approval
- safe accessible position
- technical spaces requested by the unit
- max. distance allowed by the electrical connections
- Avoid installations in places subject to flooding
- verify unit weight and bearing point capacity
- verify that all bearing points are aligned and leveled

### 3.3 Saftey valve gas side

The installer is responsible for evaluating the opportunity of installing drain tubes, in conformity with the local regulations in force (EN 378).

## 4 Water connections

### 4.1 Water quality

Water features

- confirming to local regulations
- total hardness < 14°fr
- within the limits indicated by table

The water quality must be checked by qualified personnel.

Water with inadequate characteristics can cause:

- pressure drop increase
- reduces energy efficiency
- increased corrosion potential

Acceptable water quality values:

|  |           |     |
|--|-----------|-----|
| PH   | 7,5 ÷ 9,0 |     |
| SO <sub>4</sub> <sup>2-</sup>                                | < 100     | ppm |
| HCO <sub>3</sub> <sup>-</sup> /SO <sub>4</sub> <sup>2-</sup> | > 1       |     |
| Total Hardness   | 4,5 ÷ 8,5 | dH  |
| Cl <sup>-</sup>  | < 50      | ppm |
| PO <sub>4</sub> <sup>3-</sup>                                | < 2,0     | ppm |
| NH <sub>3</sub>  | < 0,5     | ppm |

|                              |        |     |
|------------------------------|--------|-----|
| Free Chlorine                | < 0,5  | ppm |
| Fe <sub>3</sub> <sup>+</sup> | < 0,5  | ppm |
| Mn <sup>++</sup>             | < 0,05 | ppm |
| CO <sub>2</sub>              | < 50   | ppm |
| H <sub>2</sub> S             | < 50   | ppb |
| Temperature                  | < 65   | °C  |
| Oxygen content               | < 0,1  | ppm |

Provide a water treatment system if values fall outside the limits.



The warranty does not cover damages caused by limestone formations, deposits and impurities from the water supply and / or failure from failed system clearing to clean system.

### 4.2 Risk of freezing

If the unit or the relative water connections are subject to temperatures close to 0°C:

- mix water with glycol, or
- safeguard the pipes with heating cables placed under the insulation, or
- empty the system in cases of long non-use

### 4.3 Anti-freeze solution

The use of an anti-freeze solution results in an increase in pressure drop.



Make sure that the glycol type utilized is inhibited (not corrosive) and compatible with the water circuit components.



Do not use different glycol mixture (i.e. ethylene with propylene).

### 4.4 Water flow-rate

The project water-flow must be:

- inside the exchanger operating limits (see the TECHNICAL INFORMATION section)
- guarantee, also with variable system conditions (for example in systems where some circuits are bypassed in particular situations).

### 4.5 Hydraulic connections

- take away the supplied connection union by acting on the connection joint
- weld the union to the installation pipe
- perform the connection between the installation pipe and the evaporator, using the joint



Do not weld the system pipe with the Victaulic connection joint attached.



The rubber gasket might be irreparably damaged.

## 4.6 Recommended connection



The installer must define:

- component type
- position in system

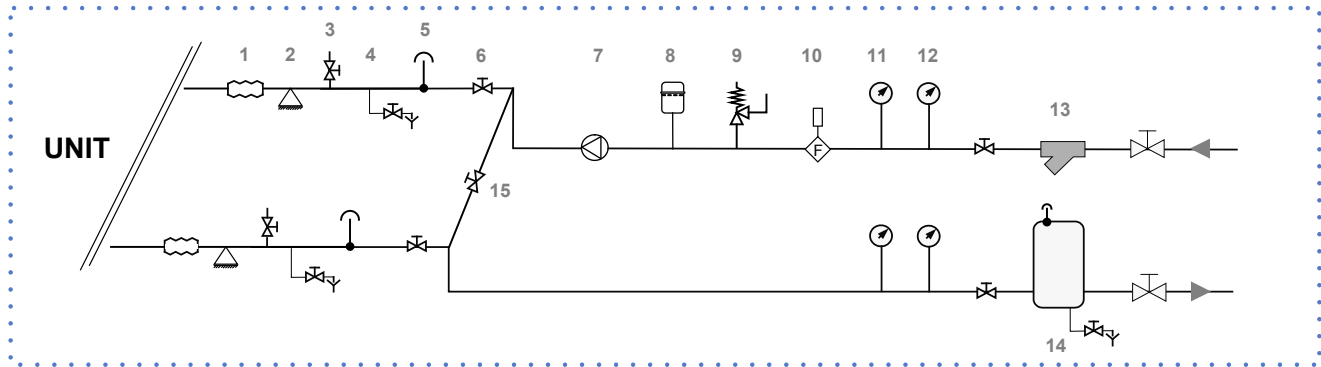

- |                                      |                           |
|--------------------------------------|---------------------------|
| 1 antivibration joints               | 9 safety valve            |
| 2 piping support                     | 10 Flow Switch            |
| 3 exchanger chemical cleaning bypass | 11 pressure gauge         |
| 4 drain valve                        | 12 thermometer            |
| 5 vent                               | 13 filter                 |
| 6 shut-off valve                     | 14 Internal storage tank  |
| 7 Pump / circulating pump            | 15 Cleaning system bypass |
| 8 expansion vessel                   |                           |

## 4.7 Water filter

Use filter with mesh pitch:

| Size        | Mesh pitch |
|-------------|------------|
| 12.2 - 22.2 | 0,5 mm     |
| 27.2 - 80.2 | 1,5 mm     |



It must be installed immediately in the water input of the unit, in a position that is easily accessible for cleaning.



The filter never should be removed, this operation invalidates the guaranty.

## 4.8 Flow Switch



The flow switch must be present to ensure shutdown of the unit if water is not circulating.

It has to be installed in a duct rectilinear part, not in proximity of curves that cause turbulences.

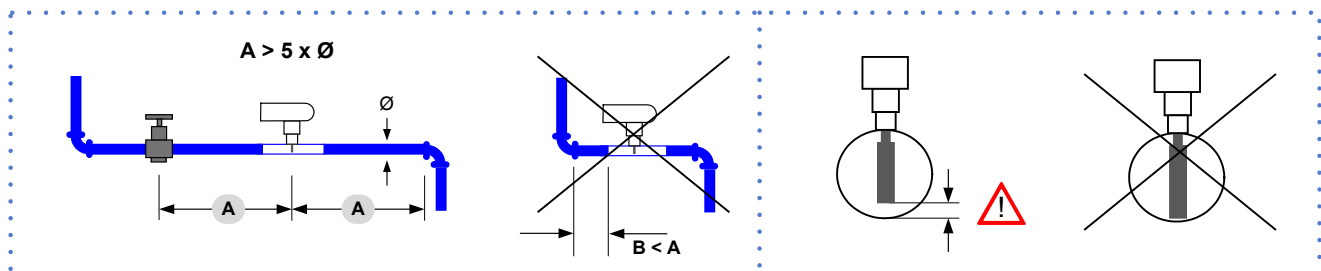

A. minimum distance

## 4.9 Operation sequence

Close all vent valves in the high points of the unit hydraulic circuit

Close all drain valves in the low points of the unit hydraulic circuit:

- Heat exchangers
  - Pumps
  - collectors
  - storage tank
  - free-cooling coil
1. Carefully wash the system with clean water: fill and drain the system several times.
  2. Apply additives to prevent corrosion, fouling, formation of mud and algae.
  3. Fill the plant
  4. Execute leakage test.
  5. Isolate the pipes to avoid heat dispersions and formation of condensate.
  6. Leave various point of service free (wells, vent-holes etc).



Neglecting the washing will lead to several filter cleaning interventions and at worst cases can cause damages to the exchangers and the other parts.

## 4.10 hydronic assembly

For details see:

9 Accessories p. 44

## 4.11 VALVE FOR DOMESTIC HOT WATER

For details see:

9 Accessories p. 44

## 4.12 NATURAL COOLING function

For details see:

9.7 NATURAL COOLING function p. 49

## 4.13 Energy recovery

Option

A configuration which enables the production of hot water free-of-charge while operating in the cooling mode, thanks to the partial recovery of condensation heat that would otherwise be rejected to the external heat source.

The maximum capacity available from the partial recovery is equal to the 15% of the rejected heating capacity (cooling capacity + compressor power input)



The recovery exchanger must be always maintained full of water

The lack of water amplifies the noise generated by the operation

When the temperature of the water to be heated is particularly low, it is wise to insert a flow-rate control valve into the system water circuit, in order to maintain the temperature at the recovery output at above 35°C and thus avoid the condensation of the refrigerant into the partial energy recovery device.

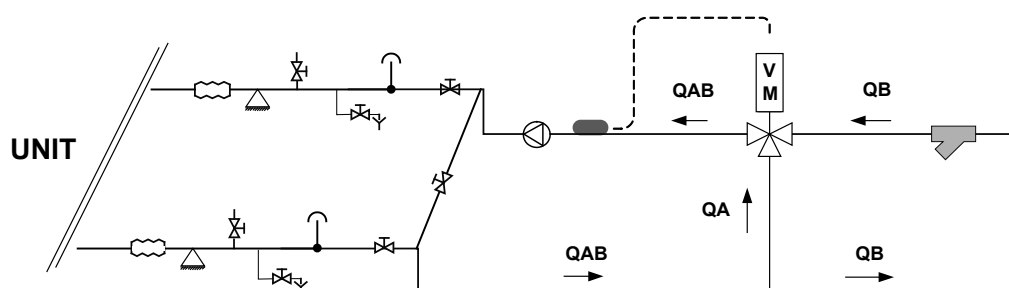

## 5 Electrical connections

The characteristics of the electrical lines must be determined by qualified electrical personnel able to design electrical installations; moreover, the lines must be in conformity with regulations in force.

The protection devices of the unit power line must be able to stop all short circuit current, the value must be determined in accordance with system features.

The power cables and the protection cable section must be defined in accordance with the characteristics of the protections adopted.

All electrical operations should be performed by trained personnel having the necessary qualifications required by the regulations in force and being informed about the risks relevant to these activities.

Operate in compliance with safety regulations in force.

### 5.1 Electrical data



The serial number label reports the unit specific electrical data, included any electrical accessories.

The electrical data indicated in the technical bulletin and in the manual refer to the standard unit, accessories excluded.

The matriculation plate shows the indications foreseen by the standards, in particular:

- Voltage
- F.L.A.: full load ampere, absorbed current at maximum admitted conditions
- F.L.I.: full load input, full load power input at max. admissible condition
- Electrical wiring diagram Nr.

### 5.2 Connections

1. Refer to the unit electrical diagram (the number of the diagram is shown on the serial number label).
2. Verify that the electrical supply has characteristics conforming to the data shown on the serial number label.
3. Before starting work, ensure the unit is isolated, unable to be turned on and a safety sign used.
4. Ensure correct earth connection.
5. Ensure cables are suitably protected.
6. Before powering up the unit, make sure that all the protections that were removed during the electrical connection work have been restored.

### 5.3 Signals / data lines

Do not exceed the maximum power allowed, which varies, according to the type of signal.

Lay the cables far from power cables or cables having a different tension and that are able to emit electromagnetic disturbances.

Do not lay the cable near devices which can generate electromagnetic interferences.

Do not lay the cables parallel to other cables, cable crossings are possible, only if laid at 90°.

Connect the screen to the ground, only if there aren't disturbances.

Guarantee the continuity of the screen during the entire extension of the cable.

Respect impedance, capacity and attenuation indications.

### 5.4 Power input



Fix the cables: if vacated may be subject to tearing.



The cable must not touch the compressor and the refrigerant piping (they reach high temperatures).

## 5.5 Connections performed by customer

|              | English                                 | Deutsch  | Español   | Italiano                                       | Français  |
|--------------|---|--|---|--|---|
| DEMAND LIMIT | demand limit                            | demand limit   | demand limit  | demand limit                                   | demand limit  |
| WATER RESET  | water reset                             | water reset  | water reset   | water reset                                    | water reset   |
| BTairExt     | outside air temperature probe           | Außenlufttemperaturfühler                            |   | sonda di temperatura aria esterna              | sonde de température air extérieur                        |
| YVNC         | natural-cooling 3-way valve             | 3-Wegeventil Natural-Cooling                         | válvula de 3 vías natural-cooling                     | valvola 3 vie natural-cooling                  | soupape 3-voies natural-cooling                           |
| YVNCM        | natural-cooling 3-way valve             | 3-Wegeventil Natural-Cooling                         | válvula de 3 vías natural-cooling                     | valvola 3 vie natural-cooling                  | soupape 3-voies natural-cooling                           |
| SA5          | remote winter/summer selector           | Fernwahlschalter Winter/Sommer                       | selector remoto "verano/invierno"                     | selettore remoto estate/inverno                | sélecteur déporté "été/hiver"                             |
| SA1          | remote on/off selector                  | Fernwahlschalter Ein/Aus                             | selector on/off remoto                                | selettore on/off remoto                        | sélecteur ON/OFF déporté                                  |
| SQS          | Source side exchanger flow switch       | Stromungswächler des Wärmeaustauschers Quelle/Seite  | Flujostato cambiador lado fuente                      | flussostato scambiatore lato sorgente          | Contôleur de débit de l'échangeur côté source             |
| SQU          | utility side exchanger flow switch      | Stromungswächler Wärmeaustauscher auf Verbrauchseite | flujostato intercambiador lado equipo                 | flussostato scambiatore lato utilizzo          | Contôleur de débit échangeur côté utilisateur             |
| SQR          | Flow switch for heat recovery exchanger | Stromungswächler Rückgewinnung                       | Flujostato por intercambiador a recuperación de calor | Flussostato per scambiatore recupero di calore | Contôleur de débit pour échangeur récupération de chaleur |
| CU           | use call                                | Verbrauchsanruf                                      | llamada al utilización                                | Chiamata utilizzo                              | appel utilisation   |
| CR           | remote heat recovery enabling selector  | Fernwahlschalter Rückgewinnung                       | selector remoto de habilitación para la recuperación  | selettore remoto di abilitazione al recupero   | sélecteur déporté de validation récupération              |
| SA-ACS       | sanitary water cycle selector           | Wahlschalter der Brauchwasser                        | selector solicitud agua sanitario                     | selettore richiesta acqua sanitaria            | sélecteur demande eau sanitaire                           |
| SA1.1        | second set-point enabling switch        | Wahlschalter 2.Sollwert                              | selector habilitación segundo set-point               | selettore abilitazione secondo set-point       | sélecteur validation deuxième consigne                    |
| ACS          | valve ACS                               | Hahn ACS   | Valvula de ACS  | valvola ACS                                    | Valve ACS   |

collegamenti a cura del cliente  
 connections performed by customer  
 raccordements à la charge du client  
 kundenseitige Anschlüsse  
 conexiones a cargo del cliente

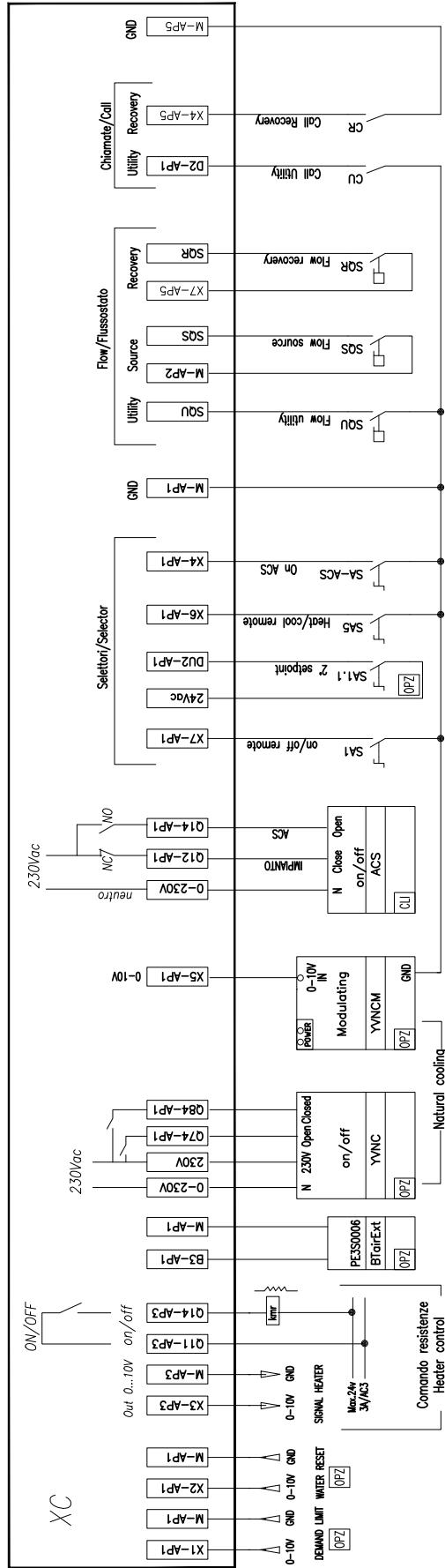

## 5.6 Computer connection

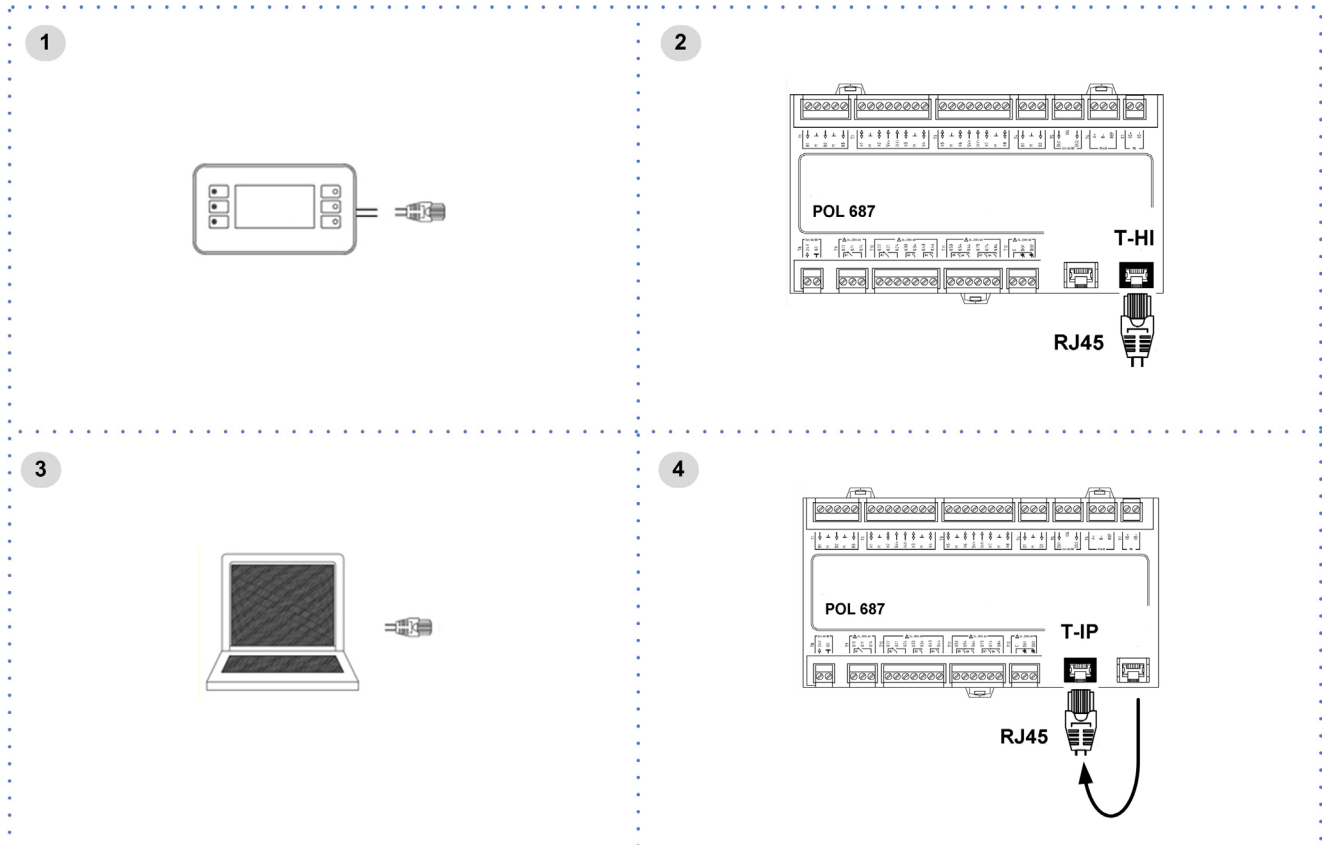

1. Service keypad
2. RJ45: standard connection
3. P.C.-not supplied
4. P.C. connection, shift RJ45 from T-HI to T-IP

### Configure P.C.

1. connect P.C. and main module with LAN cable
2. check in the taskbar that the connection is active
3. open Control Panel and select Network and sharing center
4. select Modify board setting
5. select Local area connection (LAN)
6. select Internet protocol version 4 (TPC) IPV4 and enter Property
7. set the IP address 192.168.1.100
8. set Subnet mask as 255.255.255.0
9. confirm (OK)
10. enter Start (Windows button)
11. write the command cmd and enter/do it
12. write and run the command Ping 192.168.1.42
13. the message, connection is OK, will appear when successful
14. enter the browser (Chrome, Firefox ecc)
15. write and run the command http://192.168.1.42
16. Userid = WEB
17. Password = SBTAdmin!

## 5.7 Remote control

Option

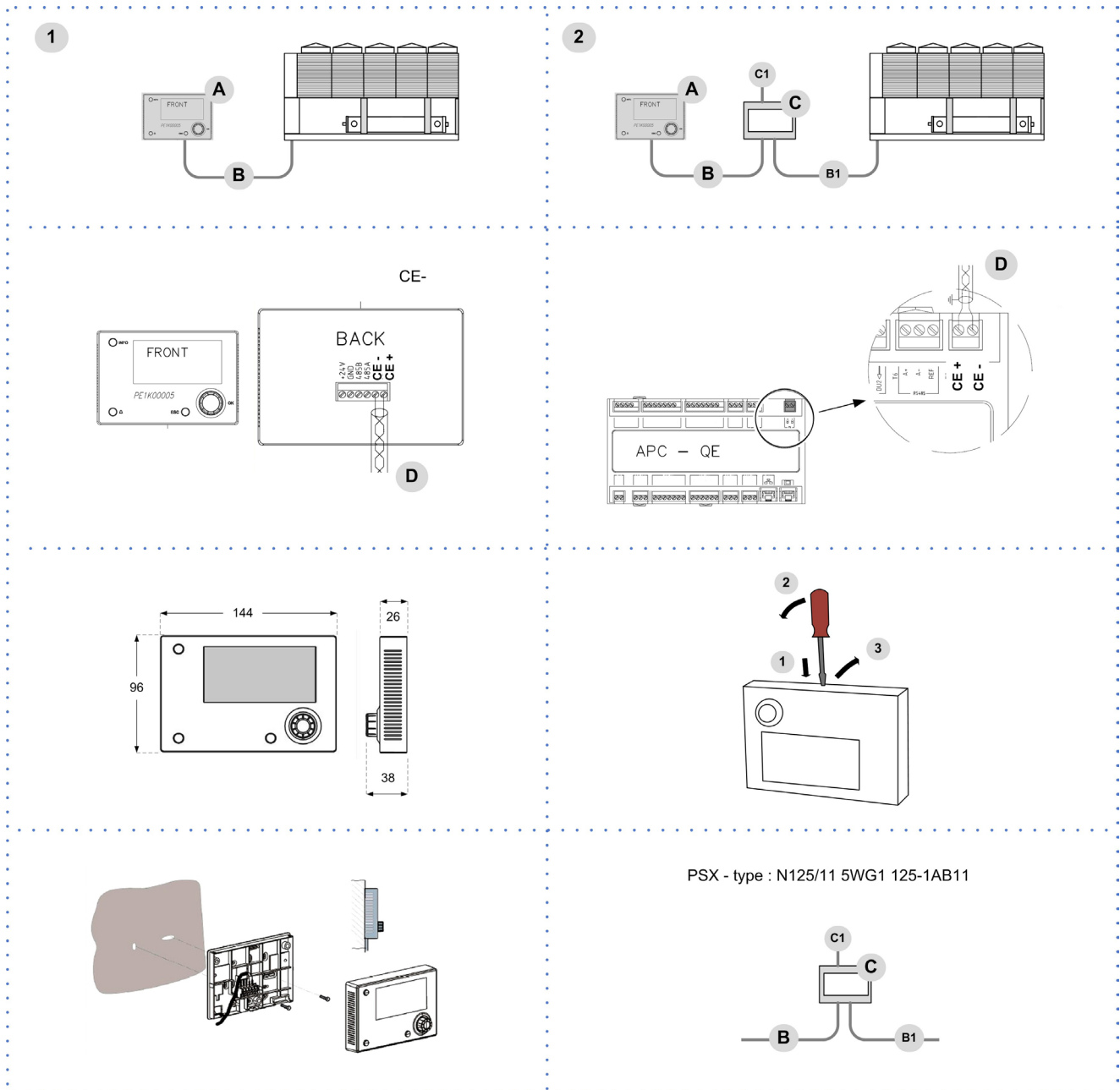

- 1 Distance up to 350 mt
- 2 Distance up to 700 mt

- A User interface
- B = B1 KNX bus, max 350 mt  
twisted pair with shield,  $\varnothing$  0,8 mm  
EIB/KNX cable marking recommende
- C PSX - Mains power supply unit  
pwer supply unit N125/11 5WG1 125-1AB11
- C1 AC 120...230V, 50...60Hz
- D KNX bus, max 350 mt

## 5.8 Modbus - RS485

Option

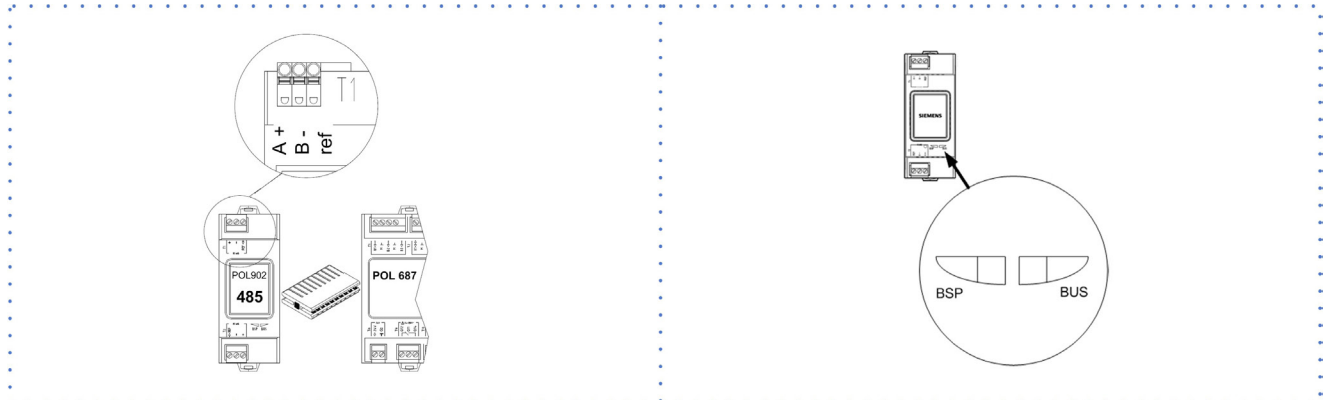

LED BSP  
 green communication with AP1 module  
 communication ok  
 yellow software ok but communication with AP1 down  
 red flashing: software error  
 fixed: hardware error

LED BUS  
 green communication with Modbus  
 communication ok  
 yellow startup / channel not communicating  
 red communication down

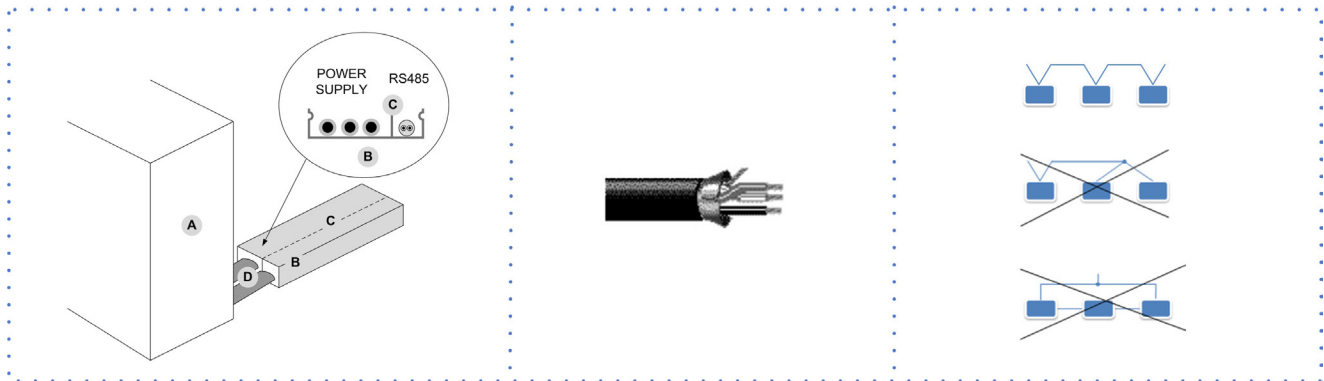

- A. Unit
- B. Metal conduit
- C. Metal septums
- D. Metal-lined sheath (sleeve)

### Modbus / LonWorks / BACnet Cable requirements

Couple of conductors twisted and shielded

Section of conductor 0,22mm<sup>2</sup>...0,35mm<sup>2</sup>

Rated power between conductors <math>\leq 50 \text{ pF/m}</math>

Nominal impedance 120  $\Omega$

Recommended cable BELDEN 3106A

- Every RS485 serial line must be set up using the 'In/Out' bus system.
- Other types of networks are not allowed, such as Star or Ring networks.
- The difference in potential between the earth of the two RS485 devices that the cable shielding needs to be connected to must be lower than 7 V
- There must be suitable arresters to protect the serial lines from the effects of atmospheric discharges
- A 120 ohm resistance must be located on the end of the serial line. Alternatively, when the last serial board is equipped with an internal terminator, it must be enabled using the specific jumper, dip switch or link.
- The cable must have insulation features and non-flame propagation in accordance with applicable regulations.
- The RS485 serial line must be kept as far away as possible from sources of electromagnetic interference.

## 5.9 LonWorks

Option

**LonWorks**

**LONWORK CABLE TYPE**  
Echelon allows three cable types for channel type TP/FT-10, including the Category 5 network cable used commonly in building automation and control (TIA 568A Cat-5).

**CAT-5 SPECIFICATIONS**  
Unshielded cable, twisted pair with at least 18 beats per meter:

- Cross-sectional area Min.  $\varnothing$  0.5mm, AWG24, 0.22mm<sup>2</sup>
- Impedance 100 +/- 15% @ f > 1 MHz
- Operating capacity between two wires of a pair < 46 nF/km
- Capacity pair to ground, asymmetric. < 3.3 nF/km
- DC loop resistance < 168  $\Omega$

|         |   |
|---------|---|
| LED BSP | communication with AP1 module               |
| green   | communication ok                            |
| yellow  | software ok but communication with AP1 down |
| red     | flashing: software error                    |
|         | fixed: hardware error                       |

|         |                                      |
|---------|--------------------------------------|
| LED BUS | communication with LonWorks          |
| green   | ready for communication              |
| yellow  | startup                              |
| red     | flashing: communicating not possible |
|         | communication down                   |

## 5.10 BACnet IP

Option

**BACnet**

Ethernet 10/100 Mbit (IEEE 802.3U)  
Cable connection RJ45 jack, 8 pins

|         |   |
|---------|---|
| LED BSP | communication with AP1 module               |
| green   | communication ok                            |
| yellow  | software ok but communication with AP1 down |
| red     | flashing: software error                    |
|         | fixed: hardware error                       |

|         |                           |
|---------|---------------------------|
| LED BUS | communication with BACnet |
| green   | ready for communication   |
| yellow  | startup                   |
| red     | BACnet server down        |
|         | restart after 3 sec       |

## 6 Start-up

### 6.1 General description

The indicated operations should be done by qualified technician with specific training on the product.

The electrical, water connections and the other system works are by the installer.

Upon request, the service centres performing the start-up.

Agree upon in advance the start-up data with the service centre.

For details refer to the different manual sections.

Before checking, please verify the following:

- the unit should be installed properly and in conformity with this manual
- the electrical power supply line should be isolated at the beginning
- the unit isolator is open, locked and equipped with the suitable warning
- make sure no tension is present



After turning off the power, wait at least 5 minutes before accessing to the electrical panel or any other electrical component.



Before accessing check with a multimeter that there are no residual stresses.

### 6.2 Preliminary checks

#### Unit OFF power supply

1. safety access
2. functional spaces
3. structure integrity
4. unit on vibration isolators
5. unit input water filter + shut-off valves for cleaning
6. vibration isolators on water connections
7. expansion tank (indicative volume = 5% system content)
8. minimum system water content
9. cleaned system
10. loaded system + possible glycol solution + corrosion inhibitor
11. system under pressure
12. vented system
13. refrigerant circuit visual check
14. earthing connection
15. power supply features
16. electrical connections provided by the customer

### 6.3 Start-up sequence

Unit ON power supply

1. compressor crankcase heaters operating at least since 8 hours
2. off-load voltage measure
3. phase sequence check
4. pump manual start-up and flow check
5. shut-off valve refrigerant circuit open
6. unit ON
7. load voltage measure and absorptions
8. liquid sight glass check (no bubbles)
9. measure return and supply water temperature
10. measure super-heating and sub-cooling
11. check no anomalous vibrations are present
12. climatic curve personalization
13. climatic curve personalization
14. scheduling personalization
15. complete and available unit documentation

## 6.4 Configuration for 2-pipe system

To ensure correct operation of the unit, the latter must be equipped with a flow-rate control device on the source side.

System cooling only (1)

In this condition, all the cooling capacity is released to the user side of the heat exchanger

The maintenance of the user side set point is ensured through the modulation of the capacity steps.

All the heating capacity is dispersed on the source exchanger

System cooling requirements and free production of domestic hot water (2)

In this condition, all the cooling capacity is released to the user side of the heat exchanger

All the heating capacity is released to the recovery side of the heat exchanger.

The capacity steps are modulated so as to guarantee a constant set point on the priority side chosen by the user.

System heating only (3)

In this condition all the heating capacity is released to the user side of the heat exchanger.

The maintenance of the user side set point is ensured through the modulation of the capacity steps.

All the cooling capacity is dispersed on the source exchanger.

System heating requirements and production of domestic hot water (4)

In this condition, the heat is released at the same time to the user side and the recovery side of the heat exchanger.

The total heating capacity that can be provided to the two points of use cannot exceed 100% of the unit's nominal heating capacity.

The unit will manage the capacity steps considering both loads and through modulation of the flow-rate it will initially satisfy the primary point of use, reserving the residual capacity for the secondary point of use.

All the cooling capacity is dispersed on the source exchanger.

Requirement for the production of domestic hot water only (5)

In this condition all the heating capacity is released to the recovery side of the heat exchanger.

The load requirements are met through the modulation of the capacity steps.

All the cooling capacity is dispersed on the source exchanger.

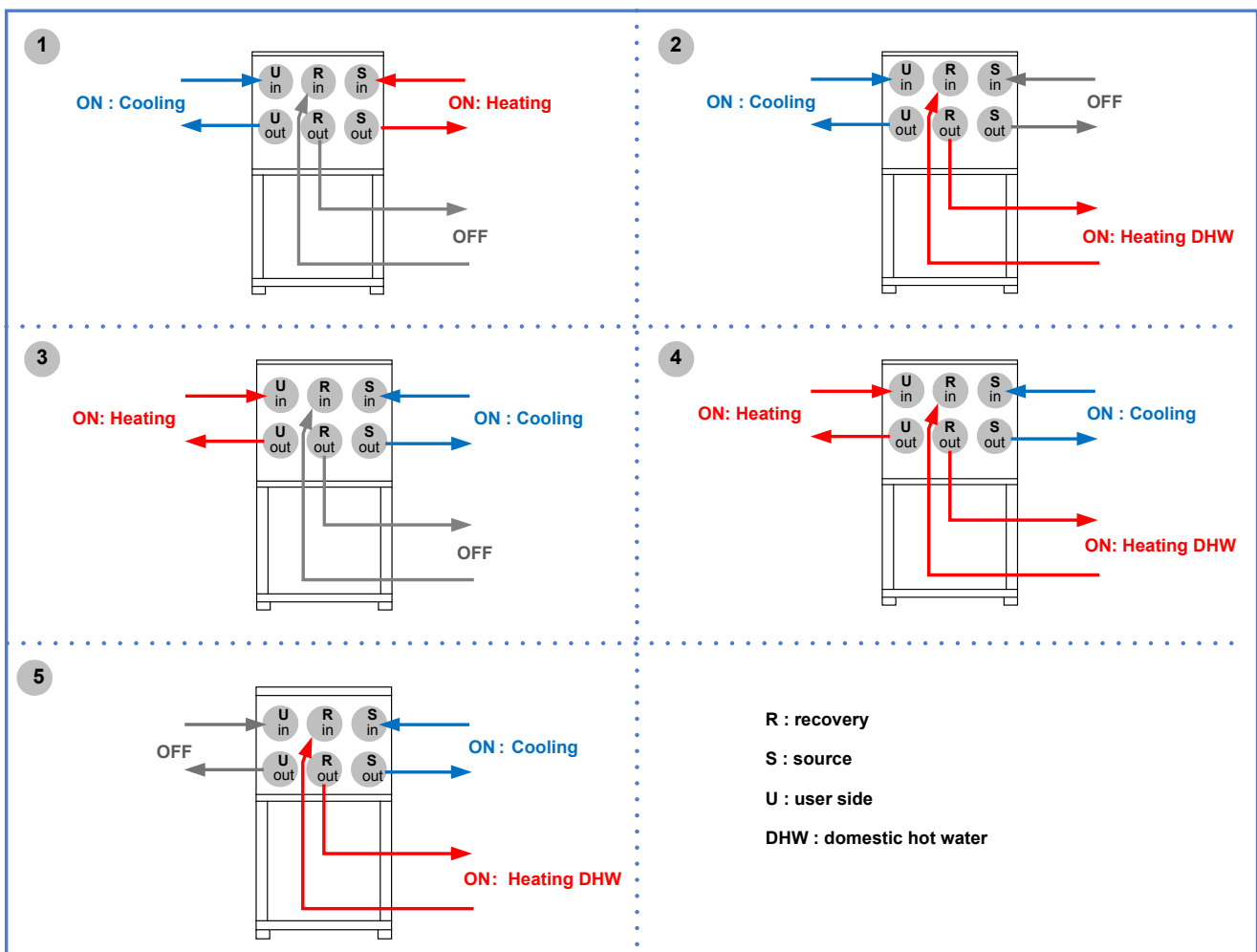

## 6.5 Configuration for 4-pipe system

Cooling requirement 100%, Heating requirement 0% (1)

In this condition, all the cooling capacity is released to the cooling side of the heat exchanger.

The maintenance of the cooling side set point is ensured through the modulation of the capacity steps.

All the heating capacity is dispersed on the source exchanger.

The pump control on the heating side may be activated or deactivated based on a schedule to keep water temperature under control.

Cooling requirement 0%, Heating requirement 100% (2)

In this condition all the heating capacity is released to the heating side of the heat exchanger.

The maintenance of the heating side set point is ensured through the modulation of the capacity steps.

All the cooling capacity is dispersed on the source exchanger.

Cooling capacity is not released on the cooling side: the cooling side pump control may be kept activated at a minimum or it may be activated and deactivated based on a regular schedule to keep water temperature under control.

Cooling requirement 100%, Heating requirement 100% (3)

In this condition all the cooling capacity is released to the user side of the heat exchanger and all the heating capacity is released to the heating side of the heat exchanger.

Maintenance of the heating side/cooling side set point is ensured through the modulation of the capacity steps, according to the operation mode used (heating side in winter operation, cooling side in summer operation).

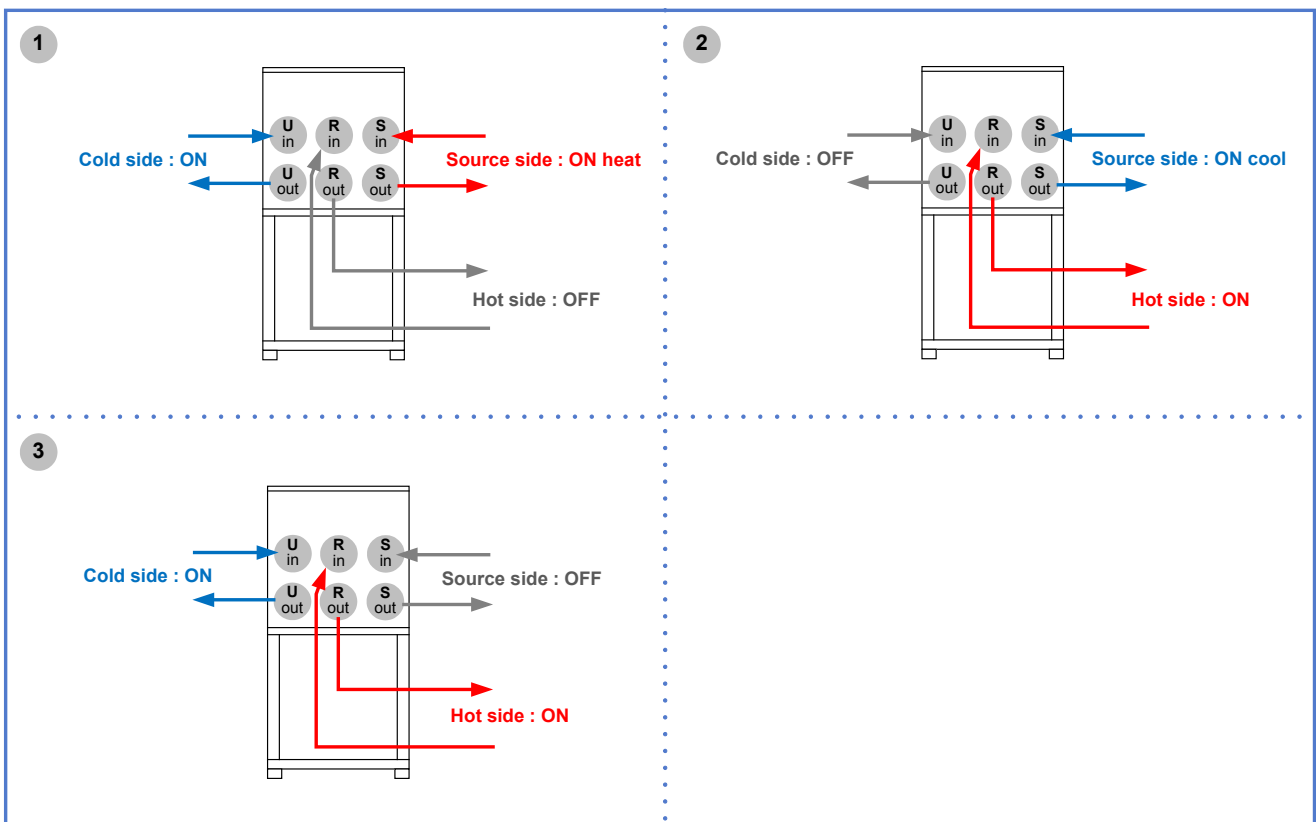

## 6.6 Refrigeration circuit

1. Check carefully the refrigerating circuit: the presence of oil stains can mean leakage caused by transportation, movements or other).
2. Verify that the refrigerating circuit is in pressure: Using the unit manometers, if present, or service manometers.
3. Make sure that all the service outlets are closed with proper caps; if caps are not present a leak of refrigerant can be possible.
4. Open the valves of the refrigerant circuit, if there are any.

## 6.7 Water circuit

1. Before realizing the unit connection make sure that the hydraulic system has been cleaned up and the cleaning water has been drained.
2. Check that the water circuit has been filled and pressurized.
3. Check that the shut-off valves in the circuit are in the "OPEN" position.
4. Check that there isn't air in the circuit, if required, evacuate it using the air bleed valve placed in the system high points.
5. When using antifreeze solutions, make sure the glycol percentage is suitable for the type of use envisaged.



Neglecting the washing will lead to several filter cleaning interventions and at worst cases can cause damages to the exchangers and the other parts.

| Weight of glycol (%)      | 10   | 20   | 30    | 40    |
|---------------------------|------|------|-------|-------|
| Freezing temperature (°C) | -3.9 | -8.9 | -15.6 | -23.4 |
| Safety temperature (°C)   | +1   | -4   | -10   | -19   |

## 6.8 Electric Circuit



Verify that the unit is connected to the ground plant.

Check the conductors are tightened as: the vibrations caused by handling and transport might cause these to come loose.

Connect the unit by closing the sectioning device, but leave it on OFF.

Check the voltage and line frequency values which must be within the limits: 400/3/50 +/- 10%

Check and adjust the phase balance as necessary: it must be lower than 2%

Example

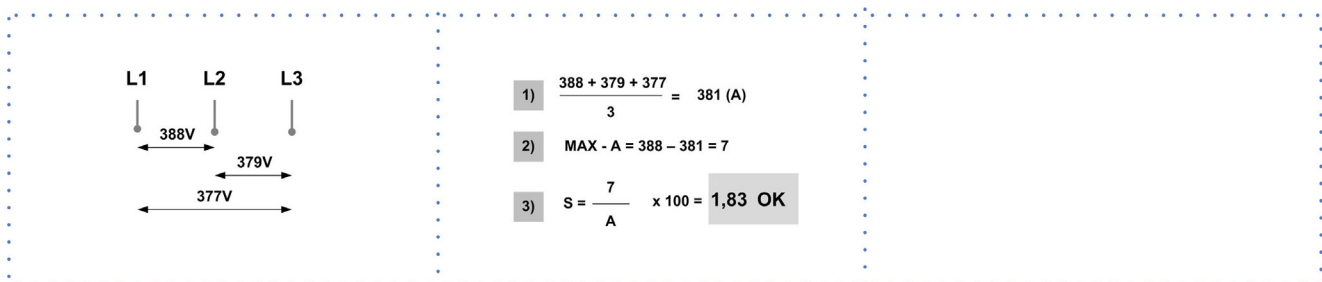

Working outside of these limits can cause irreversible damages and voids the warranty.

## 6.9 Compressor crankcase heaters

Connect the oil resistances on the compressor crankcase at least 8 hours before the compressor is to be started:

- at the first unit start-up
  - after each prolonged period of inactivity
1. Supply the resistances switching off the unit isolator switch.
  2. To make sure that heaters are working, check the power input.
  3. At start-up the compressor crank-case temperature on the lower side must be higher at least of 10°C than the outside temperature.



Do not start the compressor with the crankcase oil below operating temperature.

## 6.10 Remote controls

Check that the remote controls (ON-OFF etc) are connected and, if necessary, enabled with the respective parameters as indicated in the "electrical connections" section.

Check that probes and optional components are connected and enabled with the respective parameters ("electrical connections" section and following pages).

## 6.11 Voltages

Check that the air and water temperatures are within in the operating limits.

Start-up the unit.

With unit operating in stable conditions, check:

- Voltage
- Total absorption of the unit
- Absorption of the single electric loads

## 6.12 Demand limit

⚠ Menu accessible only after having entered the password.

⚠ Access reserved only to specifically trained personnel.

⚠ The parameter modification can cause irreversible damages.

It is possible to limit the absorbed electric power with an external signal 0-10 Vcc.

The higher the signal is, the lower the number of compressors available to meet the thermal need.

If only P0002: EnDemandLimit ≠ 0

Path: Main Menu / Unit parameters / Demand limit

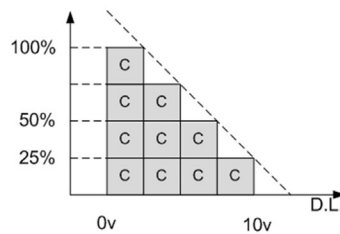

| Step | Display         | Action       | Menu/Variable     | Keys |   | Notes |
|------|-----------------|--------------|-------------------|------|---|-------|
| 1    |                 | Press 3 sec. |                   | ✓    |   |       |
| 2    | Password        | Set          | Password          | ▲    | ✓ |       |
| 3    |                 | Press        |                   | i    |   |       |
| 4    | Main menu       | Select       | Unit parameters   | ▼    | ✓ |       |
| 5    | Unit parameters | Select       | Set Point         | ▼    | ✓ |       |
| 6    | Set Point       | Select       | Demand limit      | ▼    | ✓ |       |
| 7    |                 | Set          | Demand limit      | ▲    | ▼ |       |
| 8    |                 | Confirm      |                   | ✓    |   |       |
| 9    |                 | Press 3 sec. |                   | ⏏    |   |       |
| 10   |                 | Select       | Local connections | ✓    |   |       |

Path: Main Menu / Unit parameters / Demand limit

| Parameters | Short description   | Description                                      |
|------------|---------------------|--|
| P0200      | setpointdemandlimit | Parameter setting of the value % of demand limit |

## 6.13 Climatic Text

Function allows the automatic regulation of the preset set-point depending of the outside temperature air measured by the unit probe.

The setpoint defined by the temperature curve is shown at status S0052: ActualUtSetp

Only if P0036: EnCompExt ≠ 0

Path: Main Menu / Unit parameters / TExt Correction config

- Menu accessible only after having entered the password.
  - Access reserved only to specifically trained personnel.
  - The parameter modification can cause irreversible damages.
- Example

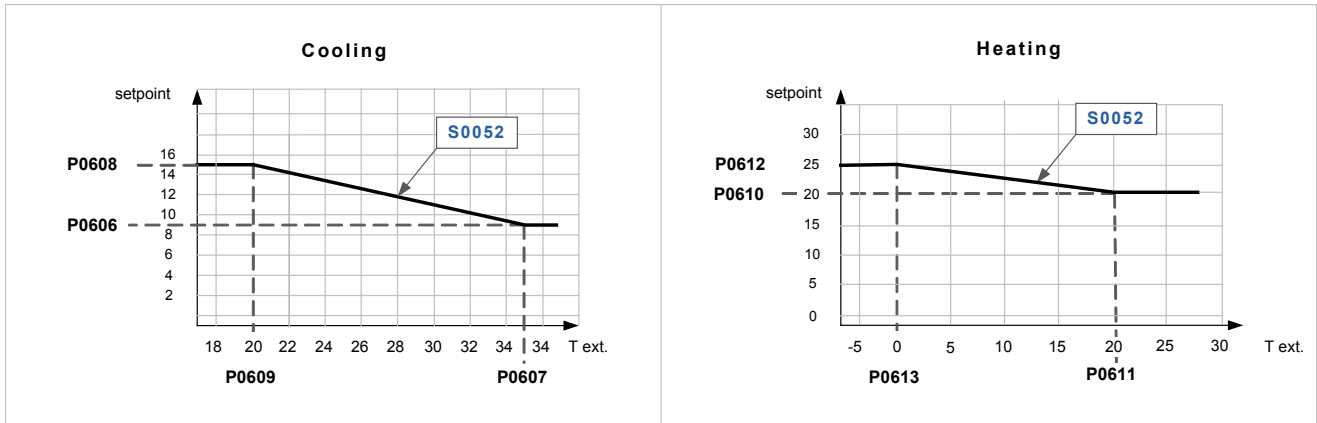

| Step | Display             | Action       | Menu/Variable     | Keys |  | Notes |
|------|---------------------|--------------|-------------------|------|--|-------|
| 1    |                     | Press 3 sec. |                   |      |  |       |
| 2    | Password            | Set          | Password          |      |  |       |
| 3    |                     | Press        |                   |      |  |       |
| 4    | Main menu           | Select       | Unit parameters   |      |  |       |
| 5    | Unit parameters     | Select       | Climatic TExt     |      |  |       |
| 6    | Climatic TExt (pwd) | Select       | Parameter         |      |  |       |
| 7    |                     | Set          |                   |      |  |       |
| 8    |                     | Confirm      |                   |      |  |       |
| 9    |                     | Press 3 sec. |                   |      |  |       |
| 10   |                     | Select       | Local connections |      |  |       |

Path: Main Menu / Unit parameters / TExt Correction config

| Parameters | Short description  | Description   |
|------------|--------------------|---|
| P0606      | CSptLow            | setpoint temperature value when the air temperature value is AirAtSptLowC                         |
| P0607      | AirAtSetPointLowC  | external air temperature value where the calculated setpoint takes on the value given by CSptLow  |
| P0608      | CSptHigh           | setpoint temperature value when the air temperature value is AirAtSptHigC                         |
| P0609      | AirAtSetPointHighC | external air temperature value where the calculated setpoint takes on the value given by CSptHigh |
| P0610      | HSptLow            | setpoint temperature value when the air temperature value is AirAtSptLowH                         |
| P0611      | AirAtSptLowH       | external air temperature value where the calculated setpoint takes on the value given by HSptLow  |
| P0612      | HSptHigh           | setpoint temperature value when the air temperature value is AirAtSptHighH                        |
| P0613      | AirAtSptHighH      | external air temperature value where the calculated setpoint takes on the value given by HSptHigh |

## 6.14 Water reset

- ⚠ Menu accessible only after having entered the password.
- ⚠ Access reserved only to specifically trained personnel.
- ⚠ The parameter modification can cause irreversible damages.  
The water reset correction affects the setpoint defined by the Climate curve TExt (actual setpoint).  
The setpoint is shown at status S0052: ActualUtSetp  
Only if P0003: En WaterReset ≠ 0  
Path: Main menu / Unit parameters / Water reset config

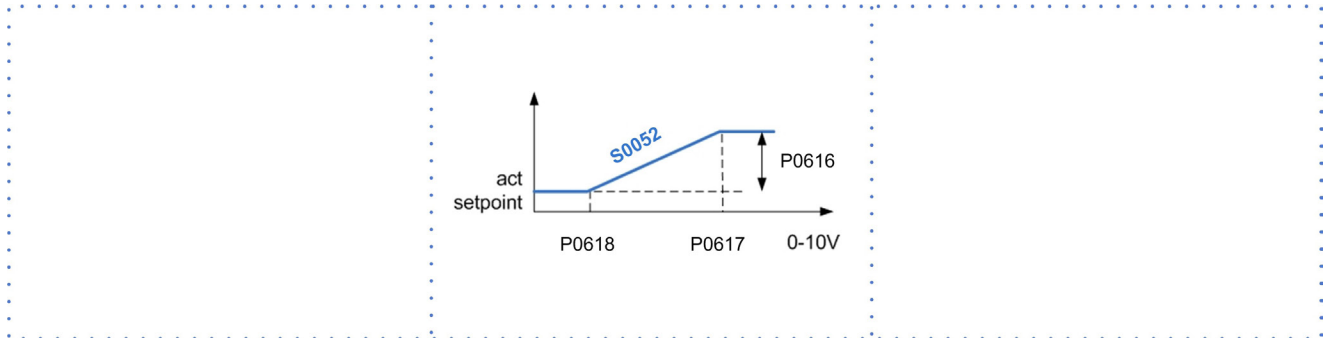

| Step | Display         | Action       | Menu/Variable     | Keys |   | Notes |
|------|-----------------|--------------|-------------------|------|---|-------|
| 1    |                 | Press 3 sec. |                   | ✓    |   |       |
| 2    | Password        | Set          | Password          | ▼    | ✓ |       |
| 3    |                 | Press        |                   | i    |   |       |
| 4    | Main menu       | Select       | Unit parameters   | ▼    | ✓ |       |
| 5    | Unit parameters | Select       | Water reset       | ▼    | ✓ |       |
| 6    | Water reset     | Select       | Parameter         | ▼    | ✓ |       |
| 7    |                 | Set          |                   | ▼    | ▲ |       |
| 8    |                 | Confirm      |                   | ✓    |   |       |
| 9    |                 | Press 3 sec. |                   | ⏏    |   |       |
| 10   |                 | Select       | Local connections | ✓    |   |       |

Path: Main Menu / Unit parameters / Water reset

| Parameters | Short description | Description  |
|------------|-------------------|--|
| P0616      | MaxCWRC           | Maximum correction to be applied to the setpoint Cooling   |
| P0617      | SWRMaxC           | Value of the WR control signal corresponding to the correction of the set Cool equal to P0616    |
| P0618      | SWRMinC           | Value of the WR control signal corresponding to the correction of the set COOL equal to 0        |
| P0615      | MaxCWRH           | Maximum correction to be applied to the setpoint Heating   |
| P0619      | SWRMaxH           | Value of the WR control signal corresponding to the correction of the set Heating equal to P0615 |
| P0620      | SWRMinH           | Value of the WR control signal corresponding to the correction of the set Heating equal to 0     |

P0616 / P0618: Cooling  
P0615, P0619, P0620: Heating

## 6.15 ECOSHARE function for the automatic management of a group of units

- Max 7 units
- Maximum length of the bus line: 700 m.
- Maximum distance between 2 units: 300 m
- Type of cable: shielded twisted pair cable  $\varnothing$  0,8 mm. use an EIB/KNX cable
- Possible connections: Tree, star, in/out bus, mixed
- It is not possible to use a ring connection
- No end-of-line resistor or terminator required
- There must be suitable arresters to protect the serial lines from the effects of atmospheric discharges
- The data line must be kept separate from the power conductors or powered at different voltage values and away from possible sources of electrical interference

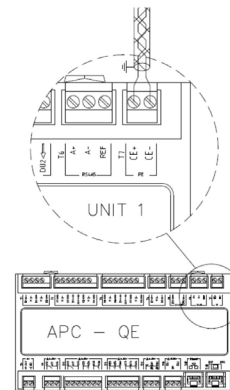
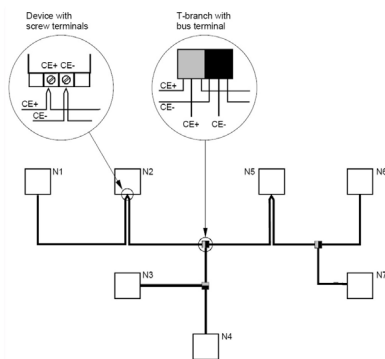

Tree topology (with stub lines)

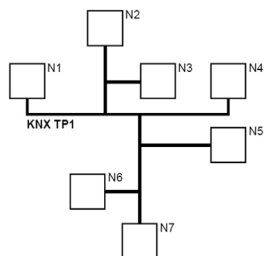

Line topology (with loops)

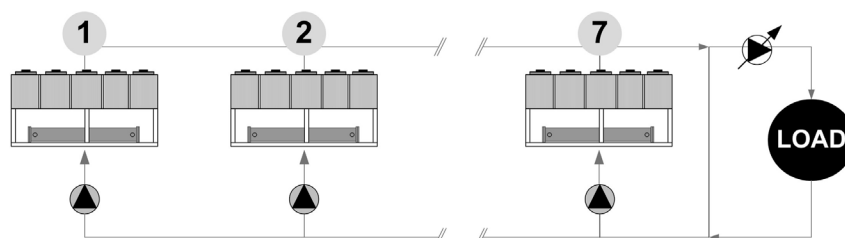
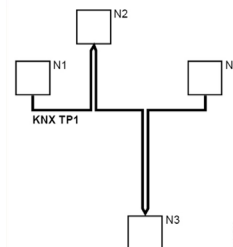

If there are more units connected in a local network set the mode of operation.

**MODE A**

Every unit manages its own compressors according to the setpoint.

Every unit optimizes its refrigeration circuits.

Pumps always active, even with compressor stoped.

P0658 = 0

P0657 > 0 °C

setpoint1 > setpoint2 > setpoint3

or

setpoint1 < setpoint2 < setpoint3

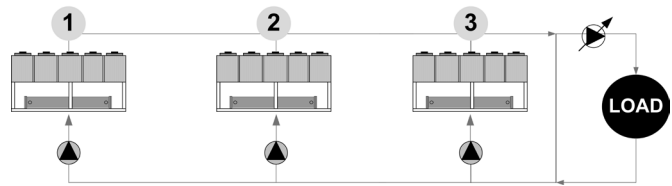

**MODE B**

The master manages the single cooling.

The master optimizes individual refrigerant circuits.

Pumps always active, even with compressor stoped.

P0658 = 1

P0657 = 0 °C

setpoint1 = setpoint2 = setpoint3

plus: optimal H2O temperature control

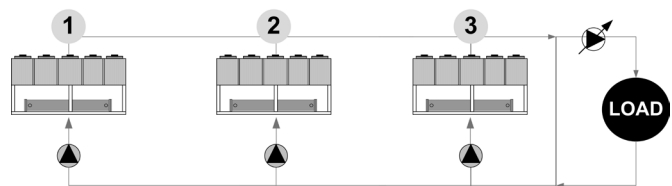

**MODE C**

The master manages the single cooling.

The master optimizes individual refrigerant circuits.

Active pumps only with active compressors.

P0658 = 2

P0657 = 0 °C

setpoint1 = setpoint2 = setpoint3

plus: minimum pumps consumption need balanced system (t1 = t2 = t3)

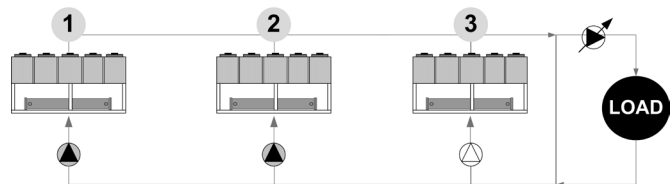

Path: Main Menu / Unit parameters / Master Slave

| Parameters | Short description | Description  |
|------------|-------------------|--|
| P0655      | LNInstalledUnits  | Number of network-connected units including the master   |
| P0656      | LNStandByUnits    | Number of units kept in standby  |
| P0657      | LNOffset          | Temperature Offset the master sum or subtract, depending on the way you set, in order of priority, to the set point of the slave |
| P0658      | TypeRegMS         | Operation mode: 0=mode A; 1=mode B; 2=mode C   |
| P0659      | LNAddress         | ProcessBus address unit  |

## 6.16 Evaporator water flow-rate

Check that the difference between the temperature of exchanger return and supply water corresponds to power according to this formula:  

$$\text{unit cooling power (kW)} \times 860 = \text{Dt (}^{\circ}\text{C)} \times \text{flow rate (L/h)}$$

The cooling power is shown in the table of the GENERAL TECHNICAL DATA included in this manual, referred to specific conditions, or in the tables on COOLING PERFORMANCE in the TECHNICAL BULLETIN referred to various conditions of use.

Check for water side exchanger pressure drops:

determine the water flow rate

measure the difference in pressure between exchanger input and output and compare it with the graph on WATER SIDE EXCHANGER PRESSURE DROPS

The measurement of pressure will be easier if pressure gauges are installed as indicated in the DIAGRAM OF SUGGESTED WATER CONNECTIONS.

## 6.17 Scroll compressor

The Scroll compressors have only one rotation direction.

In the event it is reversed, the compressor is not immediately damaged, but increases its noise and jeopardises pumping.

After a few minutes, the compressor blocks due to intervention of the thermal protection.

In this case, disconnect power supply and invert 2 phases on the machine power supply.

Avoid the compressor working for a long time with contrary rotation: more than 2-3 of these anomalous start-ups can damage it.

To ensure the rotation direction is correct, measure the condensation and suction pressure.

The pressures must significantly differ: upon start-up, the suction pressure decreases whereas the condensation one, increases.

## 6.18 Operating at reduced load

The units are equipped with partialization steps and they can, therefore, operate with reduced loads.

However a constant and long operation with reduced load with frequent stop and start-up of the compressor/s can cause serious damages for the lack of oil return.

The above-described operating conditions must be considered outside the operating limits.

In the event of compressor breakdown, due to operating in the above-mentioned conditions, the guarantee will not be valid and Clivet spa declines any responsibility.

Check periodically the average operating times and the frequency of the compressors starts: approximately the minimum thermal load should be such as to need the operating of a compressor for at least ten minutes.

If the average times are close to this limit, take the proper corrective actions.

## 6.19 Start-up report

Identifying the operating objective conditions is useful to control the unit over time.

With unit at steady state, i.e. in stable and close-to-work conditions, identify the following data:

- total voltages and absorptions with unit at full load
- absorptions of the different electric loads (compressors, fans, pumps etc)
- temperatures and flows of the different fluids (water, air) both in input and in output from the unit
- temperature and pressures on the characteristic points of the refrigerating circuit (compressor discharge, liquid, intake)

The measurements must be kept and made available during maintenance interventions.

## 6.20 2014/68/UE PED directive

DIRECTIVE 2014/68/UE PED gives instructions for installers, users and maintenance technicians as well.

Refer to local regulations; briefly and as an example, see the following:

Compulsory verification of the first installation:

- only for units assembled on the installer's building site (for ex. Condensing circuit + direct expansion unit)

Certification of setting in service:

- for all the units

Periodical verifications:

- to be executed with the frequency indicated by the Manufacturer (see the "maintenance inspections" paragraph)

## 7 Control

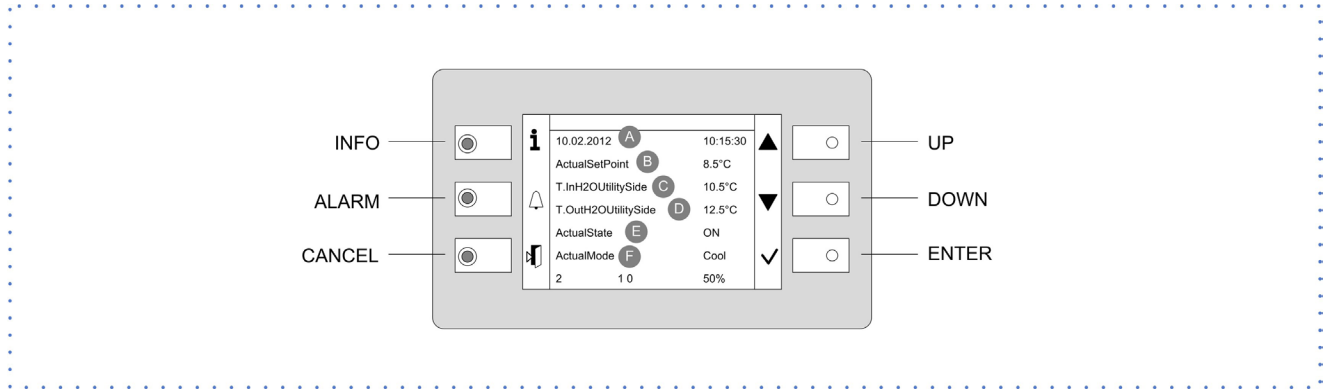

### 7.1 Led

|        |                               |
|--------|-------------------------------|
| INFO   | Not used                      |
| ALARM  | Blink / fixed = alarm present |
| CANCEL | not used currently            |

### 7.2 Display

| Ref. | Variable                   | Description   |
|------|----------------------------|---|
| A    |                            | Date - Time   |
| B    | <b>ActualSetPoint</b>      | Temperature setting   |
| C    | <b>T.InH2OUtilitySide</b>  | Water inlet temperature utility side  |
| D    | <b>T.OutH2OUtilitySide</b> | Water outlet temperature utility side   |
| E    | <b>ActualState</b>         | On / off / eco / pmp On   |
| F    | <b>ActualMode</b>          | Cooling - Cooling+PartRecover - Cooling+FullRecover - Recover - Heating - Heating+Recover |
|      | <b>2</b>                   | Installed compressors   |
|      | <b>1 - 0</b>               | Compressors ON<br>example: circuit 1 = 1 compr. On<br>circuit 2 = 0 compr. On             |
|      | <b>50%</b>                 | Heating capacity  |

### 7.3 Keys

| Symbol | Name   | Description                                 |
|--------|--------|---|
|        | Info   | Main menu                                   |
|        | Alarm  | Alarm display                               |
|        | Cancel | Exit<br>Previous level<br>Keyboard settings |
|        | Up     | Increases value                             |
|        | Down   | Decreases value                             |
|        | Enter  | Confirm<br>Password                         |

## 7.4 Change unit state

| Step | Display   | Action  | Menu/Variable            | Keys |  | Notes |
|------|-----------|---------|--------------------------|------|--|-------|
| 1    |           | Press   |                          |      |  |       |
| 2    | Main menu | Select  | Cmd Local state          |      |  |       |
| 3    |           | Set     | OFF - ECO - ON - Pump On |      |  | *     |
| 4    |           | Confirm |                          |      |  |       |
| 6    |           | Exit    |                          |      |  |       |

\* Local state

ECO: recurrent pump ON-OFF; compressors keep water system at setpoint ECO

Pmp ON: pump ON, compressor OFF

## 7.5 Change the mode

| Step | Display   | Action  | Menu/Variable  | Keys |  | Notes |
|------|-----------|---------|--|------|--|-------|
| 1    |           | Press   |  |      |  |       |
| 2    | Main menu | Select  | Cmd Local mode   |      |  |       |
| 3    |           | Set     | Cooling<br>Cooling+PartRecover<br>Cooling+FullRecover<br>Recover<br>Heating<br>Heating+Recover |      |  |       |
| 4    |           | Confirm |  |      |  |       |
| 5    |           | Exit    |  |      |  |       |

















## 7.6 Modify setpoint

| Step | Display         | Action  | Menu/Variable   | Keys |  | Notes |
|------|-----------------|---------|-----------------|------|--|-------|
| 1    |                 | Press   |                 |      |  |       |
| 2    | Main menu       | Select  | Unit parameters |      |  |       |
| 3    | Unit parameters | Confirm | Set Point       |      |  |       |
| 4    |                 | Select  | Set Point       |      |  |       |
| 5    |                 | Set     | Set Point       |      |  |       |
| 6    |                 | Confirm |                 |      |  |       |
| 7    |                 | Exit    |                 |      |  |       |













| Parameters | Short description  | Description                  |                         |
|------------|--------------------|------------------------------|-------------------------|
| P0583      | SetPointCooling    | Setpoint Cool                |                         |
| P0584      | 2SetPointCooling   | 2° Setpoint Cool             | Enable by remote switch |
| P0855      | SetPointECOCooling | Economic summer SetPoint     |                         |
| P0577      | SetPointHeating    | Setpoint Heat                |                         |
| P0578      | 2SetPointHeating   | 2° Setpoint Heat             |                         |
| P0579      | SetPointECOHeating | Economic winter SetPoint     |                         |
| P0640      | SetPointRecover    | Recovery Set Point           |                         |
| P0580      | ACSSetPoint        | domestic hot water set point |                         |

## 7.7 Scheduler

It is possible to set 6 events (Off, Eco, On, Recirculating) for each week day.







| Step | Display   | Action  | Menu/Variable | Keys  |   | Notes |
|------|-----------|---------|---------------|---|---|-------|
| 1    |           | Press   |               |  |   |       |
| 2    | Main menu | Select  | Scheduler     |  |  |       |
| 3    | Scheduler | Select  | Day           |  |  |       |
| 4    |           | Select  | Time          |  |  |       |
| 5    |           | Set     | Event time    |  |  |       |
| 6    |           | Confirm |               |  |   |       |
| 7    |           | Select  | Value         |  |  |       |
| 8    |           | Set     | On/Eco..      |  |  |       |
| 9    |           | Confirm |               |  |   |       |
| 10   |           | Exit    |               |  |   |       |

### Enable Scheduler

| Step | Display   | Action       | Menu/Variable     | Keys  |   | Notes |
|------|-----------|--------------|-------------------|---|---|-------|
| 1    |           | Press 3 sec. |                   |  |   |       |
| 2    | Password  | Set          | Password          |  |  |       |
| 3    |           | Press        |                   |  |   | *     |
| 4    | Main menu | Select       | Unit Parameters   |  |  |       |
| 5    |           | Select       | Option config     |  |  |       |
| 6    |           | Set          | P0052=1           |  |  |       |
| 7    |           | Press 3 sec. |                   |  |   |       |
|      |           | Select       | Local connections |  |  |       |

\* Unit Parameters menu is displayed

## 7.8 Display the status

| Step | Display   | Action | Menu/Variable           | Keys  |   | Notes |
|------|-----------|--------|-------------------------|---|---|-------|
| 1    |           | Press  |                         |  |   |       |
| 2    | Main menu | Select | Machine State           |  |  |       |
| 3    |           | Select | General, circuit, ecc.. |  |  |       |
| 4    |           | Exit   |                         |  |   |       |

| Nr. | GENERAL STATA              |
|-----|----------------------------|
| 50  | Current Mode               |
| 51  | Current Status             |
| 52  | Current Setpoint User-side |
| 53  | Steps Qty                  |
| 54  | Steps On                   |
| 55  | Current Setpoint Recovery  |
| 56  | Alarms                     |
| 57  | Warning                    |
| 58  | Recovery Request           |
| 59  | User-side Request          |
| 60  | Domestic Hot Water Status  |
| 801 | Recovery Pump 1 Hours      |
| 802 | Recovery Pump 2 Hours      |
| 803 | Recovery Pump 3 Hours      |
| -   | Bitmap Alarms 1            |
| -   | Bitmap Alarms 2            |
| -   | Bitmap Alarms 3            |
| -   | Bitmap Alarms 4            |

| Nr. | USER-SIDE STATA               |
|-----|-------------------------------|
| 80  | User-side Pump 1 Command      |
| 81  | User-side Pump 2 Command      |
| 82  | User-side Pump 3 Command      |
| 83  | User-side Inverter Command    |
| 84  | User-side Inverter Signal     |
| 85  | User-side Inverter Reset      |
| 86  | Pump On for Anti-freeze       |
| 87  | Anti-freeze Heaters User side |
| 88  | User-side Flow Request        |
| 89  | LimitFlow Heating             |
| 90  | LimitFlow Recovery            |
| 91  | LimitFlow Cooling             |
| 92  | User-side Pump 1 Hours        |
| 93  | User-side Pump 2 Hours        |
| 94  | User-side Pump 3 Hours        |

| Nr.  | SOURCE STATA            |
|------|-------------------------|
| 70   | Source Pump 1 Command   |
| 71   | Source Pump 2 Command   |
| 72   | Source Pump 2 Command   |
| 73   | Source Inverter Command |
| 74   | Source Inverter Signal  |
| 75   | Source Inverter Reset   |
| 1601 | Source Pump 1.1 Hours   |
| 1602 | Source Pump 2.1 Hours   |
| 1603 | Source Pump 3.1 Hours   |
| 2601 | Source Pump 1.2 Hours   |
| 2602 | Source Pump 2.2 Hours   |
| 2603 | Source Pump 3.2 Hours   |

| Nr   | CIRCUIT 1 STATA             |
|------|-----------------------------|
| 1001 | Current Schema 1.1          |
| 1002 | SubCooling                  |
| 1003 | Current capacity %          |
| 1004 | Pressure ratio              |
| 1005 | Envelope Zone 1.1           |
| 1006 | Envelope Zone 2.1           |
| 1007 | Envelope Zone 3.1           |
| 1008 | Offset Envelope 1.1         |
| 1009 | Superheat Set PID 3.1       |
| 1100 | Defrost Command 1.1         |
| 1101 | Superheat Set PID 1.1       |
| 1102 | Superheat Set PID 2.1       |
| 1103 | Number Compressors On       |
| 1104 | Compressor 1.1 Starts       |
| 1105 | Compressor 2.1 Starts       |
| 1106 | Compressor 3.1 Starts       |
| 1107 | Compressor 1.1 Hours        |
| 1108 | Compressor 2.1 Hours        |
| 1109 | Compressor 3.1 Hours        |
| -    | EEV PID 1 controller status |
| -    | EEV PID 2 controller status |
| -    | EEV PID 3 controller status |
| -    | Source EEV 1                |
| -    | Source EEV 2                |
| -    | User-side EEV               |
| -    | Bitmap Alarms 1.1           |
| -    | Bitmap Alarms 2.1           |
| -    | Bitmap Alarms 3.1           |
| -    | Bitmap Alarms 4.1           |









| Nr.  | DIGITAL INPUT                  |
|------|--------------------------------|
| 100  | 2nd Setpoint User-side         |
| 101  | Recovery System Load           |
| 102  | User-side System Load          |
| 103  | Domestic Hot Water Request     |
| 104  | Recovery Request               |
| 105  | User-side Request              |
| 106  | F.C. O. YV Cool                |
| 107  | F.C. O. YV Heat                |
| 108  | F.C. C. YV Cool                |
| 109  | F.C. C. YV Heat                |
| 110  | Free-cooling Flow              |
| 111  | Recovery Flow                  |
| 112  | Source Flow                    |
| 113  | User-side Flow                 |
| 114  | Remote Heat/Cool               |
| 115  | Remote On/Off                  |
| 116  | Phase Monitor                  |
| 117  | Free-cooling Pressure          |
| 118  | Recovery Inverter Protection   |
| 119  | Source Inverter Protection     |
| 120  | User-side Inverter Protection  |
| 121  | Free-cooling Pump 1 Protection |
| 122  | Recovery Pump 1 Protection     |
| 123  | Source Pump 1 Protection       |
| 124  | User-side Pump 1 Protection    |
| 125  | Free-cooling Pump 2 Protection |
| 126  | Recovery Pump 2 Protection     |
| 127  | User-side Pump 2 Protection    |
| 128  | Free-cooling Pump 3 Protection |
| 129  | Recovery Pump 3 Protection     |
| 130  | Source Pump 3 Protection       |
| 131  | User-side Pump 3 Protection    |
| 132  | Leak Detector                  |
| 138  | Source Pump 2 protection       |
| 139  | Source System Load             |
| 1180 | High Pressure 1.1              |
| 1181 | Compressor 1.1 Protection      |
| 1182 | Compressor 2.1 Protection      |
| 1184 | Source Fan 1.1 Protection      |
| 2180 | High Pressure 1.2              |
| 2181 | Compressor 1.2 Protection      |
| 2183 | Compressor 2.2 Protection      |
| 2184 | Source Fan 1.2 Protection      |

| Nr.  | ANALOGIC INPUT                         |
|------|--|
| 201  | Demand Limit                           |
| 202  | User-side Differential Pressure switch |
| 203  | Free-cooling Water Temperature         |
| 204  | External Air Temperature               |
| 205  | Recovery In Temperature                |
| 206  | Recovery Out Temperature               |
| 207  | Cabinet Temperature                    |
| 208  | Water Reset                            |
| 830  | User-side In Temperature               |
| 831  | User-side Out Temperature              |
| 885  | Source In Temperature                  |
| 886  | Source Out Temperature                 |
| 1201 | Suction Pressure 1.1                   |
| 1202 | Suction Pressure 2.1                   |
| 1203 | Discharge Pressure 1.1                 |
| 1204 | Suction Temperature 1.1                |
| 1205 | Suction Temp 2.1                       |
| 1206 | Suction Temperature 3.1                |
| 1207 | Source In Temperature 1.1              |
| 1208 | Recovery Liquid Temperature 1.1        |
| 1209 | Source Out Temperature 1.1             |
| 1210 | Discharge Temperature 1.1              |
| 1211 | Discharge Temperature 2.1              |
| 2201 | Suction Pressure 1.2                   |
| 2202 | Suction Pressure 2.2                   |
| 2203 | Discharge Pressure 1.2                 |
| 2204 | Suction Temperature 1.2                |
| 2205 | Suction Temperature 2.2                |
| 2206 | Suction Temperature 3.2                |
| 2207 | Source In Temperature 1.2              |
| 2208 | Recovery Liquid Temperature 1.2        |
| 2209 | Source Out Temperature 1.2             |
| 2210 | Discharge Temperature 1.2              |
| 2211 | Discharge Temperature 2.2              |

| Nr.  | OUTPUT ANALOGICI              |
|------|-------------------------------|
| 301  | User-side YV Bypass           |
| 302  | Grouped Alarms                |
| 303  | Free-cooling Pump 1           |
| 304  | Recovery Pump 1               |
| 305  | Free-cooling Pump 2           |
| 306  | Recovery Pump 2               |
| 307  | Free-cooling Pump 3           |
| 308  | Recovery Pump 3               |
| 309  | Anti-freeze Heaters           |
| 310  | Free-cooling Heaters          |
| 311  | Cabinet Heating               |
| 312  | Cabinet Fan                   |
| 313  | Domestic Hot Water Valve      |
| 314  | Free-cooling Valve Open       |
| 315  | Free-cooling Valve Close      |
| 318  | YV 1 Cooling                  |
| 319  | YV 2 Heating                  |
| 320  | YV 3 Cooling                  |
| 321  | YV 4 Heating                  |
| 1301 | Aries / Defrost Injection 1.1 |
| 1302 | Source Pump 1.1 Command       |
| 1303 | Compressor 1.1 Command        |
| 1304 | Compressor 2.1 Command        |
| 1305 | Liquid Injection 1.1          |
| 1306 | Liquid Injection 2.1          |
| 1307 | RecValve Battery 1.1          |
| 1308 | RecValve Chiller 1.1          |
| 1309 | RecValve Recovery 1.1         |
| 1310 | Reversing Cycle Valve 1.1     |
| 2301 | Aries / Defrost Injection 1.2 |
| 2302 | Source Pump 2.1 Command       |
| 2303 | Compressor 1.2 Command        |
| 2304 | Compressor 2.2 Command        |
| 2305 | Liquid Injection 1.2          |
| 2306 | Liquid Injection 2.2          |
| 2307 | RecValve Battery 1.2          |
| 2308 | RecValve Chiller 1.2          |
| 2309 | RecValve Recovery 1.2         |
| 2310 | Reversing Cycle Valve 1.2     |

| Nr.  | ANALOGIC OUTPUT      |
|------|----------------------|
| 401  | Free-cooling Valve   |
| 402  | Recovery Pump Signal |
| 1401 | Source Fan 1.1       |
| 2401 | Source Fan 1.2       |

## 7.9 Keyboard settings

| Step | Display      | Action       | Menu/Variable     | Keys  |   | Notes |
|------|--------------|--------------|-------------------|---|---|-------|
| 1    |              | Press 3 sec. |                   |  |   |       |
| 2    |              | Press        |                   |  |   |       |
| 3    | HMI Settings | Select       |                   |  |  |       |
| 4    |              | Press        |                   |  |  |       |
| 5    |              | Press        |                   |  |   |       |
| 6    |              | Select       | Local connections |  |  |       |

## 7.10 Alarms



Before resetting an alarm identify and remove its cause.

Repeated resets can cause irreversible damage.















Example:

+ eE0001: Phase monitor: Fault = active alarm

- EE0003: Pum 1 faulty: Ok = resetted alarm

Display of alarm: step 1-3

Reset allarm: step 4-10

| Step | Display             | Action       | Menu/Variable  | Keys  |   | Notes |
|------|---------------------|--------------|----------------|---|---|-------|
| 1    |                     | Press        |                |  |   |       |
| 2    | Alarm list detail   | Press        |                |  |   |       |
| 3    | Alarm list          | Select       | Alarm          |  |  |       |
| 4    | Alarm list detail   | Press 3 sec. |                |  |   |       |
| 5    | Password            | Set          | Enter password |  |  |       |
| 6    | Alarm list detail   | Press        |                |  |   |       |
| 7    | Alarm list          | Select       | Alarm          |  |  |       |
| 8    |                     | Select       | Reset Executed |  |  |       |
| 9    |                     | Press 3 sec. |                |  |   |       |
| 10   | Password management | Select       | Log off        |  |  |       |

## 7.11 General list of alarms

| ELECTRICAL CIRCUIT ALARMS |                               |   |               |
|---------------------------|-------------------------------|---|---------------|
| Num                       | Name                          | Description                                   | Category      |
| eE0001                    | Phase monitor                 | Phase monitor fault                           | Central       |
| EE0003                    | Pump 1 faulty                 | User side pump 1 overload protection          | GP Ut         |
| EE0004                    | Pump 2 faulty                 | User side pump 2 overload protection          | GP Ut         |
| EE0005                    | Pump 3 faulty                 | User side pump 3 overload protection          | GP Ut         |
| eE0008                    | Utility Inverter Protection   | User side inverter overload protection        | GP Ut         |
| ee0010                    | Master Offline                | Master unit offline                           | MS            |
| ee0011                    | Unit 2 in alarm               | 2 <sup>nd</sup> slave unit fault              | MS            |
| ee0012                    | Unit 2 OffLine                | 2 <sup>nd</sup> slave unit offline            | MS            |
| ee0013                    | Unit 3 in alarm               | 3 <sup>rd</sup> slave unit fault              | MS            |
| ee0014                    | Unit 3 OffLine                | 3 <sup>rd</sup> slave unit offline            | MS            |
| ee0015                    | Unit 4 in alarm               | 4 <sup>th</sup> slave unit fault              | MS            |
| ee0016                    | Unit 4 OffLine                | 4 <sup>th</sup> slave unit offline            | MS            |
| ee0017                    | Unit 5 in alarm               | 5 <sup>th</sup> slave unit fault              | MS            |
| ee0018                    | Unit 5 OffLine                | 5 <sup>th</sup> slave unit offline            | MS            |
| ee0019                    | Unit 6 in alarm               | 6 <sup>th</sup> slave unit fault              | MS            |
| ee0020                    | Unit 6 OffLine                | 6 <sup>th</sup> slave unit offline            | MS            |
| ee0021                    | Unit 7 in alarm               | 7 <sup>th</sup> slave unit fault              | MS            |
| ee0022                    | Unit 7 OffLine                | 7 <sup>th</sup> slave unit offline            | MS            |
| ee0027                    | Utility Water In temp Error   | User side in water temperature probe fault    | Central       |
| ee0028                    | Utility Water Out temp Error  | User side out water temperature probe fault   | Central       |
| ee0029                    | Temp Ext Sensor Error         | External air temperature probe fault          | HW            |
| ee0030                    | DemandLimit                   | Demand limit fault                            | HW            |
| ee0031                    | WaterReset                    | Water reset fault                             | HW            |
| ee0032                    | External Humidity probe Error | Relative humidity probe fault                 | HW            |
| ee0033                    | T.Quadro Ele                  | Electrical panel temperature probe fault      | HW            |
| ee0035                    | YV Cool Open                  | YV Cool opening fault                         | 4P            |
| ee0036                    | YV Heat Open                  | YV Heat opening fault                         | 4P            |
| ee0037                    | YV Cool Close                 | YV Cool closing fault                         | 4P            |
| ee0038                    | YV Heat Close                 | YV Heat closing fault                         | 4P            |
| ee0040                    | FCI Water Temp.               | Freecooling water temperature probe fault     | HW FCI        |
| EE0044                    | Pump 1 Allarm                 | Freecooling pump 1 overload protection        | FCI Circuit 1 |
| EE0045                    | Pump 2 Allarm                 | Freecooling pump 2 overload protection        | FCI Circuit 1 |
| EE0046                    | Pump 3 Allarm                 | Freecooling pump 3 overload protection        | FCI Circuit 1 |
| ee0047                    | Pump Change for Utility Flow  | Switching pump on user side for flow alarm    | GP User side  |
| ee0050                    | P.DifferenzialeUtil           | User side differential pressure sensore fault | HW            |
| EE0054                    | Recovery Pump 1 protection    | Recovery side pump 1 overload protection      | Recovery      |
| EE0055                    | Recovery Pump 2 protection    | Recovery side pump 2 overload protection      | Recovery      |
| EE0056                    | Recovery Pump 3 protection    | Recovery side pump 3 overload protection      | Recovery      |
| eE0057                    | Recovery Inverter Protection  | Recovery side inverter overload protection    | Recovery      |
| ee0100                    | TimeOutModPOL98U              | 1 <sup>st</sup> POL98U module disconnected    | HW TimeOut    |
| ee0101                    | TimeOutModPOL98U_2            | 2 <sup>nd</sup> POL98U module disconnected    | HW TimeOut    |
| ee0102                    | TimeOutModPOL96U              | POL96U module disconnected                    | HW TimeOut    |
| ee0103                    | TimeOutModPOL945              | POL945 module disconnected                    | HW TimeOut    |

| ELECTRICAL CIRCUIT ALARMS |                                 |  |              |
|---------------------------|---------------------------------|--|--------------|
| Num                       | Name                            | Description                                    | Category     |
| ee0104                    | TimeOutModPOL965                | POL965 module disconnected                     | HW TimeOut   |
| ee0105                    | TimeOutModPOL94U                | 1 <sup>st</sup> POL94U module disconnected     | HW TimeOut   |
| ee0106                    | TimeOutModPOL94U_2              | 2 <sup>nd</sup> POL94U module disconnected     | HW TimeOut   |
| ee0107                    | TimeOutModPOL985                | POL985 module disconnected                     | HW TimeOut   |
| ee1001                    | T.Suction Gas                   | Gas temperature probe 3 fault                  | HW Circuit 1 |
| ee1002                    | T.Suction Gas                   | Gas temperature probe 5 fault                  | HW Circuit 1 |
| ee1003                    | P.Suction Heat                  | Pressure sensor fault, low pressure heating    | HW Circuit 1 |
| ee1004                    | EEV1 blocked                    | EEV 1 blocked                                  | Circuit 1    |
| ee1005                    | EEV1 blocked                    | EEV2 blocked                                   | Circuit 1    |
| EE1006                    | Comp 1 protections              | Compressor 1 overload protection               | Circuit 1    |
| EE1007                    | Comp 2 protections              | Compressor 2 overload protection               | Circuit 1    |
| EE1008                    | Comp 3 protections              | Compressor 3 overload protection               | Circuit 1    |
| EE1009                    | Source Inverter Protection      | Source side inverter overload protection       | Source 1     |
| ee1010                    | Pump Change for Source Flow     | Switching pump on source side for flow alarm   | Source 1     |
| EE1013                    | Source Pump 1 protection        | Source side pump 1 overload protection         | Source 1     |
| EE1014                    | Source Pump 2 protection        | Source side pump 2 overload protection         | Source 1     |
| EE1015                    | Source Pump 3 protection        | Source side pump 3 overload protection         | Source 1     |
| EE1018                    | Source side protection          | Source side ventilation overload protection    | Circuit 1    |
| ee1022                    | T.Discharge C1.1                | Compressor 1 discharge temperature probe fault | HW Circuit 1 |
| ee1023                    | T.Discharge C2.1                | Compressor 2 discharge temperature probe fault | HW Circuit 1 |
| ee1024                    | T.Discharge C3.1                | Compressor 3 discharge temperature probe fault | HW Circuit 1 |
| ee1025                    | T.Source 1                      | Source 1 temperature probe fault               | HW Circuit 1 |
| ee1026                    | T.Source 2                      | Source 2 temperature probe fault               | HW Circuit 1 |
| ee1027                    | T.Suction Gas                   | Suction temperature probe fault                | HW Circuit 1 |
| ee1028                    | P.Discharge                     | High pressure probe fault                      | HW Circuit 1 |
| ee1029                    | P.Suction                       | Low pressure probe fault                       | HW Circuit 1 |
| ee1030                    | T.GasRecovery                   | Recovery exchanger gas temperature probe fault | HW Circuit 1 |
| ee1031                    | P.GasRecovery                   | Recovery exchanger gas pressure probe fault    | HW Circuit 1 |
| ee1032                    | T.Ing Recovery                  | Recovery in temperature probe fault            | HW Circuit 1 |
| ee1033                    | T.Out Recovery                  | Recovery out temperature probe fault           | HW Circuit 1 |
| ee1037                    | Alarm Inverter 1                | Inverter 1 in alarm                            | Inverter APY |
| ee1038                    | Alarm missing comunication inv1 | Inverter 1 Modbus communication error          | Inverter APY |
| ee1039                    | Timeout comunication inv1       | Inverter 1 communication timeout               | Inverter APY |
| ee1040                    | Alarm Inverter 2                | Inverter 2 in alarm                            | Inverter APY |
| ee1041                    | Alarm missing comunication inv2 | Inverter 2 Modbus communication error          | Inverter APY |
| ee1042                    | Timeout comunication inv2       | Inverter 2 communication timeout               | Inverter APY |
| ee1043                    | Alarm Inverter 3                | Inverter 3 in alarm                            | Inverter APY |
| ee1044                    | Alarm missing comunication inv3 | Inverter 3 Modbus communication error          | Inverter APY |
| ee1045                    | Timeout comunication inv3       | Inverter 3 communication timeout               | Inverter APY |
| EE1047                    | Alarm Envelop Comp1             | Compressor 1 envelope alarm                    | Circuit 1    |
| EE1048                    | Alarm Envelop Comp2             | Compressor 2 envelope alarm                    | Circuit 1    |
| EE1049                    | Alarm Envelop Comp3             | Compressor 3 envelope alarm                    | Circuit 1    |
| ee1055                    | Alarm Inverter 1                | Inverter 1 in alarm                            | Inverter DFS |
| ee1056                    | Alarm missing comunication inv1 | Inverter 1 Modbus communication error          | Inverter DFS |
| ee1057                    | Timeout comunication inv1       | Inverter 1 communication timeout               | Inverter DFS |

| ELECTRICAL CIRCUIT ALARMS |                                  |  |              |
|---------------------------|----------------------------------|--|--------------|
| Num                       | Name                             | Description                                    | Category     |
| ee1058                    | Alarm Inverter 2                 | Inverter 2 in alarm                            | Inverter DFS |
| ee1059                    | Alarm missing communication inv2 | Inverter 2 Modbus communication error          | Inverter DFS |
| ee1060                    | Timeout communication inv2       | Inverter 2 communication timeout               | Inverter DFS |
| ee1061                    | Alarm Inverter 3                 | Inverter 3 in alarm                            | Inverter DFS |
| ee1062                    | Alarm missing communication inv3 | Inverter 3 Modbus communication error          | Inverter DFS |
| ee1063                    | Timeout communication inv3       | Inverter 3 communication timeout               | Inverter DFS |
| ee1070                    | User side ECV 1.1                | User side ECV connection problem               | HW Circuit 1 |
| ee1071                    | Source ECV 1.1                   | Source side ECV 1 connection problem           | HW Circuit 1 |
| ee1072                    | Source ECV 2.1                   | Source side ECV 2 connection problem           | HW Circuit 1 |
| ee2001                    | T.Suction Gas                    | Gas temperature probe 4 fault                  | HW Circuit 2 |
| ee2002                    | T.Suction Gas                    | Gas temperature probe 6 fault                  | HW Circuit 2 |
| ee2003                    | P.Suction Heat                   | Pressure sensor fault, low pressure heating    | HW Circuit 2 |
| ee2004                    | EEV1 blocked                     | EEV1 blocked                                   | Circuit 2    |
| ee2005                    | EEV1 blocked                     | EEV2 blocked                                   | Circuit 2    |
| EE2006                    | Comp 1 protections               | Compressor 1 overload protection               | Circuit 2    |
| EE2007                    | Comp 2 protections               | Compressor 2 overload protection               | Circuit 2    |
| EE2008                    | Comp 3 protections               | Compressor 3 overload protection               | Circuit 2    |
| EE2009                    | Source Inverter Protection       | Source side inverter overload protection       | Source 2     |
| ee2010                    | Pump Change for Source Flow      | Switching pump on source side for flow alarm   | Source 2     |
| EE2013                    | Source Pump 1 protection         | Source side pump 1 overload protection         | Source 2     |
| EE2014                    | Source Pump 2 protection         | Source side pump 2 overload protection         | Source 2     |
| EE2015                    | Source Pump 3 protection         | Source side pump 3 overload protection         | Source 2     |
| EE2018                    | Source side protection           | Source side ventilation overload protection    | Circuit 2    |
| ee2022                    | T.Discharge C1.1                 | Compressor 1 discharge temperature probe fault | HW Circuit 2 |
| ee2023                    | T.Discharge C2.1                 | Compressor 2 discharge temperature probe fault | HW Circuit 2 |
| ee2024                    | T.Discharge C3.1                 | Compressor 3 discharge temperature probe fault | HW Circuit 2 |
| ee2025                    | T.Source 1                       | Source 1 temperature probe fault               | HW Circuit 2 |
| ee2026                    | T.Source 2                       | Source 2 temperature probe fault               | HW Circuit 2 |
| ee2027                    | T.Suction Gas                    | Suction gas temperature probe fault            | HW Circuit 2 |
| ee2028                    | P.Discharge                      | High pressure probe fault                      | HW Circuit 2 |
| ee2029                    | P.Suction                        | Low pressure probe fault                       | HW Circuit 2 |
| ee2030                    | T.GasRecovery                    | Recovery exchanger gas temperature probe fault | HW Circuit 2 |
| ee2031                    | P.GasRecovery                    | Recovery exchanger gas pressure probe fault    | HW Circuit 2 |
| ee2032                    | T.Ing Recovery                   | Recovery in temperature probe fault            | HW Circuit 2 |
| ee2033                    | T.Out Recovery                   | Recovery out temperature probe fault           | HW Circuit 2 |
| ee2037                    | Alarm Inverter 1                 | Inverter 1 in alarm                            | Inverter APY |
| ee2038                    | Alarm missing communication inv1 | Inverter 1 Modbus communication error          | Inverter APY |
| ee2039                    | Timeout communication inv1       | Inverter 1 communication timeout               | Inverter APY |
| ee2040                    | Alarm Inverter 2                 | Inverter 2 in alarm                            | Inverter APY |
| ee2041                    | Alarm missing communication inv2 | Inverter 2 Modbus communication error          | Inverter APY |
| ee2042                    | Timeout communication inv2       | Inverter 2 communication timeout               | Inverter APY |

| <b>ELECTRICAL CIRCUIT ALARMS</b> |                                 |                                       |                 |
|----------------------------------|---------------------------------|---------------------------------------|-----------------|
| <b>Num</b>                       | <b>Name</b>                     | <b>Description</b>                    | <b>Category</b> |
| ee2043                           | Alarm Inverter 3                | Inverter 3 in alarm                   | Inverter APY    |
| ee2044                           | Alarm missing comunication inv3 | Inverter 3 Modbus communication error | Inverter APY    |
| ee2045                           | Timeout comunication inv3       | Inverter 3 communication timeout      | Inverter APY    |
| EE2047                           | Alarm Envelop Comp1             | Compressor 1 envelope alarm           | Circuit 2       |
| EE2048                           | Alarm Envelop Comp2             | Compressor 2 envelope alarm           | Circuit 2       |
| EE2049                           | Alarm Envelop Comp3             | Compressor 3 envelope alarm           | Circuit 2       |
| ee2055                           | Alarm Inverter 1                | Inverter 1 in alarm                   | Inverter DFS    |
| ee2056                           | Alarm missing comunication inv1 | Inverter 1 Modbus communication error | Inverter DFS    |
| ee2057                           | Timeout comunication inv1       | Inverter 1 communication timeout      | Inverter DFS    |
| ee2058                           | Alarm Inverter 2                | Inverter 2 in alarm                   | Inverter DFS    |
| ee2059                           | Alarm missing comunication inv2 | Inverter 2 Modbus communication error | Inverter DFS    |
| ee2060                           | Timeout comunication inv2       | Inverter 2 communication timeout      | Inverter DFS    |
| ee2061                           | Alarm Inverter 3                | Inverter 3 in alarm                   | Inverter DFS    |
| ee2062                           | Alarm missing comunication inv3 | Inverter 3 Modbus communication error | Inverter DFS    |
| ee2063                           | Timeout comunication inv3       | Inverter 3 communication timeout      | Inverter DFS    |
| ee2070                           | User side ECV 1.1               | User side ECV connection problem      | HW Circuit 2    |
| ee2071                           | Source ECV 1.1                  | Source side ECV 1 connection problem  | HW Circuit 2    |
| ee2072                           | Source ECV 2.1                  | Source side ECV 2 connection problem  | HW Circuit 2    |

| <b>REFRIGERANT CIRCUIT ALARMS</b> |                              |   |                 |
|-----------------------------------|------------------------------|---|-----------------|
| <b>Num</b>                        | <b>Name</b>                  | <b>Description</b>                                      | <b>Category</b> |
| ff1005                            | Min overheating EEV1         | Value of refrigerant superheat too low EEV1 (user side) | Circuit 1       |
| ff1006                            | Min overheating EEV2         | Value of refrigerant superheat too low EEV1 (source)    | Circuit 1       |
| ff1009                            | Low Pressure Alarm (DI)      | Low Pressure Alarm (DI)                                 | Circuit 1       |
| ff1010                            | Warning LP Cool              | Low Pressure Pre Alarm in Cooling Mode                  | Circuit 1       |
| ff1011                            | Warning LP Heat              | Low Pressure Pre Alarm in Heating Mode                  | Circuit 1       |
| ff1012                            | Low pressure Alarm Heat (AI) | Low Pressure in Heating Mode (AI)                       | Circuit 1       |
| ff1013                            | High Pressure (DI)           | High Pressure Alarm (DI)                                | Circuit 1       |
| ff1014                            | Warning High Pressure        | High Pressure Pre Alarm                                 | Circuit 1       |
| ff1015                            | High Pressure Alarm (AI)     | High Pressure Alarm (AI)                                | Circuit 1       |
| ff1016                            | Max RC Warning               | Maximum Pressure Ratio Pre Alarm                        | Circuit 1       |
| ff1017                            | Min RC Alarm                 | Minimum Pressure Ratio Pre Alarm                        | Circuit 1       |
| ff1018                            | Low Pressure Alarm Cool(AI)  | Low Pressure Alarm in Cooling Mode                      | Circuit 1       |
| FF1019                            | Max RC Alarm                 | Maximum Pressure Ratio                                  | Circuit 1       |
| FF1034                            | Vacuum Circuit               | Vaacum Alarm  | Circuit 1       |
| FF1046                            | LimLp                        | Low pressure limit                                      | Circuit 1       |
| ff1047                            | DFRForced                    | Defrost Forced  | Circuit 1       |
| ff1048                            | DFRWaterTLow                 | Low water temperature for defrost operation             | Circuit 1       |
| ff1049                            | DFRTimeMax                   | Defrost Maximum Time                                    | Circuit 1       |

| REFRIGERANT CIRCUIT ALARMS |                              |  |           |
|----------------------------|------------------------------|--|-----------|
| Num                        | Name                         | Description                              | Category  |
| ff2005                     | Min overheating EEV1         | Min Superheat value (user side)          | Circuit 2 |
| ff2006                     | Min overheating EEV2         | Min Superheat value (source)             | Circuit 2 |
| ff2009                     | Low Pressure Alarm (DI)      | Low pressure Alarm (DI)                  | Circuit 2 |
| ff2010                     | Warning LP Cool              | Low pressure Pre Alarm CoolingMode       | Circuit 2 |
| ff2011                     | Warning LP Heat              | Low pressure Pre Alarm HeatingMode       | Circuit 2 |
| ff2012                     | Low pressure Alarm Heat (AI) | Low pressure Pre Alarm Heating Mode (AI) | Circuit 2 |
| ff2013                     | High Pressure (DI)           | High pressure Alarm (DI)                 | Circuit 2 |
| ff2014                     | Warning High Pressure        | High pressure Pre Alarm                  | Circuit 2 |
| ff2015                     | High Pressure Alarm (AI)     | High pressure Alarm (AI)                 | Circuit 2 |
| ff2016                     | Max RC Warning               | Maximum pressure Ratio Pre Alarm         | Circuit 2 |
| ff2017                     | Min RC Alarm                 | Minimum pressure Ratio Pre Alarm         | Circuit 2 |
| ff2018                     | Low Pressure Alarm Cool(AI)  | Low Pressure Alarm Cooling Mode          | Circuit 2 |
| FF2019                     | Max RC Alarm                 | Maximum Pressure Radio                   | Circuit 2 |
| FF2034                     | Vacuum Circuit               | Vaacum Alarm                             | Circuit 2 |
| FF2046                     | LimLp                        | Low pressure limit                       | Circuit 2 |
| ff2047                     | DFRForced                    | Defrost Forced                           | Circuit 2 |
| ff2048                     | DFRWaterTLow                 | Low water temperature for defrost        | Circuit 2 |
| ff2049                     | DFRTimeMax                   | Defrost Time                             | Circuit 2 |

| HYDRAULIC CIRCUIT ALARMS |  |   |                |
|--------------------------|--|---|----------------|
| Num                      | Name                                     | Description   | Category       |
| iI0002                   | Water pressure                           | User side low water pressure  | GP Ut          |
| iI0006                   | Flow switch utility side                 | User side low flow rate   | GP Ut          |
| II0007                   | Freeze alarm                             | User side Water Frost Protection  | Centrale       |
| ii0008                   | Pumps antifreeze alarm                   | Pump activation Water Frost Protection  | Centrale       |
| II0009                   | Inconsistent deltaT across the exchanger | Water outlet temperature, discordant with the current operation mode, user side | Centrale       |
| II0042                   | Pressure allarm                          | Freecooling low water pressure  | FCI Circuito 1 |
| II0043                   | Freeze alarm                             | Freecooling water frost protection  | FCI Circuito 1 |
| ii0047                   | Flow switch allarm                       | Freecooling water low flow rate   | FCI Circuito 1 |
| iI0052                   | Recovery Low H2O Flow                    | Recovery water low flow rate  | Recupero       |
| iI0053                   | Recovery Low Pressure Plant              | Recovery low water pressure   | Recupero       |
| iI1017                   | Source Low Pressure Plant                | Source low water pressure   | Sorgente 1     |
| iI1020                   | Source Low H2O Flow                      | Source side low water flow  | Sorgente 1     |
| II1021                   | Source H2O Freeze Alarm                  | Source side water frost protection  | Sorgente 1     |
| iI2017                   | Source Low Pressure Plant                | Source low water pressure   | Sorgente 2     |
| iI2020                   | Source Low H2O Flow                      | Source side low water flow  | Sorgente 2     |
| II2021                   | Source H2O Freeze Alarm                  | Source side water frost protection  | Sorgente 2     |

## 8 Maintenance

### 8.1 General description

Maintenance must be done by authorized centres or by qualified personnel.

The maintenance allows to:

- maintain the unit efficiency
- increase the life span of the equipment
- assemble information and data to understand the state of the unit efficiency and avoid possible damages

Before checking, please verify the following:

- the electrical power supply line should be isolated at the beginning
- the unit isolator is open, locked and equipped with the suitable warning
- make sure no tension is present



After turning off the power, wait at least 5 minutes before accessing to the electrical panel or any other electrical component.



Before accessing check with a multimeter that there are no residual stresses.

### 8.2 Inspections frequency

Perform an inspection every 6 months minimum.

The frequency, however, depends on the use.



In the event of frequent use it is recommended to plan inspections at shorter intervals:

- frequent use (continuous or very intermittent use, near the operating limits, etc)
- critical use (service necessary)

| √  | intervention frequency (months)  | 1 | 6 | 12 |
|----|--|---|---|----|
| 1  | presence corrosion   |   |   | X  |
| 2  | panel fixing   |   |   | X  |
| 3  | water filter cleaning  |   | X |    |
| 4  | water: quality, ph, weight of glycol (%)   |   | X |    |
| 5  | check the exchanger efficiency   |   |   | X  |
| 6  | circulating pumps  |   | X |    |
| 7  | check of the fixing and the insulation of the power lead   |   |   | X  |
| 8  | check of the earthing cable  |   |   | X  |
| 9  | electric panel cleaning  |   |   | X  |
| 10 | capacity contactor status  |   |   | X  |
| 11 | termina closing, cable insulation integrity  |   |   | X  |
| 12 | voltage and phase unbalancing (no load and on-load)  |   | X |    |
| 13 | absorptions of the single electrical loads   |   | X |    |
| 14 | test of the compressor crankcase heaters   |   | X |    |
| 15 | Checking for leaks   |   |   | *  |
| 16 | survey of the refrigerant circuit operating parameters   |   | X |    |
| 17 | safety valve   |   |   | *  |
| 18 | protective device test: pressure switches, thermostats, flow switches etc..                                |   | X |    |
| 19 | control system test: setpoint, climatic compensations, capacity stepping, water / air flow-rate variations |   | X |    |
| 20 | control device test: alarm signalling, thermometers, probes, pressure gauges etc..                         |   | X |    |

\* Refer to the local regulations; and ensure correct adherence. Companies and technicians that effect interventions of installation, maintenance/repairs, leak control and recovery must be CERTIFIED as expected by the local regulations. The leak control must be effected with annual renewal.

### 8.3 Unit booklet

It's advisable to create a unit booklet to take notes of the unit interventions.

In this way it will be easier to adequately note the various interventions and aid any troubleshooting.

Report on the booklet:

- date
- intervention description
- carried out measures etc.

### 8.4 Standby mode

If a long period of inactivity is foreseen:

- turn off the power
- avoid the risk of frost (empty the system or add glycol)

Turn off the power to avoid electrical risks or damages by lightning strikes.



With lower temperatures keep heaters turned on in of the electrical panel (option).

It's recommended that the re-start after the stopping period is performed by a qualified technician, especially after seasonal stops or seasonal switching.

When restarting, refer to what is indicated in the "start-up" section.

Schedule technical assistance in advance to avoid hitches and to guarantee that the system can be used when required.

### 8.5 Water side exchanger

It is very important for the exchanger to be able to provide the maximum thermal exchange, therefore it is essential for the inner surfaces to be clean of dirt and incrustations.

Periodically check the difference between the temperature of the supply water and the condensation temperature: if the difference is greater than 8°C–10°C it is advisable to clean the exchanger.

The clearing must be effected:

- with circulation opposite to the usual one
- with a speed at least 1,5 times higher than the nominal one
- with an appropriate product moderately acid (95% water + 5% phosphoric acid)
- after the cleaning rinse with water to inhibit the action of any residual product

### 8.6 Circulating pumps

Check:

- no leaks
- bearing status (anomalies are highlighted by abnormal noise and vibration)
- the terminal protection covers are closed and the cable holders are properly positioned

### 8.7 Insulations

Check the condition of the insulations: if necessary apply glue and and renew the seals.

### 8.8 Water filter

Check that no impurities prevent the correct passage of water.

### 8.9 Flow Switch

- controls the operations
- remove incrustations from the palette

### 8.10 Compressor supply line shut-off valve

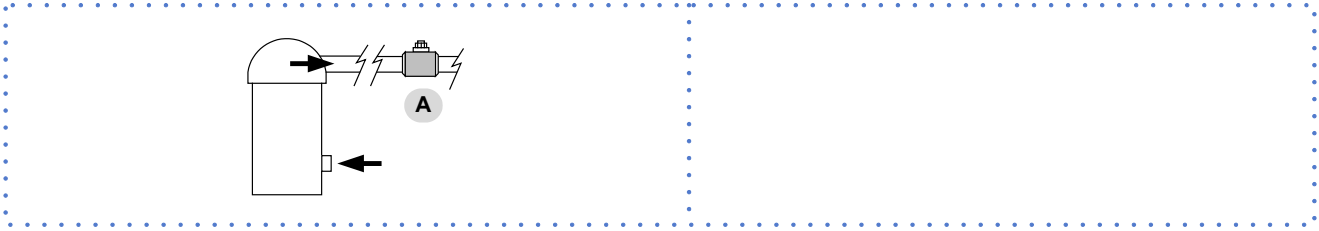

A. Supply line shut-off valve



Do not remove the seal  
Remove only if authorized by the manufacturer.  
Please contact the maker for informations.

### 8.11 crankcase heater

Check:

- closure
- Operation

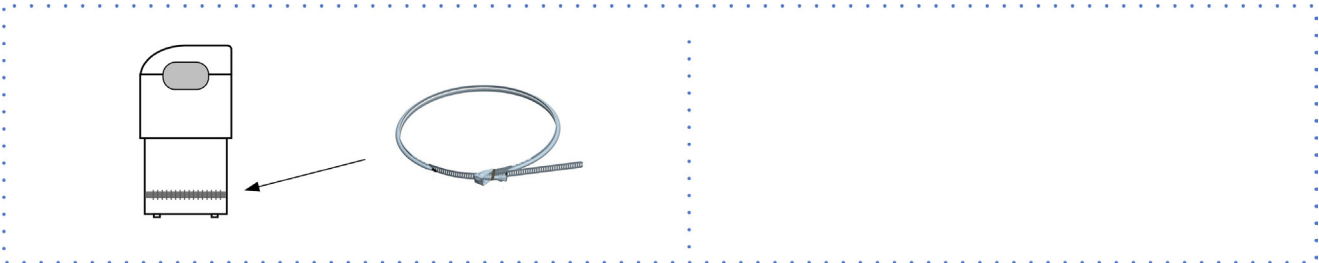

### 8.12 Copeland scroll compressor

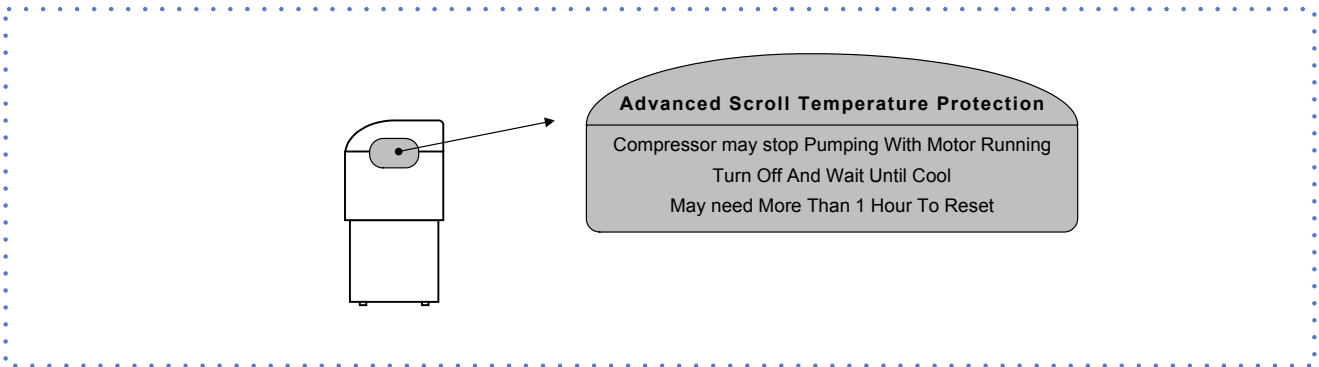

## 8.13 System discharge

1. evacuate the system
2. evacuate the exchanger, use all the present taps
3. use compressed air to blow the exchanger
4. dry completely the exchanger by an hot air jet; for greater safety fill the exchanger with glycoled solution
5. protect the exchanger from the air
6. remove the drain plugs to the pumps



Any anti-freeze liquid contained in the system should not be discharged freely as it is a pollutant.

It must be collected and reused.

Before starting a washing the plant.

Example

- emptying pump

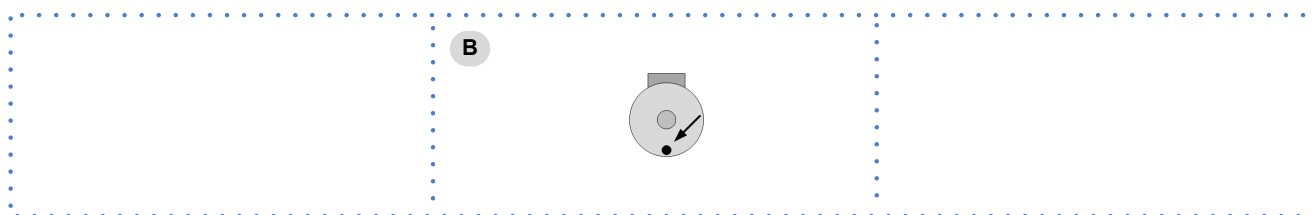

It's recommended that the re-start after the stopping period is performed by a qualified technician, especially after seasonal stops or seasonal switching.

When restarting, refer to what is indicated in the "start-up" section.

Schedule technical assistance in advance to avoid hitches and to guarantee that the system can be used when required.

## 9 Accessories

### 9.1 User side hydronic unit configurations

- 1 standard unit
- 2 VARYFLOW + 2 inverter pumps

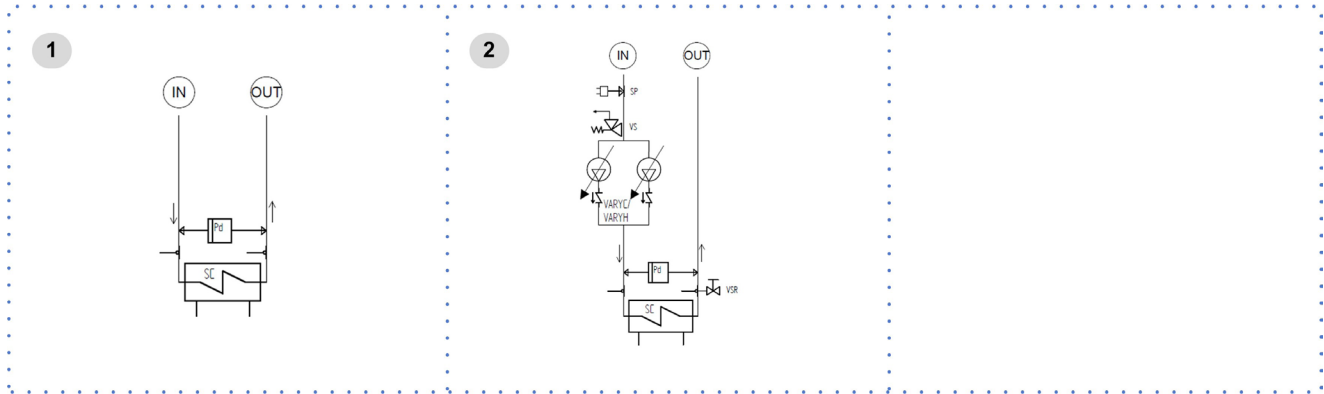

SP pressure switch of the charged system  
 PD Differential pressure switch  
 SC plate exchanger

VSU safety valve  
 VSR Drain valve

### 9.2 Recovery side hydronic unit configurations

- 1 standard unit
- 2 VARYFLOW + 2 inverter pumps

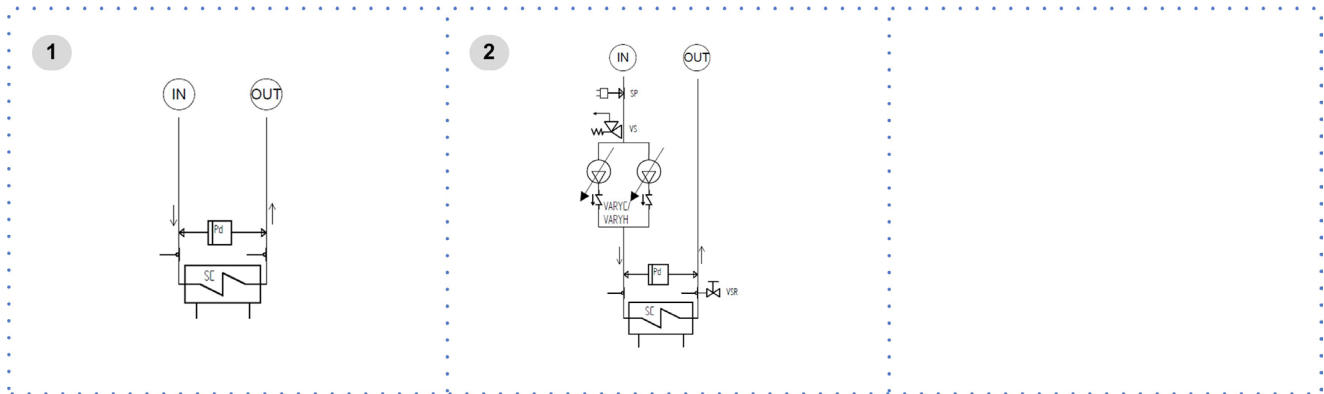

SP pressure switch of the charged system  
 PD Differential pressure switch  
 SC plate exchanger

VSU safety valve  
 VSR Drain valve

### 9.3 Source side hydhydraulic assembly configurations

- |   |  |   |   |
|---|--|---|---|
| 1 | standard unit                                    | 4 | Source side hydronic assembly with 2 ON/OFF pumps |
| 2 | VARYFLOW + (heating side 2 inverter pumps)       | 5 | Source side 3-way modulating valve                |
| 3 | Source side hydronic assembly with 1 ON/OFF pump | 6 | Source side 2-way modulating valve                |

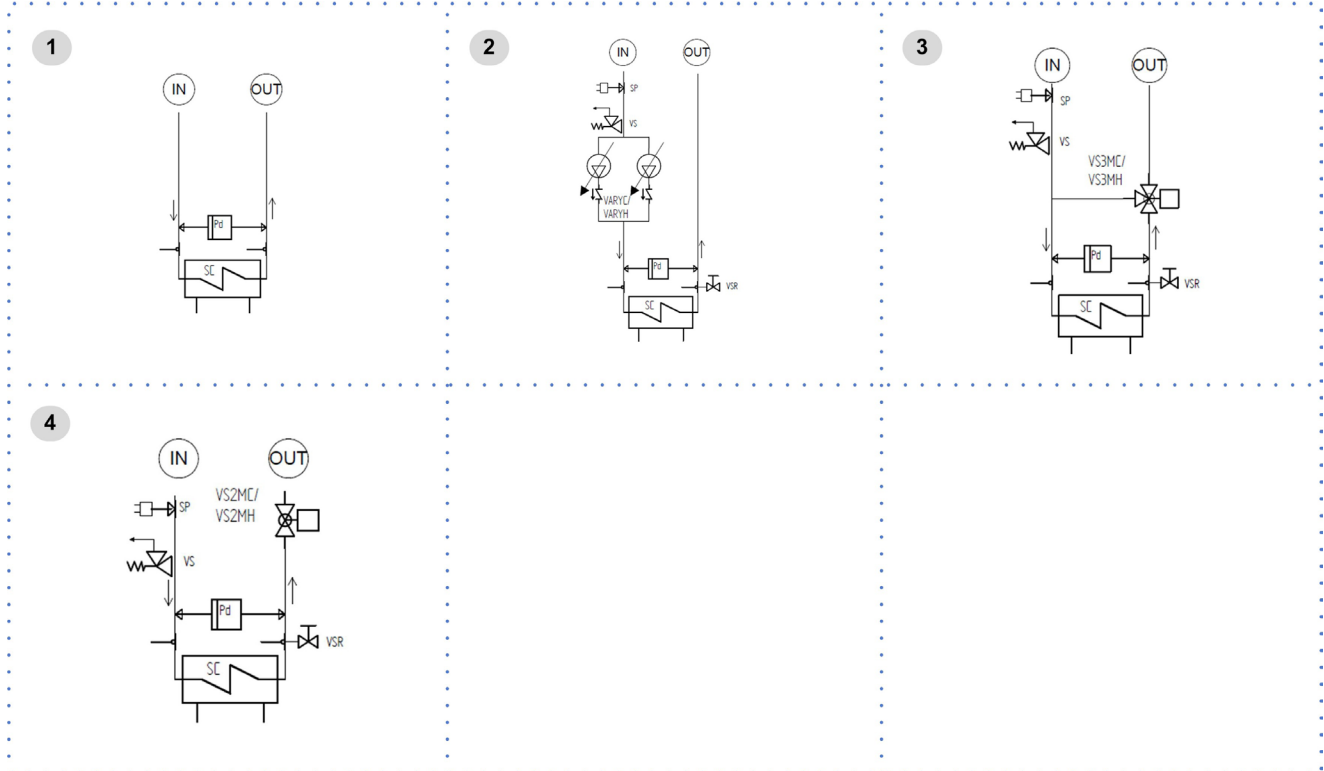

SP pressure switch of the charged system  
 PD Differential pressure switch  
 SC plate exchanger

VSS safety valve  
 VSR Drain valve

## 9.4 Source side 3-way modulating valve

UNIT : source side

SYSTEM : source side

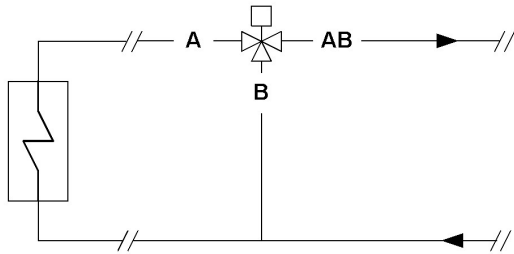

### Parameters settings

| Par. | Description                  | Value |
|------|------------------------------|-------|
| 21   | Enable source signal         | 1     |
| 513  | Flow control: with valve = 1 | 1     |
| 505  | Min source signal (%)        | 50    |
| 506  | Max source signal (%)        | 100   |

### Size 12.2 – 40.2

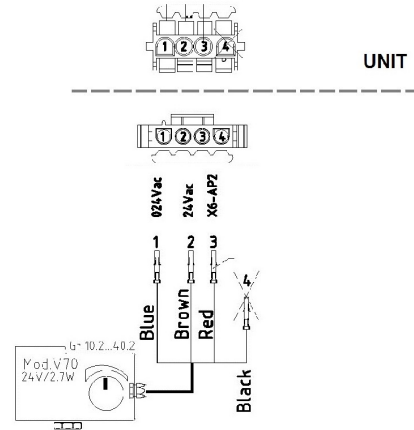
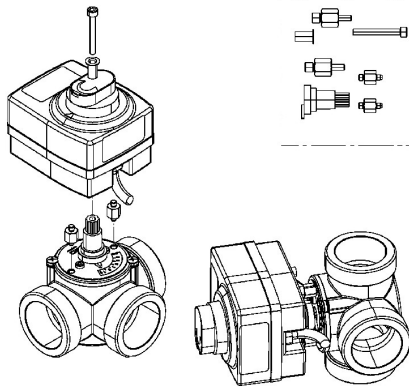

### Size 45.2 – 80.2

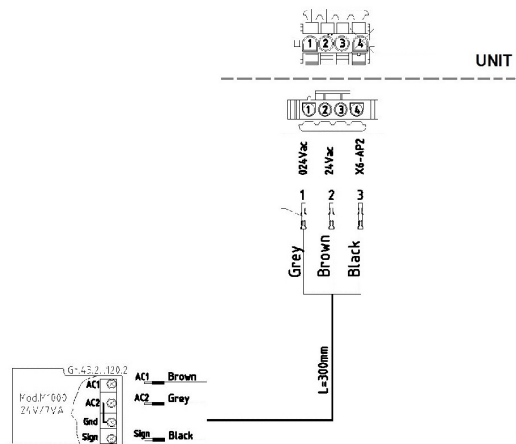
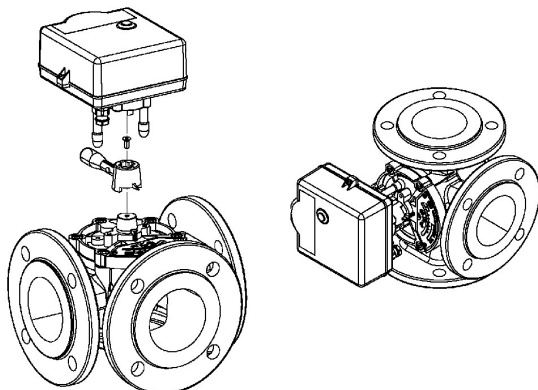

## 9.5 Source side 2-way modulating valve

UNIT : source side

SYSTEM : source side

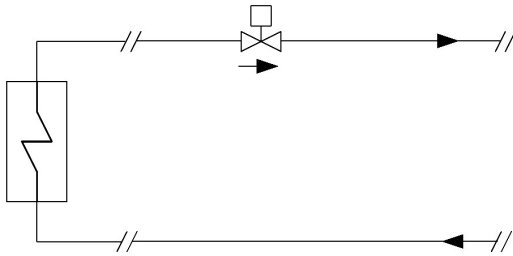

### Parameters settings

| Par. | Description                  | Value |
|------|------------------------------|-------|
| 21   | Enable source signal         | 1     |
| 513  | Flow control: with valve = 1 | 1     |
| 505  | Min source signal (%)        | 50    |
| 506  | Max source signal (%)        | 100   |

### Size 12.2 – 40.2

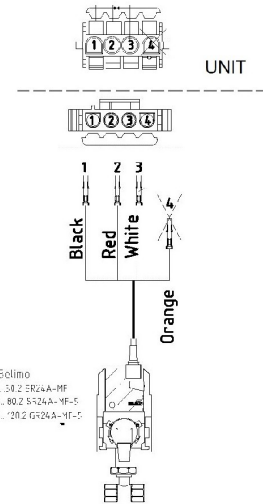
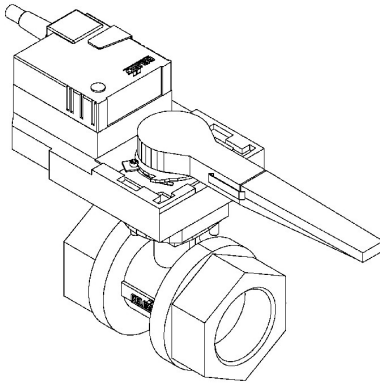

### Size 45.2 – 80.2

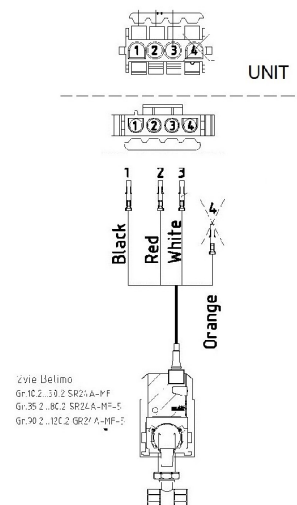
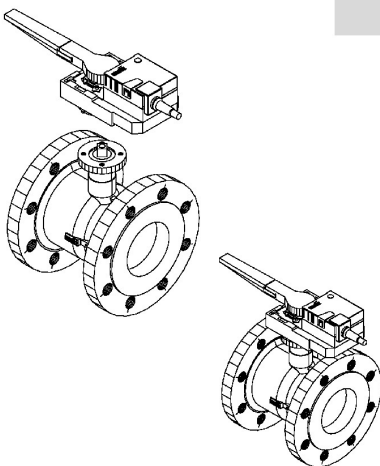

## 9.6 VALVE FOR DOMESTIC HOT WATER

UNIT : recovery side

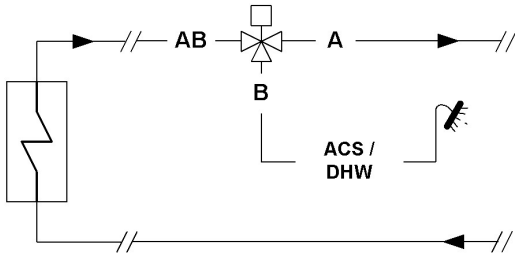

### Parameters settings

| Par. | Description               | Value |
|------|---------------------------|-------|
| 23   | Enable domestic hot water | 1     |
| 580  | Setpoint                  |       |

### Size 12.2 – 40.2

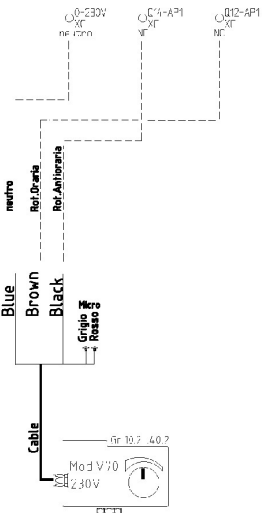
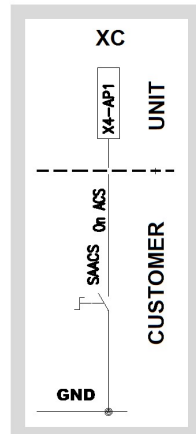
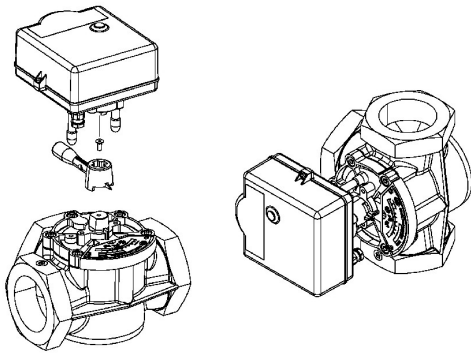

### Size 45.2 – 80.2

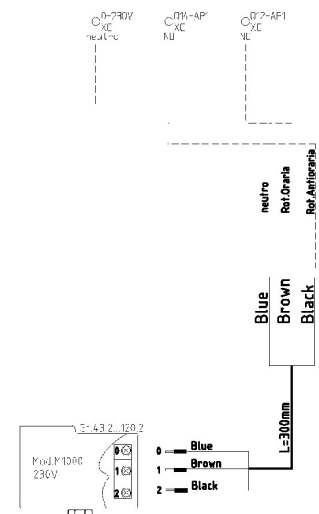
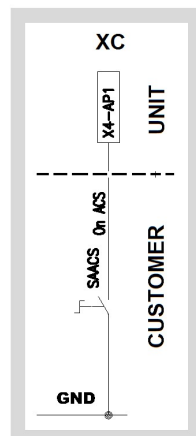
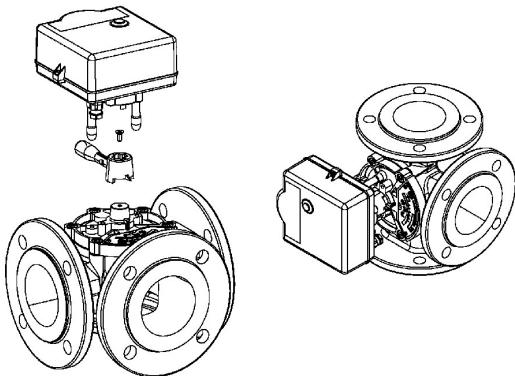

## 9.7 NATURAL COOLING function

Enabling the Natural Cooling functions, the unit is able to independently manage a system for cold production using source water in the event the temperature conditions of the fluid are favorable.

In this case, the source is managed as if it were the first unit available capacity step and can be used to cover the 100% of the cooling load or also, in integration to the compressors, to cover a part of the cold demand by resetting or reducing the compressor power input.

The Natural Cooling installation should include the following additional components (not supplied by Clivet):

1) Natural Cooling water/water exchanger (SCNC in the main scheme): this exchanger shall be suitably dimensioned according to the fluid temperature, user and source side, and according to the pressure drop of the remaining part of the installation and to the unit available static pressure if pumps are not built-in.

2) Two 3-way on/off or equivalent valves (VNCS and VNCU in the main scheme): one on the source circuit and one on the user circuit. Also these have to be suitably dimensioned according to the expected flow rates.

For the correct operation of the Natural Cooling function, the set point control must be set on supply (parameter 436 Tiporeg).

In the installation set up phase it will be necessary to remotely the probe on the source input water upstream of the switching valve source side (VNCS).

The unit can be selected with or without hydronic assemblies user and source side: the system must be able to absorb/manage the flow rate/head variations due to the heater change after the Natural Cooling exchanger insertion and exclusion.

The unit control provides an on/off signal to enable the Natural Cooling by switching the valves.

The Natural Cooling is enabled if the two following conditions are satisfied:

1) the entering water temperature, source side, must be lower than the cooling set point plus a delta defined by parameter 365 DeltaNC (the value can be positive or negative)  $[T_{ws\_in} < (Set\_cooling + \Delta NC)]$

2) the entering water temperature, user side, must be higher than the entering water temperature, source side, plus a delta defined by parameter 366 IsteresiStopNC (the value can be only positive)  $[T_{ws\_in} < (T_{wu\_in} + IsteresiStopNC)]$

If one of these two conditions is not satisfied the Natural Cooling is disabled.

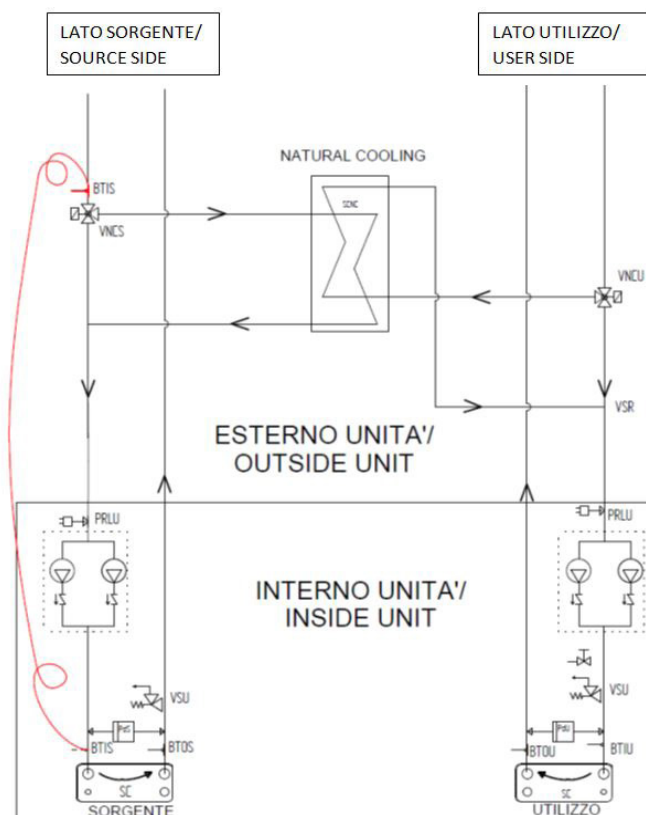

PDU Differential pressure switch, user side  
 PDS Differential pressure switch, source side  
 PRLU Installation load pressure switch adjusted at 0.5 bar  
 SC Plate heat exchanger  
 VSU Safety valve adjusted at 6 bar (only if pumps or valves are present)  
 VSR Exhaust valve  
 BTIS Entering temperature probe, source side (to remotely)

BTOS Leaving temperature probe, source side  
 BTIU Entering temperature probe, user side  
 BTOU Leaving temperature probe, user side  
 VNCS Natural Cooling valve, source side (provided by the Customer)  
 VNCU Natural Cooling valve, user side (provided by the Customer)  
 SCNC Natural Cooling exchanger (provided by the Customer)

## 10 Decommissioning

### 10.1 Disconnecting

Only authorised personnel must disconnect the unit.

Avoid leak or spills into the environment.

Before disconnecting the unit, the following must be recovered, if present:

- refrigerant gas
- anti-freeze solutions in the water circuit

Awaiting dismantling and disposal, the unit can also be stored outdoors, if the electrical, cooling and water circuits of the unit have 100% integrity and are isolated, bad weather and rapid change in temperature will not result in any environmental impact.

### 10.2 Dismantling and disposal

The unit must always be sent to authorised centres for dismantling and disposal.

When dismantling the unit, the fan, the motor and the coil, if operating, may be recovered by the specialist centres for reuse.

All the materials must be recovered or disposed of in compliance with the corresponding national standards in force.

For further information on the decommissioning of the unit, contact the manufacturer.

### 10.3 Directive EC RAEE

The manufacturer is registered on the EEE National Register, in compliance with implementation of Directive 2012/19/EU and relevant national regulations on waste electrical and electronic equipment.

This Directive requires electrical and electronic equipment to be disposed of properly.

Equipment bearing the crossed-out wheellie bin mark must be disposed of separately at the end of its life cycle to prevent damage to human health and to the environment.

Electrical and electronic equipment must be disposed of together with all of its parts.

To dispose of "household" electrical and electronic equipment, the manufacturer recommends you contact an authorised dealer or an authorised ecological area.

"Professional" electrical and electronic equipment must be disposed of by authorised personnel through established waste disposal authorities around the country.

In this regard, here is the definition of household WEEE and professional WEEE:

WEEE from private households: WEEE originating from private households and WEEE which comes from commercial, industrial, institutional and other sources which, because of its nature and quantity, is similar to that from private households. Subject to the nature and quantity, where the waste from EEE was likely to have been by both a private household and users of other than private households, it will be classed as private household WEEE;

Professional WEEE: all WEEE which comes from users other than private households.

This equipment may contain:

refrigerant gas, the entire contents of which must be recovered in suitable containers by specialised personnel with the necessary qualifications;

- lubrication oil contained in compressors and in the cooling circuit to be collected;
- mixtures with antifreeze in the water circuit, the contents of which are to be collected;
- mechanical and electrical parts to be separated and disposed of as authorised.

When machine components to be replaced for maintenance purposes are removed or when the entire unit reaches the end of its life and needs to be removed from the installation, waste should be separated by its nature and disposed of by authorised personnel at existing collection centres.



## 11 Residual risks

### General description

In this section the most common situations are indicated, as these cannot be controlled by the manufacturer and could be a source of risk situations for people or things.

### Danger zone

This is an area in which only an authorised operator may work.

The danger zone is the area inside the unit which is accessible only with the deliberate removal of protections or parts thereof.

### Handling

The handling operations, if implemented without all of the protection necessary and without due caution, may cause the drop or the tipping of the unit with the consequent damage, even serious, to persons, things or the unit itself.

Handle the unit following the instructions provided in the present manual regarding the packaging and in compliance with the local regulations in force. Should the refrigerant leak please refer to the refrigerant "Safety sheet".

### Installation

The incorrect installation of the unit could cause water leaks, condensate accumulation, leaking of the refrigerant, electric shock, poor operation or damage to the unit itself.

Check that the installation has been implemented by qualified technical personnel only and that the instructions contained in the present manual and the local regulations in force have been adhered to.

The installation of the unit in a place where even infrequent leaks of inflammable gas and the accumulation of this gas in the area surrounding the area occur could cause explosions or fires.

Carefully check the positioning of the unit.

The installation of the unit in a place unsuited to support its weight and/or guarantee adequate anchorage may result in consequent damage to things, people or the unit itself.

Carefully check the positioning and the anchoring of the unit.

Easy access to the unit by children, unauthorised persons or animals may be the source of accidents, some serious.

Install the unit in areas which are only accessible to authorised person and/or provide protection against intrusion into the danger zone.

### General risks

Smell of burning, smoke or other signals of serious anomalies may indicate a situation which could cause damage to people, things or the unit itself.

Electrically isolate the unit (yellow-red isolator).

Contact the authorised service centre to identify and resolve the problem at the source of the anomaly.

Accidental contact with exchange batteries, compressors, air delivery tubes or other components may cause injuries and/or burns.

Always wear suitable clothing including protective gloves to work inside the danger zone.

Maintenance and repair operations carried out by non-qualified personnel may cause damage to persons, things or the unit itself.

Always contact the qualified assistance centre.

Failing to close the unit panels or failure to check the correct tightening of all of the panelling fixing screws may cause damage to persons, things or the unit itself.

Periodically check that all of the panels are correctly closed and fixed.

If there is a fire the temperature of the refrigerant could reach values that increase the pressure to beyond the safety valve with the consequent possible projection of the refrigerant itself or explosion of the circuit parts that remain isolated by the closure of the tap.

Do not remain in the vicinity of the safety valve and never leave the refrigeration system taps closed.

### Electric parts

An incomplete attachment line to the electric network or with incorrectly sized cables and/or unsuitable protective devices can cause electric shocks, intoxication, damage to the unit or fires.

Carry out all of the work on the electric system referring to the electric layout and the present manual ensuring the use of a system thereto dedicated.

An incorrect fixing of the electric components cover may lead to the entry of dust, water etc inside and may consequently electric shocks, damage to the unit or fires.

Always fix the unit cover properly.

When the metallic mass of the unit is under voltage and is not correctly connected to the earthing system it may be as source of electric shock and electrocution.

Always pay particular attention to the implementation of the earthing system connections.

Contact with parts under voltage accessible inside the unit after the removal of the guards can cause electric shocks, burns and electrocution.

Open and padlock the general isolator prior to removing the guards and signal work in progress with the appropriate sign.

Contact with parts that could be under voltage due to the start up of the unit may cause electric shocks, burns and electrocution.

When voltage is necessary for the circuit open the isolator on the attachment line of the unit itself, padlock it and display the appropriate warning sign.

### Moving parts

Contact with the transmissions or with the fan aspiration can cause injuries.

Prior to entering the inside of the unit open the isolator situated on the connection line of the unit itself, padlock and display the appropriate warning sign.

Contact with the fans can cause injury.

Prior to removing the protective grill or the fans, open the isolator on the attachment line of the unit itself, padlock it and display the appropriate warning sign.

### Refrigerant

The intervention of the safety valve and the consequent expulsion of the gas refrigerant may cause injuries and intoxication.

Always wear suitable clothing including protective gloves and eyeglasses for operations inside the danger zone.

Should the refrigerant leak please refer to the refrigerant "Safety sheet".

Contact between open flames or heat sources with the refrigerant or the heating of the gas circuit under pressure (e.g. during welding operations) may cause explosions or fires.

Do not place any heat source inside the danger zone.

The maintenance or repair interventions which include welding must be carried out with the system off.

### Hydraulic parts

Defects in tubing, the attachments or the removal parts may cause a leak or water projection with the consequent damages to people, things or shortcircuit the unit.

## General technical data - OTH4 - Operating conditions above 4°C - Performance

| SIZE   |       | 12.2 | 16.2 | 19.2 | 22.2 | 27.2 | 35.2 | 40.2 | 45.2 | 55.2 | 60.2 | 70.2 | 80.2 |
|--|-------|------|------|------|------|------|------|------|------|------|------|------|------|
| <b>COOLING</b>   |       |      |      |      |      |      |      |      |      |      |      |      |      |
| Cooling capacity                                       | 1 kW  | 34,4 | 48,2 | 57,4 | 66,5 | 81,3 | 105  | 120  | 142  | 167  | 190  | 215  | 242  |
| Total power input                                      | 1 kW  | 7,34 | 10,3 | 12,0 | 14,8 | 17,2 | 22,9 | 26,0 | 30,7 | 36,8 | 41,5 | 47,0 | 53,3 |
| EER  | 1 kW  | 4,69 | 4,68 | 4,78 | 4,49 | 4,73 | 4,60 | 4,61 | 4,63 | 4,54 | 4,59 | 4,56 | 4,53 |
| Cold side exchanger water flow rate                    | 1 -   | 1,64 | 2,30 | 2,74 | 3,18 | 3,88 | 5,03 | 5,72 | 6,78 | 7,98 | 9,09 | 10,2 | 11,5 |
| Cold side exchanger pressure drop                      | 1 l/s | 30   | 37   | 32   | 42   | 28   | 25   | 32   | 27   | 36   | 31   | 39   | 34   |
| Source side exchanger water flow rate                  | 1 kPa | 1,99 | 2,80 | 3,32 | 3,88 | 4,71 | 6,13 | 6,97 | 8,25 | 9,74 | 11,1 | 12,5 | 14,1 |
| Source side exchanger pressure drop                    | 1 l/s | 29   | 40   | 51   | 70   | 22   | 36   | 28   | 38   | 35   | 45   | 39   | 49   |
| Cooling capacity (EN14511:2018)                        | 2 kPa | 34,3 | 48,0 | 57,2 | 66,2 | 81,0 | 105  | 119  | 142  | 166  | 190  | 214  | 241  |
| Total power input (EN14511:2018)                       | 3 kW  | 7,69 | 10,9 | 12,7 | 15,7 | 17,8 | 23,7 | 26,9 | 31,8 | 38,2 | 43,1 | 48,8 | 55,3 |
| EER (EN14511:2018)                                     | 4 kW  | 4,46 | 4,42 | 4,51 | 4,20 | 4,56 | 4,42 | 4,43 | 4,45 | 4,36 | 4,40 | 4,38 | 4,35 |
| SEER   | 11 -  | 5,30 | 4,85 | 4,84 | 4,85 | 5,05 | 5,17 | 5,31 | 5,29 | 4,93 | 4,92 | 5,00 | 4,82 |
| <b>HEATING</b>   |       |      |      |      |      |      |      |      |      |      |      |      |      |
| Heating capacity                                       | 5 kW  | 40,3 | 56,6 | 66,8 | 79,2 | 93,7 | 119  | 139  | 163  | 195  | 218  | 252  | 279  |
| Total power input                                      | 5 kW  | 9,02 | 12,4 | 14,5 | 17,4 | 20,3 | 26,8 | 30,7 | 36,3 | 43,3 | 48,9 | 54,9 | 61,5 |
| COP  | 5 -   | 4,47 | 4,56 | 4,61 | 4,55 | 4,62 | 4,46 | 4,51 | 4,48 | 4,50 | 4,45 | 4,59 | 4,53 |
| Hot side exchanger water flow rate                     | 5 l/s | 1,93 | 2,70 | 3,19 | 3,78 | 4,48 | 5,70 | 6,62 | 7,77 | 9,30 | 10,4 | 12,0 | 13,3 |
| Hot side exchanger pressure drop                       | 5 kPa | 27   | 37   | 48   | 66   | 30   | 48   | 38   | 51   | 47   | 58   | 49   | 60   |
| Source side exchanger water flow rate                  | 5 l/s | 2,49 | 3,52 | 4,16 | 4,92 | 5,84 | 7,37 | 8,58 | 10,1 | 12,1 | 13,4 | 15,7 | 17,3 |
| Source side exchanger pressure drop                    | 5 kPa | 43,7 | 62,2 | 80,1 | 111  | 32,8 | 50,5 | 41,3 | 55,6 | 53,0 | 65,2 | 61,0 | 74,0 |
| Heating capacity (EN14511:2018)                        | 6 kW  | 40,4 | 56,8 | 67,2 | 79,8 | 94,0 | 120  | 139  | 163  | 196  | 219  | 253  | 280  |
| Total power input (EN14511:2018)                       | 3 kW  | 9,42 | 13,2 | 15,6 | 19,0 | 21,1 | 28,2 | 32,0 | 38,2 | 45,3 | 51,5 | 57,6 | 65,0 |
| COP (EN14511:2018)                                     | 7 -   | 4,29 | 4,32 | 4,31 | 4,20 | 4,46 | 4,25 | 4,34 | 4,28 | 4,31 | 4,25 | 4,39 | 4,31 |
| ErP Space Heating Energy Class - AVERAGE Climate - W35 | 10    | A+++ | A+++ | -    | -    | -    | -    | -    | -    | -    | -    | -    | -    |
| SCOP - AVERAGE Climate - W35                           | 11    | 5,69 | 5,45 | 5,47 | 4,85 | 5,97 | 5,67 | 5,84 | 5,68 | 5,68 | 5,55 | 5,63 | 5,45 |
| ErP Space Heating Energy Class - AVERAGE Climate - W55 | 10    | A+++ | A+++ | A+++ | -    | -    | -    | -    | -    | -    | -    | -    | -    |
| SCOP - AVERAGE Climate - W55                           | 11    | 4,56 | 4,42 | 4,42 | 4,46 | 4,89 | 4,60 | 4,69 | 4,67 | 4,64 | 4,61 | 4,69 | 4,65 |
| <b>COOLING 100% - HEATING 100%</b>                     |       |      |      |      |      |      |      |      |      |      |      |      |      |
| Cooling capacity                                       | 8 kW  | 31,3 | 43,9 | 52,1 | 61,2 | 73,8 | 95,2 | 108  | 128  | 151  | 174  | 195  | 219  |
| Heating capacity                                       | 8 kW  | 40,4 | 56,4 | 66,7 | 78,8 | 94,4 | 123  | 139  | 165  | 195  | 223  | 251  | 282  |
| Total power input                                      | 8 kW  | 9,12 | 12,5 | 14,6 | 17,6 | 20,6 | 27,3 | 31,1 | 36,7 | 43,9 | 49,1 | 55,8 | 63,0 |
| Global efficiency                                      | 9 -   | 7,86 | 8,02 | 8,14 | 7,95 | 8,16 | 7,97 | 7,95 | 7,97 | 7,88 | 8,10 | 7,99 | 7,96 |
| Cold side exchanger water flow rate                    | 8 l/s | 1,49 | 2,10 | 2,49 | 2,92 | 3,52 | 4,55 | 5,16 | 6,11 | 7,22 | 8,33 | 9,32 | 10,5 |
| Cold side exchanger pressure drop                      | 8 kPa | 25   | 31   | 26   | 36   | 23   | 21   | 26   | 22   | 30   | 26   | 33   | 28   |
| Hot side exchanger water flow rate                     | 8 l/s | 1,93 | 2,69 | 3,19 | 3,76 | 4,51 | 5,85 | 6,65 | 7,86 | 9,32 | 10,7 | 12,0 | 13,5 |
| Hot side exchanger pressure drop                       | 8 kPa | 27   | 37   | 48   | 66   | 31   | 50   | 38   | 53   | 47   | 60   | 49   | 61   |

The Product is compliant with the Erp (Energy Related Products) European Directive. It includes the Commission delegated Regulation (EU) No 811/2013 (rate heat output ≤70 kW at specified reference conditions) and the Commission delegated Regulation (EU) No 813/2013 (rated heat output ≤400 kW at specified reference conditions).

'Contains fluorinated greenhouse gases'(GWP 2087,5)

1. Data referred to the following conditions: Cold side exchanger water temperature 12/7°C. Source side exchanger water temperature 30/35°C.
2. Data referred to the following conditions: Cold side exchanger water temperature 12/7°C. Source side exchanger water temperature 30/35°C. Performance data calculated with reference to EN14511:2018
3. The total power draw is calculated by adding the compressor's power draw + the draw required to overcome the internal service and source side pressure drops + the control circuit power draw
4. EER (EN 14511:2018) cooling performance coefficient. Ratio between delivered cooling capacity and power input in compliance with EN 14511:2018
5. Data referred to the following conditions: Hot side exchanger water temperature 40/45°C. Source side exchanger water temperature 10/7°C.
6. Data referred to the following conditions: Hot side exchanger water temperature 40/45°C Source side exchanger water temperature 10/7°C. Performance data calculated with reference to EN14511:2018
7. COP (EN 14511:2018) heating performance coefficient. Ratio between delivered heating capacity and power input in compliance with EN 14511:2018
8. Data referred to the following conditions: Temperatura acqua allo scambiatore lato freddo 12/7°C. Temperatura acqua allo scambiatore lato caldo 40/45°C.
9. Overall efficiency. Calculated as (cooling capacity delivered + heating capacity delivered)/(total power input).
10. Seasonal Space Heating Energy Efficiency Class according to Commission delegated Regulation (EU) No 811/2013. W = Water outlet temperature (°C)
11. Data calculated according to the EN 14825:2018 Regulation

## General technical data - OTH4 - Operating conditions above 4°C - Constructions

| SIZE                                   |       | 12.2     | 16.2     | 19.2     | 22.2     | 27.2     | 35.2     | 40.2     | 45.2     | 55.2     | 60.2     | 70.2     | 80.2     |
|--|-------|----------|----------|----------|----------|----------|----------|----------|----------|----------|----------|----------|----------|
| <b>COMPRESSOR</b>                      |       |          |          |          |          |          |          |          |          |          |          |          |          |
| Type of compressors                    |       | Scroll   |          |          |          |          |          |          |          |          |          |          |          |
| Refrigerant                            |       | R-410A   |          |          |          |          |          |          |          |          |          |          |          |
| No. of compressors                     | Nr    | 2        | 2        | 2        | 2        | 2        | 2        | 2        | 2        | 2        | 2        | 2        | 2        |
| Std Capacity control steps             | Nr    | 3        | 3        | 3        | 3        | 3        | 3        | 3        | 3        | 3        | 2        | 3        | 2        |
| Oil charge                             | l     | 3,0      | 5,8      | 5,8      | 5,8      | 6,6      | 8,0      | 10,1     | 11,0     | 13,1     | 12,6     | 12,6     | 12,6     |
| Refrigerant charge                     | kg    | 6,0      | 10,5     | 11,0     | 11,0     | 18,0     | 20,0     | 24,0     | 24,0     | 30,0     | 32,0     | 35,0     | 40,0     |
| Refrigeration circuits                 | Nr    | 1        | 1        | 1        | 1        | 1        | 1        | 1        | 1        | 1        | 1        | 1        | 1        |
| <b>COOLSIDE EXCHANGER</b>              |       |          |          |          |          |          |          |          |          |          |          |          |          |
| Type of exchanger                      | 1     | PHE      |          |          |          |          |          |          |          |          |          |          |          |
| No. of exchangers                      | Nr    | 1        | 1        | 1        | 1        | 1        | 1        | 1        | 1        | 1        | 1        | 1        | 1        |
| Water content                          | l     | 3,2      | 4,3      | 5,9      | 5,9      | 7,2      | 9,8      | 9,8      | 13,2     | 13,2     | 17,2     | 17,2     | 23,0     |
| <b>HEATING SIDE EXCHANGER</b>          |       |          |          |          |          |          |          |          |          |          |          |          |          |
| Type of exchanger                      | 1     | PHE      |          |          |          |          |          |          |          |          |          |          |          |
| No. of exchangers                      | Nr    | 1        | 1        | 1        | 1        | 1        | 1        | 1        | 1        | 1        | 1        | 1        | 1        |
| Water content                          | l     | 4,7      | 6,8      | 7,8      | 7,8      | 10,6     | 10,6     | 14,2     | 14,2     | 18,6     | 18,6     | 25,0     | 25,0     |
| <b>SOURCE SIDE EXCHANGER</b>           |       |          |          |          |          |          |          |          |          |          |          |          |          |
| Type of exchanger                      | 1     | PHE      |          |          |          |          |          |          |          |          |          |          |          |
| No. of exchangers                      | Nr    | 1        | 1        | 1        | 1        | 1        | 1        | 1        | 1        | 1        | 1        | 1        | 1        |
| Water content                          | l     | 4,7      | 6,8      | 7,8      | 7,8      | 9,8      | 9,8      | 13,2     | 13,2     | 17,2     | 17,2     | 23,0     | 23,0     |
| <b>CONNECTIONS</b>                     |       |          |          |          |          |          |          |          |          |          |          |          |          |
| Water fittings                         |       | 2"1/2    | 2"1/2    | 2"1/2    | 2"1/2    | 3"       | 3"       | 3"       | 3"       | 3"       | 3"       | 3"       | 3"       |
| <b>WATER CIRCUIT</b>                   |       |          |          |          |          |          |          |          |          |          |          |          |          |
| Maximum water side pressure            | 2 MPa | 1        | 1        | 1        | 1        | 1        | 1        | 1        | 1        | 1        | 1        | 1        | 1        |
| Minimum content cold side water system |       | 300      | 480      | 480      | 480      | 750      | 1000     | 1000     | 1000     | 1600     | 2050     | 2050     | 2650     |
| Minimum content hot side water system  |       | 300      | 470      | 470      | 470      | 730      | 950      | 950      | 950      | 1550     | 2000     | 2000     | 2550     |
| <b>POWER SUPPLY</b>                    |       |          |          |          |          |          |          |          |          |          |          |          |          |
| Standard power supply                  | V     | 400/3/50 | 400/3/50 | 400/3/50 | 400/3/50 | 400/3/50 | 400/3/50 | 400/3/50 | 400/3/50 | 400/3/50 | 400/3/50 | 400/3/50 | 400/3/50 |

1. PHE = plate exchanger

2. Conditions for the circuit on the cold side, hot side and the circuit on the source side. In configurations with hydronic units, the maximum pressure on the water side is 600 kPa.

## Sound levels

| SIZE | Sound power level (dB) |     |     |     |      |      |      |      | Sound power level<br>dB(A) | Sound pressure level<br>dB(A) |
|------|------------------------|-----|-----|-----|------|------|------|------|----------------------------|-------------------------------|
|      | Octave band (Hz)       |     |     |     |      |      |      |      |                            |                               |
|      | 63                     | 125 | 250 | 500 | 1000 | 2000 | 4000 | 8000 |                            |                               |
| 12.2 | 78                     | 69  | 62  | 56  | 52   | 44   | 43   | 38   | 60                         | 44                            |
| 16.2 | 78                     | 71  | 66  | 63  | 53   | 49   | 46   | 41   | 64                         | 49                            |
| 19.2 | 78                     | 73  | 67  | 63  | 55   | 51   | 47   | 42   | 65                         | 49                            |
| 22.2 | 78                     | 73  | 65  | 62  | 55   | 52   | 47   | 42   | 64                         | 49                            |
| 27.2 | 78                     | 73  | 66  | 62  | 56   | 54   | 49   | 44   | 64                         | 49                            |
| 35.2 | 81                     | 83  | 80  | 67  | 61   | 61   | 52   | 45   | 74                         | 58                            |
| 40.2 | 81                     | 79  | 80  | 67  | 65   | 63   | 55   | 50   | 74                         | 58                            |
| 45.2 | 81                     | 78  | 80  | 69  | 66   | 62   | 55   | 48   | 74                         | 58                            |
| 55.2 | 81                     | 80  | 83  | 70  | 68   | 65   | 57   | 50   | 77                         | 60                            |
| 60.2 | 81                     | 80  | 83  | 71  | 69   | 65   | 57   | 50   | 77                         | 61                            |
| 70.2 | 82                     | 80  | 85  | 73  | 72   | 68   | 60   | 51   | 79                         | 63                            |
| 80.2 | 82                     | 80  | 85  | 73  | 74   | 70   | 61   | 52   | 80                         | 63                            |

Sound levels refer to units with full load under nominal test conditions.

The sound pressure level refers to a distance of 1 meter from the outer surface of the unit operating in open field.

Noise levels are determined using the tensiometric method (UNI EN ISO 9614-2)

Data referred to the following conditions:

entering / leaving exchanger water temperature user side 12/7°C

entering / leaving exchanger water temperature source side 30/35°C

## Admissible water flow rates

Min. (Qmin) and max. (Qmax) water flow-rates admissibles for the correct unit operation.

| SIZE  |      |       | 12.2 | 16.2 | 19.2 | 22.2 | 27.2 | 35.2 | 40.2 | 45.2 | 55.2 | 60.2 | 70.2 | 80.2 |
|---|------|-------|------|------|------|------|------|------|------|------|------|------|------|------|
| Recovery side (2 pipe)<br>or<br>Heating side (4 pipe) | Qmin | [l/s] | 0,8  | 1,0  | 1,1  | 1,1  | 1,8  | 1,8  | 2,4  | 2,4  | 2,9  | 2,9  | 3,8  | 3,8  |
|   | Qmax | [l/s] | 4,2  | 4,8  | 4,9  | 5,1  | 8,8  | 9,3  | 11,4 | 12,2 | 15,0 | 15,4 | 18,3 | 19,0 |
| User side (2 tubi)<br>or<br>Cooling side (4 tubi)     | Qmin | [l/s] | 0,8  | 1,0  | 1,1  | 1,1  | 1,9  | 2,6  | 2,6  | 3,5  | 3,5  | 4,5  | 4,5  | 5,0  |
|   | Qmax | [l/s] | 3,5  | 4,4  | 4,9  | 5,1  | 8,5  | 11,5 | 11,5 | 14,5 | 15   | 18   | 18,5 | 21,5 |

## Overload and control device calibrations

|  |       | APRE | CHIUDE | VALORE |
|--|-------|------|--------|--------|
| High pressure switch (gas side)                      | [kPa] | 4050 | 3300   | -      |
| Low pressure alarm (gas side)                        | [kPa] | 450  | 600    | -      |
| Pressostato di bassa pressione (GEO) (lato gas)      | [kPa] | 200  | 350    | -      |
| Antifreeze protection                                | [°C]  | 4,0  | 6,0    | -      |
| High pressure safety valve (gas side)                | [kPa] | -    | -      | 4500   |
| Low pressure safety valve (gas side)                 | [kPa] | -    | -      | 3000   |
| Max no. of compressor starts per hour (gas side)     | [n°]  | -    | -      | 10     |
| Differential pressure switch (water side)            | [kPa] | 3    | 5      | -      |
| Max. pressure without hydronic assembly (water side) | [kPa] | -    | -      | 1000   |
| Max. pressure with hydronic assembly (water side)    | [kPa] | -    | -      | 600    |
| Safety valve calibration (water side) (1)            | [kPa] | -    | -      | 600    |

(1) Available only with hydronic assembly option

## Operating range - Cooling

Size 12.2

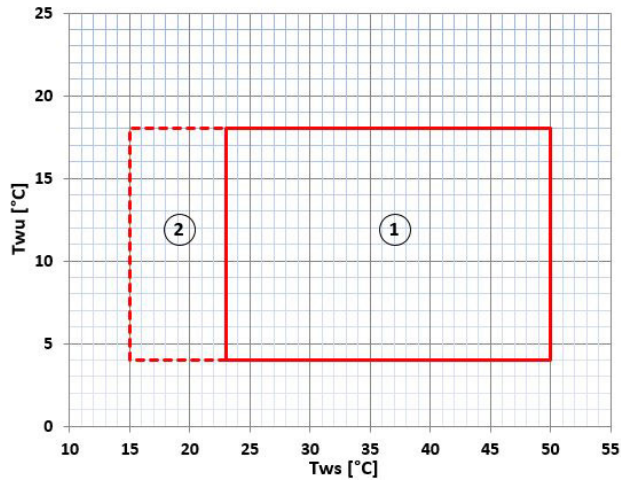

Size 16.2

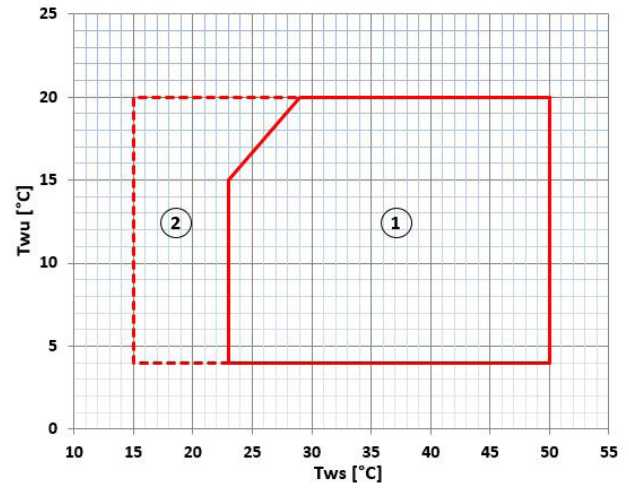

Size 19.2-22.2-27.2-35.2-40.2-45.2

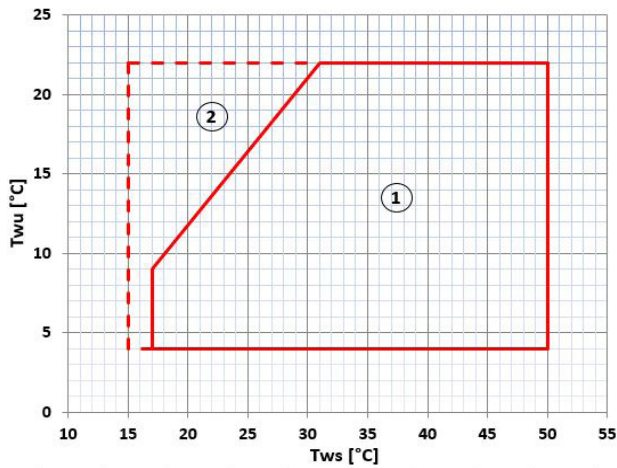

Size 55.2-60.2-70.2-80.2

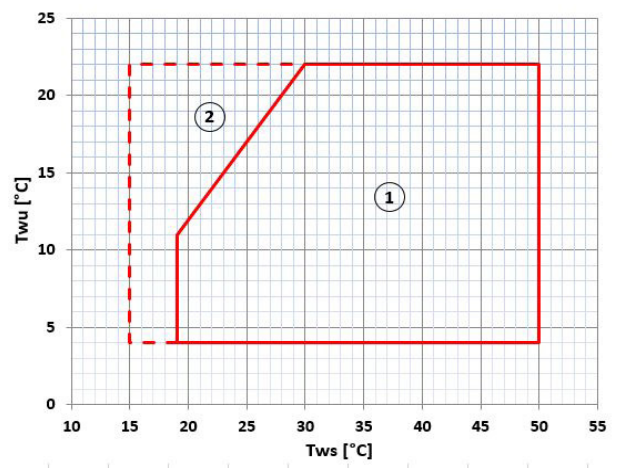

T<sub>wu</sub> [°C] = leaving water temperature user side

T<sub>ws</sub> [°C] = leaving water temperature source side

The limits refer to DT=5 °C on both the service and source sides

1. Normal operating range
2. Operating range with modulating valve on source side in regulation mode (optional configurations)

# Operating range - Heating - Operating range - Heating - OTH4 - Operating conditions above 4°C

Size 12.2

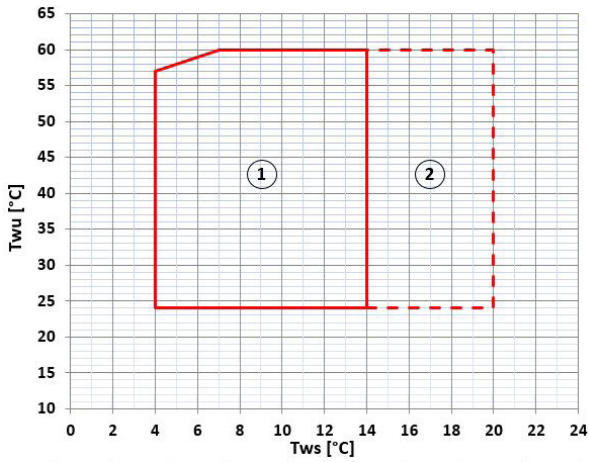

Size 16.2

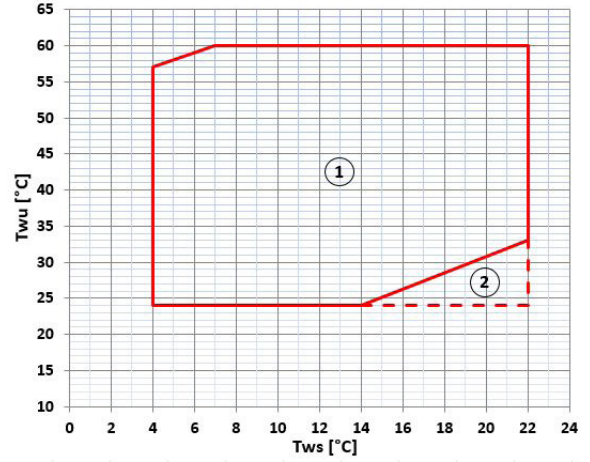

Size 19.2-22.2-27.2-35.2-40.2-45.2

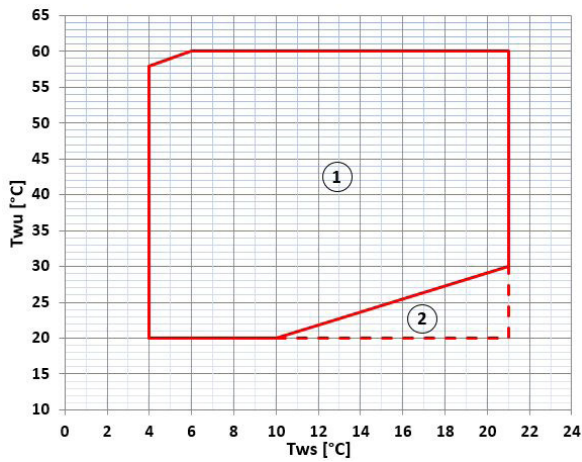

Size 55.2-60.2-70.2-80.2

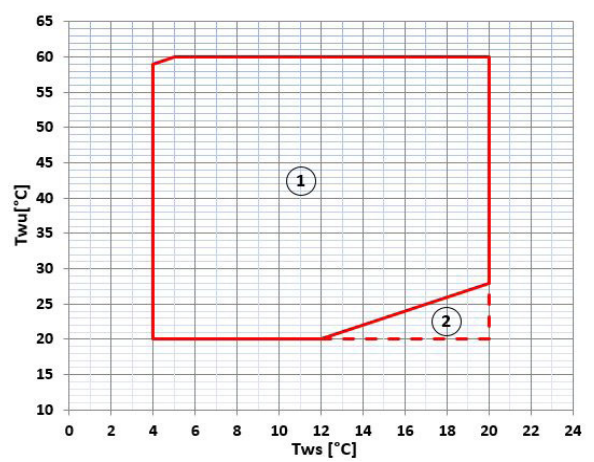

$T_{wu}$  [°C] = Leaving water temperature user side (2-pipe) or recovery side (4-pipe)  
 $T_{ws}$  [°C] = Leaving water temperature source side  
 The limits refer to  $DT=5$  °C user side, source side and recovery side

1. Normal operating range
2. Operating range where it is obligatory the use of water and glycol mixture depending on the outlet water temperature from the heat exchanger source side

## Operating range - Heating - OTL4 - Operating conditions below 4°C

Size 12.2

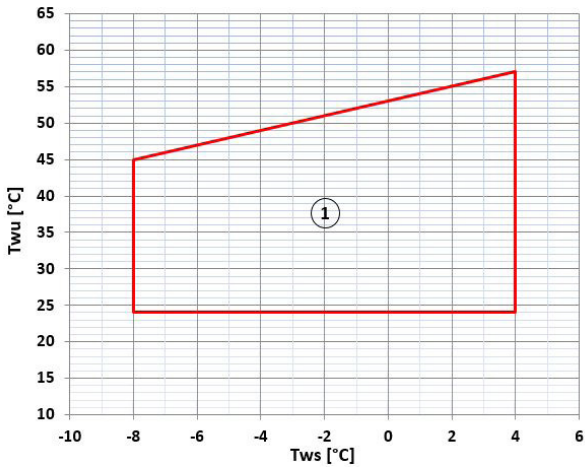

Size 16.2

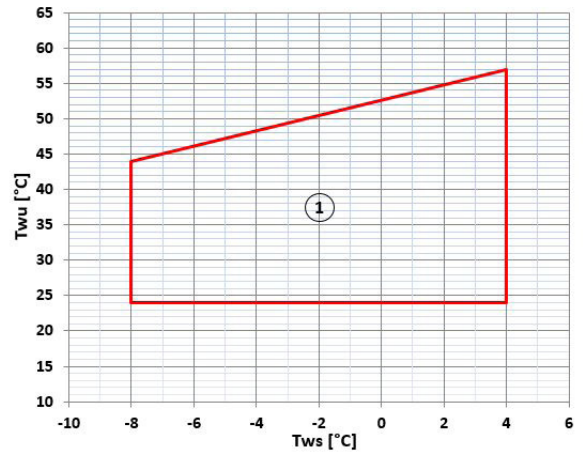

Size 19.2-22.2-27.2-35.2-40.2-45.2

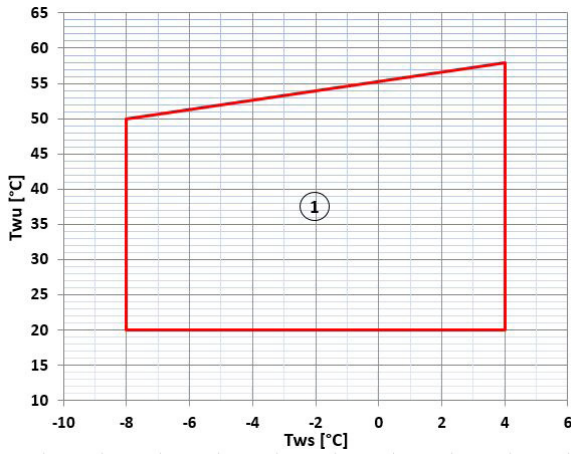

Size 55.2-60.2-70.2-80.2

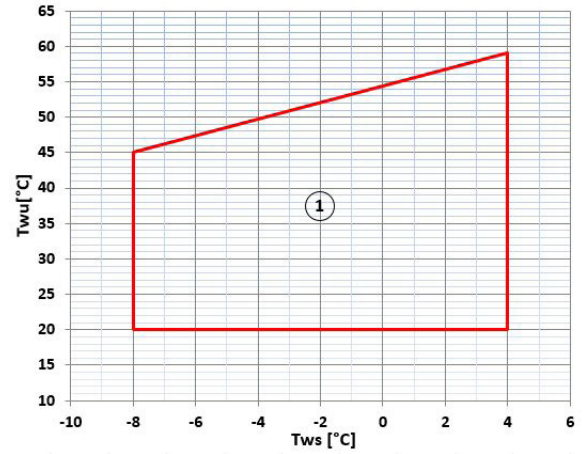

$T_{wu}$  [°C] = Leaving water temperature user side (2-pipe) or recovery side (4-pipe)

$T_{ws}$  [°C] = Leaving water temperature source side

The limits refer to  $\Delta T=5$ °C user side, source side and recovery side

1. Operating range with modulating valve on source side in regulation mode (optional configurations)

## Operating range - Cooling 100% - Heating 100%

Size 12.2

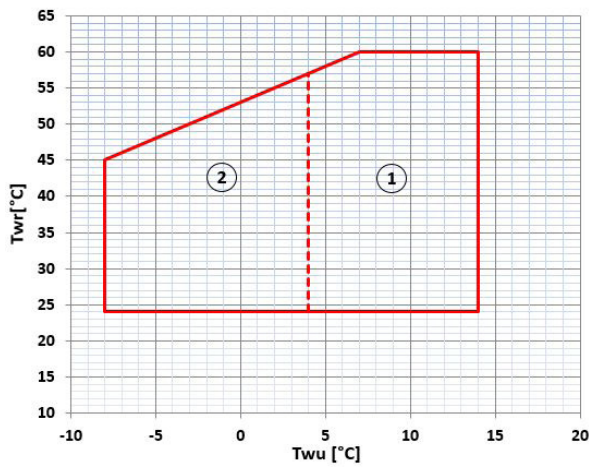

Size 16.2

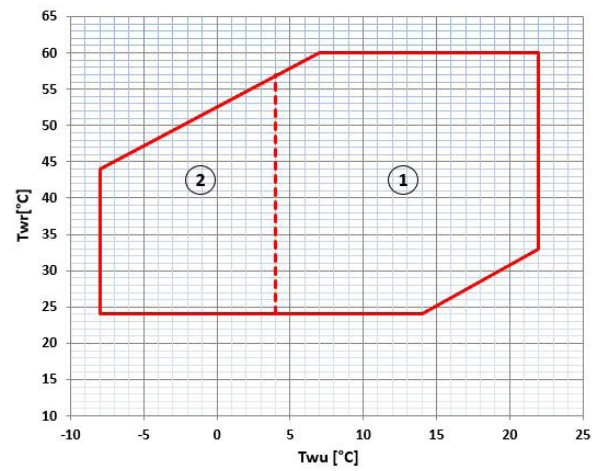

Size 19.2-22.2-27.2-35.2-40.2-45.2

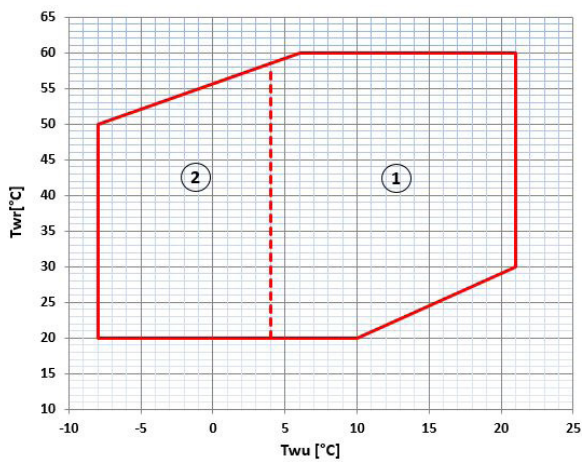

Size 55.2-60.2-70.2-80.2

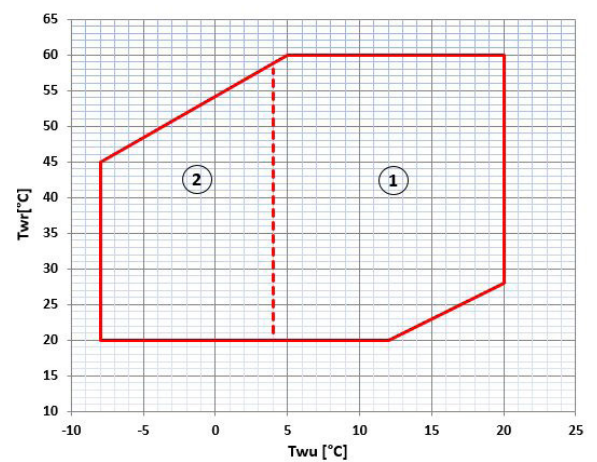

$T_{wu}$  [°C] = Leaving water temperature user side (2/4-pipe)  
 $T_{wr}$  [°C] = Leaving water temperature source side (2/4-pipe)  
 The limits refer to  $DT=5$  °C user side and source side

1. Normal operating range
2. Operating range where it is obligatory the use of water and glycol mixture depending on the outlet water temperature from the heat exchanger user side (2/4-pipe)

# Dimensional drawings

## Size 12.2 - 27.2

DAA8R10 2\_30 2  
26/03/2014 REV00

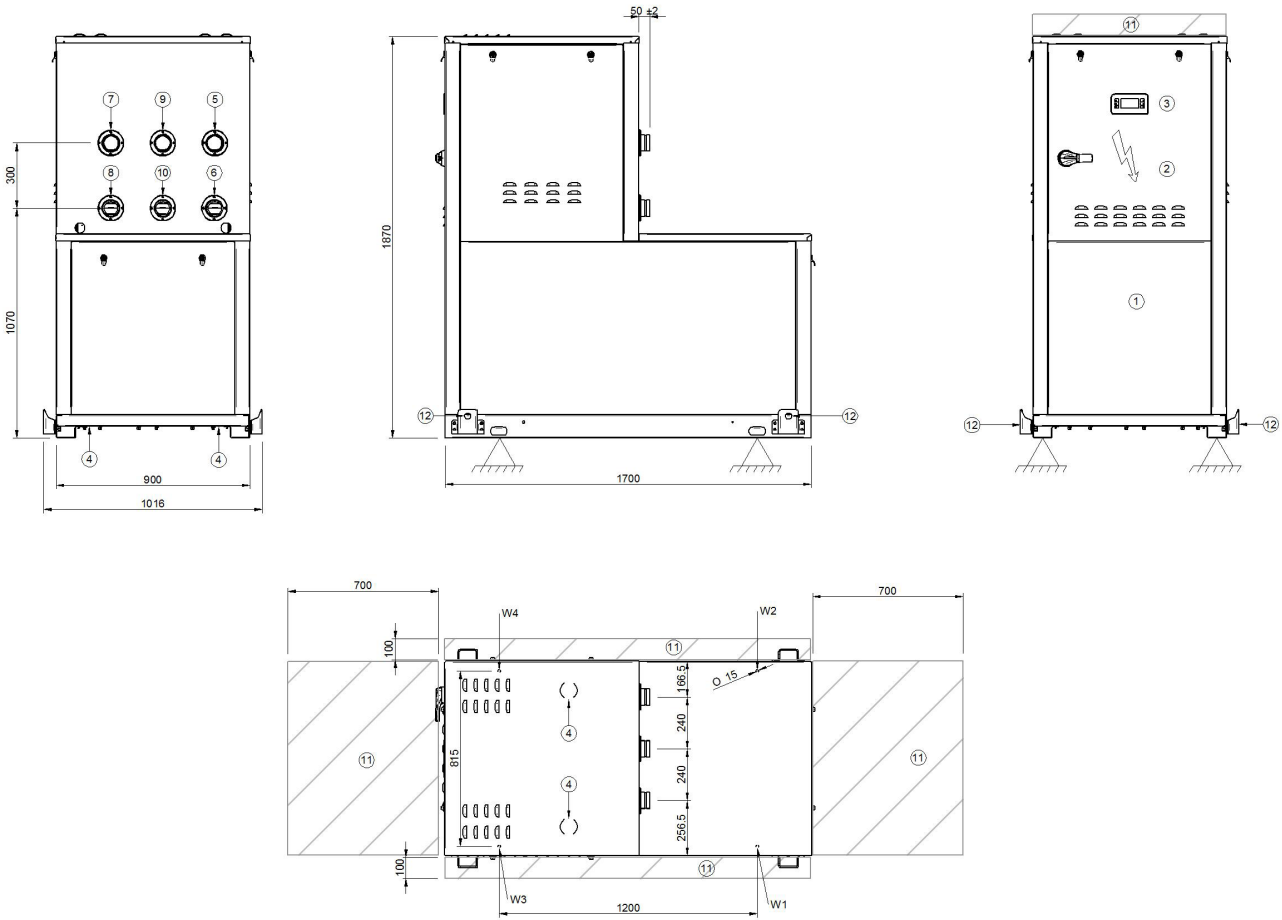

- 1. Compressor compartment
- 2. Electrical panel
- 3. Unit control keypad
- 4. Power input
- 5. Source side water return
- 6. Source side water supply
- 7. User side water return
- 8. User side water supply
- 9. Recovery side water return
- 10. Recovery side water supply
- 11. Functional spaces
- 12. Lifting brackets (removable)

| SIZE             |    | 12.2 | 16.2 | 19.2 | 22.2 | 27.2 |
|------------------|----|------|------|------|------|------|
| Length           | mm | 900  | 900  | 900  | 900  | 900  |
| Height           | mm | 1870 | 1870 | 1870 | 1870 | 1870 |
| Depth            | mm | 1700 | 1700 | 1700 | 1700 | 1700 |
| Operating weight | kg | 403  | 471  | 491  | 497  | 550  |
| Shipping weight  | kg | 364  | 419  | 433  | 439  | 489  |

The presence of optional accessories may result in a substantial variation of the weights shown in the table.



Page intentionally left blank

Page intentionally left blank

Page intentionally left blank

FOR OVER 30 YEARS, WE HAVE BEEN  
OFFERING SOLUTIONS TO ENSURE  
SUSTAINABLE COMFORT AND THE WELL-  
BEING OF PEOPLE AND THE ENVIRONMENT



sales and assistance

[www.clivet.com](http://www.clivet.com)



**CLIVET SPA**  
Via Camp Lonc 25, Z.I. Villapaiera  
32032 Feltre (BL) - Italy  
Tel. +39 0439 3131 - Fax +39 0439 313300  
[info@clivet.it](mailto:info@clivet.it)

A Group Company of

