



CSRN-XHE2 FFA

12.2-24.4

MANUAL

FOR INSTALLATION,
USE AND MAINTENANCE



M07Z40M15-03 02/2022

R-410A

Dear Customer,

We congratulate you on choosing these product

Clivet has been working for years to offer systems able to assure the maximum comfort for a long time with highly-reliable, efficient, high-quality and safe solutions. The target of the company is to offer advanced systems, that assure the best comfort and reduce energy consumption as well as the installation and maintenance costs for the entire life-cycle of the system.

With this manual, we want to give you information that are useful for all phases: from reception, installation and use to disposal - so that such an advanced system can provide the best performances during installation and use.

Best regards and have a good read.

CLIVET Spa

The data contained in this manual is not binding and may be changed by the manufacturer without prior notice. Reproduction, even partial, is FORBIDDEN. © Clivet S.p.A. - Feltre (BL) - Italia

INDEX

Safety considerations	4
Configurations	7
Reception	9
Selecting the installation site	11
Water connections	16
Aeraulic connections	19
Electrical connections	20
Start-up	25
Control	31
Maintenance	42
Decommissioning	49
Residual risks	50
Technical information	52

SAFETY CONSIDERATIONS

Safety

Operate in compliance with safety regulations in force.

Use single protection devices: gloves, glasses etc.

Manual

The manual provides correct unit installation, use and maintenance.

It is advisable to read it carefully so you will save time during operations.

Follow the written indications so you will not cause damages to things and injuries people.

Preliminaries

Only qualified personnel can operate on the unit, as required by the regulation in force.

Risk situations

The unit has been designed and created to prevent injuries to people.

During designing it is not possible to plane and operate on all risk situation.

Read carefully "Residual risk" section where all situation which may cause damages to things and injuries to people are reported.

Installation, starting, maintenance and repair required specific knowledge; if they are carried out by inexperienced personnel, they may cause damages to things and injuries people.

Intended use

Use the unit only:

- civil air-conditioning
- keep to the limits foreseen in the technical schedule and in this manual

The manufacturer accepts no responsibility if the equipment is used for any purpose other than the intended use.

Installation

Outdoor installation

The positioning, hydraulic system, refrigerating, electrics and the ducting of the air must be determined by the system designer in accordance with local regulations in force.

Follow local safety regulations.

Verify that the electrical line characteristics are in compliance with data quotes on the unit serial number label.

Maintenance

Plan periodic inspection and maintenance in order to avoid or reduce repairing costs.

Turn the unit off before any operation.



Pay particular attention to:

⇒ warnings / prohibitions / danger indicating particularly important operations or information, operations that cannot be done, which compromise the functionality of the unit or which may cause damage to things or persons.

Modification

All unit modifications will end the warranty coverage and the manufacturer responsibility.

Breakdown/Malfunction

Disable the unit immediately in case of breakdown or malfunction.

Contact a certified service agent.

Use original spares parts only.

Using the unit in case of breakdown or malfunction:

- voids the warranty
- it may compromise the safety of the unit
- it may increase time and repair costs

User training

The installer has to train the user on:

- start-up/shutdown
- set points change
- standby mode
- maintenance
- what to do / what not to do in case of breakdown.

Data update

Continual product improvements may imply manual data changes.

Visit manufacturer web site for updated data.

Indications for the User

Keep this manual with the wiring diagram in an accessible place for the operator.

Note the unit data label so you can provide them to the assistance centre in case of intervention (see “Unit identification” section).

Provide a unit notebook that allows any interventions carried out on the unit to be noted and tracked making it easier to suitably note the various interventions and aids the search for any breakdowns.

In case of breakdown or malfunction

- Immediately deactivate the unit
- Contact a service centre authorized by the manufacturer

The installer must train the user, particularly on:

- Start-up/shutdown
- Set points change
- Standby mode
- Maintenance
- What to do / what not to do in case of breakdown

Unit identification

The serial number label is positioned on the unit and allows to identify all the unit features.

The matriculation plate shows the indications foreseen by the standards, in particular:

- unit type
- serial number (12 characters)
- year of manufacture
- wiring diagram number
- electrical data
- type of refrigerant
- refrigerant charge
- manufacturer logo and address

The matriculation plate must never be removed.

It contains fluorinated greenhouse gases.

Serial number

It identifies uniquely each unit.

Must be quoted when ordering spare parts.

Refrigerant

It contains fluorinated greenhouse gases

Type of refrigerant: R410A

Assistance request

Note data from the serial number label and write them in the chart on side, so you will find them easily when needed.

Series
Size
Serial number
Year of manufacture
Number of electrical wiring diagram

CONFIGURATIONS

CBFFA configuration

Version with only supply

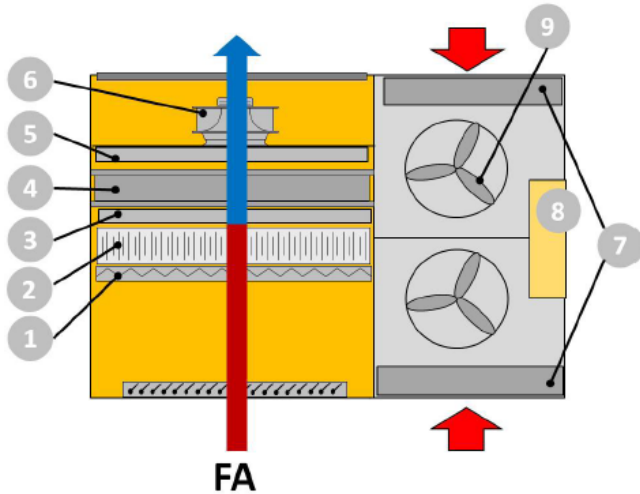

FA. Fresh air

S. Treated air supply

- 1 First filtration stage efficiency (G4 efficiency)
- 2 Second filtration stage *: F7 efficiency filter, F9 efficiency filter, electronic filter (E10 equivalent efficiency)
- 3 Heating with water coil or electric heaters *
- 4 Exchanger for air handling
- 5 Hot gas post-heating *
- 6 Supply fan section
- 7 Source side exchanger
- 8 Electrical panel
- 9 External fan section

* optional

CFFFA configuration

Version with extraction and exhaust

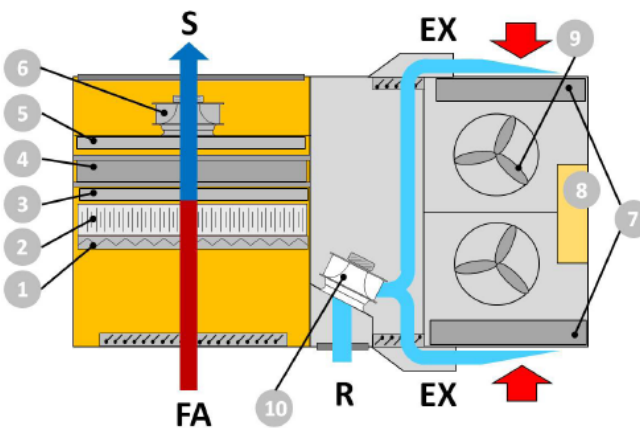

FA. Fresh air

S. Treated air supply

R. Air return

EX. Air exhaust

- 1 First filtration stage efficiency (G4 efficiency)
- 2 Second filtration stage *: F7 efficiency filter, F9 efficiency filter, electronic filter (E10 equivalent efficiency)
- 3 Heating with water coil or electric heaters *
- 4 Exchanger for air handling
- 5 Hot gas post-heating *
- 6 Supply fan section
- 7 Source side exchanger
- 8 Electrical panel
- 9 External fan section
- 10 Exhaust fan section

*optional

Supply and return configuration

Fresh air supply only: - CBFFA configuration

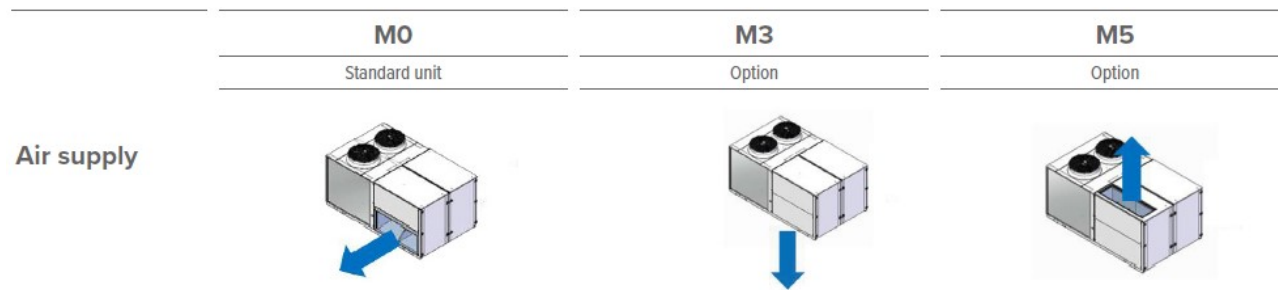

Fresh air supply with extraction and exhaust: CCFFA configuration

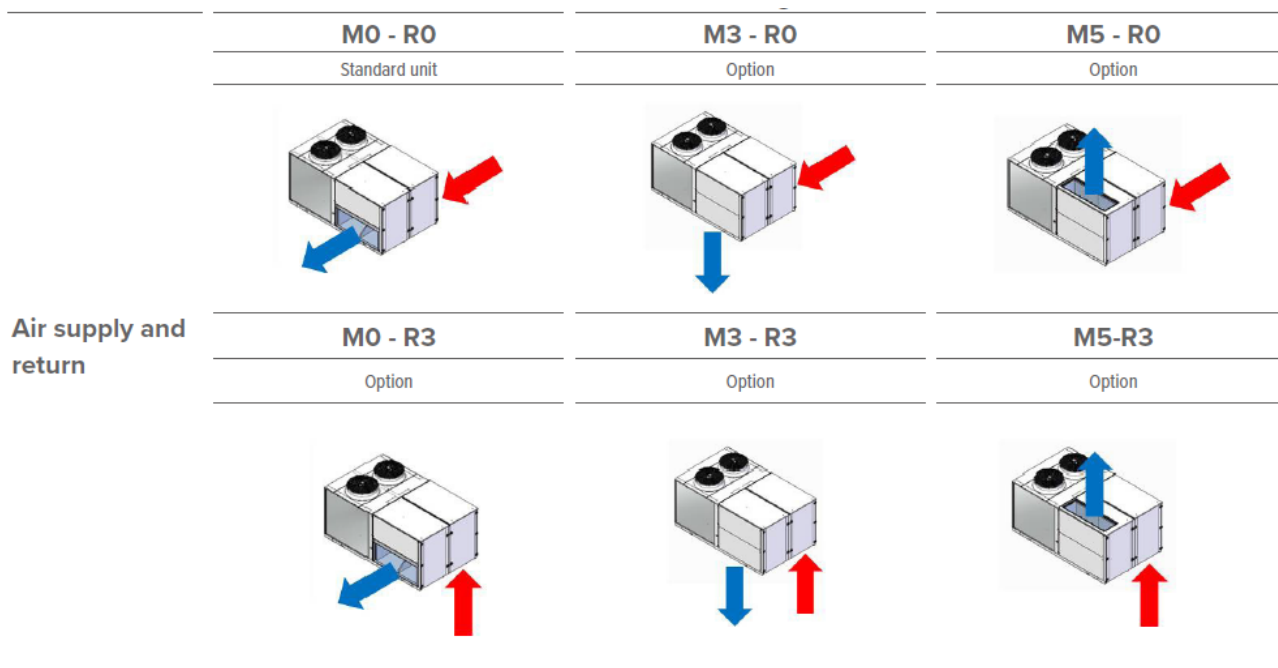

Filters nomenclature according to EN ISO 16890

1° filtering stage - standard	G4	ISO 16890 Coarse 60%
2° filtering stage - option	F7	ISO 16890 ePM1 55%
2° filtering stage - option	F9	ISO 16890 ePM1 80%
2° filtering stage - option	FES (electronic filters)	ISO 16890 ePM1 90%

RECEPTION

Safety

Operate in compliance with safety regulations in force.

For detailed information (dimensions, weight, technical characteristics etc.) please refer to the TECHNICAL INFORMATION section.

Use single protection devices: gloves, glasses etc.

Reception

You have to check before accepting the delivery:

- That the unit hasn't been damaged during transport
- That the materials delivered correspond with that indicated on the transport document comparing the data with the identification label positioned on the packaging.

In case of damage or anomaly:

- write down on the transport document the damage you found and quote this sentence: "Conditional acceptance clear evidence of deficiencies/damages during transport"
- contact by fax and registered mail with advice of receipt to supplier and the carrier.

NOTE

⇒ Any disputes must be made within 8 days from the date of the delivery. Complaints after this period are invalid .

Storage

Respect the indications on the outside of the pack.

In particular:

⇒ minimum ambient temperature -15°C
(possible components damages)

⇒ maximum ambient temperature $+49^{\circ}\text{C}$
(possible safety valve opening)

⇒ maximum relative humidity 95%
(possible damages to electrical components)

NOTE

⇒ The unit may not be tilted more than 15° during transport.

NOTE

Removal of packaging

Be careful not to damage the unit.

Recycle and dispose of the packaging material in compliance with local regulations.

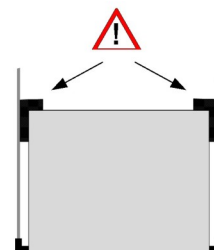
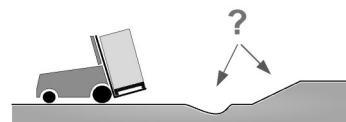

Handling

Caution

- ⇒ Check that all handling equipment complies with local safety regulations (cran, forklifts, ropes, hooks, etc.).
- ⇒ Provide personnel with personal protective equipment suitable for the situation, such as helmet, gloves, accident-prevention shoes, etc.
- ⇒ Observe all safety procedures in order to guarantee the safety of the personnel present and the of material.
- Verify unit weight and handling equipment lifting capacity.
- Identify critical points during handling (disconnected routes, flights, steps, doors).
- Suitably protect the unit to prevent damage.
- Lifting with balance (A)
- Lifting with spacer bar (B)
- Align the barycenter to the lifting point
- Gradually bring the lifting belts under tension, making sure they are positioned correctly.
- Before starting the handling, make sure that the unit is stable.

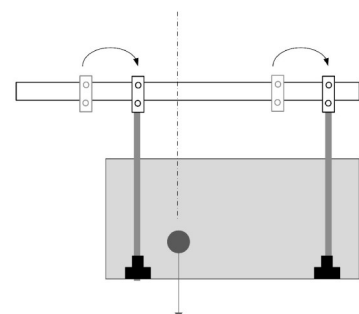
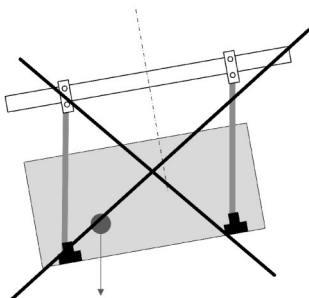
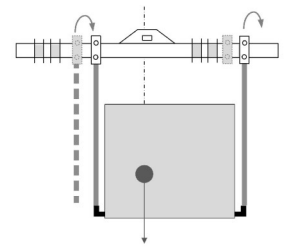
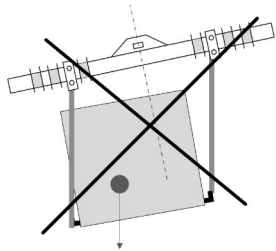
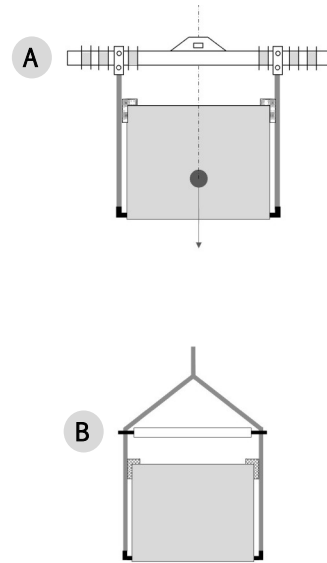
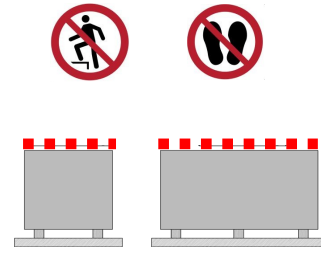

SELECTING THE INSTALLATION SITE

Positioning

⇒ Installation must be in accordance with local regulations. If they do not exist, follow EN378.

During positioning consider these elements:

- customer approval
- unit weight and bearing point capacity
- safe accessible position
- functional spaces
- spaces for the air intake/exhaust
- electrical connections
- max. distance allowed by the electrical connections
- water connections

Functional spaces

Functional spaces are designed to:

- guarantee good unit operation
 - carry out maintenance operations
 - protect authorized operators and exposed people
- ⇒ Respect all functional spaces indicated in the TECHNICAL INFORMATION section.

Positioning

Units are designed to be installed:

- EXTERNAL
- in fixed positions

⇒ Put the unit in a position where any leaking gas cannot enter buildings or stagnate in closed areas. In the latter case, observe the rules for machinery rooms (ventilation, leak detection, etc.).

Installation standards:

- install the unit raised from the ground
- bearing points aligned and leveled
- discharged condensation water must not cause harm/danger to people and property
- the accumulation of snow must not cause clogging of the coils
- avoid installations in places subject to flooding

Limit vibration transmission:

- use anti-vibration devices or neoprene strips on the unit support points
- install flexible joints on the hydraulic and aeraulic connections

Protect the unit with suitable fence in order to avoid access to unauthorised personnel (children, vandals, etc.)

A correct circulation of the air is mandatory to guarantee the good unit operating..

The unit must be level.

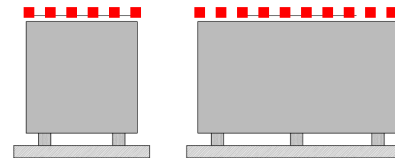
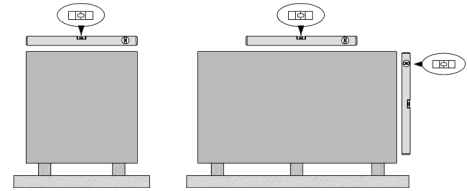

Concrete floor

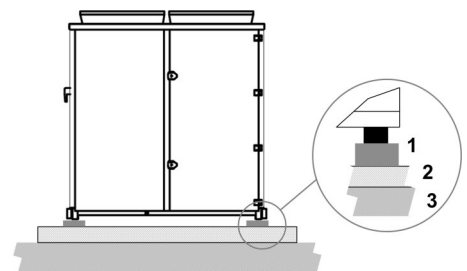

- 1 2 cm thick neoprene strips
- 2 concrete floor
- 3 floor

Steel structure

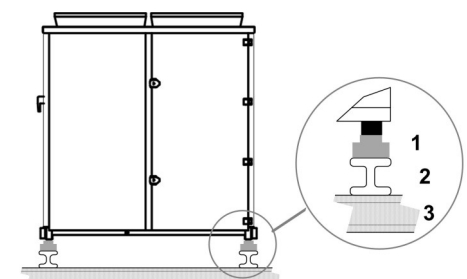

- 1 anti-vibration devices
- 2 steel structure
- 3 steel structure

Avoid therefore:

- obstacles to the airflow
- exchange difficulties
- leaves or other foreign bodies that can obstruct the exchange batteries
- winds that hinder or favour the airflow
- heat or pollution sources close to the unit (chimneys, extractors etc)
- stratification (cold air that stagnates at the bottom)
- recirculation (expelled air that is sucked in again)
- positioning below the level of the threshold, close to very high walls, attics or in angles that could give rise to stratification or recirculation phenomenons.

Ignoring the previous indications could:

- energy efficiency decrease
- alarm lockout due to HIGH PRESSURE (in summer) or LOW PRESSURE (in winter)

CBFFA, CCFFA configurations only

Avoid the accumulations of snow and ice in front of the exhaust air outlet.

CCFFA configurations only

Fix with 4 screws and washers each headphone.

Pressure relief valve gas side

The installer is responsible for evaluating the opportunity of installing drain pipes in compliance with the local regulations in force (EN 378).

If ducted, the valves must be sized according to EN13136 .

Only if electronic filter is present

The most common contaminants for which the filter is designed, are:

- air pollution by PM10, PM 2,5 and PM1

Contaminants that can be filtered:

- dry smokes
- powder (up to 0,3 microns)
- smoke electrostatically charged

Contaminants that can NOT be filtered:

- ⇒ *water vapors also in low concentration*
- ⇒ *oil vapors*
- ⇒ *large amounts of dust*
- ⇒ *metal shavings, iron filing dusts and waste generally*
- ⇒ *Gas*

Absolutely to avoid:

- ⇒ *metal dusts also fine*
- ⇒ *fumes produced by combustion of organic and not materials (wood, coal, gasoline, etc.)*

only CBFFA, CCFFA
Evitare accumuli di neve

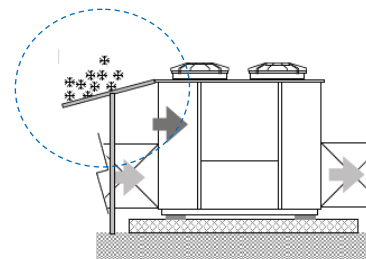
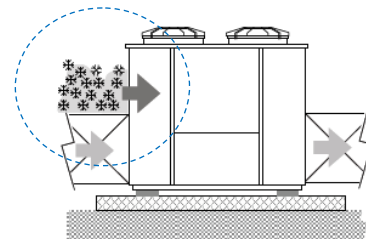

only CCFFA

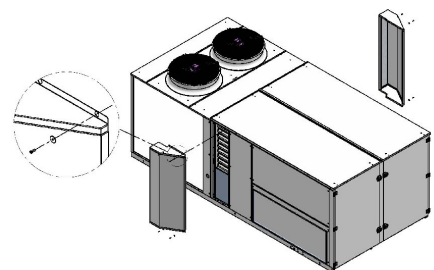

Gas heating module

Option

Burner with low pollutant emissions (NO_x below 80 mg/kWh), in line with Class 5 of the EN 676 European standard is supplied with a gas increase control for methane or LPG.

The heating module with burner includes:

- hot air generator powered with methane
- kit for transformation of power with liquefied petroleum gas (LPG)
- kit of steel chimney for exhaust fumes
- all the control and safety devices

⇒ *The component requires gas supply (gas connections to be made by the Customer).*

⇒ *The location of the unit and the fume drain mode must comply with laws and standards in force in the Country of use.*

⇒ *The Customer may choose the flue chimney.*

⇒ *The Customer is responsible for mounting the chimney kit during installation.*

⇒ *Based on the specific installation requirements, the length of the chimney can be increased with suitable joints and fittings (not supplied by Clivet).*

Gas connection

- Read the gas heating module manual.
- Connection must be carried out by qualified personnel.
- use certified components and comply with the local standards in force
- install on the gas connection: tap, large section filter and anti-vibration joint
- check the supply pressure is correct and stable, in particular where more uses are inserted on the same line.

System maintenance booklet

- It must be kept in the place of installation of the unit
- It must be filled-in upon commissioning
- It must be updated with the results of the periodical checks, of the routine and extraordinary maintenance interventions.

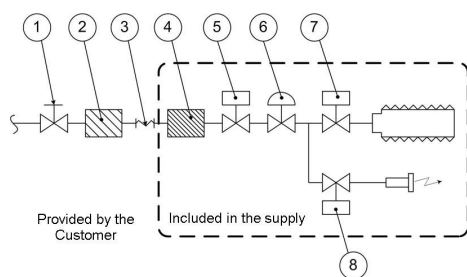

1. Gas shut-off valve
2. Gas filter (large section)
3. Anti-vibration joint
4. Gas filter (small section)
5. Safety gas solenoid valve
6. Pressure stabiliser
7. Main gas burner solenoid valve
8. Pilot burner gas solenoid valve

- A. Apply the flat adhesive gasket 15x5 on the Gas Module flange perimeter to guarantee the absence of air bypass.
- B. Fix with screws the flue supporting bracket to the GM frontal panel
- C. Fix the extensions with clamps to the flue supporting bracket
- D. Fix the suction terminals in ambient and the fuel components (curves, extensions, terminals) by the corresponding gaskets

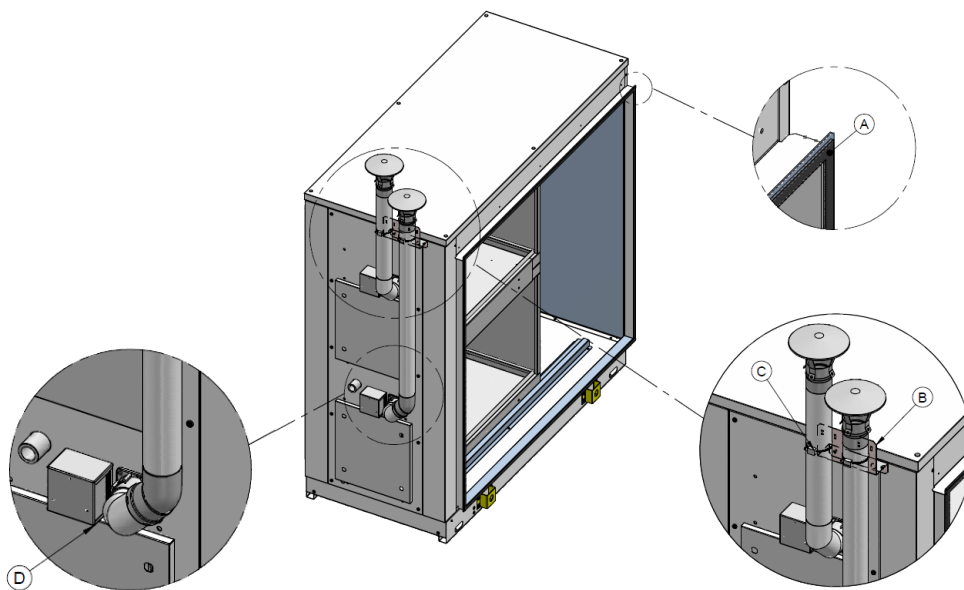

- 1 Approach the unit to the Gas Module.
- 2 match the supply flanges by means of the supplied terminals.
- 3 tighten screws
- 4 guarantee the absence of air bypass.

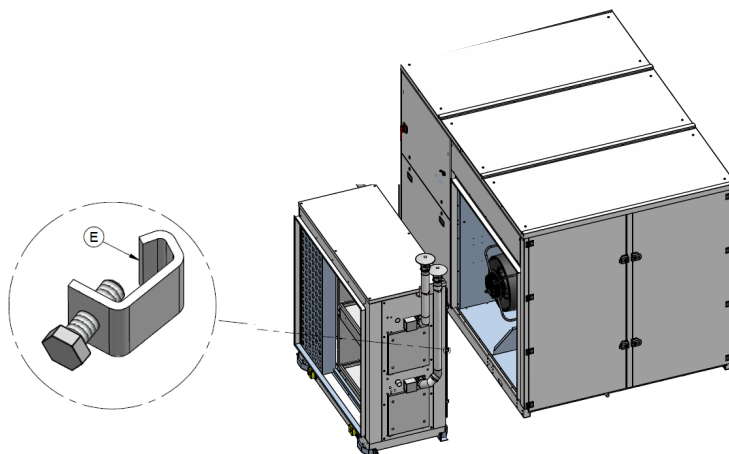

Connections performed by costumer

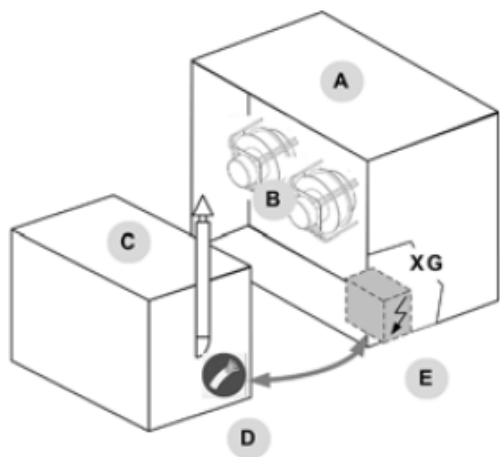

- A. rooftop
- B. supply fan
- C. gas module
- D. connecting cables
- E. electrical panel - terminal XG

Gas use features

		35kW		44kW		65kW		82kW	
		min	max	min	max	min	max	min	max
Rated thermal input	kW	7,6	34,8	8,50	42,0	12,4	65,0	16,4	82,0
Efficiency Hi (P.C.I.)	%	107,0	96,3	105,9	96,2	108,1	96,8	108,4	97,6
Efficiency Hs (P.C.S.)	%	96,4	86,8	95,4	86,7	97,4	87,2	97,6	87,9
Max condensation produced	l/h	0,9		1,1		2,1		3,3	
Carbon monoxide CO (0% di O2)	ppm	<5		<5		<5		<5	
Nitrogen oxides - NOx (0% di O2)		41 mg / kWh 23 ppm		35 mg / kWh 20 ppm		40 mg / kWh 23 ppm		34 mg / kWh 19 ppm	
Available flue pressure	Pa	90		90		120		120	
Gas connection diameter	GAS	UNI ISO 228/1 - G 3/4"		UNI ISO 228/1 - G 3/4"		UNI ISO 228/1 - G 3/4"		UNI ISO 228/1 - G 3/4"	
Exhaust pipe diameter	mm	80		80		80		80	
Seasonal space heating energy efficiency [EU Reg./2281/2016] [$\eta_{s,h}$]	%	92,1		90,8		93,2		93,2	
Emission efficiency [EU Reg./2281/2016] [$\eta_{s,flow}$]	%	97,3		97,0		97,4		97,1	
Power supply pressure (for gas G20)	mbar	20 [min 17-max 25]							
Gas consumption @15°C - 1013 mbar (for G20 gas)	m³/h	0,8	3,69	0,9	4,44	1,31	6,88	1,74	8,68

WATER CONNECTIONS

Condensate drain

The condensate must be disposed in order to avoid damages to people and things.

- Unit discharge fitting: the connection must not transmit mechanical stresses and must be performed taking care not to damage the unit discharge fitting.
- Provide a siphon that, eliminating the negative pressure caused by the fan, prevents the air intake from the discharge duct.
- The connection between the attachment and the siphon must be hermetically sealed (A)
- The piping must have adequate slope to allow out flow.
- Anchor the ducting with an adequate number of supports. Otherwise are generated duct failures and air locks that prevent the runoff.
- Insulate the duct and the siphon to avoid the condensate drippings.
- Connect the condensate discharge to a sewerage drainage network.
- DO NOT use white water or drainage networks to avoid the aspiration of odours in the case of evaporation of water contained in the siphon.
- Check at the end of the work, the regular condensate runoff pouring some water in the tray.

Siphon height calculation

$$T = 2P$$

$$S = T/2$$

P is the pressure determined by the fan in correspondence of the condense collection bowl (approx. 1 mm = 9.81 Pa)

Example :

$$P = 300 \text{ Pa} = 30 \text{ mm}$$

$$T = 2P = 60 \text{ mm}$$

$$S = T/2 = 30 \text{ mm}$$

Condensation in winter operation

When a heat pump is running it produces a considerable amount of water due to the defrosting cycles of the external coil.

The condensate must be disposed in order to avoid damages to people and things.

Risk of freezing

Prevent the risk of freeze if the unit, drain or plumbing connections can be subject to temperatures close to 0°C.

- isolate the piping
- protect the piping with heating cables laid underneath the insulation

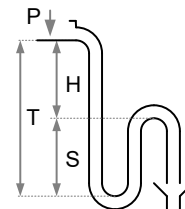
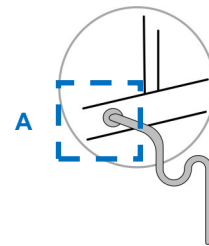

Immersed electrode humidifier

Option

Connexion humidificateur: 1/2" M

Supply water

The humidifier must be supplied with mains water having the following features:

- pressure between 0.1 and 0.8 Mpa (1 – 8 bar)
- temperature between 1 and 40°C

Do not use:

- water treated with softeners: it can corrode the electrodes and form foam with possible faults/malfunctionings
- pit, industrial or potentially polluted (chemically or bacteriologically) water
- disinfectants or anti-corrosive substances mixed with water, as potentially irritating

Supplying the humidifier with water treated with reverse osmosis filtering system gives the following advantages:

- reduces limescale deposits
- reduces energy consumptions
- reduces maintenance costs
- increases humidifier duration

Check that the filter guarantees a water flow rate higher than the flow rate of the installed humidifier.

Limit values for the supply water

Respect the limits indicated in the table

No relation can be demonstrated between water hardness and conductivity.

Limit values for the supply water	conductivity	medium-low		medium-high	
		min	max	min	max
Hydrogen ions	pH	7	8,5	7	8,5
Specific conductivity at 20°C	µS/cm	125	500	300	1250
Total dissolved solids	TDS mg/l	(1)	(1)	(1)	(1)
Dry residue at 180°C	R ₁₈₀ mg/l	(1)	(1)	(1)	(1)
Total hardness	TH mg/l CaCO ₃	50 ⁽²⁾	250	100 ⁽²⁾	400
Temporary hardness	mg/l CaCO ₃	30 ⁽³⁾	150	60 ⁽³⁾	300
Iron + Manganese	mg/l Fe+Mn	0	0,2	0	0,2
Chlorides	ppm Cl	0	20	0	30
Silica	mg/l SiO ₂	0	20	0	20
Residual chlorine	mg/l Cl ⁻	0	0,2	0	0,2
Calcium sulphate	mg/l CaSO ₄	0	60	0	100
Metallic impurities	mg/l	0	0	0	0
Solvents, diluents, soaps, lubricants	mg/l	0	0	0	0

(1) Values depending on specific conductivity; in general:

$$TDS \cong 0,93 * \sigma_{20}; R_{180} \cong 0,65 * \sigma_{20}$$

(2) not lower than 200% of the chloride content in mg/l of Cl⁻

(3) not lower than 300% of the chloride content in mg/l of Cl⁻

Drainage water

It can reach a temperature of 100°C.

It contains the same substances of the supply water but in higher concentration.

As it is not toxic, it can be disposed of with white waters.

Heating coil

Option

Max. operating pressure = 10 bar

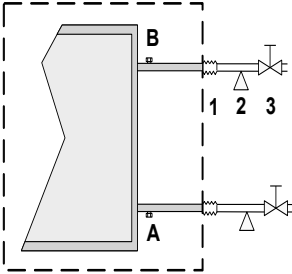

A drain valve

B vent valve

Provided by the customer:

1 anti-vibration devices

2 piping supports

3 Shut-off valves

AERAILIC CONNECTIONS

The dimensioning and correct execution of the aeraulic connections are fundamental to guarantee good unit operation and adequate level of silence in the room.

When designing and manufacturing the ducting, consider LOAD LOSSES, AIR FLOW AND SPEED that must be consistent with the unit features.

Particularly consider that load losses higher than the unit useful prevalence, lead to reduction in flow rate, with consequent unit blocks.

- the weight of the channels must not burden on the connection flanges
- place anti-vibration joints between channels and unit
- connection to the flanges and between the various sections of the channels must guarantee air seal, avoiding dispersions penalising the overall efficiency of the system
- limit the load losses by optimising the path, the type and number of bends and junctions
- use wide bends evaluating the opportunity of equipping them with deflectors (in particular with high air speed or bends with reduced radius)

Treated air channelling

The internal surface of the channel must be smooth, enable its washing and must not contaminate the air.

Thermally isolate the channels and the flanges to avoid energy losses and forming of condensation.

DIFFUSERS INLETS GRILLES

A correct diffusion of the air in the room is determining for the level of comfort.

When choosing and positioning the grilles, inlets and diffusers, avoid:

- excessive air speed
- forming of stagnant and stratification areas
- cold air delivery in room
- forming of localised currents (also due to uneven distribution of air)
- excessive room temperature variations, vertically and horizontally
- short circuits of the supply air towards the return air

For sound comfort, consider that:

- the air diffusers must be chosen verifying the sound power generated at nominal flow rate conditions
- the cut-off to diffusers must be carried out with flexible elements
- the return grilles must be widely dimensioned

Isolate the channels

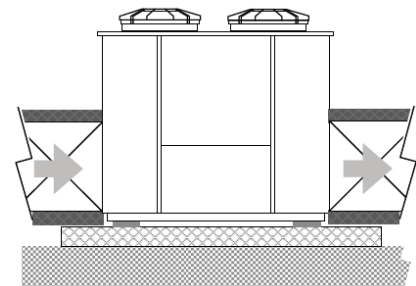

Isolate the flanges

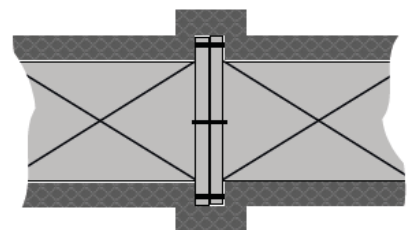

ELECTRICAL CONNECTIONS

The characteristics of the electrical lines must be determined by specialized personnel able to design electrical installations; moreover, the lines must be in conformity with regulations in force.

The protection devices of the unit power line must be able to stop the presumed short circuit current, whose value must be determined in function of system features.

The power cables and the protection cable section must be defined in accordance with the characteristics of the protections adopted.

All electrical operations should be performed by trained personnel having the necessary requirements by the regulations in force and being informed about the risks relevant to these activities.

Operate in compliance with safety regulations in force.

Electrical data

The serial number label reports the unit specific electrical data, included any electrical accessories.

The electrical data indicated in the technical bulletin and in the manual refer to the standard unit, accessories excluded.

Refer to the electrical data report on the serial number label:

- Tensione
- F.L.A.: full load ampere, absorbed current at maximum admitted conditions
- F.L.I.: full load input, full load power input at max. admissible condition
- Electrical wiring diagram Nr

Connections

refer to the unit electrical diagram (the number of the diagram is shown on the serial number label).

verify that the network has characteristics conforming to the data shown on the serial number label.

Before starting work, verify that the sectioning device at the start of the unit power line is open, blocked and equipped with cartel warning.

Primarily you have to realize the earthing connection.

Shelter the cables using adequate measure fairleads.

Before power the unit, make sure that all the protections that were removed during the electrical connection work have been restored.

Power supply network requirements

- 1 The short circuit capacity of the line must be less than 15 kA
- 2 The units can only be connected to TN, TT distribution systems
- 3 Voltage 400-3-50 +/-10%
- 4 Phase unbalance < 2%
- 5 Harmonic distortion less than 12% (THDv<12%)
- 6 Voltage interruptions lasting no longer than 3ms and with at least 1 s between each one
- 7 Voltage dips not exceeding 20% of the RMS value, lasting no longer than a single period (50Hz) and with at least 1 s between each dip.
- 8 Earth cable as specified in the table:

Cross-section of the line conductors (mm ²)	Minimum cross-section of the protective conductor (PE) (mm ²)
$S \leq 16$	S
$16 < S \leq 35$	16
$S > 35$	S/2

Signals / data lines

Do not overpass the maximum power allowed, which varies, according to the type of signal.

Lay the cables far from power cables or cables having a different tension and that are able to emit electromagnetic disturbances.

Do not lay the cable near devices which can generate electromagnetic interferences.

Do not lay the cables parallel to other cables; cable crossings are possible, only if laid at 90°.

Connect the screen to the ground, only if there aren't disturbances.

Guarantee the continuity of the screen during the entire extension of the cable.

Respect impedance, capacity and attenuation indications.

Power input

Fix the cables: if vacated may be subject to tearing.

The cable must not touch the compressor and the refrigerant piping (they reach high temperatures).

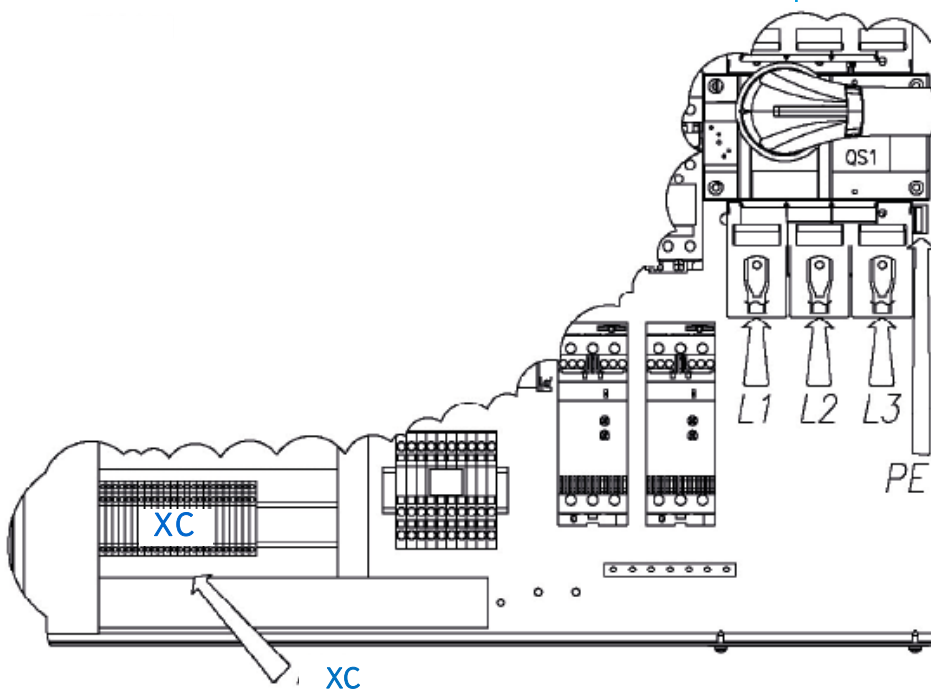

XC
Terminal block connections
by the customer

Connections performed by costumer

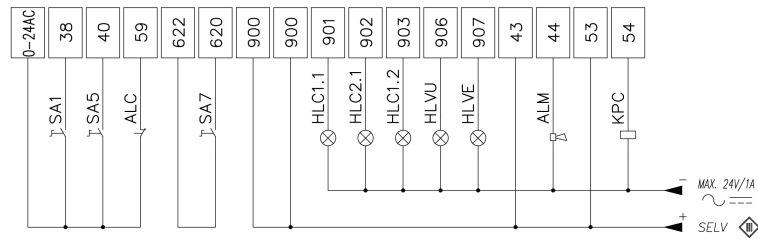

- ALC Free contact from signalling system of fire alarm
- ALM Cumulative fault signal
- KPC Pump control - available only if the unit is equipped with a hot water integration coil
- HLC1.1..2.2 Compressor status signal lamp
- HLVE Indicating light of the return and/or supply fan status
- HLVU Indicating light of the supply fan status
- SA1 Remote ON/OFF selector
- SA5 Settable input (mode change / Fan only)
- SA7 Enabling selector to the umidifier manual discharge

SA5 input

SA5: Summer / Winter mode remote change

P1010 =

- 0 - enabled by keypad
- 1 - enabled by SA5*
- 2 - enabled by BMS

* Fan-only function from SA5 not available

Function Fan only

P2323 =

- 0 - disabled
- 1 - enabled by BMS
- 2 - enabled by SA5*

* SUMMER - WINTER change mode by SA5 not available

Wall mounted room control

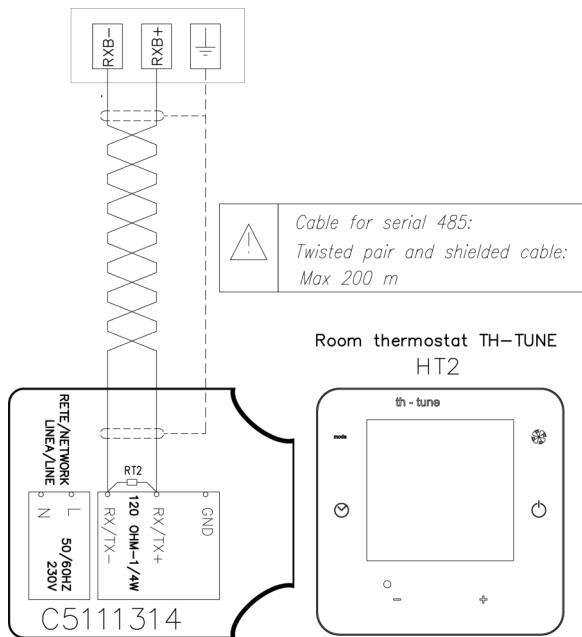

* RT2 Bus termination heater 120 Ohm - 1/4W
Mandatory installation to be borne by the customer.

Remote ambient air temperature probe.

HT1.1

Option

Allows adjustment of the unit with a temperature probe located at a suitable point of the room to detect the conditions at rest.

This solution can be used as an alternative either to the probes in the user interface and be located in a technical room other than the room to be air conditioned, or to the probes on the return line of the unit.

The probe can be located a maximum of 200 m away from the unit (cables not included in supply).

Option provided separately, electrical connection to be performed by the customer (recommended cables: for power supply at 24V PUR/PVC 2x0,75mm², fire resistant and with double insulation, to be laid separately from other signal/power cables, and shielded and twisted 485 serial cable).

Remote ambient air temperature and humidity probe.

HT1.1

Option

Details as indicated above.

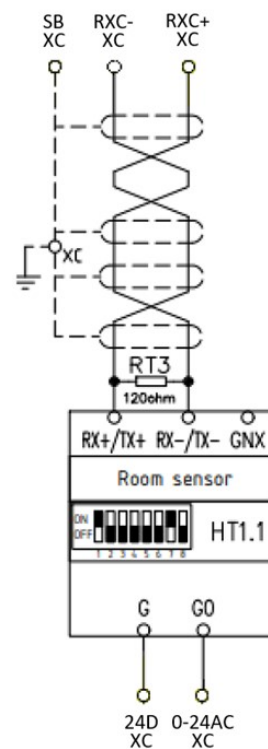
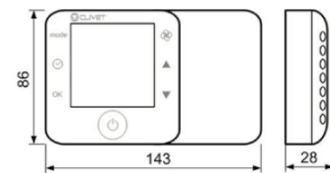
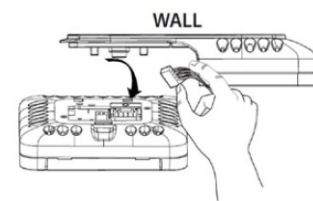
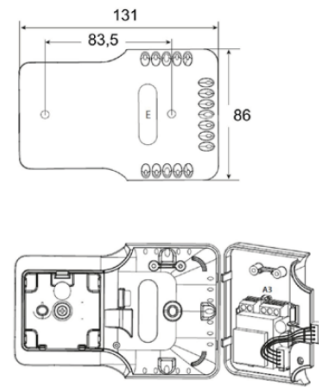

Serial communication module

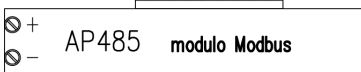
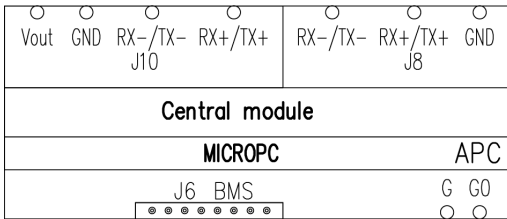

Modbus

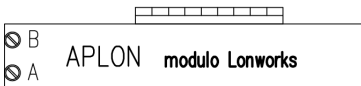

LonWorks

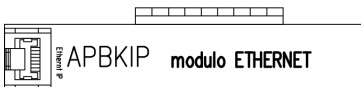

BACnet

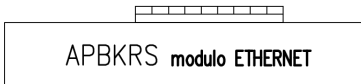

BACnet MSTP RS485

Serial communication module

Every RS485 serial line must be set up using the 'In/Out' bus system.

The difference in potential between the earth of the two RS485 devices that the cable shielding needs to be connected to must be lower than 7 V

There must be suitable arresters to protect the serial lines from the effects of atmospheric discharges

A 120 ohm resistance must be located on the end of the serial line. Alternatively, when the last serial board is equipped with an internal terminator, it must be enabled using the specific jumper, dip switch or link.

The cable must have insulation features and non-flame propagation in accordance with applicable regulations.

The RS485 serial line must be kept as far away as possible from sources of electromagnetic interference.

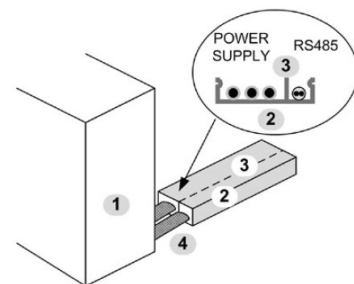

- 1 Unit
- 2 Metal conduit
- 3 Metal septums
- 4 Metal-lined sheath (sleeve)

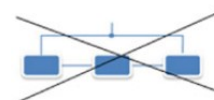

START-UP

The indicated operations should be done by qualified technician with specific training on the product.

Upon request, the service centres performing the start-up.

The electrical, water connections and the other system works are by the installer.

Agree upon in advance the star-up data with the service centre.

Before checking, please verify the following:

- the unit should be installed properly and in conformity with this manual
 - the electrical power supply line should be isolated at the beginning
 - the unit isolator is open, locked and equipped with the suitable warning
 - make sure no tension is present
- ⇒ *After turning off the power, wait at least 5 minutes before accessing to the electrical panel or any other electrical component.*
- ⇒ *Before accessing check with a multimeter that there are no residual stresses.*

Preliminary checks

For details refer to the different manual sections.

Unit OFF power supply

- 1 safety access
- 2 functional spaces
- 3 air flow: correct return and supply (no bypass, no stratification)
- 4 structure integrity
- 5 fans run freely
- 6 unit on vibration isolators
- 7 condensate drain
- 8 air filters present and clean
- 9 completed aeraulic system
- 10 refrigerant circuit visual check
- 11 earthing connection
- 12 power supply features
- 13 electrical connections provided by the customer



Start-up sequence

For details refer to the different manual sections.

Unit ON power supply

- 1 compressor crankcase heaters operating at least since 8 hours
- 2 off-load voltage measure
- 3 phase sequence check
- 4 shut-off valve refrigerant circuit open
- 5 unit ON
- 6 load voltage measure and absorptions
- 7 liquid sight glass check (no bubbles)
- 8 check all fan operating
- 9 check air flow on outer coil (no by-pass, no stratification)
- 10 air flow rate measurement
- 11 supply, return and outdoor air temperature measurement
- 12 measure super-heating and sub-cooling
- 13 check no anomalous vibrations are present
- 14 climatic curve personalization
- 15 climatic curve personalization
- 16 scheduling personalization
- 17 fire alarm configuration *
- 18 complete and available unit documentation

* only if present

Refrigeration circuit

- 1 Check carefully the refrigerating circuit: the presence of oil stains can mean leakage caused by transportation, movements or other).
- 2 Verify that the refrigerating circuit is in pressure: Using the unit manometers, if present, or service manometers.
- 3 Make sure that all the service outlets are closed with proper caps; if caps are not present a leak of refrigerant can be possible.
- 4 Open the valves of the refrigerant circuit, if there are any.

Water circuit

Only with humidifier options - Hot water coil

- 1 Before realizing the unit connection make sure that the hydraulic system has been cleaned up and the cleaning water has been drained.
- 2 Check that the water circuit has been filled and pressurized.
- 3 Check that the shut-off valves in the circuit are in the "OPEN" position.
- 4 Check that there isn't air in the circuit, if required, evacuate it using the air bleed valve placed in the system high points.
- 5 When using antifreeze solutions, make sure the glycol percentage is suitable for the type of use envisaged.

NOTE

⇒ *Neglecting the washing will lead to several filter cleaning interventions and at worst cases can cause damages to the exchangers and the other parts.*

Electric Circuit

Verify that the unit is connected to the ground plant.

Check the conductors are tightened as: the vibrations caused by handling and transport might cause these to come loose.

Connect the unit by closing the sectioning device, but leave it on OFF.

Check the voltage and line frequency values which must be within the limits: 400/3/50 +/- 10%

Check and adjust the phase balance as necessary: it must be lower than 2%

NOTE

⇒ Working outside of these limits can cause irreversible damages and voids the warranty.

Compressor crankcase heaters

Connect the oil resistances on the compressor crankcase at least 8 hours before the compressor is to be started:

- at the first unit start-up
 - after each prolonged period of inactivity
- 1 Supply the resistances: isolator switch on 1 / ON.
 - 2 To make sure that heaters are working, check the power input.
 - 3 At start-up the compressor crank-case temperature on the lower side must be higher at least of 10°C than the outside temperature.
 - 4 Do not start the compressor with the crankcase oil below operating temperature.

Voltages

Check that the air and water temperatures are within in the operating limits.

Start-up the unit.

With unit operating in stable conditions, check:

- Voltage
- Total absorption of the unit
- Absorption of the single electric loads

Scroll compressor

The Scroll compressors have only one rotation direction.

In the event it is reversed, the compressor is not immediately damaged, but increases its noise and jeopardises pumping.

After a few minutes, the compressor blocks due to intervention of the thermal protection.

In this case, disconnect power supply and invert 2 phases on the machine power supply.

Avoid the compressor working for a long time with contrary rotation: more than 2-3 of these anomalous start-ups can damage it.

To ensure the rotation direction is correct, measure the condensation and suction pressure.

The pressures must significantly differ: upon start-up, the suction pressure decreases whereas the condensation one, increases.

The phase monitor optional, controlling the phases sequence, can also eventually be installed subsequently.

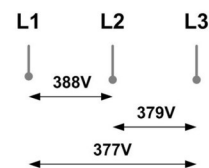

$$1) \frac{388 + 379 + 377}{3} = 381 \text{ (A)}$$

$$2) \text{MAX} - A = 388 - 381 = 7$$

$$3) S = \frac{7}{A} \times 100 = 1,83 \text{ OK}$$

Remote controls

Check that the remote controls (ON-OFF etc) are connected and, if necessary, enabled with the respective parameters as indicated in the “electrical connections” section.

Check that probes and optional components are connected and enabled with the respective parameters (“electrical connections” section and following pages).

Air flow setting

The fan speed setting must be checked by a service centre authorised by Clivet

The real unit flow is according to the aeraulic system features. Before checking, make sure that the system has been completed in all its parts (shunts, dampers, grilles, diffusers etc.).

Check the doors and windows of the serviced room are closed.

Set the flow rate:

par 2252 Mandata_Qset_Is (l/sec)

Delivery air flow management

Constant air flow

Standard mode

The **fan rotation speed** remains constant in all heat load conditions and operation modes.

The ventilation remains active even when the setpoint is fulfilled.

Variable airflow

Option

The **air flow supply** varies depending on the heat load, up to a minimum value compatible with the distribution system and the chosen air diffusion.

The ventilation remains active even when the setpoint is fulfilled.

Eco mode

This function is indicated for the thermal maintenance of the served area in case it is temporarily not used, which can for example occur at night.

To further increase the energy savings in this condition, it is also possible to set less demanding operation setpoints for the unit in respect to the standard mode.

The ECO mode can be activated:

- Manually: P1008 enable setpoint Eco = 1
- Automatically by means supervision system

Constant airflow

Nominal = P2252 (l/s)

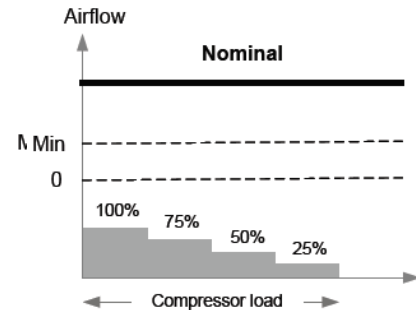

Variable airflow

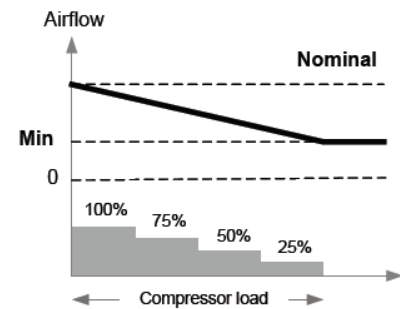

ECO Mode

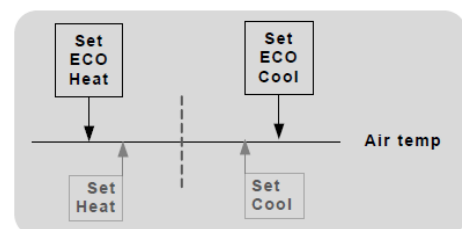

P1002 Setpoint ECO Cool
P1003 Setpoint ECO Heat
P1004 Set UR ECO Cool
P1005 SetUR ECO Heat
P1008 Enable EcoMode

Change mode HEAT - COOL

The mode HEAT - COOL può essere cambiato :

Manually

- from keyboard
- from digital input SA5
- from BMS

Automatically

In function of the room temperature tR

The configuration is done with the parameters indicated in the table

Change mode Heat - Cool		
	Par. 1010	Par. 1006
From keyboard	0	0
From digital input SA5	1	0
From BMS	2	0
Automatic	-	1

Mode AUTO

P1006 = 1

COOL : $tR > \text{set} + (\text{deadzone}/2)$

HEAT : $tR < \text{set} - \text{deadzone}/2$

Par 2313 = deadzone = default 2°C

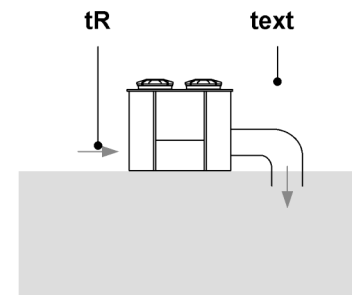
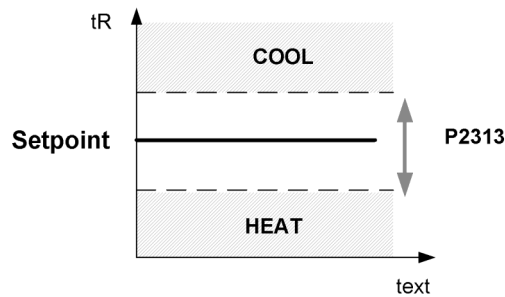

Set-point automatic compensation

The set changes automatically according to the outside temperature.

Even the operating mode changes automatically according to the outside temperature.

The variation is defined by the climatic curve..

The relationship always remains valid:

Setpoint COOL = setpoint HEAT + DeadZone

Par 1006 = 1 Enables automatic mode change

Par 1007 = 1 Enables automatic setpoint

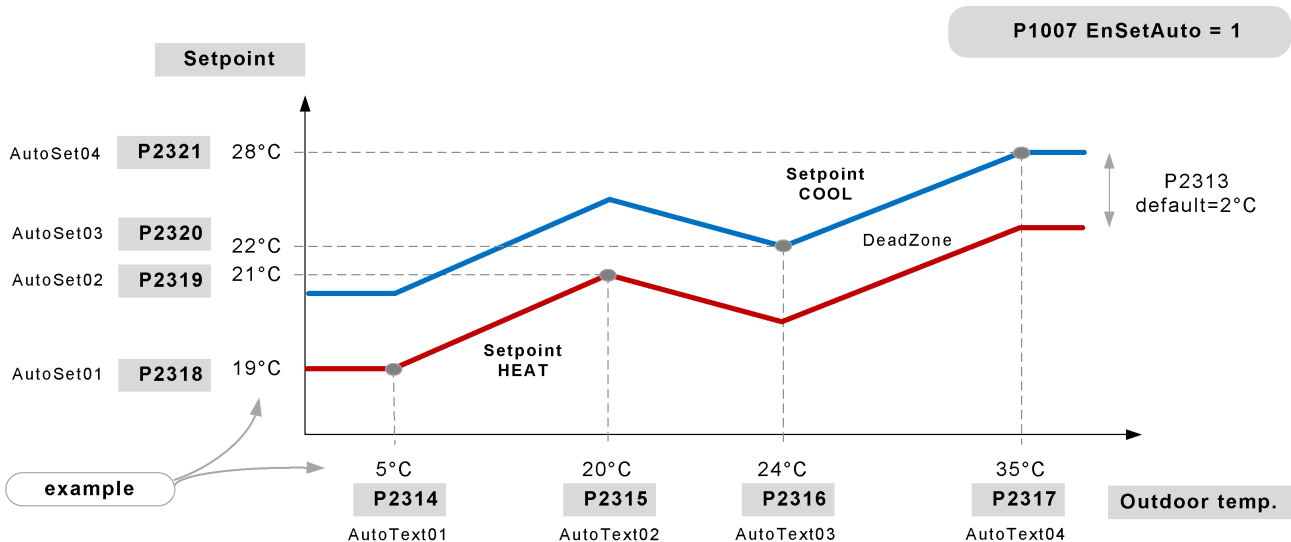

Fire alarm: configuration

The unit is able to manage the signal coming from a fire detection system or fire control unit installed built-in, activating one of the logics illustrated, which can be set by parameter.

Par 3029 TypeFireMode

In the presence of alarm signal, the compressors are Always switched off; moreover, the remote on-off is disabled together with the switch on/off control from keypad.

⇒ *The unit cannot be used as smoke extractor.*

⇒ *Any fire detection devices built-in the unit must be considered as an auxiliary safety system, and, accordingly, must not be a replacement for any fire detection devices in the room.*

Application for low outdoor temperature

Option indicated for very cold climates, where the outside temperature can be between -10 and -30°C.

⇒ *The accessory is also active with unit OFF; the unit must remain powered.*

Start-up report

Identifying the operating objective conditions is useful to control the unit over time.

With unit at steady state, i.e. in stable and close-to-work conditions, identify the following data:

- total voltages and absorptions with unit at full load
- absorptions of the different electric loads (compressors, fans, pumps etc)
- temperatures and flows of the different fluids (water, air) both in input and in output from the unit
- temperature and pressures on the characteristic points of the refrigerating circuit (compressor discharge, liquid, intake)

The measurements must be kept and made available during maintenance interventions.

2014/68/UE PED directive

DIRECTIVE 2014/68/UE PED gives instructions for installers, users and maintenance technicians as well.

Refer to local regulations; briefly and as an example, see the following:

Compulsory verification of the first installation:

- only for units assembled on the installer's building site (for ex. Condensing circuit + direct expansion unit)

Certification of setting in service:

- for all the units

Periodical verifications:

- to be executed with the frequency indicated by the Manufacturer (see the "maintenance inspections" paragraph)

Fire alarm

Unit shutdown

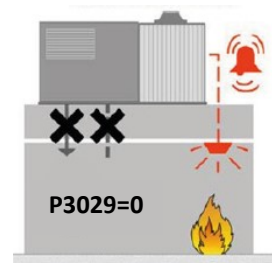

Space in high pressure

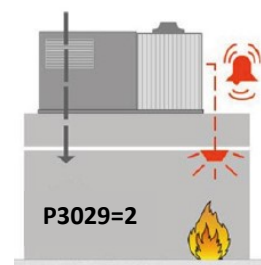

Space in under pressure

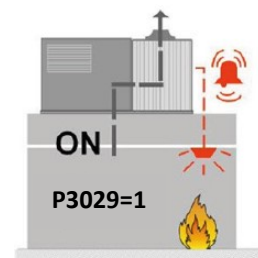

CONTROL



SETPOINT

the display visualizes the **ambient temperature**

1. Press once ▲ or ▼ to display the setpoint (it appears on the display ^{set})
2. press ▲▼ to modify the working setpoint
3. Wait that the ambient temperature appears again on the display (disappears ^{set})

Key function	
	ON-OFF Press 5 seconds to access or switch off the unit.
mode	MODE Change the operating mode : summer, winter, automatic
	CLOCK Date and hour control
OK	OK Confirm, display setpoint, display the outside
	UP-DOWN Shift in the menu, increase-decrease the value
	5 sec Access to the password menu (Code)
mode +	5 sec Access to the alarm menu ; only if the icon is present

Display meaning	
	Operating mode : summer
	Operating mode : winter
	Operating mode : automatic
	supply fan speed
	alarm
	Keyboard locked
	Time band activated
	Time band scheduling
	Active compressor
	Defrosting in progress
	External fan
	electric heaters , hot water coil - option

ON / OFF

	Press for 5 seconds	
OFF		

Button lock / unlock

	Press together for 5 seconds	
OK		
	Symbol appears	

Hour modification - day

- Press the **CLOCK** button for 5 sec.
- By the **▲ ▼** buttons, select the **clock** menu
- Confirm with **OK**
- The hour is flashing : set with the **▲ ▼** buttons
- Confirm with **OK**
- Repeat the procedure for the minutes and week's day
- To go back to the main screen, select the **Esc** menu and confirm with **OK**

Parameters

The setting parameters are protected by password to avoid inadvertent changes that can affect the unit operating.

To access to the parameters

1. press **On/Off + Fan** button for 5 sec.
2. enter password : with the **▲ ▼** button set **Code = 2**
3. Confirm with **OK**
4. Select the **PAr** menu and confirm with **OK**
5. Scroll the list **▲ ▼**
6. Select the parameter with **OK**
7. Modify the value **▲ ▼** and confirm with **OK**
8. To esc, scroll the lost, select **ESC** and confirm with **OK**

On / off scheduling



Press for deactivate or enable the scheduling.



The deactivated scheduling, the symbol  doesn't appear



P02	SetPoint economic on heat mode
P03	SetPoint economic on cool mode
P04	Enable setpoint and the economic functions
P05	Enable automatic setpoint
P06	Set CO2
P200	Enable alarm buzzer : 0 = disabled, 1= enabled

Mode change

Press to set the operating mode:

mode



Cooling





Heating

AUTO

Automatic

Operating in:



Cooling



Time band scheduling

It is possible to set 4 types of scheduling:

- 7 days (from monday to sunday)
- 5 days (from monday to friday)
- 2 days (from saturday to sunday)
- Day by day

Day scheduling



At home



Outside



Return to home

Night scheduling



At home

















Outside the home

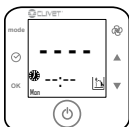

Return to the home

Day by day scheduling

 Press for 5 seconds	
▲ ▼ Press OK	
▲ ▼ Select the scheduling: - Day by day Press OK	
Press OK	
▲ ▼ Set the hour Press OK	
▲ ▼ Set the minutes Press OK	

▲ ▼ Set the temperature Press OK	
▲ Press OK and repeat from point 05	
▲ ▼ As all the programming is finished, select ESC Press OK	
Press OK to program the next day	
▲ ▼ Select the next day Press OK Repeat from point 04	
▲ ▼ To exit from the scheduling select ESC Press OK	
▲ ▼ Select Esc to exit Press OK	

Alarms











Malfunctions are displayed with the ALARM icon.

Before resetting an alarm, identify and remove the cause that generated it.















Repeated reset may cause irreversible damages as a system malfunction.

The alarm can be signalled by the thermostat also by a buzzer.

To disable the buzzer, modify the P200 parameter.

<p>mode</p> <p>The symbol  is displayed</p> <p> Press together for 5 seconds</p>	
<p> </p> <p>Scroll the list</p>	
<p> Select the alarm reset menu</p> <p> Press OK</p>	
<p> Select ESC</p> <p> Press OK</p>	

Stored alarm (installer use only)

<p> </p> <p>Press buttons for 5 sec</p>	
<p> Enter password</p> <p> Confirm with OK</p>	
<p> Select S ALM</p> <p> Confirm with OK</p>	
<p> </p> <p>Scroll alarm list (AL1, AL2...) and display alarm detail</p>	
<p>1° alarm - 1°display</p> <p>AL1 new alarm</p> <p>XX alarm code (STOR)</p>	
<p>1° alarm - 2°display</p> <p>dA1 alarm day 1</p> <p>YY day number after alarm</p>	
<p>1° alarm - 3°display</p> <p>HA1 alarm hour 1</p> <p>hhmm alarm storage hour</p>	

Alarms - 1

alarm	storage	description
A001	1	Clock board not connected
A002	2	Extended memory
A003	3	Input B10 Air quality probe fault / unplugged
A004	4	Input B06 Discharge pressure probe C1 fault / unplugged
A005	5	Input B02 Outdoor temperature probe fault / unplugged
A006	6	Input B01 Supply temperature probe fault / unplugged
A007	7	Input B04-E01 H2O probe fault / unplugged
A008	8	Input B05 Supply differential pressure probe fault / unplugged
A009	9	Input B01-E02 Exhaust air differential pressure probe fault / unplugged
A010	10	Input B03 defrost probe C1 fault / unplugged
A011	11	Input B03-E01 antifreeze probe fault / unplugged
A012	12	Input B11 Discharge pressure probe C1 fault / unplugged
A013	13	Input B04 defrost probe C2 fault / unplugged
A014	14	Input ID10 fire alarm
A015	15	Input ID6 Supply/exhaust fan
A016	16	Input ID07 Thermal overload Circuit 1
A017	17	Input ID08 Thermal overload Circuit 2
A018	18	Input ID03 High pressure Circuit 1
A019	19	Input ID04 High pressure Circuit 2
A020	20	Input ID03-E01 High temperature electric heaters / gas module
A021	21	Input ID05 Dirty filters
A022	22	Input ID09 Phase monitor
A023	23	Room temperature probe
A024	24	Outdoor temperature probe
A025	25	Supply temperature probe
A026	26	UR room probe
A027	27	UR outdoor probe
A028	28	Serial probe 1 UR outdoor fault / unplugged
A029	29	Serial probe 1 Outdoor temperature
A030	30	Serial probe 1 Outdoor temperature fault / unplugged
A031	31	Analogic input low pressure 1
A032	32	Analogic input low pressure 2
A033	33	Input ID05 Dirty filters
A034	34	Unit configurazione error
A035	35	Circuit 1 not available for alarm
A036	36	Circuit 2 not available for alarm
A037	37	Analogic low pressure circuit 1

Alarms - 2

alarm	storage	description
A038	38	Analogic low pressure circuit 2
A039	39	Antifreeze
A040	40	Antifreeze prealarm outdoor temperature
A041	41	Prealarm HP1 Circuit 1
A042	42	Prealarm HP1 Circuit 2
A043	43	Prealarm HP2 Circuit 1
A044	44	Prealarm HP2 Circuit 2
A045	45	Prealarm LP1 Circuit 1
A046	46	Prealarm LP1 Circuit 2
A047	47	Prealarm HP2 Circuit 1
A048	48	Prealarm HP2 Circuit 2
A049	49	Prealarm LP1 Circuit 1
A050	50	Prealarm LP1 Circuit 2
A051	51	Supply high temperature
A052	52	Supply low temperature - heat mode
A053	53	Defrost circuit 1 not available - Circuit 2 in alarm
A054	54	Defrost circuit 2 not available - Circuit 1 in alarm
A055	55	Disabling auto mode
A056	56	Forced defrost circuit 1 for low suction pressure
A057	57	Forced defrost circuit 2 for low suction pressure
A058	58	Max defrost NR circuit 1 ended for supply temp.
A059	59	Max defrost NR circuit 2 ended for supply temp.
A060	60	Supply air flow outside limits
A061	61	Exhaust air flow outside limits
A062	62	CPY:01
A063	63	Probe S1: suction pressure circuit 1
A064	64	Probe S2: suction temperature circuit 1
A065	65	Probe S3: suction pressure circuit 2
A066	66	Probe S4: suction temperature circuit 2
A067	67	Low superheating (LowSH) Valve A
A068	68	Low superheating (LowSH) Valve B
A069	69	Low suction temperature (LOP) Valve A
A070	70	Low suction temperature (LOP) Valve B
A071	71	High suction temperature (MOP) Valve A
A072	72	High suction temperature (MOP) Valve B
A073	73	High condensing temperature (HiTCond)
A074	74	Low suction temperature Valve A

Alarms - 3

alarm	storage	description
A075	75	Low suction temperature Valve B
A076	76	Autotune Valve A
A077	77	Autotune Valve B
A078	78	Serial probe n°1 Probe Offline
A079	79	Serial probe n°1 UR fault
A080	80	Serial probe n°1 temperature fault
A081	81	pCOe 1 offline
A082	82	pCOe 1 probe analogic input channel 1 fault / unplugged
A083	83	pCOe 1 probe analogic input channel 2 fault / unplugged
A084	84	pCOe 1 probe analogic input channel 3 fault / unplugged
A085	85	pCOe 1 probe analogic input channel 4 fault / unplugged
A086	86	pCOe 1 I/O mismatch (no confirmation from pCO for 10s)
A087	87	pCOe 2 offline
A088	88	pCOe 2 probe analogic input channel 1 fault / unplugged
A089	89	pCOe 2 probe analogic input channel 2 fault / unplugged
A090	90	pCOe 2 probe analogic input channel 3 fault / unplugged
A091	91	pCOe 2 probe analogic input channel 4 fault / unplugged
A092	92	pCOe 2 mismatch (no confirmation from pCO for 10s)
A093	93	Gas module
A094	94	Electronic filters
A095	95	Serial probe 2 room UR fault / unplugged
A096	96	Serial probe 2 room air
A097	97	Serial probe 2 room temperature fault / unplugged

Stata

To access to the main stata

- 1 press **OK**
- 2 scroll the list with **OK**
 - Setpoint room temperature
 - UR *
 - Setpoint UR
 - Outdoor temperature *

* if enabled dehumidification function and Cool mode, humidification function and Heat mode

To access to the stata menu :

- 1 Press the On/Off + Fan button for 5 sec.
- 2 Enter the password: with **▲ ▼** buttons, set **Code = 1**
- 3 Confirm with **OK**
- 4 The **Sta** menu appears, confirm with **OK**
- 5 Scroll the list of stata with **▲ ▼** buttons
- 6 To esc scroll the list, select **ESC** and confirm with **OK**

Status	Description	UM
S001	Temperature Setpoint setted from thermostat	°C
S002	UR Setpoint setted from thermostat	%Ur
S100	Room temperature (room thermostat)	°C
S101	Room UR	%Ur
S102	Outdoor temperature (serial probe)	°C
S103	Outdoor UR (serial probe)	%Ur
S104	Digital inputs 1 .. 4	---
	1000 - ON – OFF remoto	
	0100 - HEAT – COOL remote (aperto = HEAT)	
	0010 - HP circuit 1	
	0001 - HP circuit 2	
S105	Digital inputs 5 .. 8	---
	1000 - Dirty filters	
	0100 - Fan (thermal overload, doors open)	
	0010 - Thermal overload circuit 1 (compressor, fan)	
	0001 - Thermal overload circuit 2 (compressor, fan)	
S106	Digital inputs 9 .. 10	---
	1000 - Phase monitor	
	0100 - Fire alarm	
S107	Digital outputs 1 .. 4	---
	1000 - Supply fan	
	0100 - Source fan circuit 1	
	0010 - 4-way valve circuit 1	
	0001 - Compressor 1 circuit 1	

Stata - 2

Status	Description	UM
S108	Digital output 5 .. 8	---
	1000 - Compressor 1 circuit 2	
	0100 - 4-vay valve circuit 2	
	0010 - Valve compressor digital C1	
	0001 - Not used	
S109	digital output 9 .. 12	---
	1000 - Cumulative alarms	
	0100 - source fan circuit 2	
	0010 - Postheating hot gas	
	0001 - external humidifier command	
S110	Supply temperature (analogic input 1)	°C
S111	Outdoor temperature (analogic input 2)	°C
S112	Outdoor coil temperature circuit 1 (analogic input 3)	°C
S113	Outdoor coil temperature circuit 2 (analogic input 4)	°C
S114	differential pressure supply fan (analogic input 5)	Pa
S115	Discharge pressure circuit 1 (analogic input 6)	bar
S116	Suction pressure circuit 1 (analogic input 7)	bar
S117	Suction temperature circuit 1 (analogic input 8)	°C
S118	Suction temperature circuit 2 (analogic input 9)	bar
S119	Air quality probe (analogic input 10)	ppm
S120	Discharge pressure circuit 2 (analogic input 11)	bar
S121	Suction pressure circuit 2 (analogic input 12)	bar
S122	Supply fan (analogic output 1)	V
S123	Source fan circuit 1 (analogic output 2)	V
S124	Exhaust air fan (analogic output 3)	V
S125	Source fan circuit 2 (analogic output 4)	V
S126	Digital input 1 .. 4 expansion 1	---
	1000 - gas module	---
	0100 - electronic filters alarm	---
	0010 - high temperature aux elements alarm	---
	0001 - Not used	---
S127	Digital output 1 .. 4 expansion 1	---
	1000 - water request from customer / Command gas module 1° step	---
	0100 - Signal status exhaust air fan	---
	0010 - Command electric heaters / Command gas module 1° step	---
	0001 - Not used	---

Stata - 3

Status	Description	UM
S128	differential pressure exhaust air (analogic input 1 expansion 1)	Pa
S129	not used (analogic input 2 expansion 1)	
S130	antifreeze temperature auxiliary elements 7 hidronic recovery (analogic input 3 expansion 1)	°C
S131	not used (analogic input 4 expansion 1)	
S132	modulating signal hot water coil / gas module (analogic output 1 expansion 1)	V
S133	digital input 1..4 expansion 2	---
	1000 - not used	
	0100 - not used	
	0010 - not used	
	0001 - not used	
S134	digital output 1 .. 4 expansion 2	---
	1000 - Compressor 2 circuit 1	
	0100 - Compressor 2 circuit 2	
	0010 - not used	
	0001 - not used	
S135	not used (analogic input 1 expansion 2)	---
S136	not used (analogic input 2 expansion 2)	---
S137	not used (analogic input 3 expansion 2)	---
S138	not used (analogic input 4 expansion 2)	---
S139	not used (analogic output expansion 2)	V
S140	Room temperature (serial probe)	°C
S141	Room UR (serial probe)	%Ur
S200	Unit status	---
S201	Unit mode	---
S202	Supply air flow	m³/h/10
S203	Exhaust air flow	m³/h/10
S204	Supply air flow	l/s
S205	Exhaust air flow	l/s
S206	Capacity request	%
S207	Capacity request (from outdoor temperature)	%
S208	Capacity request (from supply temperature)	%
S209	Capacity delivered from Free Cooling/Heating	%

Stata - 4

Status	Description	UM
S210	Capacity request to compressors	%
S211	Capacity requested to the aux. element	%
S212	Capacity requested for dehumidification	%
S300	Functioning hours compressor 1 circuit 1	h
S301	Starts compressor 1 circuit 1	---
S302	Functioning hours compressor 2 circuit 1	h
S303	Starts compressor 2 circuit 1	---
S304	Functioning hours compressor 1 circuit 2	h
S305	Starts compressor 1 circuit 2	---
S306	Functioning hours compressor 2 circuit 2	h
S307	Starts compressor 2 circuit 2	---
S995	Software type = 2	
S996	Software version	
S997	Day software release	
S998	Month software release	
S999	Year software release	

MAINTENANCE

Safety

Operate in compliance with safety regulations in force.

Use single protection devices: gloves, glasses etc.

General

Maintenance must be performed by authorized centres or by qualified personnel

The maintenance allows to:

- maintaining the unit efficient
- reduce the deterioration speed all the equipment is subject to over time
- collect information and data to understand the efficiency state of the unit and prevent possible faults

WARNING

⇒ *Before checking, please verify the following:*

⇒ *the electrical power supply line should be isolated at the beginning*

⇒ *the line isolator device is open, locked and equipped with the suitable warning sign*

⇒ *make sure no tension is present*

⇒ *After switching the power off, wait at least 5 minutes before accessing to the electrical panel or any other electrical component.*

⇒ *Before accessing check with a multimeter that there are no residual stresses.*

Frequency of interventions

Perform an inspection every 6 months.

However, frequency depends on the type of use.

Pan inspections at close intervals in the event of:

- frequent use (continuous or very intermittent use, near the operating limits, etc)
- critical use (service necessary)

Unit booklet

It's advisable to create a unit booklet to take notes of the unit interventions.

In this way it will be easier to adequately note the various interventions and aid any troubleshooting.

Report on the booklet:

- date
- intervention description

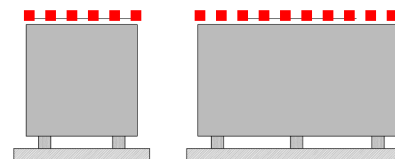

Recommended periodic checks sheet

	intervention frequency (months)	1	6	12
1	presence of corrosions			X
2	panel fixing			X
3	fan fixing		X	
4	coil cleaning		X	
5	bowl cleaning + sanitisation		X	
6	outflow test		X	
7	air filters cleaning / inspection	X		
8	air flow rate measurement			X
9	channelling: anti-vibration devices and fastenings check			X
10	check of the fixing and the insulation of the power lead			X
11	check of the earthing cable			X
12	electric panel cleaning			X
13	power remote controls status			X
14	clamp closure, cable isolation integrity			X
15	voltage and phase unbalancing (no load and on-load)		X	
16	absorptions of the single electrical loads		X	
17	compressor casing heaters test		X	
18	checking for leaks *			*
19	cooling circuit work parameter detection		X	
20	safety valve *			*
21	protective device test: pressure switches, thermostats, flow switches etc..			X
22	control system test: setpoint, climatic compensations, capacity stepping, air flow-rate variations			X
23	control device test: alarm signalling, thermometers, probes, pressure gauges etc			X
24	electrical heaters check - option			X
25	water coil check - option			X

NOTE

⇒ **Refer to the local regulations. Companies and technicians performing installation, maintenance/repair, leak control and recovery operations must be CERTIFIED as set out by the local regulations.*

Wall mounted electronic room control

In the maintenance operations the keypad can be detached from the fixing support and directly connected to the unit electrical panel.

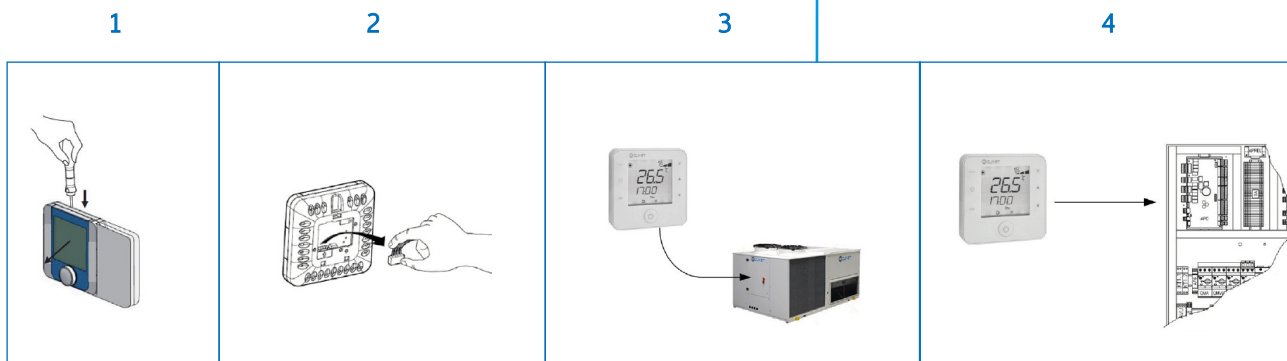

Structure

Check the condition of the parts making up the structure

Paint so as to eliminate or reduce oxidation at the points in the unit where this problem may occur

Check that the panelling is fastened correctly

Poor fastening may give rise to malfunctions and abnormal noise and vibration

Outdoor air coil

Contact with the exchanger fins can cause cuts: wear protective gloves to perform the above described operations.

It is extremely important that the battery gives the maximum thermal exchange; therefore, its surface must be cleaned from dust and deposits.

Remove all impurities from the surface.

Using an air pressure gun, clean the aluminum surface of the battery; be careful to direct the air in the opposite direction of the fan air movement.

Hold the gun parallel to the fins to avoid damages.

As an alternative, vacuum cleaner can be used to suck impurities from the air input side.

Verify that the aluminum fins are not bent or damaged, in the event of damages contact the authorized assistance center and get the fins straightened in order to restore the initial condition for an optimal air flow.

Indoor air coil

Contact with the exchanger fins can cause cuts: wear protective gloves to perform the above described operations.

The finned surfaces of the cooling coils and, in particular, the condense collection bowls constitute places where microorganisms and moulds greatly flourish.

It is very important to foresee periodical cleaning with suitable detergents and, eventually, disinfect with sanitising products.

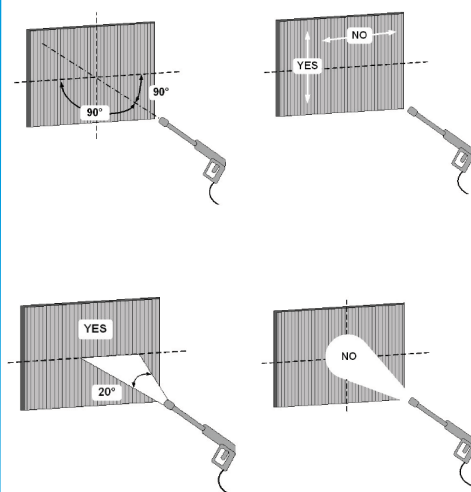

Condensation collection basin

Dirt or scale can give rise to clogging.

Also, microorganisms and mould can flourish in the bowl.

It is very important to foresee periodical cleaning with suitable detergents and, eventually, disinfect with sanitising products.

Once cleaning is completed, pour water inside the bowl to check the regular outflow.

Compressor supply line shut-off valve (A)

Only if present.

Do not remove the seal

Remove only if authorized by the manufacturer.

Please contact the maker for informations.

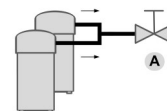

Compressor casing heater

Check:

- closure
- Operation

G4 (ISO 16890 Coarse 60%) Folded air filters

It is very important for the air treatment coil to offer maximum thermal exchange: the unit must always work with clean and installed filters.

Cleaning and replacement of filters are very important from an hygienic-sanitary point of view.

Operation with clogged filters leads to a reduction in the air flow rate with malfunctionings and block, up to possible breaks in the unit.

The frequency with which the filters must be checked depends on the quality of the air, the unit operation hours, the dustiness and crowding of rooms.

Frequency can indicatively vary from WEEKLY to MONTHLY.

It is advised to start with frequent checks, subsequently adjusting frequency to degree of detected dirt.

- 1 Remove the closing panels
- 2 Delicately remove the filter avoiding dirtying the area below
- 3 Wash the filtering jacket in warm water with common detergent
- 4 Accurately rinse in running water avoiding spilling in the room
- 5 Dry the filter
- 6 Insert it back in its seat
- 7 Remount the closing panels

Old filters, washing wastewater and residues must be disposed of according to the current standards.



F7 (ISO 16890 ePM1 55%) / F9 (ISO 16890 ePM1 80%) filters

Option

The filters are not renewable, once dirty they must be replaced.

- 1 Open the access panel
- 2 Delicately remove the filter avoiding dirtying the area below
- 3 Insert the new filters, with the pockets vertically
- 4 Close the panel
- 5 Dispose of the old filters sending them to specialised recycling or collection centres (keep to the standards in force)

FES (ISO 16890 ePM1 90%) Electronic filters

Option

The electronic adjustment is integrated in the filter; maintenance can be carried out without removing it.

Materials necessary for maintenance

- 1 Acid detergent B01212 (code CLIVET C6460316)
- 2 Plastic or steel tank (750x750x310 mm) with settling bottom
- 3 Protective gloves and goggles
- 4 Graduated jug
- 5 Pump for manual or pneumatic spraying

Do not use aluminum tanks or galvanized

Foresee a stainless steel frame that keeps the filters lifted from the tank base to have a settling bottom for the muds.

Remove the pre-filter by lifting it of about 1 cm and remove it as shown in figure.

- 1 Position the filter to be washed on a support to facilitate work.
- 2 Prepare a tank with a solution of B01212 detergent and water at 1÷20.
- 3 Immerse the filter in this solution.
- 4 Ensure the solution covers the entire filter.
- 5 A slight chemical reaction is noticed within 2÷3 minutes with the development of foam. Wait 3 or 4 minutes.
- 6 Rinse the filter with a jet of water or using a low-pressure water jet machine.
- 7 Leave the electrostatic cells to dry in a hot room or directly in the sun for a few hours. Keep the cells lifted from the ground using two metal or wooden laths.
- 8 Check the ionisation wires before remounting the filter.

The cleaner can be used to clean about 20 filters.

Can be recovered and placed in plastic containers closed; the air oxidizes the cleaner and reduces its effectiveness.

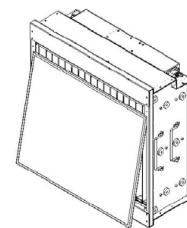
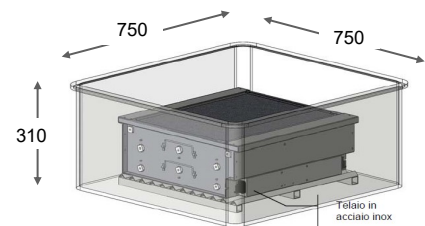

Ionisation wires

The impurities can determine oxidation or scaling on the wires, which can be removed using a cloth soaked in alcohol or an abrasive scourer with very fine grain.

Due to the high voltage powering them, the ionisation wires are subject to wear.

To foresee a yearly replacement OF ALL WIRES avoids unexpected breaks.

In case of break:

- 1 remove all wire pieces present in the cell and remove the springs stretching the wire
- 2 hook the spring to the wire eyelet
- 3 grip the ionisation wire with curved beaks pliers
- 4 hook the top of the spring with the open eyelet to the wire stretcher rod of the electrostatic cell
- 5 keeping the ionisation wire stretched, with the other hand hook it to the other wire stretching rod, always by means of the curved beaks pliers

Immersed electrode humidifier

Option

Do not use solvents or detergents to clean the plastic components.

For descaling use a vinegar or acetic acid solution at 20%, subsequently rinsing with water.

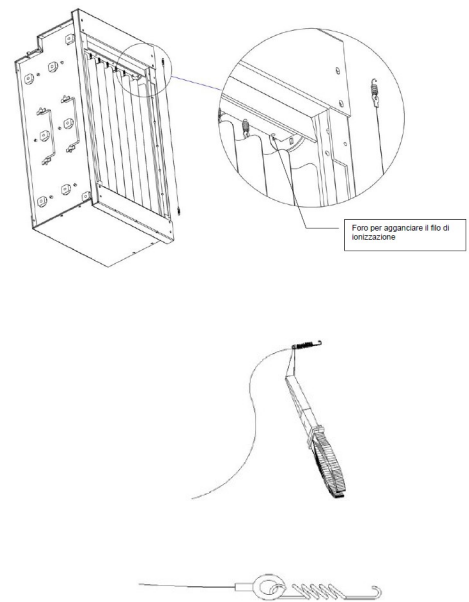

Periodical checks

15 days	Cylinder: not over 300 hours of work checking operation, general state, no leaks
90 days	Cylinder: not over 1000 hours of work checking operation, general state, no leaks, any replacement
1 year	Cylinder: not over 2500 hours of work (disposable cylinders) Load solenoid valve replacement: disconnect electric power supply, dismantle valve, clean the filter. Drain solenoid valve: disconnect electric power supply, remove reel and dismantle valve body and any impurity and rinse. The power supply bowl, piping: check they are free and without impurities.
5 years	Cylinder: not over 10000 hours of work (inspectional cylinders) replacement

Humidifier cylinder drainage

Cylinder must be drained in these situations:

- cleaning of the cylinder
- emptying of the cylinder to avoid ice forming
- replacement of the cylinder

The manual drainage is carried out by means of selector SA7: see ELECTRIC CONNECTIONS chapter.

Replacement of the cylinder

To remove the cylinder:

- completely drain the water
- interrupt power supply voltage of humidifier by means of the unit isolator
- remove the vapour pipe from the cylinder
- disconnect the electric connections of the electrodes and remove the pins from the high level electrodes
- loosen the ring nut to remove the pipe unions and the filter (when filter is outside the cylinder)
- lift the cylinder to remove it

Before mounting it:

- the filter body does not require replacing, wash it with water and remount it on the new cylinder, using the new gasket provided with the latter
- check the seal gasket between the cylinder and the drain unit
- remount the cylinder repeating the operations in reverse order

Electric heaters

Option

Check:

- cleaning state
- fastening
- presence of corrosion

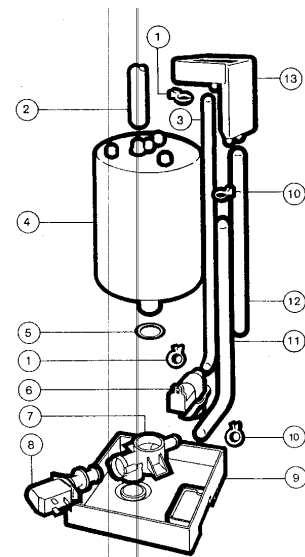

- 1 pipe fixing spring
- 2 vapour pipe
- 3 load pipe
- 4 vapour cylinder
- 5 seal O-rings
- 6 load valve
- 7 valves support
- 8 drain valve
- 9 bottom tank
- 10 pipe fixing spring
- 11 load pipe
- 12 too full pipe
- 13 fill tank

DECOMMISSIONING

Disconnection

WARNING

⇒ Before performing any operation, read the warnings found in the Maintenance chapter.

Avoid leak or spills into the environment.

Before disconnecting the unit, the following must be recovered, if present:

- refrigerant gas
- Anti-freeze solutions in the hydraulic circuit

Awaiting decommissioning and disposal, the unit can also be stored outdoors, as bad weather and rapid changes in temperature do not harm the environment provided that the electric, cooling and hydraulic circuits of the unit are intact and closed.

WEEE INFORMATION

The manufacturer is registered on the EEE National Register, in compliance with implementation of Directive 2012/19/EU and relevant national regulations on waste electrical and electronic equipment.

This Directive requires electrical and electronic equipment to be disposed of properly.

Equipment bearing the crossed-out wheelee bin mark must be disposed of separately at the end of its life cycle to prevent damage to human health and to the environment.

Electrical and electronic equipment must be disposed of together with all of its parts.

To dispose of “household” electrical and electronic equipment, the manufacturer recommends you contact an authorised dealer or an authorised ecological area.

“Professional” electrical and electronic equipment must be disposed of by authorised personnel through established waste disposal authorities around the country.

In this regard, here is the definition of household WEEE and professional WEEE:

WEEE from private households: WEEE originating from private households and WEEE which comes from commercial, industrial, institutional and other sources which, because of its nature and quantity, is similar to that from private households. Subject to the nature and quantity, where the waste from EEE was likely to have been by both a private household and users of other than private households, it will be classed as private household WEEE;

Professional WEEE: all WEEE which comes from users other than private households.

This equipment may contain:

refrigerant gas, the entire contents of which must be recovered in suitable containers by specialised personnel with the necessary qualifications;

- lubrication oil contained in compressors and in the cooling circuit to be collected;
- mixtures with antifreeze in the water circuit, the contents of which are to be collected;
- mechanical and electrical parts to be separated and disposed of as authorised.

When machine components to be replaced for maintenance purposes are removed or when the entire unit reaches the end of its life and needs to be removed from the installation, waste should be separated by its nature and disposed of by authorised personnel at existing collection centres.



RESIDUAL RISKS

General

In this section the most common situations are indicated, as these cannot be controlled by the manufacturer and could be a source of risk situations for people or things.

Danger zone

This is an area in which only an authorised operator may work.

The danger zone is the area inside the unit which is accessible only with the deliberate removal of protections or parts thereof.

Handling

The handling operations, if implemented without all of the protection necessary and without due caution, may cause the drop or the tipping of the unit with the consequent damage, even serious, to persons, things or the unit itself.

Handle the unit following the instructions provided in the present manual re-garding the packaging and in compliance with the local regulations in force.

Should the refrigerant leak please refer to the refrigerant "Safety sheet".

Installation

The incorrect installation of the unit could cause water leaks, condensate accumulation, leaking of the refrigerant, electric shock, poor operation or damage to the unit itself.

Check that the installation has been implemented by qualified technical personnel only and that the instructions contained in the present manual and the local regulations in force have been adhered to.

The installation of the unit in a place where even infrequent leaks of inflammable gas and the accumulation of this gas in the area surrounding the area occur could cause explosions or fires.

Carefully check the positioning of the unit.

The installation of the unit in a place unsuited to support its weight and/or guarantee adequate anchorage may result in consequent damage to things, people or the unit itself.

Carefully check the positioning and the anchoring of the unit.

Easy access to the unit by children, unauthorised persons or animals may be the source of accidents, some serious.

Install the unit in areas which are only accessible to authorised person and/or provide protection against intrusion into the danger zone.

General risks

Smell of burning, smoke or other signals of serious anomalies may indicate a situation which could cause damage to people, things or the unit itself.

Electrically isolate the unit (yellow-red isolator).

Contact the authorised service centre to identify and resolve the problem at the source of the anomaly.

Accidental contact with exchange batteries, compressors, air delivery tubes or other components may cause injuries and/or burns.

Always wear suitable clothing including protective gloves to work inside the danger zone.

Maintenance and repair operations carried out by non-qualified personnel may cause damage to persons, things or the unit itself.

Always contact the qualified assistance centre.

Failing to close the unit panels or failure to check the correct tightening of all of the panelling fixing screws may cause damage to persons, things or the unit itself.

Periodically check that all of the panels are correctly closed and fixed.

If there is a fire the temperature of the refrigerant could reach values that increase the pressure to beyond the safety valve with the consequent possible projection of the refrigerant itself or explosion of the circuit parts that remain isolated by the closure of the tap.

Do not remain in the vicinity of the safety valve and never leave the refrigerating system taps closed.

Electric parts

An incomplete attachment line to the electric network or with incorrectly sized cables and/or unsuitable protective devices can cause electric shocks, intoxication, damage to the unit or fires.

Carry out all of the work on the electric system referring to the electric layout and the present manual ensuring the use of a system thereto dedicated.

An incorrect fixing of the electric components cover may lead to the entry of dust, water etc inside and may consequently electric shocks, damage to the unit or fires.

Always fix the unit cover properly.

When the metallic mass of the unit is under voltage and is not correctly connected to the earthing system it may be as source of electric shock and electrocution.

Always pay particular attention to the implementation of the earthing system connections.

Contact with parts under voltage accessible inside the unit after the removal of the guards can cause electric shocks, burns and electrocution.

Open and padlock the general isolator prior to removing the guards and signal work in progress with the appropriate sign.

Contact with parts that could be under voltage due to the start up of the unit may cause electric shocks, burns and electrocution.

When voltage is necessary for the circuit open the isolator on the attachment line of the unit itself, padlock it and display the appropriate warning sign.

Moving parts

Contact with the transmissions or with the fan aspiration can cause injuries.

Prior to entering the inside of the unit open the isolator situated on the connection line of the unit itself, padlock and display the appropriate warning sign.

Contact with the fans can cause injury.

Prior to removing the protective grill or the fans, open the isolator on the attachment line of the unit itself, padlock it and display the appropriate warning sign.

Refrigerant

The intervention of the safety valve and the consequent expulsion of the gas refrigerant may cause injuries and intoxication.

Always wear suitable clothing including protective gloves and eyeglasses for operations inside the danger zone.

Should the refrigerant leak please refer to the refrigerant "Safety sheet".

Contact between open flames or heat sources with the refrigerant or the heating of the gas circuit under pressure (e.g. during welding operations) may cause explosions or fires.

Do not place any heat source inside the danger zone.

The maintenance or repair interventions which include welding must be carried out with the system off.

Hydraulic parts

Defects in tubing, the attachments or the removal parts may cause a leak or water projection with the consequent damages to people, things or shortcircuit the unit.

Configuration: fresh air supply only (CBFFA)

SIZE			12.1	16.2	20.4	22.4	24.4
COOLING							
Cooling capacity	1	kW	33.1	49.5	76.1	83.4	90.4
Sensible capacity	1	kW	18.8	27.8	38.3	43.3	48.0
Compressor power input	1	kW	9.2	12.9	20.0	21.7	23.3
EER	1	-	3.60	3.84	3.81	3.84	3.88
HEATING							
Heating capacity	2	kW	39.6	50.0	73.2	81.4	89.5
Compressor power input	2	kW	9.9	11.9	17.2	18.2	20.7
COP	2		4.00	4.20	4.26	4.47	4.32
COMPRESSOR							
Type of compressors	3		Scroll	Scroll	Scroll	Scroll	Scroll
No. of compressors		Nr	2	2	4	4	4
Std Capacity control steps		Nr	2	3	4	4	4
Refrigerant Charge(C1)	4	kg	8	10,5	8	8	13
Refrigerante Charge (C2)	4	kg	8	12,5	8,5	14	13
Refrigeration circuits		Nr	2	2	2	2	2
AIR HANDLING SECTION FANS (SUPPLY)							
Type of supply fan	5		RAD	RAD	RAD	RAD	RAD
Number of supply fans		Nr	1	1	1	1	1
Fan diameter		mm	400	400	560	560	560
Type of motor	6		EC	EC	EC	EC	EC
Supply airflow		m ³ /h	3400	4500	6000	7000	8000
Supply airflow		l/s	944	1250	1667	1944	2222
Installed unit power		kW	1.3	1.3	2.9	2.9	2.9
Max. static pressure supply fan	7	Pa	675	470	775	730	650
HIGH STATIC PRESSURE AIR HANDLING SECTION FANS (OPTIONAL)							
Type of supply fan	5		RAD	RAD	RAD	RAD	RAD
Number of supply fans		Nr	1	1	1	1	1
Fan diameter		mm	500	500	500	500	500
Type of motor	8		EC	EC	EC	EC	EC
Supply airflow		l/s	944	1250	1667	1944	2222
Supply airflow		m ³ /h	3400	4500	6000	7000	8000
Installed unit power		kW	2,6	2,6	5,5	5,5	5,5
Max. static pressure supply fan		Pa	890	810	1260	1260	1260
FANS (EXHAUST) (ONLY WITH CCFFA CONFIGURATION)							
Type of exhaust fan	5,8		RAD	RAD	RAD	RAD	RAD
Number of exhaust fans	8	Nr	1	1	1	1	1
Fan diameter	8	mm	400	400	500	500	500
Type of motor	8		EC	EC	EC	EC	EC
Exhaust airflow	9	l/s	0-944	0-1250	0-1667	0-1944	0-2222
Installed unit power	8	kW	1.3	1.3	2.6	2.6	2.6
Max. exhaust static pressure	8	Pa	550	400	670	560	430

1. Fresh air temperature: 35°C D.B./ 24°C W.B. EER referred only to compressors
2. Fresh air temperature: 7°C D.B./ 6°C W.B. COP referred only to compressors
3. SCROLL = Scroll compressor
4. Indicative values for standard units with possible variation +/- 10%. The actual data are shown on the unit's serial label

5. RAD = Radial fan
6. EC = Electronic switching motor
7. Available nett pressure to overcome the supply
8. CCFFA - Configuration for fresh air supply with extraction and exhaust
9. Range of variability of the exhaust air flow (only for CCFFA configuration)

General technical data

EXTERNAL SECTION FANS

Type of fans	9	AX	AX	AX	AX	AX
Number of fans	Nr	2	2	2	2	2
Fan diameter	mm	630	630	800	800	800
Standard airflow	l/s	6940	6940	11670	11670	11670
Installed unit power	kW	1.05	1.05	1.5	1.5	1.5

CONNECTIONS

Condensate drain	mm	20	20	20	20	20
------------------	----	----	----	----	----	----

POWER SUPPLY

Standard power supply	V	400/3~/50	400/3~/50	400/3~/50	400/3~/50	400/3~/50
-----------------------	---	-----------	-----------	-----------	-----------	-----------

8. Range of variability of the exhaust air flow (only for CCFFA configuration)

10. AX = Axial fan

Sound levels

SIZE	Sound power level (dB)								Sound pressure level dB(A)	Sound Power Level dB(A)
	Octave band (Hz)									
	63	125	250	500	1000	2000	4000	8000		
12.2	76	79	76	77	77	76	74	73	65	83
16.2	76	79	78	80	80	78	75	79	66	85
20.4	92	82	80	81	79	77	74	75	67	84
22.4	92	83	81	82	80	78	75	73	68	85
24.4	92	84	82	84	82	79	76	76	69	87

The sound levels are referred to unit operating at full load in nominal conditions. The sound pressure level is referred at a distance of 1 m. from the ducted unit surface operating in free field conditions. External static pressure 50 Pa. (standard UNI EN ISO 9614-2)

Please note that when the unit is installed in conditions different from nominal test conditions (e.g. near walls or obstacles in general), the sound levels may undergo substantial variations.

Operating range (Cooling)

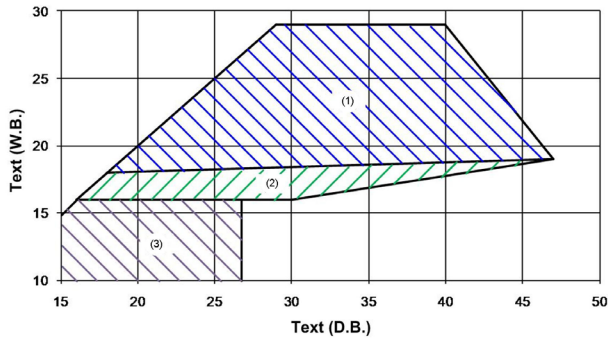

The limits are indicative and take into consideration:

- general and non specific sizes
- standard airflow
- operation at full load
- unit correctly installed and serviced

Text (D.B.) = Ambient air temperature / handling coil inlet dry bulb measured temperature (D.B.=DRY BULB)

Text (W.B.) = Ambient air temperature / handling coil inlet WARNING! WET BULB TEMPERATURE (W.B. = WET BULB)

1. Operation range at full load
2. Operating field at partial load (one active compressor for each refrigerant circuit)
3. FREE-COOLING range operating



WET BULB TEMPERATURE - EXAMPLE

28°C W.B.	40°C D.B. / 4% R.H.
	35°C D.B. / 59% R.H.
	30°C D.B. / 86% R.H.

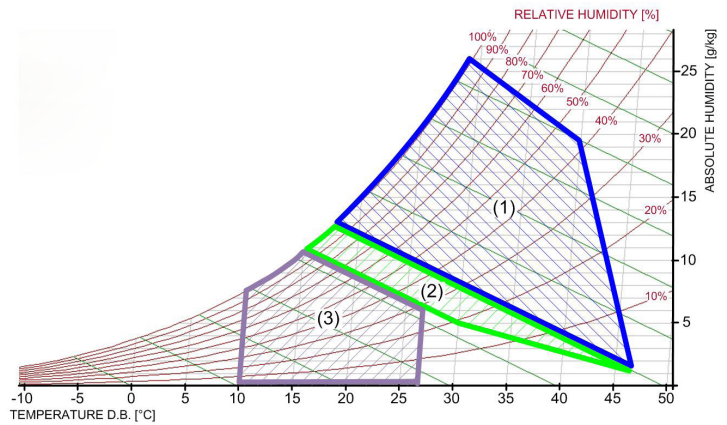

Operating range (Heating)

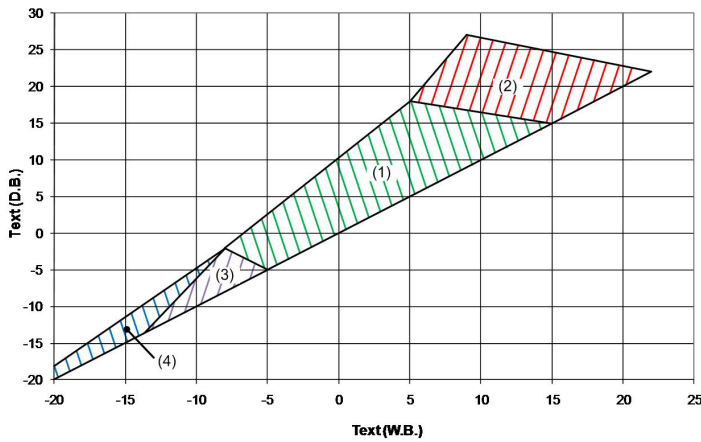

The limits are indicative and take into consideration:

- general and non specific sizes
- standard airflow
- operation at full load
- unit correctly installed and serviced

Text (D.B.) = Ambient air temperature / handling coil inlet dry bulb measured temperature (D.B.=DRY BULB)

TEXT (W.B.) = Fresh air temperature/inlet of treatment coil WARNING! WET BULB TEMPERATURE (W.B. = WET BULB)

1. Operation range at full load
2. Operating field at partial load (one active compressor for each refrigerant circuit)
3. Operating field of the unit with external low temperature equipment and pre-heating resistances or hot water coil options.
4. Operating field of the unit with external low temperature equipment and hot water coil or gas heating module options

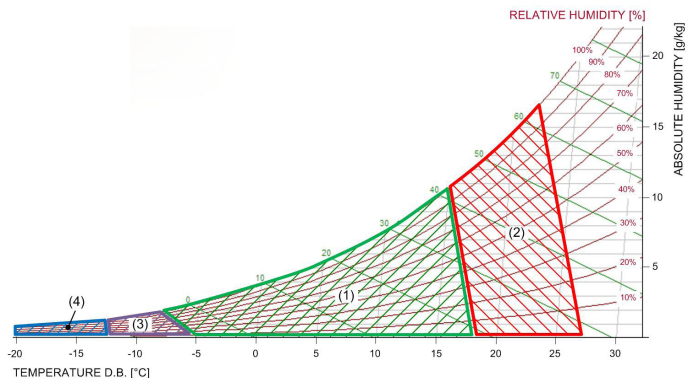

Functional spaces

When placing the unit, it is necessary to comply with the functional spaces indicated in the dimensions. Compliance with functional spaces is essential to:

- ensure proper operation of the unit;
- allow maintenance technicians easy access to the equipment compartments;
- protect authorized operators and exposed persons.

If several units are placed near one another, the functional spaces between units must be doubled.

Size 12.2 - 16.2 - CBFFA configuration

DAA712.2_16.2_CBFFA_02
Date 13/02/2018

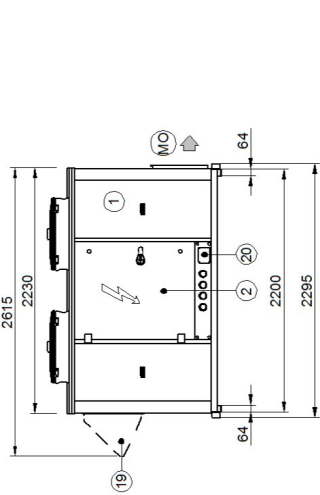
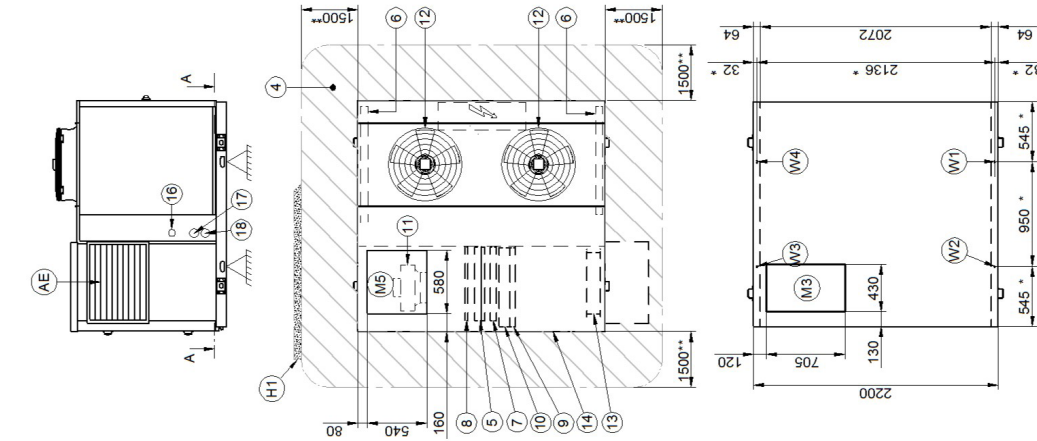

- Compressor compartment
 - Electrical panel
 - Condensate drain
 - Functional spaces
 - Internal exchanger
 - External exchanger
 - H2O heating coil / Electric heaters (Optional)
 - Reheat coil (Optional)
 - G4 air filters (Standard)
 - F7 / F9 / electronic filters (optional)
 - Electric fan (Supply)
 - External electric fan
 - Fresh air damper
 - Access for inspection of coils- filters - heating elements
 - Lifting brackets (removable)
 - Humidifier connections
 - H2O heating coil input Ø 3/4"
 - H2O heating coil output Ø 3/4"
 - Outdoor Air Return Cap (Optional) Accessory Separately Supplied
 - Power Input
- (M0) Horizontal air supply
(M3) Downward air supply (Optional)
(M5) Upflow air supply (Optional)
(AE) Fresh air inlet
(H1) Wall with same height as unit on a maximum of three sides
(*) Anti-vibration mount position
(**) Suggested minimum clearance

SIZE	12.2	16.2
W1 Supporting point	kg	350
W2 Supporting point	kg	266
W3 Supporting point	kg	289
W4 Supporting point	kg	368
Operating weight	kg	1273
Shipping weight	kg	1297

Sez. A-A

The presence of optional accessories may result in a substantial variation of the weights shown in the table

Dimensional drawings

Size 12.2 - 16.2 Combustion module - CCFFA configuration

DAA7Z12.2_16.2_CCFFA_GC01X-GC08X_02
Date: 13/02/2018

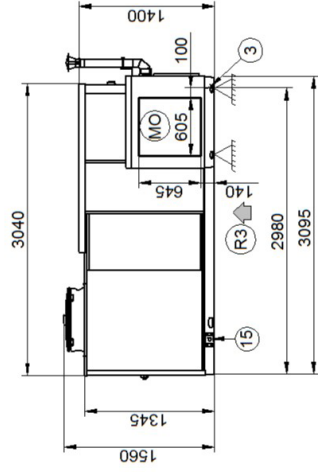
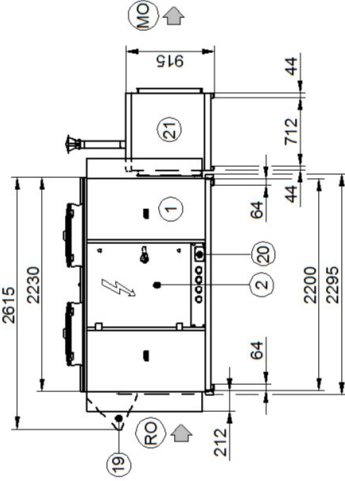
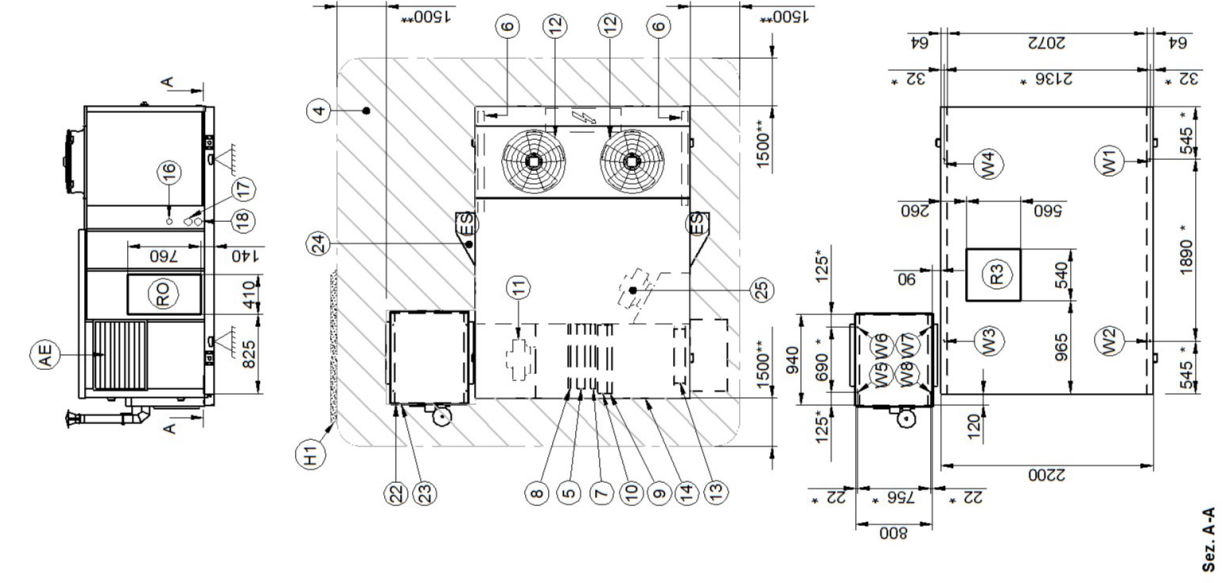

1. Compressor compartment
 2. Electrical panel
 3. Condensate drain
 4. Functional spaces
 5. Internal exchanger
 6. External exchanger
 7. H2O heating coil / Electric heaters (Optional)
 8. Reheat coil (Optional)
 9. G4 air filters (Standard)
 10. F7 / F9 / electronic filters (optional)
 11. Electric fan (Supply)
 12. External electric fan
 13. Fresh air damper
 14. Access for inspection of coils- filters - heating elements
 15. Lifting brackets (removable)
 16. Humidifier connections
 17. H2O heating coil input Ø 3/4"
 18. H2O heating coil output Ø 3/4"
 19. Outdoor air return cap (optional) accessory separately supplied
 20. Power input
 21. Gas module (accessory separately supplied)
 22. Gas connection UNI ISO 228/1 - G 3/4"
 23. Condensate drain (only for condensation gas heating module)
 24. Air exhaust caps (accessory separately supplied)
 25. Exhaust electric fan
- (ES) Air exhaust
(RO) Horizontal return
(R3) Downward air return
(MO) Horizontal air supply
(AE) Fresh air inlet
(H1) Wall with same height as unit on a maximum of three sides
- (*) Anti-vibration mount position
(**) Suggested minimum clearance

GAS MODULE WEIGHT DISTRIBUTION

SIZE	12.2	16.2	12.2 - 16.2
W1 Supporting point	kg	386	396
W2 Supporting point	kg	290	292
W3 Supporting point	kg	319	321
W4 Supporting point	kg	406	416
Operating weight	kg	1401	1425
Shipping weight	kg	1401	1425
W5 Supporting point	kg		70
W6 Supporting point	kg		58
W7 Supporting point	kg		58
W8 Supporting point	kg		70
Operating weight	kg		256
Shipping weight	kg		256

The presence of optional accessories may result in a substantial variation of the weights shown in the table

Size 20.4 - 22.4 - 24.4 - CBFFA configuration

DAA7Z20.4_22.2_CCBFA_01
Date: 13/02/2018

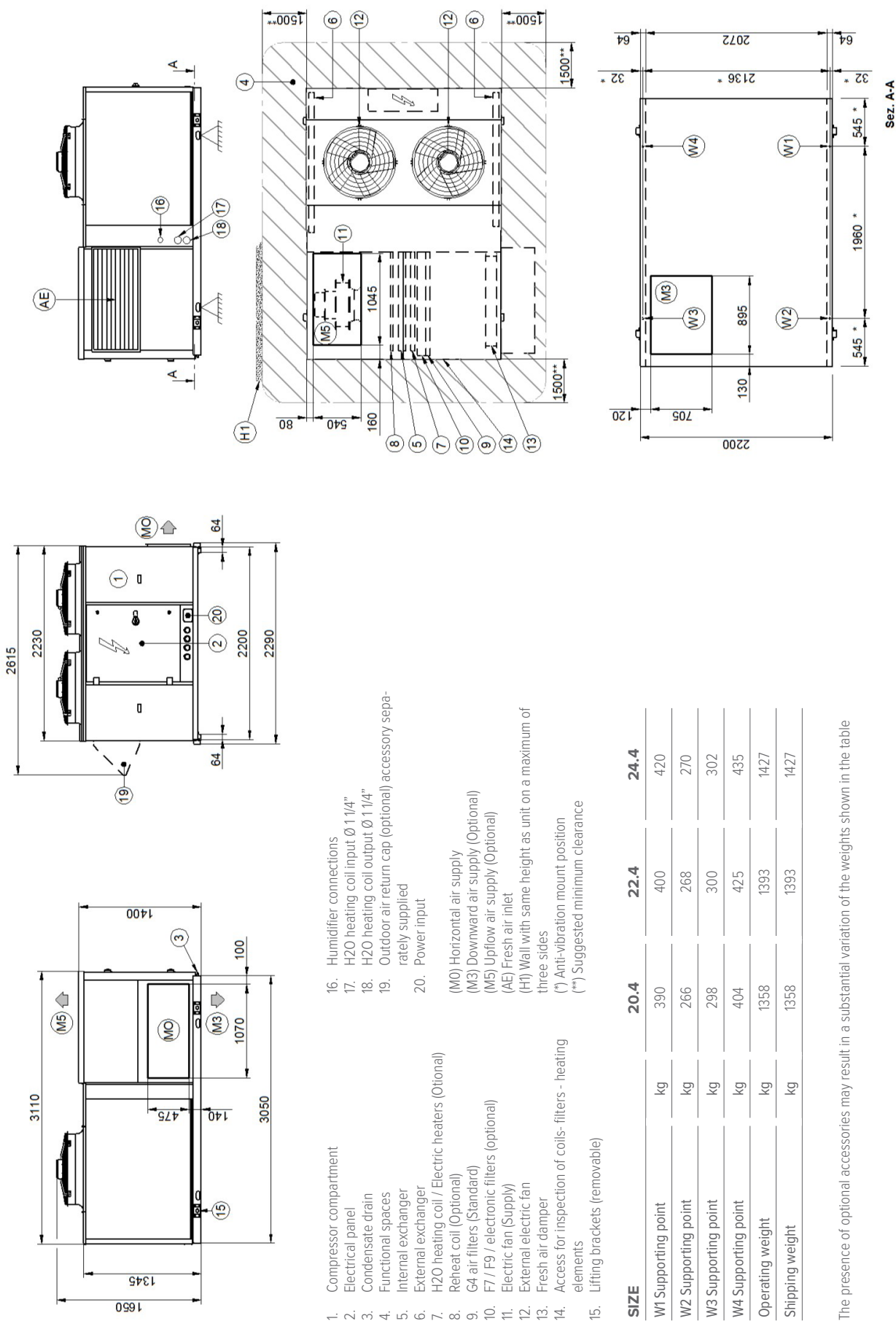

The presence of optional accessories may result in a substantial variation of the weights shown in the table

Dimensional drawings

Size 20.4 - 22.4 - 24.4 - Combustion module - CBFFA configuration

DAA7Z20.4_24.2_CBFFA_GC08X-GC10X_01
Date 13/02/2018

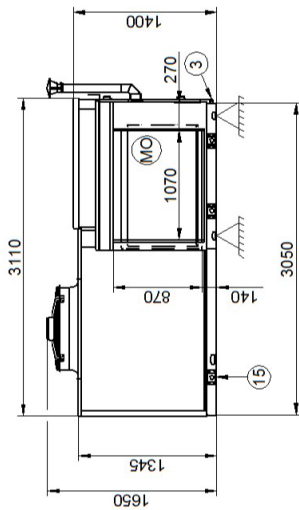
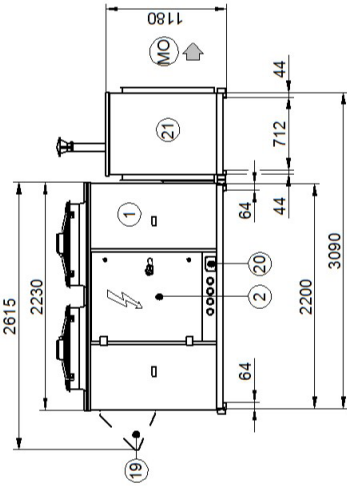
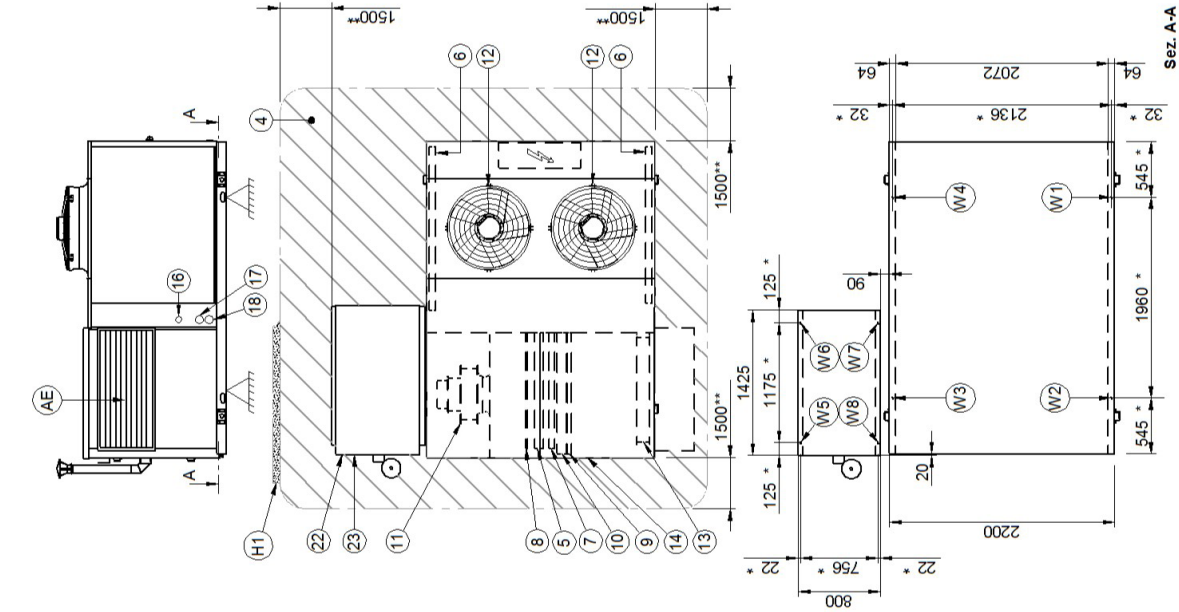

1. Compressor compartment
 2. Electrical panel
 3. Condensate drain
 4. Functional spaces
 5. Internal exchanger
 6. External exchanger
 7. H2O heating coil / Electric heaters (Optional)
 8. Reheat coil (Optional)
 9. G4 air filters (Standard)
 10. F7 / F9 / electronic filters (optional)
 11. Electric fan (Supply)
 12. External electric fan
 13. Fresh air damper
 14. Access for inspection of coils- filters - heating elements
 15. Lifting brackets (removable)
 16. Humidifier connections
 17. H2O heating coil input Ø 1 1/4"
 18. H2O heating coil output Ø 1 1/4"
 19. Outdoor air return cap (optional) accessory separately supplied
 20. Power input
 21. Gas module (accessory separately supplied)
 22. Gas connection UNI ISO 228/1 - G 3/4"
 23. Condensate drain (only for condensation gas heating module)
- (MO) Horizontal air supply
(AE) Fresh air inlet
(H) Wall with same height as unit on a maximum of three sides
(*) Anti-vibration mount position
(**) Suggested minimum clearance

GAS MODULE WEIGHT DISTRIBUTION

SIZE	20.4	22.4	24.4
W1 Supporting point	kg	390	420
W2 Supporting point	kg	266	270
W3 Supporting point	kg	298	302
W4 Supporting point	kg	404	435
Operating weight	kg	1358	1427
Shipping weight	kg	1358	1427

SIZE	20.4 - 22.4 - 24.4	
W5 Supporting point	kg	70
W6 Supporting point	kg	58
W7 Supporting point	kg	58
W8 Supporting point	kg	70
Operating weight	kg	256
Shipping weight	kg	256

The presence of optional accessories may result in a substantial variation of the weights shown in the table

Size 20.4 - 22.4 - 24.4 - CCFFA configuration

DAA7Z20.4_22.2_CCCFA_02
Date:13/02/2018

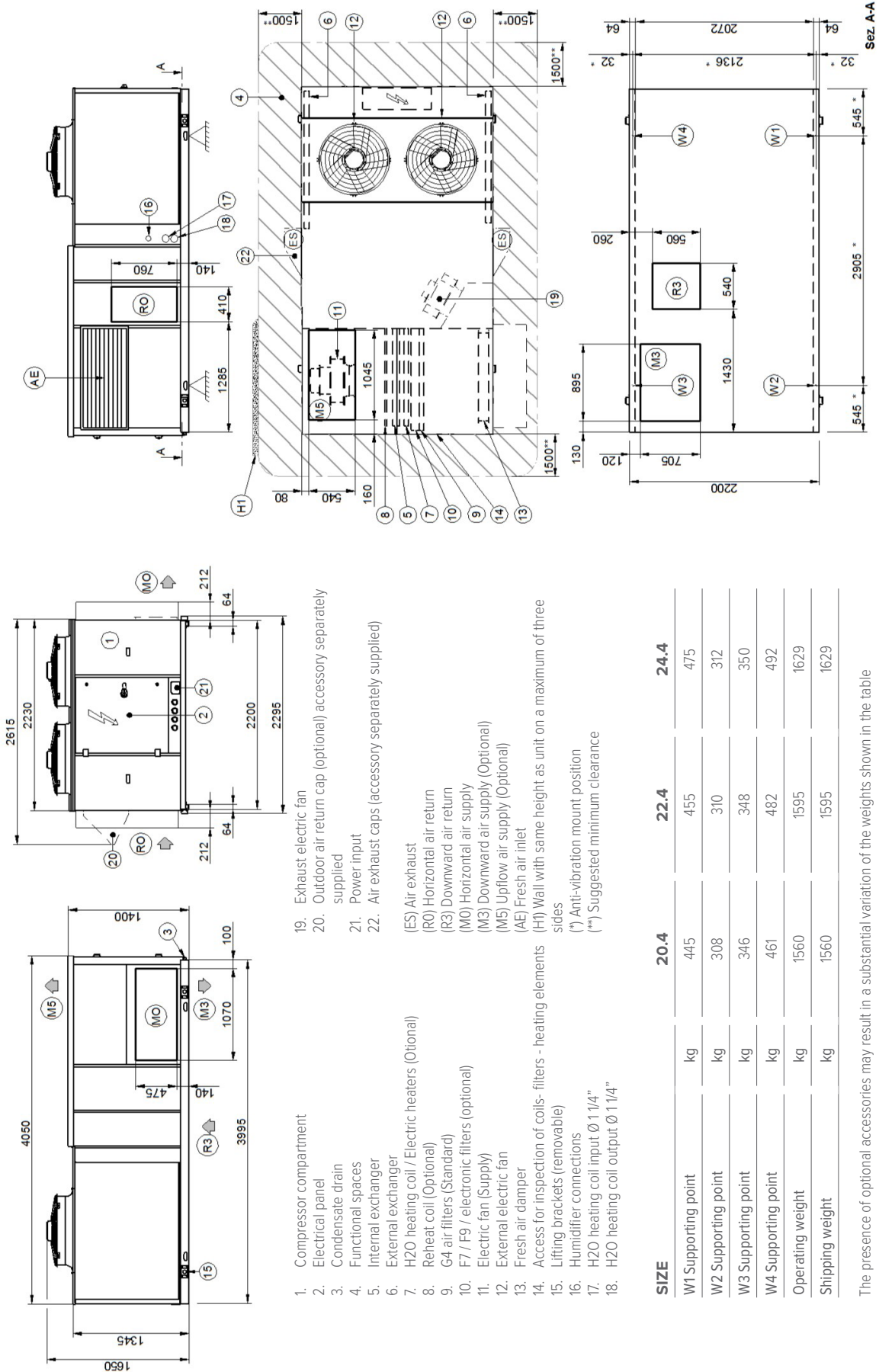

The presence of optional accessories may result in a substantial variation of the weights shown in the table

Dimensional drawings

Size 20.4 - 22.4 - 24.4 Combustion module - CCFFA configuration

DAA7Z20.4_24.2_CBFFA_GC08X-GC10X_02
Date 13/02/2018

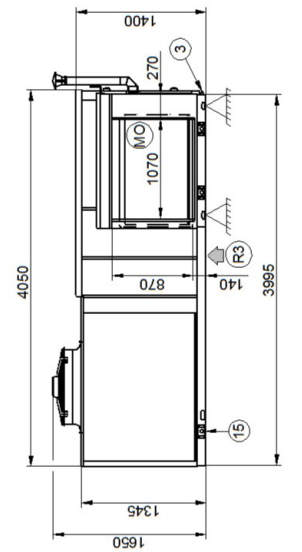
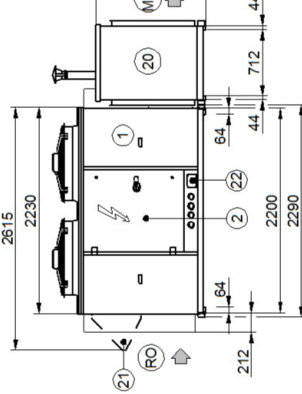
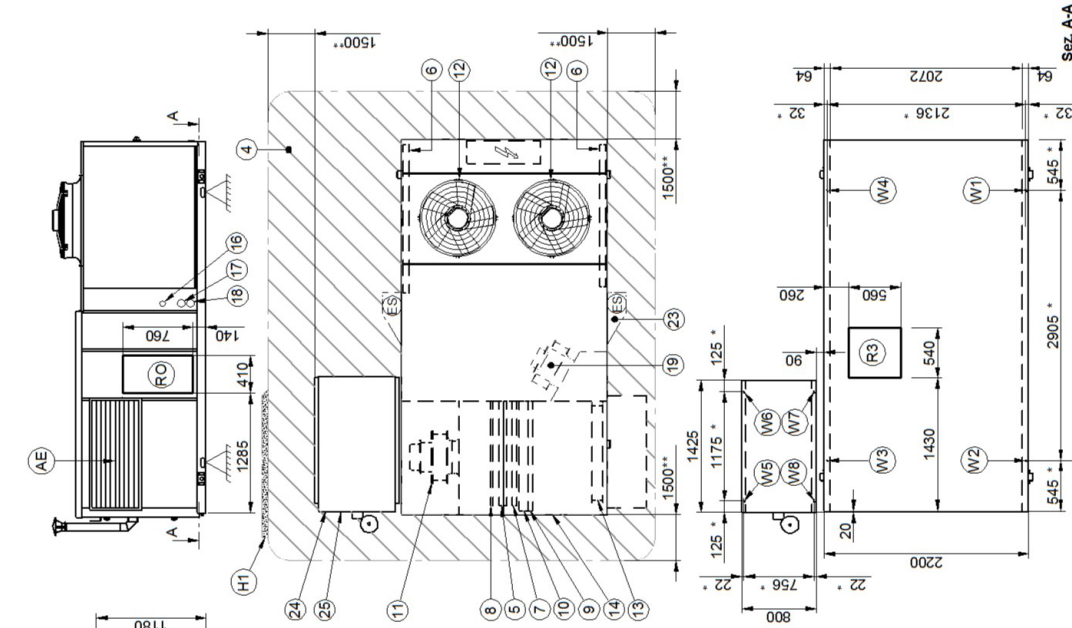

- 1. Compressor compartment
 - 2. Electrical panel
 - 3. Condensate drain
 - 4. Functional spaces
 - 5. Internal exchanger
 - 6. External exchanger
 - 7. H2O heating coil / Electric heaters (Optional)
 - 8. Reheat coil (Optional)
 - 9. G4 air filters (Standard)
 - 10. F7 / F9 / electronic filters (optional)
 - 11. Electric fan (Supply)
 - 12. External electric fan
 - 13. Fresh air damper
 - 14. Access for inspection of coils - filters - heating elements
 - 15. Lifting brackets (removable)
 - 16. Humidifier connections
 - 17. H2O heating coil input Ø 1 1/4"
 - 18. H2O heating coil output Ø 1 1/4"
 - 19. Exhaust electric fan
 - 20. Gas module (accessory separately supplied)
 - 21. Outdoor air return cap (optional) accessory separately supplied
 - 22. Power input
 - 23. Air exhaust caps (accessory separately supplied)
 - 24. Gas connection UNI ISO 228/1 - G 3/4"
 - 25. Condensate drain (only for condensation gas heating module)
- (ES) Air exhaust
(RO) Horizontal air return
(R3) Downward air return
(MO) Horizontal air supply
(AE) Fresh air inlet
(H1) Wall with same height as unit on a maximum of three sides
(*) Anti-vibration mount position
(**) Suggested minimum clearance

		GAS MODULE WEIGHT DISTRIBUTION					
SIZE	20.4	22.4	24.4	20.4 - 22.4 - 24.4			
W1 Supporting point	kg	445	455	475	W5 Supporting point	kg	70
W2 Supporting point	kg	308	310	312	W6 Supporting point	kg	58
W3 Supporting point	kg	346	348	350	W7 Supporting point	kg	58
W4 Supporting point	kg	461	482	492	W8 Supporting point	kg	70
Operating weight	kg	1560	1595	1629	Operating weight	kg	256
Shipping weight	kg	1560	1595	1629	Shipping weight	kg	256

The presence of optional accessories may result in a substantial variation of the weights shown in the table

Page intentionally left blank

FOR OVER 30 YEARS, WE HAVE BEEN
OFFERING SOLUTIONS TO ENSURE
SUSTAINABLE COMFORT AND THE
WELL-BEING OF PEOPLE AND THE
ENVIRONMENT



sales and assistance

www.clivet.com

MideaGroup
humanizing technology



CLIVET S.p.A.

Via Camp Lonc 25, Z.I. Villapaiera
32032 Feltre (BL) - Italy
Tel. +39 0439 3131 - info@clivet.it

CLIVET GMBH

Hummelsbütteler Steindamm 84,
22851 Norderstedt, Germany
Tel. +49 40 325957-0 - info.de@clivet.com

Clivet Group UK LTD

Units F5 & F6 Railway Triangle,
Portsmouth, Hampshire PO6 1TG
Tel. +44 02392 381235 -
Enquiries@Clivetgroup.co.uk

CLIVET LLC

Office 508-511, Elektroavodskaya st. 24,
Moscow, Russian Federation, 107023
Tel. +7495 6462009 - info.ru@clivet.com

CLIVET MIDEAST FZCO

Dubai Silicon Oasis (DSO), Headquarter Building,
Office EG-05, P.O BOX 342009, Dubai, UAE
Tel. +9714 3208499 - info@clivet.ae

Clivet South East Europe

Jaruščica 9b
10000, Zagreb, Croatia
Tel. +385916065691 - info.see@clivet.com

Clivet Airconditioning Systems Pvt Ltd

Office No.501 & 502,5th Floor, Commercial-I,
Kohinoor City, Old Premier Compound, Off LBS
Marg, Kirool Road, Kurla West, Mumbai
Maharashtra 400070, India
Tel. +91 22 30930200 - sales.india@clivet.com