

AQUA F

DSDH-P AQ 1 S 100



Installation and maintenance manual

en



ROMANIAN



BULGARIAN



SLOVENIAN



HRVATSKI

MDS00003-00 09-2025

Dear Customer,

We congratulate you on choosing this product.

Clivet has been working for years to offer systems able to assure the maximum comfort for a long time with highly-reliable, efficient, high-quality and safe solutions.

The target of the company is to offer advanced systems, that assure the best comfort and reduce energy consumption as well as the installation and maintenance costs for the entire life-cycle of the system.

With this manual, we want to give you information that is useful for all phases: from reception, installation and use to disposal - so that such an advanced system can provide the best performances during installation and use.

Best regards and have a good read.

CLIVET Spa

The original instructions are written in Italian.

All other languages are translations of the original instructions.

The data contained in this manual is not binding and may be changed by the manufacturer without prior notice. Reproduction, even partial, is FORBIDDEN.

© Copyright - CLIVET S.p.A. - Feltre (BL) - Italia.

Summary

1. General	5
1.1 About the manual.....	5
1.2 General safety warnings.....	6
2. About R-290 refrigerant	8
2.1 Warnings for the installer and the Technical Support Service.....	9
2.2 General warnings	9
2.3 Safety checks and procedures	9
3. Presentation of the product	14
3.1 Identification	14
3.2 Regulatory framework	14
3.3 Intended use	14
3.4 Description	14
3.5 Main components.....	15
4. Before installation	16
4.1 Prerequisites	16
4.2 Reception.....	16
4.3 Storage.....	16
4.4 Handling	17
4.5 Removal of the packaging	17
5. Installation	18
5.1 Prerequisites	18
5.2 General diagram	19
5.3 Clearances	20
5.4 Access to internal parts.....	21
6. Water connections	22
6.1 Prerequisites	22
6.2 Water characteristics.....	22
6.3 Cleaning.....	22
6.4 Piping insulation	22
6.5 Position of connections.....	23
6.6 Hydraulic connection	23
6.7 Water filter.....	23
6.8 Pressure reducing valve.....	24
6.9 Filling the water tank.....	24
6.10 Expansion tank.....	24
6.11 Pressure relief valve	24
6.12 Condensate drain	25
7. Aeraulic connections	26
7.1 Prerequisites	26
7.2 Unit fittings.....	26
7.3 Position of air ducts.....	26
7.4 Grille to prevent small animals or leaves from entering inside.....	28
8. Electrical connections	29

8.1	Prerequisites	29
8.2	Electrical connection	30
8.3	Connecting the power supply	30
8.4	Electric cable sizes	30
8.5	Wiring diagram	31
9.	Starting up the system.....	32
9.1	Refrigeration circuit.....	32
9.2	Water circuit	33
9.3	Aeraulic circuit.....	33
9.4	Electric circuit	33
9.5	Check voltages - Consumptions.....	33
9.6	TCO operation (temperature switch).....	33
9.7	Preliminary checks.....	34
10.	Start-up	35
10.1	Start-up report	35
10.2	2014/68/UE PED directive	35
11.	Maintenance	36
11.1	Prerequisites	36
11.3	Unit booklet.....	38
11.4	Standby mode	38
11.5	Emptying the water tank	38
11.6	Cleaning the outer coating.....	38
11.7	Power supply.....	38
11.8	Water filter.....	38
11.9	Expansion vessel.....	38
11.10	DHW temperature	38
11.11	Coil.....	39
11.12	Condensation collection basin.....	39
11.13	Air filter	39
11.14	Anodes	39
11.15	Replacing or checking the heater.....	40
11.16	Resetting the electric E-heater	41
12.	Decommissioning	42
12.1	Disconnection	42
13.	Residual risks	43
13.1	General.....	43
13.2	Danger zone.....	43
13.3	Handling	43
13.4	Installation.....	43
13.5	Refrigerant.....	44
13.6	Hydraulic parts.....	44
14.	Technical data	45
14.1	Dimensional	46

1. General

1.1 About the manual

- The manual ensures proper installation, use and maintenance of the unit
- this manual is an integral and essential part of the product
- keep this manual together with the wiring diagram in an accessible place for the operator. It should always accompany the product, even if it is transferred to another owner or user
- recipients of the instructions in the manual are indicated in the "Recipients" chapter
- the recipient is indicated at the beginning of each section of the manual
- recipients, to the extent of their responsibility, are required to read the instructions and warnings in this manual as they provide important information on safe installation, use and maintenance.

Remember that:

- the manufacturer accepts no liability for damage to persons or property resulting from failure to observe the rules in this manual
- failure to observe the instructions in this manual will result in forfeiture of the warranty
- the manufacturer reserves the right to make changes or improvements to this documentary material and to the units without prior notice
- visit the manufacturer's website for up-to-date details
- this manual contains proprietary information, all rights reserved, it may not be reproduced or photocopied, either in whole or in part, without the prior written consent of manufacturer.

1.1.1 Symbols

The symbols in the following chapter can be found in the manual and on the product, and provide quick and clear information for correct and safe use.

1.1.1.1 Safety symbols

Danger

This symbol indicates warnings, failure to comply may result in serious harm to health and fatal injuries.

Warning

This symbol indicates warnings, failure to comply may result in irreparable damage to the product or harm to the environment.

Prohibition

This symbol indicates operations that must never be carried out.

Note

This symbol indicates important information.

1.1.1.2 Editorial symbols

In the texts

Purpose of the action: indicates the purpose of a sequence of actions.

(it is identified by bold text followed by :)

- ▶ this symbol indicates actions that are required
- this symbol indicates the expected result after an action
- this symbol indicates the lists

In the images

1 uniquely indicates a component

 indicates a group of components

 indicates a sequence of actions

In the images, dimensions are expressed in millimetres unless otherwise indicated.

1.1.1.3 Symbols on the unit

The following symbols are used in some parts of the product:

Caution flammable material:

The refrigerant gas is flammable and odourless. Do not place it near continuously operating ignition sources (naked flames, gas appliances, electric stoves, lit cigarettes, etc.).

Instructions for the User

Read the User Manual carefully before using the product.

Instructions for the User

Read the Installer Manual carefully before installing the product.

Instructions for the Technical Support Service

Read the Technical Support Service Manual carefully before carrying out any operation on the product.

1.1.2 Recipients

1.1.2.1 User

Inexperienced person who is capable of:

- operating the product safely for people, for the product and for the environment
- interpreting elementary diagnostics of faults and abnormal operating conditions
- carrying out simple adjustment, test and maintenance operations.

1.1.2.2 Installer

Experienced and qualified person able to:

- to put the product in a safe operating condition for people, for the product and for the environment
- to comply with the regulations in force in the country of destination
- to provide the user with basic information on safe use and maintenance in accordance with this manual and current national regulations
- comply with the regulations in force in the country of destination.

1.1.2.3 Technical support service

Experienced person, qualified and authorised directly by the manufacturer to:

- carry out a diagnosis of product faults and abnormal operation, possibly using information provided by the user
- rectify faults, carrying out the necessary repairs, replacements and adjustments that will restore the product's ability to function correctly and safely for the people, for the product and for the environment
- comply with the regulations in force in the country of destination.

1.1.3 Document organisation

- The manual is divided into sections, each dedicated to one or more recipients
- the recipient is indicated at the beginning of each section of the manual.

1.2 General safety warnings

 Read the "About the manual" chapter carefully before proceeding with any operation.

 Each chapter contains specific warnings for the operations given therein. These warnings should be read before starting any activities.

 For every operation, always comply with

current national regulations.

 All personnel must be aware of the operations and of the hazardous situations that may arise when starting any operations on the unit.

 Any contractual and non-contractual liability for damage caused to persons, animals or property by installation, adjustment or maintenance errors or improper use is excluded.

 Any uses not expressly indicated in this manual are not permitted.

 Do not change or tamper with the device as this can lead to hazardous situations.

 Use appropriate safety clothing and equipment.

 The manufacturer accepts no liability for failure to comply with current safety and accident prevention regulations.

 The manufacturer reserves the right to make changes to its models at any time to improve its product, subject to the essential characteristics described in this manual.

 The manufacturer is not obliged to add these changes to units previously manufactured, already delivered or being built.

 The unit is suitable for use by children aged 8 years and over and by persons with reduced physical, sensory or mental capabilities or lack of experience or knowledge if they are properly supervised or have received instructions on the safe use of the device and have understood the associated hazardous situations. Children must not play with the device. Cleaning and maintenance operations must not be carried out by children without supervision.

 It is forbidden to touch the device with wet or damp parts of the body.

- ⊖ It is forbidden to carry out any operation before disconnecting the device from the mains power supply by turning the system's main switch to "off".
- ⊖ It is forbidden to change the safety or control devices without the device manufacturer's authorisation and instructions.
- ⊖ It is forbidden to pull, unplug or twist the electrical cables coming out of the device, even if it is disconnected from the mains power supply.
- ⊖ It is forbidden to introduce objects and substances through the air intake and supply grills.
- ⊖ It is forbidden to open the access doors to internal parts of the unit without first turning the system's main switch to "off".

2. About R-290 refrigerant

This section contains specific safety information and warnings on the use of R-290 refrigerant.

 For more comprehensive information, read the safety data sheet for the refrigerant used.

 The refrigerant used inside this unit is highly flammable. A refrigerant leak that is exposed to an external ignition source can create fire risks.

Quantity of refrigerant charged at the factory and tons of equivalent CO₂:

Size	Refrigerant quantity charged at the factory
	Refrigerant / kg
100	0,150

Physical characteristics of R-290 refrigerant

Safety class (ISO 817)	A3	
GWP (Global Warming Potential)	0,02	t CO ₂ eq, 100yr
LFL Low flammability limit	1,7 - 10,8	vol % in air
BV Burning velocity	6,7	cm/s
Normal boiling point	-42,1	°C
Self-ignition temperature	470	°C

2.1 Warnings for the installer and the Technical Support Service

 The use of flammable refrigerants entails specific safety warnings for certain operations during installation and maintenance.

2.2 General warnings

 The refrigerant used inside this unit is highly flammable. A refrigerant leak that is exposed to an external ignition source can create fire risks.

 Before starting work on systems containing flammable refrigerants, safety checks must be carried out to ensure that the risk of combustion is minimised.

 Installation and maintenance personnel and other people working in the area should be informed about the nature of the work to be done.

 Do not pierce or burn.

 The unit must be protected from accidental impacts so as to prevent mechanical damage that would cause a refrigerant leak.

 Ensure that there are no continuously operating ignition sources (naked flames, gas appliances, electric stoves, lit cigarettes, etc.).

 Do not place flammable objects (e.g. spray cans) within 1 metre of the exhaust air.

2.3 Safety checks and procedures

Before starting an intervention, carry out appropriate safety checks to ensure that the risk of ignition is minimal. Follow these precautions before starting an intervention:

2.3.1 Checks in the area

Perform the following checks:

- carry out safety checks to ensure that the risk of combustion is minimised
- avoid working in tight spaces
- mark the area around the work space
- ensure safe working conditions around the area and check that there is no flammable material.

2.3.2 Work procedures

- Interventions must be carried out according to a controlled procedure in order to minimise the risk of flammable gases or vapours being present during the work.

2.3.3 Checking the presence of refrigerant

Perform the following checks:

- the area must be checked using an appropriate refrigerant detector before and during the intervention so that the technician is aware of potentially flammable atmospheres
- check that the leak detector is suitable for use with flammable refrigerants (it does not generate sparks and is adequately sealed or intrinsically safe)
- check that it is placed in a suitable space to promptly check for leaks linked to the maintenance activity carried out

 It is forbidden to use leak detectors with halogen lamps.

 Remember that R-290 refrigerant is heavier than air and tends to stratify.

2.3.4 Presence of fire extinguishers

When performing hot operations on refrigeration equipment or associated components:

- keep a suitable extinguisher at hand
- keep a dry-powder or CO₂ extinguisher near the work area.

2.3.5 Absence of ignition sources

When operations to be carried out on a refrigeration system involve exposing piping containing or having contained a flammable refrigerant.

Perform the following checks:

- all possible ignition sources, including cigarette smoke, should be kept at a sufficient distance from the installation, fixing, disassembly and disposal site, as flammable refrigerant may escape into the surrounding space during these operations.
- before starting the intervention, the area around the unit must be inspected to check that it does not present ignition or flammability hazards.

 It is forbidden to use any ignition source that could generate a risk of fire or explosion.

 It is forbidden to smoke near the unit. "NO SMOKING" signs must be affixed.

- ⊖ It is forbidden to use a mobile phone near the unit.

2.3.6 Area ventilation

Before working on the system or performing hot operations.

Perform the following checks:

- the area must either be open or adequately ventilated
- ventilation must be constant throughout the entire operation and be capable of safely dispersing all refrigerant released and preferably expelling it outside into the atmosphere.

2.3.7 Checks on the refrigeration system

Perform the following checks:

- if an electrical component is replaced, the new one must be suitable for the intended use and in accordance with the correct specifications
- follow the manufacturer's maintenance and service instructions in all circumstances
- when in doubt, consult the manufacturer's technical department
- the charge volume must be suitable for the room volume and the intended use in which the components containing the refrigerant are installed, see the electrical installation requirements in EN 378
- ventilation devices and openings must open properly and not be obstructed
- if an indirect refrigerant circuit is used, the presence of refrigerant in the secondary circuits must be checked
- equipment markings must remain visible and legible
- markings and indications that become illegible must be corrected
- pipes or other components of the refrigerant circuit must be installed in locations where exposure to potentially corrosive substances is unlikely for components containing the refrigerant, unless they are made of materials inherently resistant to corrosion or adequately protected against the risk of corrosion.

2.3.8 Checks on electrical devices

Remember that:

- the fixing and maintenance procedures for electrical components must include initial safety checks and component inspection procedures
- if a defect is found that may generate safety risks, the power supply to the circuit must be interrupted until the problem is satisfactorily resolved
- if the problem cannot be solved immediately, but it is necessary to keep the system in operation, an appropriate temporary solution must be adopted
- the situation should be communicated to the owner

of the unit so that all persons concerned can be duly informed

Carry out the following checks:

- check that the capacitors are discharged: this procedure must be performed safely to avoid the possibility of sparks
- check that there are no live components or wires exposed while charging, resetting or venting the system
- check for ground fault interruptions
- check that the unit is not powered and if necessary disconnect the power supply before proceeding with the next steps

2.3.9 Fixing sealed components

Remember that:

- all electrical users must be disconnected from the equipment before removing the seal covers, etc.
- if it is absolutely necessary to have a power supply during the intervention, a permanent leak detection method must be set up at the most critical point to signal any potentially dangerous situations
- the use of silicone sealants may make some types of leak detection equipment less effective.

Ensure that:

- the casing must not be altered to such an extent that the required level of protection is compromised, including damage to cables, excessive number of connections, use of terminals that do not conform to the original specifications, damage to seals, incorrect assembly of glands, etc.
- the device must be installed safely.
- seals or sealing materials have not deteriorated to such an extent that they no longer ensure a perfect seal keeping flammable atmospheres from entering
- spare parts must comply with the manufacturer's specifications.

2.3.10 Fixing intrinsically safe components

Remember that:

- before applying capacitance or permanent inductance loads to the circuit, check that this operation does not result in the permissible voltage and current values for the equipment in use being exceeded
- intrinsically safe components are the only types of components that can be operated under voltage in the presence of a flammable atmosphere
- the test device must have the correct nominal characteristics
- only use parts specified by the manufacturer to replace components
- other components can cause ignition of the refrigerant

released into the atmosphere.

2.3.11 Wiring

Check that:

- the wiring must not be exposed to wear, corrosion, excessive pressure, vibration, sharp edges or other adverse environmental influences.

i The check should also take into account the effects of ageing or continuous vibration from compressors, fans or other similar sources.

2.3.12 Detection of flammable refrigerants

- ⊖** The use of potential ignition sources for the search or detection of refrigerant leaks is prohibited under any circumstances.
- ⊖** The use of halogen torches or other naked flame detection systems is not permitted.

2.3.13 Leak detection methods

Remember that:

- electronic leak detectors can be used to detect flammable refrigerants, but their sensitivity may not be adequate or require recalibration
- detection equipment must be calibrated in a refrigerant-free area
- the detector is not a potential ignition source and is suitable for the refrigerant
- leak detection equipment must be configured at a percentage of the lower flammability limit (LFL) of the refrigerant and be calibrated for the refrigerant used with confirmation of the appropriate gas percentage (max. 25%)
- leak detection fluids are suitable for use with most refrigerants but the use of detergents containing chlorine should be avoided, as chlorine can react with the refrigerant and corrode copper piping.

If there is a refrigerant leak:

- remove or extinguish all naked flames
- if brazing is required, all of the refrigerant must be removed from the system, or isolated (by means of shut-off valves) in a part of the system away from the leak
- purge the system with oxygen-free nitrogen (OFN) both before and during brazing.

2.3.14 Removal and evacuation

Follow the procedure below:

- ▶ remove the refrigerant
- ▶ purge the circuit with inert gas
- ▶ evacuate
- ▶ purge again with inert gas
- ▶ open the circuit by cutting or brazing

Remember that:

- the refrigerant charge can be recovered in the appropriate cylinders
- the system must be purged with oxygen-free nitrogen to make the unit safe
- it may be necessary to repeat this procedure several times
- compressed air or oxygen must not be used for this operation
- purging can be performed by introducing oxygen-free nitrogen into the vacuum circuit in the system and continuing to fill until the operating pressure is reached, then venting into the atmosphere and recreating the vacuum
- this procedure must be repeated until the refrigerant is completely exhausted from the system.

When the last charge of OFN is added:

- the system must be vented to barometric pressure to allow the work to be performed
- i** This operation is absolutely essential if brazing operations are to be carried out on the piping.
- check that the vacuum pump outlet is not closed for any ignition source and that good ventilation is available.

2.3.15 Charging operations

Remember that:

- when using charging equipment, avoid contamination with different refrigerants
- cylinders must be kept upright
- before the refrigerant is charged into the system, ensure that it is properly earthed
- the system must be labelled after charging (if the label is not already present)
- extreme care must be taken to avoid overfilling or underfilling the system
- before recharging the system, the pressure must be tested using oxygen-free nitrogen
- after charging, but before start-up, the system should not

leak

- an additional check for leaks must be carried out before leaving the site.

2.3.16 Decommissioning

Remember that:

- before performing this procedure, it is essential that the technician is fully familiar with the equipment and all of its components
- all refrigerants must be recovered following safe procedures
- an oil and refrigerant sample must be taken before proceeding
- before reusing the recovered refrigerant, it should be analysed
- before starting the procedure, it is essential to check that the power supply is available
- electrically isolate the system.

Before proceeding, check that:

- mechanical equipment for handling refrigerant cylinders is available, if necessary
- the necessary personal protective equipment is available and is used
- the recovery process is carried out under the constant supervision of a competent person
- the recovery equipment and cylinders comply with the regulations in force.

To recover:

- if possible, transfer the refrigerant to the unit using a "pump-down" procedure
- if it is not possible to create a vacuum, use a manifold that allows the refrigerant to be exhausted from various parts of the system
- place the cylinder on the scale
- start the recovery device and use it according to the manufacturer's instructions
- do not fill the cylinders excessively. (Do not exceed 80% of the liquid volume)
- do not exceed the maximum working pressure of the cylinder, even temporarily
- after filling the cylinders correctly and completing the procedure, transfer the cylinders and equipment from the site as soon as possible and close all shut-off valves on the equipment.
- before charging the recovered refrigerant into another refrigeration system, it must be cleaned and checked.

2.3.17 Labelling

Remember that:

- the device must be labelled to indicate that it has been decommissioned and emptied of refrigerant
- the label must be dated and signed
- check that labels indicating the content of flammable refrigerant are affixed to the device.

2.3.18 Recovery

When discharging refrigerant from a system for maintenance or decommissioning reasons.

Check that:

- the refrigerant is removed safely
- only cylinders suitable for refrigerant recovery are used
- the number of cylinders required to hold the entire system charge is available
- all cylinders to be used are designed for the refrigerant recovered and labelled for that refrigerant (special refrigerant recovery cylinders)
- the cylinders are equipped with a pressure relief valve and well-functioning shut-off valves
- empty recovery cylinders are evacuated and, if possible, cooled before recovery
- the recovery equipment is in good working order, accompanied by a set of instructions at hand, and suitable for the recovery of flammable refrigerants
- a set of well-functioning calibrated scales is provided
- the pipes are complete with decoupling fittings that are leak-free and in good condition
- the recovery equipment is in good working order, has been properly maintained and the associated electrical components are sealed to prevent a risk of ignition in the event of refrigerant leakage. If in doubt, consult the manufacturer.
- the refrigerant is returned to the supplier in the correct recovery cylinders, accompanied by the relevant waste identification form
- different types of refrigerant are not mixed in the recovery units, especially in the cylinders
- if compressors or compressor oils are decommissioned, evacuate them to an acceptable level to prevent flammable refrigerant from remaining inside the lubricant
- the evacuation procedure is carried out before returning the compressor to the suppliers
- only the electric heating on the compressor body is used to accelerate this process
- when oil is extracted from the system, it is drained using a safe procedure.

2.3.19 Transportation, marking, storage and disposal of units

- comply with current national regulations.

2.3.20 Receipt and handling

On receipt of the unit:

- check if there is refrigerant inside the packaging using an electronic leak detector suitable for the system refrigerant
- if there is, it is likely that the refrigerant circuit is damaged
- In this case, the unit must not be installed and the Technical Support Service must be called.

3. Presentation of the product

3.1 Identification

The serial number label is positioned on the unit and allows to identify all the unit features.

The matriculation plate shows the indications foreseen by the standards, in particular:

- unit type
- serial number
- year of manufacture
- wiring diagram number
- electrical data
- manufacturer logo and address

 The serial number uniquely identifies each unit and enables specific parts to be identified.

 Tampering, removal, missing identification labels or anything else that does not allow the product to be safely identified, makes installation and maintenance operations difficult.

3.2 Regulatory framework

The relevant regulatory framework can be found in the declaration of conformity enclosed with this document.

3.3 Intended use

The units are designed for:

- indoor installation
- operation within the limits and with their performance characteristics set out in this document and in the bulletin.

3.4 Description

Packaged heat pump for domestic hot water production.

3.5 Main components

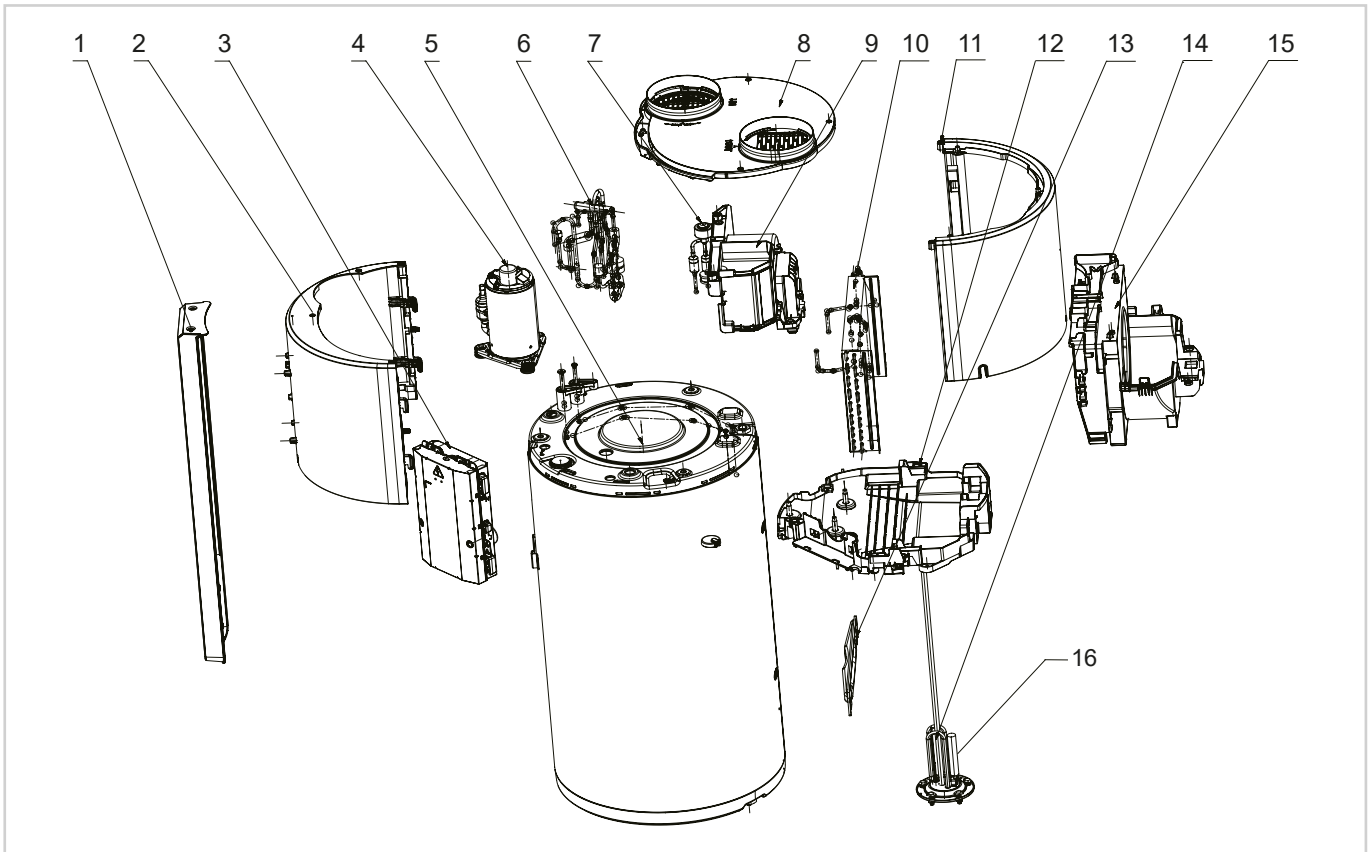

No.	Component
1	Front panel
2	Top part front cover
3	Electrical panel
4	Compressor
5	DHW tank
6	4-way valve
7	Electronic expansion valve
8	Upper panel
9	Upper electrical panel
10	Evaporator
11	Top part back cover
12	Condensation drain pan
13	Fixing bracket
14	Electric heater
15	Fan cover
16	Anode

i The images are provided for illustrative purposes only.

4. Before installation

4.1 Prerequisites

- ⚠ This section is intended exclusively for the Installer.
- ⚠ Refer to the Technical data chapter for details.
- ⚠ When handling the unit, use equipment appropriate to the weight of the unit.
- ⚠ Check that all handling equipment complies with local safety regulations (crane, forklifts, ropes, hooks, etc.).
- ⚠ During manual operations, it is mandatory to comply with the maximum weight per person as required by current legislation.
- ⚠ Provide personnel with personal protective equipment appropriate for the situation, such as hard hat, gloves, safety shoes, etc.
- ⚠ Observe all safety procedures in order to guarantee the safety of the personnel present and the material.
- ⚠ To avoid injury, do not touch the unit's air inlet or aluminium fins.
- ⚠ Do not touch the fins or other components with your fingers.
- ⚠ Do not use the fan grills handles to move the unit.
- ⚠ Keep the unit packed during handling.
- ⚠ Remove the packaging when you have reached the point of installation.

4.2 Reception

Before accepting the delivery, check:

- that the unit has not been damaged during transport
- that the materials delivered match those indicated on the transport document, comparing the data with the serial number label on the packaging.

In case of damage or anomaly:

- immediately write down the damage found on the transport document and quote this sentence: "Accepted with reservation due to evident shortages/damages during transport"
- refer to the contractual document.

- ⓘ Any disputes must be made within 8 days from the date of the delivery. Complaints after this period are invalid .

4.3 Storage

Respect the indications on the outside of the pack.

In particular:

- minimum ambient temperature -10 °C
- maximum ambient temperature +50 °C
- maximum relative humidity 95%

- ⚠ Exceeding these limits can cause irreversible damage to the unit.

4.4 Handling

The unit can be handled:

- with a forklift truck or pallet truck
- stair climbing trolley

The following examples are guidelines; the choice of means and handling modes will depend on the actual installation situation.

Lifting with a forklift truck

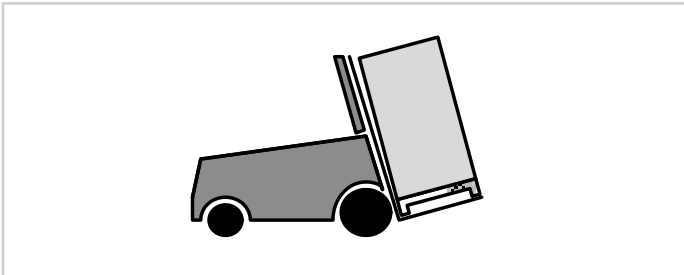

Stair climbing trolley



- ⚠ When the load is lifted off the ground, stay clear of the area below and around it.
- ⚠ The unit may not be tilted more than 30° during transport.
- ⚠ Identify critical points during handling (disconnected routes, flights, steps, doors).
- ⚠ Before starting the handling, make sure that the unit is stable.
- ⚠ If the unit was tilted during transport, wait at least 2 hours before start-up.
- ⓘ To avoid scratching or deforming the unit's surface, cover it with protective panels.

4.5 Removal of the packaging

On reaching the installation site.

Carry out the following procedure:

- ▶ cut the straps
- ▶ remove the cardboard

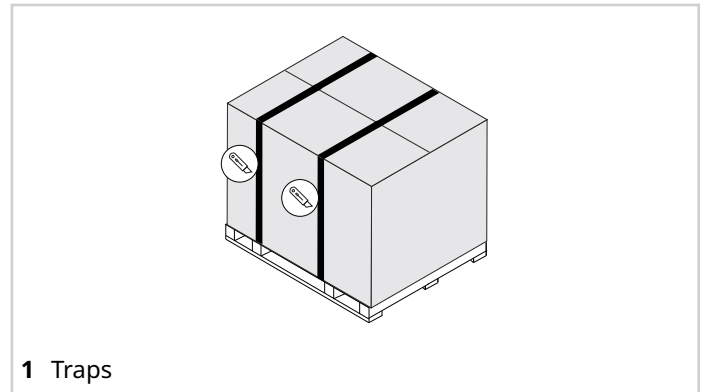

- ⚠ Be careful not to damage the unit.
- ⚠ Keep the packaging material out of children's reach as it may be dangerous.
- ♻ Recycle and dispose of the packaging material in conformity with local regulations.

5. Installation

5.1 Prerequisites

 This section is intended exclusively for the Installer.

 Refer to the Technical data chapter for details.

 The electrical system and its components must be designed by a qualified technician who must work according to the rules of good practice and national regulations.

 **Ensure that:**

- the location can be accessed safely
- any furniture or other objects can be moved easily in the event of maintenance
- the clearances are guaranteed
- there is an area free from obstacles that could affect the circulation of inlet and outlet air and free from exposure to strong wind
- the support surface or the wall can withstand the weight of the unit
- the floor or wall section does not interfere with power lines or water piping and no load-bearing elements of the construction are compromised
- the operating noise and exhaust air flow must not disturb neighbours
- the unit is securely anchored to prevent excessive noise and shaking
- the area around the unit is free from obstacles
- if the unit is to be installed on a metal section of a building, the electrical insulation is in accordance with applicable electrical regulations.

 **Avoid therefore:**

- places that may be subject to flooding
- areas near to heat sources
- damp environments and areas with probable contact with water
- using air from heated environments so as not to adversely affect the thermal performance of the building

 The unit cannot be installed outdoors or in a room/compartment where the temperature can fall below 0°C.

 If the unit is installed in a place where the ambient temperature is higher than 35°C, provide adequate ventilation in the room.

 It is also advisable to check the outdoor temperature during installation: in heat pump mode it must be higher than -7°C and lower than 43°C.

 If the outdoor temperature is outside these limits, the electric heaters are activated to fulfil the hot water demand, thus preventing the heat pump from operating.

 The unit must be placed in an area not exposed to freezing temperatures.

 If the unit is located in an area that is not air-conditioned (e.g. garage, cellar, etc.), it may be necessary to insulate the water, condensate and drainage piping to protect it from frost.

 **Installing the unit in one of the following places can lead to malfunctions:**

- sites containing mineral oils such as lubricants
- by the sea where the air is salty
- thermal areas where there are corrosive gases
- industries where voltage strongly fluctuates
- sites with direct sunlight or other heat sources. If there is no other way, install a cover
- sites with oil in the air (e.g. kitchens)
- sites with strong electromagnetic fields
- sites with flammable gases or materials
- sites with acid or alkaline gas vapours.

5.2 General diagram

Wall installation

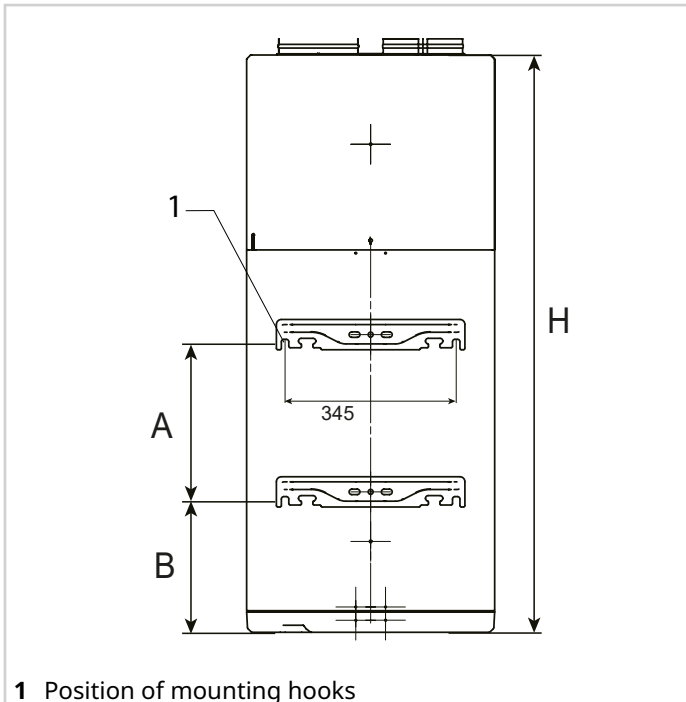

Size		A	B	H
100	mm	415	277	1333

⚠ Fix using mounting hooks and expansion anchor bolts suitable for the characteristics of the support surface and capable of withstanding the load.

i Mounting hooks and expansion anchor bolts are supplied.

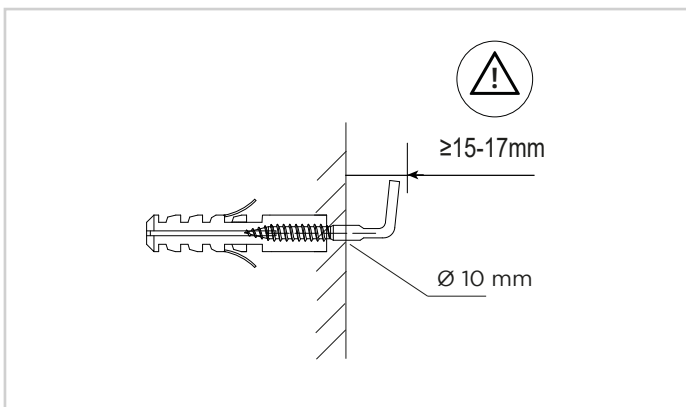

Installation on a load-bearing wall



Installation on a non-load-bearing wall



⚠ The support must be installed under the unit.

⚠ The wall must withstand a minimum load of 300 kg.

5.3 Clearances

The clearances for installation and maintenance of the unit are shown in the figure.

⚠ The unit must be placed in a space >15m³ and the airflow must not be obstructed.

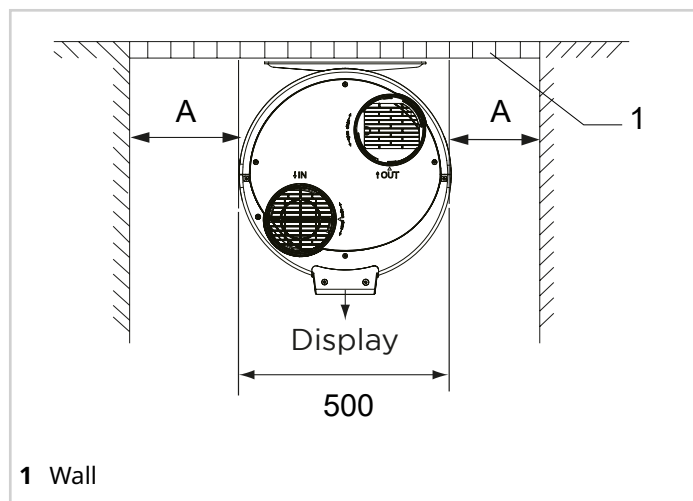

A	mm	≥ 350
B	mm	≥ 300
C	mm	≥ 350
D	mm	≥ 450

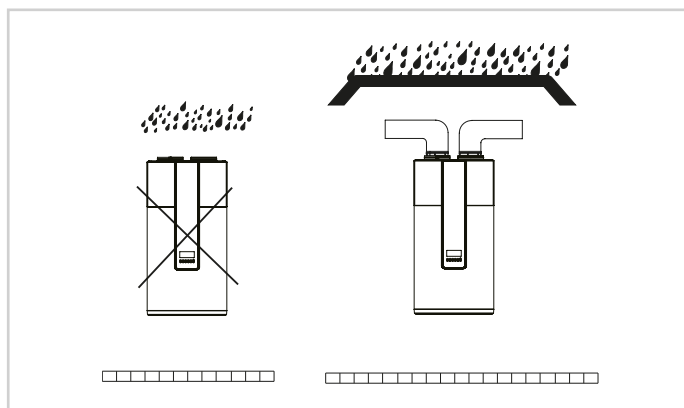
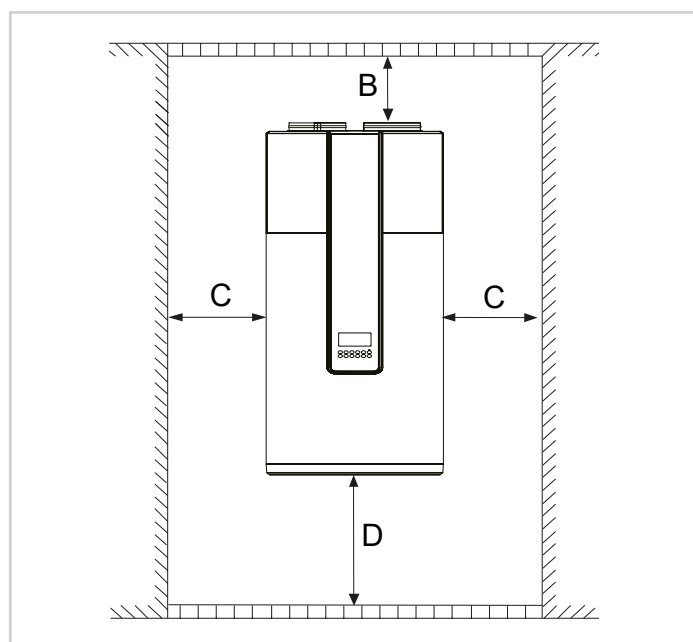

⚠ Install the unit indoors; it must not be installed in an area that is not protected from the rain.

⚠ Should rain enter the unit, components could get damaged and cause failure.

Levelling

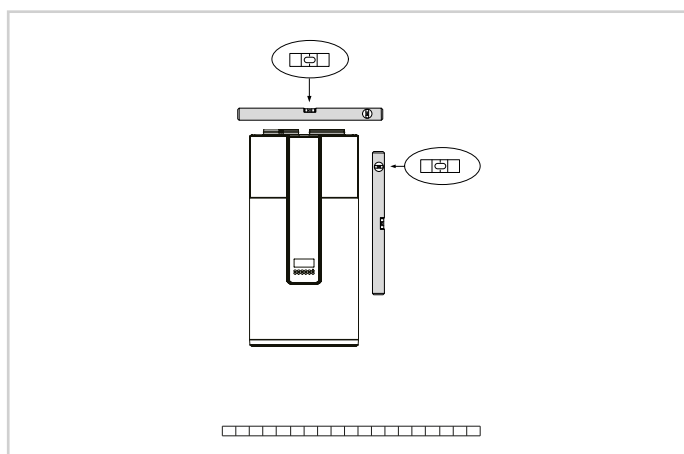

Electrical socket

Install the electrical socket at a height of 1.5 m, making sure it is far from water sources.

Provide a mains socket (plug + ON/OFF switch) near the unit.

The plug must be accessible at all times.

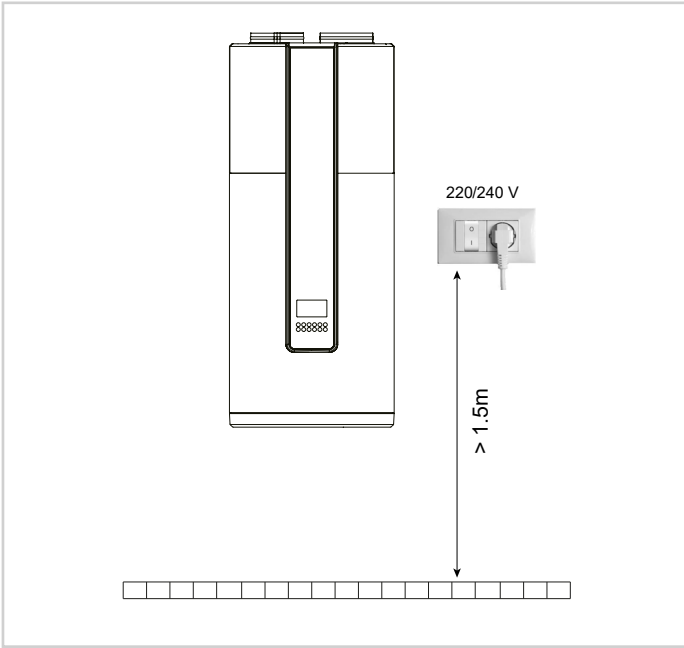

- ▶ unscrew the fixing screws
- ▶ remove the metal support
- ▶ remove the screws from the front of the top part
- ▶ lift upwards
 - to access the electrical panel:
 - remove the two screws on the top of the control panel
 - open the electrical panel
- ▶ remove the remaining screws on the top part
- ▶ remove the remaining panels

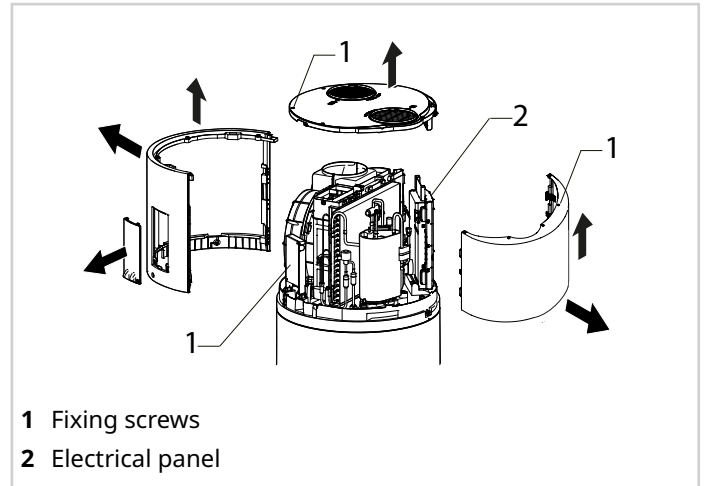

- 1 Fixing screws
- 2 Electrical panel

5.4 Access to internal parts

To access the electrical panel

- ▶ remove the access panel

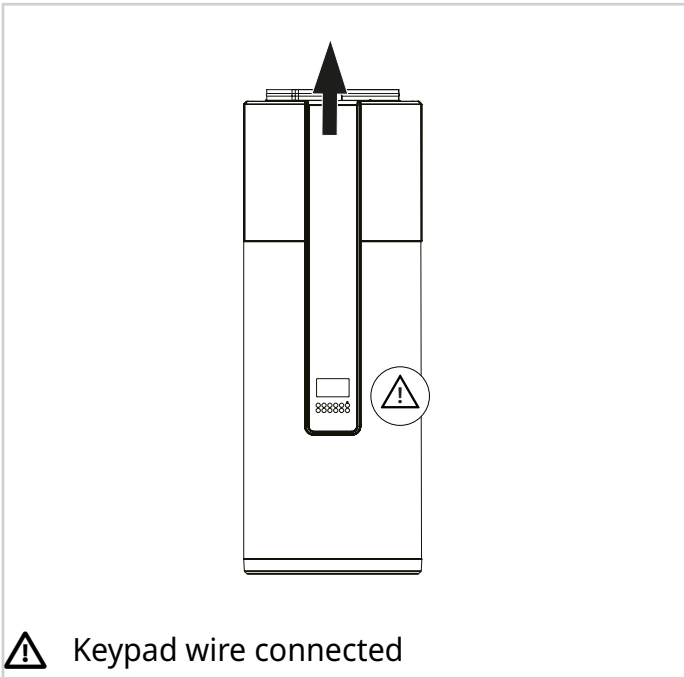

⚠ Keypad wire connected



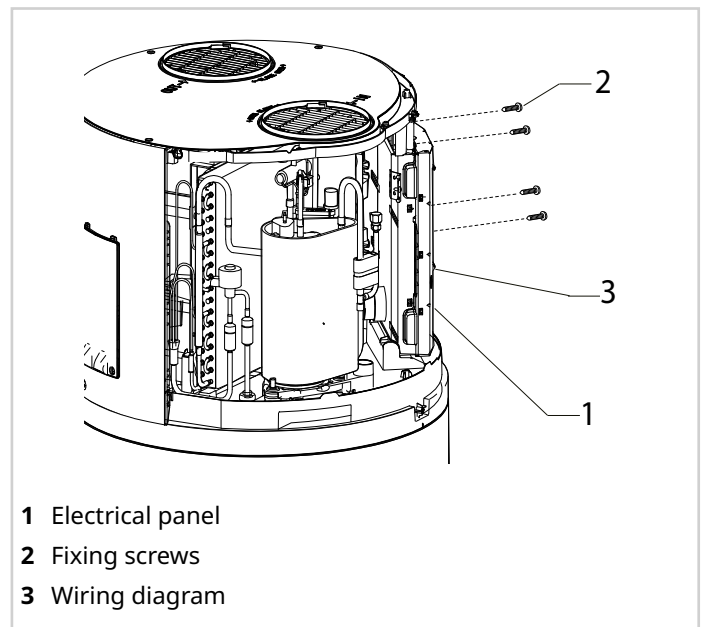

- ▶ unscrew the fixing screws
- ▶ remove the electrical panel access panel



- 1 Electrical panel
- 2 Fixing screws
- 3 Wiring diagram

6. Water connections

6.1 Prerequisites

-  This section is intended exclusively for the Installer.
-  Refer to the Technical data chapter for details.
-  Follow the safety instructions in the “About R-290 refrigerant” chapter
-  The hydraulic system and its components must be designed by a qualified technician who must work according to the rules of good practice and national regulations.
-  **Check that:**
 - the maximum water pressure and temperature are compatible with the operating limits of the unit
 - discharge shut-off valves are installed at the lowest points of the system so that the circuit can be completely drained during maintenance
 - air vents are installed at the highest points of the system, in easily accessible places
 - the unit is only connected to closed hydraulic circuits.

6.2 Water characteristics

The quality of the water used must be in accordance with the requirements in the following table, otherwise a treatment system must be provided.

Water characteristics for copper corrosion limit	
PH (25°C)	7,5 ÷ 9,0
SO ₄ ⁻	< 100
HCO ₃ ⁻ / SO ₄ ⁻	> 1
Total hardness	8 ÷ 15 °f (4.5-8.5 dH)
Cl ⁻	< 50 ppm
PO ₄ ³⁻	< 2,0 ppm
NH ₃	< 0,5 ppm
Free Chlorine	< 0,5 ppm
Fe ₃ ⁺	< 0,5 ppm
Mn ⁺⁺	< 0,05 ppm
CO ₂	< 50 ppm
H ₂ S	< 50 ppm
Temperature	< 80 °C
Oxygen content	< 0,1 ppm

Sand	10 mg/L 0.1 to 0.7 mm max diameter
Ferric hydroxide Fe ₃ O ₄ (black)	Dose < 7.5 mg/L 50% mass with diameter < 10 µm
Iron oxide Fe ₂ O ₃ (red)	Dose < 7.5 mg/L - Diameter < 1 µm





6.3 Cleaning

Before connecting the unit to the system:

- clean the system thoroughly with specific products to remove residues or impurities that could affect operation.
-  The warranty does not cover damage caused by limescale build-up, deposits and impurities in the water and/or failure of the hydraulic circuit cleaning system.

Existing systems

If a new unit is installed in an existing system:

- the system must be flushed thoroughly to eliminate any particles, sludge and waste.
-  The system must be cleaned before installing the new unit.
-  Dirt can be removed only with a suitable water flow rate.
-  Each section must be cleaned separately.
-  Pay particular attention to “blind spots”, where a lot of dirt can accumulate due to the reduced flow-rate.
-  If necessary, install an additional filter sized according to the type of pollutant to be removed.

6.4 Piping insulation

Isolate the entire hydraulic circuit, including all components to avoid:

- water pipes from freezing in winter.

6.5 Position of connections

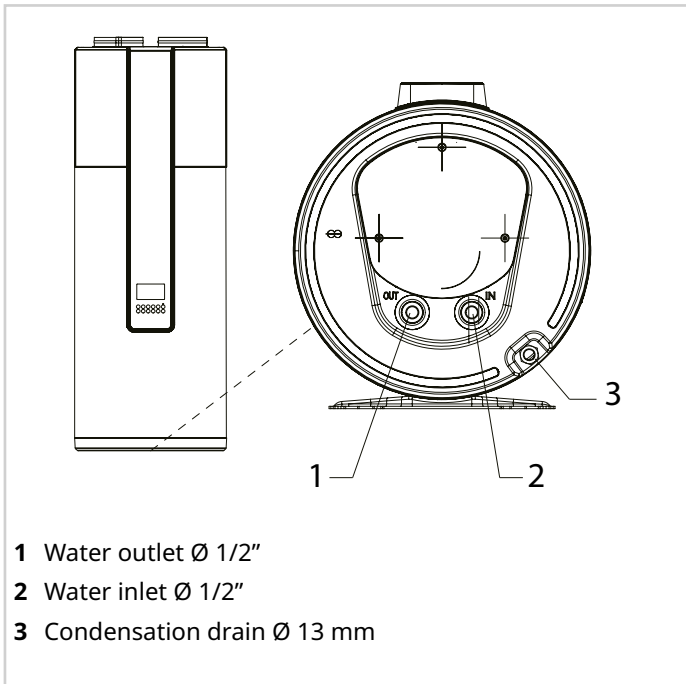

6.6 Hydraulic connection

Ensure that:

- use clean pipes free of dirt or dust
 - the end of the pipe is kept downwards when removing burrs
 - the end of the pipe is covered when passing it through a wall to prevent dust and dirt from entering
 - thread sealant is used to seal the connections that must withstand the pressures and temperatures of the circuit
 - the two types of materials are isolated from each other to prevent galvanic corrosion when using non-copper metal piping
 - the piping is not deformed by using excessive force or unsuitable tools during connection: this could cause the unit to malfunction.
- ⊖ Do not use materials that do not withstand high temperatures.
- ⚠ Always use the wrench and counter wrench method in tightening operations.

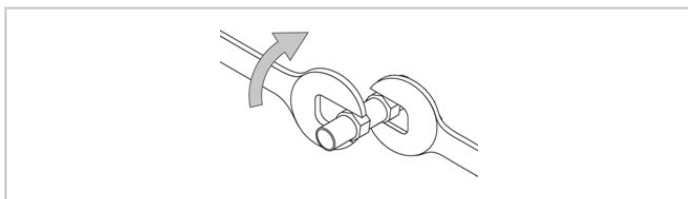

6.7 Water filter

Provided by the customer

- ⚠ Installation of the filter is mandatory.
- ⚠ Operation without a filter can cause irreversible damage to the unit.
- ⚠ Operation without a filter will void the warranty.

Remember that the filter must be:

- installed immediately at inlet to the water supply system
- easily accessible

- ⚠ Periodically
- ⊖ The filter should be removed.

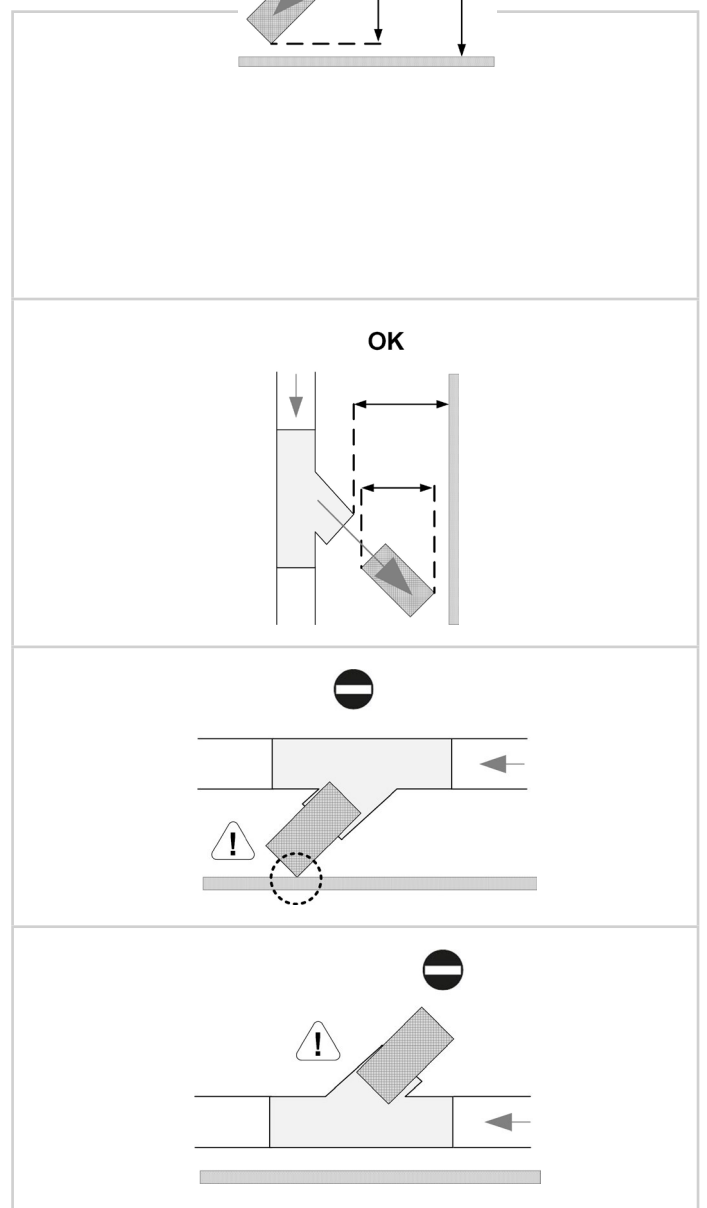

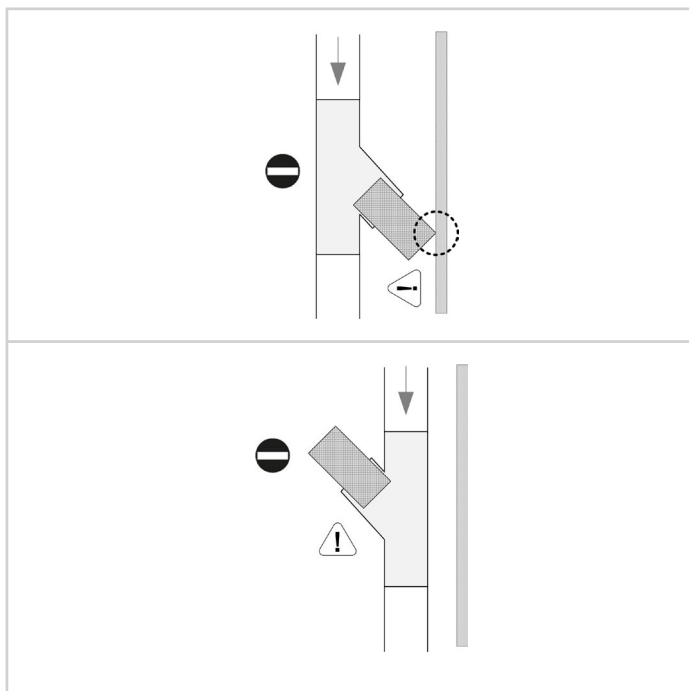

6.8 Pressure reducing valve

Provided by the customer

If the water inlet pressure is lower than 0.2 MPa (2 bar), a pump should be installed on the water inlet line.

- ⚠ If the water supply pressure is higher than 0.65 MPa (6.5 bar), a pressure reducer should be installed on the water inlet to ensure the safety of the water tank.
- ⚠ A calibration pressure between 3-4 bar (0.3-0.4 MPa) is recommended. Check the pressure periodically.

6.9 Filling the water tank

- ⚠ Fill the water tank (DHW) only during unit start-up. If the home is not immediately lived in or the unit is turned off for long periods, empty the water tank to avoid water stagnation, or with temperatures close to 0°C the risk of frost.

Once the hydraulic connections have been completed, the DHW tank can be filled.

Before charging:

- ▶ turn the system's main switch off
- ▶ check that the system shut-off valve is closed

To fill the water tank:

- ▶ start filling, slowly opening the water shut-off valve and water supply system inlet
- ▶ open the hot water taps (bathroom and kitchen)

- ⚠ Operations without water in the water tank could damage the electric heater. The manufacturer will not be liable for any damage caused by this problem.

6.10 Expansion tank

Provided by the customer

The expansion vessel maintains the correct system pressure as the water temperature changes, to compensate for pressure variations and/or water hammering in the cold water network and to prevent water leaks.

Provide an expansion vessel suited to the size of the unit (it is advisable to have this calculated by a heating engineer).

6.11 Pressure relief valve

Provided by the customer

- ⚠ Install the pressure relief valve (max 7.5 Bar) (max 0.75 MPa) at the cold water inlet and connect it to a suitable drain, otherwise if the valve trips and floods the rooms, the heat pump manufacturer will not be liable.
- ⚠ The drain pipe connected to the pressure relief valve must be installed in a continuous downward direction to a suitable drain and protected from frost.
- ⚠ The pressure relief valve must be regularly operated to remove lime deposits and to ensure that it is not blocked.

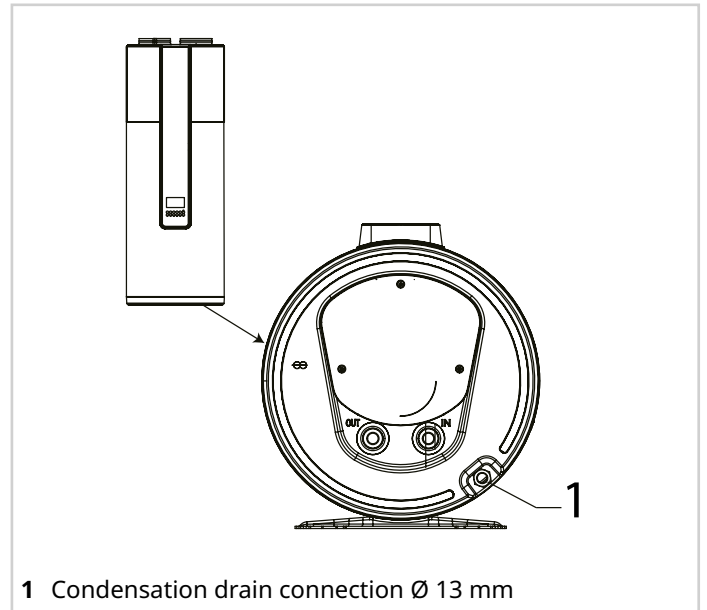
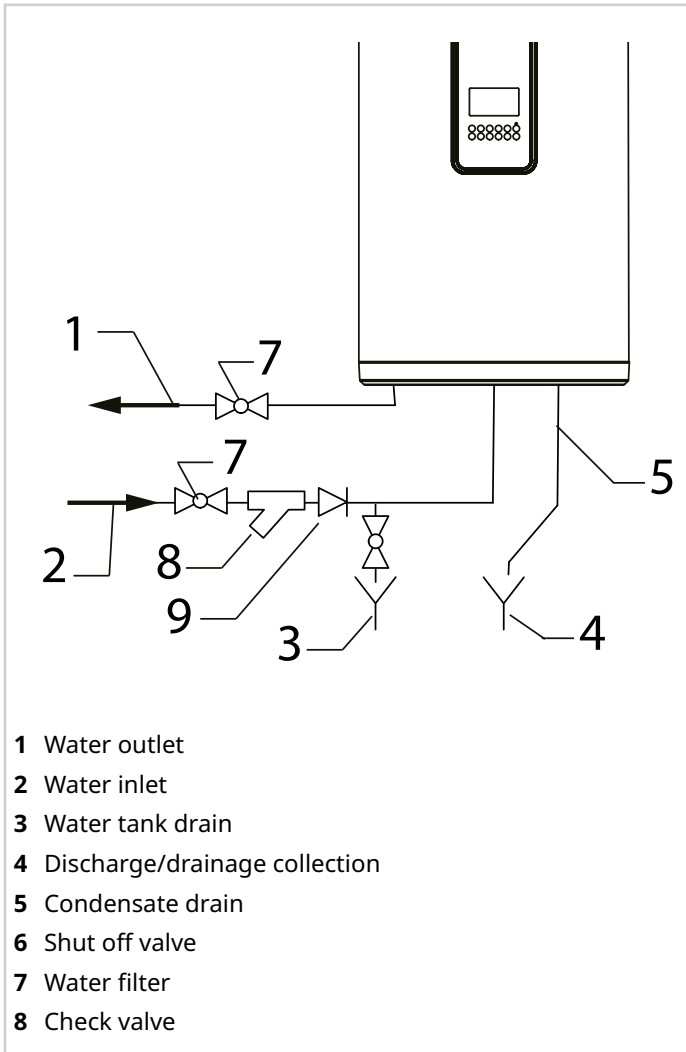

Drain pan under the unit

Not supplied.

Condensation can leak out of the unit if the drainage pipe is obstructed.

Consider installing a drain pan.

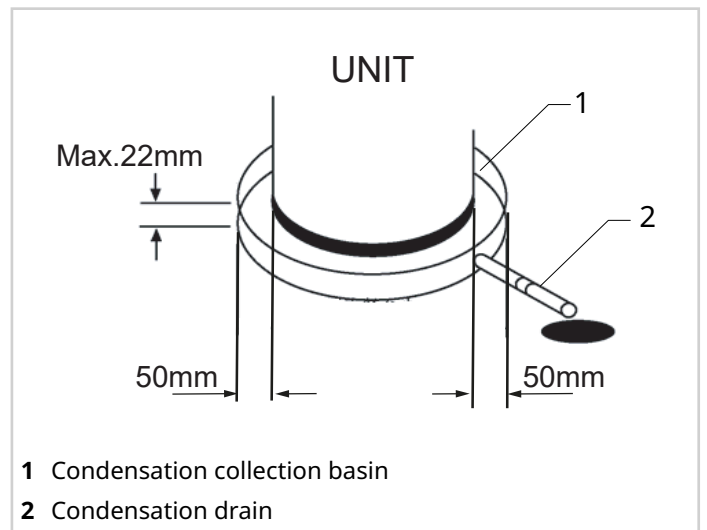

Pressure relief valve connection

- ▶ connect the pipe to the pressure relief valve
- ▶ direct the exhaust pipe towards a suitable drain

6.12 Condensate drain

The condensate must be disposed of in order to avoid damage to people and property.

Check that:

- ▶ The condensate drain pipe must be installed and routed to a discharge/drainage collection.

⚠ Incorrect drainage can cause water to seep into the building, furniture, etc.

Condensation drain connection

- ▶ connect the pipe to the condensation drain
- ▶ direct the pipe towards a suitable drain

7. Aeraulic connections

7.1 Prerequisites

- ⚠ This section is intended exclusively for the Installer.
- ⚠ The aeraulic system and its components must be designed by a qualified technician who shall work according to the rules of good practice and national regulations.
- ⚠ Operate in compliance with safety regulations in force.
- ⚠ The sizing and correct execution of the aeraulic connections are essential to ensure smooth operation of the unit and an adequate level of silence in the room.
- ⚠ Pressure drops in the ducting will decrease the air flow-rate, which can lead to a reduction in unit efficiency

⚠ Check that:

- the ducts have a section that is larger (or equal to, but never smaller) than the unit's suction inlet and supply
- the weight of the channels must not burden on the connection flanges
- anti-vibration joints are placed between the ducts and unit
- connection to the flanges and between the various sections of the channels must guarantee air seal, avoiding dispersions penalising the overall efficiency of the system
- pressure drops are limited by optimising the circuit, type and number of bends and branches
- wide-radius bends are used
- with air exhaust of the ducted unit, when the heat pump is in operation, condensation can form outside the ducts.

- ⚠ Thermally insulate the channels on the delivery line to prevent heat losses and condensation.

7.2 Unit fittings

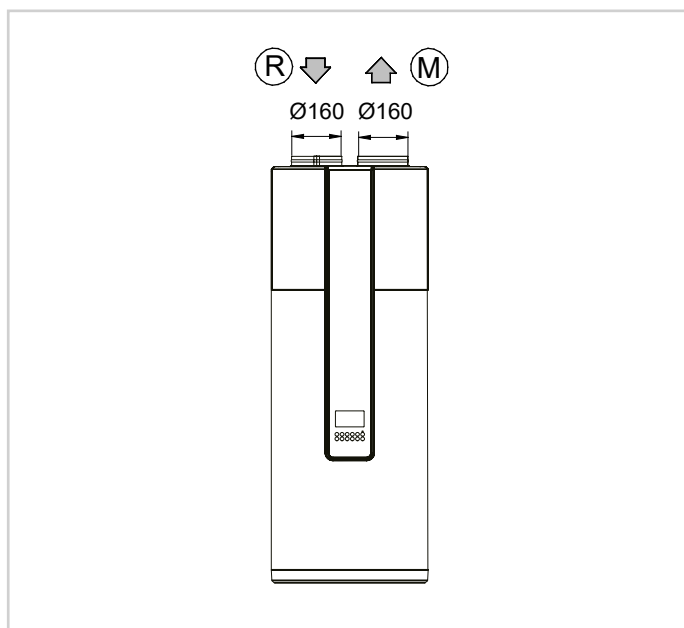

R	Outdoor air return
M	Air supply

7.3 Position of air ducts

Duct length

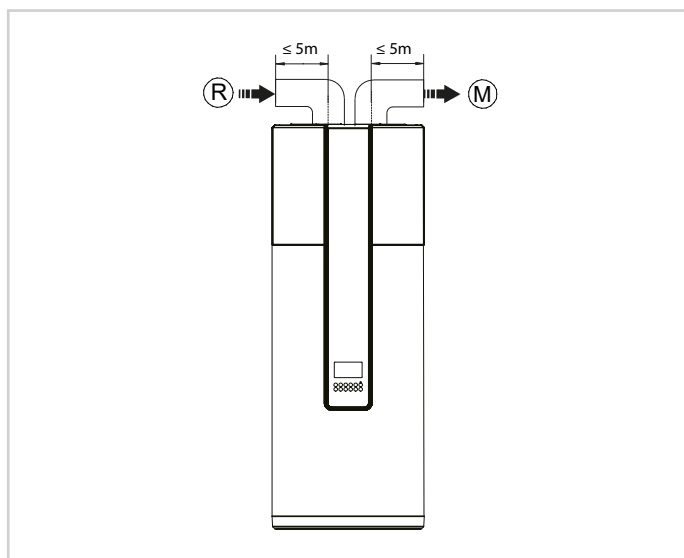

Outdoor air return

Position in an area with a low concentration of impurities (dust, odours, exhaust gases, etc.).

Exhaust outlet

Away from terraces, balconies, neighbouring properties. Avoid upwind areas

Avoid recirculation of exhaust/return air.

Provide 90° bends directed downwards.

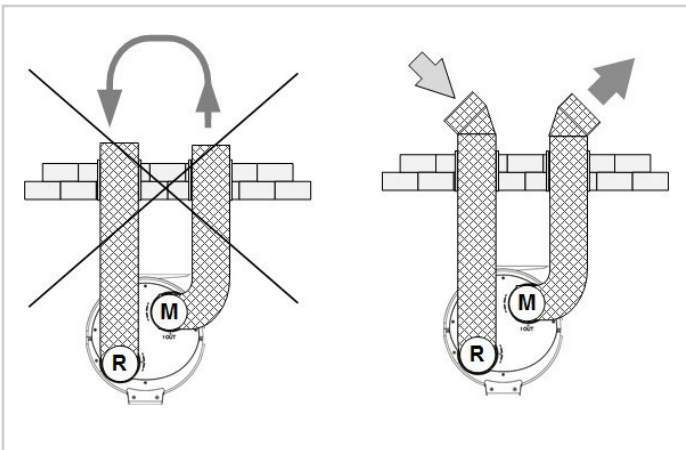

Minimum spacing 800 mm

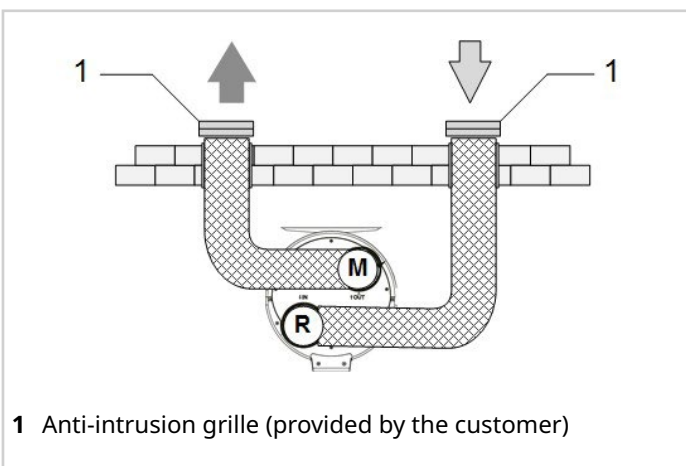
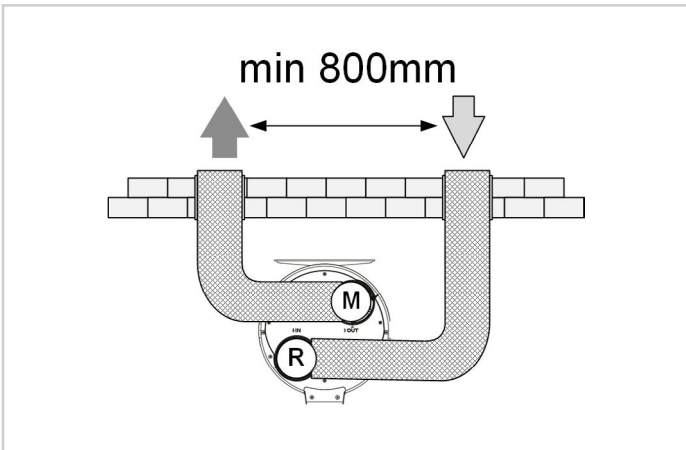

1 Anti-intrusion grille (provided by the customer)

Anti-intrusion grille (provided by the customer)



Check that:

- the unit is connected with ducts that go outside; the ducts must be protected from water to prevent water entering the unit

⚠ Should water enter the unit, components could get damaged and cause failure.

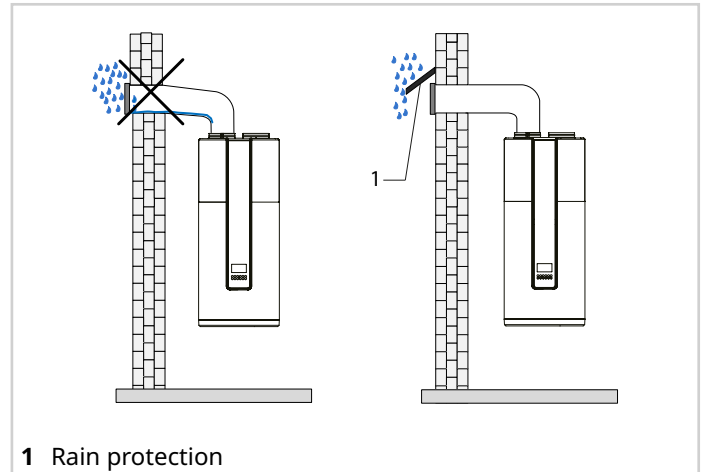

1 Rain protection

⚠ The ducts must not be sloping down to the unit to prevent condensation or water from returning.

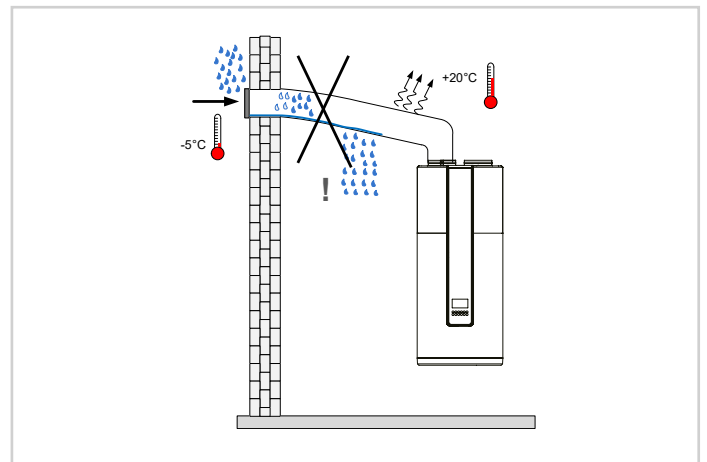

Duct insulation

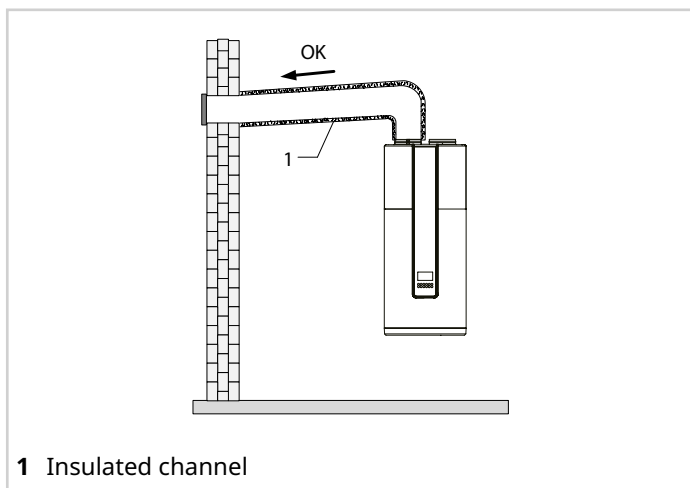

7.4 Grille to prevent small animals or leaves from entering inside

Provided by the customer



Unit inlet installation.

In the case of ducting, the integration of a grille in the air inlet piping is required.

The grille should be provided on the outdoor air suction inlet or on the duct in an easily accessible position for routine maintenance, the mesh size should be about 1.2 mm.

Grille position

Without ducting

- Install on the suction inlet.

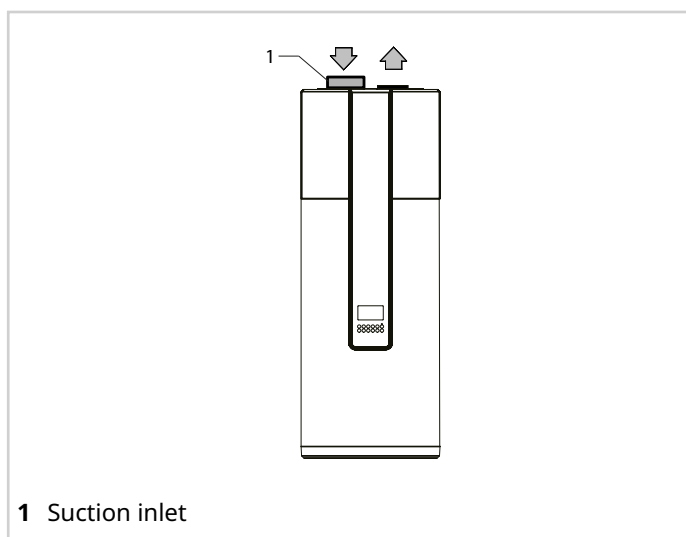

With ducting

- Install on the suction duct.

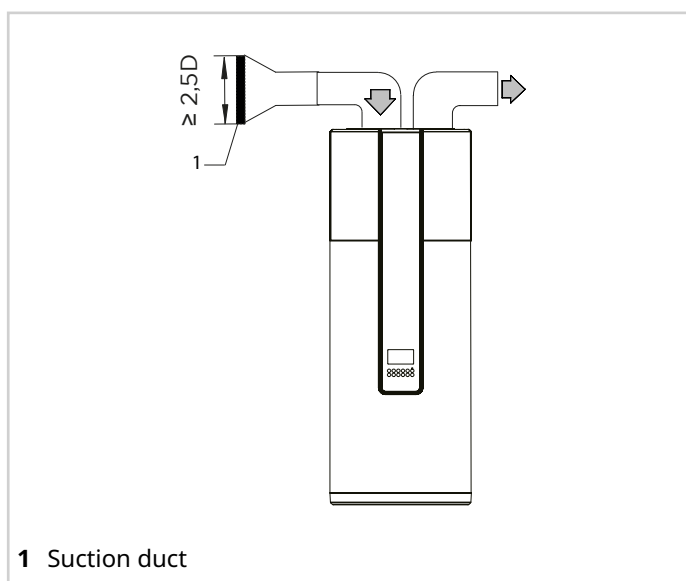

8. Electrical connections

8.1 Prerequisites

- ⚠ This section is intended exclusively for the Installer.
- ⚠ The electrical system and its components must be designed by a qualified technician who must work according to the rules of good practice and national regulations.
- ⚠ All electrical operations should be performed by trained personnel having the necessary requirements by the regulations in force and being informed about the risks relevant to these activities.
- ⚠ Operate in compliance with safety regulations in force.
- ⚠ The power cables and the protection cable section must be defined in accordance with the characteristics of the protections adopted.
- ⚠ The protection devices of the unit power line must be able to stop the presumed short circuit current, whose value must be determined in function of system features.
- ⚠ Refer to the unit electrical diagram (the number of the diagram is shown on the serial number label).
- ⚠ Check that the mains power supply complies with the data on the serial number plate.
- ⚠ Before starting work, verify that the sectioning device at the start of the unit power line is open, blocked and equipped with cartel warning.
- ⚠ The supply line must be disconnectable from the rest of the building's power mains with an all-pole magnetothermic circuit breaker with separation of contacts on all poles, to be implemented in accordance with current laws and regulations.
- ⚠ The protection must be sized in accordance with the electrical data declared by the manufacturer.
- ⚠ Disconnect the power supply before making any connection.
- ⚠ Do not crush cable bundles and prevent them from coming into contact with piping and any sharp edges.
- ⚠ Primarily you have to realize the earthing connection.
- ⚠ Incorrect grounding may cause electric shocks.
- ⚠ All external high voltage loads, if connected to a metal fitting or grounding clip, must be earthed.
- ⚠ The current required for each external load must be less than 0.2 A. If the current required for a single load is greater than 0,2 A, insert a contactor for control.
- ⚠ Install an earth leakage breaker (30 mA).
- ⚠ Failure to observe this precaution may result in electric shocks.
- ⚠ Power and signal cables should be routed as separately as possible to avoid any interference.
- ⚠ Keep the unit's controller wiring as far away from hot surfaces as possible. It is advisable to use cables with cross-linked polyvinyl chloride sheath.
- ⚠ For the electrical connection, use a cable of sufficient length to cover the entire distance without any connection work. Do not use extension cords. Do not apply other loads on the power supply.
- ⚠ If the power cable is damaged, it must be replaced by qualified personnel and in accordance with current national regulations.

⚠ The manufacturer is not liable for any damage caused by failure to install a grounding system or failure to comply with the diagrams.

⚠ Check the voltage values which must be within the limits: 220-240V +/- 10%.

⚠ Before power the unit, make sure that all the protections that were removed during the electrical connection work have been restored.

⊖ It is forbidden to connect the earth wire to gas or water pipes, lightning rods or telephone ground.

8.2 Electrical connection

⚠ Before removing the protection panel from the electrical panel, disconnect the power supply to the indoor unit and to all the other electrically powered components.

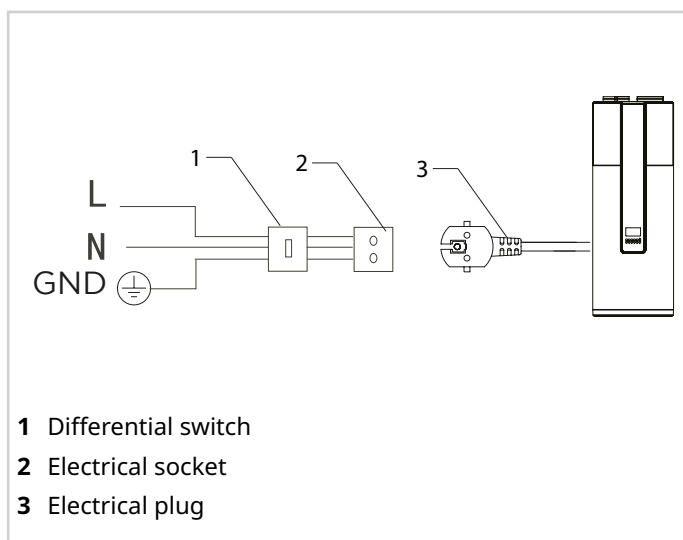

8.3 Connecting the power supply

⚠ Ensure that:

- an earth leakage breaker and a fuse or magnetothermic circuit breaker are connected to the supply line

⚠ To avoid machine failure and prevent a risk of fire, never use the power cable and fuse with an incorrect rated current.

⚠ The earth pole of the socket must be earthed correctly: check that the power socket and plug are dry and connected properly.

8.4 Electric cable sizes

Minimum cable section (mm ²)	≥1.5
Grounding wire	≥1.5

Recommended power cable type is H05RN-F.

8.5 Wiring diagram

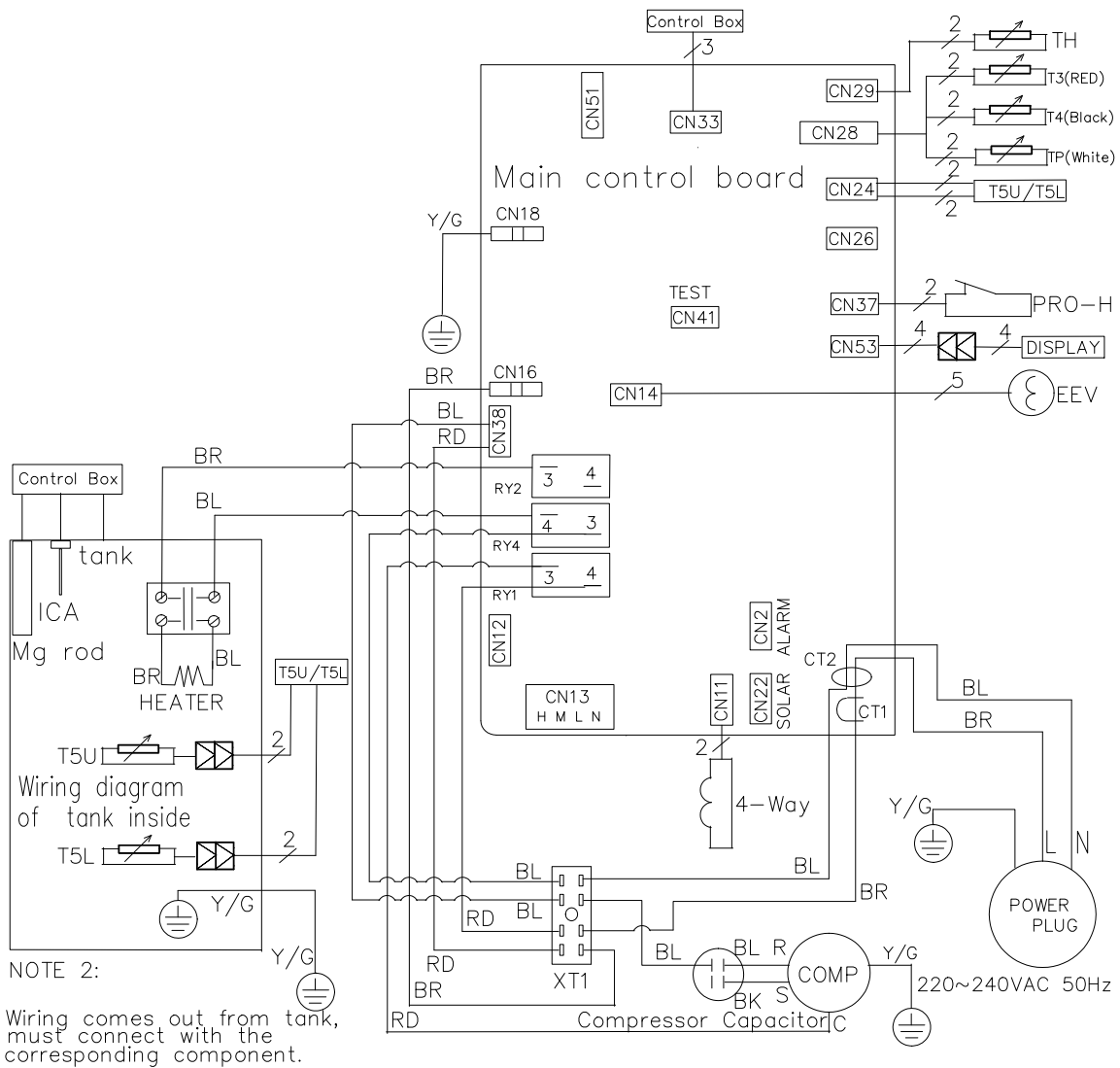

Sign	Description
CT1	Power transformer
CT2	Zero sequence power transformer
T3	Evaporator temp. sensor
T4	Outdoor temp. sensor
T5U	Water tank temp. sensor (high)
T5L	Water tank temp. sensor (low)
TP	Discharge temp. sensor
TH	Suction temp. sensor
EVV	Electronic expansion valve
XT1	Basic connections
ICA	Impressed current anode

9. Starting up the system

- ⚠ This section is intended only for the Technical Support Service.
- ⚠ The electrical and hydraulic connections and other works typical of the system are the responsibility of the Installer.
- ⚠ Operate in compliance with safety regulations in force.
- ⚠ Upon request, the service centres performing the start-up.
- ⚠ Agree upon in advance the start-up data with the service centre.
- ⚠ When installing or servicing, never leave the unit unattended after removing the service panels.
- ⚠ If the unit was tilted during transport, wait at least 2 hours before start-up.
- ⚠ **Check that:**
 - the unit should be installed properly and in conformity with this manual
 - the electrical power supply line should be isolated at the beginning
 - the unit isolator is open, locked and equipped with the suitable warning
 - the unit is not powered.

Remember that:

- during installation, unit settings and parameters should be configured by the Installer according to the installation configuration, climatic conditions, and end-user preferences
- the relevant settings are accessible and programmable through the user interface.

i Refer to the keyboard manual for operation.

⚠ **Enable the automatic anti-legionella function as described in the installer section of the keypad manual.**

example, transport, handling or other).

⚠ Only use the pressure sockets if the refrigerant circuit needs to be charged or discharged.

9.1 Refrigeration circuit

Visually check the refrigerant circuit.

Check that:

- any oil stains may be a sign of leaks (caused by, for

9.2 Water circuit

Check that:

- before connecting the unit, the hydraulic system has been washed and the washing water has been drained
- the water circuit has been charged and pressurised
- the shut-off valves on the circuit are in the "OPEN" position.

 Check that there isn't air in the circuit, if required, evacuate it using the air bleed valve placed in the system high points.

9.3 Aeraulic circuit

Check that:

- the rooms are clean (no dirt)
- the ducting is completed, connected and free from obstructions.

 Excessive dust and lint can affect operation of the unit, making it necessary to clean the filters more often.

9.4 Electric circuit

Verify that the unit is connected to the ground plant.

Check tightening of the conductors:

- vibrations caused by handling and transport might cause them to come loose.

Connect the unit by closing the sectioning device, but leave it on OFF.

Check the network voltage and frequency values, which must be within the limits:

- 220/240V +/- 10%
- 50 Hz +/- 1%

 Operating outside the limits can cause damages or malfunctions and voids the warranty.

9.5 Check voltages - Consumptions

Check that the air temperatures are within the operating limits.

With the unit operating at steady state, i.e. in stable and close to working condition.

Check:

- power supply voltage
- total absorption of the unit
- absorption of the single electric loads.

Power socket

Check that:

- the power supply is switched on and the unit is left running for half an hour
- the power supply is switched off, the plug is disconnected and the socket and plug have not overheated.

9.6 TCO operation (temperature switch)

The compressor and electric heater power supply is automatically provided by the TCO temperature switch. If the water temperature is higher than 85°C, the TCO switch automatically disconnects the power supply to the compressor and heater; this will have to be reset manually.

9.7 Preliminary checks

i For details refer to the different manual sections.

⚠ Before starting the unit, ensure that there is no dust or debris in the ambient and the ducting is free from obstructions.

Unit power supply: OFF

1	Installed unit. The wall and/or floor are capable of bearing the weight of the unit charged with water (see dimensions), in an upright position and protected from frost.
2	Installation site free from corrosive elements in the air such as sulphur, fluorine, chlorine and excessive dust.
3	Sufficient air flow-rate for operation of the unit: <ul style="list-style-type: none"> the unit must be placed in a space >15m³ and the airflow must not be obstructed the unit must not be placed in any kind of store cupboard or small compartment.
4	Sufficient space for unit maintenance.
5	Piping correctly fitted and free from leaks.
6	Inlet water filter from water supply system present and accessible for maintenance.
7	Condensation drain pipe connected and routed to a suitable drain, protected from frost.
8	DHW pressure relief valve drain pipe connected and routed to a suitable drain, protected from frost.
9	Temperature mixing valve or mixer (recommended) installed according to the manufacturer's instructions.
10	Hydraulic system charged, pressurised and vented.
11	Sufficient water inlet pressure, between 1.5 Bar to approx. 6.5 Bar (0.15 MPa to approx. 0.65 MPa) (≥1.5 Bar) (≥0.15 MPa)
12	The unit and electrical system are provided with a suitable grounding connection.
13	An overload protection fuse / differential circuit-breaker are present.
14	Power and controller wiring compliant with national standards and the requirements in this manual
15	Power supply voltage within the limits: 220-240V +/- 10%.
16	Outdoor air temperature within the limits: higher than -7°C and lower than 43°C. If the outdoor air temperature is outside these limits, the electric heaters are activated to fulfil the hot water request.
17	Is the pressure relief valve present? Is the setting correct?

Checks after installation

1	Understand how to use the user interface module to set the various modes and functions.
2	Periodically check the condensation drain pan and piping
3	Water leakage from the plastic protection indicates a possible blockage of the condensation drain pipe, so it must be cleaned.
4	For optimal operation, remove and clean the air filter.

10. Start-up

10.1 Start-up report

Identifying the operating objective conditions is useful to control the unit over time.

With the unit at steady state, i.e. in stable and close to working conditions, collect the following data:

- total voltages and absorptions with unit at full load
- absorptions of the different electric loads (compressors, fans, pumps etc)
- temperatures and flows of the different fluids (water, air) both in input and in output from the unit
- temperature and pressures on the characteristic points of the refrigerating circuit (compressor discharge, liquid, intake)

The measurements must be kept and made available during maintenance interventions.

10.2 2014/68/UE PED directive

DIRECTIVE 2014/68/UE PED gives instructions for installers, users and maintenance technicians as well.

Refer to local implementing regulations; briefly and for information only.

Compulsory verification of the first installation:



- only for units assembled on the installer's building site (for ex. Condensing circuit + direct expansion unit)
- Certification of setting in service:
- for all the units

Periodical verifications:

- to be executed with the frequency indicated by the Manufacturer (see the "maintenance inspections" paragraph)

11. Maintenance



11.1 Prerequisites

-  This section is intended only for the Technical Support Service.
-  All operations must be carried out by personnel who meet the requirements of current regulations and are trained in the risks related to such operations.
-  Operate in compliance with safety regulations in force.

The maintenance allows to:

- maintaining the unit efficient
- reduce the deterioration speed all the equipment is subject to over time
- assemble information and data to understand the unit's efficiency status and prevent possible failures.

Check that:

- the electrical power supply line should be isolated at the beginning
 - the unit isolator is open, locked and equipped with the suitable warning
 - the unit is not powered.
-  After turning off the power, wait at least 5 minutes before accessing to the electrical panel or any other electrical component.
-  Before accessing check with a multimeter that there are no residual voltage.
-  When installing or servicing, never leave the unit unattended after removing the service panels.

11.2 Maintenance check list

Intervention frequency (months)		1	6	12
1	Air filter (inlet/outlet)	X		
2	Internal water tank		X	
3	Electric heater		X	
4	Safety valve			X-a
5	Water filter			X-a
6	Expansion vessel			X-a
7	Check leaks*			X
8	Magnesium anode ⁽¹⁾		X	

i *Refer to the local regulations. Companies and technicians that carry out installation, maintenance/fixing, leak control and recovery interventions must be CERTIFIED as required by local regulations.

1 Maintenance of the magnesium anode is excluded when the unit is regularly supplied with power.

X-a = If not otherwise prescribed, refer to the instructions of the manufacturer and/or supplier of the product.

11.3 Unit booklet

It's advisable to create a unit booklet to take notes of the unit interventions.

In this way it will be easier to adequately note the various interventions and aid any troubleshooting.

Report on the booklet:

- date
- intervention description
- carried out measures etc.

11.4 Standby mode

In case of a long period of inactivity:

- ▶ turn off the power
- ▶ prevent the risk of freezing (empty the water tank)

11.5 Emptying the water tank

The unit is not fitted with a drain valve, so one must be provided on a pipe connecting to the system near to the device and below it.

- ⚠ All operations must be carried out with the unit shut down and disconnected from the mains power supply.
- ⚠ Clean the internal water tank and electric heater to keep the unit performing efficiently.

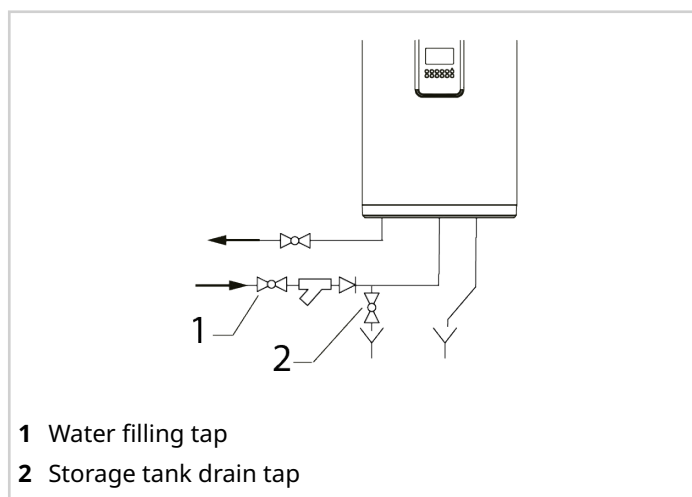

Before emptying:

- ▶ check that the water drain tap is closed

To drain the water tank:

- ▶ open the water tank drain tap
- ▶ open the hot and cold water taps

- ⚠ Beware of possible burns.

- ⚠ The outlet water temperature can be very hot while emptying the tank.

11.6 Cleaning the outer coating

To clean:

- ▶ soapy water
- ▶ water-based detergents containing anionic and/or non-ionic surfactants

Always rinse with clean water.

- ⚠ Do not use solvent-based degreasing agents such as: acetone, denatured ethyl alcohol, trichloroethylene, white spirit, etc.
- ⚠ Do not use dilute acids in aqueous solution (Hydrochloric Acid, Nitric Acid) and products containing dilute acids.
- ⚠ Do not use dilute bases in aqueous solution (Caustic Soda, Sodium Hypochlorite, Ammonia).
- ⚠ Do not use fluorinated hydrocarbons.
- ⚠ Do not use mineral-based lubricating oils.
- ⓘ These substances can attack the surface of the product and lead to the formation of cracks and, over time, to the possibility of breakage of the plastic material.

11.7 Power supply

- ▶ check that the connections between the power plug and socket and grounding are correct

11.8 Water filter

- ▶ check and clean the water filter

In case of obstruction:

- ▶ clean the filter

11.9 Expansion vessel

- ▶ check the expansion vessel charge
- ▶ check at least once a year

If you necessary load with nitrogen, take care that the pressure does not exceed the value indicated on the label.

11.10 DHW temperature

Set the water temperature lower to reduce heat dissipation, to prevent scaling and to save energy, if the amount of outlet water is sufficient.

11.11 Coil

The coil must allow maximum thermal exchange, therefore, the surface must be clear from dirt and scaling.

i Clean at least every six months.

To clean:

- ▶ use a soft brush, vacuum dirt exhauster or pressurised air jet
- ▶ clean the air inlet side
- ▶ keep the direction parallel to the flow of the flaps to avoid damages

⚠ Check that the aluminium fins are not bent or damaged, in the event of damages contact the authorised service centre which will “comb” the coil to restore optimal air flow

⚠ Accidental contact with the exchanger flaps can cause injuries from cut: use protective gloves.

11.12 Condensation collection basin

Dirt or scale can give rise to clogging. Also, microorganisms and mould can flourish in the bowl.

⚠ It is very important to foresee periodical cleaning with suitable detergents and, eventually, disinfect with sanitising products.

⚠ Once cleaning is completed, pour water inside the bowl to check the regular outflow.

11.13 Air filter

⚠ For hygiene reasons, it is extremely important to clean and replace the filters.

⚠ A clogged filter reduces unit performance and efficiency.

⚠ The frequency with which the filters must be checked depends on the outdoor air quality, the operating hours of the unit, and the dustiness and crowded areas of the rooms.

⚠ Frequency can indicatively vary from WEEKLY to MONTHLY.

It is advised to start with frequent checks, subsequently

adjusting the frequency to the degree of dirtying.

R	Air inlet
M	Air outlet

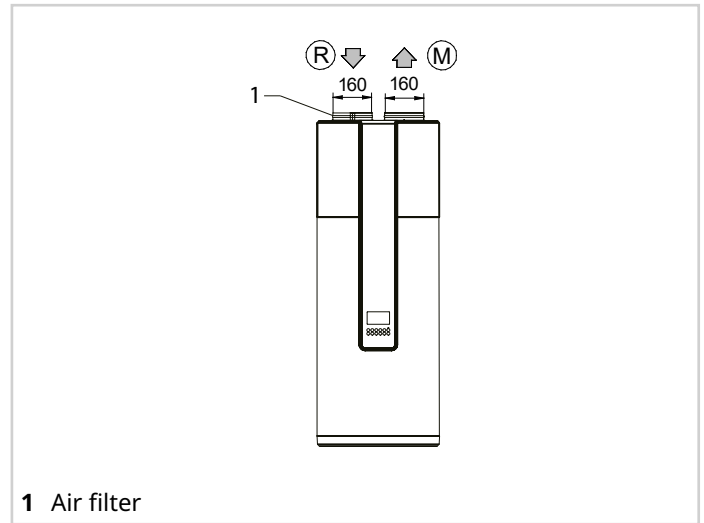

Remove the filter located directly above the air inlet (if the air inlet is without ducting).

To clean:

- ▶ unscrew the air intake loop
- ▶ pull the filter out
- ▶ clean the filter
- ▶ install the filter

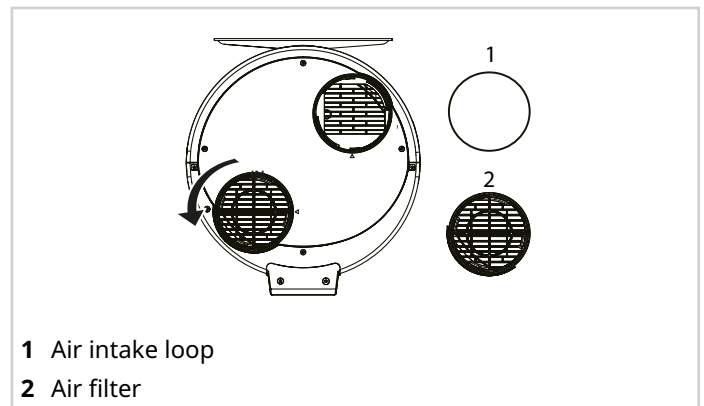

11.14 Anodes

The unit consists of 2 anodes:

- electronic anode
- magnesium anode

⚠ Powered unit: no magnesium anode control.

⚠ Non-powered unit: check the magnesium anode at the prescribed intervals.

Electronic anode

The unit is equipped with a dynamic system for the tank active protection from corrosion.

The anode is in active titanium.

i Periodical substitutions are not foreseen.

Magnesium anode

The magnesium sacrificial anodes assure the storage tank anticorrosive protection.

The magnesium anode is replaced when its diameter is $< 1/3$ of a third of the original anode.

⚠ All operations must be carried out with the unit shut down and disconnected from the power supply.

⚠ Empty the water tank before the operation.

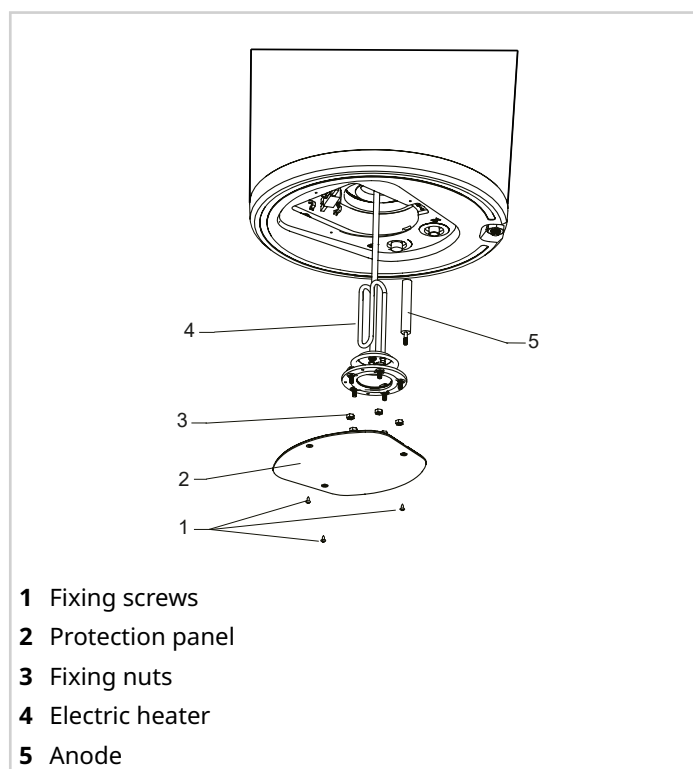

To remove the anode:

- ▶ unscrew the fixing screws
- ▶ remove the protection panel
- ▶ remove the cable from the resistor
- ▶ unscrew the fixing nuts
- ▶ pull out the resistor with the anode
- ▶ unscrew the anode
- ▶ replace it with a new one

Carry out the installation procedure in reverse order.

Check that:

- ▶ check that there are no water leaks
- ▶ open the water outlet tap until water flows out of the outlet tap, then close the tap

▶ turn on and restart the unit.

i Check its wear, replace if $\varnothing < 10-15\text{mm}$

The anode must be:

- checked every 6 to 12 months
- replaced every 2-3 years

11.15 Replacing or checking the heater

When replacing or checking the electric heater

⚠ All operations must be carried out with the unit shut down and disconnected from the power supply.

⚠ Empty the water tank before the operation.

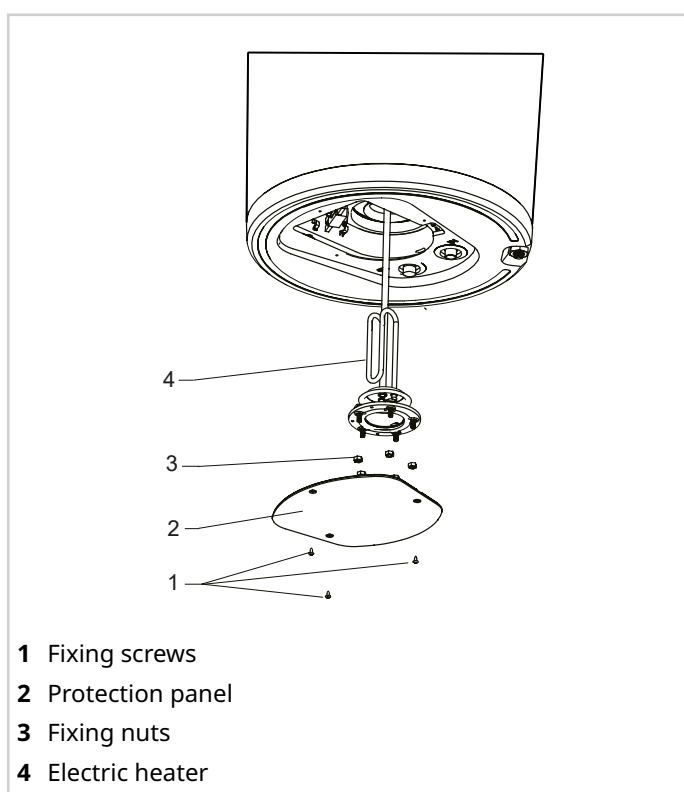

To remove the heater:

- ▶ unscrew the fixing screws
- ▶ remove the protection panel
- ▶ disconnect the heater power cable
- ▶ unscrew the fixing nuts
- ▶ pull the electric heater out.

Check that:

- ▶ there is no limescale on the heater
- ▶ if the heater fails, replace it.

Carry out the installation procedure in reverse order.

⚠ Check that there are no water leaks from

the fitting.

11.16 Resetting the electric E-heater

If the electric heater safety limiter trips, before resetting it, check that it has not been interrupted by an energy saving or scheduling operation.

Check whether the electric heater safety limiter is set at > 85°C or has tripped due to a fault.

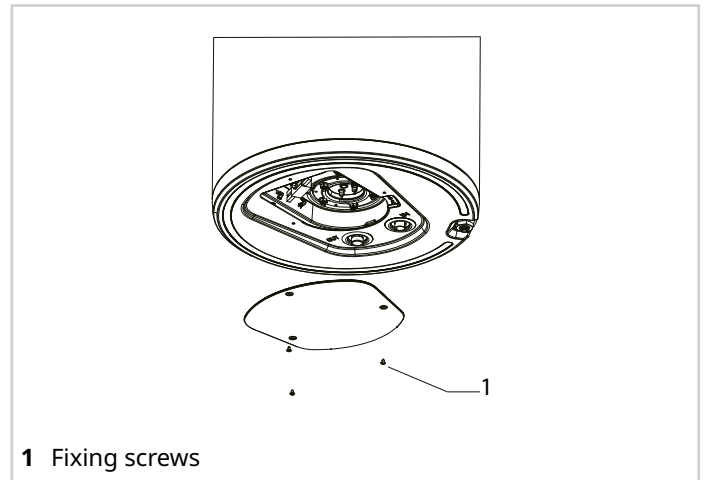

To access:

- ▶ undo the screws
- ▶ remove the cover

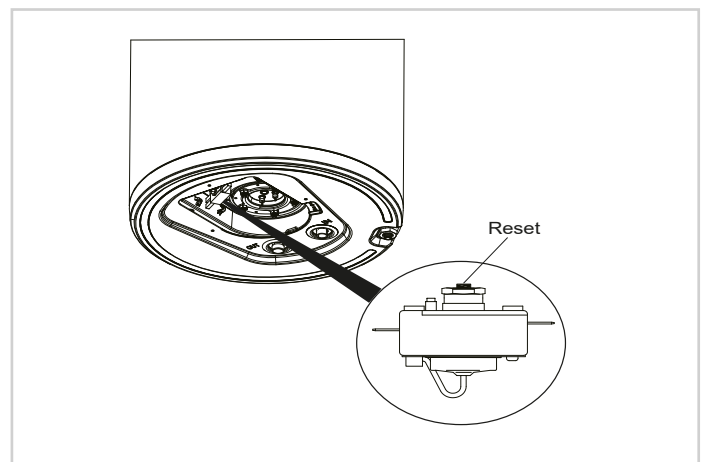

To reset the heater:

- ▶ press RESET

12. Decommissioning

12.1 Disconnection

⚠ Awaiting decommissioning and disposal, the unit can also be stored outdoors, as bad weather and rapid changes in temperature do not harm the environment provided that the electric, cooling and hydraulic circuits of the unit are intact and closed.

authorised personnel at existing collection centres.



12.1.1 WEEE INFORMATION

The manufacturer is registered on the EEE National Register, in compliance with implementation of Directive 2012/19/EU and relevant national regulations on waste electrical and electronic equipment.

This Directive requires electrical and electronic equipment to be disposed of properly.

Equipment bearing the crossed-out wheelie bin mark must be disposed of separately at the end of its life cycle to prevent damage to human health and to the environment. Electrical and electronic equipment must be disposed of together with all of its parts.

To dispose of "household" electrical and electronic equipment, the manufacturer recommends you contact an authorised dealer or an authorised ecological area.

"Professional" electrical and electronic equipment must be disposed of by authorised personnel through established waste disposal authorities around the country.

In this regard, here is the definition of household WEEE and professional WEEE:

WEEE from private households: WEEE originating from private households and WEEE which comes from commercial, industrial, institutional and other sources which, because of its nature and quantity, is similar to that from private households. Subject to the nature and quantity, where the waste from EEE was likely to have been by both a private household and users of other than private households, it will be classed as private household WEEE; Professional WEEE: all WEEE which comes from users other than private households.

This equipment may contain:

- refrigerant gas, the entire contents of which must be recovered in suitable containers by specialised personnel with the necessary qualifications;
- lubrication oil contained in compressors and in the cooling circuit to be collected;
- mixtures with antifreeze in the water circuit, the contents of which are to be collected;
- mechanical and electrical parts to be separated and disposed of as authorised.

When machine components to be replaced for maintenance purposes are removed or when the entire unit reaches the end of its life and needs to be removed from the installation, waste should be separated by its nature and disposed of by

13. Residual risks

13.1 General

In this section the most common situations are indicated, as these cannot be controlled by the manufacturer and could be a source of risk situations for people or things.

13.2 Danger zone

- This is an area in which only an authorised operator may work.
- The danger zone is the area inside the unit which is accessible only with the deliberate removal of protections or parts thereof.

13.3 Handling

- The handling operations, if implemented without all of the protection necessary and without due caution, may cause the drop or the tipping of the unit with the consequent damage, even serious, to persons, things or the unit itself.
- Handle the unit following the instructions provided in the present manual regarding the packaging and in compliance with the local regulations in force.
- Should the refrigerant leak please refer to the refrigerant "Safety sheet".

13.4 Installation

Remember that:

- incorrect installation of the unit can lead to water leaks, condensate accumulation, refrigerant leakage, electric shock, fire, malfunction or damage to the unit itself
- installation of the unit in a place where even infrequent flammable gas leaks are possible and the accumulation of these gases in the area around the unit can cause explosions and fires
- installation of the unit in a place that is not suitable to support its weight and/or provide adequate anchorage may cause it to fall and/or tip over, resulting in damage to property, people or the unit itself

Check:

- the location of the unit carefully
- that the installation is only carried out by qualified technical personnel and the instructions in this manual and current local regulations are followed
- the location of the unit carefully

 Easy access to the unit by children, unauthorised persons or animals may be the source of accidents, some serious.

 Install the unit in areas which are only accessible to authorised person and/or

provide protection against intrusion into the danger zone.

13.4.1 General risks

 Smell of burning, smoke or other signals of serious anomalies may indicate a situation which could cause damage to people, things or the unit itself.

In this case:

- electrically disconnect the unit
- contact the authorised service centre to identify and solve the problem causing the anomaly

 Accidental contact with exchange batteries, compressors, air delivery tubes or other components may cause injuries and/or burns.

 Always wear suitable clothing including protective gloves to work inside the danger zone.

 Maintenance and repair operations carried out by non-qualified personnel may cause damage to persons, things or the unit itself.

 Always contact the qualified assistance centre.

 Failing to close the unit panels or failure to check the correct tightening of all of the panelling fixing screws may cause damage to persons, things or the unit itself.

 Periodically check that all of the panels are correctly closed and fixed.

 If there is a fire the temperature of the refrigerant could reach values that increase the pressure to beyond the safety valve with the consequent possible projection of the refrigerant itself or explosion of the circuit parts that remain isolated by the closure of the tap.

 Do not remain in the vicinity of the safety valve and never leave the refrigerating

system taps closed.

13.4.2 Electric parts

- ⚠ An incomplete attachment line to the electric network or with incorrectly sized cables and/or unsuitable protective devices can cause electric shocks, intoxication, damage to the unit or fires.
- ⚠ Carry out all of the work on the electric system referring to the electric layout and the present manual ensuring the use of a system thereto dedicated.
- ⚠ An incorrect fixing of the electric components cover may lead to the entry of dust, water etc inside and may consequently electric shocks, damage to the unit or fires.
- ⚠ Always fix the unit cover properly.
- ⚠ When the metallic mass of the unit is under voltage and is not correctly connected to the earthing system it may be a source of electric shock and electrocution.
- ⚠ Always pay particular attention to the implementation of the earthing system connections.
- ⚠ Contact with parts under voltage accessible inside the unit after the removal of the guards can cause electric shocks, burns and electrocution.
- ⚠ Open and padlock the general isolator prior to removing the guards and signal work in progress with the appropriate sign.
- ⚠ Contact with parts that could be under voltage due to the start up of the unit may cause electric shocks, burns and electrocution.
- ⚠ When voltage is unnecessary for the circuit open the isolator on the attachment line of the unit itself, padlock it and display the appropriate warning sign.

13.4.3 Moving parts

- ⚠ Contact with the transmissions or with the fan aspiration can cause injuries.

Remember that:

- before accessing inside the unit, open the disconnecter switch on the unit connection line, padlock it and display the appropriate warning sign
- contact with fans can cause injury.
- before removing the protection grills or fans, open the disconnecter switch on the unit connection line, padlock it and display the appropriate warning sign.

13.5 Refrigerant

- ⚠ The intervention of the safety valve and the consequent expulsion of the gas refrigerant may cause injuries and intoxication.
- ⚠ Always wear suitable clothing including protective gloves and eyeglasses for operations inside the danger zone.
- ⚠ Should the refrigerant leak please refer to the refrigerant "Safety sheet".
- ⚠ Contact between open flames or heat sources with the refrigerant or the heating of the gas circuit under pressure (e.g. during welding operations) may cause explosions or fires.
- ⚠ Do not place any heat source inside the danger zone.
- ⚠ The maintenance or repair interventions which include welding must be carried out with the system off.

13.6 Hydraulic parts

- ⚠ Defects in tubing, the attachments or the removal parts may cause a leak or water projection with the consequent damages to people, things or shortcircuit the unit.

14. Technical data

Size	100L		
Capacity and efficiency			
Tout 15/12 °C (DB/WB), Tw,in 15 °C Tw,out 45°C	Heating capacity	kW	0,98
	Total power input	kW	0,26
	COP		3,80
Tout 43/26 °C (DB/WB), Tw,in 15 °C Tw,out 65°C	Heating capacity	kW	1,444
	Total power input	kW	0,396
	COP		3,65
Electric heater		kW	1,5
Standard power supply		V	1-220 240-50
DHW reheating time	1 h/min		3hrs / 29.5mins
DHW maximum temperature	6 °C		65 (70)
Sound pressure level (1m)	5 dB(A)		/
Sound power level (L _{WA})		dB(A)	54
ErP			
Clima Average Heat pumps Water Heater (2)	Generator energy class		A+
	Domestic hot water profile		M
	η_{wh}	%	111
	AEC annual consumption	kWh	463
	Daily consumption	kWh	2,435
Clima Warmer Heat pumps Water Heater (3)	COP EN 16147		2,61
	Domestic hot water profile		M
	η_{wh}	%	114
	AEC annual consumption	kWh	451
	Daily consumption	kWh	2,133
Clima Colder Heat pumps Water Heater (4)	COP EN 16147		2,74
	Domestic hot water profile		M
	η_{wh}	%	92
	AEC annual consumption	kWh	558
	Daily consumption	kWh	2,631
	COP EN 16147		2,22
Storage tank			
Domestic hot water storage volume			98
Storage tank material			Enamel
Insulating material			Cyclopentane
Heat loss	7 W/K		18,2
Maximum operating pressure		bar	8
Insulation thickness		mm	42
Refrigeration circuit			
Type of compressor			Rotary
Refrigerant gas			R290
Quantity of refrigerant		kg	0,15
GWP		t	3
Tonne of CO ₂ equivalent *			0,00045
Oil quantity		ml	140
Expansion valve type			Electric expansion valve
Fan			
Type of fan			Centrifugal Fan
Airflow		m ³ /h	200
Available pressure		Pa	0-60
Integration			
Integration coil surface		m ²	0,41
Integration coil material			Hydrophilic aluminum Φ 5 Inner groove copper tube
Maximum operating pressure		bar	30/12

1. Inlet water temperature 15°C, storage set 45°C, source air 15°C D.B/12°C W.B.

2. The product conforms with the European ErP Directives, which include Commission Delegated Regulation (EU) no. 812/2013, Commission Delegated Regulation no. 814/2013, Clima Average, Heat Pump Water Heater

14.1 Dimensional

DSDH-P AQ 1 S 100

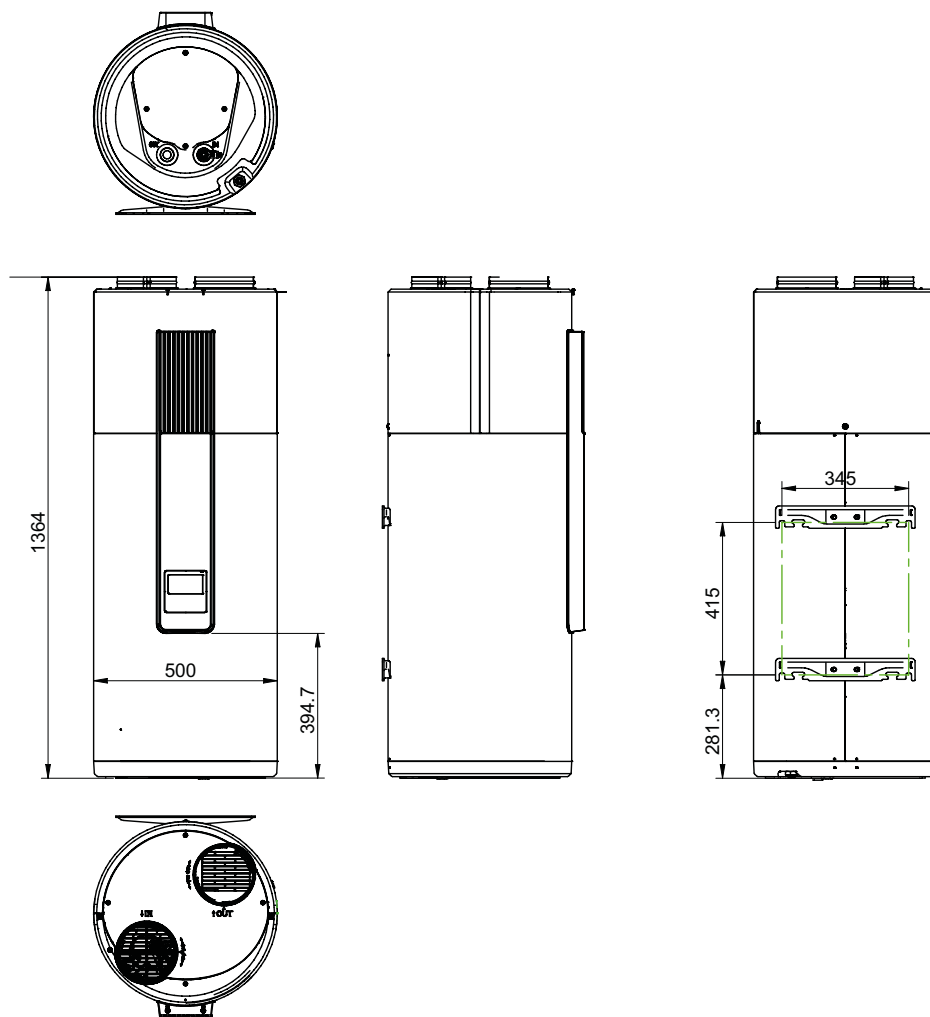

1. Compressor compartment
2. Electrical panel
3. Unit keypad
4. Power input
5. Condensate drain
6. Functional spaces
7. Anode
8. Water inlet 3/4" F
9. Water outlet 3/4" F

(R) Air return

(M) Air supply

WEIGHT DISTRIBUTION

Operating weight	Kg	160
Shipping weight	Kg	68

The presence of optional accessories may result in significant variation of the weights indicated



CLIVET DECLARATION OF CONFORMITY EU

DICHIARAZIONE DI CONFORMITÀ UE
KONFORMITÄTSEKTLÄRUNG EU
DECLARATION DE CONFORMITE EU
DECLARACIÓN DE CONFORMIDAD EU

WE DECLARE UNDER OUR SOLE RESPONSIBILITY THAT THE MACHINE

DICHIARIAMO SOTTO LA NOSTRA SOLA RESPONSABILITÀ CHE LA MACCHINA
WIR ERKLÄREN EIGENVERANTWORTLICH, DASS DIE MASCHINE
NOUS DÉCLARONS SOUS NOTRE SEULE RESPONSABILITÉ QUE LA MACHINE
EL FABRICANTE DECLARA BAJO SU EXCLUSIVA RESPONSABILIDAD QUE LA MÁQUINA

CATEGORY	HEAT PUMP – domestic hot water production
CATEGORIA	POMPA DI CALORE – produzione acqua calda sanitaria
KATEGORIE	WÄRMEPUMPE - warmwasserproduktion
CATEGORIE	POMPE À CHALEUR – production eau chaude sanitaire
CATEGORIA	BOMBA DE CALOR – producción de agua calientesanitaria

TYPE / TIPO / TYP / TYPE / TIPO

DSDH-P AQ 1 S 100

- **COMPLIES WITH THE FOLLOWING EC DIRECTIVES, INCLUDING THE MOST RECENT AMENDMENTS, AND THE RELEVANT NATIONAL HARMONISATION LEGISLATION CURRENTLY IN FORCE:**
- RISULTA IN CONFORMITÀ CON QUANTO PREVISTO DALLE SEGUENTI DIRETTIVE CE, COMPRESSE LE ULTIME MODIFICHE, E CON LA RELATIVA LEGISLAZIONE NAZIONALE DI RECEPIMENTO:
- DEN IN DEN FOLGENDEN EG-RICHTLINIEN VORGESEHENEN VORSCHRIFTEN, EINSCHLIEßLICH DER LETZTEN ÄNDERUNGEN, SOWIE DEN ANGEWANDTEN LANDESGESETZEN ENTSPRICHT:
- EST CONFORME AUX DIRECTIVES CE SUIVANTES, Y COMPRIS LES DERNIÈRES MODIFICATIONS, ET À LA LÉGISLATION NATIONALE D'ACCUEIL CORRESPONDANTE:
- ES CONFORME A LAS SIGUIENTES DIRECTIVAS CE, INCLUIDAS LAS ÚLTIMAS MODIFICACIONES, Y A LA RELATIVA LEGISLACIÓN NACIONAL DE RECEPCIÓN:

- 2014/35/UE** **Low voltage directive** / direttiva bassa tensione
Bestimmungen der Niederspannungsrichtlinie / directive basse tension
directiva de baja tensión
- 2014/30/UE** **Electromagnetic compatibility** / compatibilità elettromagnetica
Elektromagnetische Verträglichkeit / compatibilité électromagnétique
compatibilidad electromagnética
- 2014/53/UE** **Radio Equipment Directive** / Direttiva sulle apparecchiature radio
Richtlinie über Funkanlagen / Directive sur les équipements radio
Directiva sobre equipos radioeléctricos
- 2009/125/UE** **Ecodesign** / Progettazione ecocompatibile / Ecodesign / Éco-conception / Ecodiseño
- 2017/1369** **Ecolabeling** / Etichettatura energetica / Ecolabeling / Etiquetado energético / Étiquetage énergétique
- 2011/65/UE** **2015/863/UE** **RoHS**

-Unit manufactured and tested according to the followings Standards:
-Unità costruita e collaudata in conformità alle seguenti Normative:
-Unité construite et testée en conformité avec les Réglementations suivantes
-Unidad construida y probada de acuerdo con las siguientes Normativas
-Gebautes und geprüftes Gerät nach folgenden Normen

EN 300 328 V2.2.2 :2019 EN 62311 :2008 EN IEC 62311 :2020
EN 60335-1 :2012/A15 :2021 EN 60335-2-40 :2003/A13 :2012
EN 60335-2-21 :2021/A1 :2021 EN 62233 :2008 EN 62479 :2010
EN 50663 :2017 EN 301 489-1 V2.2.3 :2019 EN 301 489-17 V3.2.4 :2020
EN IEC 61000-3-2 :2019/A1 :2021 EN 61000-3-3 :2013/A2 :2021
EN IEC 55014-1 :2021 EN IEC 55014-2 :2021 REG. UE 814/2013
REG. UE 812/2013 EN 18031-1:2024 EN IEC 63000:2018

-Responsible to constitute the technical file is the company n°.00708410253 and registered at the Chamber of Commerce of Belluno Italy
-Responsabile a costituire il fascicolo tecnico è la società n° 00708410253 registrata presso la Camera di Commercio di Belluno Italia
-Verantwortliche für die technischen Unterlagen zusammenstellen n°.00708410253 ist das Unternehmen bei der Handelskammer von Belluno Italien registriert
-Responsable pour compiler le dossier technique est la société n°00708410253 enregistrée à la Chambre de Commerce de Belluno en Italie
-Encargado de elaborar el expediente técnico es la empresa n° 00708410253 registrada en la Cámara de Comercio de Belluno Italia

NAME / NOME / VORNAME / PRÉNOM / NOMBRE
SURNAME / COGNOME / ZUNAME / NOM / APELLIDOS

STEFANO
BELLO

FELTRE, 01/09/2025

COMPANY POSITION / POSIZIONE / BETRIEBSPOSITION / FONCTION / CARGO AMMINISTRATORE DELEGATO

3. The product conforms with the European ErP Directives, which include Commission Delegated Regulation (EU) no. 812/2013, Commission Delegated Regulation no. 814/2013, Clima Warmer, Heat Pump Water Heater
 4. The product conforms with the European ErP Directives, which include Commission Delegated Regulation (EU) no. 812/2013, Commission Delegated Regulation no. 814/2013, Clima Colder, Heat Pump Water Heater
 5. Data for fully ducted unit.
 6. Default value 65 °C, can be changed via Service mode to 70 °C
 7. Test conditions: average temperature 10 °C/OP20%.
- *Contains fluorinated greenhouse gases

Operating range

AQUA 100L

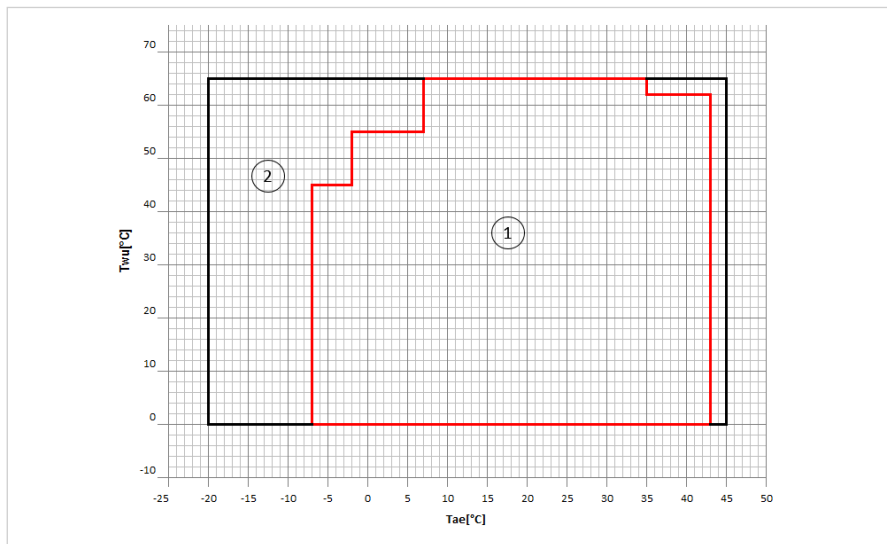

T_{wu} [°C] = storage water temperature

T_{ae} [°C] = heat exchanger inlet air temperature

1. Utilisation range of heat pump
2. Utilisation range of electric heater

FOR OVER 35 YEARS WE HAVE BEEN
OFFERING SOLUTIONS FOR SUSTAINABLE
COMFORT AND THE WELL-BEING OF PEOPLE
AND THE ENVIRONMENT

Info & Contacts: www.clivet.com

