

Uncased indoor unit for Hydro-Split heat pumps

EASYIN
HQCN-NEE 1 IC RANGE



TECHNICAL BULLETIN

DHW TANK

150 L

Page

3	Features and benefits
4	Standard unit technical specifications
5	Standard indoor unit components
6	Accessories separately supplied
10	Option compatibility
13	General technical data
22	Hydraulic connections
23	Electrical connections
24	System connections
30	Dimensional drawings

Features and benefits

EASYModules are specialized autonomous heat pump systems dedicated to meet the thermal and comfort requirements of single or multi-family homes with medium-low energy consumption. The system consists of a new generation monobloc outdoor unit, EDGE EVO 2.0 to R-32 and EDGE F to R-290, with very high efficiency that encloses the refrigerant circuit inside, this is combined with an internal hydraulic module available in four different versions as shown below.

EASYMINI

- Mini Version
- 50-litre domestic water tank
- Single-area water booster kit already included in standard unit
- Integrated inertial storage tank
- Built-in WiFi for connection to the dedicated APP
- Compact dimensions, suitable for replacing a boiler



EASYTANK

- Tower Version
- Two domestic water volumes 190 and 250 litres
- Integrated inertial storage tank
- Built-in WiFi for connection to the dedicated APP
- Integrated inertial storage tank



EASYBOX

- Box Version
- Integrated three-way valve for domestic hot water
- Compact dimensions
- Integrated inertial storage tank
- Built-in WiFi for connection to the dedicated APP



EASYIN

- Uncased version
- 150-litre domestic water tank can be expanded to 300 litres
- Compact dimensions for easy installation in walls
- Also available in the hybrid version with 24 kW or 34 kW boiler
- Integrated inertial storage tank
- Built-in WiFi for connection to the dedicated APP



Outdoor units that can be combined:

EDGE EVO 2.0

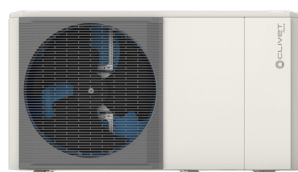

EDGE F

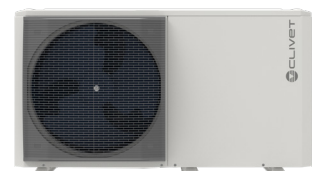

EASYIN - Indoor unit

Structure

Structure made of galvanised sheet metal with brackets for anchoring in the brickwork and frames on the edge of the structure to hide any imperfections. The frames are attached to the front panels and adjustable for greater flexibility with different installations.

Domestic hot water

- 150L domestic hot water storage tank in AISI 316 stainless steel, outer insulation in polyurethane (20 mm thick) and cover in black PVC
- Magnesium anode
- 2 kW safety and anti-legionella cycle electric heater
- Provision for domestic hot water recirculation circuit
- Probe well for solar thermal control
- 8-litre DHW side expansion tank
- 6 bar domestic hot water side pressure relief valve
- Anti-scalding thermostatic valve.

Water circuit

- 15-litre inertial tank
- Three-way switching valve for system or domestic water
- Magnetic dirt separator
- System relief valve
- 12-litre system expansion tank, 1 bar pre-charging

Electrical panel

The power section includes:

- main power supply terminals.

The control section includes:

- BMS management;
- daily and weekly switch-on/off scheduler and set point;
- anti-legionella function scheduling;
- two-area booster management;
- solar thermal management;
- management for backup heaters;
- interface terminal with graphic display.
- integrated wifi module for connection to the APP
- T5 temperature probe for temperature control in DHW tanks (3 m long and 6 mm bulb).

Standard unit kit

- Torx insert for opening and closing the unit's panels
- 1 quick coupling spring
- 1 expansion tank connection gasket
- 1 O-ring

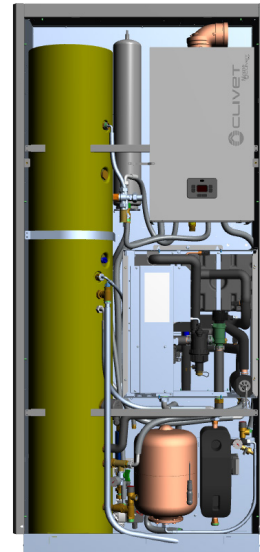

Standard indoor unit components

Standard indoor unit components

Standard indoor unit consisting of four systems shipped separately for greater installation flexibility on site:

- 1) Hydraulic control module (HQCN-NEE 1 IC)
- 2) Uncased additional practical cabinet (ADIX)
- 3) Domestic hot water storage (ACS150X)
- 4) Hydraulic connections kit (KCIACSX)

ADIX **Uncased additional practical cabinet for system accessories with fittings template**
Uncased additional practical cabinet for system accessories with structure made of galvanised sheet metal with brackets for anchoring in the brickwork and frames on the edge of the structure to hide any imperfections. The frames are attached to the front panels and adjustable for greater flexibility with different installations.

ACS150X **150L domestic hot water storage**
150L domestic hot water storage tank in AISI 316 stainless steel, outer insulation in polyurethane (20 mm thick) and cover in black PVC.

* Coil surface 1 m²

Including two Water tank + connection kit packs

- ⚠ Not compatible with KCVEX
- ⚠ To consult the technical data of the water tank, see the table in the relevant section.

KCIACSX **DHW tank connection kit for uncased unit**
DHW tank connection piping kit with indoor heat pump module.
Kit containing:

- Connection pipes
- Anti-scalding valve
- DHW pressure relief valve
- 8-litre DHW expansion tank

⚠ Note: Compatible only with IC version

AENVX **Additional aesthetic practical cabinet for system accessories in full view**
The additional aesthetic practical cabinet for system accessories is an option designed to allow the EasyIn hydronic module to be installed outside the home. The additional practical cabinet for system accessories offers optimal protection for the module and its internal components, ensuring aesthetically appealing and seamless integration with its surroundings. The intuitive design of the additional practical cabinet for system accessories simplifies installation of the hydronic module and its internal components.
Height: 2289 mm
Length: 1014 mm
Depth: 415 mm

- ⚠ The version with additional practical cabinet for system accessories in full view is only available as a main cabinet, additional external cabinets are not provided
- ⚠ Cabinet dimensions are given on the pages at the end of the technical bulletin.

SHWTX

150-litre DHW boiler with solar coil

150L domestic hot water storage tank in AISI 316 stainless steel, with additional coil for the thermal solar connection, outer insulation in polyurethane (20 mm thick) and cover in black PVC.

EH246X

Additional electric heater adjustable to three capacities of 2, 4 or 6 kW

EH9X

Additional electric heater adjustable to one capacity of 9 kW

Integration electric heater in STAINLESS STEEL with 2-4 kW single-phase or 6-9 kW three-phase capacities.

The electric heater can operate both for the system and for the production of domestic hot water in two different modes:

- as an integration, when the heat pump capacity is not enough to fulfil the required set point;
- as a safety element if the heat pump fails.

⚠ Configuration with additional electric heater excludes condensing boiler for integration/replacement (HYFE24 - HYFE34).

⚠ Selection of the additional three-phase electric heater changes the voltage of the indoor unit only. The power supply of the outdoor unit remains unchanged.

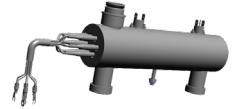

KIR2HX -

Hydraulic kit for managing two areas with the same temperature

KIR2HLX

Hydraulic kit for managing two areas with high and mixed temperature

Distribution module for 2-area heating systems with compact design and ample versatility for different types of indoor unit installation.

Kit consisting of:

- 1 collector / separator painted black;
- 2 circulators;
- 1 sliding temperature mixing valve (only in the KIR2HLX kit);
- 1 lower anti-rotation template;
- 1 module mounting bracket;
- connecting pipes
- 1 probe for managing the mixed circuit temperature (only in the KIR2HLX kit)

⚠ For technical pump head data, refer to the dedicated section in the GENERAL TECHNICAL DATA chapter.

⚠ Water booster kit excludes SICGX intermediate exchanger kit for glycol circuit

KCSIX

Kit for hydraulic separation between primary and secondary circuit with pump on secondary circuit

The single-area kit consists of a hydraulic separator combined with a high efficiency pump. Allows interaction between the primary circuit circulator and the secondary circuit circulator. Furthermore, the separator also has the function of a deaerator. With the following benefits and advantages:

- makes the connected hydraulic circuits independent;
- ensures effective operation of the secondary circulator that provides the hydraulic demand of air conditioning systems;
- air extraction system;

The kit consists of:

- 1 collector / separator painted black;
- 1 circulator;
- 1 lower anti-rotation template;
- 1 module mounting bracket;
- connecting pipes

⚠ For technical pump head data, refer to the dedicated section in the GENERAL TECHNICAL DATA chapter.

⚠ Water booster kit excludes SICGX intermediate exchanger kit for glycol circuit

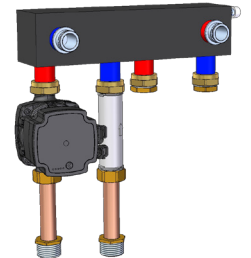

KPRSX

Pump kit for domestic water recirculation management

Kit offering the option of installing the pump needed for the booster circuit inside the unit.

It can be electrically connected to the outdoor unit's electrical panel, which is used to set the hourly schedule in order to optimise its operation.

The kit includes:

- 1 UPSO 15-55 circulator;
- 1 flexible hose for the connection;
- kit installation manual.

⚠ If any options are chosen: For ACSA50X and ACSA150X, the customer is responsible for managing the pump.



Accessories separately supplied

AC50X

50-litre inertial storage tank for indoor installation

Inertial tank to be installed inside the unit. In AISI 316 stainless steel with outer insulation in rigid polyurethane (20 mm thick) and black PVC cover. With a volume of 50 litres, it is suitable for all EDGE EVO 2.0 and EDGE F sizes; it also facilitates operation and helps to fulfil the thermal requirement, guaranteeing optimal modulation.

The kit consists of:

- 1 50-litre stainless steel inertial storage tank;
- 2 copper pipes for connecting the tank;
- screws, gaskets and brackets for fixing;
- connection pipe kit;
- kit installation manual.

⚠ The AC50X kit excludes the KCVEX, ACSA50X and HYFE24 kit.



ACE50X + ADI50X

50-litre inertial storage tank for outdoor installation

Uncased additional practical cabinet for system accessories for external inertial tank

Inertial tank to be installed outside the standard unit. In AISI 316 stainless steel with outer insulation in rigid polyurethane (20 mm thick) and black PVC cover. With a volume of 50 litres, it is suitable for all EDGE EVO 2.0 and EDGE 2.0 sizes; it also facilitates operation and helps to fulfil the thermal requirement, guaranteeing optimal modulation.

Two kits are required for connecting the external inertial storage tank:

- ADI50X - Uncased additional practical cabinet for system accessories for external inertial tank
- ACE50X - 50-litre inertial storage tank for outdoor installation

With these two kits the tank can be installed on top of the standard unit. The ADI50X kit consists of the additional practical cabinet for system accessories needed for installation, while the ACE50X kit consists of the following:

- 1 50-litre stainless steel inertial tank with relief valve;
- 2 flexible hoses for connecting the tank;
- screws, gaskets and brackets for fixing;
- connection pipe kit;
- kit installation manual.

⚠ Selection of the ACE50X kit includes the ADI50X kit.

⚠ See dimensions on page 40.

⚠ Requires KCAIAX accessory



ACSA50X

50-litre additional domestic hot water storage

Additional domestic hot water storage to be installed inside the standard unit. In AISI 316 stainless steel with outer insulation in rigid polyurethane (20 mm thick) and black PVC cover.

With a volume of 50 litres, you can actually have a total of 200 litres.

The kit consists of:

- 1 50-litre stainless steel DHW tank;
- 1 temperature probe L= 4.5 m;
- 2 copper pipes for connecting the water tank;
- 1 GRUNDFOS UPSO 15-55 circulator;
- screws, gaskets and brackets for fixing;
- kit installation manual.

⚠ The ACSA50X kit excludes the AC50X, ACSA150X and HYFE24 kit.

⚠ Requires KCAIAX accessory



DPX

Predisposition for hydraulic connection for the aesthetic cabinet

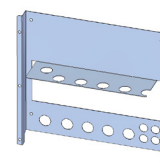

ACSA150X + 150-litre additional domestic hot water storage **ADIAX**

Uncased additional practical cabinet for system accessories for additional DHW tank

Additional domestic hot water storage to be installed outside the standard unit. In AISI 316 stainless steel with outer insulation in rigid polyurethane (20 mm thick) and black PVC cover. With a volume of 150 litres, you can actually have a total of 300 litres of domestic hot water.

Two kits are required for connecting the 150-litre additional external tank:

ADIAX - Uncased additional practical cabinet for system accessories for additional DHW tank

ACSA150X - 150-litre additional domestic hot water storage

KCI150X- Additional DHW tank connection kit for uncased unit

The KCI150X kit consists of:

- 1 8-litre expansion tank;
- 1 temperature probe L= 4.5 m
- 2 flexible hoses for connecting the water tank;
- 1 GRUNDFOS UPSO 15-55 circulator;
- screws, gaskets and brackets for fixing;
- kit installation manual.

The additional tank can be installed on the left or right side of the standard unit, or it can be controlled remotely; in the latter case additional connection pipes must be provided.

⚠ The ACSA150X kit excludes the ACSA50X kit.

⚠ See dimensions on page 35.



KCIBOIX **Boiler connection kit for instant DHW production**

Hydronic module connection kit when combined with integrated FE boiler.

SICGX **Intermediate exchanger for clean separation between primary and secondary circuit**

Braze-welded plate exchanger for clean separation of the water circuit between the outdoor unit, indoor unit and the system including the emitters. This allows less glycol to be used for frost protection of the entire part of the circuit exposed to the outdoor temperature.

To check the available pressure provided by the pump, refer to the specific curve pages 20-21

The kit consists of:

- Braze-welded plate exchanger
- Electronic circulator
- Connection piping

⚠ Intermediate exchanger kit for glycol circuit excludes KIR2HX - KIR2HLX water booster kit

⚠ Secondary circuit kit (1L hydraulic circuit breaker + pump) KCSIX

Accessories separately supplied

KCVEX

Circulation kit: circulation unit, electric control box, expansion tank

Circulation kit: circulation unit, electric control box, expansion tank.

The circuit has a high efficiency heat exchange. This is because an additional exchanger is fitted inside the DHW tank to allow the hot water from the solar manifolds to exchange its energy directly with that contained in the tank. This prevents double heat exchange and increases efficiency.

The kit consists of:

- 1 18-litre expansion tank with fixing bracket;
 - 2 PT1000 temperature probes;
 - 1 shut-off ball valve with MF 3/4" threaded fittings;
 - 1 electronic control unit with fixing bracket;
 - 1 forced circulation solar return unit including:
 - WILO PARA ST 15/7 iPWM circulator;
 - 2-12 l/min flow regulator;
 - 1/2" M shut-off valve for system loading/discharge/washing;
 - DN 20 VRM3 return ball valve with check valve;
 - thermometer;
 - black EPP front and rear insulation shell;
 - safety unit with: 0-10 bar pressure gauge, 6 bar pressure relief valve;
 - fitting for connection to the expansion tank;
- flexible pipes for connecting the DHW tank kit;
screws, gaskets and brackets for fixing;

⚠ For electrical and technical data on the circulator, refer to the "Electrical data" and "KCVEX available pressure" sections.

⚠ If the solar kit is selected, the unit should be selected with a specific tank with double coil (SHWTX), one for the heat pump and one for the solar system.

Option compatibility

The following table can be used to check whether more than one accessory can be selected at the same time.

Internal compatibility for EASYIN	ACCESSORIES SUPPLIED SEPARATELY					
	EH246X - EH9X	KCSIX - KIR2HX - KIR2HLX	SICGX	ACSA150X	SHWTX	KCVEX
EH246X - EH9X	-	●	●	●	●	●
KCSIX - KIR2HX - KIR2HLX	●	-	-	●	●	●
SICGX	●	-	-	●	-	-
ACSA150X	●	●	●	-	●	●
SHWTX	●	●	●	●	-	●
KCVEX	●	●	-	●	●	-
AC50X	●	●	-	●	●	●
ACE50X	●	●	●	●	●	●
ACSA50X	●	●	-	-	●	●
KCH150X	●	●	●	●	●	●
KPRSX	●	●	-	-	●	●
AENVX	●	●	●	-	●	●
DPX	●	●	●	-	●	●
KCIBOIX	-	●	●	●	●	●

Accessories separately supplied

Option compatibility

ACCESSORIES SUPPLIED SEPARATELY

AC50X	ACE50X	ACSA50X	KC1150X	KPRSX	AENVX	DPX	KCIBOIX
•	•	•	•	•	•	•	-
•	•	•	•	•	•	•	•
-	•	-	•	-	•	•	•
•	•	-	•	-	-	-	•
•	•	•	•	•	•	•	•
•	•	•	•	•	•	•	•
-	-	-	•	•	•	•	-
-	-	•	•	•			•
-	•	-	-	-	•	•	-
•	•	-	-	-	-	-	•
•	•	-	-	-	•	•	•
•	-	•	-	•	-	•	•
•	-	•	-	•	•	-	•
-	•	-	•	•	•	•	-

Compatibility of options for EASYIN + EDGE Hydro-Split system.

When combining EASYBOX and EDGE units, the following options can be selected for the packaged unit:

“Hybrid configuration” section

- GAS BOILER_UC / GAS BOILER_FE 24.4-33.4 - 4-pipe condensing boiler for hybrid heat pumps
- KCSAFX - ø 60/100 mm vertical coaxial fitting
- CCOAX - 90° coaxial elbow for ø 60/100 mm horizontal outlet that can be adjusted at 360°
- TCOAX - L1000mm ø 60/100 coaxial pipe with terminal

⚠ "Hybrid configuration" not compatible with options: EH246X- Additional electric heater adjustable to three capacities of 2, 4 or 6 kW
EH9X- Additional electric heater adjustable to one capacity of 9 kW

“Configuration with solar thermal panels” section

- ELFOSun3

“Other accessories supplied separately” section

- KTFLEX - Hose kit for connection to the unit
- VAGX - Safety antifreeze valve for system
- DTX - Drain pan with electric heater
- AMRX - Kit of antivibration mounts for floor installation
- AMMSX - Kit of anti-seismic antivibration mounts for floor installation
- ASTFX - Kit of antivibration mounts for installation on wall brackets, inertial storage tank or tray
- KSIPX - Wall fixing bracket kit
- HTC2WX - White HID-TConnect 2 chronothermostat for temperature control
- CONTROL4 NRG

For all plant accessories, please refer to the EASYIN ACCESSORIES.

Construction characteristics - Indoor unit

SIZE			A
System characteristics			
Maximum system pressure		bar	3,0
System expansion tank	1	l	8,0
Expansion tank pre-charging		bar	1,0
System water connections		inch	1"
DHW Characteristics			
Type of Tank			AISI 316L stainless steel
Domestic hot water Tank Volume		l	150
Internal coil exchange surface		m ²	1,0
Water tank leakage		W/K (kWh/24h)	1.69 (1.82)
DHW safety electric heater		kW	2,0
Maximum DHW circuit pressure		bar	6,0
DHW expansion tank		l	8,0
Domestic water connections		inch	3/4"
Size			
Operation (L x W x H)		mm	950 x 360 x 2200
Packaging (L x W x H)		mm	2300 x 430 x 1225
Operating weight		kg	50
Shipping weight		kg	47

1. Sufficient volume up to a maximum of 70 litres of system water content.

General technical data

Hydraulic data - Indoor unit + Outdoor unit - R32

SIZE		2.1	3.1	4.1	5.1
Minimum system water content	l	30	30	70	70
Minimum water flow rate allowed	l/s	0,11	0,11	0,11	0,11
Maximum water flow rate allowed	l/s	0,25	0,35	0,46	0,58
Net boiler capacity	l	143	143	143	143
DHW tank setpoint	°C	50	50	50	50
Water mixed at 40 °C (V40)	l	188	188	188	188
Heating time	h:min	02:11	02:11	01:47	01:47
Energy consumption during heating	kWh	1,90	1,90	2,00	2,00



1. The minimum water content of the area with the smallest water volume is considered.

Hydraulic data - Indoor unit + Outdoor unit - R290

SIZE		2.1	3.1	4.1	5.1
Minimum system water content	l	30	30	70	70
Minimum water flow rate allowed	l/s	0,10	0,10	0,17	0,17
Maximum water flow rate allowed	l/s	0,42	0,42	0,64	0,69
Net boiler capacity	l	143	143	143	143
DHW tank setpoint	°C	50	50	50	50
Water mixed at 40°C (V40)	l	188	188	188	188
Heating time	h:min	01:44	01:44	01:18	01:18
Energy consumption during heating	kWh	2,10	2,10	2,25	2,25



1. The minimum water content of the area with the smallest water volume is considered.

The use of glycol and the intermediate heat exchanger changes the performance of the machine: it is possible to estimate the operating performance by multiplying the correction factors by the nominal operating values

Ethylene glycol table

MIN outdoor temperature	Glycol concentration	Correction factors			
		Capacity	Power input	Water resistance	Water flow
0°C	0%	0,985	1	1	1
-5°C	10%	0,973	0,998	1,118	1,019
-15°C	20%	0,964	0,995	1,268	1,051
-25°C	30%	0,958	0,992	1,482	1,092

Propylene glycol table

MIN outdoor temperature	Glycol concentration	Correction factors			
		Capacity	Power input	Water resistance	Water flow
0°C	0%	0,978	1	1	1
-5°C	10%	0,963	0,996	1,071	1
-15°C	20%	0,951	0,992	1,189	1,016
-25°C	30%	0,942	0,988	1,380	1,034

⚠ The glycol concentration must never be > 30%.

EDGE EVO 2.0 performance

Heating

SIZE		2.1	3.1	4.1	5.1
Air 7 °C - Water 35 °C					
Rated heating capacity	1 kW	4,20	6,35	8,40	10,0
Total power input	1 kW	0,82	1,28	1,63	2,02
COP	1 -	5,10	4,95	5,15	4,95
Water flow rate	1 l/s	0,20	0,30	0,40	0,48
Nominal available pressure	1 kPa	85	84	80	71
Air 2 °C - Water 35 °C					
Rated heating capacity	2 kW	4,40	5,50	7,10	8,20
Total power input	2 kW	1,10	1,41	1,73	2,05
COP	2 -	4,00	3,90	4,10	4,00
Water flow rate	2 l/s	0,21	0,26	0,34	0,39
Nominal available pressure	2 kPa	85	85	82	80
Air -7 °C - Water 35 °C					
Rated heating capacity	3 kW	4,70	6,00	7,00	8,00
Total power input	3 kW	1,52	2,00	2,19	2,62
COP	3 -	3,10	3,00	3,20	3,05
Water flow rate	3 l/s	0,22	0,29	0,33	0,38
Nominal available pressure	3 kPa	85	85	83	81
Air 7 °C - Water 45 °C					
Rated heating capacity	4 kW	4,30	6,30	8,10	10,0
Total power input	4 kW	1,13	1,70	2,10	2,67
COP	4 -	3,80	3,70	3,85	3,75
Water flow rate	4 l/s	0,21	0,30	0,39	0,48
Nominal available pressure	4 kPa	85	85	80	70
Air 7 °C - Water 55 °C					
Rated heating capacity	5 kW	4,40	6,00	7,50	9,50
Total power input	5 kW	1,49	2,03	2,36	3,06
COP	5 -	2,95	2,95	3,18	3,10
Water flow rate	5 l/s	0,21	0,29	0,36	0,45
Nominal available pressure	5 kPa	85	85	82	75

Data according to EN 14511:2018.

1. entering/leaving water temperature 30/35 °C, outdoor air temperature -7 °C dry bulb / -6 °C wet bulb
2. entering/leaving water temperature 30/35 °C, outdoor air temperature -2 °C dry bulb / -1 °C wet bulb
3. entering/leaving water temperature 30/35 °C, outdoor air temperature -7 °C dry bulb / -8 °C wet bulb
4. entering/leaving water temperature 40/45 °C, outdoor air temperature 7 °C dry bulb / 6 °C wet bulb
5. entering/leaving water temperature 47/55 °C, outdoor air temperature 7 °C dry bulb / 6 °C wet bulb

Cooling

SIZE		2.1	3.1	4.1	5.1
Air 35 °C - Water 18 °C					
Nominal cooling capacity	6 kW	4,50	6,50	8,30	9,90
Total power input	6 kW	0,82	1,35	1,64	2,18
EER	6 -	5,50	4,80	5,05	4,55
Water flow rate	6 l/s	0,22	0,31	0,40	0,47
Nominal available pressure	6 kPa	85	84	80	71
Air 35 °C - Water 7 °C					
Nominal cooling capacity	7 kW	4,70	7,00	7,45	8,20
Total power input	7 kW	1,36	2,33	2,22	2,52
EER	7 -	3,45	3,00	3,35	3,25
Water flow rate	7 l/s	0,22	0,33	0,36	0,39
Nominal available pressure	7 kPa	85	83	82	80

Data according to EN 14511:2018.

6. entering/leaving water temperature 23/18 °C, outdoor air temperature -35 °C dry bulb / -27 °C wet bulb
7. entering/leaving water temperature 12/7 °C, outdoor air temperature -35 °C dry bulb / -27 °C wet bulb

General technical data

EDGE F performance

Heating

SIZE			2.1	3.1	4.1	5.1
Air 7 °C - Water 35 °C						
Rated heating capacity	1	kW	4,50	6,20	8,40	10,0
Total power input	1	kW	0,87	1,27	1,68	2,13
COP	1	-	5,15	4,90	5,00	4,70
Water flow rate	1	l/s	0,21	0,30	0,40	0,48
Nominal available pressure	1	kPa	89	87	80	71
Air 2 °C - Water 35 °C						
Rated heating capacity	2	kW	4,40	5,60	7,10	8,20
Total power input	2	kW	1,07	1,44	1,84	2,25
COP	2	-	4,10	3,90	3,85	3,65
Water flow rate	2	l/s	0,21	0,27	0,34	0,39
Nominal available pressure	2	kPa	89	88	85	80
Air -7 °C - Water 35 °C						
Rated heating capacity	3	kW	4,50	5,90	7,00	8,00
Total power input	3	kW	1,45	2,00	2,33	2,81
COP	3	-	3,10	2,95	3,00	2,85
Water flow rate	3	l/s	0,21	0,28	0,33	0,38
Nominal available pressure	3	kPa	89	88	85	80
Air 7 °C - Water 45 °C						
Rated heating capacity	4	kW	4,50	6,40	8,20	10,0
Total power input	4	kW	1,11	1,68	2,13	2,74
COP	4	-	4,05	3,80	3,85	3,65
Water flow rate	4	l/s	0,21	0,30	0,39	0,48
Nominal available pressure	4	kPa	89	87	80	71
Air 7 °C - Water 55 °C						
Rated heating capacity	5	kW	4,60	6,20	7,80	9,50
Total power input	5	kW	1,44	2,00	2,44	3,11
COP	5	-	3,20	3,10	3,20	3,05
Water flow rate	5	l/s	0,14	0,18	0,23	0,28
Nominal available pressure	5	kPa	90	89	86	85

Data according to EN 14511:2022.

1. entering/leaving water temperature 30/35 °C, outdoor air temperature -7 °C dry bulb / -6 °C wet bulb
2. entering/leaving water temperature 30/35 °C, outdoor air temperature -2 °C dry bulb / -1 °C wet bulb
3. entering/leaving water temperature 30/35 °C, outdoor air temperature 7 °C dry bulb / 8 °C wet bulb
4. entering/leaving water temperature 40/45 °C, outdoor air temperature 7 °C dry bulb / 6 °C wet bulb
5. entering/leaving water temperature 47/55 °C, outdoor air temperature 7 °C dry bulb / 6 °C wet bulb

Cooling

SIZE			2.1	3.1	4.1	5.1
Air 35 °C - Water 18 °C						
Nominal cooling capacity	1	kW	4,50	6,50	8,30	10,0
Total power input	1	kW	0,82	1,27	1,61	2,11
EER	1	-	5,50	5,10	5,15	4,75
Water flow rate	1	l/s	0,21	0,31	0,40	0,48
Nominal available pressure	1	kPa	89	87	80	71
Air 35 °C - Water 7 °C						
Nominal cooling capacity	2	kW	4,70	6,80	7,50	8,90
Total power input	2	kW	1,29	2,19	2,17	2,74
EER	2	-	3,65	3,10	3,45	3,25
Water flow rate	2	l/s	0,22	0,32	0,36	0,42
Nominal available pressure	2	kPa	89	86	83	81

Data according to EN 14511:2022

1. entering/leaving water temperature 23/18 °C, outdoor air temperature -35 °C dry bulb / -27 °C wet bulb
2. entering/leaving water temperature 12/7 °C, outdoor air temperature -35 °C dry bulb / -27 °C wet bulb

Electrical data

Standard EASYIN indoor unit

Power supply 220-240V ~ 50Hz

Electrical current consumption of the DHW Electric heater	A	10,1
Power input of the DHW Electric heater	kW	2
Total electrical current consumption	A	10,6
Total power input	kW	2,10

Power supply 220-240v ~ 50Hz ±10%.

The units comply with the requirements of European standard IEC EN 60335.

Indoor unit configured with single-phase integration electric heaters

Power supply 220-240V ~ 50Hz

		2 kW	4 kW
F.L.A. - Current consumption of the unit with increased head circulator	A	10,1	20,2
F.L.I. - Power input of the unit with increased head circulator	kW	2	4

Power supply 220-240v ~ 50Hz ±10%.

The units comply with the requirements of European standard IEC EN 60335.

Data to be added to standard unit values

Indoor unit configured with three-phase integration electric heaters

Power supply 220-240V ~ 50Hz

		6 kW	9 kW
F.L.A. - Current consumption of the unit with single-phase electric heater	A	10,1	15,2
F.L.I - Power input of the unit with single-phase electric heater	kW	6	9

Power supply 220-240V ~ 50Hz +/-10%.

The units comply with the requirements of European standards EN 60335-1 and EN 60335-2-40.

Data to be added to standard indoor unit values.

Water booster kit: both high temperature - 2 areas: high + low temperature (mixed)

Power supply 380-415V ~ 50Hz

F.L.A. - Absorbed current at maximum admissible conditions	A	0,6
F.L.I - Power input at full load (at maximum conditions allowed)	W	120

Power supply 380-415V ~ 50Hz +/-6%.

The units comply with the requirements of European standards EN 60335-1 and EN 60335-2-40.

Data to be added to standard indoor unit values.

General technical data

Single area booster kit

Power supply 220-240V ~50Hz

F.L.A. - Absorbed current at maximum admissible conditions	A	0,3
F.L.I - Power input at full load (at maximum conditions allowed)	W	60

Power supply 220-240V ~ 50Hz +/-10%.

The units comply with the requirements of European standards EN 60335-1 and EN 60335-2-40.

Data to be added to standard indoor unit values.

Domestic water recirculation pump kit - 50-litre and 150-litre additional domestic hot water storage

Power supply 220-240V ~50Hz

F.L.A. - Absorbed current at maximum admissible conditions	A	0,4
F.L.I - Power input at full load (at maximum conditions allowed)	W	75

Power supply 220-240V ~ 50Hz +/-10%.

The units comply with the requirements of European standards EN 60335-1 and EN 60335-2-40.

Data to be added to standard indoor unit values.

Integration condensing boiler

Power supply 220-240V ~50Hz

F.L.A. - Absorbed current at maximum admissible conditions	A	0,5
F.L.I - Power input at full load (at maximum conditions allowed)	W	99

Power supply 220-240V ~ 50Hz +/-10%.

The units comply with the requirements of European standards EN 60335-1 and EN 60335-2-40.

Data to be added to standard indoor unit values.

Solar option kit - Glycol water exchanger kit

Power supply 220-240V ~50Hz

F.L.A. - Absorbed current at maximum admissible conditions	A	0,4
F.L.I - Power input at full load (at maximum conditions allowed)	W	75

Power supply 220-240V ~ 50Hz +/-10%.

The units comply with the requirements of European standards EN 60335-1 and EN 60335-2-40.

Data to be added to standard indoor unit values.

Condensing boiler general data

Indoor unit (HQCN-NEE 1 IC + HYFE24 - HYFE34 accessory)

MODEL				FE 24.4	FE 34.4
Heating Performance					
Nominal heating capacity (Qn)	-	Max	[kW]	24,5	34,8
		Min	[kW]	4,8	5,0
Heating capacity (Pn)	60/80°C	Max	[kW]	24,0	34,0
		Min	[kW]	4,7	4,9
	30/50°C	Max	[kW]	26,0	37,0
		Min	[kW]	5,2	5,4
Efficiency	60/80°C	Max	%	97,8	97,7
		Min	%	97,6	97,2
	30/50°C	Max	%	106,1	106,2
		Min	%	107,3	107,1
30% di Pn	-	%	109,7	109,7	
Heated water content	-	-	[l]	3,4	4,3
Operating pressure	PMS	Max	[bar]	3	3
	-	Min	[bar]	0,8	0,8
Expansion tank	Volume	-	[l]	8	10
	Pre-charging	-	[bar]	0,8	0,8
DHW performance					
Nominal heating capacity (Qnw)	-	Max	[kW]	28,5	34,8
		Min	[kW]	4,7	5,0
Heating capacity	-	Max	[kW]	28,0	34,0
		Min	[kW]	4,7	4,8
DHW flowrate	ΔT=25°C	-	[l/min]	16,1	19,5
	ΔT=30°C	-	[l/min]	13,4	16,2
	ΔT=45 K	-	[l/min]	8,9	10,8
	ΔT=40 K	-	[l/min]	10,0	12,1
DHW production in continuous operation	ΔT=35 K	-	[l/min]	11,5	13,9
	ΔT=30 K	-	[l/min]	13,4	16,2
	ΔT=25 K	-	[l/min]	16,1	19,5
Water temperature		Max	[°C]	65	65
		Min	[°C]	40	40
Operating pressure	PMW	Max	[bar]	9	9
	-	Min	[bar]	0,3	0,3
ErP data					
Seasonal eff. Average climate	Heating	ηs	%	94	94
		Energy class	-	A	A
	ACS	ηwh	%	85	85
		Energy class	-	A	A
		Withdrawal profile	-	XL	XXL
Sound power level		Lwa	[dB(A)]	49	52
Thermal losses and smoke exhaust					
Chimney loss	"burner ON 80/60°C"	Pmax	%	2,00	2,10
		Pmin	%	2,00	2,90
	"burner ON 50/30°C"	Pmax	%	1,40	1,40
		Pmin	%	1,00	1,00
Smoke temperature	80/60°C	Pmax	[°C]	66	67
		Pmin	[°C]	64	62
	50/30°C	Pmax	[°C]	52	53
		Pmin	[°C]	44	45
Smoke flowrate	-	Pmax	[g/s]	11,2	16
	-	Pmin	[g/s]	2,3	2,4
Nitrogen oxide (NOX) emissions		Class	-	6	6
		-	[mg/kWh]	35	33

General technical data

Indoor unit pressure drops

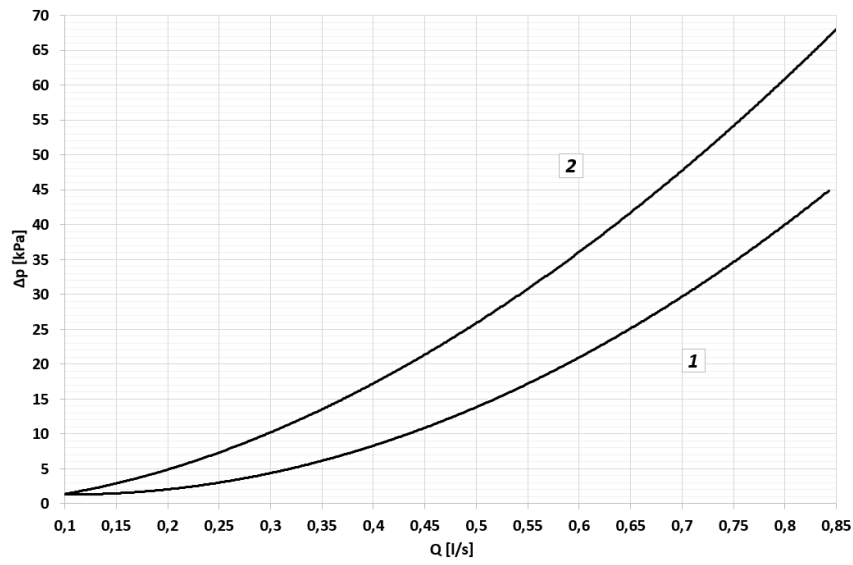

ΔP [kPa] = Pressure drops
Q [l/s] = Water flow-rate

1. STANDARD indoor unit pressure drops
 2. Pressure drops with SICGX option
- Note: EH246X-EH09X have negligible drops

Available pressure - KIR2HX - KIR2HLX

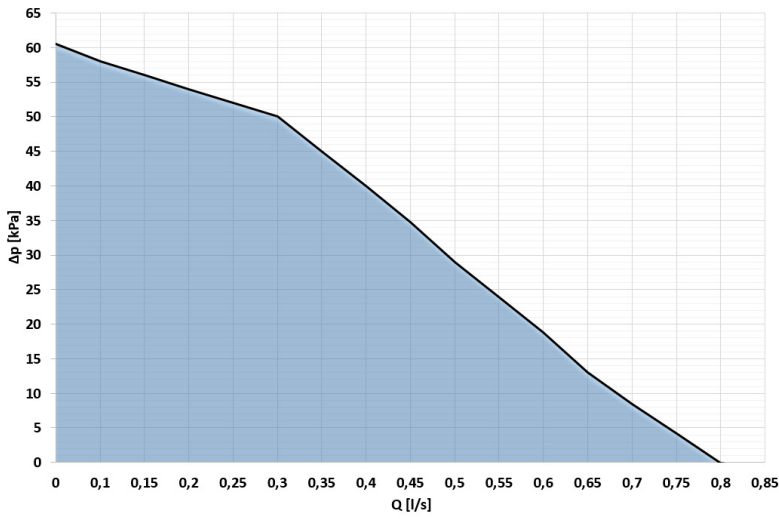

ΔP [kPa] = Available pressure
Q [l/h] = Water flow-rate

■ Circulator operating range

Available pressure - KCSIX

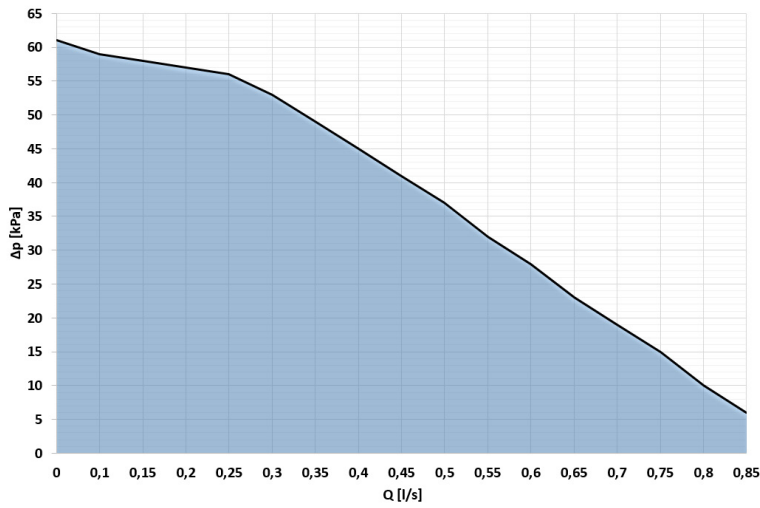

ΔP [kPa] = Available pressure
Q [l/h] = Water flow-rate

■ Circulator operating range

General technical data

Available pressure - SICGX

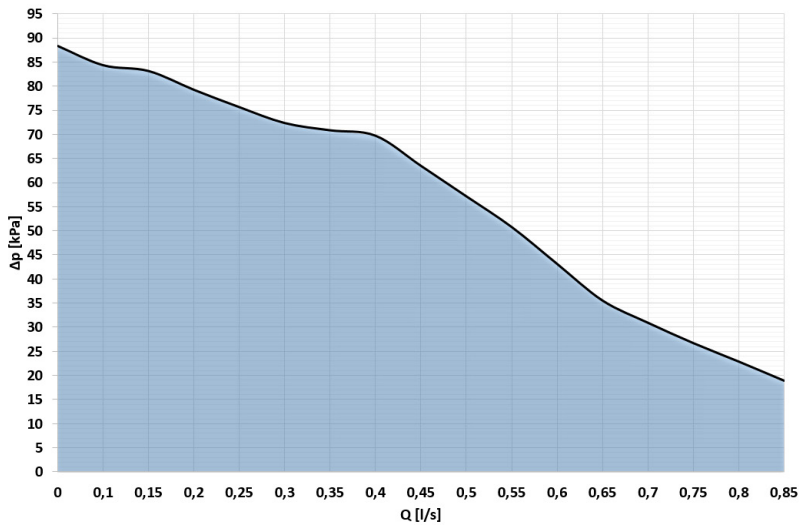

ΔP [kPa] = Available pressure
Q [l/h] = Water flow-rate

■ Circulator operating range

Available pressure - KCVEX

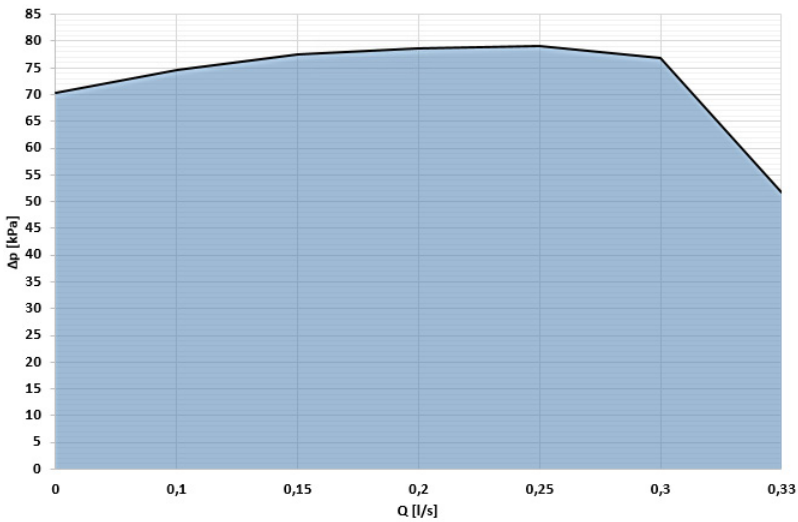

ΔP [kPa] = Available pressure
Q [l/h] = Water flow-rate

■ Circulator operating range

Hydraulic line sizing

Equivalent length of the lines (metres) = actual length (metres) + quantity of bends x K
 Use the K value from the following table

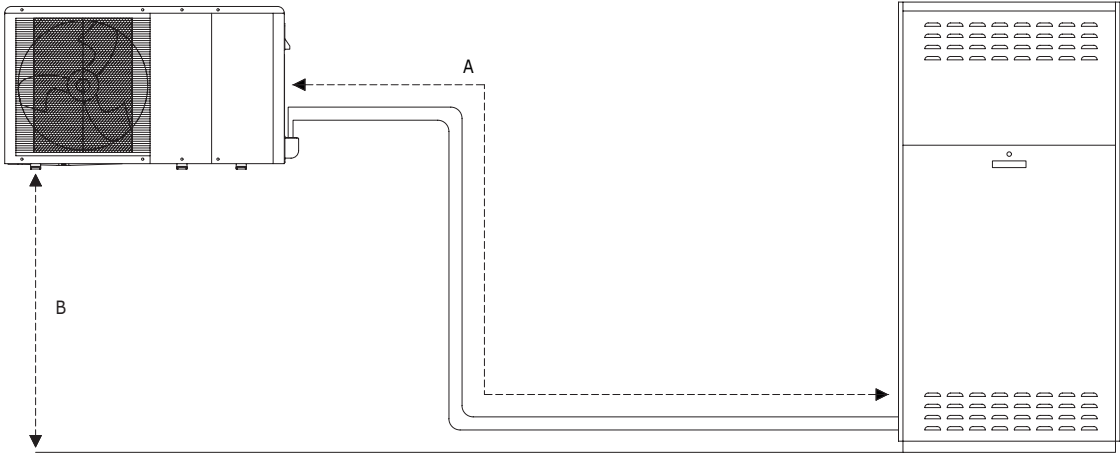

SIZE		2.1	3.1	4.1	5.1
K values					
standard 90° elbow bend	m	0,6	0,6	0,9	0,9
45° bend (standard)	m	0,3	0,3	0,3	0,3
Length and height difference of hydraulic lines					
A- Minimum/maximum equivalent length of hydraulic lines	m	2 - 25	2 - 25	2 - 25	2 - 25
B- Maximum height difference of hydraulic lines	m	20	20	20	20

Recommended diameter, the one the same size as the connection on the outdoor unit.

Note: for height differences of more than 12 metres, adjust the pre-charge of the expansion vessel of the outdoor unit.

Electrical connections

The electrical connection must be carried out in compliance with the national regulations in force. The connection must be carried out by specialised personnel who are qualified to work with live voltage.

The EDGE + EASYIN system can be controlled with the control panel on the unit. The unit can be called using: the CONTROL4 NRG supervisory system or common electromechanical thermostats.

Refer to the installation manual for more information on the connections.

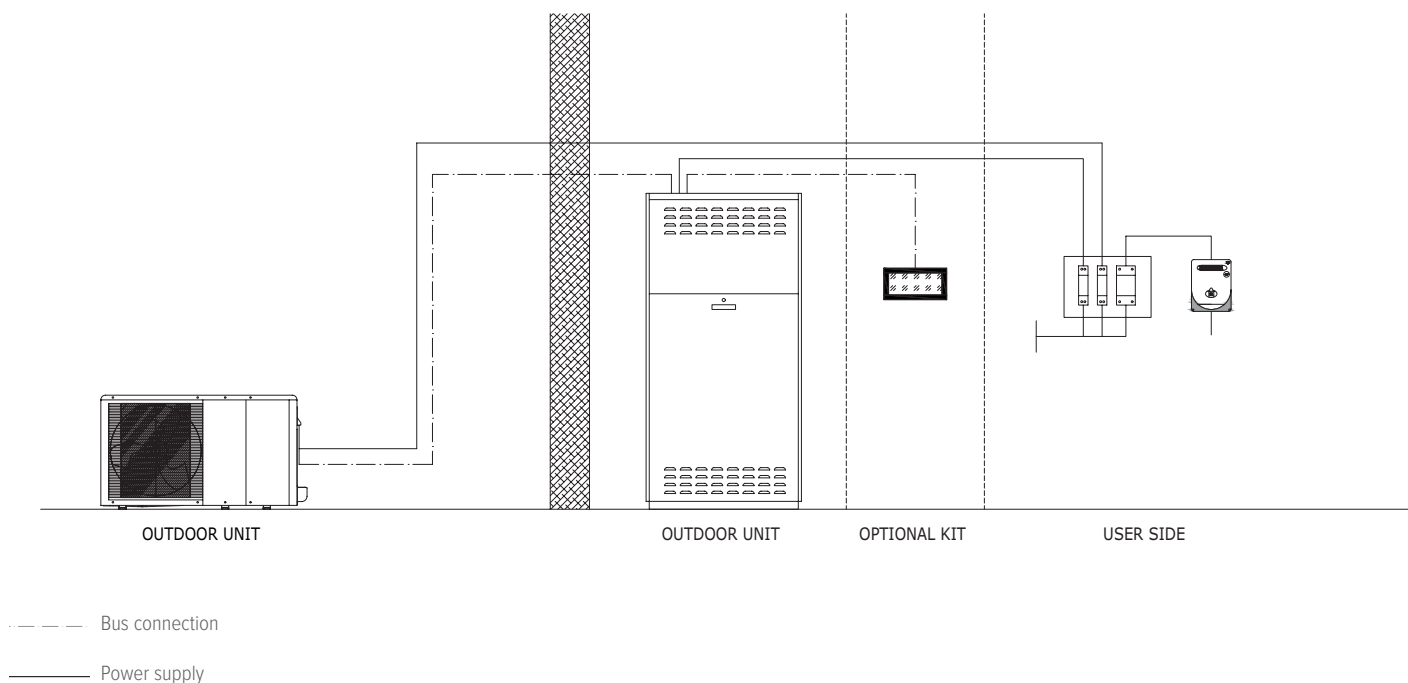

General description of the system and possible connections

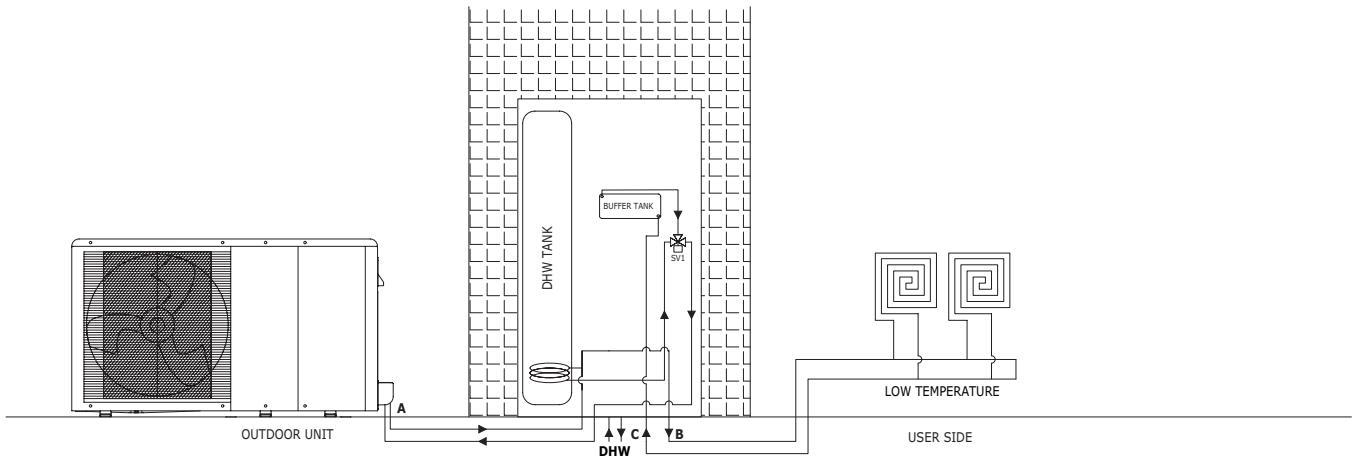

Standard

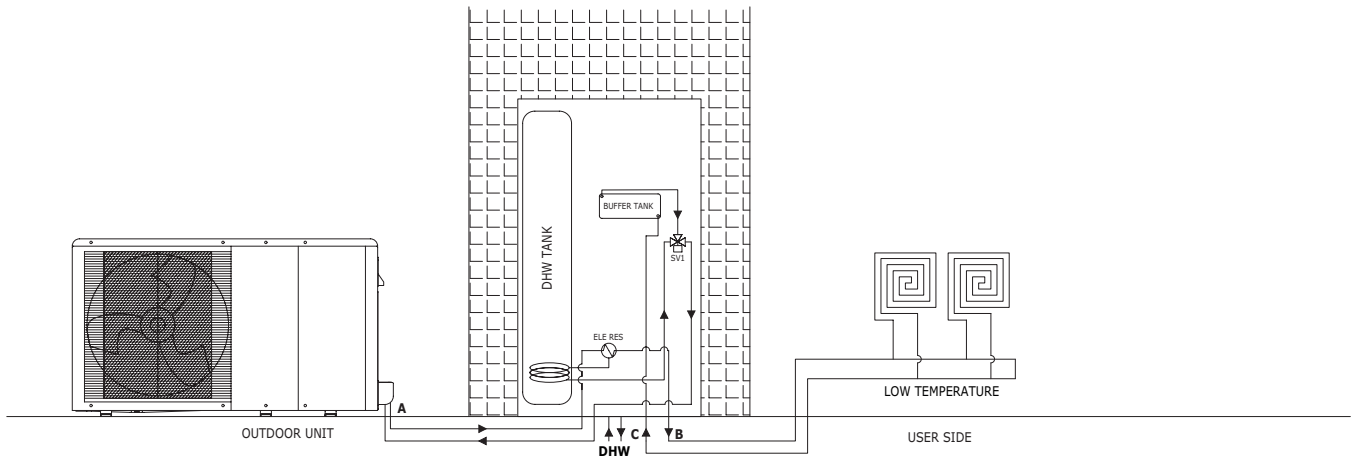

TBH backup

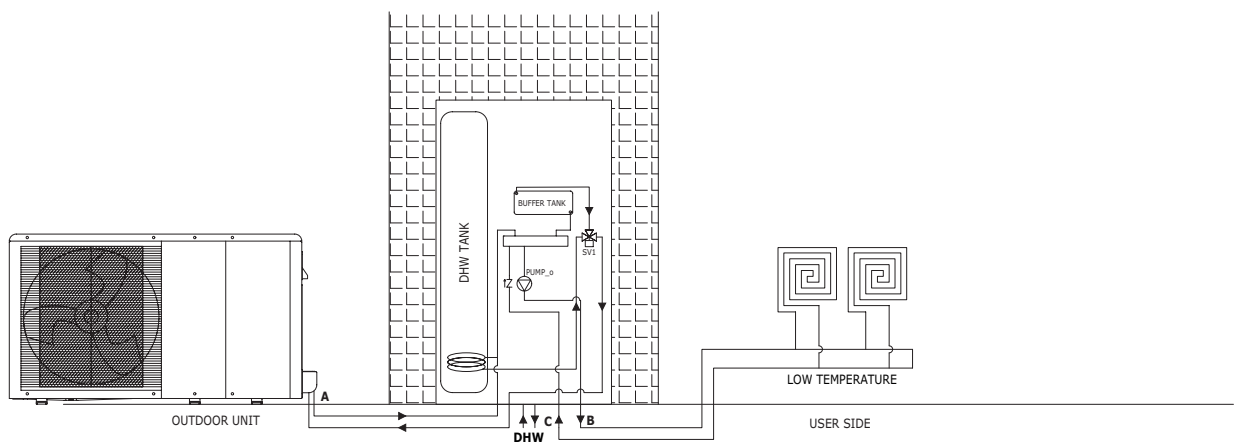

Single-area kit

System connections

General description of the system and possible connections

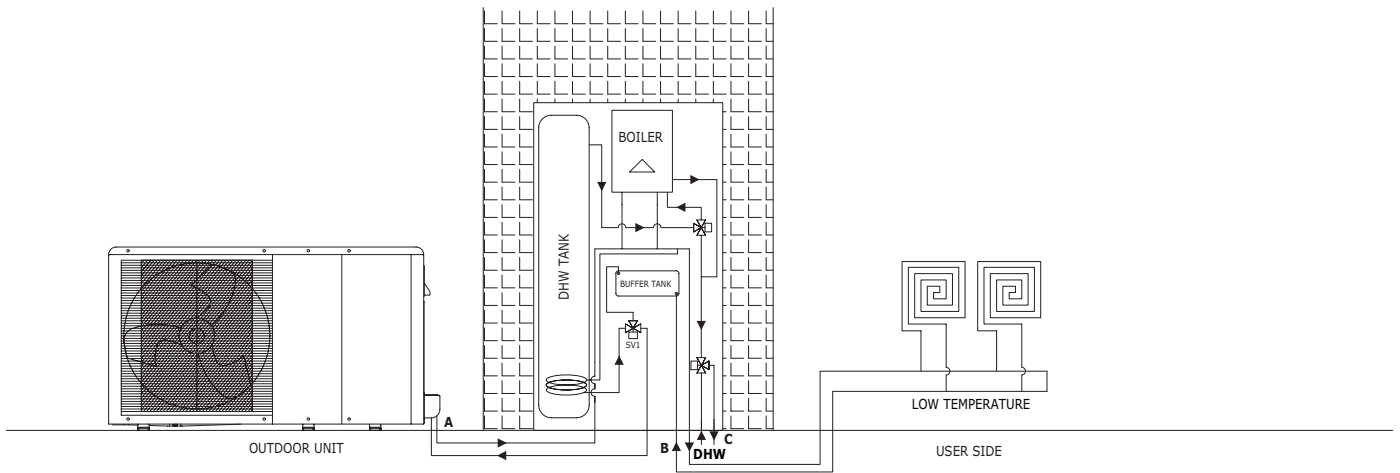

boiler + single-area kit solution

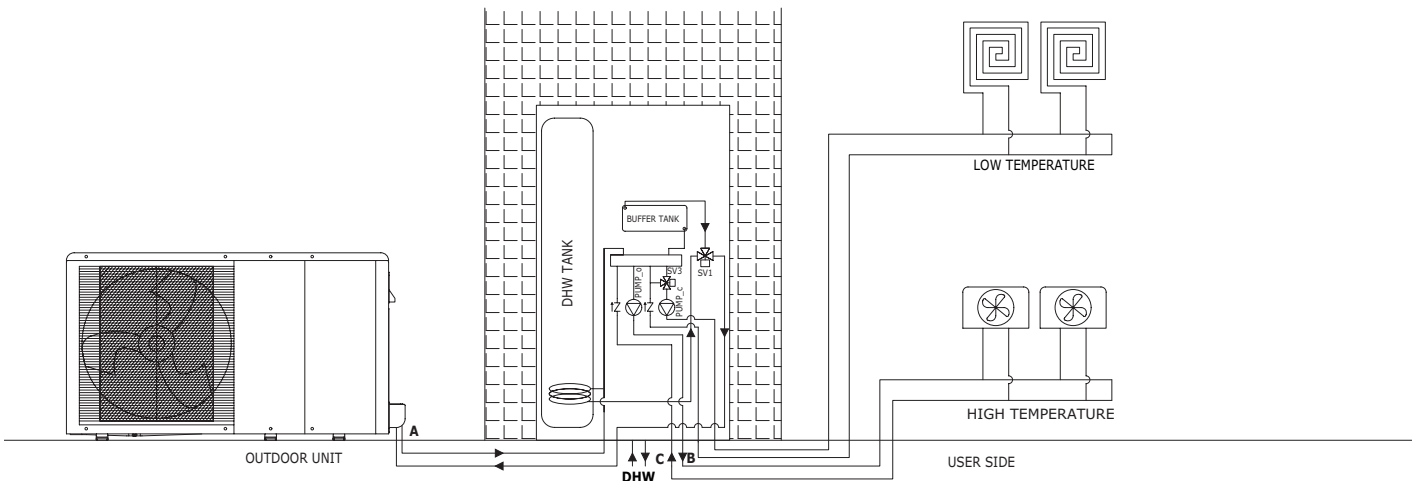

Kit for 2 AT-BT areas

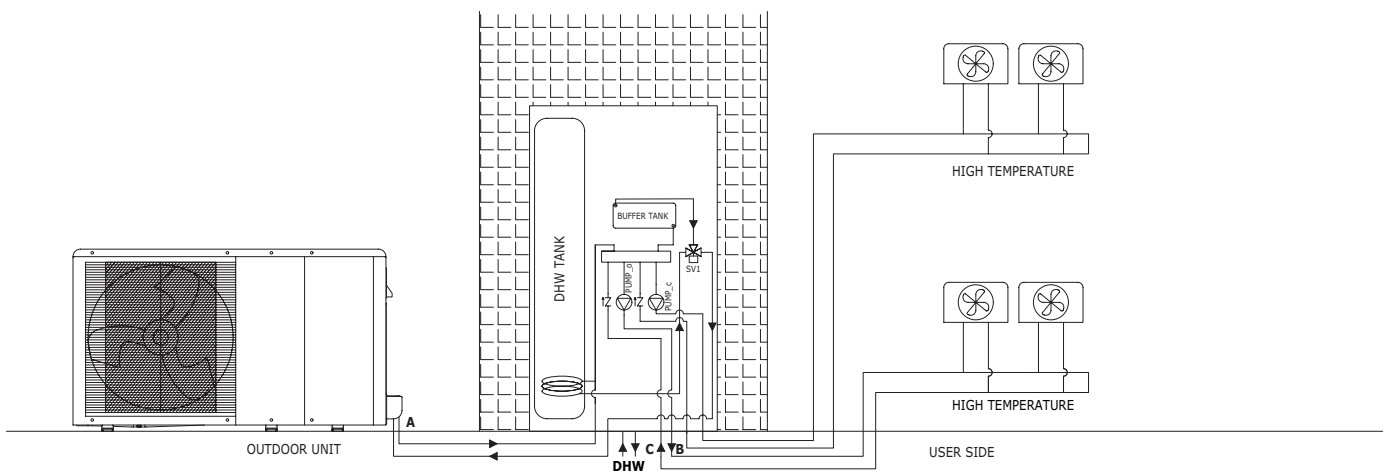

Kit for 2 AT-AT areas

General description of the system and possible connections

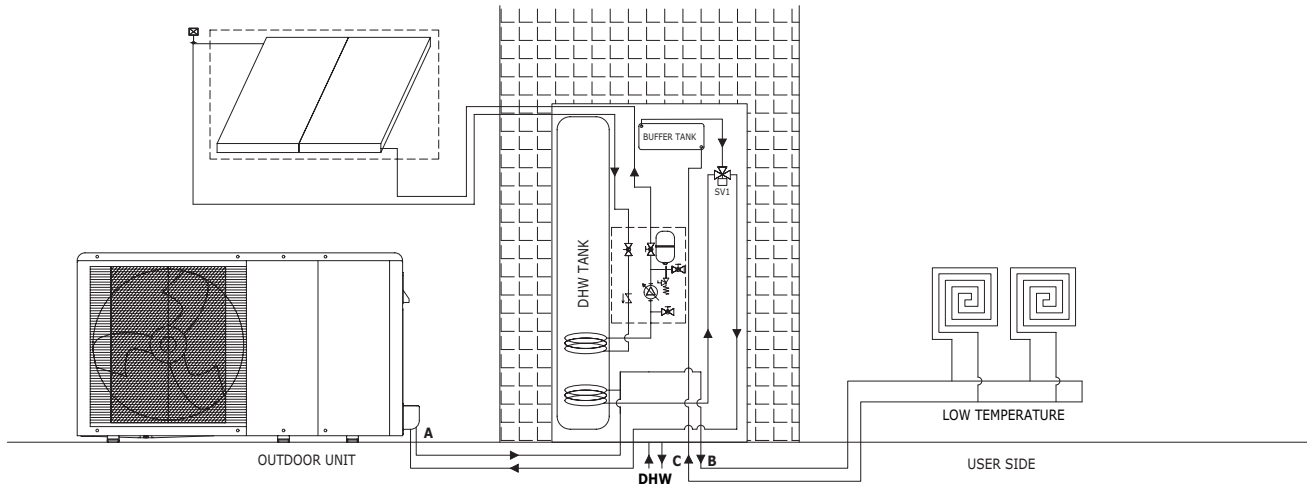

Solar kit

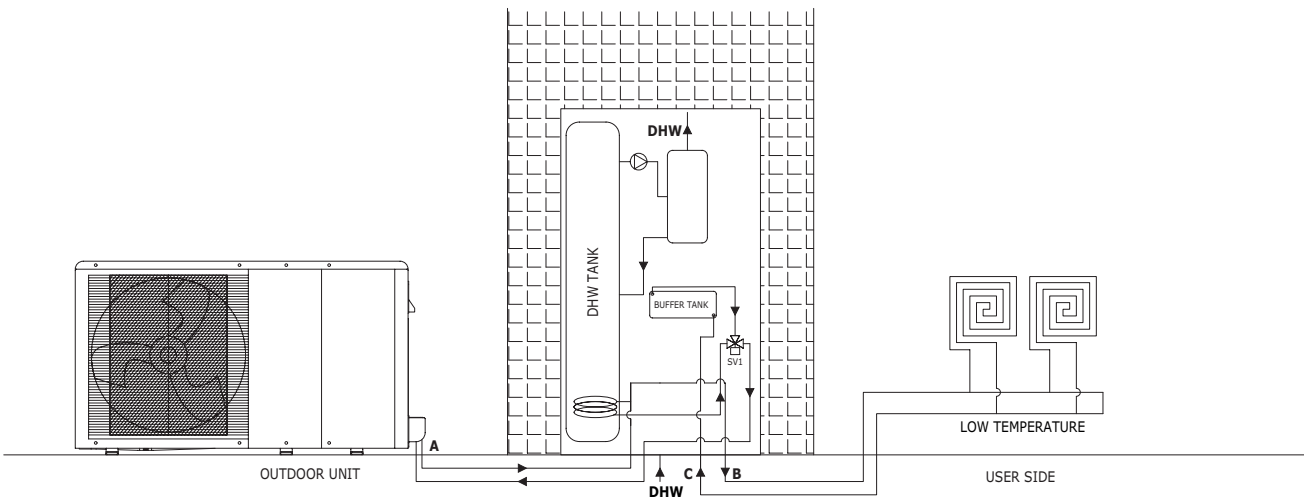

50L DHW tank

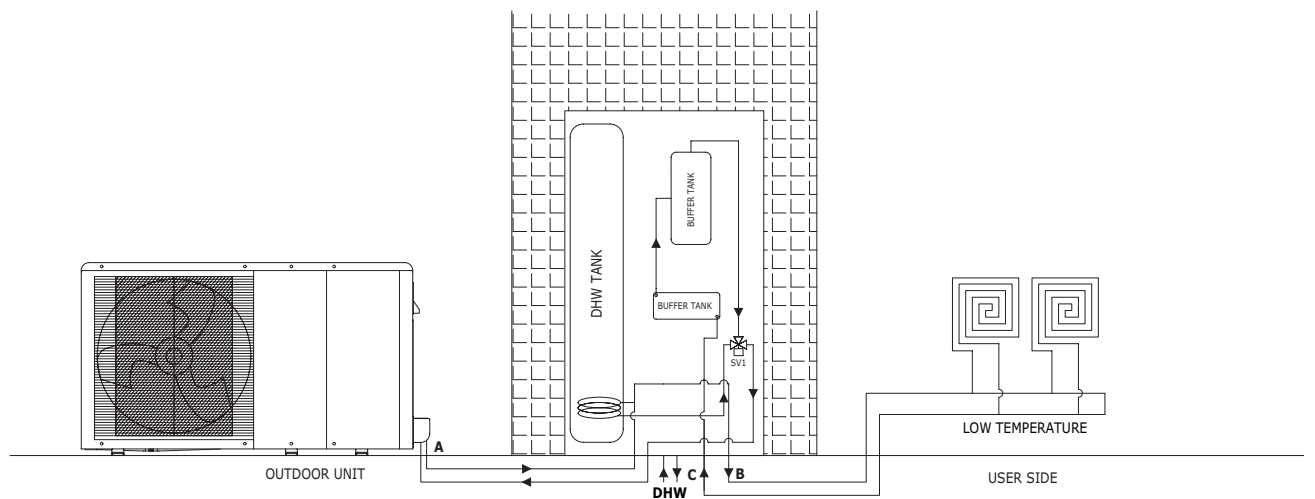

System 50L water tank

System connections

General description of the system and possible connections

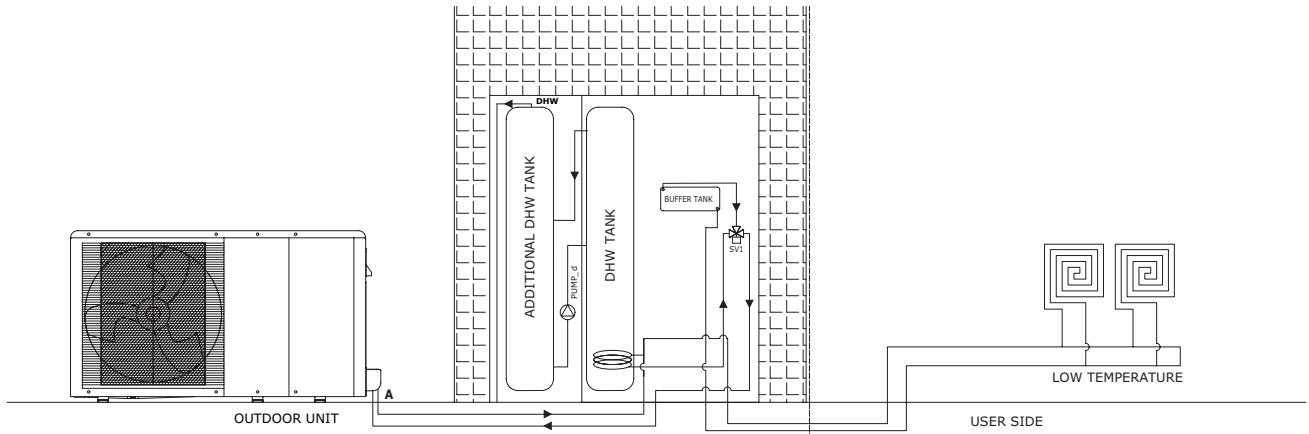

150L DHW tank

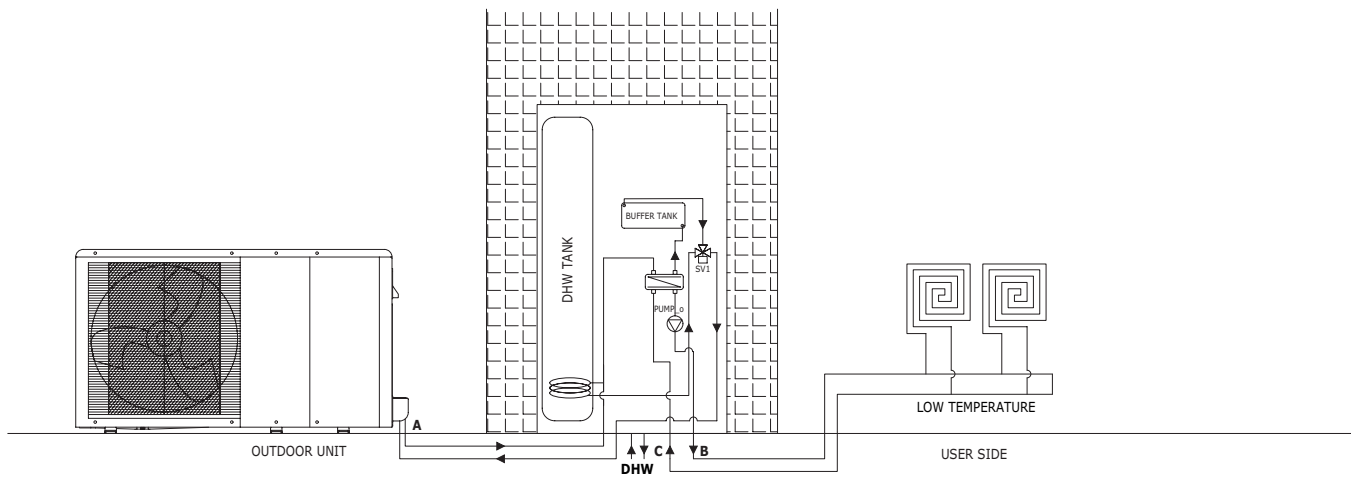

Glycol H₂O kit

EASYIN - Standard unit

DAAGN0001 REV02
DATA/DATE 13/01/2021

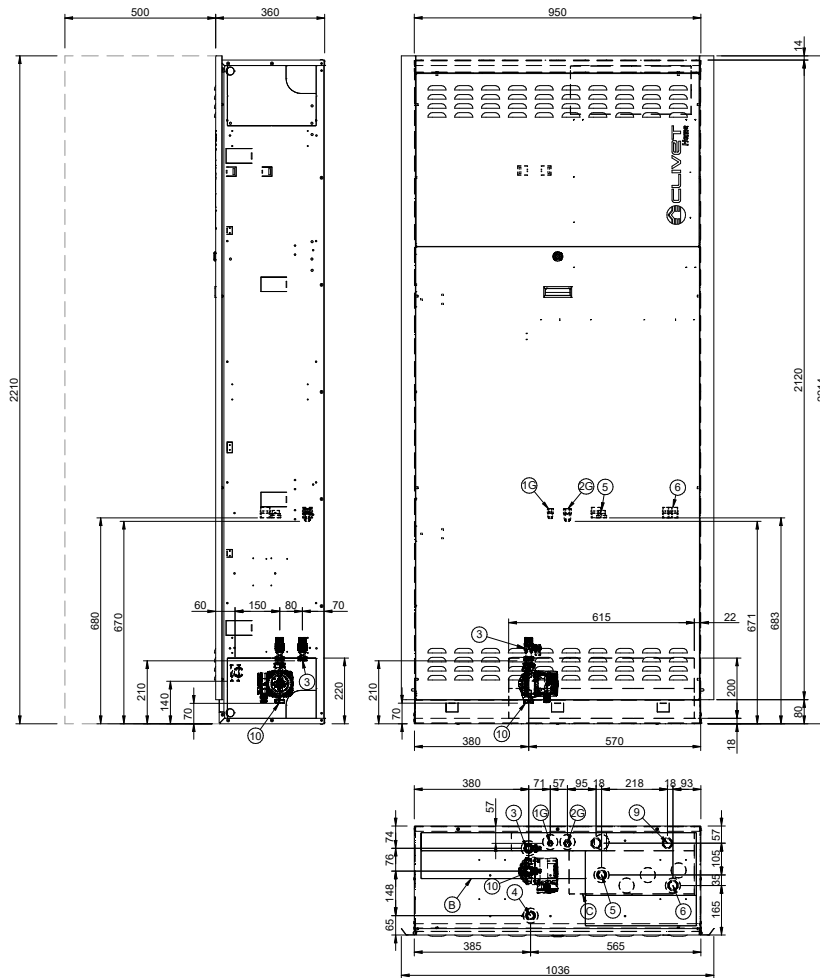

1. (G) Refrigerant line connection (Liquid) 3/8" SAE
 2. (G) Refrigerant line connection (Gas) 5/8" SAE
 3. Hot water supply M G3/4"
 4. Water supply system inlet M G3/4"
 5. Supply to system M G 1"
 6. Return from system M G 1"
 9. Condensation drain and valves
 10. DHW circulation M G3/4" G (Option)
- A - Flaps for anchoring on masonry
B - Pre-cut area for piping passage
C - Pre-cut area for coaxial smoke exhaust 100/60 mm. (For Hybrid version only)
- * Functional spaces

SIZE		STD indoor unit	STD additional practical cabinet for system accessories	150 L water tank + STD unit components kit
Operating weight	kg	50	70	205
Shipping weight	kg	47	65	55

The presence of optional accessories may result in significant variation of the weights indicated.

System connections

EASYIN - Solar kit option

DAAGN0001 REV02
DATA/DATE 13/01/2021

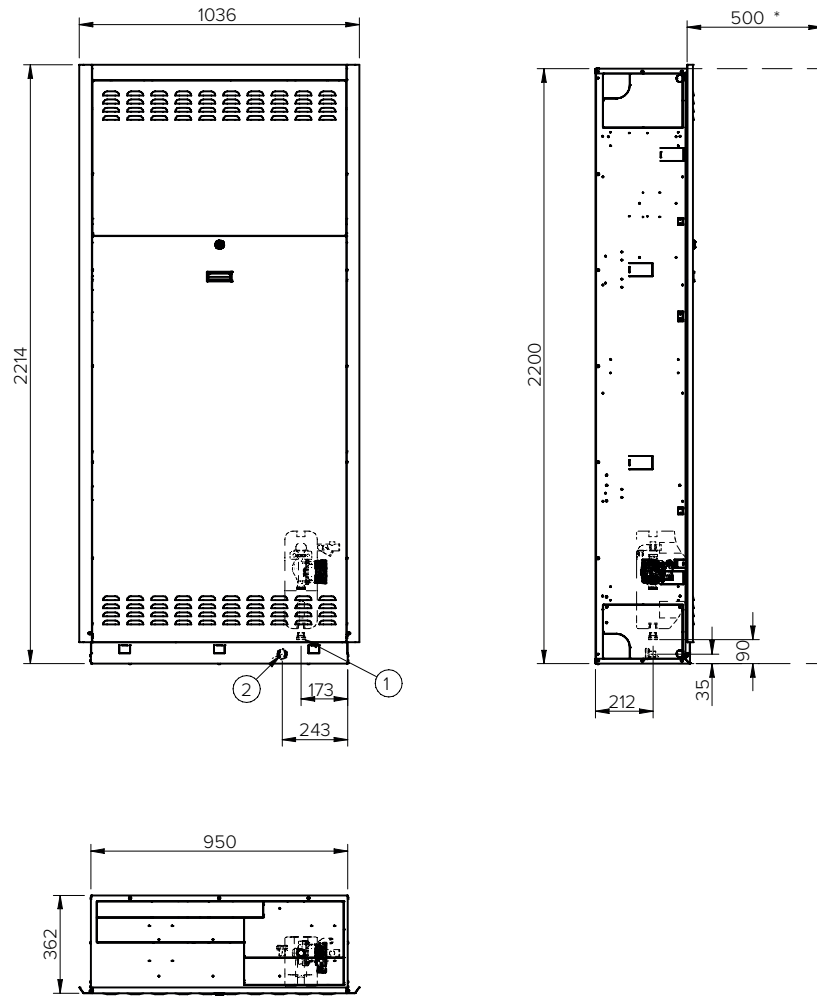

1. Solar system supply connection 3/4"

2. Solar system return connection 3/4"

* Functional spaces

SIZE		KCVEX
Operating weight	kg	8
Shipping weight	kg	8

The presence of optional accessories may result in significant variation of the weights indicated.

ACE50X + ADI50X - 50 L external inertial tank

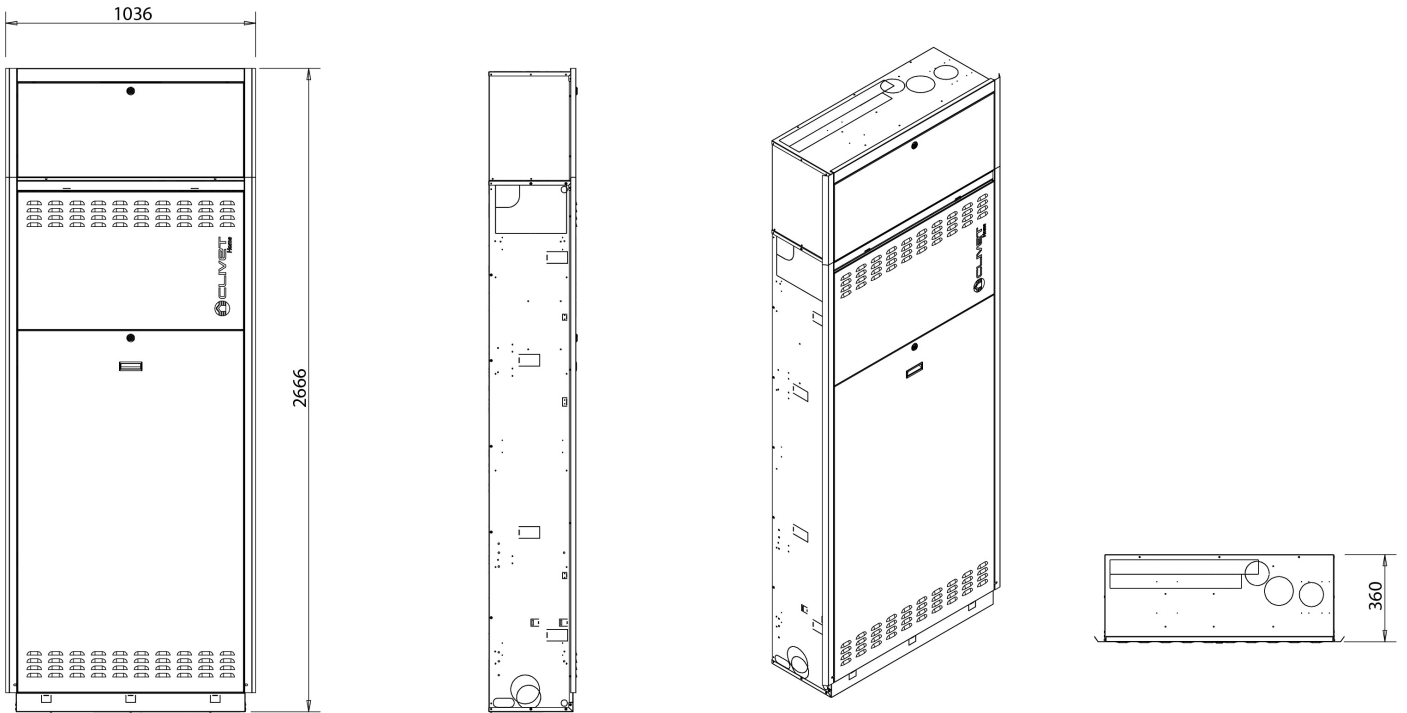

ADI50X - Uncased additional practical cabinet for system accessories for external inertial tank

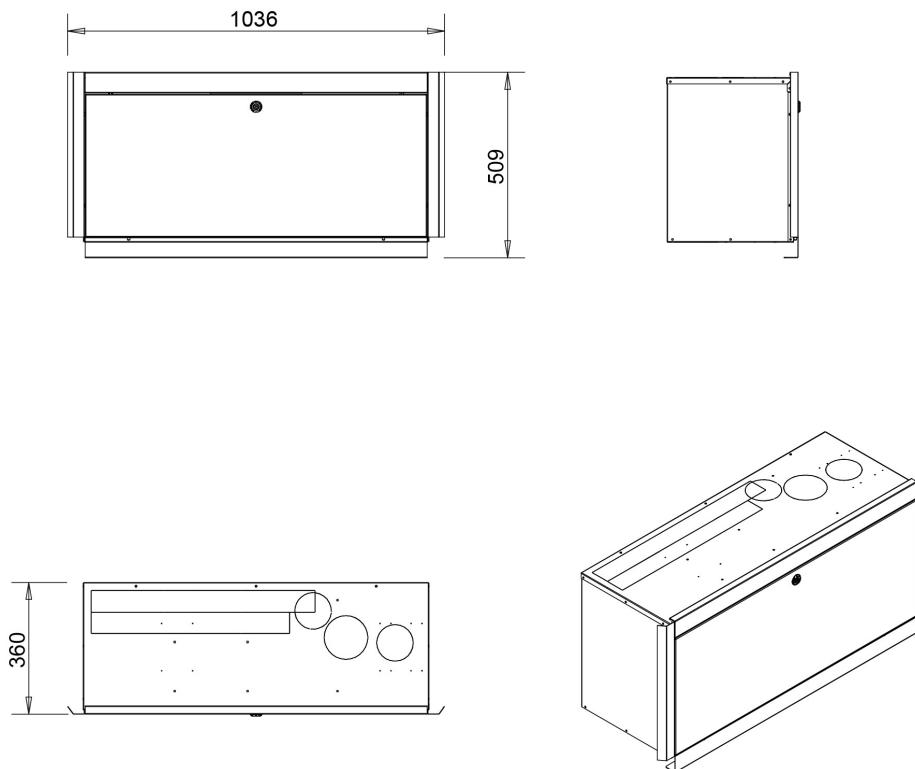

Dimensional drawings

ACSA150X + ADIAX - 150L external additional DHW tank

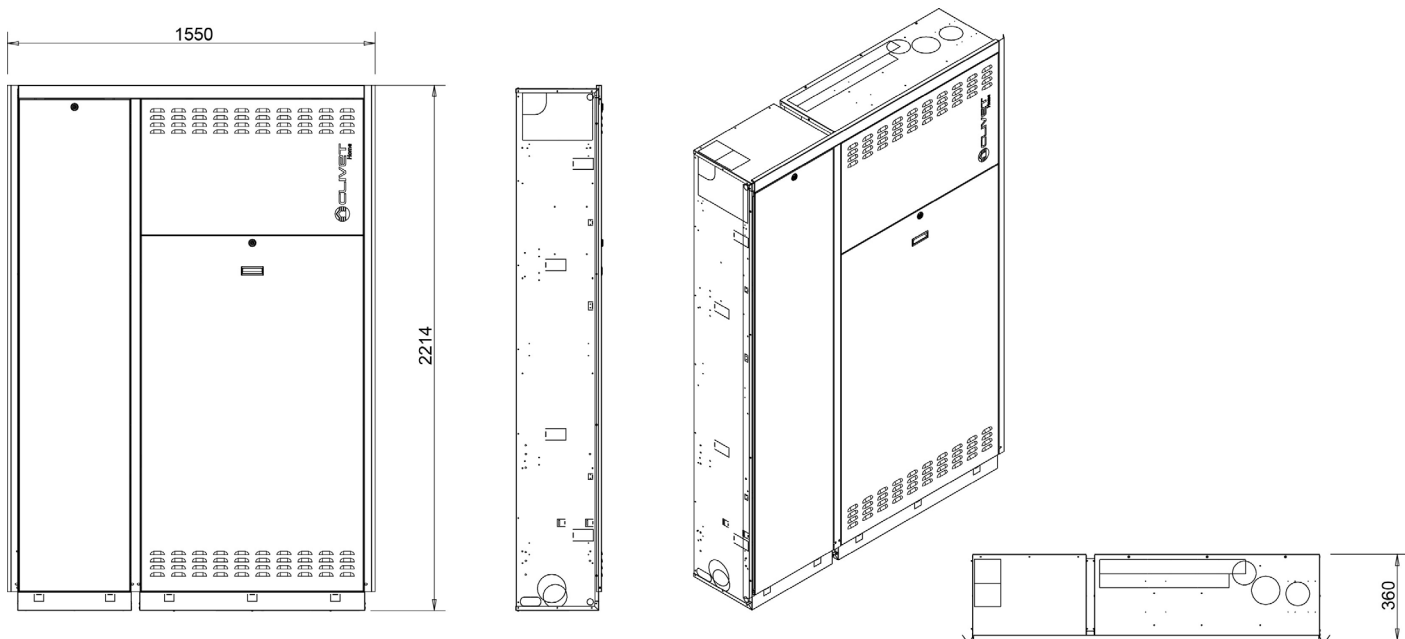

ADIAX - Uncased additional practical cabinet for system accessories for additional DHW tank

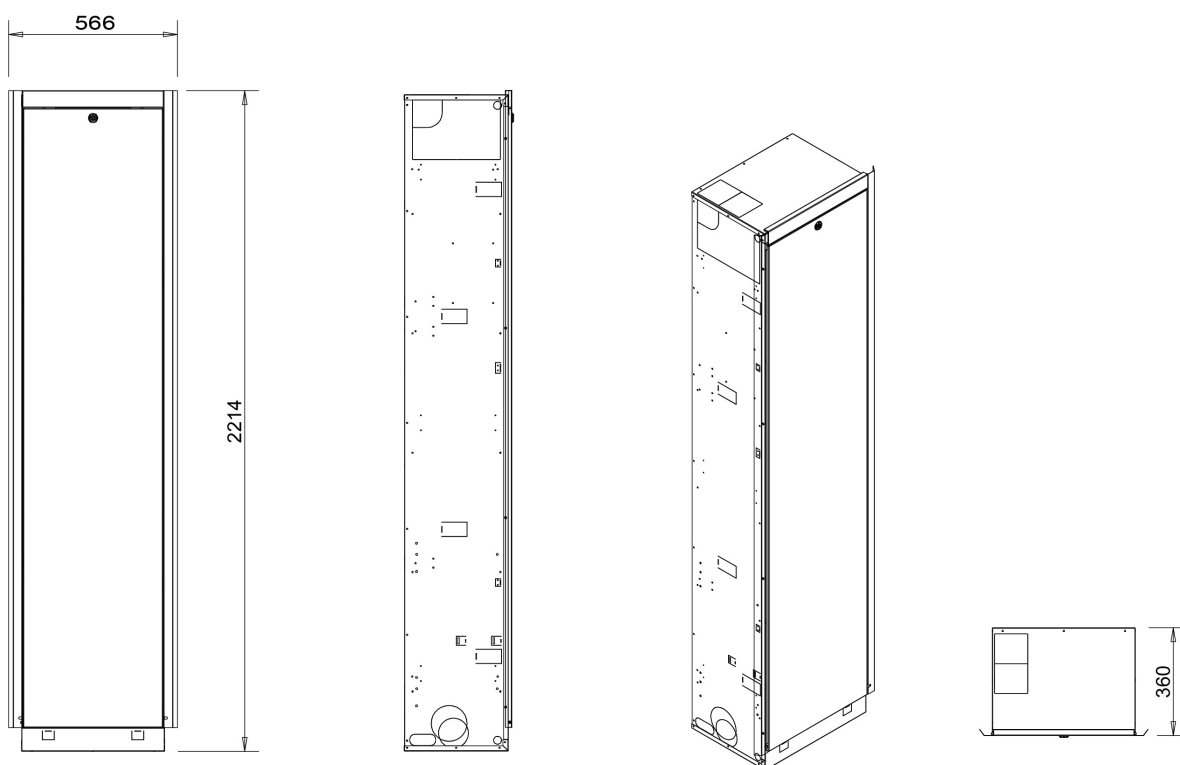

EASYIN - BOILER KIT OPTION

DAAGN0001 REV02
DATA/DATE 13/01/2021

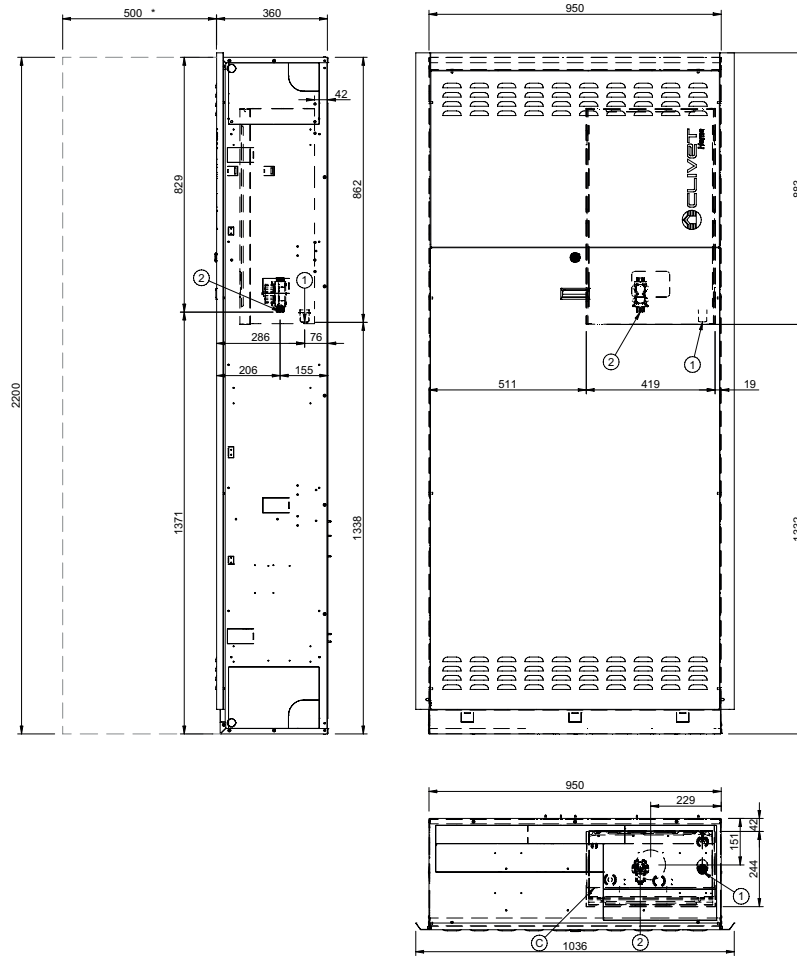

- 1. Boiler condensation drain
- 2. Boiler supply gas inlet
- C - Pre-cut area for smoke exhaust (For Hybrid version only)
- * Functional spaces

SIZE	HYFE24	
Operating weight	kg	40
Shipping weight	kg	40

The presence of optional accessories may result in significant variation of the weights indicated.

Dimensional drawings

PETN00006

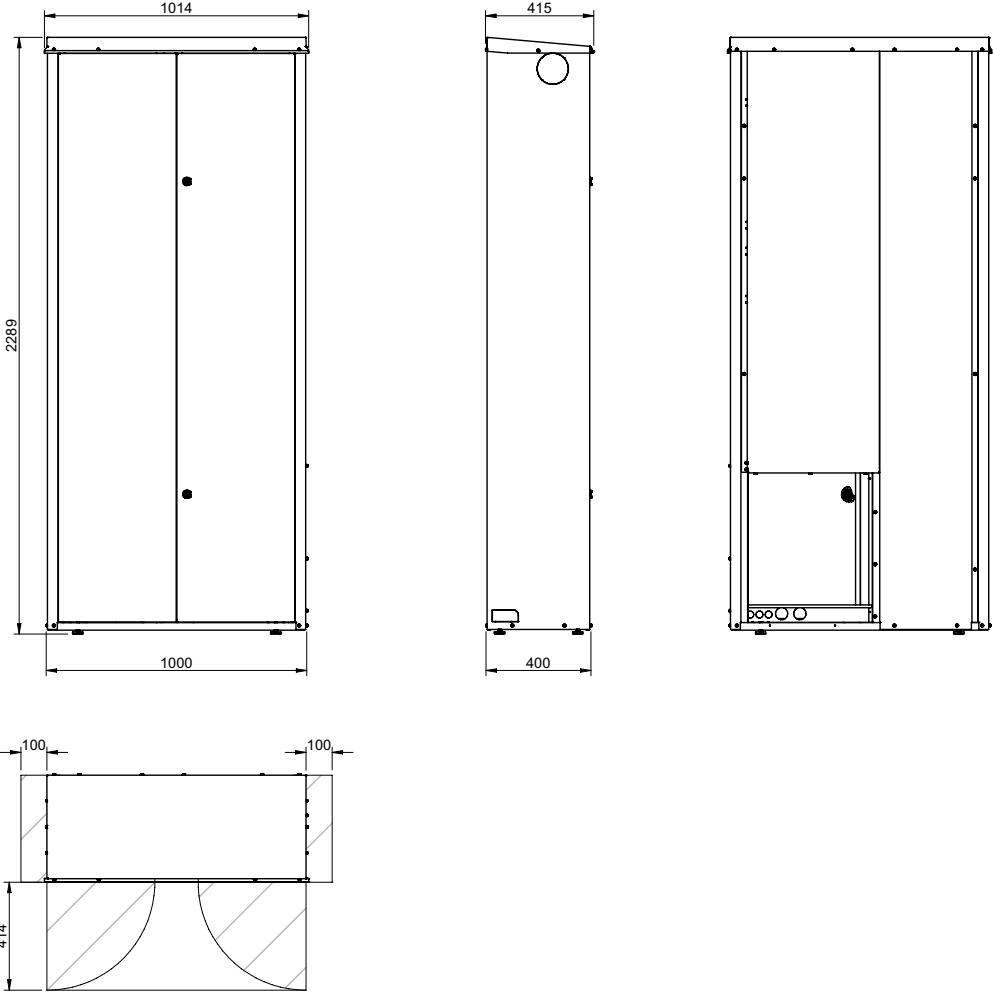

PETN00008

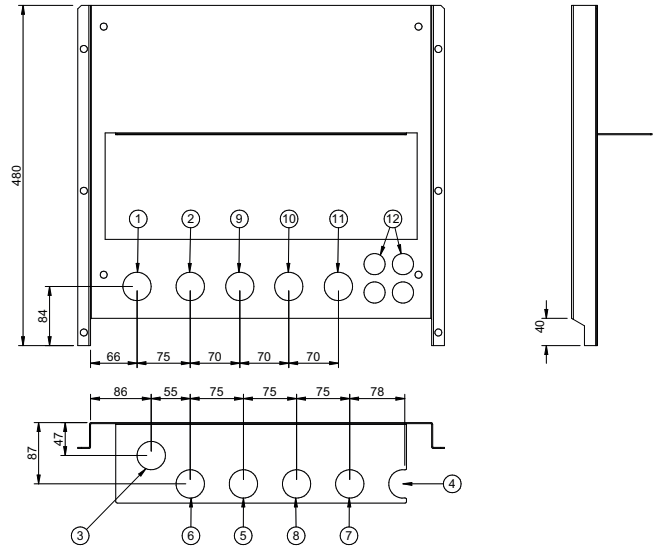
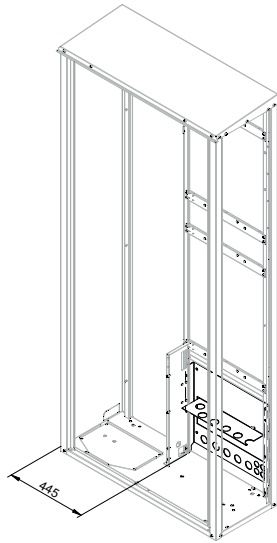
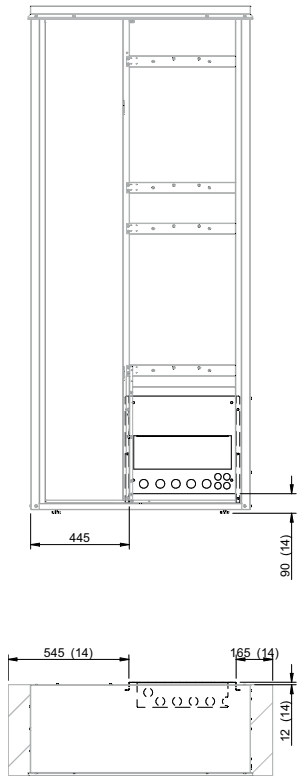

1. Domestic hot water outlet
2. Mains inlet
3. Return to the outdoor unit
4. Supply from outdoor unit
5. Return from system use zone 1
6. Supply from system use zone 1
7. Return from system use zone 2
8. Supply from system use zone 2
9. DHW recirculation circuit input
10. Return from solar system
11. Supply from solar system
12. Power input
13. Unit control keyboard
14. Standard unit functional spaces

Page intentionally left blank

FOR 35 YEARS WE HAVE BEEN OFFERING
SOLUTIONS TO ENSURE SUSTAINABLE
COMFORT AND THE WELL-BEING OF
PEOPLE AND THE ENVIRONMENT

www.clivet.com

MideaGroup
humanizing technology

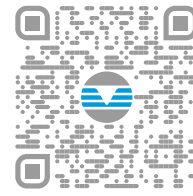

sale and assistance

(Valid from: 2024 - (revision 00/2024
BT24G050GB-00



CLIVET S.p.A.

Via Camp Lonc 25, Z.I. Villapaiera 32032 - Feltre (BL) - Italy

Tel. +39 0439 3131 - info@clivet.it

CLIVET GMBH

Hummelsbütteler Steindamm 84,
22851 Norderstedt, Germany
Tel. +49 40 325957-0 - info.de@clivet.com

Clivet Group UK LTD

Units F5 & F6 Railway Triangle,
Portsmouth, Hampshire PO6 1TG
Tel. +44 02392 381235 -
Enquiries@Clivetgroup.co.uk

CLIVET LLC

Office 508-511, Elektrozavodskaya st. 24,
Moscow, Russian Federation, 107023
Tel. +7495 6462009 - info.ru@clivet.com

CLIVET MIDEAST FZCO

Dubai Silicon Oasis (DSO) Headquarter Building,
Office EG-05, P.O Box-342009, Dubai, UAE
Tel. +9714 3208499 - info@clivet.ae

Clivet South East Europe d.o.o.

Jarušćica 9b
10000, Zagreb, Croatia
Tel. +3851 222 8784 - info.see@clivet.com

CLIVET France SAS

6 Allée Kepler,
77420 Champs-sur-Marne
France
mail: info.fr@clivet.com
Tel: +33 1 88 60 99 40

Clivet Airconditioning Systems Pvt Ltd

Office No.501 & 502,5th Floor, Commercial -I,
Kohinoor City, Old Premier Compound, Off LBS
Marg, Kirool Road, Kurla West, Mumbai
Maharashtra 400070, India
Tel. +91 22 30930200 - sales.india@clivet.com