

*Two section air-water heat pump  
for heating, cooling and DHW  
production*

## SPHERA EVO 2.0 Box SQKN-YEE 1 BC + MiSAN-YEE 1 S 2.1-8.1

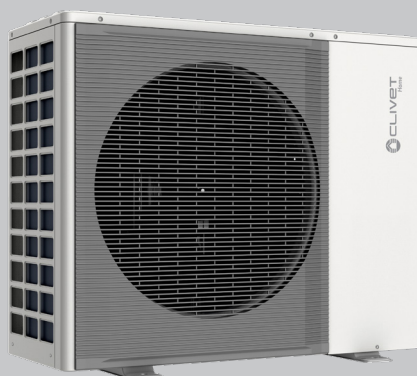

TECHNICAL BULLETIN



SIZE	2.1	3.1	4.1	5.1	6.1	7.1	8.1
HEATING CAPACITY KW	4,32	6,18	8,30	10,9	12,13	14,51	16,01
COOLING CAPACITY KW	4,55	6,44	8,10	10,00	12,06	13,79	14,84

## Pagina

---

3	Features and benefits
4	Standard unit technical specifications
6	Built-in option
7	Accessories separately supplied
13	General technical data
30	Refrigerant connections
31	Electrical connections
32	Auxiliary and hybrid version heat sources
34	System connections
37	Data for the UNI/TS 11300 calculation
42	Main functions
44	EuroSwitch Function
45	Management of units in cascade
46	Dimensional drawings



Clivet is taking part in the EUROVENT certification programme  
The products concerned appear in the certified products list of the EUROVENT [www.eurovent-certification.com](http://www.eurovent-certification.com) site.

# Features and benefits

SPHERA EVO 2.0 is a specialised autonomous heat pump system for single- and multi-family homes with medium/low and high power consumption.

Is an air-water heat pump system for cooling and producing/storing domestic hot water.

The SPHERA EVO 2.0 system is composed of a latest generation high efficiency outdoors moto-condensing unit connected via refrigerant connections to an indoors unit.

It is the second generation of heat pumps for residential use.

## SPHERA EVO 2.0 Box

- Box Version
- Integrated 3-way valve for DHW
- Compact dimensions
- Class A+++ Low temperature
- Built-in WiFi for connection to the dedicated APP
- Also available in the hybrid version with 24 kW or 34 kW gas boiler



## SPHERA EVO 2.0 Tower

- Tower Version
- Two volumes of DHW 190 and 250-litres
- Class A++ Average temperature
- Class A+ Domestic hot water production
- Built-in WiFi for connection to the dedicated APP
- Also available in the hybrid version with 24 kW or 34 kW gas boiler

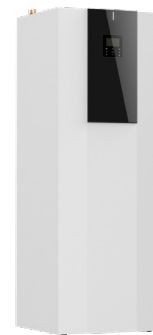

## SPHERA EVO 2.0 Invisible

- Version for built-in installation
- 150-litre DHW storage can be expanded up to 300-litres
- Compact dimensions for easy installation in walls
- Also available in the hybrid version with 24 kW or 34 kW gas boiler
- Built-in WiFi for connection to the dedicated APP
- Also available with aesthetic outdoor cabinet



## SPHERA EVO 2.0 - BOX - Indoor unit

### Zinc-Magnesium frame

Supporting frame in Zinc-Magnesium panelling, excellent mechanical characteristics and high resistance to corrosion over time.

### Panelling

External panelling in zinc-magnesium sheet, with white paint in RAL 9003 to ensure better resistance to corrosion. Panels that can be easily removed to allow full access to internal components.

### Internal exchanger

Direct expansion heat exchanger with INOX AISI 316 stainless steel braze-welded plates. With low refrigerant content and high exchange surface, complete with external anti-condensation thermal insulation 10 mm thick in sintered expanded polypropylene.

### Hydronics module

- DC primary circulate pump, vary at variable flow
- Safety flow switch for water flow
- 3-way switching valve of installation or domestic hot water
- Water side safety valve 3bar
- Magnetic dirt separator
- Sistem purge valve
- 12 liter system expansion tank, 1 bar pre-charge
- ABS drain pan
- 15 litre inertial storage tank

### Electrical panel

The electrical panel is located inside the unit and is easily accessible thanks to removable panel. Moreover, a LED on the front panel is connected to check the operating status of the unit.

The capacity section includes:

- main power supply terminals.

Coloured keypad for:

- remote microprocessor control with single-area thermostat function;
- BMS management;
- daily, weekly temperature set point and start-up/shutdown scheduler;
- anti-legionella function scheduling;
- management busters two zones;
- solar thermal management;
- management for auxiliary heaters;
- antifreeze protection water side;
- no water flow-rate protection with flow switch;
- remote interface terminal with graphic display;
- cascade operation.

Inside the electrical panel there are:

- T5 temperature probe for temperature control in DHW storage tanks (length 4.5 m and 6 mm bulb);
- T1B temperature probe for low temperature area control in the 2 area kit (length 4.5 m and 6 mm bulb);
- T1 temperature probe for external boiler connection kit (1.6 m length and 6 mm bulb).
- Wi-Fi per connessione all'APP dedicata alla gestione dell'unità.

The immersion heater in the DHW storage tanks must not exceed 4 kW.

### Standard unit kit:

- Mesh filter for system water
- Copper gas reduction for 4-6 kW external unit connection
- Unit connection fittings
- Key and torx insert for opening and closing unit panels
- Cover cap for remotely controlled keypad
- 1 x quick-action coupling spring
- 1 x expansion tank connection gasket
- 1 x O-ring
- 1x grease tube
- T-connector

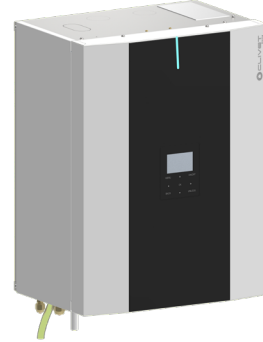

# Standard unit technical specifications

## SPHERA EVO 2.0 - Outdoor unit

### Zinc-Magnesium frame

High strength frame for outstanding durability and excellent mechanical characteristics.

### Panelling

Outer panelling made of Zinc-Magnesium sheet metal painted with pantone warm gray 2C to ensure superior corrosion resistance. Each panel can be easily removed to allow full access to internal components.

### Rotary DC inverter compressor

Inverter controlled rotary hermetic compressor for constant modulation of the power supplied according to actual needs, ensuring high seasonal efficiency. With a motor protection device for overheating, overcurrents and excessive temperatures of the supply gas. It is installed on anti-vibration mounts and it is equipped with oil charge. The compressor is wrapped by a sound-absorbing hood, that reduces its sound emissions. A guard heater with automatic insertion prevents the refrigerant from diluting the oil when the compressor stops.

### EC inverter fan

Axial fan with variable speed control and sickle shaped blades in ABS resin. It is directly coupled to the electronically controlled motor (IP23), which, thanks to brushless technology and the particular power supply, increases its lifespan and reduces consumption. The fan is housed in an aerodynamically shaped nozzle to increase efficiency and minimise noise. It is also fitted with anti-intrusion grid.

### External exchanger

Direct expansion finned coil exchanger made with copper pipes mechanically expanded to better adhere to the fin collar. It has a large surface area to improve heat exchange and reduce defrosting in the interest of seasonal efficiency. The fins are made of aluminium with hydrophilic treatment which facilitates the elimination of condensate, further improving defrosting.

### Refrigerant circuit

The refrigeration circuit includes:

- Electronic expansion valve
- 4-way cycle inversion valve
- Liquid separator in extraction
- Mechanical filters
- Low pressure pressure switch
- High pressure pressure switch

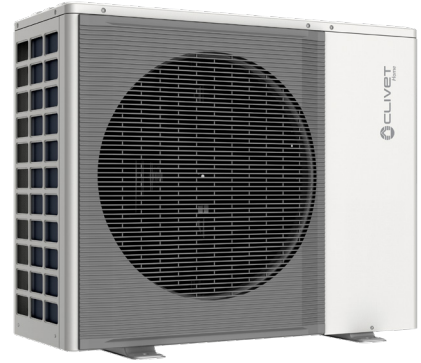

## **EH024 Integration electric heater**

**EH6** Integration electric heater in STAINLESS STEEL with 2-3 and 4 kW single-phase or 6-9 kW three-phase capacities.  
**EH9**

The electric heater can operate both for the system and for the production of domestic hot water in two different modes:

- as an integration, when the heat pump capacity is not enough to fulfil the required set point;
- as a safety element if the heat pump fails;

⚠ The additional electric heater is not an accessory supplied separately, but a construction configuration.

⚠ The configuration with additional electric heater excludes the external boiler connection kit.

⚠ Selection of the additional three-phase electric heater changes the voltage of the indoor unit only. The outdoor unit remains with single phase power supply.

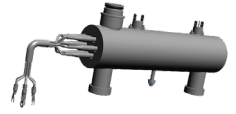

## **1PUM Single pump with larger available head**

Configuration involving a pump with a head higher than the standard one.

The circulator, with a head of 9.5 m and a direct current power supply, has a variable flow rate and adapts perfectly to the internal logic of the unit.

⚠ Single pump with increased head is not an accessory supplied separately, but a construction configuration.



# Accessories separately supplied

## KIRE2HX - 2 zones: external kit, high temperature KIRE2HLX 2 zones: external kit, high temperature + low temperature

Distribution module for 2-zone heating systems with compact design (402 mm x 250 mm x h525 mm) and ample versatility for different types of installation.

Kit composed of:

- 1 collector / Black painted separator;
- 2 circulator;
- 1 sliding temperature mixing valve (only for the kit KIRE2HL);
- 1 EPP insulation (front and rear);
- 1 threaded disc with hermetic sealing cap,
- 1 lower anti-rotation jig;
- 1 support bracket module;
- 1 probe for mixed circuit temperature management

For the technical data of the hydraulic head of the pumps, please refer to the dedicated section in the HYDRAULIC DATA chapter.

## KCSX Secondary circuit kit (1-litre circuit breaker + pump)

The single-zone kit consists of a DIX hydraulic separator combined with a high efficiency pump, all inside a box for easy installation. Allows interaction between the primary circuit circulator and the secondary circuit circulator. Furthermore, the separator also has the function of a deaerator. With the following benefits and advantages:

- makes the connected hydraulic circuits independent;
- ensures effective operation of the secondary circulator that provides the hydraulic demand of air conditioning systems
- air extraction system;
- thermally insulated black EPP
- zone manifold connection kit

The kit is comprised of:

- 1 1-litre circuit breaker;
- 2 copper pipes;
- 1 circulator;
- closing plates



Dimensions:  
Length 457 mm  
Height 457 mm  
Depth 133 mm

## DIMENSIONAL

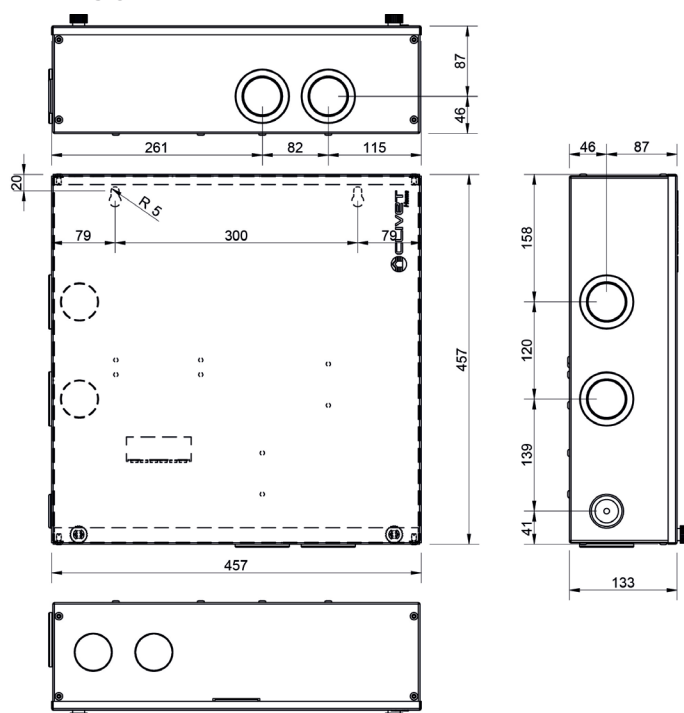

## DI50-2X

### 50-litre circuit breaker

Technical 50-litre storage tank with the function of a hydraulic separator and inertial tank ensures effective operation of the secondary circulators that provide the hydraulic demand of air conditioning systems. With the possibility of connecting two zones.

Technical data:

Circuit breaker diameter 380 mm

Circuit breaker height 933 mm

Connections 1"1/4 F

Max temperature 95 °C

Max pressure 6 bar

Circuit breaker material S235JR steel

Circuit breaker capacity 57 litres

Circuit breaker weight 25 kg

Insulation material Polyurethane foam

Insulation thickness 40 mm

Energy class B

Specific heat loss 0.76 W/K

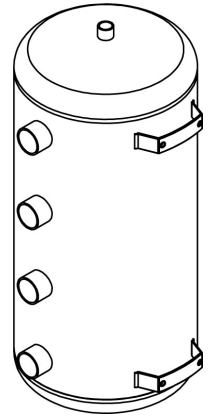

The kit is supplied with brackets for wall mounting.

### DIMENSIONAL

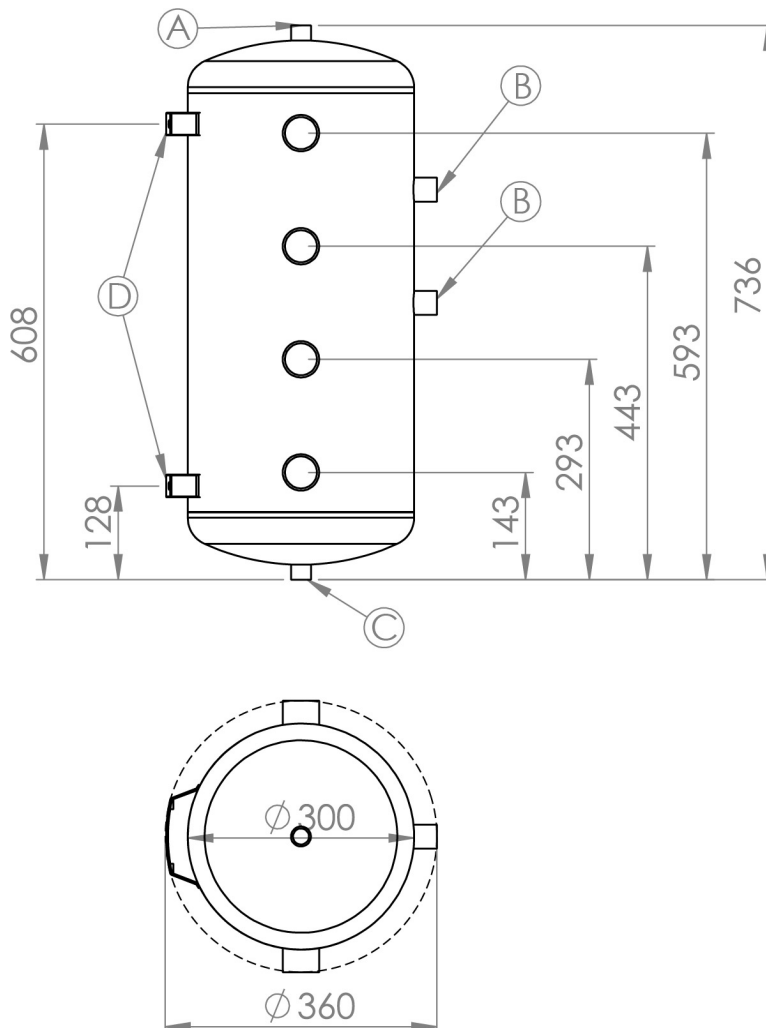

# Accessories separately supplied

<b>ACS200X</b>	<b>200-liter domestic hot water storage tank</b>
<b>ACS300X</b>	<b>300-liter domestic hot water storage tank</b>
<b>ACS500X</b>	<b>500-liter domestic hot water storage tank</b>

Carbon steel tanks with internal vitrification treatment according to DIN 4753-3 and UNI 10025. Complete with magnesium anodic protection, inspection flange, electric heater.

All the tanks have an external insulation in 70 mm rigid polyurethane which allows to reduce heat losses to a minimum and increase efficiency.

		<b>ACS200X</b>	<b>ACS300X</b>	<b>ACS500X</b>
Capacity	[litri]	196	273	475
Diameter	[mm]	640	640	790
Height	[mm]	1215	1615	1705
Surface of exchanger	[m <sup>2</sup> ]	1,5	1,8	2,2
Surface of solar exchanger	[m <sup>2</sup> ]	\	\	\
Max pressure of hot water	[bar]	10	10	10
Tank energy class	[-]	B	B	B
Storage dispersion	[W]	51	63	80
Thermal dispersions	[W/K]	1,13	1,40	1,78
Electric heater	[kW]	2,0	2,0	2,0

Data according to DIN 4708 / EN 12897 / en 15332

<b>SCS08X</b>	<b>0.8 m<sup>2</sup> solar exchanger for flange installation</b>
<b>SCS12X</b>	<b>1.2 m<sup>2</sup> solar exchanger for flange installation</b>

The kit is available in two sizes: 0.8 m<sup>2</sup> when combined with the 200 and 300 litre tank and 1.2 m<sup>2</sup> when combined with the 500 litre tank.

The kit is comprised of:

- tin-plated finned copper coil
- plastic cover

## **ACI40X** 40L system inertial storage tank

Inertial storage tank to be installed outside the unit. Extremely compact, supplied with air vents and support brackets for wall installation. Suitable for all SPHERA EVO 2.0 sizes, it facilitates operation and helps to fulfil the heat requirement, guaranteeing optimal modulation.

It can be installed next to or behind the unit, as shown in the figure.

Kit consisting of:

- 1 40-litre ST37.1 steel storage tank for ACI40X
- 1 2-metre flexible hose
- Extremely compact:  
LENGTH: 440 mm  
DEPTH: 220 mm  
HEIGHT: 887 mm
- Maximum working temperature: 100 °C
- Maximum operating pressure: 6 bar
- Thermally-isolated with EPP 40 g/l
- Insulation thickness 30 mm
- Automatic air vent



## **HTC2WX**    **White HID-TConnect<sup>2</sup> chronothermostat for temperature control**

Chronothermostat for semi-recessed installation with temperature probe. The thermostat is able to manage the request for the heat pump and allows control of the system with the App (Clivet Home Connect) or voice assistant (Amazon Alexa or Google Home). The thermostat can be combined with a radio receiver for managing the request of terminal units or radiant systems, the mode change of the heat pump, or the systems with double set-point.



## **SWCX**    **SwitchConnect radio receiver**

Radio receiver for HID-TConnect, for managing the request of terminal units or radiant systems, the heat pump mode change or the double set-point.

Technical specifications:

- functions: radio receiver for use with HID-TConnect
- combinable thermostats: max 6
- frequency: 2.4GHz
- transmission distance: max 30m (in buildings) / max 100m (in open range)
- contacts: 2 relays (voltage-free)
- power supply: 95÷290V / 47÷440Hz
- operation temperature: 0÷40°C
- operation humidity: 20÷80% RH
- dimensions: 125x78x30.5mm



# Accessories separately supplied

**T1BX** **DHW temperature probe and additional heating source at 10 m**  
**T1B30X** **DHW temperature probe and additional heating source at 30 m**

NTC water temperature probe with 10 m or 30 m cable.

The probe can be used to detect temperatures:

Tsolar: solar thermal circuit

T1: boiler or external electric heater

T5: DHW tank

Tw2: mixed zone 2

Tbt1/Tbt2: hydraulic separator

 *The unit is equipped with a T1BX probe as standard.*

**DTX** **Auxiliary drain pan**

**Outdoor unit**

The base plate of the outdoor unit is fitted with a drain for the condensate produced during the winter phase in the defrosting period. This can help (not guarantee) condensate flow correctly into the relevant drains.

To ensure the condensate is drained correctly, in the various operating conditions it is mandatory to use the auxiliary condensate drain pan with drainage to be connected to the drain trap, according to the relevant technical standards and regulations in force.

An anti-freeze heater is also included in the drain pan. It prevents the condensate produced from freezing when the outdoor temperature drops below zero.



**APAVX** **Kit of antivibration mounts for floor installation**

The antivibration mounts for floor installation reduce the vibrations of the compressor during its operation. They are secured to the feet of the base plate.



**ASTFX** **Kit of antivibration mounts for wall bracket installation**

The antivibration mounts reduce the vibrations of the compressor during its operation. They are secured to the wall support brackets



## KSIPX

### Kit with wall fixing brackets

Wall fixing bracket for outdoor unit, adjustable, in galvanised steel painted with polyester powders for outdoor use.



## VDACSX

### Thermostatic switching valve for DHW

The thermostatic switching valve is used in the DHW circuit.

It is designed to divert the water from the DHW storage tank directly to the utility as the water temperature is suitable for use. If the temperature is not adequate for direct use, the switching valve ensures the water passes inside the boiler which, thanks to instant production, guarantees continuous supply.

1 1/4 "M connections.

Body in anti-dezincification alloy. Chromium-plated.

PSU shutter.

Stainless steel springs.

EPDM sealing elements.

Maximum inlet temperature 100 °C.

Adjustment range: 38÷52°C

Accuracy: ± 2°C

Max (static) working pressure: 10 bar

Max (dynamic) working pressure: 5 bar

Default calibration: 40°C

Minimum range for steady operation: 4 l/min



⚠️ Reductions for connections of different diameters are the responsibility of the client

# General technical data

## Performance

SIZE			2.1	3.1	4.1	5.1	6.1*	7.1*	8.1*
<b>HEATING</b>									
<b>Air 7 °C - Water 35 °C</b>									
Nominal Heating capacity / Max	1	kW	4,32 / 6,26	6,18 / 7,41	8,30 / 9,11	10,09 / 10,3	12,13 / 14,60	14,51 / 15,5	16,01 / 16,80
Total power input	1	kW	0,80	1,19	1,56	2,01	2,42	3,09	3,52
COP	1	-	5,42	5,21	5,31	5,01	5,00	4,70	4,55
Water flow-rate	1	l/s	0,21	0,30	0,41	0,49	0,57	0,67	0,75
Nominal available pressure	1	kPa	31,2	36,5	33,1	31,0	25,7	31,7	22,6
Maximum available pressure	1	kPa	69 95	62 90	47 83	31 76	70	55	39
<b>Air -7 °C - Water 35 °C</b>									
Nominal Heating capacity / Max	2	kW	4,17 / 6,25	6,05 / 6,97	7,33 / 8,35	8,20 / 9,30	10,49 / 13,85	12,23 / 14,09	13,43 / 14,33
Total power input	2	kW	1,32	2,01	2,27	2,67	3,36	4,33	4,90
COP	2	-	3,16	3,00	3,23	3,07	3,13	2,82	2,74
Water flow-rate	2	l/s	0,22	0,29	0,34	0,40	0,56	0,62	0,70
Nominal available pressure	2	kPa	35,0	39,8	34,0	31,7	65,8	63,1	47,7
Maximum available pressure	2	kPa	69 94	64 91	58 88	49 84	71	63	49
<b>Air 7 °C - Water 45 °C</b>									
Nominal Heating capacity / Max	3	kW	4,16 / 5,96	6,03 / 7,13	8,22 / 8,98	10,01 / 10,30	12,30 / 14,50	14,00 / 15,70	16,01 / 16,60
Total power input	3	kW	1,06	1,57	2,08	2,59	3,24	3,84	4,45
COP	3	-	3,93	3,83	3,95	3,86	3,80	3,65	3,60
Water flow-rate	3	l/s	0,19	0,30	0,39	0,49	0,60	0,67	0,76
Nominal available pressure	3	kPa	32,3	36,4	34,9	31,0	51,6	41,8	21,7
Maximum available pressure	3	kPa	70 95	63 90	51 85	31 76	65	55	38
<b>Air 7 °C - Water 55 °C</b>									
Nominal Heating capacity / Max	4	kW	4,08 / 5,74	5,94 / 6,90	7,50 / 7,80	9,60 / 9,72	12,07 / 13,90	13,85 / 14,50	16,00 / 16,20
Total power input	4	kW	1,36	1,93	2,35	3,10	3,89	4,53	5,52
COP	4	-	3,00	3,07	3,19	3,10	3,10	3,05	2,90
Water flow-rate	4	l/s	0,12	0,18	0,23	0,29	0,36	0,41	0,48
Nominal available pressure	4	kPa	22,7	33,4	31,2	33,6	14,1	16,5	17,4
Maximum available pressure	4	kPa	70 98	70 96	69 94	63 91	90	105	80
<b>COOLING</b>									
<b>Air 35 °C - Water 18 °C</b>									
Nominal Cooling capacity / Max	5	kW	4,55 / 6,88	6,44 / 7,65	8,10 / 11,13	10,00 / 12,03	12,06 / 15,02	13,79 / 15,30	14,84 / 16,38
Total power input	5	kW	0,75	1,23	1,58	2,10	3,00	3,73	4,07
EER	5	-	6,08	5,24	5,12	4,77	4,02	3,70	3,65
Water flow-rate	5	l/s	0,22	0,32	0,38	0,48	0,60	0,63	0,71
Nominal available pressure	5	kPa	34,9	34,8	34,6	10,6	13,1	16,3	15,1
Maximum available pressure	5	kPa	69 94	61 89	51 85	32 76	65	61	48
<b>Air 35 °C - Water 7 °C</b>									
Nominal Cooling capacity / Max	6	kW	4,26 / 6,14	6,25 / 6,39	7,46 / 7,94	8,67 / 9,10	11,16 / 11,80	11,72 / 12,86	12,88 / 14,2
Total power input	6	kW	1,22	2,02	2,24	2,94	4,29	5,04	5,80
EER	6	-	3,50	3,09	3,33	3,09	2,75	2,55	2,45
Water flow-rate	6	l/s	0,20	0,29	0,36	0,43	0,54	0,59	0,64
Nominal available pressure	6	kPa	35,8	36,1	34,3	36,8	18,1	20,3	25,1
Maximum available pressure	6	kPa	70 95	64 91	56 87	43 82	74	67	60

1. User side entering/leaving water temperature 30/35 °C, source side air 7 °C (U.R. = 85% Heat power data, Total power input and COP in accordance with EN 14511:2022.
2. User side entering/leaving water temperature 30/35 °C, source side air -7 °C Heat power data, Total power input and COP in accordance with EN 14511:2022.
3. User side entering/leaving water temperature 40/45 °C, source side air 7 °C (U.R. = 85% Heat power data, Total power input and COP in accordance with EN 14511:2022.
4. User side entering/leaving water temperature 47/55 °C, source side air 7 °C (U.R. = 85% Heat power data, Total power input and COP in accordance with EN 14511:2022.
5. User side entering/leaving water temperature 18/23 °C, source side air 35 °C Heat power data, Total power input and COP in accordance with EN 14511:2022.
6. User side entering/leaving water temperature 7/12 °C, source side air 35 °C Heat power data, Total power input and COP in accordance with EN 14511:2022.

All data calculated with zero elevation gain and equivalent length of 7m.

SIZE			2.1	3.1	4.1	5.1	6.1*	7.1*	8.1*
<b>ERP</b>									
<b>Clima Average High temperature Heat pumps</b>									
Nominal power	7	kW	4	6	7	9	12	13	13
SCOP	7	-	3.32	3.54	3.72	3.73	3.56	3.52	3.48
Generator energy class	7	-	A++	A++	A++	A++	A++	A++	A++
$\eta_s$	7	%	130	138	146	146	139	138	136
System energy class	7	-	A++	A++	A++	A++	A++	A++	A++
$\eta_s$	7	%	135	143	151	151	144	143	141
<b>Clima Average Low temperature Heat pumps</b>									
Nominal power	8	kW	5	6	8	10	12	14	16
SCOP	8	-	5,13	5,15	5.32	5.27	5.00	4.91	4.89
Generator energy class	8	-	A+++	A+++	A+++	A+++	A+++	A+++	A+++
$\eta_s$	8	%	202	203	210	208	196	193	193
System energy class	8	-	A+++	A+++	A+++	A+++	A+++	A+++	A+++
$\eta_s$	8	%	207	208	215	213	201	198	198
<b>Average climatic conditions - Heat pump for application with Fan coil</b>									
Nominal power	9	kW	4	6	7	9	12	13	14
SEER	9	-	5,09	5,42	5.95	6.01	5.16	5.10	4.87
Generator energy class	9	-	A+++	A+++	A+++	A+++	A+++	A+++	A+++
$\eta_s$	9	%	201	214	235	238	203	201	192
<b>Heat pump for Domestic Hot Water application</b>									
Load profile declared	10	-	L	XL	L	XL	L	XL	XL
$\eta_{wh}$	10	%	120	123	120	123	116	125	124
Sanitary water energy class	10	-	A+	A+	A+	A+	A+	A+	A+

- The product is conforming with the European ErP Directives, which includes Commission Delegated Regulation (EU) N. 811/2018 and Commission Delegated Regulation N. 813/2013, Clima Average, Medium temperature 47/55 °C
- The product is conforming with the European ErP Directives, which includes Commission Delegated Regulation (EU) N. 811/2018 and Commission Delegated Regulation N. 813/2013, Clima Average, Low temperature 30/35 °C
- The product is conforming with the European ErP Directives, which includes Commission Delegated Regulation (EU) N. 811/2018 and Commission Delegated Regulation N. 813/2013, Clima Average, Low temperature 12/7 °C
- Dati secondo EN 16147:2017

All data calculated with zero elevation gain and equivalent length of 7 m.

## Construction - Outdoor unit

SIZE			2.1	3.1	4.1	5.1	6.1	7.1	8.1
<b>Characteristics</b>									
Compressor	Twin Rotary								
Refrigerant	R32								
Refrigerant charge	kg		1.50	1.50	1.65	1.65	1.84	1.84	1.84
GWP	$t_{CO_2}$		675	675	675	675	675	675	675
Equivalent tons of CO2 (*)	$t_i$		1.02	1.02	1.11	1,11	1.24	1.24	1.24
Oil charge	l		0,46	0,46	0,46	0,46	1,10	1,10	1,10
Type of fan	Assiale								
Standard air flow rate	$m^3/h$		2770	2770	4030	4030	4060	4060	4060
Outdoors unit sound pressure at 1 metre	1	dB(A)	42	44	45	47	50	51	53
Sound power	1	dB(A)	55	57	58	60	63	64	66
<b>Dimensions</b>									
Operation (L x P x A)	mm		986x426x712	986x426x712	1104x523x866	1104x523x866	1104x523x866	1104x523x866	1104x523x866
Packaging (L x P x A)	mm		1065x485x800	1065x485x800	1180x560x890	1180x560x890	1180x560x890	1180x560x890	1180x560x890
Operation weight 230M / 400TN	2	kg	58	58	77	77	96/112	96/112	96/112
Shipping weight 230M / 400TN	2	kg	64	64	88	88	110/125	110/125	110/125

- Sound pressure level determined using the intense metric method (UNI EN ISO 9614-2). Data referred to the following full load conditions: Heating - utility side water inlet/outlet 47/55 °C, air source side 7°C. Cooling - utility side water inlet/outlet 12/7 °C, air source side 35 °C.
  - Power supply 220-240V ~ 50Hz / Power supply 380-415V 3N~ 50Hz.
- (\*) It contains fluorinated greenhouse gases.

# General technical data

## Construction - Indoor unit

SIZE			A	B
<b>Characteristics</b>				
Maximum system pressure		bar	3,0	3,0
System expansion tank	1	l	12	12
Preload expansion tank		bar	1,0	1,0
System water connections		inch	1"	1"
<b>Dimensions</b>				
Operation (L x P x A)		mm	547 x 386 x 604	547 x 386 x 604
Packaging (L x P x A)		mm	720 x 600 x 550	720 x 600 x 550
Operation weight		kg	50	53
Shipping weight		kg	58	61

1. Sufficient volume up to a maximum of 60 litres of system water content.

## Hydraulic data - Indoor unit + Outdoor unit

SIZE			2.1	3.1	4.1	5.1	6.1	7.1	8.1
			A	A	A	A	B	B	B
<b>Characteristics</b>									
Minimum system water content	1	l	40	40	40	40	40	40	40
Minimum water flow rate allowed		l/s	0,16	0,16	0,16	0,16	0,16	0,16	0,16
Maximum water flow rate allowed		l/s	0,61	0,61	0,61	0,61	0,92	0,92	0,92

1. Consider the water content of the area with less volume

## Configuration compatibility table SPHERA EVO 2.0 Box

INDOOR UNIT	SQKN-YEE 1 BC A			SQKN-YEE 1 BC B		INTEGRATION ELECTRIC HEATER		
	Pump	Std	1PUM	Std		EH024	EH6	EH9
<b>OUTDOOR UNIT</b>								
MiSAN-YEE 1 S 2.1		✓	✓	-		✓	✓	✓
MiSAN-YEE 1 S 3.1		✓	✓	-		✓	✓	✓
MiSAN-YEE 1 S 4.1		✓	✓	-		✓	✓	✓
MiSAN-YEE 1 S 5.1		✓	✓	-		✓	✓	✓
MiSAN-YEE 1 S 6.1		-	-	✓		✓	✓	✓
MiSAN-YEE 1 S 7.1		-	-	✓		✓	✓	✓
MiSAN-YEE 1 S 8.1		-	-	✓		✓	✓	✓

## Condensing boiler technical data

MODEL				FE 24.4	FE 33.4	
<b>Heating capacity</b>						
Nominal heating capacity (Qn)	-	Maximum	[kW]	24,5	34,8	
		Minimum	[kW]	4,8	5,0	
Heating capacity (Pn)	60/80 °C	Maximum	[kW]	24,0	34,0	
		Minimum	[kW]	4,7	4,9	
	30/50 °C	Maximum	[kW]	26,0	37,0	
		Minimum	[kW]	5,2	5,4	
Performance	60/80 °C	Maximum	%	97,8	97,7	
		Minimum	%	97,6	97,2	
	30/50 °C	Maximum	%	106,1	106,2	
		Minimum	%	107,3	107,1	
	30% di Pn	-	%	109,7	109,7	
	Boiler water content	-	-	[l]	3,4	4,3
Operating pressure	PMS	Maximum	[bar]	3	3	
	-	Minimum	[bar]	0,8	0,8	
Expansion tank	Volume	-	[l]	8	10	
	Preload	-	[bar]	0,8	0,8	
<b>ACS performances</b>						
Nominal heating capacity (Qnw)	-	Maximum	[kW]	28,5	34,8	
		Minimum	[kW]	4,7	5,0	
Heating capacity	-	Maximum	[kW]	28,0	34,0	
		Minimum	[kW]	4,7	4,8	
Specific flow rate	ΔT=25 °C	-	[l/min]	16,1	19,5	
	ΔT=30 °C	-	[l/min]	13,4	16,2	
	ΔT=45 K	-	[l/min]	8,9	10,8	
DHW production in continuous operation	ΔT=40 K	-	[l/min]	10,0	12,1	
	ΔT=35 K	-	[l/min]	11,5	13,9	
	ΔT=30 K	-	[l/min]	13,4	16,2	
	ΔT=25 K	-	[l/min]	16,1	19,5	
Water temperature		Maximum	[°C]	65	65	
		Minimum	[°C]	40	40	
Operating pressure	PMW	Maximum	[bar]	9	9	
	-	Minimum	[bar]	0,3	0,3	
<b>ErP data</b>						
Seasonal efficiency <i>Medium climate</i>	Heating	ηs	%	94	94	
		Energy class	-	A	A	
	DHW	ηwh	%	85	85	
		Energy class	-	A	A	
		DHW profile	-	XL	XXL	
Sound power level		Lwa	[dB(A)]	49	52	
<b>Thermal losses and smoke discharge</b>						
Chimney losses	burner ON 80/60 °C	Pmax	%	2,00	2,10	
		Pmin	%	2,00	2,90	
	burner ON 50/30 °C	Pmax	%	1,40	1,40	
		Pmin	%	1,00	1,00	
Smoke temperature	80/60 °C	Pmax	[°C]	66	67	
		Pmin	[°C]	64	62	
	50/30 °C	Pmax	[°C]	52	53	
		Pmin	[°C]	44	45	
	Smoke flow rate	-	Pmax	[g/s]	11,2	16
		-	Pmin	[g/s]	2,3	2,4
Nitrogen oxide (NOX) emissions		Class	-	6	6	
		-	[mg/kWh]	35	33	

# General technical data

## Boilers for centralised systems

MODEL			UC 70.2	UC 115.2	UC 200.2	
<b>Heating Performance</b>						
Modulation ratio	-	-	-	1: 7	1: 5.75	1: 10
Nominal heat capacity (Qn)	-	Maximum	[kW]	67.5	115.0	199.0
		Minimum	[kW]	9.6	20.0	20.0
Heating capacity (Pn)	60/80 °C	Maximum	[kW]	65.7	111.5	194.8
		Minimum	[kW]	9.1	19.2	19.1
	30/50 °C	Maximum	[kW]	68.7	120.0	205.2
		Minimum	[kW]	10.3	21.8	21.1
Efficiency	60/80 °C	Maximum	%	97.3	97.1	97.9
		Minimum	%	94.9	95.9	95.6
	30/50 °C	Maximum	%	101.7	104.6	103.1
		Minimum	%	107.6	108.8	105.4
	30% of Pn	-	%	107.3	107.3	108.9
	Combustion efficiency	Reduced load	-	%	98.3	98.3
Nominal load		-	%	97.4	97.7	98.0
Water content	-	-	[l]	3.9	9.0	22.0
Operating pressure	PMS	Maximum	[bar]	6	6	6
	-	Minimum	[bar]	0.5	0.5	0.5
<b>ErP data</b>						
Seasonal eff.	Heating	$\eta_s$	%	93	92	93
Average climate		Energy class	-	A	A	A
Sound power level	-	Lwa	[dB(A)]	63	-	-
<b>Thermal losses and discharge of flue gas</b>						
Casing losses	burner ON	Qn	%	0.09	0.7	0.14
		Qmin	%	3.44	2.69	2.60
Flue loss	burner ON	Pmax	%	2.62	2.29	2.00
		Pmin	%	1.66	1.87	1.80
Flue gas temperature ( $T_f - T_a$ )		Pmax	[°C]	51.3	46.6	40
		Pmin	[°C]	34	36	34
Flue gas flow rate	-	Pmax	[g/s]	111.4	184.6	319.57
		Pmin	[g/s]	15.9	34.3	34.3
Nitrogen oxide (NOX) emissions	-	Class	-	6	6	6
		-	[mg/kWh]	59	47	68

## Electrical data

### Outdoor unit

SIZE		2.1	3.1	4.1	5.1	6.1	7.1	8.1
<b>Power supply 220-240V ~ 50Hz</b>								
F.L.A. - Full load current at max admissible conditions	A	10.0	11.8	15.0	16.4	24.5	25.9	27.7
F.L.I. - Full load power input at max admissible conditions	kW	2.20	2.60	3.30	3.60	5.40	5.70	6.10
M.I.C - Maximum inrush current	A	10.0	11.8	16,7	16.4	24.5	25.9	27.7
<b>Power supply 380-415V 3N ~ 50Hz</b>								
F.L.A. - Full load current at max admissible conditions	A	-	-	-	-	8.20	8.70	9.30
F.L.I. - Full load power input at max admissible conditions	kW	-	-	-	-	5.40	5.70	6.10
M.I.C - Maximum inrush current	A	-	-	-	-	8.20	8.70	9.30

### Indoor unit

SIZE		A	B
<b>Power supply 220-240V ~ 50Hz</b>			
F.L.A. - Full load current at max admissible conditions	A	0,50	0,90
F.L.I. - Full load power input at max admissible conditions	kW	0,10	0,20
M.I.C - Maximum inrush current	A	0,50	0,90

Power supply 220-240V ~ 50Hz +/-10%

The units are conforming with the prescriptions of European Standards CEI EN 60335 and EN 60335-2-40

(\*) The electrical consumptions relating to the electric heater refer to that in the DHW storage tank.

**⚠ Important:** when rating the unit, check that the absorptions are conforming to the utility contract in the country of installation

### Unit configured with oversized pump

SIZE		1PUM
<b>Power supply 220-240V ~ 50Hz</b>		
F.L.A. - Current absorbed by the unit with increased head circulator	A	0,7
F.L.I. - Power input of the unit with increased head circulator	kW	140

Power supply 220-240V ~ 50Hz +/-10%

The units are conforming with the prescriptions of European Standards CEI EN 60335 and EN 60335-2-40

Data to be added to the values of the standard indoor unit.

### Integration electric heaters - EH024/EH6/EH9

SIZE		2 KW	4 KW
<b>Power supply 220-240V ~50Hz</b>			
F.L.A. - Full load current at max admissible conditions	A	10,1	20,2
F.L.I. - Full load power input at max admissible conditions	kW	2	4

Power supply 220-240V ~50Hz +/- 10%

Size 2kW and 4kW available only for indoor unit A, size 3kW available only for indoor unit B

SIZE		6 kW	9 kW
<b>Power supply 380-415V 3N ~50Hz</b>			
F.L.A. - Full load current at max admissible conditions	A	10,1	15,2
F.L.I. - Full load power input at max admissible conditions	kW	6	9

Power supply 380-415V 3N ~50Hz +/- 6%

\*Data to be added to the values of the standard unit without DHW electric heater

**⚠** The additional electric heater is not an accessory supplied separately, but a construction configuration.

# General technical data

## External 2 zone kit

SIZE	KIRE2HX - KIRE2HLX	
<b>Power supply 220-240V ~50Hz</b>		
F.L.A. - Full load current at max admissible conditions	A	0,6
F.L.I. - Full load power input at max admissible conditions	kW	120

Power supply 220-240V ~ 50Hz +/-10%

The units are conforming with the prescriptions of European Standards CEI EN 60335 and EN 60335-2-40

Data to be added to the values of the standard indoor unit.

## Single zone kit

SIZE	KCSX	
<b>Power supply 220-240V ~50Hz</b>		
F.L.A. - Full load current at max admissible conditions	A	0,3
F.L.I. - Full load power input at max admissible conditions	kW	60

Power supply 220-240V ~ 50Hz +/-10%

The units are conforming with the prescriptions of European Standards CEI EN 60333

Data to be added to the values of the standard indoor unit.

## Storage tanks for domestic hot water

SIZE		ACS200X	ACS300X	ACS500X
<b>Power supply 220-240V ~50Hz</b>				
F.L.A. - Current absorbed by the electric heater	A	10,1	10,1	10,1
F.L.I. - Power input of the electric heater	kW	2	2	2
M.I.C. Unit maximum starting current	A	10,1	10,1	10,1

Power supply 220-240V ~ 50Hz +/-10%

The units are conforming with the prescriptions of European Standards CEI EN 60335 and EN 60335-2-40

Data to be added to the values of the standard indoor unit.

The tanks are supplied with immersed electric heater.

## Integration condensing boiler

MODEL		FE 24.4	FE 33.4	
<b>Power supply 220-240V ~50Hz</b>				
F.L.A. - Full load current at max admissible conditions	-	W	0,4	0,5
F.L.I. - Full load power input at max admissible conditions	-	-	82	99
Power supply fuse	-	-	3,15	3,15
Protection rating	IP	-	X4D	X4D

Power supply 220-240V ~ 50Hz +/-10%

The units comply with the requirements of European standards EN 60335-1 and EN 60335-2-40

Data to be added to standard indoor unit values.

## Sound levels outdoor unit

### Standard mode

SIZE	Sound power level								Sound pressure level	Sound power level
	Octave band (Hz)									
	63	125	250	500	1000	2000	4000	8000	dB(A)	dB(A)
<b>2.1</b>	46	49	49	52	52	46	37	27	42	55
<b>3.1</b>	49	48	50	55	53	48	39	30	44	57
<b>4.1</b>	36	51	53	56	55	49	44	30	45	58
<b>5.1</b>	37	56	53	57	57	51	47	36	47	60
<b>6.1</b>	44	53	54	60	58	55	52	51	50	63
<b>7.1</b>	44	54	55	60	59	57	56	54	51	64
<b>8.1</b>	46	58	57	60	61	59	54	51	53	66

Sound levels refer to units with full load under nominal test conditions. Data referred to the following conditions: entering / leaving exchanger water temperature user side 47/55 °C source side exchanger air inlet 7 °C. The sound pressure level refers to a distance of 1m from the external surface of the units operating in an open field. Noise levels are determined using the tensiometric method (UNI EN ISO 9614-2)

### Silenced mode

SIZE	Sound pressure level	Sound power level
	dB(A)	dB(A)
<b>2.1</b>	40	53
<b>3.1</b>	40	53
<b>4.1</b>	42	55
<b>5.1</b>	42	55
<b>6.1</b>	46	59
<b>7.1</b>	47	60
<b>8.1</b>	48	61

Sound levels refer to units with full load under nominal test conditions. For maximum capacity delivered in silent mode use a correction factor of 0.8. Data referred to the following conditions: entering / leaving exchanger water temperature user side 47/55 °C source side exchanger air inlet 7 °C. The sound pressure level refers to a distance of 1m from the external surface of the units operating in an open field. Noise levels are determined using the tensiometric method (UNI EN ISO 9614-2)

### Super-silenced mode

SIZE	Sound pressure level	Sound power level
	dB(A)	dB(A)
<b>2.1</b>	37	50
<b>3.1</b>	38	51
<b>4.1</b>	39	52
<b>5.1</b>	39	52
<b>6.1</b>	41	54
<b>7.1</b>	41	54
<b>8.1</b>	41	54

Sound levels refer to units with full load under nominal test conditions. For maximum capacity delivered in silent mode use a correction factor of 0,6. Data referred to the following conditions: entering / leaving exchanger water temperature user side 47/55 °C source side exchanger air inlet 7 °C. The sound pressure level refers to a distance of 1m from the external surface of the units operating in an open field. Noise levels are determined using the tensiometric method (UNI EN ISO 9614-2)

## Operating limits

### Cooling

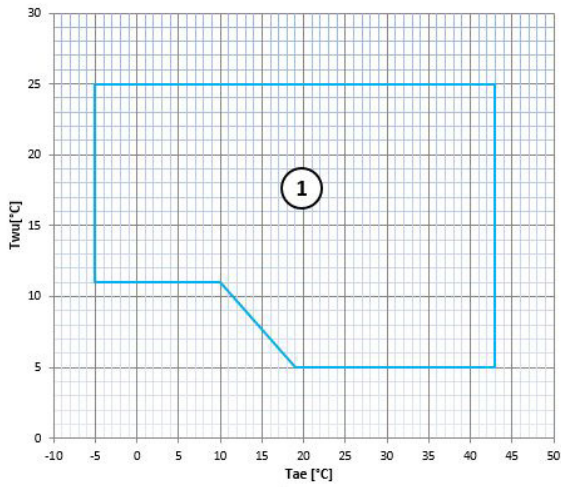

T<sub>wu</sub> [°C] = Exchanger water outlet temperature  
 T<sub>ae</sub> [°C] = Outdoors exchanger air inlet temperature

1. Normal operating range

### Heating

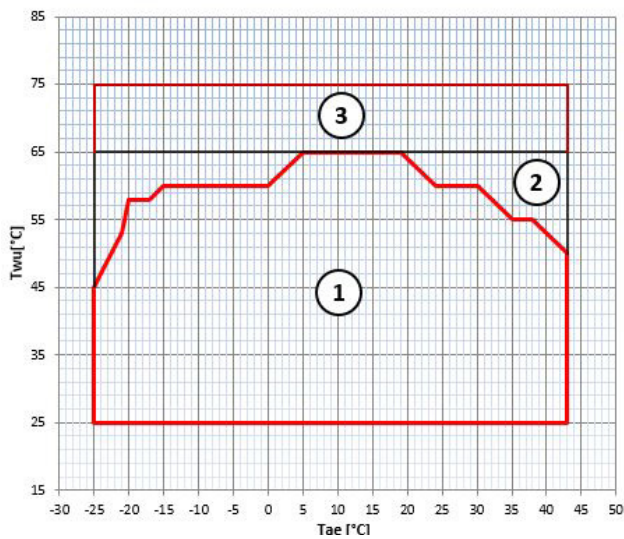

T<sub>wu</sub> [°C] = Exchanger water outlet temperature  
 T<sub>ae</sub> [°C] = Outdoors exchanger air inlet temperature

1. Normal operating range
2. Operating range with additional electric heater option
3. Hybrid system operating range

In the configuration with the integration electric heater, the extension of the limits varies according to the electrical capacity of the electric heater chosen.

\*refer to the main functions chapter for more details on operating limits in DHW mode.

## Available pressure of the standard circulator at the unit A connections

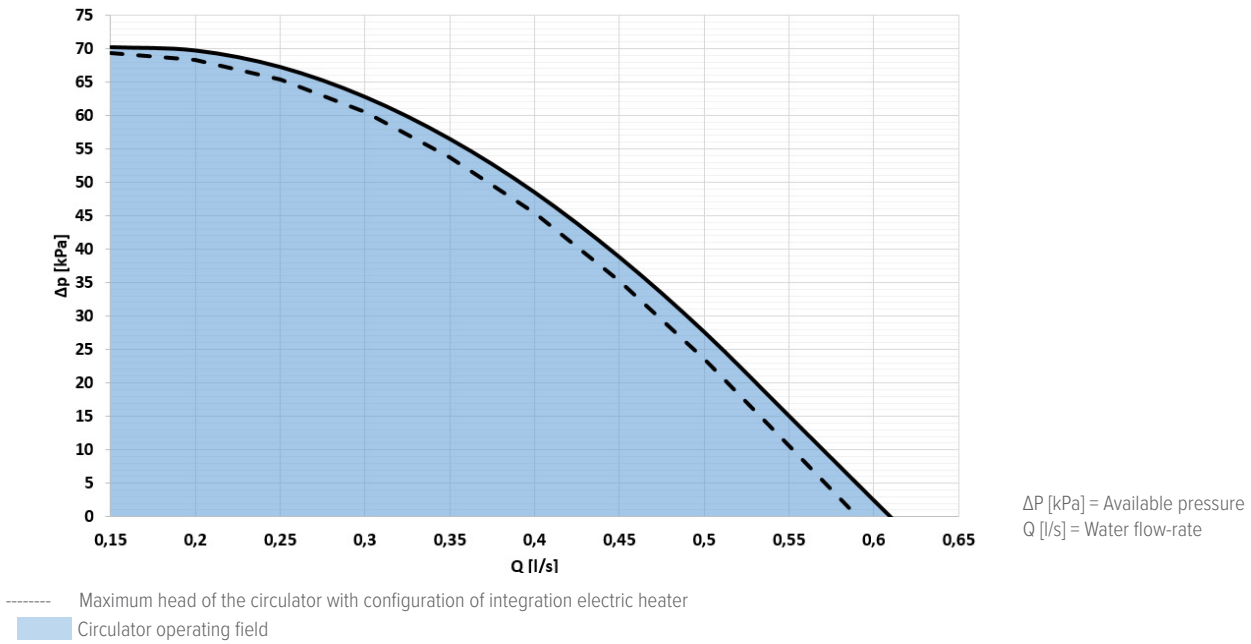

## Head of the circulator with increased pump at the unit A connections

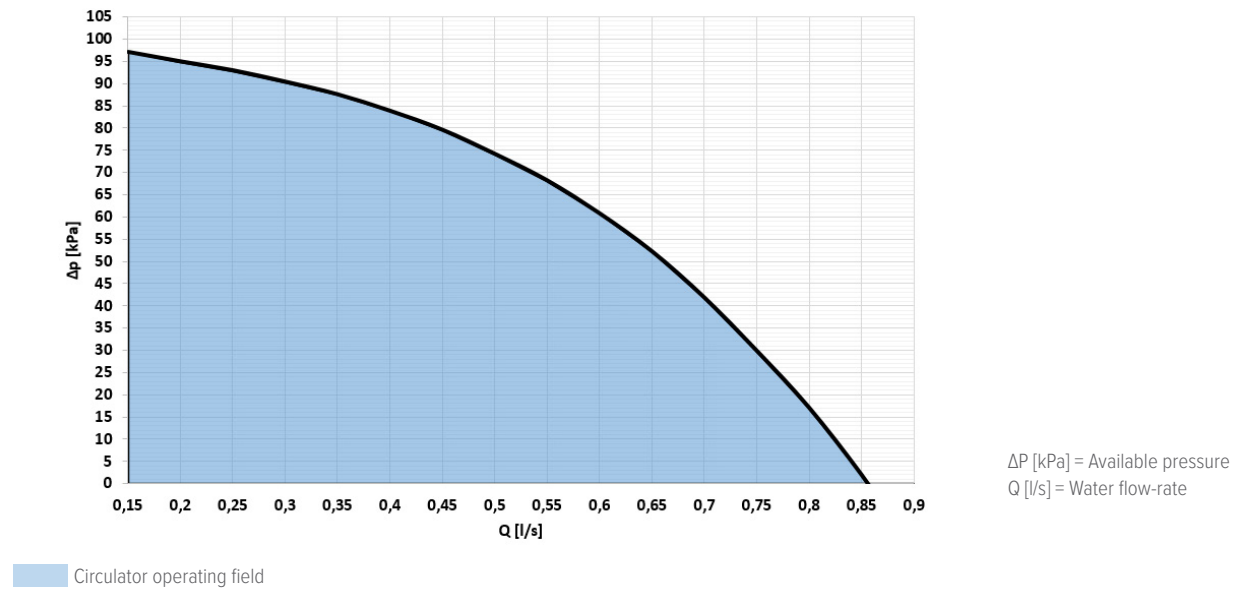

# General technical data

## Head of the circulator with increased pump at the unit B connections

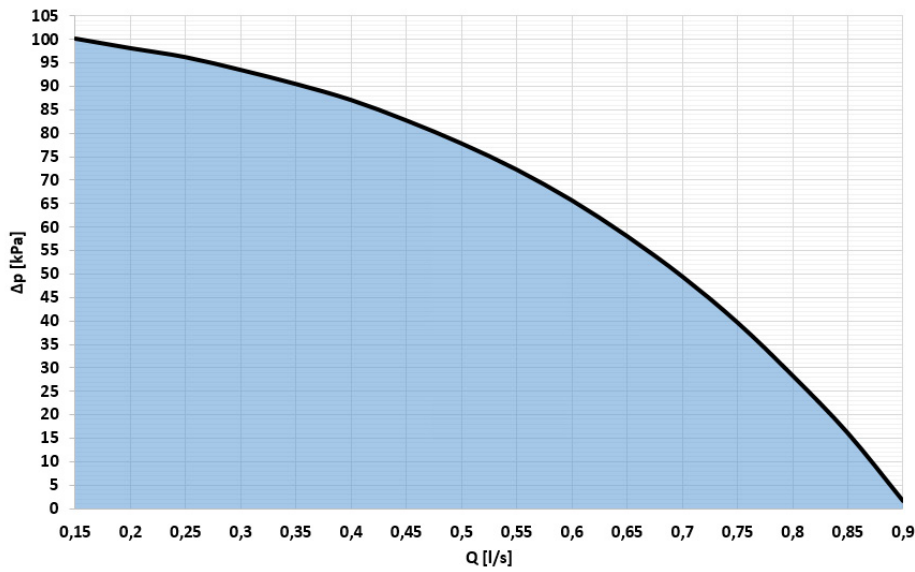

$\Delta p$  [kPa] = Available pressure  
 $Q$  [l/s] = Water flow-rate

----- Maximum head of the circulator with configuration of integration electric heater.  
Circulator operating field

## Available pressure of the circulator GAS BOILER FE 24.4

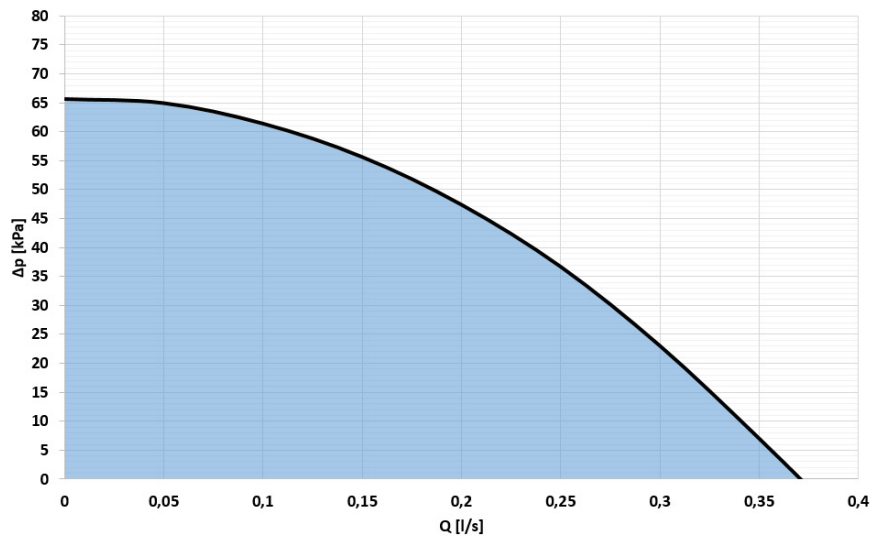

$P_{el}$  [W] = Electrical power input  
 $Q$  [l/s] = Water flow-rate

Circulator operating field

## Available pressure of the circulator GAS BOILER FE 33.4

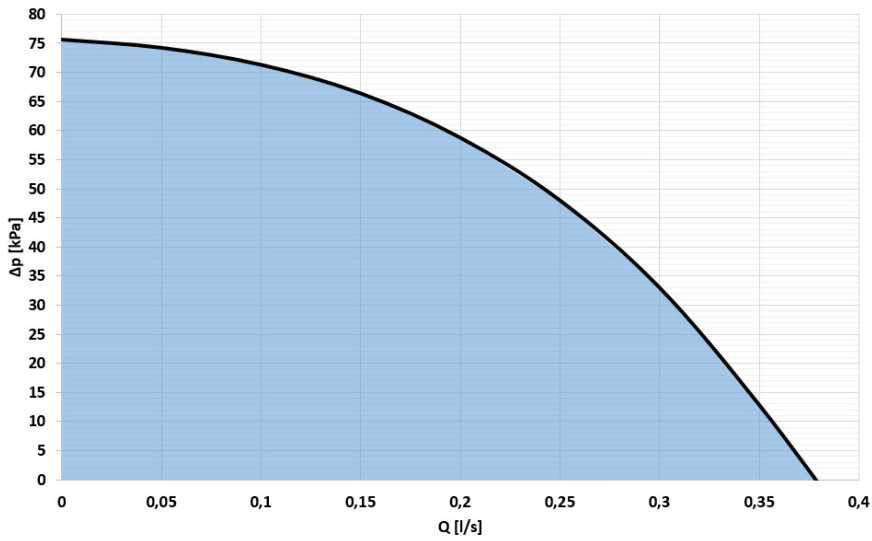

ΔP [kPa] = Available pressure  
Q [l/s] = Water flow-rate

Circulator operating field

## Pressure drop for direct booster system circulator

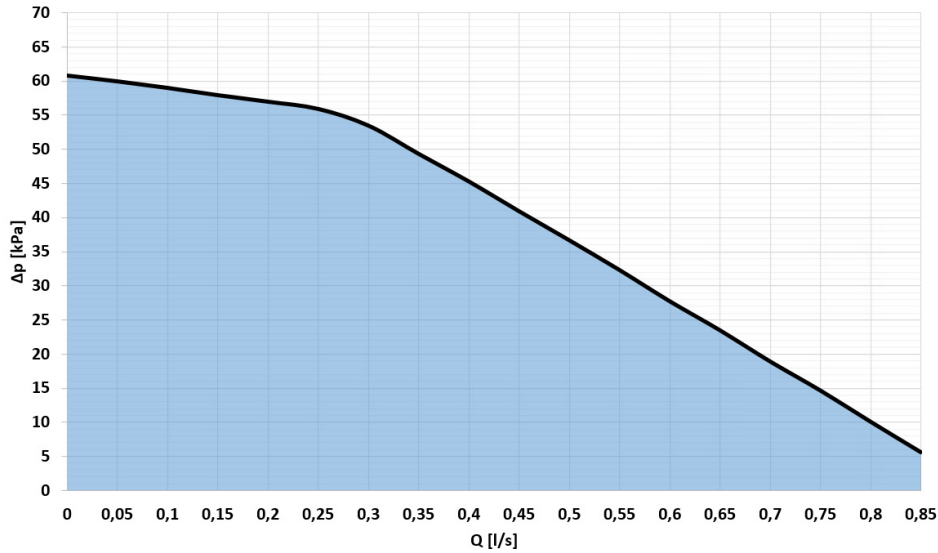

ΔP [kPa] = Available pressure  
Q [l/s] = Water flow-rate

Circulator operating field

# General technical data

## Available head for mixed booster system circulator

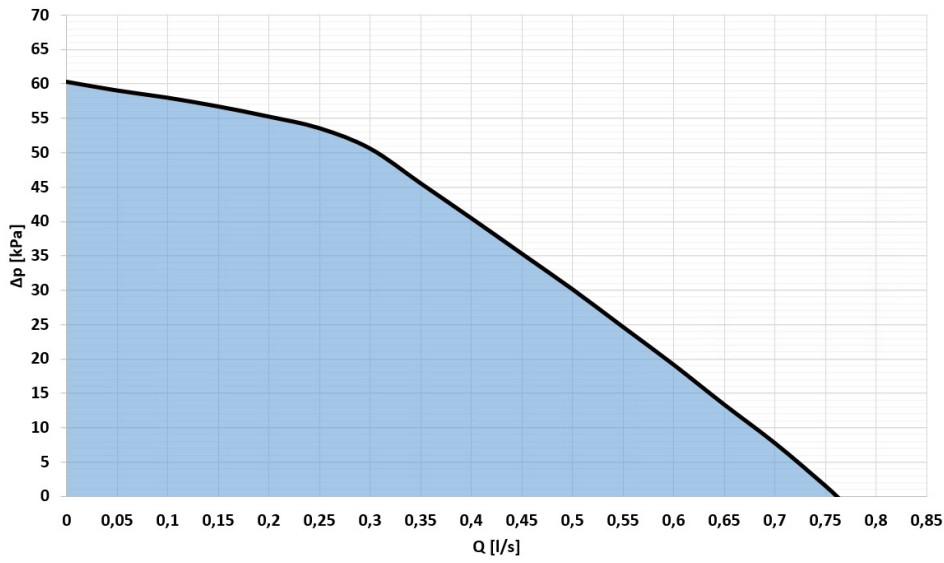

ΔP [kPa] = Available pressure  
Q [l/s] = Water flow-rate

Circulator operating field

## Pressure drops - VDACSX accessory

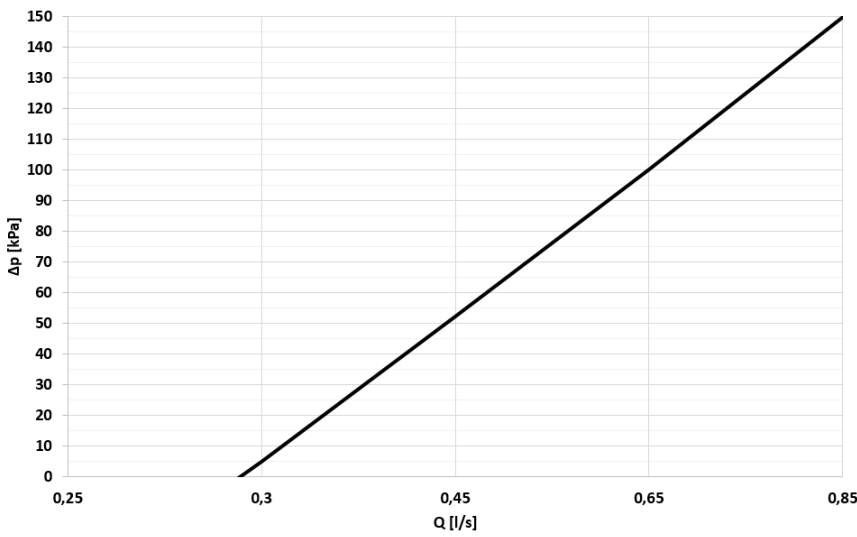

ΔP [kPa] = Available pressure  
Q [l/s] = Water flow-rate

## KCSX secondary circuit kit available pressure

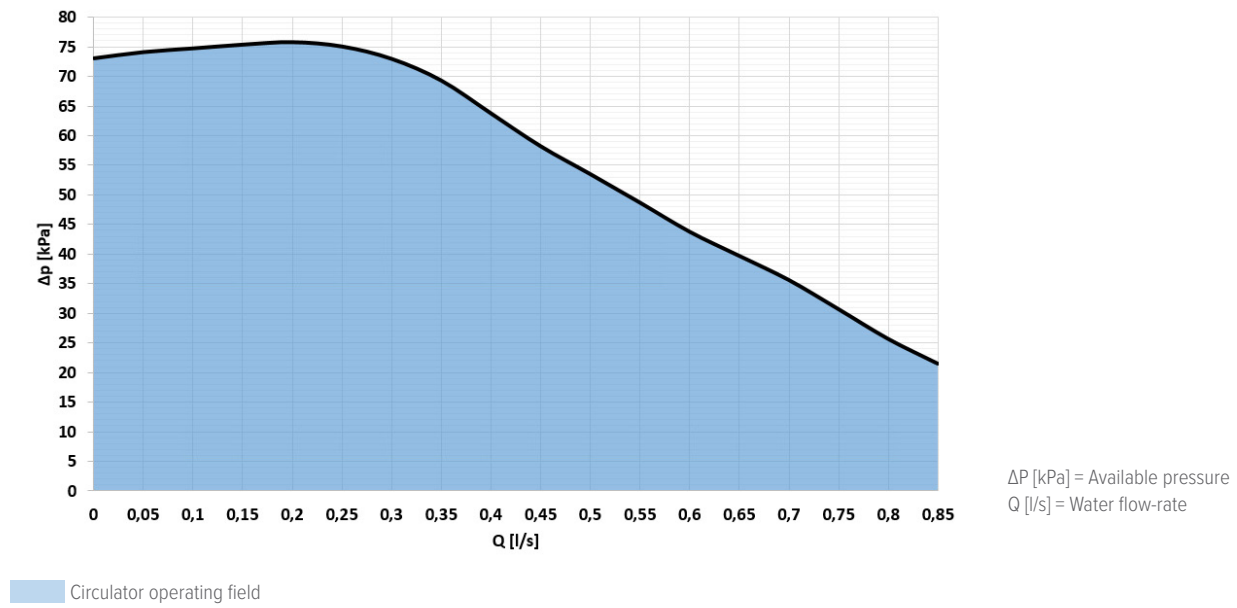

# General technical data

## Performance in heating

Sizes	Tae (°C) DB/WB	Water supply temperature (°C)															
		35			45			55			60			65			
		°C	kWt	kWe	COP	kWt	kWe	COP	kWt	kWe	COP	kWt	kWe	COP	kWt	kWe	COP
2.1	-25	3,68	2,92	1,26	3,38	2,54	1,33	\	\	\	\	\	\	\	\	\	\
	-20	4,38	2,81	1,56	4,02	2,56	1,57	3,80	2,61	1,46	\	\	\	\	\	\	\
	-15	5,04	2,53	1,99	4,76	2,57	1,85	4,50	2,62	1,72	3,40	2,47	1,38	\	\	\	\
	-10	5,65	2,40	2,36	5,41	2,55	2,12	5,06	2,63	1,93	3,94	2,49	1,58	\	\	\	\
	-7	6,25	2,30	2,72	6,06	2,54	2,39	5,62	2,64	2,13	4,22	2,47	1,71	\	\	\	\
	-5	6,25	2,15	2,91	6,05	2,41	2,51	5,64	2,53	2,23	4,38	2,42	1,81	\	\	\	\
	-2	6,25	1,93	3,25	6,02	2,21	2,72	5,66	2,37	2,38	4,62	2,34	1,98	\	\	\	\
	0	6,26	1,78	3,52	6,01	2,08	2,89	5,68	2,27	2,50	4,78	2,28	2,09	\	\	\	\
	2	6,26	1,63	3,84	6,00	1,95	3,07	5,70	2,16	2,63	4,93	2,23	2,21	\	\	\	\
	7	6,26	1,26	4,96	5,96	1,63	3,67	5,74	1,90	3,03	5,41	2,08	2,61	4,27	2,09	2,04	2,04
	15	5,75	1,25	4,59	6,20	1,47	4,21	5,63	1,65	3,41	5,04	1,76	2,87	4,87	1,90	2,56	2,56
	20	5,67	1,11	5,13	6,12	1,31	4,66	5,52	1,50	3,68	4,77	1,56	3,06	\	\	\	\
	35	5,97	0,82	7,27	5,99	0,99	6,05	5,61	1,22	4,62	\	\	\	\	\	\	\
3.1	-25	4,09	3,25	1,26	3,75	2,82	1,33	\	\	\	\	\	\	\	\	\	\
	-20	4,87	3,12	1,56	4,47	2,85	1,57	4,15	2,88	1,44	\	\	\	\	\	\	\
	-15	5,60	2,81	1,99	5,28	2,86	1,85	5,00	2,91	1,72	4,10	2,97	1,38	\	\	\	\
	-10	6,28	2,66	2,36	6,01	2,83	2,12	5,62	2,92	1,93	4,75	3,00	1,58	\	\	\	\
	-7	6,97	2,55	2,73	6,73	2,82	2,39	6,25	2,93	2,13	5,09	2,98	1,71	\	\	\	\
	-5	7,03	2,41	2,92	6,79	2,70	2,51	6,34	2,85	2,22	5,28	2,91	1,81	\	\	\	\
	-2	7,12	2,20	3,24	6,88	2,53	2,72	6,48	2,73	2,37	5,57	2,82	1,98	\	\	\	\
	0	7,19	2,06	3,50	6,93	2,41	2,88	6,57	2,65	2,48	5,76	2,75	2,09	\	\	\	\
	2	7,25	1,91	3,79	6,99	2,29	3,05	6,67	2,57	2,59	5,95	2,68	2,21	\	\	\	\
	7	7,41	1,56	4,76	7,13	2,00	3,58	6,90	2,37	2,91	6,42	2,52	2,55	5,25	2,60	2,02	2,02
	15	7,26	1,38	5,28	7,63	1,83	4,16	6,98	2,12	3,30	6,01	2,23	2,70	6,10	2,39	2,56	2,56
	20	6,98	1,18	5,91	7,42	1,68	4,42	6,81	1,89	3,60	5,98	1,95	3,06	\	\	\	\
	35	6,96	0,85	8,17	6,89	1,27	5,42	6,57	1,48	4,45	\	\	\	\	\	\	\
4.1	-25	5,33	2,68	1,99	5,21	2,65	1,97	\	\	\	\	\	\	\	\	\	\
	-20	6,15	2,83	2,17	5,68	2,97	1,91	4,50	2,90	1,55	\	\	\	\	\	\	\
	-15	6,90	2,98	2,32	5,93	2,97	2,00	4,94	2,92	1,69	3,99	2,84	1,41	\	\	\	\
	-10	7,64	2,99	2,56	6,45	2,97	2,17	6,07	3,05	1,99	5,19	2,86	1,81	\	\	\	\
	-7	8,35	3,00	2,78	6,97	2,98	2,34	6,22	3,07	2,03	5,32	2,88	1,85	\	\	\	\
	-5	8,46	2,83	2,99	7,26	2,89	2,51	6,45	2,94	2,19	6,04	3,00	2,02	\	\	\	\
	-2	8,62	2,57	3,35	7,69	2,75	2,79	6,78	2,97	2,28	6,45	3,08	2,09	\	\	\	\
	0	8,73	2,40	3,64	7,98	2,66	2,99	7,10	2,99	2,38	6,85	3,16	2,17	\	\	\	\
	2	8,84	2,23	3,97	8,26	2,57	3,21	7,33	2,87	2,56	6,98	3,03	2,31	\	\	\	\
	7	9,11	1,80	5,07	8,98	2,35	3,82	7,80	2,50	3,12	7,24	2,66	2,72	4,08	3,00	1,36	1,36
	15	9,09	1,51	6,04	8,91	2,03	4,38	8,32	2,34	3,55	7,68	2,49	3,09	5,71	2,39	2,39	2,39
	20	9,33	1,32	7,09	9,08	1,81	5,02	8,43	2,12	3,97	7,86	2,27	3,46	\	\	\	\
	35	8,50	1,06	8,05	9,29	1,46	6,34	8,16	1,80	4,72	\	\	\	\	\	\	\
5.1	-25	5,92	2,98	1,99	5,79	2,94	1,97	\	\	\	\	\	\	\	\	\	\
	-20	6,83	3,15	2,17	6,31	3,30	1,91	5,10	3,27	1,56	\	\	\	\	\	\	\
	-15	7,67	3,31	2,32	6,59	3,30	2,00	5,79	3,29	1,76	4,20	2,96	1,42	\	\	\	\
	-10	8,48	3,32	2,56	7,17	3,30	2,17	6,12	3,34	1,83	5,38	3,15	1,71	\	\	\	\
	-7	9,30	3,33	2,79	7,75	3,31	2,34	6,44	3,39	1,90	5,61	3,10	1,81	\	\	\	\
	-5	9,38	3,07	3,05	8,18	3,09	2,65	7,53	3,32	2,27	6,13	3,10	1,98	\	\	\	\
	-2	9,47	2,82	3,36	8,54	3,10	2,76	7,86	3,32	2,37	6,56	3,20	2,05	\	\	\	\
	0	9,56	2,55	3,76	8,89	3,10	2,87	8,18	3,31	2,47	6,99	3,30	2,12	\	\	\	\
	2	9,83	2,40	4,10	9,34	2,99	3,12	8,63	3,29	2,62	7,42	3,25	2,28	\	\	\	\
	7	10,30	2,09	4,93	10,30	2,73	3,77	9,72	3,20	3,04	8,23	2,96	2,78	4,85	3,11	1,56	1,56
	15	10,20	1,73	5,90	10,10	2,39	4,22	9,76	2,76	3,54	8,43	2,70	3,13	6,56	2,71	2,43	2,43
	20	10,70	1,59	6,72	10,30	2,12	4,86	9,85	2,54	3,88	8,90	2,56	3,48	\	\	\	\
	35	9,25	1,11	8,30	10,30	1,61	6,40	9,42	1,90	4,96	\	\	\	\	\	\	\

kWt: delivered heat capacity [kW].

kWe: electrical power absorbed [kW].

Tae: outdoor air temperature [°C].

Performance in relation to the difference between inlet and outlet water temperature = 5 °C

The values indicate the integrated heat capacity: the current heat capacity considering any defrosting cycles

Note: the data are at maximum operation

## Performance in heating

Sizes	Tae (°C) DB/WB	Water supply temperature (°C)															
		35			45			55			60			65			
		°C	kWt	kWe	COP	kWt	kWe	COP	kWt	kWe	COP	kWt	kWe	COP	kWt	kWe	COP
6.1	-25	9,40	5,66	1,66	8,74	5,53	1,58	\	\	\	\	\	\	\	\	\	\
	-20	10,43	5,64	1,85	9,40	5,63	1,67	7,62	5,69	1,34	\	\	\	\	\	\	\
	-15	11,63	5,73	2,03	9,97	5,60	1,78	8,34	5,63	1,48	5,87	4,69	1,25	\	\	\	\
	-10	12,74	5,69	2,24	10,93	5,62	1,95	9,10	5,69	1,60	6,70	5,13	1,30	\	\	\	\
	-7	13,85	5,65	2,45	11,88	5,63	2,11	9,86	5,73	1,72	8,05	5,06	1,59	\	\	\	\
	-5	13,96	5,29	2,64	12,25	5,40	2,27	10,44	5,58	1,87	8,21	5,14	1,60	\	\	\	\
	-2	14,12	4,75	2,98	12,81	5,05	2,54	11,30	5,35	2,11	8,37	5,09	1,65	\	\	\	\
	0	14,23	4,38	3,25	13,19	4,81	2,74	11,88	5,20	2,29	8,52	5,03	1,69	\	\	\	\
	2	14,33	4,02	3,57	13,56	4,58	2,96	12,46	5,04	2,47	10,06	5,05	1,99	\	\	\	\
	7	14,60	3,11	4,69	14,50	4,00	3,63	13,90	4,66	2,97	13,00	5,07	2,56	11,50	5,17	2,23	\
	15	14,40	2,65	5,43	14,60	3,53	4,14	12,10	3,97	3,03	12,30	4,32	2,85	11,70	4,42	2,65	\
	20	14,20	2,20	6,47	14,80	3,15	4,69	12,00	3,55	3,39	10,80	3,71	2,90	\	\	\	\
	35	14,70	1,80	8,16	14,60	2,50	5,83	12,90	2,79	4,62	\	\	\	\	\	\	\
7.1	-25	9,45	5,69	1,66	8,86	5,68	1,56	\	\	\	\	\	\	\	\	\	\
	-20	10,49	5,78	1,81	9,54	5,77	1,65	7,80	5,84	1,34	\	\	\	\	\	\	\
	-15	11,70	5,76	2,03	10,14	5,73	1,77	8,47	5,79	1,46	6,15	5,14	1,20	\	\	\	\
	-10	12,89	5,78	2,23	11,11	5,74	1,93	9,19	5,77	1,59	6,87	5,36	1,28	\	\	\	\
	-7	14,09	5,79	2,43	12,09	5,76	2,10	9,91	5,76	1,72	8,15	5,62	1,45	\	\	\	\
	-5	14,29	5,44	2,63	12,60	5,56	2,27	10,56	5,64	1,87	8,49	5,58	1,52	\	\	\	\
	-2	14,59	4,92	2,96	13,38	5,25	2,55	11,55	5,46	2,11	9,00	5,52	1,63	\	\	\	\
	0	14,80	4,58	3,23	13,89	5,05	2,75	12,20	5,34	2,29	9,34	5,48	1,70	\	\	\	\
	2	15,00	4,23	3,54	14,41	4,85	2,97	12,86	5,22	2,46	10,52	5,43	1,94	\	\	\	\
	7	15,50	3,37	4,59	15,70	4,35	3,60	14,50	4,92	2,95	13,20	5,20	2,54	10,40	4,95	2,10	\
	15	15,20	2,94	5,16	15,50	3,98	3,89	13,00	4,02	3,24	12,70	4,48	2,84	11,90	4,97	2,41	\
	20	14,60	2,59	5,65	15,10	3,42	4,42	12,70	3,62	3,52	11,00	3,77	2,92	\	\	\	\
	35	15,00	1,87	8,02	15,30	2,65	5,77	13,00	2,77	4,69	\	\	\	\	\	\	\
8.1	-25	9,50	5,72	1,66	8,98	5,83	1,54	\	\	\	\	\	\	\	\	\	\
	-20	10,55	5,93	1,78	9,68	5,90	1,64	7,98	5,99	1,33	\	\	\	\	\	\	\
	-15	11,76	5,79	2,03	10,30	5,85	1,76	8,61	5,94	1,45	6,42	5,59	1,15	\	\	\	\
	-10	13,05	5,86	2,23	11,30	5,87	1,93	9,29	5,86	1,59	7,04	5,59	1,26	\	\	\	\
	-7	14,33	5,92	2,42	12,30	5,89	2,09	9,96	5,79	1,72	8,25	6,18	1,33	\	\	\	\
	-5	14,68	5,62	2,61	13,40	5,88	2,28	12,60	5,92	2,13	8,62	5,97	1,45	\	\	\	\
	-2	15,21	5,16	2,95	13,75	5,61	2,45	12,70	5,67	2,24	9,09	5,76	1,58	\	\	\	\
	0	15,57	4,86	3,21	14,10	5,33	2,64	12,80	5,42	2,37	9,56	5,54	1,72	\	\	\	\
	2	15,92	4,55	3,50	15,00	5,15	2,92	13,65	5,32	2,57	11,13	5,45	2,04	\	\	\	\
	7	16,80	3,79	4,43	16,60	4,71	3,53	16,20	5,53	2,89	14,10	5,34	2,63	11,30	5,13	2,20	\
	15	18,90	3,48	5,43	18,50	4,53	4,09	17,50	5,11	3,42	14,70	4,83	3,06	12,50	4,80	2,60	\
	20	16,70	2,69	6,21	16,10	3,77	4,28	15,00	4,32	3,46	13,10	4,39	3,00	\	\	\	\
	35	16,30	1,94	8,42	15,90	2,79	5,68	13,40	3,07	4,35	\	\	\	\	\	\	\

kWt: delivered heat capacity [kW].

kWe: electrical power absorbed [kW].

Tae: outdoor air temperature [°C].

Performance in relation to the difference between inlet and outlet water temperature = 5 °C

The values indicate the integrated heat capacity: the current heat capacity considering any defrosting cycles

Note: the data are at maximum operation

# General technical data

## Performance in cooling

Sizes	Tae	Water supply temperature (°C)																	
		5			7			10			12			15			18		
		°C	kWf	kWe	EER	kWf	kWe	EER	kWf	kWe	EER	kWf	kWe	EER	kWf	kWe	EER	kWf	kWe
2.1	20	4,72	1,04	4,54	5,24	1,16	4,50	6,01	1,35	4,47	6,37	1,32	4,82	6,90	1,28	5,39	7,44	1,24	6,00
	25	5,87	1,30	4,51	6,31	1,52	4,16	6,97	1,84	3,80	7,12	1,70	4,19	7,34	1,48	4,95	7,56	1,27	5,96
	30	5,84	1,55	3,78	6,22	1,67	3,73	6,80	1,85	3,67	6,90	1,73	3,98	7,06	1,56	4,53	7,22	1,38	5,22
	35	5,80	1,79	3,24	6,14	1,82	3,37	6,64	1,87	3,55	6,70	1,77	3,78	6,79	1,63	4,16	6,88	1,49	4,63
	40	3,80	1,51	2,52	4,31	1,63	2,65	5,08	1,81	2,81	5,24	1,74	3,01	5,47	1,64	3,35	5,71	1,53	3,73
	43	2,58	1,15	2,24	3,07	1,30	2,36	3,80	1,52	2,51	4,10	1,49	2,75	4,55	1,45	3,14	5,00	1,41	3,55
3.1	20	5,41	1,38	3,93	5,90	1,40	4,21	6,63	1,43	4,62	7,24	1,45	4,98	8,16	1,49	5,47	8,26	1,38	6,00
	25	7,16	1,80	3,98	7,24	1,79	4,05	7,37	1,77	4,17	7,71	1,67	4,61	8,23	1,53	5,39	8,40	1,41	5,96
	30	6,50	1,85	3,51	6,82	1,87	3,64	7,29	1,90	3,84	7,48	1,80	4,16	7,77	1,65	4,72	8,02	1,54	5,22
	35	5,84	1,90	3,07	6,39	1,95	3,27	7,22	2,03	3,55	7,26	1,92	3,78	7,31	1,76	4,15	7,65	1,65	4,63
	40	3,80	1,51	2,52	4,31	1,63	2,65	5,08	1,81	2,81	5,41	1,78	3,04	5,91	1,73	3,41	6,34	1,70	3,73
	43	2,58	1,15	2,24	3,07	1,30	2,36	3,80	1,52	2,51	4,31	1,54	2,81	5,08	1,56	3,26	5,56	1,57	3,55
4.1	20	5,68	1,15	4,96	6,23	1,21	5,17	7,06	1,29	5,46	7,59	1,31	5,77	8,38	1,35	6,22	9,54	1,50	6,36
	25	6,47	1,48	4,36	7,01	1,54	4,55	7,82	1,63	4,81	8,40	1,65	5,09	9,26	1,68	5,52	10,45	1,81	5,77
	30	7,27	1,89	3,85	7,79	1,94	4,02	8,57	2,01	4,25	9,20	2,03	4,53	10,15	2,06	4,93	11,38	2,14	5,31
	35	7,39	2,25	3,28	7,94	2,27	3,49	8,77	2,31	3,80	9,35	2,31	4,05	10,21	2,31	4,43	11,13	2,36	4,71
	40	6,61	2,52	2,62	6,93	2,46	2,82	7,42	2,37	3,14	8,00	2,43	3,29	8,88	2,53	3,51	9,69	2,52	3,85
	43	5,09	2,28	2,23	5,31	2,24	2,37	5,64	2,19	2,58	6,08	2,17	2,81	6,73	2,13	3,16	7,58	2,15	3,52
5.1	20	6,20	1,28	4,86	6,93	1,35	5,13	7,19	1,39	5,17	7,78	1,41	5,50	8,67	1,45	5,97	9,94	1,56	6,36
	25	7,13	1,68	4,24	7,96	1,77	4,51	8,26	1,81	4,56	8,90	1,84	4,84	9,87	1,88	5,24	11,15	1,99	5,59
	30	8,06	2,17	3,71	9,00	2,27	3,96	9,34	2,31	4,05	10,04	2,35	4,28	11,08	2,40	4,62	12,36	2,50	4,94
	35	8,13	2,48	3,12	9,10	2,51	3,63	9,48	2,43	3,72	10,10	2,51	4,03	11,03	2,62	4,21	12,03	2,66	4,53
	40	6,61	2,52	2,62	7,28	2,51	2,90	7,42	2,37	3,14	8,00	2,43	3,29	8,88	2,53	3,51	9,69	2,52	3,85
	43	5,09	2,28	2,23	5,58	2,29	2,44	5,64	2,19	2,58	6,08	2,17	2,81	6,73	2,13	3,16	7,58	2,15	3,52
6.1	20	7,78	2,03	3,83	10,07	2,47	4,07	12,15	2,96	4,10	12,95	3,02	4,28	14,16	3,12	4,54	15,22	3,13	4,86
	25	10,10	3,00	3,37	12,24	3,34	3,66	13,80	3,61	3,82	14,61	3,73	3,92	15,82	3,91	4,04	16,53	3,97	4,16
	30	9,99	3,58	2,79	12,01	3,91	3,07	13,43	4,13	3,25	14,13	4,15	3,41	15,18	4,17	3,64	15,77	4,16	3,79
	35	9,89	4,52	2,19	11,80	4,81	2,45	13,07	4,90	2,67	13,65	4,76	2,87	14,53	4,56	3,19	15,02	4,45	3,37
	40	8,11	4,53	1,79	9,32	4,58	2,03	9,87	4,33	2,28	10,19	4,17	2,45	10,67	3,92	2,72	11,58	4,00	2,90
	43	5,20	3,72	1,40	5,88	3,64	1,61	6,11	3,26	1,87	6,60	3,16	2,09	7,33	3,02	2,43	8,05	3,12	2,58
7.1	20	8,17	2,17	3,77	11,02	2,75	4,02	12,80	3,16	4,04	13,64	3,23	4,23	14,90	3,33	4,47	15,50	3,22	4,82
	25	10,60	3,19	3,32	13,38	3,69	3,62	14,50	3,84	3,77	15,34	3,97	3,87	16,60	4,16	3,99	16,84	4,07	4,14
	30	10,50	3,96	2,65	13,13	4,48	2,93	14,10	4,53	3,11	14,82	4,54	3,26	15,90	4,56	3,49	16,08	4,33	3,71
	35	10,40	4,81	2,16	12,86	5,36	2,40	13,70	5,32	2,58	14,34	5,14	2,79	15,30	4,88	3,13	15,30	4,62	3,31
	40	8,11	4,53	1,79	9,70	4,76	2,04	9,87	4,33	2,28	10,20	4,17	2,45	10,70	3,92	2,72	11,60	4,00	2,90
	43	5,20	3,72	1,40	6,12	3,78	1,62	6,11	3,26	1,87	6,60	3,16	2,09	7,33	3,02	2,43	8,05	3,12	2,58
8.1	20	8,99	2,43	3,70	12,09	3,08	3,93	14,00	3,55	3,96	14,72	3,55	4,14	15,80	3,56	4,42	16,46	3,44	4,78
	25	11,70	3,59	3,25	14,72	4,15	3,54	15,90	4,32	3,69	16,50	4,38	3,77	17,40	4,47	3,90	17,70	4,37	4,05
	30	11,50	4,46	2,59	14,41	5,05	2,85	15,50	5,11	3,04	16,18	5,09	3,18	17,20	5,05	3,41	17,14	4,82	3,56
	35	11,40	5,42	2,11	14,20	6,05	2,35	15,10	6,00	2,52	15,66	5,84	2,68	16,50	5,60	2,94	16,38	5,22	3,14
	40	8,92	5,11	1,75	10,68	5,37	1,99	10,90	4,89	2,22	11,22	4,70	2,39	11,70	4,42	2,65	12,72	4,58	2,78
	43	5,98	4,50	1,33	7,17	4,65	1,54	7,33	4,12	1,78	8,00	4,04	1,98	9,01	3,91	2,31	9,90	4,04	2,45

kWf: delivered cooling capacity [kW].

kWe: electrical power absorbed [kW].

Tae: outdoor air temperature [°C].

Performance in relation to the difference between inlet and outlet water temperature = 5 °C

Note: the data are at maximum operation

## Sizing the refrigerant pipes

Equivalent length of pipes (metres) = Effective length (metres) +  
Number of bends x K

Consider K= 0.3 m per wide radius elbow bend.

Consider K= 0.5 m per standard 90° elbow bend.

⚠ To correctly install the refrigerant pipes and charge the refrigerant gas, refer to the SPHERA EVO 2.0 MANUAL

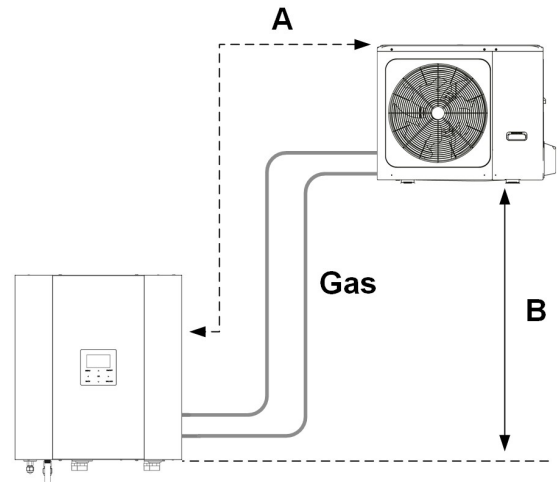

SIZE		2.1	3.1	4.1	5.1	6.1	7.1	8.1
<b>Length and height difference of refrigerant pipes</b>								
A - Refrigerant pipe min/max equivalent length	m	2 - 30	2 - 30	2 - 30	2 - 30	2 - 30	2 - 30	2 - 30
B - Maximum refrigerant pipe height difference with outdoor unit higher than indoors unit	m	25	25	25	25	25	25	25
B - Maximum refrigerant pipe height difference with outdoor unit underthan indoor unit.	m	25	25	25	25	25	25	25
<b>Diameters of refrigerant pipes</b>								
Gas pipe diameter	inch	5/8"	5/8"	5/8"	5/8"	5/8"	5/8"	5/8"
Fluid line diameter	inch	1/4"	1/4"	3/8"	3/8"	3/8"	3/8"	3/8"
Additional charge per metre	kg/m	0,020	0,020	0,038	0,038	0,038	0,038	0,038

## Determination of cooling and heating power loss

The equivalent length of the cooling lines results in a loss of cooling and heating power supplied to the circuit and DHW system. The graph shows the amount of this loss of powergh.

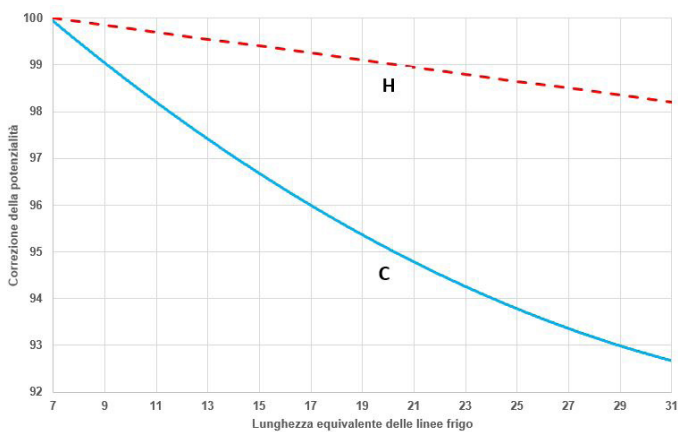

C = Cooling power efficiency curve

H = Heating power efficiency curve

# Electrical connections

The electrical hookup must be conforming with the local regulations. The hookup must be done by a specialised technician, qualified to work on live equipment.

SPHERA EVO 2.0 can be controlled with the on-board controller. To operate the unit, you may use: the CONTROL4 NRG supervision system or normal electromechanical thermostats.

For more information on connections, consult the installation manual.

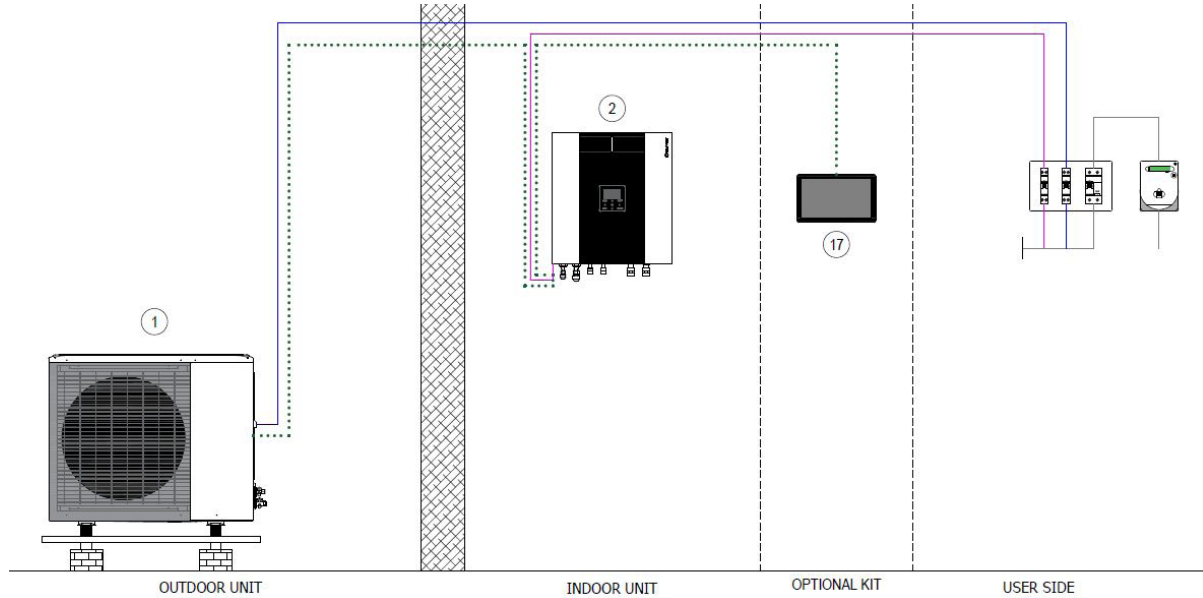

1. Outdoor unit
2. Indoor unit
3. CONTROL 4 NRG

- A. Liquid line
- B. Gas line
- C. ACS outlet
- D. DHW recirculation inlet
- E. Aqueduct inlet
- F. Solar outlet
- G. Solar inlet
- H. Power line input
- I. Plant return
- J. System supply
- K. Condensate drain

————— 220-240V~50Hz  
 ..... BUS RS 485

# Auxiliary and hybrid version heat sources

The electrical connection must be carried out in accordance with national regulations in force. The connection must be carried out by specialised personnel who are qualified to work with live voltage.

SPHERA EVO 2.0 can be controlled with the built-in control panel. The unit can be called using: the CONTROL4 NRG supervisory system or common electromechanical thermostats.

Refer to the installation manual for more information on the connections.

⚠ Only one of IBH or AHS can be managed

The additional electric heater or boiler can operate as:

- Integration: when it is not convenient/possible to work with the heat pump capacity alone
- Replacement: outside the work settings of the heat pump
- Back-up: in case of unit failure (the unit keeps the pump running at maximum speed)

A third-party supplier's boiler, if any, must be installed in parallel with the heat pump and can act:

- on the system and DHW: installed directly on the system, in this case its operation will require a dedicated T1 temperature probe (to be selected separately) to be installed downstream.

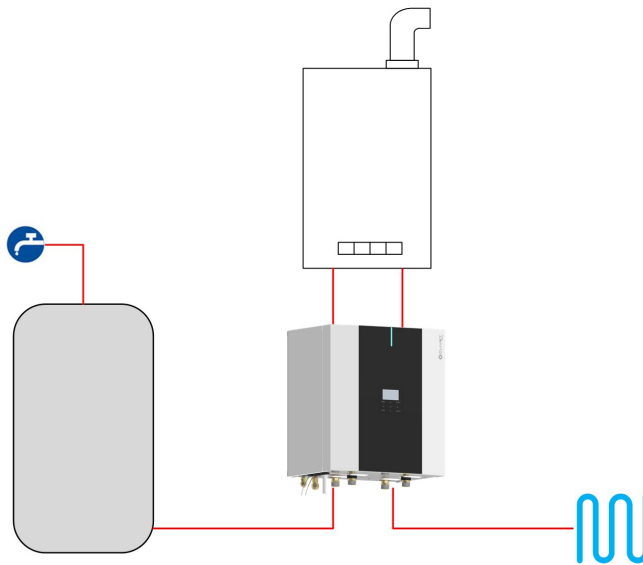

⚠ Requires installation of the KCCEX kit, the T1 probe is included and must be fitted inside the indoor unit downstream of the boiler

- only on the system: installed on a hydraulic separator, where the T1 probe (to be selected separately) must also be fitted

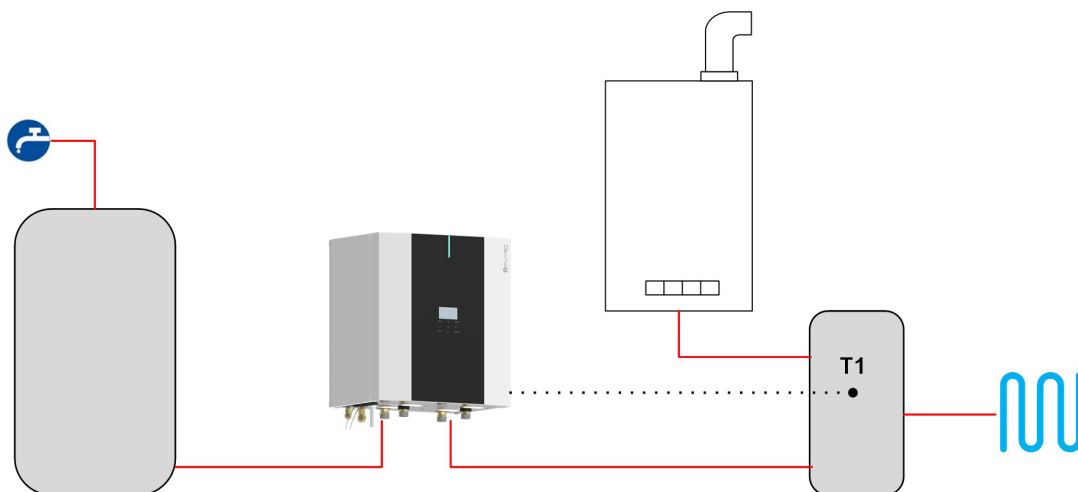

# Auxiliary and hybrid version heat sources

The activation operating mode (in Heating, DHW production or both) must be selected with the dip-switches on the board during installation.

Activation of the auxiliary source is linked to the simultaneous presence of 3 conditions, each of which is associated with a parameter that can be adjusted during initial start-up on the user interface:

- very low outdoor temperature  
parameter  $T4\_IBH\_ON$  or  $T4\_AHS\_ON$ : the minimum outdoor air temperature for heat pump operation only

⚠ To make the auxiliary source work only as a replacement for the unit, set the parameter to the same value as  $T4HMIN$  (default  $-15^{\circ}C$ , adjustable  $-25\div15$ ): the minimum outdoor air

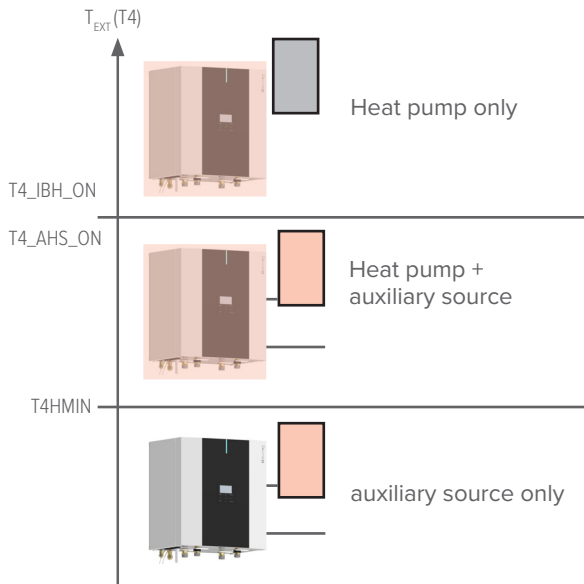

temperature at which the heat pump can operate.

- supply temperature too far from the set-point  
parameter  $dt1\_IBH\_ON$  or  $dt1\_AHS\_ON$ : the minimum  $\Delta T$  between the water set-point  $TS1$  and unit supply set-point  $T1$
- too long to reach the set-point  
parameter  $t\_IBH\_DELAY$  or  $t\_AHS\_DELAY$ : the maximum waiting time between compressor start-up and auxiliary source activation

⚠ The BACKUP HEATER function on the HMI allows activation of the IBH or AHS auxiliary source to be forced

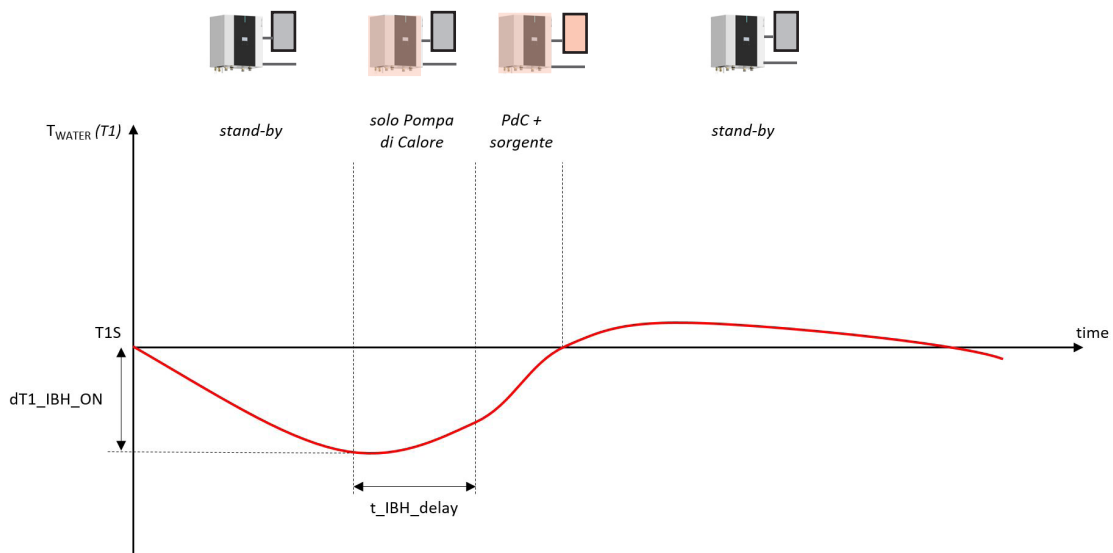

The unit can manage the AHS set-point dynamically with a 0-10V signal, with parameters:

- $MAX\_SETHEATER$  and  $MIN\_SETHEATER$ : the minimum and maximum set-points that can be set in the boiler
- $MAX\_SIGHEATER$  and  $MIN\_SIGHEATER$ : the 0-10V signals linked to the minimum and maximum set-points that can be set in the boiler

## General description of the system and possible connections

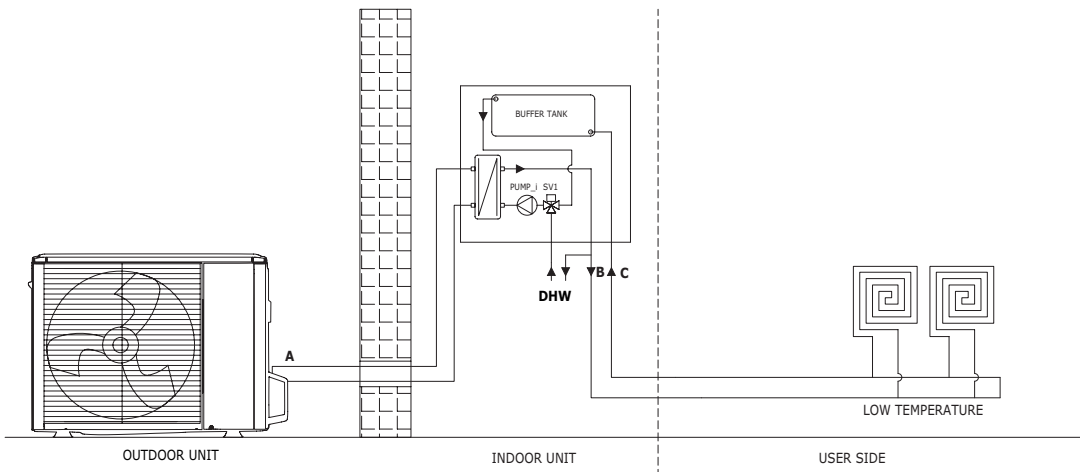

### Standard

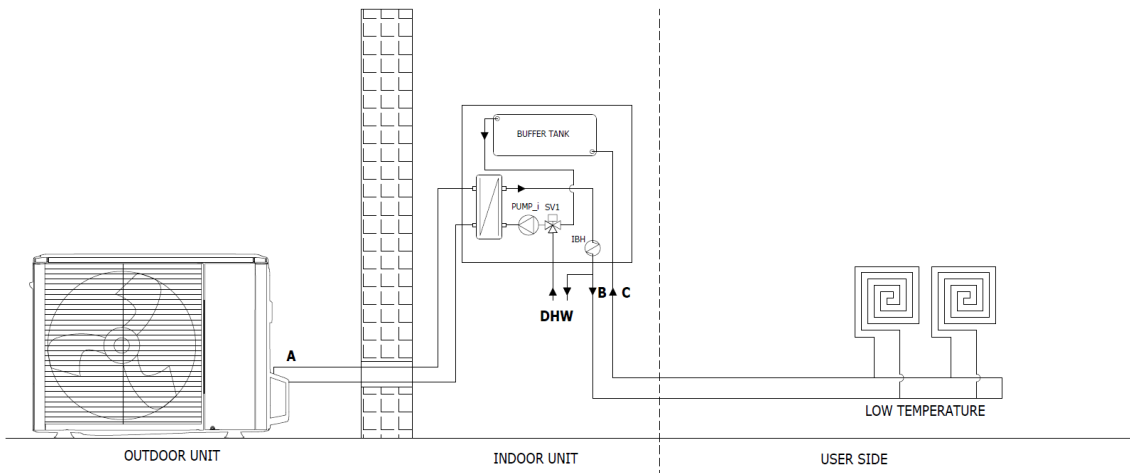

### Electric heater

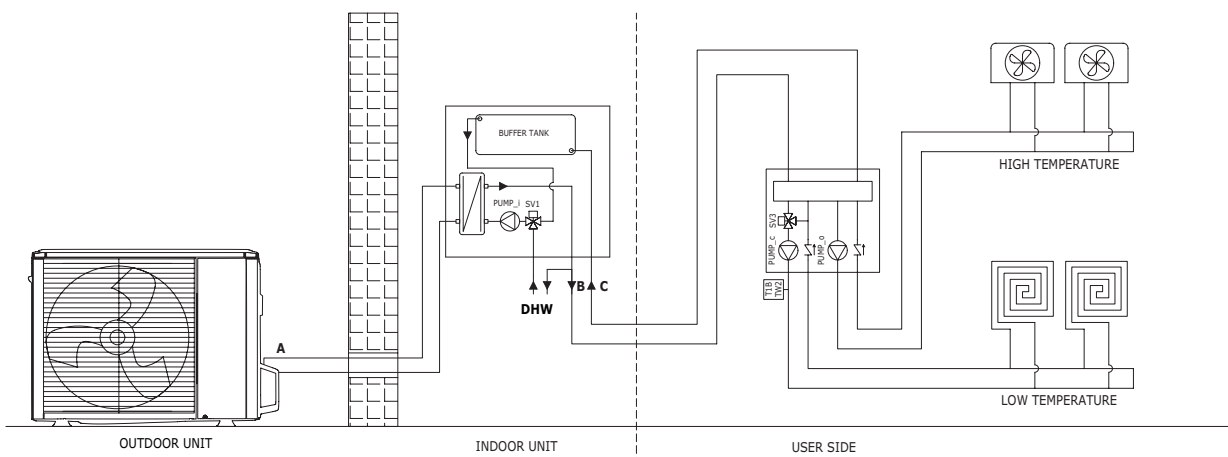

### 2 zone kit

# System connections

## General description of the system and possible connections

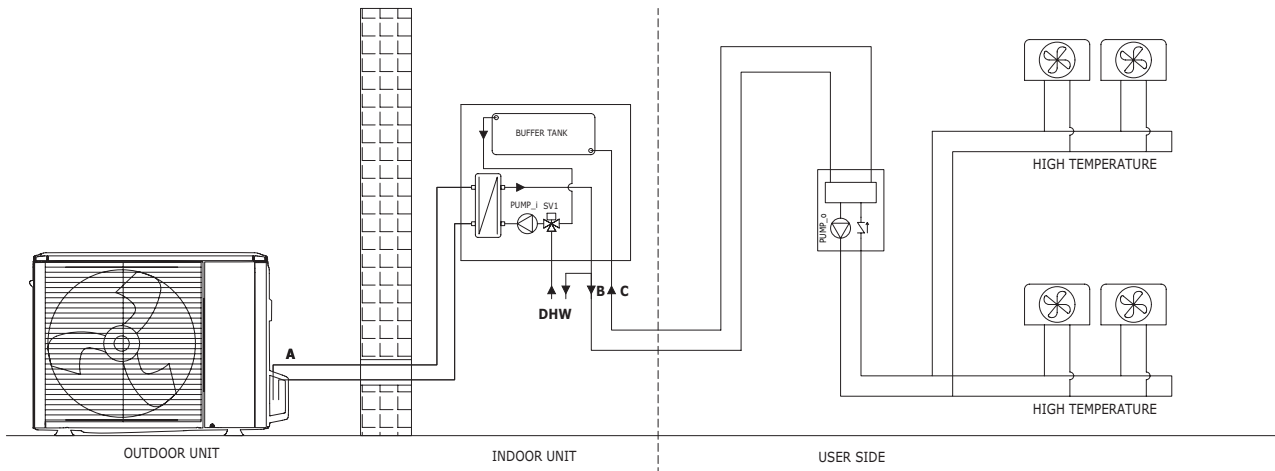

### Single Zone kit

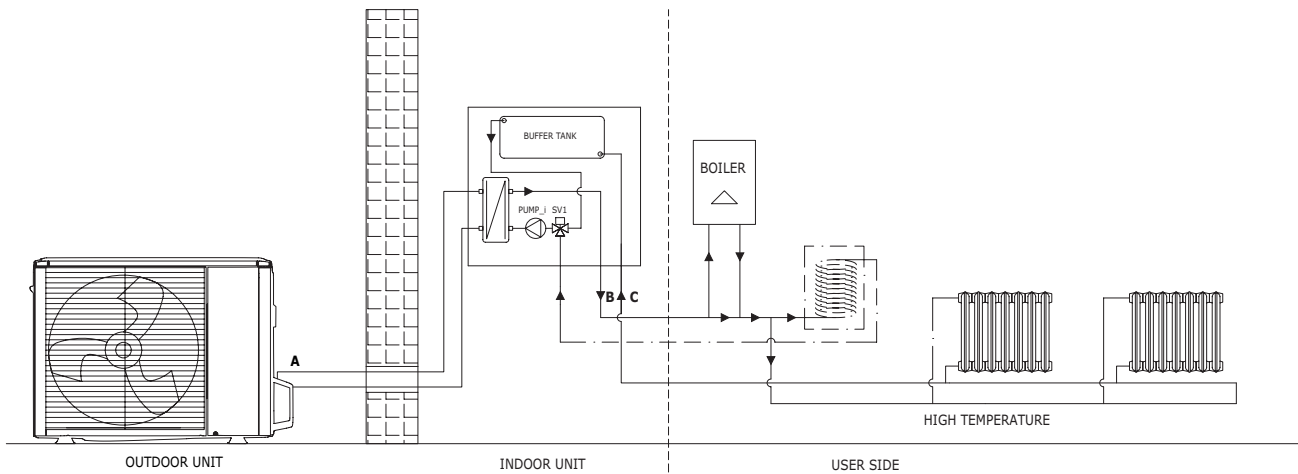

### Boiler

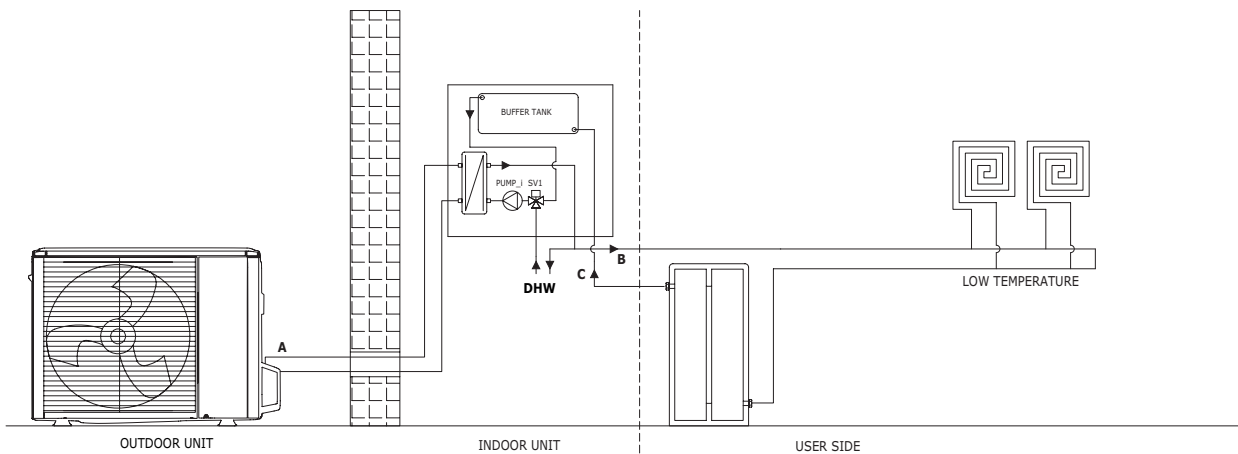

### Inertial storage 40 L

## General description of the system and possible connections

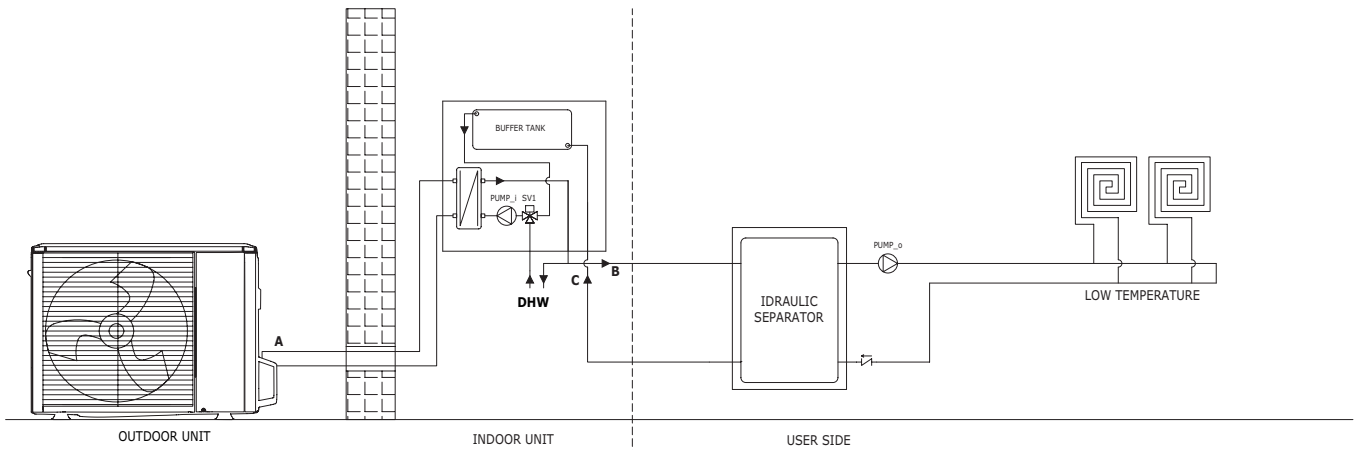

### Circuit breaker 50L

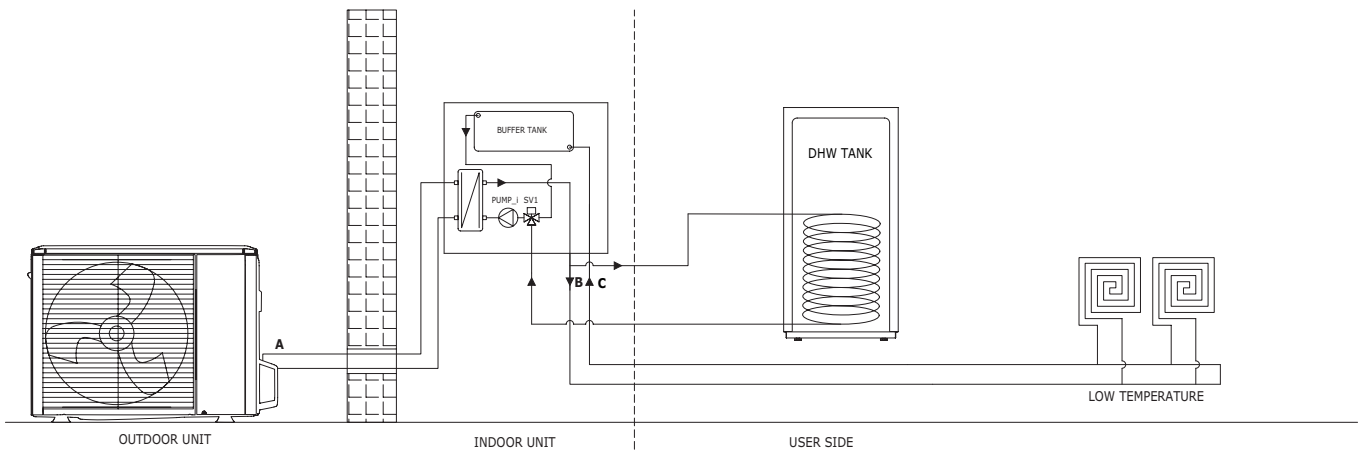

### DHW storage

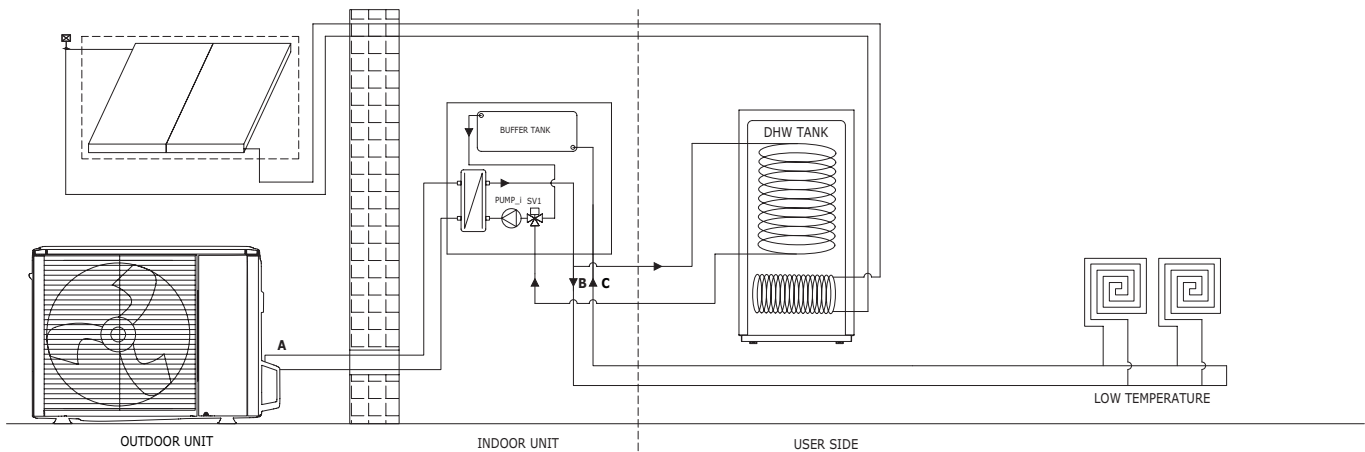

# Data for the UNI/TS 11300 calculation

Clivet S.p.A. declares that the data to be used for the calculation pursuant to UNI/TS 11300 part 4 of the efficiency of their heat pump are given in the following tables.

The data given in this document may be updated without advance notice by the manufacturer when upgrading his product range.

## UNI/TS 11300 Part 4

### SPHERA EVO 2.0 - Size 2.1

Data for determination of COPPL T delivery 20°C		Tdesignh	A	B	C	D
2.1	Te	-10	-7	2	7	12
	PLR	100%	88%	54%	35%	15%
	DC		4,74	4,50	4,32	4,33
	CR		1,00	0,65	0,44	0,19
	P	5,39	4,74	3,05	1,99	1,45
	COP (part load)		3,15	4,96	6,81	6,23
	COP (full load)		3,15	4,46	5,42	6,37
	Fcop		1,00	1,11	1,26	0,98
Data to be provided for power and COP under full load cold source air						
2.1	Te	Tm	-7	2	7	12
	Heating capacity $\Phi_{H,HP out}$ (kW)	35 °C	4,74	4,50	4,32	4,33
		45 °C	4,31	4,35	4,16	4,16
		55 °C	4,40	4,40	4,08	4,50
	COP	35 °C	3,15	4,46	5,42	6,37
		45 °C	2,51	3,27	3,93	4,52
	55 °C	1,99	2,56	3,00	3,44	
DHW Power and COP data under full load			Te			
2.1	Te	Tm	7	15	20	35
	Heating capacity $\Phi_{H,HP out}$ (kW)	55 °C	4,08	5,11	5,71	6,85
	COP	55 °C	3,00	3,84	4,23	3,90

### SPHERA EVO 2.0 - Size 3.1

Data for determination of COPPL T delivery 20°C		Tdesignh	A	B	C	D
3.1	Te	-10	-7	2	7	12
	PLR	100%	88%	54%	35%	15%
	DC		5,51	5,89	6,18	6,28
	CR		1,00	0,57	0,35	0,15
	P	6,26	5,51	3,30	2,24	1,45
	COP (part load)		3,13	4,91	7,11	5,70
	COP (full load)		3,13	4,15	5,21	6,10
	Fcop		1,00	1,18	1,36	0,93
Data to be provided for power and COP under full load cold source air						
3.1	Te	Tm	-7	2	7	12
	Heating capacity $\Phi_{H,HP out}$ (kW)	35 °C	5,51	5,89	6,18	6,28
		45 °C	5,22	6,42	6,03	6,53
		55 °C	5,15	5,46	5,94	6,64
	COP	35 °C	3,13	4,15	5,21	6,10
		45 °C	2,41	3,07	3,83	4,41
	55 °C	2,03	2,56	3,07	3,55	
DHW Power and COP data under full load			Te			
3.1	Te	Tm	7	15	20	35
	Heating capacity $\Phi_{H,HP out}$ (kW)	55 °C	5,94	6,99	7,33	8,80
	COP	55 °C	3,07	3,97	4,44	4,10

# Data for the UNI/TS 11300 calculation

## SPHERA EVO 2.0 - Size 4.1

Data for determination of COPPL T delivery 20°C		Tdesignh	A	B	C	D
4.1	Te	-10	-7	2	7	12
	PLR	100%	88%	54%	35%	15%
	DC		7,15	5,64	8,30	8,21
	CR		1,00	0,78	0,34	0,15
	P	8,13	7,15	4,65	2,91	1,85
	COP (part load)		3,30	5,17	7,08	6,01
	COP (full load)		3,30	3,69	5,31	6,41
	Fcop		1,00	1,40	1,33	0,94
Data to be provided for power and COP under full load cold source air		Te				
4.1	Te	Tm	-7	2	7	12
	Heating capacity $\Phi_{H,HP out}$ (kW)	35 °C	7,15	5,64	8,30	8,21
		45 °C	6,34	6,59	8,22	8,07
		55 °C	6,08	6,27	7,50	7,55
	COP	35 °C	3,30	3,69	5,31	6,41
		45 °C	2,56	3,26	3,95	4,69
	55 °C	2,17	2,69	3,19	3,72	
DHW Power and COP data under full load		Te				
4.1	Te	Tm	7	15	20	35
	Heating capacity $\Phi_{H,HP out}$ (kW)	55 °C	7,50	8,37	9,18	11,02
	COP	55 °C	3,19	4,11	4,50	4,15

## SPHERA EVO 2.0 - Size 5.1

Data for determination of COPPL T delivery 20°C		Tdesignh	A	B	C	D
5.1	Te	-10	-7	2	7	12
	PLR	100%	88%	54%	35%	15%
	DC		8,45	9,30	10,09	10,26
	CR		1,00	0,56	0,33	0,14
	P	9,60	8,45	5,23	3,47	1,96
	COP (part load)		3,18	5,03	7,33	6,16
	COP (full load)		3,18	4,12	5,01	5,97
	Fcop		1,00	1,22	1,46	1,03
Data to be provided for power and COP under full load cold source air		Te				
5.1	Te	Tm	-7	2	7	12
	Heating capacity $\Phi_{H,HP out}$ (kW)	35 °C	8,45	9,30	10,09	10,26
		45 °C	7,71	9,16	10,01	10,06
		55 °C	7,08	8,49	9,60	9,19
	COP	35 °C	3,18	4,12	5,01	5,97
		45 °C	2,59	3,11	3,86	4,32
	55 °C	2,11	2,66	3,10	3,65	
DHW Power and COP data under full load		Te				
5.1	Te	Tm	7	15	20	35
	Heating capacity $\Phi_{H,HP out}$ (kW)	55 °C	9,60	8,99	8,78	10,54
	COP	55 °C	3,10	4,03	4,53	4,18

Terms and definitions

Tm = Delivery temperature

Tdesignh = A - Average design climate temperature (pursuant to UNI EN 14825)

A, B, C, D = names of the four conditions with which different outdoors air temperatures are associated (Te)

Te = Outdoors air temperature

PLR = part load ratio

DC = power under full load referred to the specified temperatures

CR = heat pump load factor

P = system power demand

COP' (full load) = COP under full load referred to the indicated outdoors air temperatures

COP' (partial load) = COP under partial load referred to the indicated outdoors air temperatures

fCOP = COP correction factor, as follows: COP' (full load) / COP (partial load)

HP = heat pump

DHW = domestic hot water

# Data for the UNI/TS 11300 calculation

## SPHERA EVO 2.0 - Size 6.1

Data for determination of COPPL T delivery 20°C		Tdesignh	A	B	C	D
6.1	Te	-10	-7	2	7	12
	PLR	100%	88%	54%	35%	15%
	DC		10,69	13,01	12,13	12,26
	CR		1,00	0,50	0,35	0,15
	P	12,14	10,69	6,57	4,48	3,67
	COP (part load)		3,07	4,68	6,90	6,33
	COP (full load)		3,07	3,93	5,00	5,68
	Fcop		1,00	1,19	1,38	1,12
Data to be provided for power and COP under full load cold source air		Te				
6.1	Te	Tm	-7	2	7	12
	Heating capacity $\Phi_{H,HP out}$ (kW)	35 °C	10,69	13,01	12,13	12,26
		45 °C	11,21	12,52	12,30	11,56
		55 °C	10,10	12,05	12,07	10,89
	COP	35 °C	3,07	3,93	5,00	5,68
		45 °C	3,14	3,34	3,80	4,59
55 °C		1,76	2,88	3,10	3,78	
DHW Power and COP data under full load		Te				
6.1	Te	Tm	7	15	20	35
	Heating capacity $\Phi_{H,HP out}$ (kW)	55 °C	12,07	12,30	13,71	16,45
	COP	55 °C	3,10	4,19	4,59	4,23

## SPHERA EVO 2.0 - Size 7.1

Data for determination of COPPL T delivery 20°C		Tdesignh	A	B	C	D
7.1	Te	-10	-7	2	7	12
	PLR	100%	88%	54%	35%	15%
	DC		12,33	12,71	14,51	12,31
	CR		1,00	0,60	0,34	0,17
	P	14,01	12,33	7,97	5,21	3,67
	COP (part load)		2,87	4,62	7,07	6,70
	COP (full load)		2,87	4,00	4,70	5,70
	Fcop		1,00	1,16	1,50	1,18
Data to be provided for power and COP under full load cold source air		Te				
7.1	Te	Tm	-7	2	7	12
	Heating capacity $\Phi_{H,HP out}$ (kW)	35 °C	12,33	12,71	14,51	12,31
		45 °C	11,27	11,21	14,00	11,61
		55 °C	10,35	11,71	13,85	10,94
	COP	35 °C	2,87	4,00	4,70	5,70
		45 °C	2,61	3,11	3,65	4,61
55 °C		2,18	2,91	3,05	3,80	
DHW Power and COP data under full load		Te				
7.1	Te	Tm	7	15	20	35
	Heating capacity $\Phi_{H,HP out}$ (kW)	55 °C	13,85	12,35	13,76	16,51
	COP	55 °C	3,05	4,21	4,60	4,25

Terms and definitions

Tm = Delivery temperature

Tdesignh = A - Average design climate temperature (pursuant to UNI EN 14825)

A, B, C, D = names of the four conditions with which different outdoors air temperatures are associated (Te)

Te = Outdoors air temperature

PLR = part load ratio

DC = power under full load referred to the specified temperatures

CR = heat pump load factor

P = system power demand

COP' (full load) = COP under full load referred to the indicated outdoors air temperatures

COP' (partial load) = COP under partial load referred to the indicated outdoors air temperatures

fCOP = COP correction factor, as follows: COP' (full load) / COP (partial load)HP= heat pump

DHW = domestic hot water

# Data for the UNI/TS 11300 calculation

## SPHERA EVO 2.0 - Size 8.1

Data for determination of COPPL T delivery 20°C		Tdesignh	A	B	C	D
8.1	Te	-10	-7	2	7	12
	PLR	100%	88%	54%	35%	15%
	DC		13,82	14,30	16,01	15,20
	CR		1,00	0,59	0,34	0,16
	P	15,71	13,82	8,55	5,88	3,67
	COP (part load)		2,86	4,59	7,13	6,44
	COP (full load)		2,86	3,85	4,55	5,43
	Fcop		1,00	1,19	1,57	1,19
Data to be provided for power and COP under full load cold source air		Te				
8.1	Te	Tm	-7	2	7	12
	Heating capacity $\Phi_{H,HP out}$ (kW)	35 °C	13,82	14,30	16,01	15,20
		45 °C	12,35	13,79	16,01	14,55
		55 °C	11,23	13,32	16,00	13,91
	COP	35 °C	2,86	3,85	4,55	5,43
		45 °C	2,58	3,28	3,60	4,49
		55 °C	2,13	2,80	2,90	4,00
DHW Power and COP data under full load		Te				
8.1	Te	Tm	7	15	20	35
	Heating capacity $\Phi_{H,HP out}$ (kW)	55 °C	16,00	13,91	13,90	16,68
	COP	55 °C	2,90	4,39	4,86	4,49

### Terms and definitions

Tm = Delivery temperature

Tdesignh = A - Average design climate temperature (pursuant to UNI EN 14825)

A, B, C, D = names of the four conditions with which different outdoors air temperatures are associated (Te)

Te = Outdoors air temperature

PLR = part load ratio

DC = power under full load referred to the specified temperatures

CR = heat pump load factor

P = system power demand

COP' (full load) = COP under full load referred to the indicated outdoors air temperatures

COP' (partial load) = COP under partial load referred to the indicated outdoors air temperatures

fCOP = COP correction factor, as follows: COP' (full load) / COP (partial load)HP= heat pump

DHW = domestic hot water

The specified data refer to the nominal power values under the declared conditions

# Data for the UNI/TS 11300 calculation

## UNI/TS 11300 Part 3

SIZE	Test	Cooling capacity kW				EER			
		1	2	3	4	1	2	3	4
		100%	75%	50%	25%	100%	75%	50%	25%
<b>220-240V N 50Hz</b>									
	<b>2.1</b>	4,26	3,20	2,05	0,90	3,50	4,71	5,84	5,81
	<b>3.1</b>	6,25	4,59	2,96	1,35	3,09	4,43	6,17	7,40
	<b>4.1</b>	7,46	5,20	3,51	1,63	3,33	4,48	6,67	9,30
	<b>5.1</b>	9,10	6,43	4,25	1,94	3,09	4,26	6,73	10,48
	<b>6.1</b>	11,80	8,89	6,01	2,91	2,75	3,89	5,73	7,88
	<b>7.1</b>	12,86	9,40	6,29	2,91	2,55	3,78	5,71	7,88
	<b>8.1</b>	14,20	10,53	7,12	2,91	2,45	3,54	5,38	7,88

Reference conditions prescribed by UNI/TS 11300-3:

1. External air temperature B.S. 35 °C Refrigerated water temperature at the fancoil inlet/outlet 12/7 °C
2. External air temperature B.S. 30 °C Refrigerated water temperature at the fancoil outlet /7 °C
3. External air temperature B.S. 25 °C Refrigerated water temperature at the fancoil outlet /7 °C
4. External air temperature B.S. 20 °C Refrigerated water temperature at the fancoil outlet /7 °C

## DHW (Domestic Hot Water) settings and management

The unit is designed to be coupled to DHW storage boilers connected with the heater management kit and T5 probe.

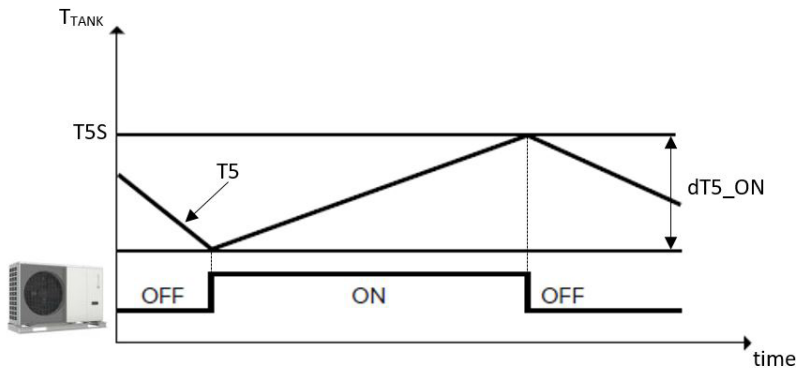

Logic dictates that there is a demand for DHW when the difference between the DHW set-point T5S and the temperature of the storage tank T5 is greater than or equal to the value dT5\_ON (default 10 °C, can be adjusted to 1-30)

Operation of the unit in DHW mode ends when  $T5 \geq T5S$  or when T5 reaches the maximum temperature for DHW in the heat pump T5stop, which is parameterised according to the outdoor temperature T4:

T4 [°C]	43÷40	40÷35	35÷30	30÷25	25÷20	20÷15	15÷10
2.1÷8.1	45	48	50	52	55	56	57

T4 [°C]	10÷5	5÷0	0÷-5	-5÷-10	-10÷-15	-15÷-20	<-20
2.1÷8.1	56	55	52	48	45	40	35

If there is a further demand for DHW beyond T5stop, the unit can activate the TBH boiler heater until setpoint T5S is reached.

In DHW mode, the heat pump delivers water at  $T_{wout} = T5 + dT1S5$ , where the parameter dT1S5 (default 10 °C, can be adjusted to 5-40) can be set from the HMI. Irrespective of how the parameter is set, the heat pump in Full Electric mode can deliver water up to 65 °C (60 °C for sizes 9.1-14.1), and up to 75 °C (70 °C for sizes 9.1-14.1) in hybrid systems in which there is an additional boiler driven by the unit itself.

The outdoor air temperature range T4 within which the heat pump can operate in DHW mode adjusting it between T4DHWMIN (default -10 °C, can be adjusted to between -25 and 30) and T4DHWMAX (default 43 °C, can be adjusted to 35-43). Outside the operating range set in this way, but within the generic operating range of the heat pump, the unit can produce DHW with the heater of the TBH DHW storage tank.

If there is simultaneous demand from DHW and the system, the former has priority as standard, but this can be changed at the HMI. However, the unit's logic controls several parameters and alternates between DHW and system operation in order to preserve comfort.

In particular, two controls can be activated, which process the maximum operating time of the unit in the system before switching to DHW t\_DHWHP\_RESTRICT (default 30min, can be adjusted to 10-600) and the maximum operating time of the unit in DHW mode before switching to system t\_DHWHP\_MAX (default 90min, can be adjusted to 10-600).

By default, when the compressor of the unit is stopped, the heat pump waits a minimum of 5 minutes for it to be reactivated.

Other functions related to the production of DHW are:

- DISINFECT: management of periodic antilegionella cycles (to be enabled, with logic as per the diagram)

# Main functions

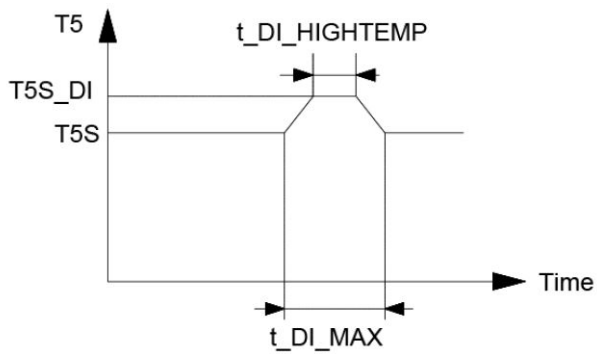
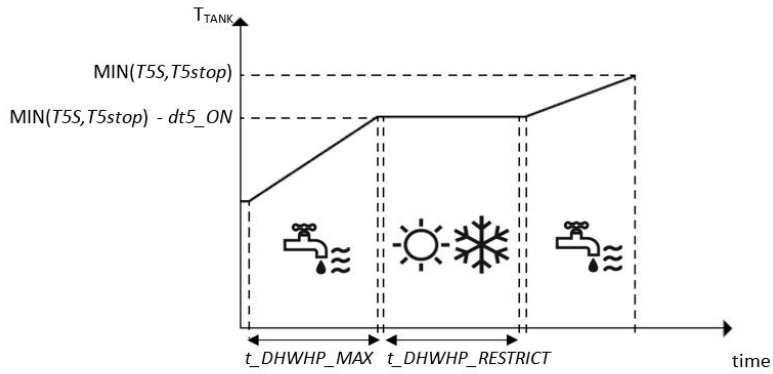

Parameters that can set on the HMI:  
 $T5S\_DI$  (standard: 65 - can be set from: 60-70)  
 temperature to which the unit must bring the DHW tank in anti-legionella mode  
 $t_{DI\_HIGHTEMP}$  (standard: 15 - can be set from: 5-60)  
 minutes during which the temperature  $T5S\_DI$  must be kept in anti-legionella mode  
 $t_{DI\_MAX}$  (standard: 210 - can be set from: 90-300)  
 maximum minutes during which the unit can remain in anti-legionella mode

Note: it is important to set the heater safety thermostat above the anti-legionella cycle temperature set point  $T5S\_DI$ , so that the cycle can be completed.

- FAST DHW: forces the unit and the heater of the TBH boiler to run in DHW mode up to the set-point
- TANK WATER: forces the heater of the TBH boiler to run in DHW mode, letting the unit of the system to work or act as a back-up in case of failure
- DHW PUMP: cycle programme for the DHW recirculation pump. The recirculation pump must be enabled at the HMI (parameter PUMP\_D TIMER), selecting whether it should also work during anti-legionella cycles (parameter PUMP\_D DISINFECT RUN), and setting the time of operation in minutes when activated in PUMP\_D RUNNING TIME (standard: 5 - can be set from: 5-120)

SPHERA EVO 2.0 provides a useful instrument for maximising savings, for hybrid systems with a gas boiler, through the EuroSwitch function. Based on the set price of natural gas and electricity, the heat pump will assign priority to its own operation rather than that of the boiler depending on its efficiency. The aim is to always use the most cost-effective heat source.

## Case 1 - Typical day in January - Radiators (supply temperature = 55 °C)

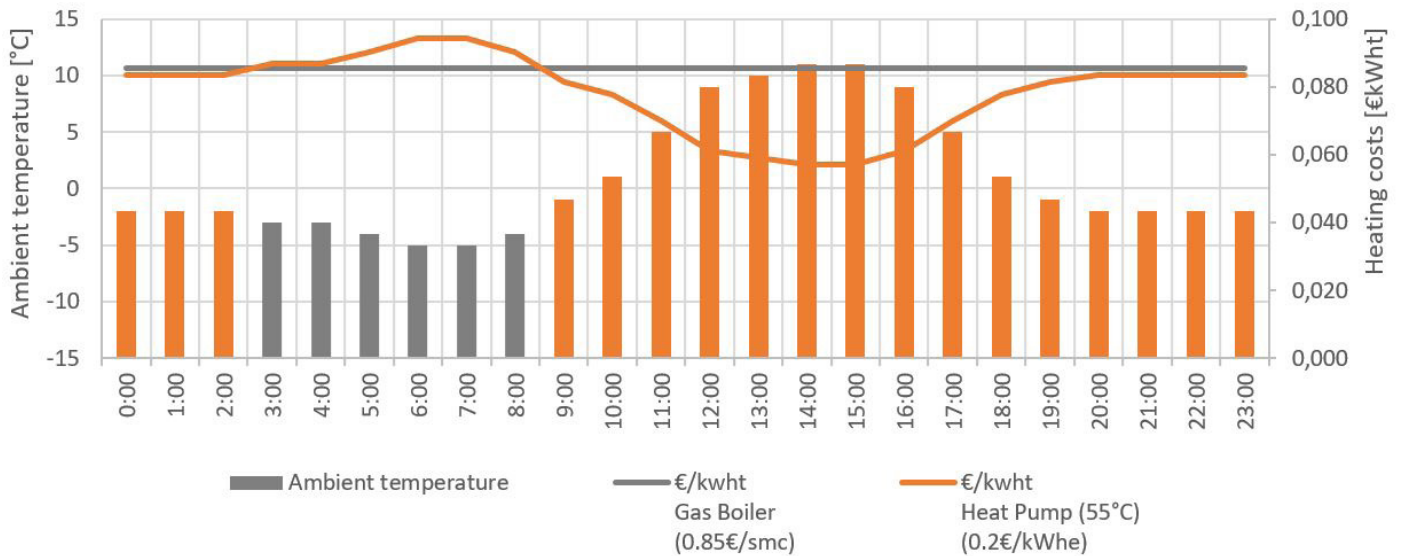

From 03:00am to 08:00am, heat will be produced by the boiler, while during other time slots, it will be produced by the heat pump.

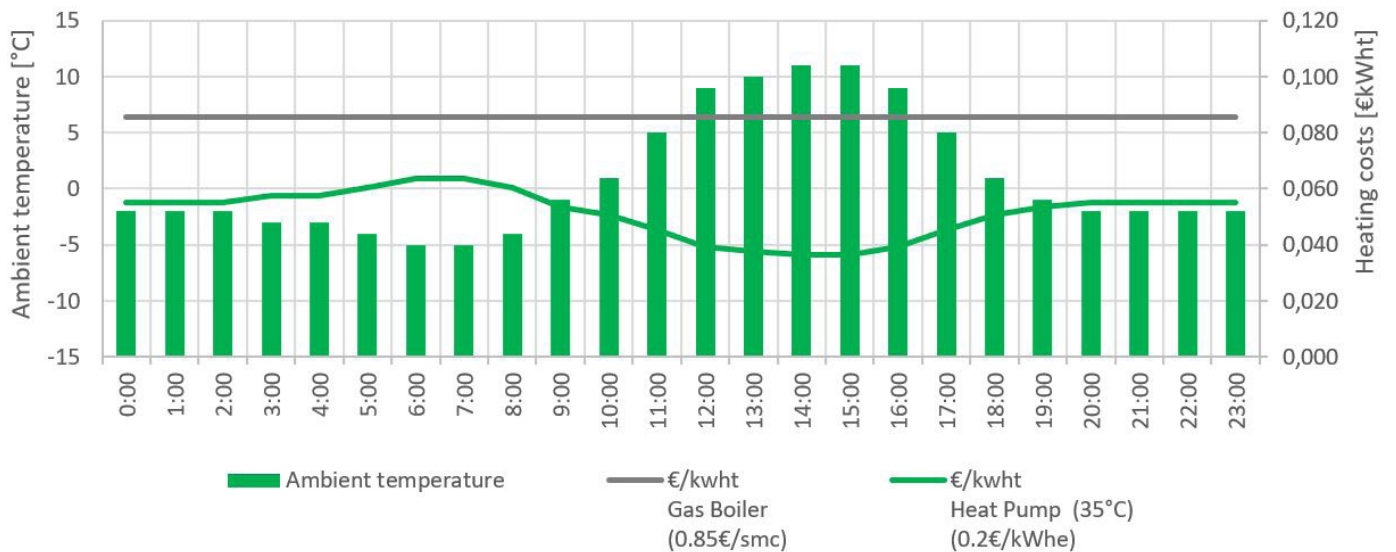

## Case 2 - Typical day in January - Radiant floor (supply temperature = 35 °C)

Heat will be produced by the heat pump during the whole day.

The graphs show the trend of the daily temperature and of the cost for thermal energy. The heat pump's efficiency varies according to the outdoor temperature and the water temperature, while the boiler has a fixed efficiency. The calculations consider an average cost of natural gas equal to 0.85 €/SCM and of electricity equal to 0.2 €/SCM.

# Management of units in cascade

---

Many applications require units to be installed as back-up for the main system or have loads that can change significantly during annual operation. Cascade operation allows connection of up to 6 units in parallel, running a Master unit and activating the Slave units when its own capacity is not sufficient to meet the load of the system, ensuring maximum reliability and efficiency of the system.

The system rotates operation of all of the units by counting the compressor's operating hours, so as to use them evenly. In the event of failure of a unit, including the Master, the system ensures continuity of service.

Cascade management is provided as standard by the logic of the units; it must be set with the dip-switches (Master or Slave unit) on the board and all Slave units must be connected with a serial to the HMI of the Master. The slave units are automatically addressed by the Master at start-up.

## SPHERA EVO 2.0 BOX (indoor unit)

DABGM0001\_00  
DATA/DATE 26/02/2025

DETTAGLIO A

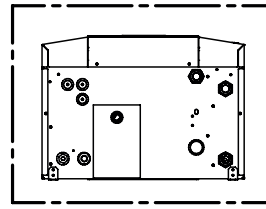
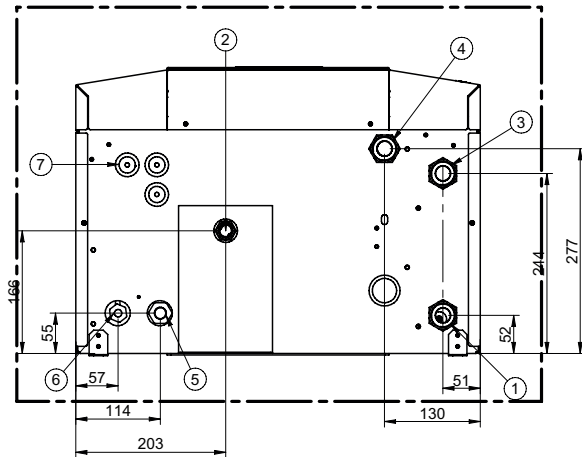

A

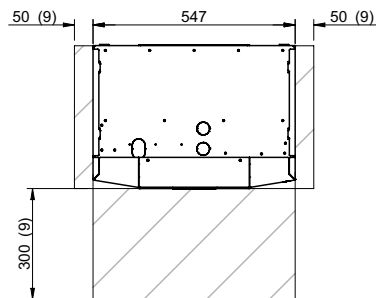
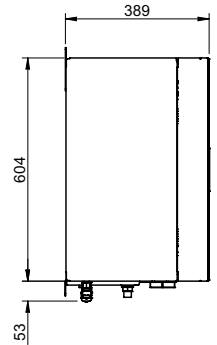
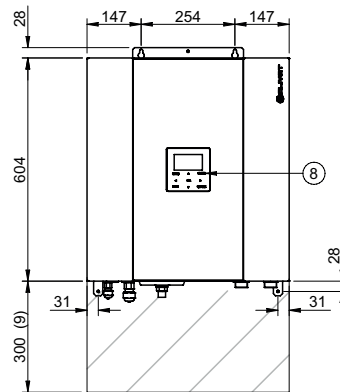

1. Electrical panel
2. Unit control keypad
3. Power input
4. Condensate drain
5. Functional spaces
6. DHW exchanger supply
7. DHW exchanger return
8. System outlet
9. System return
10. 5/8" SAE intake connection
11. 3/8" SAE liquid connection
12. Gas boiler inlet (optional)
13. Gas boiler outlet (optional)

SIZE		GABC	GBBC
Operation weight	kg	52	54
Shipping weight	kg	60	62

The presence of optional accessories may result in a substantial variation of the weights shown in the table.

# Dimensional drawings

## SPHERA EVO 2.0 (outdoor unit) - 2.1 ÷ 3.1

DAAQ80002\_REV03  
DATA/DATE 05/06/2023

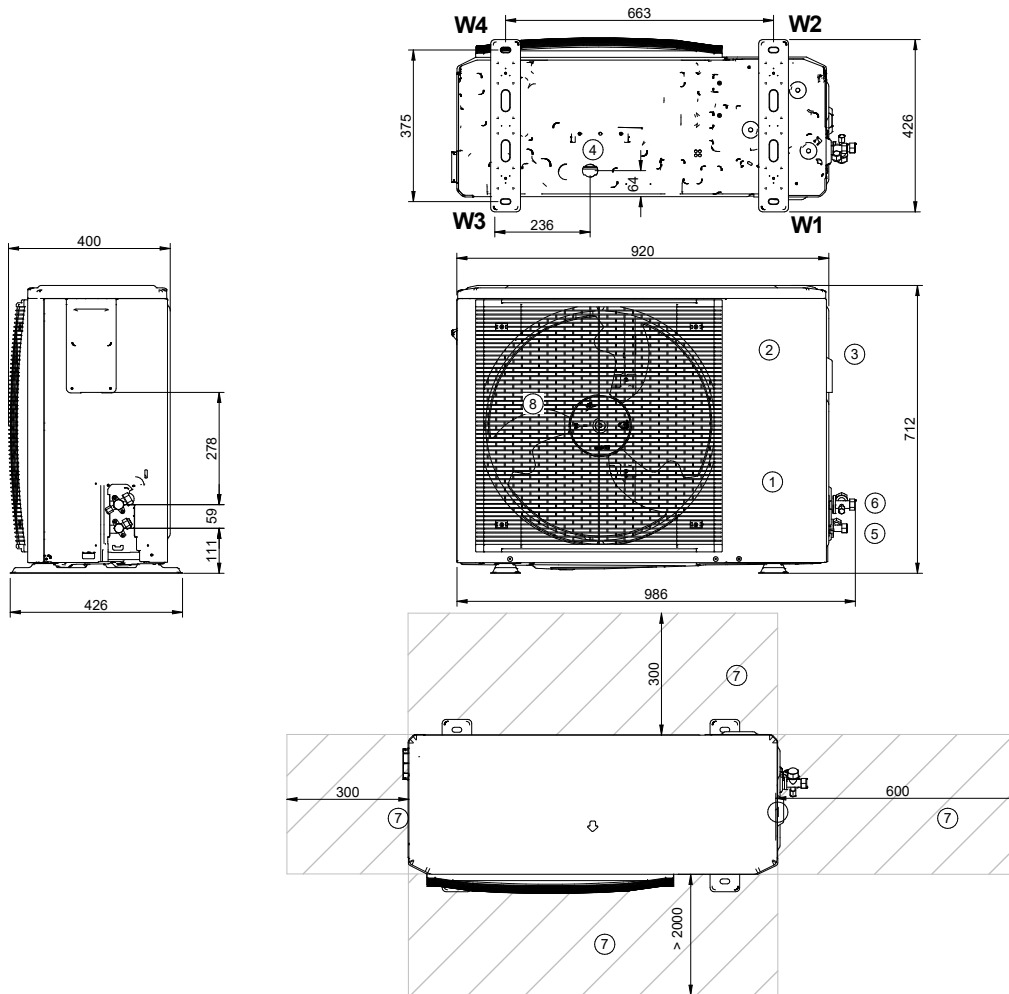

1. Compressor enclosure
2. Electrical panel
3. Power input
4. Condensate drain
5. Gas connections (1/4")
6. Gas connections (5/8")
7. Functional spaces
8. Electrical fan

SIZE		2.1	3.1
W1 Supporting Point	kg	23,9	23,9
W2 Supporting Point	kg	13,8	13,8
W3 Supporting Point	kg	12,9	12,9
W4 Supporting Point	kg	7,4	7,4
Operation weight	kg	58	58
Shipping weight	kg	64	64

The presence of optional accessories may result in a substantial variation of the weights shown in the table.

## SPHERA EVO 2.0 (outdoor unit) - 4.1 ÷ 8.1

DAAQ80001\_REV03  
DATA/DATE 05/06/2023

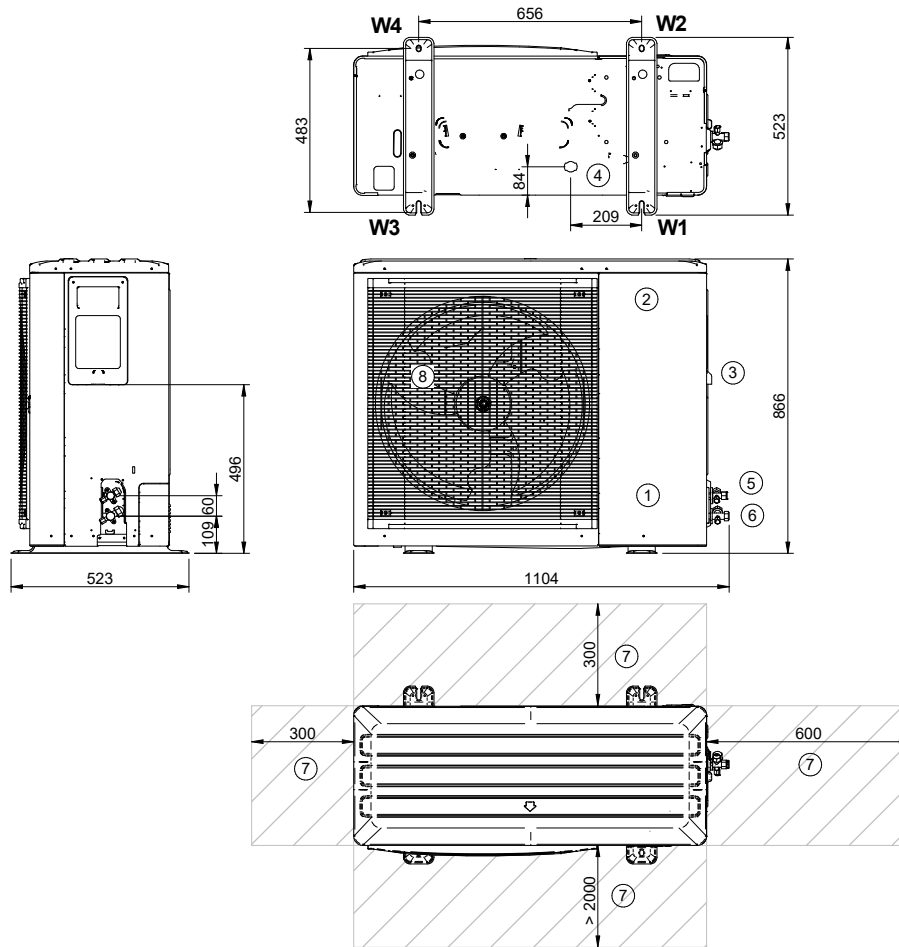

1. Compressor enclosure
2. Electrical panel
3. Power input
4. Condensate drain
5. Gas connections (3/8")
6. Gas connections (5/8")
7. Functional spaces
8. Electrical fan

SIZE		4.1 / 1Ph	5.1 / 1Ph	6.1 / 1Ph	6.1 / 3Ph	7.1 / 1Ph	7.1 / 3Ph	8.1 / 1Ph	8.1 / 3Ph
W1 Supporting Point		30	30	30,4	40,3	30,4	40,3	30,4	40,3
W2 Supporting Point		17,8	17,8	29,1	34,8	29,1	34,8	29,1	34,8
W3 Supporting Point		18,4	18,4	18,6	19,8	18,6	19,8	18,6	19,8
W4 Supporting Point		10,9	10,9	17,9	17,1	17,9	17,1	17,9	17,1
Operation weight	kg	77	77	96	112	96	112	96	112
Shipping weight	kg	88	88	110	125	110	125	110	125

The presence of optional accessories may result in a substantial variation of the weights shown in the table.

Page intentionally left blank

Page intentionally left blank

Page intentionally left blank

FOR 35 YEARS WE HAVE BEEN OFFERING  
SOLUTIONS TO ENSURE SUSTAINABLE  
COMFORT AND THE WELL-BEING OF PEOPLE  
AND THE ENVIRONMENT

[www.clivet.com](http://www.clivet.com)

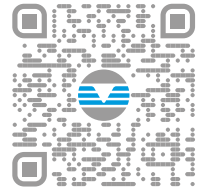

sale and assistance

Inizio validità: 2021 - (revisione 10/2024)  
BT21F059GB-10



**CLIVET S.p.A.**

Via Camp Lonc 25, Z.I. Villapaiera 32032 - Feltre (BL) - Italy  
Tel. +39 0439 3131 - [info@clivet.it](mailto:info@clivet.it)

**CLIVET GMBH**

Hummelsbütteler Steindamm 84,  
22851 Norderstedt, Germany  
Tel. +49 40 325957-0 - [info.de@clivet.com](mailto:info.de@clivet.com)

**Clivet Group UK LTD**

Units F5 & F6 Railway Triangle,  
Portsmouth, Hampshire PO6 1TG  
Tel. +44 02392 381235 -  
[Enquiries@Clivetgroup.co.uk](mailto:Enquiries@Clivetgroup.co.uk)

**CLIVET LLC**

Office 508-511, Elektrozavodskaya st. 24,  
Moscow, Russian Federation, 107023  
Tel. +7495 6462009 - [info.ru@clivet.com](mailto:info.ru@clivet.com)

**CLIVET MIDEAST FZCO**

Dubai Silicon Oasis (DSO) Headquarter Building,  
Office EG-05, P.O Box-342009, Dubai, UAE  
Tel. +9714 3208499 - [info@clivet.ae](mailto:info@clivet.ae)

**Clivet South East Europe d.o.o.**

Jarušćica 9b  
10000, Zagreb, Croatia  
Tel. +3851 222 8784 - [info.see@clivet.com](mailto:info.see@clivet.com)

**CLIVET France SAS**

6 Allée Kepler,  
77420 Champs-sur-Marne  
France  
mail: [info.fr@clivet.com](mailto:info.fr@clivet.com)  
Tel: +33 1 88 60 99 40

**Clivet Airconditioning Systems Pvt Ltd**

Office No.501 & 502,5th Floor, Commercial -1,  
Kohinoor City, Old Premier Compound, Off LBS  
Marg, Kirod Road, Kurla West, Mumbai  
Maharashtra 400070, India  
Tel. +91 22 30930200 - [sales.india@clivet.com](mailto:sales.india@clivet.com)