

## MONOSplit

### CRISTALLO 20M - 70M

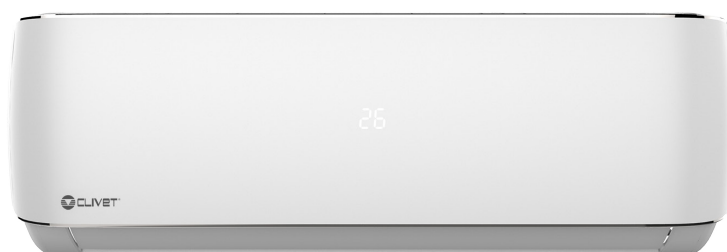

### ESSENTIAL 2 20M - 70M



<b>1. Specifications .....</b>	<b>3</b>
1. Model Reference	
2. General Specifications	
3. Dimensional Drawings	
4. Electrical Wiring Diagrams	
5. Refrigerant Cycle Diagrams	
6. Capacity Tables	
7. Noise Criterion Curves	
8. Electrical Characteristics	
<b>2. Product Features .....</b>	<b>36</b>
1. Operation Modes and Functions	
2. Remote Controller Functions	
<b>3. Installation .....</b>	<b>45</b>
1. Installation Overview	
2. Location Selection	
3. Indoor Unit Installation	
4. Outdoor Unit Installation	
5. Refrigerant Pipe Installation	
6. Vacuum Drying and Leakage Checking	
7. Additional Refrigerant Charge	
8. Electrical and Gas Leak Checks	
9. Test Operation	

---

# Specifications

## Contents

1.	Model Reference.....	4
2.	General Specifications.....	5
3.	Dimensional Drawings.....	9
4.	Electrical Wiring Diagrams.....	13
5.	Refrigerant Cycle Diagrams.....	17
6.	Capacity Tables.....	19
7.	Noise Criterion Curves.....	31
8.	Electrical Characteristics.....	35

---

## 1. Model Reference

Refer to the following table to determine the specific indoor and outdoor unit model number of your purchased equipment.

Outdoor Unit Model	Indoor Unit Model	Capacity (Btu/h)	Power Supply
MM2-Y 27M / ML3-Y 27M	IM2-XY 20M / IL3-XY 20M IM2-XY 27M / IL3-XY 27M	09k	1Φ, 220~240V~, 50Hz
MM2-Y 35M / ML3-Y 35M	IM2-XY 35M / IL3-XY 35M	12k	
MM2-Y 53M / ML3-Y 53M	IM2-XY 53M / IL3-XY 53M	18k	
MM2-Y 70M / ML3-Y 70M	IM2-XY 70M / IL3-XY 70M	24k	

## 2. General Specifications

Model		IM2-XY 27M / IL3-XY 27M	IM2-XY 35M / IL3-XY 35M
Power supply		V- Ph-Hz	220~240-1-50
Max. input consumption		W	2150
Max. current		A	10
Compressor	Model		KSK103D33UEZ3
	Type		ROTARY
	Brand		GMCC
	Capacity	W	2035/3255
	Input	W	325/826
	Rated current(RLA)	A	2.40/5.65
	Locked rotor Amp(LRA)	A	/
	Thermal protector		/
	Thermal protector position		/
	Capacitor	uF	/
Refrigerant oil/oil charge		ml	ESTER OIL VG74 310
Indoor fan motor	Model		ZKFP-20-8-6-7
	Input	W	50
	Output	W	20
	Capacitor	uF	/
	Speed(Hi/Mi/Lo)	r/min	1150/850/700
Indoor coil	Number of rows		2
	Tube pitch(a)x row pitch(b)	mm	21x13.37
	Fin spacing	mm	1.3
	Fin type (code)		Hydrophilic aluminum
	Tube outside dia.and type	mm	Φ7,Inner groove tube
	Coil length x height x width	mm	525x84x13.37+525x105x26.74+525x105x26.74
Indoor air flow (Hi/Mi/Lo)		m <sup>3</sup> /h	416/309/230
Indoor sound pressure level		dB(A)	39/32/26
Indoor sound power level		dB(A)	56
Indoor unit	Dimension(W*D*H)	mm	722x187x290
	Packing (W*D*H)	mm	790x270x375
	Net/Gross weight	Kg	7.3/9.7
Outdoor fan motor	Model		ZKFN-34-10-1
	Input	W	99.6
	Output	W	34
	Capacitor	uF	/
	Speed	r/min	760/450
Outdoor coil	Number of rows		1.0
	Tube pitch(a)x row pitch(b)	mm	21x22
	Fin spacing	mm	1.3
	Fin type (code)		Hydrophilic aluminum
	Tube outside dia.and type	mm	Φ7,Inner groove tube
	Coil length x height x width	mm	740x462x22
Outdoor air flow (Hi/Mi/Lo)		m <sup>3</sup> /h	1750
Outdoor sound pressure level		dB(A)	56
Outdoor sound power level		dB(A)	63
Outdoor unit	Dimension(W*D*H)	mm	720x270x495
	Packing (W*D*H)	mm	835x300x540
	Net/Gross weight	Kg	23.2/25.0

Refrigerant	Type		R32	R32
	GWP		675	675
	Charged quantity	Kg	0.55	0.55
Design pressure		MPa	4.3/1.7	4.3/1.7
Refrigerant piping	Liquid side/ Gas side	mm(inch)	Φ6.35/Φ9.52(1/4"/3/8")	Φ6.35/Φ9.52(1/4"/3/8")
	Max. refrigerant pipe length	m	25	25
	Max. difference in level	m	10	10
Connection wiring			1.5x5	1.5x5
Plug type			no-plug	no-plug
Thermostat type			Remote Control	Remote Control
Operation temperature			17~30	17~30
Ambient temperature	Indoor(cooling/ heating)	°C	17~32/0~30	17~32/0~30
	Outdoor(cooling/heating)	°C	-15~50/-15~30	-15~50/-15~30
Qty/per 20' /40' /40'HQ			138/282/312	130/276/302

## Notes:

1) Capacities are based on the following conditions:

Cooling(T1): - Indoor Temperature 27°C(80.6°F) DB /19 °C(66.2°F) WB  
 -Outdoor Temperature 35 °C(95°F) DB /24 °C(75.2°F) WB  
 -Interconnecting Piping Length 5m  
 - Level Difference of Zero.

Heating: - Indoor Temperature 20°C(68°F) DB / 15°C(59°F) WB  
 -Outdoor Temperature 7°C(44.6°F) DB / 6°C(42.8°F) WB  
 - Interconnecting Piping Length 5 m  
 - Level Difference of Zero.

2) Capacities are Net Capacities.

3) Due to our policy of innovation some specifications may be changed without notification.

Model			IM2-XY 53M / IL3-XY 53M	IM2-XY 70M / IL3-XY 70M
Power supply		V- Ph-Hz	220~240-1-50	220~240-1-50
Max. input consumption		W	2500	3700
Max. current		A	13	19
Compressor	Model		KSN140D21UFZ	KTM240D57UMT
	Type		ROTARY	Twin-ROTARY
	Brand		GMCC	GMCC
	Capacity	W	4385	7740
	Input	W	1140	2085
	Rated current(RLA)	A	7.50	9.45
	Locked rotor Amp(LRA)	A	/	/
	Thermal protector		/	/
	Thermal protector position		/	/
	Capacitor	uF	/	/
	Refrigerant oil/oil charge	ml	ESTER OIL VG74 440	ESTER OIL VG74 670
Indoor fan motor	Model		ZKFP-30-8-3-10	ZKFP-58-8-1-5
	Input	W	36.0	58.0
	Output	W	30	58
	Capacitor	uF	/	/
	Speed(Hi/Mi/Lo)	r/min	1150/800/700	1150/900/700
Indoor coil	Number of rows		2	2
	Tube pitch(a)x row pitch(b)	mm	21x13.37	21x13.37
	Fin spacing	mm	1.2	1.3
	Fin type (code)		Hydrophilic aluminum	Hydrophilic aluminum
	Tube outside dia.and type	mm	Φ7,Inner groove tube	Φ7,Inner groove tube
	Coil length x height x width	mm	750x210x26.74+750x126x26.74	820x210x26.74+820x126x26.74
	Number of circuits		4	4
Indoor air flow (Hi/Mi/Lo)		m <sup>3</sup> /h	730/500/420	1020/830/640
Indoor sound pressure level		dB(A)	43/33.5/28	47/41.5/30.5
Indoor sound power level		dB(A)	58	63
Indoor unit	Dimension(W*D*H)	mm	965x215x319	1080x226x335
	Packing (W*D*H)	mm	1045x305x410	1155x415x320
	Net/Gross weight	Kg	10.9/14.2	13.7/17.3
Outdoor fan motor	Model		ZKFN-34-10-1	ZKFN-80-8-3
	Input	W	99.6	88
	Output	W	34	80
	Capacitor	uF		/
	Speed	r/min	760/650	830/550
Outdoor coil	Number of rows		2.0	1.6
	Tube pitch(a)x row pitch(b)	mm	21x22	21x22
	Fin spacing	mm	1.3	1.3
	Fin type (code)		Hydrophilic aluminum	Hydrophilic aluminum
	Tube outside dia.and type	mm	Φ7,Inner groove tube	Φ7,Inner groove tube
	Coil length x height x width	mm	860x504x44	900x609x44
	Number of circuits		4	5
Outdoor air flow (Hi/Mi/Lo)		m <sup>3</sup> /h	2100	3500
Outdoor sound pressure level		dB(A)	55.5	60.5
Outdoor sound power level		dB(A)	64	66
Outdoor unit	Dimension(W*D*H)	mm	805x330x554	890x342x673
	Packing (W*D*H)	mm	915x370x615	995x398x740
	Net/Gross weight	Kg	33.5/36.1	43.9/46.9

Refrigerant	Type		R32	R32
	GWP		675	675
	Charged quantity	Kg	1.1	1.45
Design pressure		MPa	4.3/1.7	4.3/1.7
Refrigerant piping	Liquid side/ Gas side	mm(inch)	Φ6.35/Φ12.7(1/4"/1/2")	Φ9.52/Φ15.9(1/2"/5/8")
	Max. refrigerant pipe length	m	30	50
	Max. difference in level	m	20	25
Connection wiring			1.5x5	2.5x5
Plug type			no-plug	no-plug
Thermostat type			Remote Control	Remote Control
Operation temperature			17~30	17~30
Ambient temperature	Indoor(cooling/ heating)	°C	17~32/0~30	17~32/0~30
	Outdoor(cooling/heating)	°C	-15~50/-15~30	-15~50/-15~30
Qty/per 20' /40' /40'HQ			86/174/204	64/134/156

## Notes:

1) Capacities are based on the following conditions:

Cooling(T1): - Indoor Temperature 27°C(80.6°F) DB /19 °C(66.2°F) WB  
 -Outdoor Temperature 35 °C(95°F) DB /24 °C(75.2°F) WB  
 -Interconnecting Piping Length 5m  
 - Level Difference of Zero.

Heating: - Indoor Temperature 20°C(68°F) DB / 15°C(59°F) WB  
 -Outdoor Temperature 7°C(44.6°F) DB / 6°C(42.8°F) WB  
 - Interconnecting Piping Length 5 m  
 - Level Difference of Zero.

2) Capacities are Net Capacities.

3) Due to our policy of innovation some specifications may be changed without notification.

### 3. Dimensional Drawings

#### 3.1 Indoor Unit

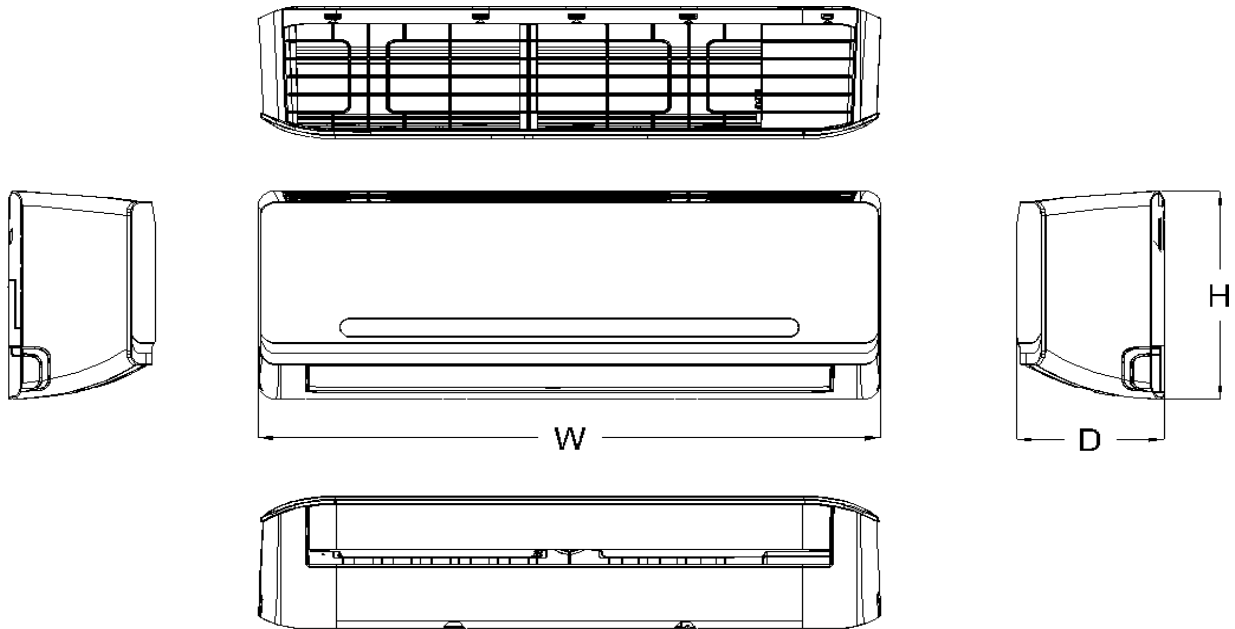

SIZE	Unit	W	D	H
20M/27M	mm	722	187	290
	inch	28.43	7.36	11.42
35M	mm	802	189	297
	inch	31.57	7.44	11.69
53M	mm	965	215	319
	inch	37.99	8.46	12.56
70M	mm	1080	226	335
	inch	42.52	8.90	13.19

### 3.2 Outdoor Unit

MM2-Y 27M / ML3-Y 27M

MM2-Y 35M / ML3-Y 35M

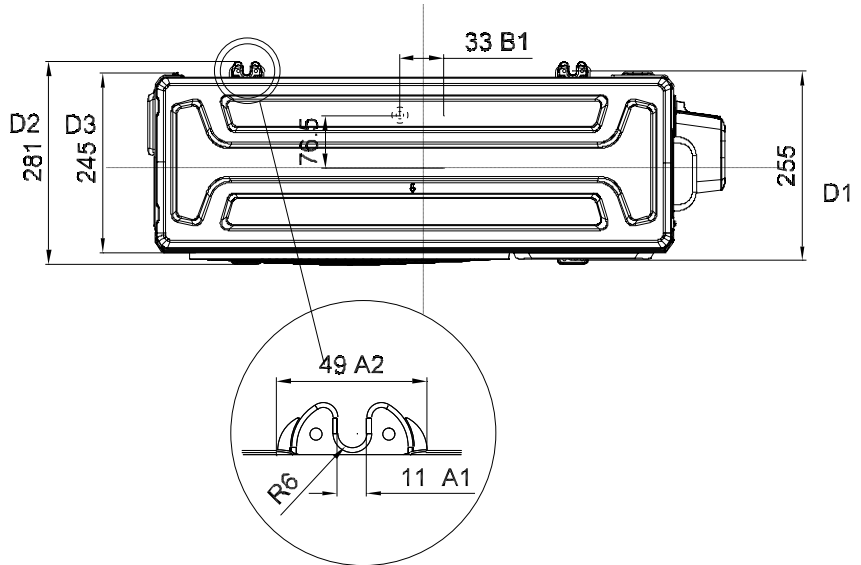
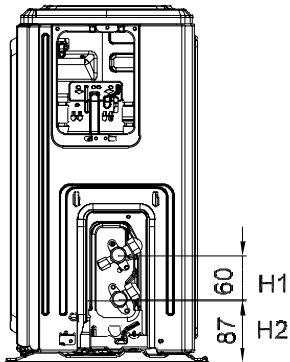
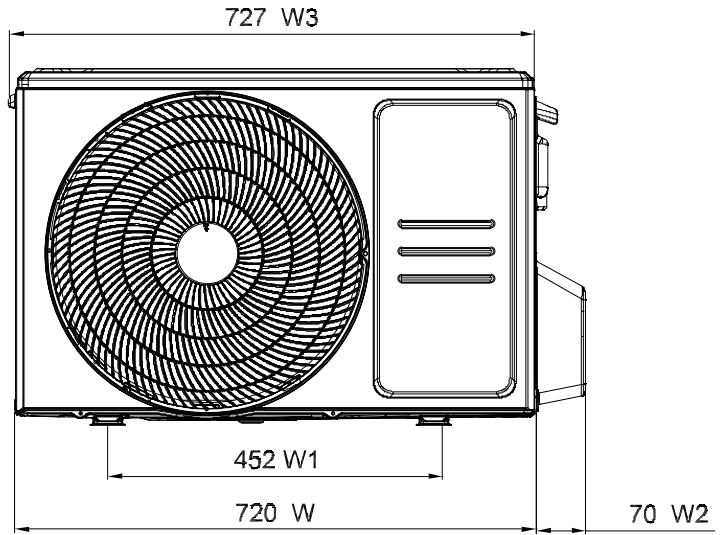
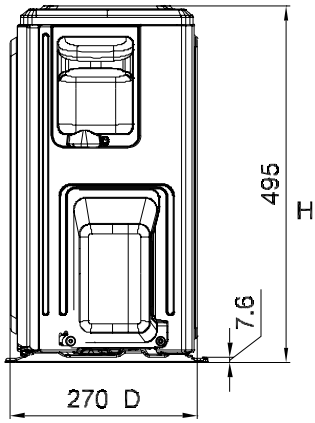

MM2-Y 53M / ML3-Y 53M

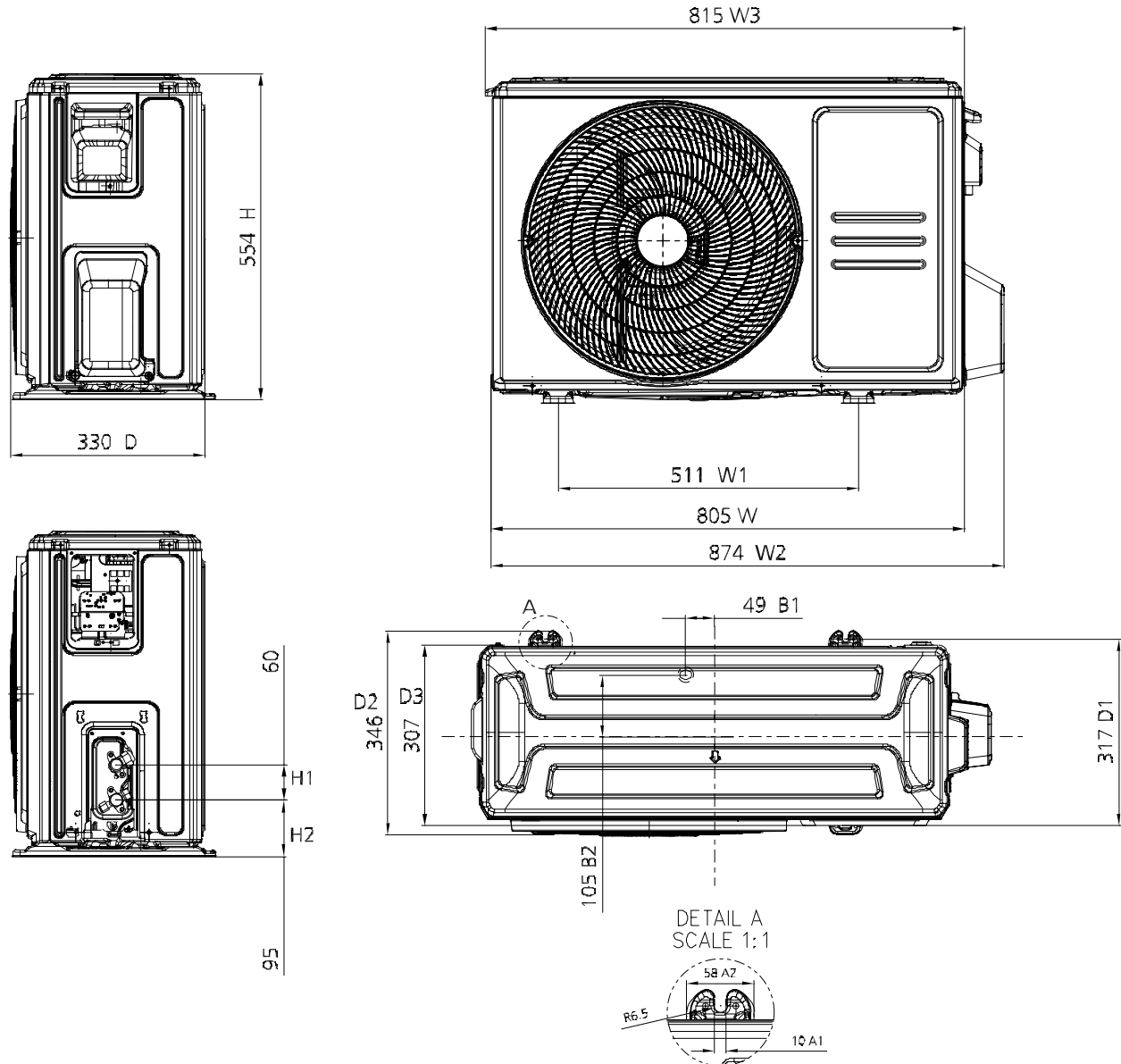

MM2-Y 70M / ML3-Y 70M

Specifications

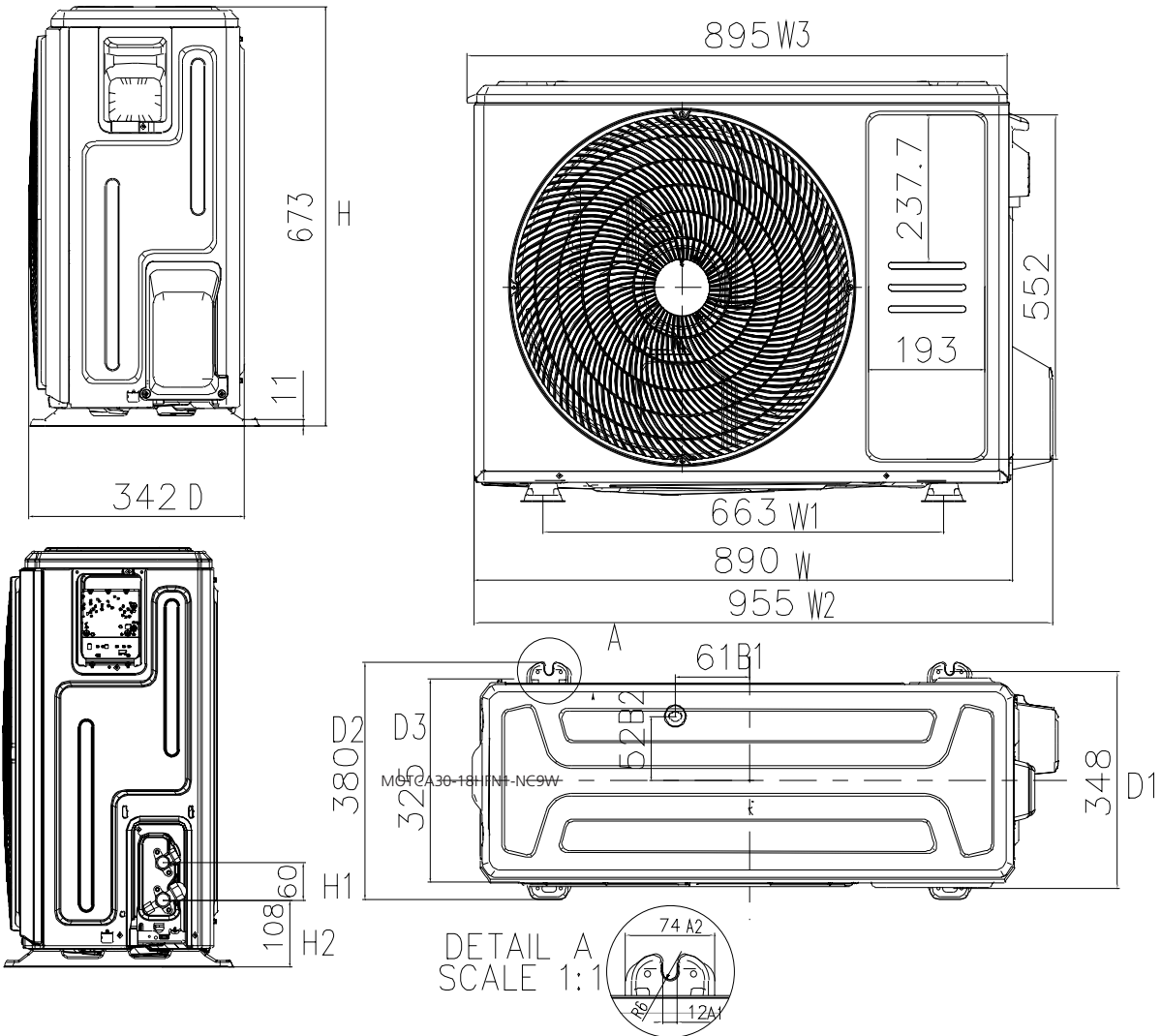

## 4. Electrical Wiring Diagrams

### 4.1 Indoor unit

Abbreviation	Paraphrase
Y/G	Yellow-Green Conductor
ION	Positive and Negative Ion Generator
CAP	Capacitor
PLASMA	Electronic Dust Collector
L	LIVE
N	NEUTRAL
Heater	The Electric Heating Belt of Indoor Unit
T1	Indoor Room Temperature
T2	Coil Temperature of Indoor Heat Exchanger

Indoor Unit IM2-XY 20M-70M / IL3-XY 20M-70M

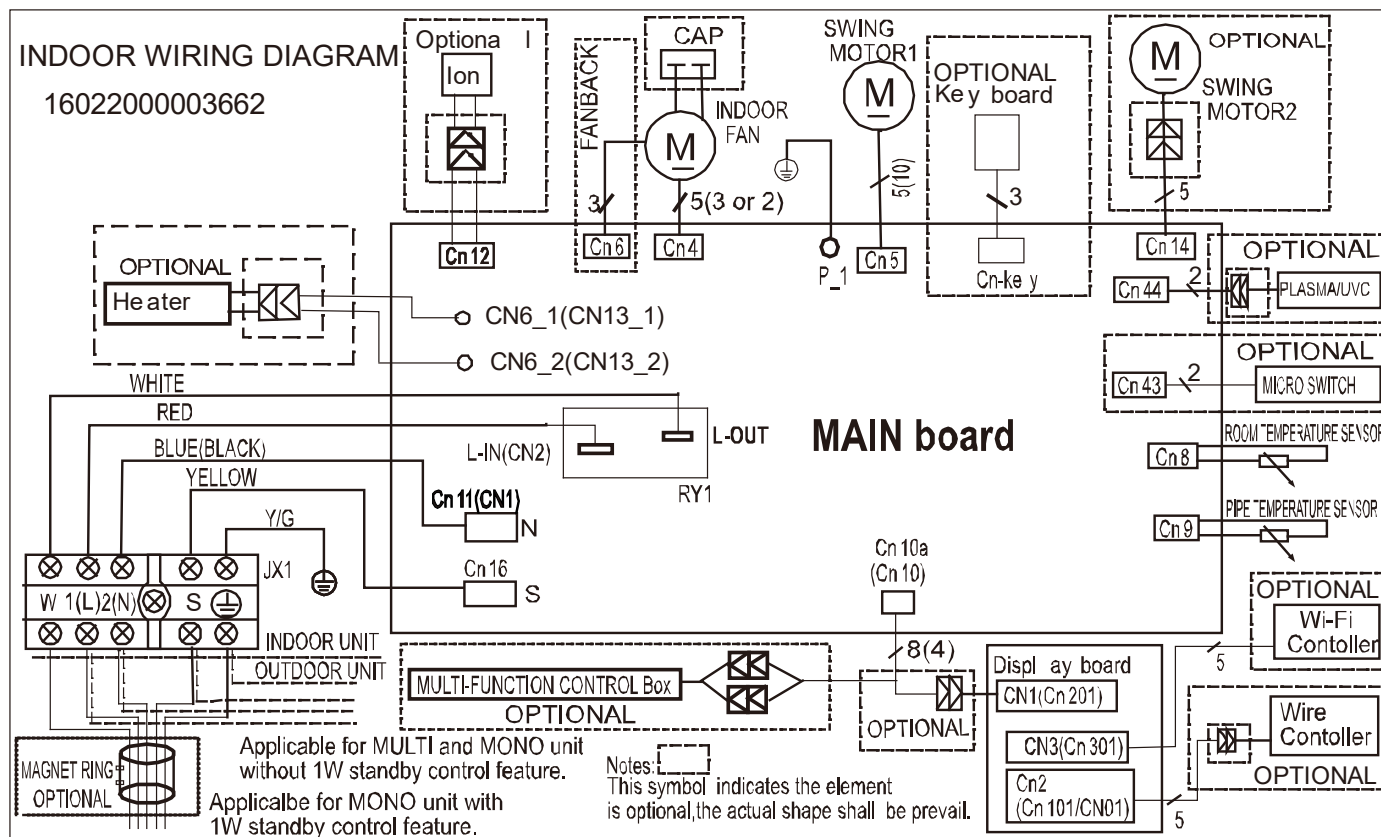

## 4.2 Outdoor Unit

Abbreviation	Paraphrase
4-WAY	Gas Valve Assembly/4-WAY VALVE
AC-FAN	Alternating Current FAN
DC-FAN	Direct Current FAN
CT1	AC Current Detector
COMP	Compressor
T3	Coil Temperature of Condenser
T4	Outdoor Ambient Temperature
TH	Compressor Suction Temperature
TP	Compressor Discharge Temperature
EEV	Electric Expansive Valve
L-PRO	Low Pressure Switch
H-PRO	High Pressure Switch

Notes:    16022000019533

This symbol indicates the element is optional, the actual shape shall be prevail.

This symbol indicates the element exist various locations.

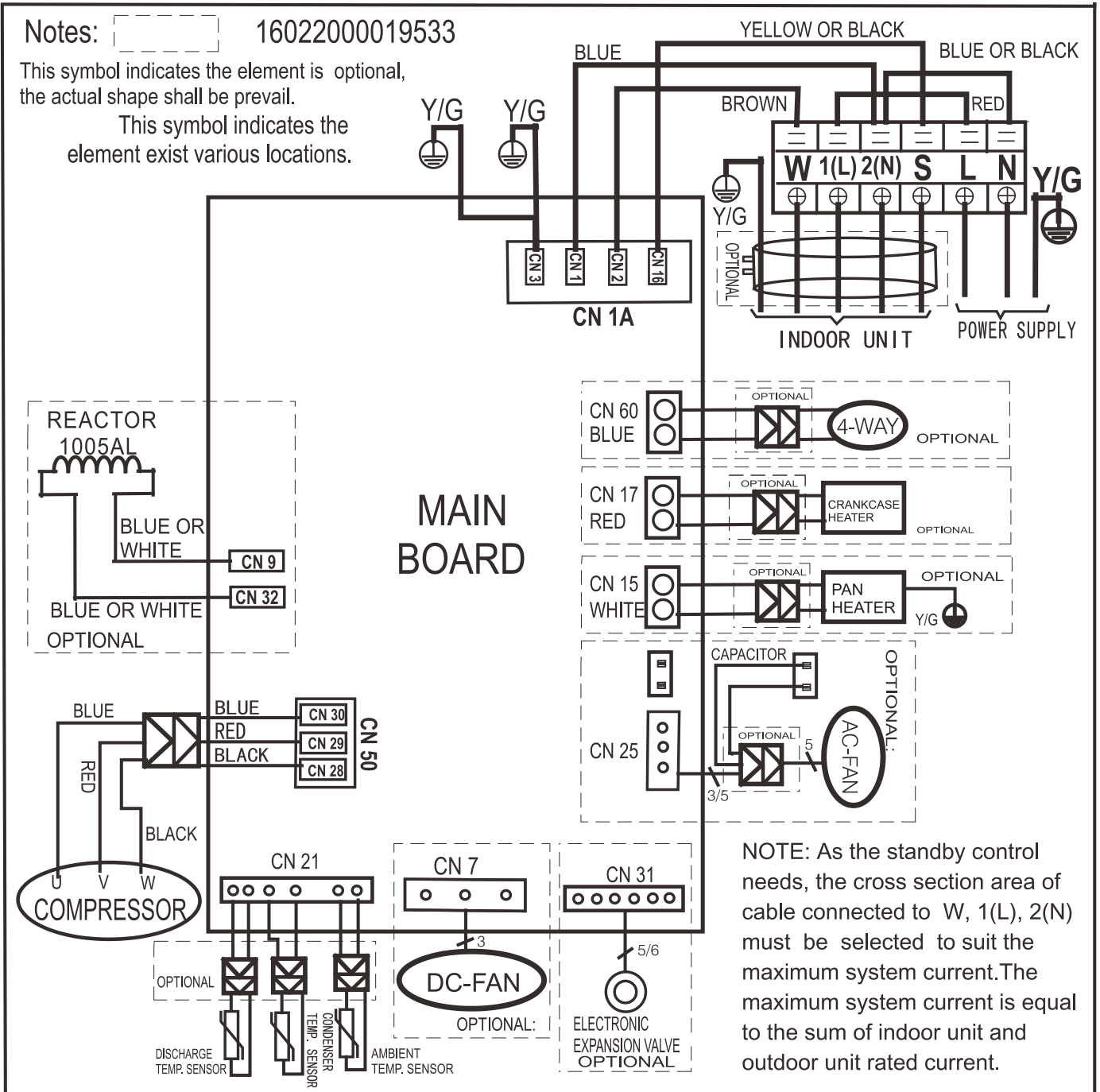

Outdoor Unit MM2-Y 70M / ML3-Y 70M

Notes:

This symbol indicates the element is optional, the actual shape shall prevail.

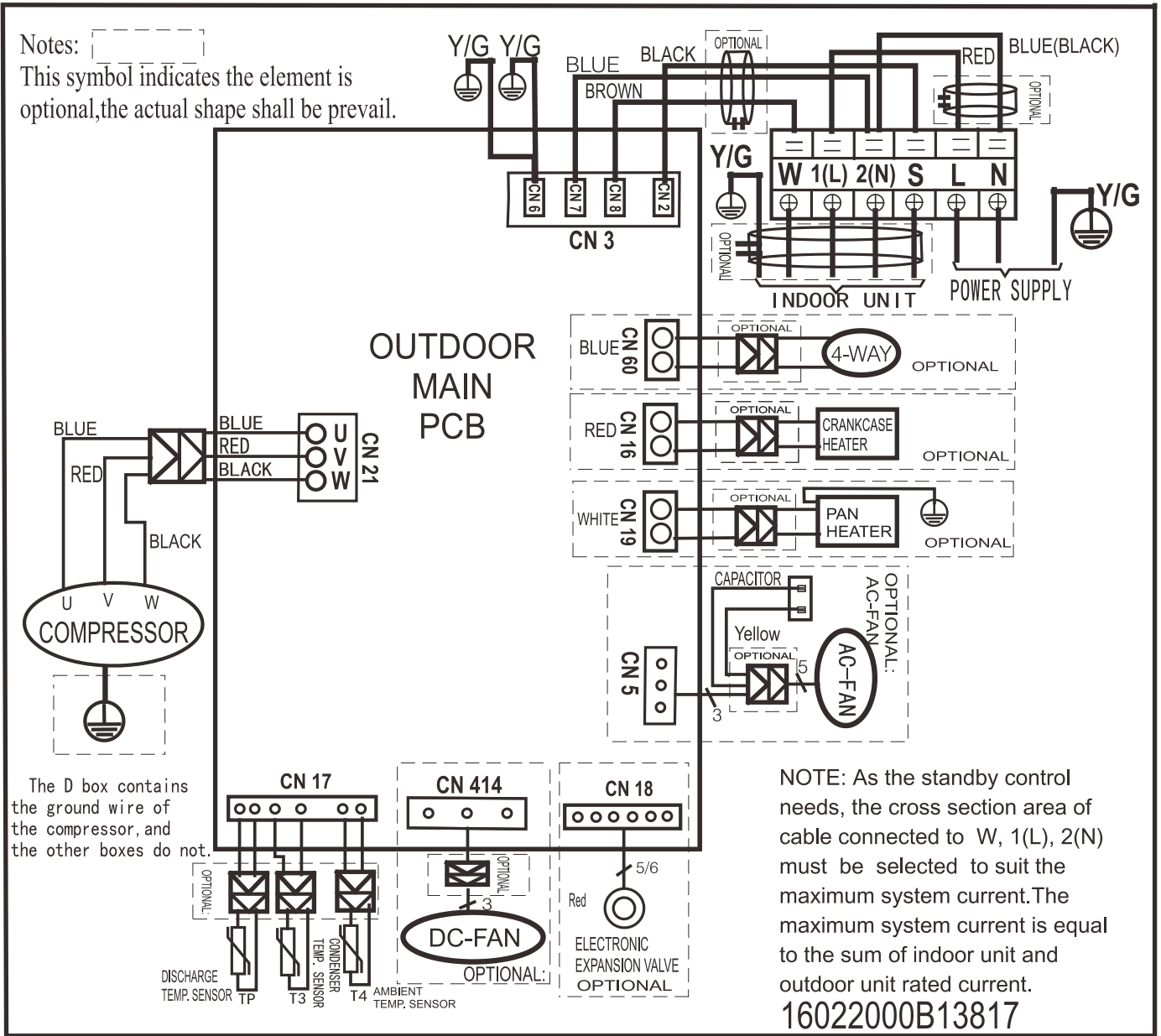

## 5. Refrigerant Cycle Diagrams

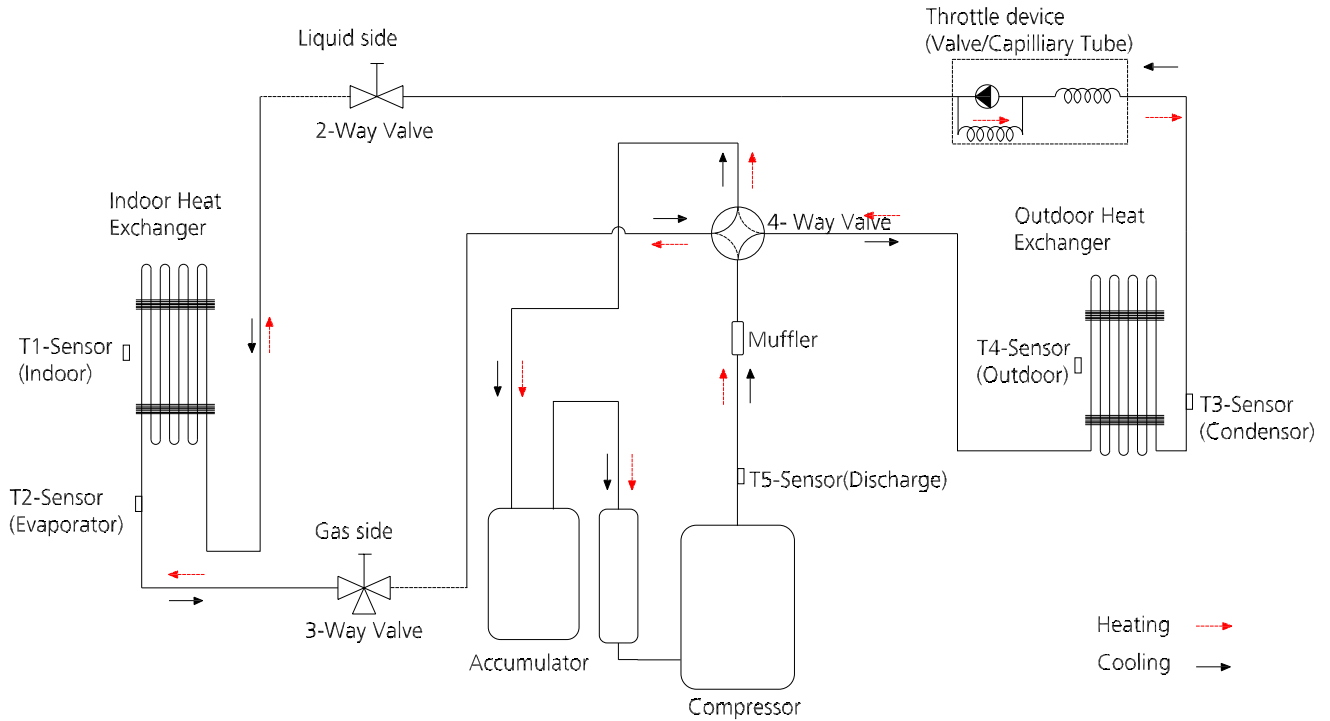

SIZE	Pipe Size (Diameter:ø) mm(inch)		Piping length (m/ft)		Elevation (m/ft)		Additional Refrigerant
	Gas	Liquid	Rated	Max.	Rated	Max.	
27M	9.52(3/8)	6.35(1/4)	5/16.4	25/82	0	10/32.8	12g/m (0.13oz/ft)
35M	12.7(1/2)	6.35(1/4)	5/16.4	25/82	0	10/32.8	
53M	12.7(1/2)	6.35(1/4)	5/16.4	30/98.4	0	20/65.6	

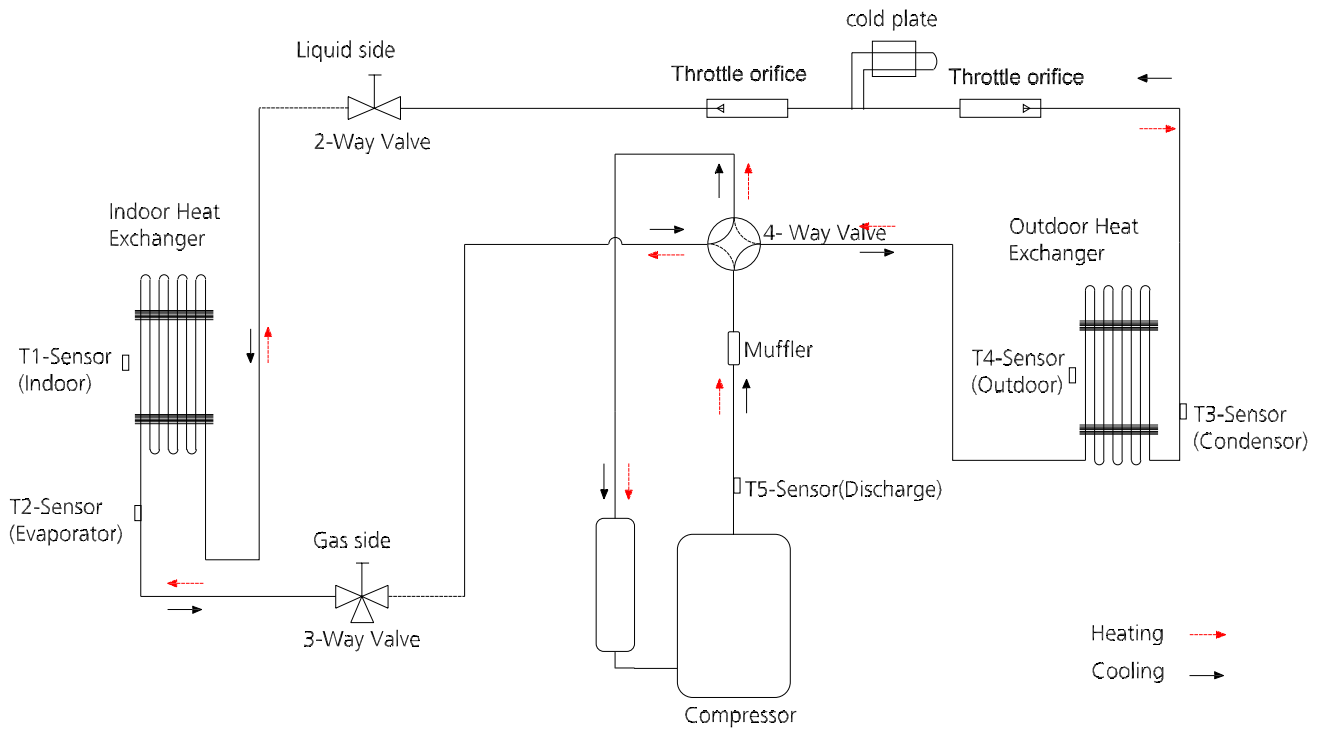

Size	Pipe Size (Diameter:ø) mm(inch)		Piping length (m/ft)		Elevation (m/ft)		Additional Refrigerant
	Gas	Liquid	Rated	Max.	Rated	Max.	
70M	15.9(5/8)	9.52(3/8)	5/16.4	50/164	0	25/82	24g/m (0.26oz/ft)

# 6. Capacity Tables

## 6.1 Cooling

		MM2-Y 27M / ML3-Y 27M + IM2-XY 20M-27M / IL3-XY 20M-27M																
INDOOR AIRFLOW (CMH)	OUTDOOR DB (C)	ID WB (C)	16.0				18.0				19.0				22.0			
		ID DB (C)	23.0	25.0	27.0	29.0	23.0	25.0	27.0	29.0	23.0	25.0	27.0	29.0	23.0	25.0	27.0	29.0
230	-15	TC	2.75	2.73	2.73	2.73	2.89	2.95	2.95	2.95	2.97	2.97	2.97	2.97	3.14	3.14	3.14	3.14
		S/T	0.66	0.71	0.76	0.82	0.55	0.60	0.66	0.70	0.50	0.55	0.61	0.66	0.39	0.43	0.48	0.53
		PI	0.50	0.50	0.50	0.50	0.50	0.50	0.50	0.50	0.50	0.50	0.50	0.50	0.50	0.49	0.49	0.49
	-10	TC	2.73	2.72	2.72	2.72	2.87	2.94	2.94	2.94	2.95	2.95	2.95	2.95	3.13	3.13	3.13	3.13
		S/T	0.66	0.72	0.77	0.82	0.55	0.61	0.66	0.71	0.50	0.55	0.61	0.66	0.39	0.44	0.49	0.53
		PI	0.50	0.50	0.50	0.50	0.50	0.50	0.50	0.50	0.50	0.50	0.50	0.50	0.50	0.49	0.49	0.49
	-5	TC	2.71	2.70	2.70	2.70	2.86	2.92	2.92	2.92	2.94	2.94	2.94	2.94	3.12	3.12	3.12	3.12
		S/T	0.66	0.72	0.77	0.83	0.56	0.61	0.66	0.71	0.51	0.56	0.61	0.66	0.39	0.44	0.49	0.54
		PI	0.50	0.50	0.50	0.50	0.50	0.50	0.50	0.50	0.50	0.50	0.50	0.50	0.50	0.49	0.49	0.49
	0	TC	2.70	2.69	2.69	2.69	2.85	2.91	2.91	2.91	2.93	2.93	2.93	2.93	3.12	3.12	3.12	3.12
		S/T	0.67	0.73	0.77	0.83	0.56	0.61	0.67	0.72	0.51	0.56	0.62	0.67	0.39	0.44	0.49	0.54
		PI	0.50	0.50	0.50	0.50	0.50	0.50	0.50	0.50	0.50	0.50	0.50	0.50	0.50	0.50	0.50	0.50
	5	TC	2.69	2.68	2.68	2.68	2.84	2.90	2.90	2.90	2.92	2.92	2.92	2.92	3.11	3.11	3.11	3.11
		S/T	0.67	0.73	0.78	0.84	0.56	0.62	0.67	0.72	0.51	0.56	0.62	0.67	0.39	0.44	0.49	0.54
		PI	0.50	0.50	0.50	0.50	0.50	0.50	0.50	0.50	0.51	0.51	0.51	0.51	0.50	0.50	0.50	0.50
	10	TC	2.67	2.66	2.66	2.66	2.83	2.89	2.89	2.89	2.91	2.91	2.91	2.91	3.11	3.11	3.11	3.11
		S/T	0.67	0.73	0.78	0.84	0.56	0.62	0.67	0.72	0.51	0.56	0.62	0.67	0.40	0.45	0.50	0.54
		PI	0.51	0.51	0.51	0.51	0.51	0.51	0.51	0.51	0.51	0.51	0.51	0.51	0.51	0.51	0.51	0.51
	15	TC	2.65	2.64	2.64	2.64	2.81	2.87	2.87	2.87	2.89	2.89	2.89	2.89	3.09	3.09	3.09	3.09
		S/T	0.68	0.74	0.79	0.85	0.57	0.62	0.68	0.73	0.52	0.57	0.63	0.68	0.40	0.45	0.50	0.55
		PI	0.52	0.52	0.52	0.52	0.52	0.52	0.52	0.52	0.53	0.53	0.53	0.53	0.52	0.52	0.52	0.52
	20	TC	2.62	2.61	2.61	2.61	2.78	2.78	2.78	2.78	2.87	2.87	2.87	2.87	3.07	3.07	3.07	3.07
		S/T	0.68	0.74	0.79	0.85	0.57	0.63	0.68	0.73	0.52	0.57	0.63	0.68	0.40	0.45	0.50	0.55
		PI	0.54	0.54	0.54	0.54	0.54	0.54	0.54	0.54	0.54	0.54	0.54	0.54	0.53	0.53	0.53	0.53
	25	TC	2.49	2.49	2.49	2.49	2.67	2.67	2.67	2.67	2.72	2.72	2.72	2.72	2.95	2.95	2.95	2.95
		S/T	0.68	0.74	0.80	0.86	0.57	0.63	0.68	0.74	0.52	0.57	0.63	0.69	0.40	0.45	0.50	0.55
		PI	0.60	0.60	0.60	0.60	0.59	0.59	0.59	0.59	0.59	0.59	0.59	0.59	0.60	0.60	0.60	0.60
	30	TC	2.38	2.38	2.38	2.38	2.52	2.52	2.52	2.52	2.61	2.61	2.61	2.61	2.81	2.81	2.81	2.81
		S/T	0.68	0.75	0.81	0.88	0.57	0.63	0.69	0.75	0.51	0.57	0.63	0.69	0.39	0.44	0.50	0.55
		PI	0.65	0.65	0.65	0.65	0.65	0.65	0.65	0.65	0.66	0.66	0.66	0.66	0.66	0.66	0.66	0.66
	35	TC	2.26	2.26	2.26	2.29	2.41	2.41	2.41	2.41	2.49	2.49	2.52	2.49	2.67	2.67	2.67	2.67
		S/T	0.69	0.75	0.82	0.89	0.57	0.63	0.70	0.76	0.51	0.57	0.64	0.70	0.38	0.44	0.50	0.56
		PI	0.71	0.71	0.71	0.71	0.72	0.72	0.72	0.72	0.72	0.72	0.72	0.72	0.72	0.72	0.72	0.72
	40	TC	2.13	2.13	2.13	2.15	2.26	2.26	2.26	2.26	2.34	2.34	2.36	2.34	2.51	2.51	2.51	2.51
		S/T	0.70	0.77	0.85	0.92	0.57	0.64	0.71	0.78	0.51	0.58	0.65	0.72	0.38	0.44	0.50	0.56
		PI	0.79	0.79	0.79	0.79	0.79	0.79	0.79	0.79	0.80	0.80	0.80	0.80	0.80	0.80	0.80	0.80
	46	TC	1.97	1.97	1.97	2.00	2.08	2.08	2.08	2.08	2.17	2.17	2.17	2.17	2.34	2.34	2.34	2.34
		S/T	0.70	0.78	0.86	0.93	0.57	0.65	0.72	0.79	0.51	0.58	0.65	0.72	0.37	0.44	0.50	0.57
		PI	0.88	0.88	0.88	0.88	0.88	0.88	0.88	0.88	0.89	0.89	0.89	0.89	0.89	0.89	0.89	0.89
	50	TC	1.86	1.86	1.86	1.88	1.97	1.97	1.97	1.97	2.03	2.03	2.03	2.03	2.20	2.20	2.20	2.20
		S/T	0.71	0.79	0.88	0.95	0.58	0.65	0.73	0.81	0.51	0.59	0.66	0.74	0.37	0.44	0.51	0.58
		PI	0.95	0.95	0.95	0.95	0.96	0.96	0.96	0.96	0.96	0.96	0.96	0.96	0.97	0.97	0.97	0.97

Specifications

309	-15	TC	2.83	2.83	2.83	2.86	2.95	2.95	2.95	2.95	3.03	3.03	3.03	3.03	3.23	3.23	3.23	3.23
		S/T	0.68	0.75	0.98	1.00	0.55	0.63	0.70	0.76	0.49	0.56	0.63	0.70	0.36	0.42	0.48	0.55
		PI	0.51	0.51	0.51	0.51	0.50	0.50	0.50	0.50	0.50	0.50	0.50	0.50	0.50	0.50	0.50	0.50
	-10	TC	2.81	2.81	2.81	2.84	2.94	2.94	2.94	2.94	3.01	3.01	3.01	3.01	3.22	3.22	3.22	3.22
		S/T	0.68	0.76	0.99	1.00	0.55	0.63	0.70	0.77	0.49	0.56	0.63	0.70	0.36	0.43	0.49	0.55
		PI	0.51	0.51	0.51	0.51	0.50	0.50	0.50	0.50	0.50	0.50	0.50	0.50	0.50	0.50	0.50	0.50
	-5	TC	2.79	2.79	2.79	2.82	2.92	2.92	2.92	2.92	3.00	3.00	3.00	3.00	3.21	3.21	3.21	3.21
		S/T	0.68	0.76	0.99	1.00	0.56	0.63	0.70	0.77	0.50	0.57	0.63	0.70	0.36	0.43	0.49	0.56
		PI	0.51	0.51	0.51	0.51	0.50	0.50	0.50	0.50	0.50	0.50	0.50	0.50	0.50	0.50	0.50	0.50
	0	TC	2.78	2.78	2.78	2.81	2.91	2.91	2.91	2.91	2.99	2.99	2.99	2.99	3.21	3.21	3.21	3.21
		S/T	0.69	0.76	1.00	1.00	0.56	0.64	0.71	0.77	0.50	0.57	0.64	0.71	0.36	0.43	0.49	0.56
		PI	0.51	0.51	0.51	0.51	0.50	0.50	0.50	0.50	0.50	0.50	0.50	0.50	0.51	0.51	0.51	0.51
	5	TC	2.76	2.76	2.76	2.79	2.90	2.90	2.90	2.90	2.98	2.98	2.98	2.98	3.20	3.20	3.20	3.20
		S/T	0.69	0.77	1.00	1.00	0.56	0.64	0.71	0.78	0.50	0.57	0.64	0.71	0.36	0.43	0.49	0.56
		PI	0.51	0.51	0.51	0.51	0.51	0.51	0.51	0.51	0.51	0.51	0.51	0.51	0.51	0.51	0.51	0.51
	10	TC	2.75	2.75	2.75	2.78	2.89	2.89	2.89	2.89	2.97	2.97	2.97	2.97	3.19	3.19	3.19	3.19
		S/T	0.69	0.77	1.00	1.00	0.56	0.64	0.71	0.78	0.50	0.57	0.64	0.71	0.37	0.44	0.50	0.56
		PI	0.52	0.52	0.52	0.52	0.51	0.51	0.51	0.51	0.51	0.51	0.51	0.51	0.52	0.52	0.52	0.52
15	TC	2.73	2.73	2.73	2.75	2.87	2.87	2.87	2.87	2.95	2.95	2.95	2.95	3.18	3.18	3.18	3.18	
	S/T	0.70	0.78	0.85	0.93	0.57	0.65	0.72	0.79	0.51	0.58	0.65	0.72	0.37	0.44	0.50	0.57	
	PI	0.53	0.53	0.53	0.53	0.52	0.52	0.52	0.52	0.53	0.53	0.53	0.53	0.53	0.53	0.53	0.53	
20	TC	2.70	2.70	2.70	2.72	2.84	2.84	2.84	2.84	2.92	2.92	2.92	2.92	3.15	3.15	3.15	3.15	
	S/T	0.70	0.78	0.85	0.93	0.57	0.65	0.72	0.79	0.51	0.58	0.65	0.72	0.37	0.44	0.50	0.57	
	PI	0.55	0.55	0.55	0.55	0.54	0.54	0.54	0.54	0.54	0.54	0.54	0.54	0.54	0.54	0.54	0.54	
25	TC	2.55	2.55	2.55	2.58	2.72	2.72	2.72	2.72	2.81	2.81	2.81	2.81	3.01	3.01	3.01	3.01	
	S/T	0.71	0.79	0.87	0.95	0.57	0.65	0.73	0.80	0.51	0.59	0.66	0.73	0.37	0.44	0.51	0.57	
	PI	0.60	0.60	0.60	0.60	0.60	0.60	0.60	0.60	0.60	0.60	0.60	0.60	0.60	0.60	0.60	0.60	
30	TC	2.44	2.44	2.47	2.49	2.58	2.58	2.58	2.58	2.67	2.67	2.67	2.67	2.87	2.87	2.87	2.87	
	S/T	0.72	0.80	0.88	0.96	0.58	0.66	0.74	0.82	0.51	0.59	0.67	0.75	0.36	0.44	0.51	0.58	
	PI	0.66	0.66	0.66	0.66	0.66	0.66	0.66	0.66	0.66	0.66	0.66	0.66	0.67	0.67	0.67	0.67	
35	TC	2.32	2.32	2.35	2.38	2.47	2.47	2.47	2.47	2.55	2.55	2.58	2.55	2.75	2.75	2.75	2.75	
	S/T	0.73	0.81	0.90	0.98	0.58	0.67	0.75	0.83	0.51	0.60	0.67	0.76	0.36	0.44	0.51	0.59	
	PI	0.72	0.72	0.72	0.72	0.73	0.73	0.73	0.73	0.73	0.73	0.73	0.73	0.73	0.73	0.73	0.73	
40	TC	2.17	2.17	2.20	2.23	2.31	2.31	2.31	2.31	2.40	2.40	2.42	2.40	2.59	2.59	2.59	2.59	
	S/T	0.75	0.85	0.94	1.00	0.59	0.68	0.78	0.87	0.52	0.61	0.70	0.79	0.35	0.44	0.52	0.60	
	PI	0.80	0.80	0.80	0.80	0.81	0.81	0.81	0.81	0.81	0.81	0.81	0.81	0.81	0.81	0.81	0.81	
46	TC	2.00	2.00	2.03	2.06	2.14	2.14	2.14	2.14	2.23	2.23	2.23	2.23	2.40	2.40	2.40	2.40	
	S/T	0.76	0.86	0.96	1.00	0.60	0.69	0.79	0.88	0.52	0.61	0.71	0.80	0.35	0.44	0.52	0.61	
	PI	0.89	0.89	0.89	0.89	0.90	0.90	0.90	0.90	0.90	0.90	0.90	0.90	0.91	0.91	0.91	0.91	
50	TC	1.89	1.89	1.91	1.94	2.03	2.03	2.03	2.06	2.09	2.09	2.09	2.09	2.26	2.26	2.26	2.26	
	S/T	0.77	0.88	0.98	1.00	0.60	0.70	0.81	0.90	0.53	0.62	0.72	0.82	0.35	0.44	0.53	0.91	
	PI	0.97	0.97	0.97	0.97	0.97	0.97	0.97	0.97	0.97	0.97	0.97	0.97	0.98	0.98	0.98	0.98	
416	-15	TC	2.89	2.89	2.92	2.95	3.01	3.01	3.01	3.01	3.09	3.09	3.09	3.09	3.29	3.29	3.29	3.29
		S/T	0.72	0.82	1.00	1.00	0.58	0.67	0.76	0.98	0.50	0.59	0.69	0.77	0.34	0.42	0.50	0.59
		PI	0.51	0.51	0.51	0.51	0.51	0.51	0.51	0.51	0.51	0.51	0.51	0.51	0.51	0.51	0.51	0.51
	-10	TC	2.87	2.87	2.90	2.93	2.99	2.99	2.99	2.99	3.07	3.07	3.07	3.07	3.28	3.28	3.28	3.28
		S/T	0.73	0.82	1.00	1.00	0.58	0.67	0.77	0.98	0.50	0.59	0.69	0.78	0.34	0.43	0.50	0.59
		PI	0.51	0.51	0.51	0.51	0.51	0.51	0.51	0.51	0.51	0.51	0.51	0.51	0.51	0.51	0.51	0.51
	-5	TC	2.85	2.85	2.88	2.91	2.98	2.98	2.98	2.98	3.06	3.06	3.06	3.06	3.27	3.27	3.27	3.27
		S/T	0.73	0.83	1.00	1.00	0.59	0.67	0.77	0.99	0.51	0.59	0.69	0.78	0.34	0.43	0.51	0.59
		PI	0.51	0.51	0.51	0.51	0.51	0.51	0.51	0.51	0.51	0.51	0.51	0.51	0.51	0.51	0.51	0.51
	0	TC	2.84	2.84	2.87	2.90	2.97	2.97	2.97	2.97	3.05	3.05	3.05	3.05	3.26	3.26	3.26	3.26
		S/T	0.74	0.83	1.00	1.00	0.59	0.68	0.77	0.99	0.51	0.60	0.70	0.78	0.34	0.43	0.51	0.60
		PI	0.51	0.51	0.51	0.51	0.51	0.51	0.51	0.51	0.51	0.51	0.51	0.51	0.51	0.51	0.51	0.51
	5	TC	2.82	2.82	2.85	2.88	2.96	2.96	2.96	2.96	3.04	3.04	3.04	3.04	3.26	3.26	3.26	3.26
		S/T	0.74	0.84	1.00	1.00	0.59	0.68	0.78	1.00	0.51	0.60	0.70	0.79	0.34	0.43	0.51	0.60
		PI	0.51	0.51	0.51	0.51	0.51	0.51	0.51	0.51	0.52	0.52	0.52	0.52	0.52	0.52	0.52	0.52
	10	TC	2.81	2.81	2.84	2.87	2.95	2.95	2.95	2.95	3.03	3.03	3.03	3.03	3.25	3.25	3.25	3.25
		S/T	0.74	0.84	1.00	1.00	0.59	0.68	0.78	1.00	0.51	0.60	0.70	0.79	0.35	0.44	0.51	0.60
		PI	0.52	0.52	0.52	0.52	0.52	0.52	0.52	0.52	0.52	0.52	0.52	0.52	0.53	0.53	0.53	0.53
15	TC	2.78	2.78	2.81	2.84	2.93	2.93	2.93	2.93	3.01	3.01	3.01	3.01	3.24	3.24	3.24	3.24	
	S/T	0.75	0.85	0.95	1.00	0.60	0.69	0.79	0.88	0.52	0.61	0.71	0.80	0.35	0.44	0.52	0.61	
	PI	0.53	0.53	0.53	0.53	0.53	0.53	0.53	0.53	0.53	0.53	0.53	0.53	0.54	0.54	0.54	0.54	
20	TC	2.75	2.75	2.78	2.81	2.90	2.90	2.90	2.90	2.98	2.98	2.98	2.98	3.21	3.21	3.21	3.21	
	S/T	0.75	0.85	0.95	1.00	0.60	0.69	0.79	0.88	0.52	0.61	0.71	0.80	0.35	0.44	0.52	0.61	
	PI	0.55	0.55	0.55	0.55	0.55	0.55	0.55	0.55	0.55	0.55	0.55	0.55	0.55	0.55	0.55	0.55	
25	TC	2.61	2.61	2.64	2.67	2.78	2.78	2.78	2.81	2.87	2.87	2.87	2.87	3.07	3.07	3.07	3.07	
	S/T	0.77	0.87	0.97	1.00	0.60	0.70	0.80	0.90	0.52	0.62	0.72	0.82	0.35	0.44	0.53	0.62	
	PI	0.61	0.61	0.61	0.61	0.61	0.61	0.61	0.61	0.61	0.61	0.61	0.61	0.61	0.61	0.61	0.61	
30	TC	2.49	2.52	2.55	2.58	2.64	2.64	2.64	2.67	2.72	2.72	2.72	2.72	2.95	2.95	2.95	2.95	
	S/T	0.78	0.89	0.99	1.00	0.61	0.71	0.82	0.92	0.53	0.63	0.73	0.83	0.35	0.44	0.53	0.63	
	PI	0.67	0.67	0.67	0.67	0.67	0.67	0.67	0.67	0.67	0.67	0.67	0.67	0.68	0.68	0.68	0.68	
35	TC	2.38	2.41	2.44	2.47	2.52	2.52	2.52	2.55	2.61	2.61	<b>2.64</b>	2.61	2.81	2.81	2.81	2.81	
	S/T	0.79	0.90	1.00	1.00	0.61	0.72	0.83	0.94	0.53	0.64	<b>0.74</b>	0.85	0.34	0.44	0.54	0.64	
	PI	0.73	0.73	0.73	0.73	0.74	0.74	0.74	0.74	0.74	0.74	<b>0.74</b>	0.74	0.74	0.74	0.74	0.74	
40	TC	2.23	2.26	2.29	2.31	2.37	2.37	2.38	2.41	2.44	2.44	2.46	2.46	2.64	2.64	2.64	2.64	
	S/T	0.82	0.95	1.00	1.00	0.63	0.75	0.87	0.99	0.54	0.66	0.77	0.89	0.34	0.44	0.55	0.90	
	PI	0.81	0.81	0.81	0.81	0.8												

		MM2-Y 35M / ML3-Y 35M+ IM2-XY 35M / IL3-XY 35M																	
INDOOR AIRFLOW (CMH)	OUTDOOR DB(C)	ID WB (C)	16.0				18.0				19.0				22.0				
		ID DB (C)	23.0	25.0	27.0	29.0	23.0	25.0	27.0	29.0	23.0	25.0	27.0	29.0	23.0	25.0	27.0	29.0	
395	-15	TC	3.71	3.72	3.72	3.75	3.90	3.96	3.96	3.96	4.00	4.00	4.00	4.00	4.25	4.25	4.25	4.25	
		S/T	0.68	0.74	0.82	0.89	0.55	0.62	0.69	0.75	0.49	0.56	0.63	0.70	0.36	0.42	0.48	0.55	
		PI	0.76	0.76	0.76	0.76	0.76	0.76	0.76	0.76	0.76	0.76	0.76	0.76	0.76	0.76	0.76	0.76	0.76
	-10	TC	3.68	3.70	3.70	3.73	3.87	3.93	3.93	3.93	3.98	3.98	3.98	3.98	4.23	4.23	4.23	4.23	
		S/T	0.68	0.75	0.82	0.89	0.55	0.62	0.69	0.76	0.49	0.56	0.63	0.70	0.36	0.43	0.49	0.55	
		PI	0.76	0.76	0.76	0.76	0.76	0.76	0.76	0.76	0.76	0.76	0.76	0.76	0.76	0.76	0.76	0.76	0.76
	-5	TC	3.66	3.67	3.67	3.70	3.86	3.92	3.92	3.92	3.96	3.96	3.96	3.96	4.22	4.22	4.22	4.22	
		S/T	0.68	0.75	0.83	0.90	0.56	0.63	0.69	0.76	0.50	0.57	0.63	0.70	0.36	0.43	0.49	0.56	
		PI	0.76	0.76	0.76	0.76	0.76	0.76	0.76	0.76	0.76	0.76	0.76	0.76	0.76	0.76	0.76	0.76	0.76
	0	TC	3.64	3.66	3.66	3.68	3.85	3.91	3.91	3.91	3.95	3.95	3.95	3.95	4.22	4.22	4.22	4.22	
		S/T	0.69	0.75	0.83	0.90	0.56	0.63	0.70	0.76	0.50	0.57	0.64	0.71	0.36	0.43	0.49	0.56	
		PI	0.76	0.76	0.76	0.76	0.76	0.76	0.76	0.76	0.76	0.76	0.76	0.76	0.76	0.76	0.76	0.76	0.76
	5	TC	3.62	3.64	3.64	3.67	3.83	3.89	3.89	3.89	3.94	3.94	3.94	3.94	4.21	4.21	4.21	4.21	
		S/T	0.69	0.76	0.84	0.91	0.56	0.63	0.70	0.77	0.50	0.57	0.64	0.71	0.36	0.43	0.49	0.56	
		PI	0.77	0.77	0.77	0.77	0.77	0.77	0.77	0.77	0.77	0.77	0.77	0.77	0.77	0.77	0.77	0.77	0.77
	10	TC	3.60	3.61	3.61	3.64	3.81	3.87	3.87	3.87	3.92	3.92	3.92	3.92	4.20	4.20	4.20	4.20	
		S/T	0.69	0.76	0.84	0.91	0.56	0.64	0.70	0.77	0.50	0.57	0.64	0.71	0.37	0.44	0.50	0.56	
		PI	0.78	0.78	0.78	0.78	0.78	0.78	0.78	0.78	0.78	0.78	0.78	0.78	0.78	0.78	0.78	0.78	0.78
	15	TC	3.57	3.59	3.59	3.61	3.79	3.85	3.85	3.85	3.90	3.90	3.90	3.90	4.19	4.19	4.19	4.19	
		S/T	0.70	0.77	0.85	0.92	0.57	0.64	0.71	0.78	0.51	0.58	0.65	0.72	0.37	0.44	0.50	0.57	
		PI	0.80	0.80	0.80	0.80	0.80	0.80	0.80	0.80	0.80	0.80	0.80	0.80	0.79	0.79	0.79	0.79	
	20	TC	3.53	3.54	3.54	3.57	3.75	3.75	3.75	3.75	3.86	3.86	3.86	3.86	4.15	4.15	4.15	4.15	
		S/T	0.70	0.77	0.85	0.92	0.57	0.64	0.71	0.78	0.51	0.58	0.65	0.72	0.37	0.44	0.50	0.57	
		PI	0.83	0.83	0.83	0.83	0.83	0.83	0.83	0.83	0.83	0.83	0.83	0.83	0.82	0.82	0.82	0.82	
	25	TC	3.37	3.37	3.37	3.40	3.57	3.57	3.57	3.57	3.69	3.69	3.69	3.69	3.98	3.98	3.98	3.98	
		S/T	0.71	0.78	0.86	0.94	0.57	0.65	0.72	0.80	0.51	0.58	0.66	0.73	0.37	0.44	0.50	0.57	
		PI	0.91	0.91	0.91	0.91	0.91	0.91	0.91	0.91	0.91	0.91	0.91	0.91	0.91	0.91	0.91	0.91	0.91
	30	TC	3.20	3.20	3.20	3.23	3.43	3.43	3.43	3.43	3.52	3.52	3.52	3.52	3.80	3.80	3.80	3.80	
		S/T	0.71	0.80	0.88	0.96	0.58	0.65	0.73	0.81	0.51	0.59	0.66	0.74	0.37	0.44	0.51	0.58	
		PI	1.00	1.00	1.00	1.00	1.00	1.00	1.00	1.00	1.00	1.00	1.00	1.00	1.00	1.00	1.00	1.00	1.00
	35	TC	3.05	3.05	3.08	3.11	3.26	3.26	3.26	3.26	3.34	3.34	3.34	3.34	3.60	3.60	3.60	3.60	
		S/T	0.72	0.81	0.89	0.97	0.58	0.66	0.74	0.82	0.51	0.59	0.67	0.75	0.36	0.44	0.51	0.58	
		PI	1.09	1.09	1.09	1.09	1.10	1.10	1.10	1.10	1.10	1.10	1.10	1.10	1.11	1.11	1.11	1.11	
	40	TC	2.89	2.89	2.92	2.95	3.09	3.09	3.09	3.09	3.18	3.18	3.21	3.18	3.43	3.43	3.43	3.43	
		S/T	0.74	0.84	0.93	1.00	0.59	0.68	0.77	0.86	0.52	0.60	0.69	0.78	0.36	0.44	0.52	0.60	
		PI	1.20	1.20	1.20	1.20	1.21	1.21	1.21	1.21	1.21	1.21	1.21	1.21	1.22	1.22	1.22	1.22	
	46	TC	2.67	2.67	2.70	2.73	2.87	2.87	2.87	2.87	2.96	2.96	2.96	2.96	3.19	3.19	3.19	3.19	
		S/T	0.75	0.85	0.95	1.00	0.59	0.69	0.78	0.87	0.52	0.61	0.70	0.79	0.35	0.44	0.52	0.60	
		PI	1.33	1.33	1.33	1.33	1.34	1.34	1.34	1.34	1.34	1.34	1.34	1.34	1.36	1.36	1.36	1.36	
	50	TC	2.53	2.53	2.55	2.58	2.70	2.70	2.70	2.73	2.79	2.79	2.79	2.79	3.02	3.02	3.02	3.02	
		S/T	0.76	0.87	0.97	1.00	0.60	0.70	0.80	0.89	0.52	0.62	0.72	0.81	0.35	0.44	0.53	0.61	
		PI	1.45	1.45	1.45	1.45	1.45	1.45	1.45	1.45	1.46	1.46	1.46	1.46	1.47	1.47	1.47	1.47	
	477	-15	TC	3.78	3.78	3.81	3.84	3.96	3.96	3.96	3.96	4.06	4.06	4.06	4.06	4.31	4.31	4.31	4.31
			S/T	0.70	0.78	0.98	1.00	0.56	0.65	0.72	0.81	0.50	0.58	0.66	0.73	0.35	0.42	0.49	0.57
			PI	0.78	0.78	0.78	0.78	0.77	0.77	0.77	0.77	0.77	0.77	0.77	0.77	0.77	0.77	0.77	0.77
		-10	TC	3.76	3.76	3.79	3.82	3.93	3.93	3.93	3.93	4.04	4.04	4.04	4.04	4.29	4.29	4.29	4.29
			S/T	0.71	0.79	0.99	1.00	0.56	0.65	0.73	0.82	0.50	0.58	0.66	0.74	0.35	0.43	0.49	0.57
			PI	0.77	0.77	0.77	0.77	0.77	0.77	0.77	0.77	0.77	0.77	0.77	0.77	0.77	0.77	0.77	0.77
-5		TC	3.73	3.73	3.76	3.79	3.92	3.92	3.92	3.92	4.02	4.02	4.02	4.02	4.28	4.28	4.28	4.28	
		S/T	0.71	0.79	0.99	1.00	0.57	0.65	0.73	0.82	0.51	0.59	0.66	0.74	0.35	0.43	0.50	0.58	
		PI	0.77	0.77	0.77	0.77	0.77	0.77	0.77	0.77	0.77	0.77	0.77	0.77	0.78	0.78	0.78	0.78	
0		TC	3.72	3.72	3.75	3.77	3.91	3.91	3.91	3.91	4.01	4.01	4.01	4.01	4.28	4.28	4.28	4.28	
		S/T	0.72	0.79	1.00	1.00	0.57	0.66	0.74	0.82	0.51	0.59	0.67	0.74	0.35	0.43	0.50	0.58	
		PI	0.78	0.78	0.78	0.78	0.77	0.77	0.77	0.77	0.77	0.77	0.77	0.77	0.78	0.78	0.78	0.78	
5		TC	3.70	3.70	3.73	3.76	3.89	3.89	3.89	3.89	4.00	4.00	4.00	4.00	4.27	4.27	4.27	4.27	
		S/T	0.72	0.80	1.00	1.00	0.57	0.66	0.74	0.83	0.51	0.59	0.67	0.75	0.35	0.43	0.50	0.58	
		PI	0.78	0.78	0.78	0.78	0.78	0.78	0.78	0.78	0.78	0.78	0.78	0.78	0.78	0.78	0.78	0.78	
10		TC	3.67	3.67	3.70	3.73	3.87	3.87	3.87	3.87	3.98	3.98	3.98	3.98	4.26	4.26	4.26	4.26	
		S/T	0.72	0.80	1.00	1.00	0.57	0.66	0.74	0.83	0.51	0.59	0.67	0.75	0.36	0.44	0.50	0.58	
		PI	0.80	0.80	0.80	0.80	0.79	0.79	0.79	0.79	0.79	0.79	0.79	0.79	0.79	0.79	0.79	0.79	
15		TC	3.64	3.64	3.67	3.70	3.85	3.85	3.85	3.85	3.96	3.96	3.96	3.96	4.25	4.25	4.25	4.25	
		S/T	0.73	0.81	0.90	0.99	0.58	0.67	0.75	0.84	0.52	0.60	0.68	0.76	0.36	0.44	0.51	0.59	
		PI	0.82	0.82	0.82	0.82	0.81	0.81	0.81	0.81	0.81	0.81	0.81	0.81	0.81	0.81	0.81	0.81	
20		TC	3.60	3.60	3.63	3.66	3.81	3.81	3.81	3.81	3.92	3.92	3.92	3.92	4.21	4.21	4.21	4.21	
		S/T	0.73	0.81	0.90	0.99	0.58	0.67	0.75	0.84	0.52	0.60	0.68	0.76	0.36	0.44	0.51	0.59	
		PI	0.85	0.85	0.85	0.85	0.84	0.84	0.84	0.84	0.84	0.84	0.84	0.84	0.84	0.84	0.84	0.84	
25		TC	3.43	3.43	3.46	3.49	3.63	3.63	3.63	3.63	3.75	3.75	3.75	3.75	4.04	4.04	4.04		

584	-15	TC	3.84	3.84	3.87	3.90	4.02	4.02	4.02	4.05	4.12	4.12	4.12	4.12	4.40	4.40	4.40	4.40
		S/T	0.74	0.85	1.00	1.00	0.58	0.68	0.78	0.98	0.51	0.60	0.70	0.79	0.34	0.42	0.51	0.60
		PI	0.79	0.79	0.79	0.79	0.79	0.79	0.79	0.79	0.79	0.79	0.79	0.79	0.79	0.78	0.78	0.78
	-10	TC	3.82	3.82	3.85	3.88	3.99	3.99	3.99	4.02	4.10	4.10	4.10	4.10	4.38	4.38	4.38	4.38
		S/T	0.75	0.85	1.00	1.00	0.58	0.68	0.79	0.98	0.51	0.60	0.70	0.80	0.34	0.43	0.51	0.60
		PI	0.78	0.78	0.78	0.78	0.79	0.79	0.79	0.79	0.79	0.79	0.79	0.79	0.79	0.78	0.78	0.78
	-5	TC	3.79	3.79	3.82	3.85	3.98	3.98	3.98	4.01	4.08	4.08	4.08	4.08	4.37	4.37	4.37	4.37
		S/T	0.75	0.86	1.00	1.00	0.59	0.68	0.79	0.99	0.52	0.60	0.70	0.80	0.34	0.43	0.52	0.60
		PI	0.78	0.78	0.78	0.78	0.79	0.79	0.79	0.79	0.79	0.79	0.79	0.79	0.79	0.78	0.78	0.78
	0	TC	3.77	3.77	3.80	3.83	3.96	3.96	3.96	3.99	4.07	4.07	4.07	4.07	4.37	4.37	4.37	4.37
		S/T	0.75	0.86	1.00	1.00	0.59	0.69	0.79	0.99	0.52	0.61	0.71	0.80	0.34	0.43	0.52	0.61
		PI	0.79	0.79	0.79	0.79	0.79	0.79	0.79	0.79	0.79	0.79	0.79	0.79	0.79	0.79	0.79	0.79
	5	TC	3.76	3.76	3.79	3.82	3.95	3.95	3.95	3.98	4.06	4.06	4.06	4.06	4.36	4.36	4.36	4.36
		S/T	0.76	0.87	1.00	1.00	0.59	0.69	0.80	1.00	0.52	0.61	0.71	0.81	0.34	0.43	0.52	0.61
		PI	0.79	0.79	0.79	0.79	0.80	0.80	0.80	0.80	0.80	0.80	0.80	0.80	0.79	0.79	0.79	0.79
	10	TC	3.73	3.73	3.76	3.79	3.93	3.93	3.93	3.96	4.04	4.04	4.04	4.04	4.35	4.35	4.35	4.35
		S/T	0.76	0.87	1.00	1.00	0.59	0.69	0.80	1.00	0.52	0.61	0.71	0.81	0.35	0.44	0.52	0.61
		PI	0.81	0.81	0.81	0.81	0.81	0.81	0.81	0.81	0.81	0.81	0.81	0.81	0.80	0.80	0.80	0.80
15	TC	3.70	3.70	3.73	3.76	3.90	3.90	3.90	3.93	4.02	4.02	4.02	4.02	4.33	4.33	4.33	4.33	
	S/T	0.77	0.88	0.98	1.00	0.60	0.70	0.81	0.90	0.53	0.62	0.72	0.82	0.35	0.44	0.53	0.62	
	PI	0.83	0.83	0.83	0.83	0.83	0.83	0.83	0.83	0.83	0.83	0.83	0.83	0.82	0.82	0.82	0.82	
20	TC	3.66	3.66	3.69	3.72	3.86	3.86	3.86	3.89	3.98	3.98	3.98	3.98	4.30	4.30	4.30	4.30	
	S/T	0.77	0.88	0.98	1.00	0.60	0.70	0.81	0.90	0.53	0.62	0.72	0.82	0.35	0.44	0.53	0.62	
	PI	0.86	0.86	0.86	0.86	0.86	0.86	0.86	0.86	0.86	0.86	0.86	0.86	0.85	0.85	0.85	0.85	
25	TC	3.49	3.52	3.55	3.57	3.69	3.69	3.69	3.72	3.81	3.81	3.81	3.81	4.09	4.09	4.09	4.09	
	S/T	0.78	0.89	1.00	1.00	0.61	0.72	0.82	0.93	0.53	0.63	0.74	0.84	0.34	0.44	0.54	0.63	
	PI	0.94	0.94	0.94	0.94	0.94	0.94	0.94	0.94	0.94	0.94	0.94	0.94	0.94	0.94	0.94	0.94	
30	TC	3.32	3.34	3.37	3.40	3.55	3.55	3.55	3.57	3.63	3.63	3.63	3.63	3.92	3.92	3.92	3.92	
	S/T	0.80	0.91	1.00	1.00	0.61	0.73	0.84	0.94	0.53	0.64	0.75	0.86	0.34	0.44	0.54	0.64	
	PI	1.03	1.03	1.03	1.03	1.04	1.04	1.04	1.04	1.04	1.04	1.04	1.04	1.04	1.04	1.04	1.04	
35	TC	3.14	3.17	3.20	3.23	3.37	3.37	3.37	3.40	3.46	3.46	<b>3.52</b>	3.46	3.75	3.75	3.75	3.75	
	S/T	0.81	0.93	1.00	1.00	0.62	0.74	0.86	0.97	0.54	0.65	<b>0.76</b>	0.88	0.34	0.44	0.55	0.65	
	PI	1.13	1.13	1.13	1.13	1.14	1.14	1.14	1.14	1.14	1.14	<b>1.14</b>	1.14	1.15	1.15	1.15	1.15	
40	TC	2.92	2.95	2.98	3.01	3.14	3.14	3.15	3.18	3.22	3.22	3.25	3.24	3.50	3.50	3.50	3.50	
	S/T	0.84	0.97	1.00	1.00	0.64	0.77	0.89	1.00	0.55	0.67	0.79	0.91	0.33	0.45	0.56	0.90	
	PI	1.25	1.25	1.25	1.25	1.26	1.26	1.26	1.26	1.26	1.26	1.26	1.26	1.27	1.27	1.27	1.27	
46	TC	2.71	2.73	2.76	2.79	2.90	2.90	2.93	2.96	2.99	2.99	2.99	3.02	3.25	3.25	3.25	3.25	
	S/T	0.86	1.00	1.00	1.00	0.65	0.78	0.91	1.00	0.55	0.68	0.81	0.94	0.33	0.45	0.57	0.92	
	PI	1.39	1.39	1.39	1.39	1.40	1.40	1.40	1.40	1.40	1.40	1.40	1.40	1.42	1.42	1.42	1.42	
50	TC	2.56	2.59	2.62	2.65	2.73	2.73	2.76	2.79	2.82	2.82	2.82	2.85	3.05	3.05	3.05	3.05	
	S/T	0.88	1.00	1.00	1.00	0.66	0.80	0.94	1.00	0.56	0.70	0.84	0.97	0.33	0.45	0.58	0.97	
	PI	1.51	1.51	1.51	1.51	1.52	1.52	1.52	1.52	1.52	1.52	1.52	1.52	1.53	1.53	1.53	1.53	

TC:Total Cooling Capacity (kW)

S/T:Sensible Cooling Capacity Ratio

PI:Power Input(kW)

**Note: The table shows the case where the operation frequency of a compressor is fixed.**

		MM2-Y 53M / ML3-Y 53M + IM2-XY 53M / IL3-XY 53M																	
INDOOR AIRFLOW (CMH)	OUTDOOR DB(C)	ID WB (C) ID DB (C)	16.0				18.0				19.0				22.0				
			23.0	25.0	27.0	29.0	23.0	25.0	27.0	29.0	23.0	25.0	27.0	29.0	23.0	25.0	27.0	29.0	
420	-15	TC	5.50	5.50	5.50	5.50	5.78	5.90	5.90	5.90	5.93	5.93	5.93	5.93	6.28	6.28	6.28	6.28	
		S/T	0.65	0.70	0.75	0.80	0.55	0.60	0.65	0.70	0.51	0.55	0.60	0.65	0.40	0.44	0.48	0.53	
		PI	1.03	1.03	1.03	1.03	1.03	1.03	1.03	1.03	1.03	1.03	1.03	1.03	1.03	1.03	1.03	1.03	
	-10	TC	5.46	5.47	5.47	5.47	5.75	5.87	5.87	5.87	5.90	5.90	5.90	5.90	6.25	6.25	6.25	6.25	
		S/T	0.65	0.71	0.76	0.81	0.55	0.60	0.65	0.70	0.51	0.55	0.60	0.65	0.40	0.45	0.49	0.53	
		PI	1.03	1.02	1.02	1.03	1.03	1.03	1.03	1.03	1.03	1.03	1.03	1.03	1.03	1.03	1.03	1.03	
	-5	TC	5.43	5.43	5.43	5.43	5.73	5.85	5.85	5.85	5.88	5.88	5.88	5.88	6.24	6.24	6.24	6.24	
		S/T	0.65	0.71	0.76	0.81	0.56	0.61	0.65	0.70	0.52	0.56	0.60	0.65	0.40	0.45	0.49	0.54	
		PI	1.03	1.02	1.02	1.03	1.03	1.03	1.03	1.03	1.03	1.03	1.03	1.03	1.03	1.03	1.03	1.03	
	0	TC	5.40	5.41	5.41	5.41	5.71	5.83	5.83	5.83	5.87	5.87	5.87	5.87	6.23	6.23	6.23	6.23	
		S/T	0.66	0.72	0.76	0.81	0.56	0.61	0.66	0.71	0.52	0.56	0.61	0.66	0.40	0.45	0.49	0.54	
		PI	1.03	1.03	1.03	1.03	1.03	1.03	1.03	1.03	1.03	1.03	1.03	1.03	1.03	1.03	1.03	1.03	
	5	TC	5.38	5.38	5.38	5.38	5.68	5.80	5.80	5.80	5.85	5.85	5.85	5.85	6.23	6.23	6.23	6.23	
		S/T	0.66	0.72	0.77	0.82	0.56	0.61	0.66	0.71	0.52	0.56	0.61	0.66	0.40	0.45	0.49	0.54	
		PI	1.04	1.04	1.04	1.04	1.04	1.04	1.04	1.04	1.04	1.04	1.04	1.04	1.04	1.04	1.04	1.04	
	10	TC	5.34	5.35	5.35	5.35	5.66	5.78	5.78	5.78	5.82	5.82	5.82	5.82	6.21	6.21	6.21	6.21	
		S/T	0.66	0.72	0.77	0.82	0.56	0.62	0.66	0.71	0.52	0.56	0.61	0.66	0.41	0.46	0.50	0.54	
		PI	1.06	1.05	1.05	1.06	1.06	1.06	1.06	1.06	1.06	1.06	1.06	1.06	1.05	1.05	1.05	1.05	
	15	TC	5.30	5.30	5.30	5.30	5.62	5.74	5.74	5.74	5.79	5.79	5.79	5.79	6.19	6.19	6.19	6.19	
		S/T	0.67	0.73	0.78	0.83	0.57	0.62	0.67	0.72	0.53	0.57	0.62	0.67	0.41	0.46	0.50	0.55	
		PI	1.08	1.08	1.08	1.08	1.08	1.08	1.08	1.08	1.08	1.08	1.08	1.08	1.08	1.08	1.08	1.08	
	20	TC	5.24	5.24	5.24	5.24	5.56	5.56	5.56	5.56	5.73	5.73	5.73	5.73	6.13	6.13	6.13	6.13	
		S/T	0.67	0.73	0.78	0.83	0.57	0.62	0.67	0.72	0.53	0.57	0.62	0.67	0.41	0.46	0.50	0.55	
		PI	1.12	1.12	1.12	1.12	1.12	1.12	1.12	1.12	1.12	1.12	1.12	1.12	1.11	1.11	1.11	1.11	
	25	TC	4.99	4.99	4.99	4.99	5.30	5.30	5.30	5.30	5.47	5.47	5.47	5.47	5.87	5.87	5.87	5.87	
		S/T	0.67	0.73	0.79	0.84	0.57	0.62	0.68	0.73	0.52	0.57	0.62	0.68	0.41	0.45	0.50	0.55	
		PI	1.24	1.24	1.24	1.24	1.24	1.24	1.24	1.24	1.24	1.24	1.24	1.24	1.24	1.24	1.24	1.24	
	30	TC	4.76	4.76	4.76	4.76	5.07	5.07	5.07	5.07	5.22	5.22	5.22	5.22	5.62	5.62	5.62	5.62	
		S/T	0.68	0.74	0.79	0.85	0.57	0.62	0.68	0.74	0.52	0.57	0.63	0.68	0.40	0.45	0.50	0.55	
		PI	1.35	1.35	1.35	1.35	1.35	1.35	1.35	1.35	1.35	1.35	1.35	1.35	1.36	1.36	1.36	1.36	
	35	TC	4.53	4.53	4.53	4.53	4.81	4.81	4.81	4.81	4.96	4.96	4.96	4.96	5.36	5.36	5.36	5.36	
		S/T	0.68	0.74	0.80	0.87	0.57	0.63	0.68	0.74	0.52	0.57	0.63	0.69	0.40	0.45	0.50	0.55	
		PI	1.48	1.48	1.48	1.48	1.48	1.48	1.48	1.48	1.49	1.49	1.49	1.49	1.50	1.50	1.50	1.50	
	40	TC	4.28	4.28	4.28	4.29	4.55	4.55	4.55	4.55	4.70	4.70	4.70	4.70	5.07	5.07	5.07	5.07	
		S/T	0.69	0.76	0.82	0.89	0.57	0.63	0.70	0.76	0.51	0.57	0.64	0.70	0.39	0.44	0.50	0.56	
		PI	1.64	1.64	1.64	1.64	1.64	1.64	1.64	1.64	1.65	1.65	1.65	1.65	1.66	1.66	1.66	1.66	
	46	TC	3.97	3.97	3.97	4.00	4.22	4.22	4.22	4.22	4.37	4.37	4.37	4.37	4.71	4.71	4.71	4.71	
		S/T	0.69	0.76	0.83	0.90	0.57	0.64	0.70	0.77	0.51	0.58	0.64	0.71	0.38	0.44	0.50	0.56	
		PI	1.82	1.82	1.82	1.82	1.83	1.83	1.83	1.83	1.84	1.84	1.84	1.84	1.85	1.85	1.85	1.85	
	50	TC	3.71	3.71	3.71	3.74	3.97	3.97	3.97	3.97	4.11	4.11	4.11	4.11	4.45	4.45	4.45	4.45	
		S/T	0.70	0.78	0.85	0.93	0.57	0.64	0.71	0.78	0.51	0.58	0.65	0.72	0.38	0.44	0.50	0.56	
		PI	1.98	1.98	1.98	1.98	1.98	1.98	1.98	1.98	1.99	1.99	1.99	1.99	2.01	2.01	2.01	2.01	
	500	-15	TC	5.62	5.62	5.62	5.62	5.90	5.90	5.90	5.90	6.06	6.06	6.06	6.06	6.43	6.43	6.43	6.43
			S/T	0.66	0.71	0.98	1.00	0.55	0.61	0.67	0.71	0.50	0.55	0.61	0.67	0.38	0.43	0.48	0.53
			PI	1.06	1.06	1.06	1.06	1.05	1.05	1.05	1.05	1.05	1.05	1.05	1.05	1.04	1.04	1.04	1.04
		-10	TC	5.59	5.59	5.59	5.59	5.87	5.87	5.87	5.87	6.03	6.03	6.03	6.03	6.40	6.40	6.40	6.40
			S/T	0.66	0.72	0.99	1.00	0.55	0.61	0.67	0.72	0.50	0.55	0.61	0.67	0.38	0.44	0.49	0.53
			PI	1.05	1.05	1.05	1.05	1.05	1.05	1.05	1.05	1.05	1.05	1.05	1.05	1.05	1.05	1.05	1.05
-5		TC	5.56	5.56	5.56	5.56	5.85	5.85	5.85	5.85	6.00	6.00	6.00	6.00	6.39	6.39	6.39	6.39	
		S/T	0.66	0.72	0.99	1.00	0.56	0.61	0.67	0.72	0.51	0.56	0.61	0.67	0.38	0.44	0.49	0.54	
		PI	1.05	1.05	1.05	1.05	1.05	1.05	1.05	1.05	1.05	1.05	1.05	1.05	1.05	1.05	1.05	1.05	
0		TC	5.53	5.53	5.53	5.53	5.83	5.83	5.83	5.83	5.99	5.99	5.99	5.99	6.38	6.38	6.38	6.38	
		S/T	0.67	0.73	1.00	1.00	0.56	0.62	0.68	0.73	0.51	0.56	0.62	0.68	0.38	0.44	0.49	0.54	
		PI	1.06	1.06	1.06	1.06	1.05	1.05	1.05	1.05	1.05	1.05	1.05	1.05	1.05	1.05	1.05	1.05	
5		TC	5.50	5.50	5.50	5.50	5.80	5.80	5.80	5.80	5.97	5.97	5.97	5.97	6.38	6.38	6.38	6.38	
		S/T	0.67	0.73	1.00	1.00	0.56	0.62	0.68	0.73	0.51	0.56	0.62	0.68	0.38	0.44	0.49	0.54	
		PI	1.06	1.06	1.06	1.06	1.06	1.06	1.06	1.06	1.06	1.06	1.06	1.06	1.06	1.06	1.06	1.06	
10		TC	5.47	5.47	5.47	5.47	5.78	5.78	5.78	5.78	5.94	5.94	5.94	5.94	6.36	6.36	6.36	6.36	
		S/T	0.67	0.73	1.00	1.00	0.56	0.62	0.68	0.73	0.51	0.56	0.62	0.68	0.39	0.45	0.50	0.54	
		PI	1.08	1.08	1.08	1.08	1.08	1.08	1.08	1.08	1.08	1.08	1.08	1.08	1.07	1.07	1.07	1.07	
15		TC	5.42	5.42	5.42	5.42	5.74	5.74	5.74	5.74	5.91	5.91	5.91	5.91	6.33	6.33	6.33	6.33	
		S/T	0.68	0.74	0.80	0.87	0.57	0.63	0.69	0.74	0.52	0.57	0.63	0.69	0.39	0.45	0.50	0.55	
		PI	1.11	1.11	1.11	1.11	1.10	1.10	1.10	1.10	1.10	1.10	1.10	1.10	1.10	1.10	1.10	1.10	
20		TC	5.36	5.36	5.36	5.36	5.68	5.68	5.68	5.68	5.85	5.85	5.85	5.85	6.28	6.28	6.28	6.28	
		S/T	0.68	0.74	0.80	0.87	0.57	0.63	0.69	0.74	0.52	0.57	0.63	0.69	0.39	0.45	0.50	0.55	
		PI	1.15	1.15	1.15	1.15	1.14	1.14	1.14	1.14	1.14	1.14	1.14	1.14	1.13	1.13	1.13	1.13	
25		TC	5.10	5.10	5.10	5.10	5.42	5.42	5.42	5.42	5.59	5.59	5.59	5.59	6.02	6.02	6.02	6.02	
		S/T	0.68	0.75	0.81	0.88	0.57	0.63	0.69	0.75	0.51	0.57	0.63	0.69	0.39	0.44	0.50	0.55	
		PI	1.27	1.27	1.27	1.27	1.26	1.26	1.26	1.26	1.26	1.26	1.26	1.26	1.27	1.27	1.27	1.27	
30		TC	4.87	4.87	4.87	4.93	5.19	5.19	5.19	5.19	5.33	5.33	5.33	5.33	5.76	5.76	5.76	5.76	
		S/T	0.69	0.76	0.83	0.89	0.57	0.63	0.70	0.76	0.51	0.58	0.64	0.70	0.38	0.44	0.50	0.56	
		PI	1.38	1.38	1.38	1.38	1.38	1.38	1.38	1.38	1.38	1.38	1.38	1.38	1.39	1.39	1.39	1.39	
35		TC	4.62	4.62	4.62	4.67	4.93	4.93	4.93	4.93	5.07	5.07	5.16	5.07	5.48	5.48	5.48	5.48	
		S/T	0.69	0.77	0.84	0.91	0.57	0.64	0.71	0.77	0.51	0.							

730	-15	TC	5.74	5.74	5.80	5.86	6.05	6.05	6.05	6.05	6.20	6.20	6.20	6.20	6.57	6.57	6.57	6.57
		S/T	0.70	0.79	1.00	1.00	0.56	0.65	0.72	0.98	0.50	0.58	0.66	0.73	0.35	0.42	0.49	0.57
		PI	1.08	1.08	1.08	1.08	1.07	1.07	1.07	1.07	1.07	1.07	1.07	1.07	1.07	1.07	1.07	1.07
	-10	TC	5.71	5.71	5.77	5.83	6.02	6.02	6.02	6.02	6.17	6.17	6.17	6.17	6.55	6.55	6.55	6.55
		S/T	0.71	0.80	1.00	1.00	0.56	0.65	0.73	0.98	0.50	0.58	0.66	0.74	0.35	0.43	0.49	0.57
		PI	1.07	1.07	1.07	1.07	1.07	1.07	1.07	1.07	1.07	1.07	1.07	1.07	1.07	1.07	1.07	1.07
	-5	TC	5.67	5.67	5.73	5.79	6.00	6.00	6.00	6.00	6.15	6.15	6.15	6.15	6.53	6.53	6.53	6.53
		S/T	0.71	0.80	1.00	1.00	0.57	0.65	0.73	0.99	0.51	0.59	0.66	0.74	0.35	0.43	0.50	0.58
		PI	1.07	1.07	1.07	1.07	1.06	1.06	1.06	1.06	1.07	1.07	1.07	1.07	1.07	1.07	1.07	1.07
	0	TC	5.65	5.65	5.71	5.76	5.97	5.97	5.97	5.97	6.13	6.13	6.13	6.13	6.53	6.53	6.53	6.53
		S/T	0.72	0.80	1.00	1.00	0.57	0.66	0.74	0.99	0.51	0.59	0.67	0.74	0.35	0.43	0.50	0.58
		PI	1.07	1.07	1.07	1.07	1.07	1.07	1.07	1.07	1.07	1.07	1.07	1.07	1.08	1.08	1.08	1.08
	5	TC	5.62	5.62	5.68	5.74	5.95	5.95	5.95	5.95	6.11	6.11	6.11	6.11	6.52	6.52	6.52	6.52
		S/T	0.72	0.81	1.00	1.00	0.57	0.66	0.74	1.00	0.51	0.59	0.67	0.75	0.35	0.43	0.50	0.58
		PI	1.08	1.08	1.08	1.08	1.08	1.08	1.08	1.08	1.08	1.08	1.08	1.08	1.09	1.09	1.09	1.09
	10	TC	5.58	5.58	5.64	5.70	5.92	5.92	5.92	5.92	6.09	6.09	6.09	6.09	6.51	6.51	6.51	6.51
		S/T	0.72	0.81	1.00	1.00	0.57	0.66	0.74	1.00	0.51	0.59	0.67	0.75	0.36	0.44	0.50	0.58
		PI	1.10	1.10	1.10	1.10	1.09	1.09	1.09	1.09	1.10	1.10	1.10	1.10	1.10	1.10	1.10	1.10
15	TC	5.54	5.54	5.60	5.65	5.88	5.88	5.88	5.88	6.05	6.05	6.05	6.05	6.48	6.48	6.48	6.48	
	S/T	0.73	0.82	0.90	0.98	0.58	0.67	0.75	0.83	0.52	0.60	0.68	0.76	0.36	0.44	0.51	0.59	
	PI	1.13	1.13	1.13	1.13	1.12	1.12	1.12	1.12	1.12	1.12	1.12	1.12	1.12	1.12	1.12	1.12	1.12
20	TC	5.48	5.48	5.53	5.59	5.82	5.82	5.82	5.82	5.99	5.99	5.99	5.99	6.42	6.42	6.42	6.42	
	S/T	0.73	0.82	0.90	0.98	0.58	0.67	0.75	0.83	0.52	0.60	0.68	0.76	0.36	0.44	0.51	0.59	
	PI	1.17	1.17	1.17	1.17	1.16	1.16	1.16	1.16	1.16	1.16	1.16	1.16	1.16	1.16	1.16	1.16	1.16
25	TC	5.22	5.22	5.28	5.33	5.56	5.56	5.56	5.56	5.73	5.73	5.73	5.73	6.16	6.16	6.16	6.16	
	S/T	0.74	0.83	0.92	1.00	0.59	0.67	0.76	0.85	0.52	0.60	0.69	0.77	0.36	0.44	0.52	0.59	
	PI	1.29	1.29	1.29	1.29	1.29	1.29	1.29	1.29	1.29	1.29	1.29	1.29	1.29	1.29	1.29	1.29	1.29
30	TC	4.99	4.99	5.05	5.10	5.30	5.30	5.30	5.30	5.45	5.45	5.45	5.45	5.88	5.88	5.88	5.88	
	S/T	0.75	0.84	0.94	1.00	0.59	0.68	0.78	0.87	0.52	0.61	0.70	0.79	0.35	0.44	0.52	0.60	
	PI	1.40	1.40	1.40	1.40	1.41	1.41	1.41	1.41	1.41	1.41	1.41	1.41	1.42	1.42	1.42	1.42	
35	TC	4.73	4.73	4.79	4.85	5.05	5.05	5.05	5.10	5.19	5.19	<b>5.28</b>	5.19	5.59	5.59	5.59	5.59	
	S/T	0.76	0.86	0.96	1.00	0.60	0.69	0.79	0.88	0.52	0.62	<b>0.71</b>	0.80	0.35	0.44	0.52	0.61	
	PI	1.54	1.54	1.54	1.54	1.54	1.54	1.54	1.54	1.55	1.55	<b>1.55</b>	1.55	1.56	1.56	1.56	1.56	
40	TC	4.44	4.45	4.50	4.54	4.74	4.74	4.74	4.80	4.89	4.89	4.89	4.89	5.27	5.27	5.27	5.27	
	S/T	0.78	0.89	1.00	1.00	0.61	0.72	0.82	0.92	0.53	0.63	0.74	0.84	0.34	0.44	0.53	0.60	
	PI	1.70	1.70	1.70	1.70	1.70	1.70	1.70	1.70	1.71	1.71	1.71	1.71	1.72	1.72	1.72	1.72	
46	TC	4.11	4.14	4.17	4.20	4.40	4.40	4.40	4.46	4.54	4.54	4.54	4.54	4.91	4.91	4.91	4.91	
	S/T	0.80	0.91	1.00	1.00	0.61	0.73	0.84	0.94	0.53	0.64	0.75	0.85	0.34	0.44	0.54	0.62	
	PI	1.89	1.89	1.89	1.89	1.89	1.89	1.89	1.89	1.90	1.90	1.90	1.90	1.92	1.92	1.92	1.92	
50	TC	3.86	3.89	3.91	3.94	4.11	4.11	4.11	4.14	4.26	4.26	4.26	4.26	4.63	4.63	4.63	4.63	
	S/T	0.82	0.94	1.00	1.00	0.63	0.74	0.86	0.98	0.54	0.65	0.77	0.88	0.34	0.44	0.55	0.63	
	PI	2.05	2.05	2.05	2.05	2.05	2.05	2.05	2.05	2.06	2.06	2.06	2.06	2.08	2.08	2.08	2.08	

TC:Total Cooling Capacity (kW)

S/T:Sensible Cooling Capacity Ratio

PI:Power Input(kW)

**Note: The table shows the case where the operation frequency of a compressor is fixed.**

		MM2-Y 70M / ML3-Y 70M + IM2-XY 70M / IL3-XY 70M																
INDOOR AIRFLOW (CMH)	OUTDOOR DB(C)	ID WB (C)	16.0				18.0				19.0				22.0			
			ID DB (C)	23.0	25.0	27.0	29.0	23.0	25.0	27.0	29.0	23.0	25.0	27.0	29.0	23.0	25.0	27.0
640	-15	TC	7.35	7.34	7.34	7.34	7.73	7.88	7.88	7.88	7.93	7.93	7.93	7.93	8.40	8.40	8.40	8.40
		S/T	0.66	0.71	0.77	0.83	0.55	0.60	0.66	0.71	0.50	0.55	0.61	0.66	0.39	0.43	0.48	0.53
		PI	1.55	1.55	1.55	1.55	1.55	1.55	1.55	1.55	1.55	1.55	1.55	1.55	1.55	1.55	1.55	1.55
	-10	TC	7.31	7.30	7.30	7.30	7.69	7.84	7.84	7.84	7.89	7.89	7.89	7.89	8.37	8.37	8.37	8.37
		S/T	0.66	0.72	0.78	0.83	0.55	0.61	0.66	0.72	0.50	0.55	0.61	0.66	0.39	0.44	0.49	0.53
		PI	1.55	1.54	1.54	1.55	1.55	1.55	1.55	1.55	1.54	1.54	1.54	1.54	1.55	1.55	1.55	1.55
	-5	TC	7.26	7.26	7.26	7.26	7.66	7.81	7.81	7.81	7.86	7.86	7.86	7.86	8.35	8.35	8.35	8.35
		S/T	0.66	0.72	0.78	0.84	0.56	0.61	0.66	0.72	0.51	0.56	0.61	0.66	0.39	0.44	0.49	0.54
		PI	1.54	1.54	1.54	1.54	1.55	1.55	1.55	1.55	1.54	1.54	1.54	1.54	1.55	1.55	1.55	1.55
	0	TC	7.23	7.22	7.22	7.22	7.63	7.78	7.78	7.78	7.84	7.84	7.84	7.84	8.34	8.34	8.34	8.34
		S/T	0.67	0.73	0.78	0.84	0.56	0.61	0.67	0.73	0.51	0.56	0.62	0.67	0.39	0.44	0.49	0.54
		PI	1.55	1.55	1.55	1.55	1.55	1.55	1.55	1.55	1.55	1.55	1.55	1.55	1.56	1.56	1.56	1.56
	5	TC	7.19	7.18	7.18	7.18	7.60	7.75	7.75	7.75	7.82	7.82	7.82	7.82	8.34	8.34	8.34	8.34
		S/T	0.67	0.73	0.79	0.85	0.56	0.62	0.67	0.73	0.51	0.56	0.62	0.67	0.39	0.44	0.49	0.54
		PI	1.56	1.56	1.56	1.56	1.57	1.57	1.57	1.57	1.56	1.56	1.56	1.56	1.57	1.57	1.57	1.57
	10	TC	7.15	7.14	7.14	7.14	7.56	7.71	7.71	7.71	7.79	7.79	7.79	7.79	8.31	8.31	8.31	8.31
		S/T	0.67	0.73	0.79	0.85	0.56	0.62	0.67	0.73	0.51	0.56	0.62	0.67	0.40	0.45	0.50	0.54
		PI	1.59	1.59	1.59	1.59	1.59	1.59	1.59	1.59	1.58	1.58	1.58	1.58	1.59	1.59	1.59	1.59
	15	TC	7.09	7.08	7.08	7.08	7.51	7.66	7.66	7.66	7.74	7.74	7.74	7.74	8.28	8.28	8.28	8.28
		S/T	0.68	0.74	0.80	0.86	0.57	0.62	0.68	0.74	0.52	0.57	0.63	0.68	0.40	0.45	0.50	0.55
		PI	1.63	1.63	1.63	1.63	1.63	1.63	1.63	1.63	1.62	1.62	1.62	1.62	1.62	1.62	1.62	1.62
	20	TC	7.01	7.00	7.00	7.00	7.43	7.43	7.43	7.43	7.66	7.66	7.66	7.66	8.21	8.21	8.21	8.21
		S/T	0.68	0.74	0.80	0.86	0.57	0.63	0.68	0.74	0.52	0.57	0.63	0.68	0.40	0.45	0.50	0.55
		PI	1.69	1.68	1.68	1.69	1.68	1.68	1.68	1.68	1.67	1.67	1.67	1.67	1.67	1.67	1.67	1.67
	25	TC	6.69	6.69	6.69	6.69	7.09	7.09	7.09	7.09	7.32	7.32	7.32	7.32	7.86	7.86	7.86	7.86
		S/T	0.68	0.75	0.81	0.87	0.57	0.63	0.69	0.75	0.51	0.57	0.63	0.69	0.39	0.44	0.50	0.55
		PI	1.86	1.86	1.86	1.86	1.86	1.86	1.86	1.86	1.86	1.86	1.86	1.86	1.86	1.86	1.86	1.86
	30	TC	6.37	6.37	6.37	6.43	6.77	6.77	6.77	6.77	6.97	6.97	6.97	6.97	7.52	7.52	7.52	7.52
		S/T	0.69	0.75	0.82	0.89	0.57	0.63	0.69	0.76	0.51	0.57	0.64	0.70	0.39	0.44	0.50	0.56
		PI	2.04	2.04	2.04	2.04	2.04	2.04	2.04	2.04	2.05	2.05	2.05	2.05	2.05	2.05	2.05	2.05
	35	TC	6.06	6.06	6.06	6.11	6.43	6.43	6.43	6.43	6.63	6.63	6.74	6.63	7.17	7.17	7.17	7.17
		S/T	0.69	0.76	0.83	0.90	0.57	0.64	0.70	0.77	0.51	0.58	0.64	0.71	0.38	0.44	0.50	0.56
		PI	2.22	2.22	2.22	2.22	2.23	2.23	2.23	2.23	2.24	2.24	2.24	2.24	2.25	2.25	2.25	2.25
	40	TC	5.71	5.71	5.71	5.77	6.07	6.07	6.07	6.07	6.27	6.27	6.34	6.27	6.78	6.78	6.78	6.78
		S/T	0.70	0.78	0.86	0.93	0.57	0.65	0.72	0.79	0.51	0.58	0.65	0.72	0.37	0.44	0.50	0.57
		PI	2.45	2.45	2.45	2.45	2.46	2.46	2.46	2.46	2.47	2.47	2.47	2.47	2.49	2.49	2.49	2.49
46	TC	5.29	5.29	5.29	5.35	5.63	5.63	5.63	5.63	5.83	5.83	5.83	5.83	6.29	6.29	6.29	6.29	
	S/T	0.71	0.79	0.87	0.95	0.58	0.65	0.73	0.80	0.51	0.59	0.66	0.73	0.37	0.44	0.51	0.57	
	PI	2.73	2.73	2.73	2.73	2.74	2.74	2.74	2.74	2.75	2.75	2.75	2.75	2.77	2.77	2.77	2.77	
50	TC	4.94	4.94	5.00	5.06	5.29	5.29	5.29	5.29	5.49	5.49	5.49	5.49	5.95	5.95	5.95	5.95	
	S/T	0.72	0.81	0.89	0.97	0.58	0.66	0.74	0.82	0.51	0.59	0.67	0.75	0.36	0.44	0.51	0.58	
	PI	2.96	2.96	2.96	2.96	2.98	2.98	2.98	2.98	2.98	2.98	2.98	2.98	3.01	3.01	3.01	3.01	
830	-15	TC	7.50	7.50	7.50	7.56	7.88	7.88	7.88	7.88	8.09	8.09	8.09	8.09	8.58	8.58	8.58	8.58
		S/T	0.68	0.75	0.98	1.00	0.55	0.63	0.70	0.76	0.49	0.56	0.63	0.70	0.36	0.42	0.48	0.55
		PI	1.59	1.59	1.59	1.59	1.58	1.58	1.58	1.58	1.58	1.58	1.58	1.58	1.58	1.58	1.58	1.58
	-10	TC	7.45	7.45	7.45	7.51	7.84	7.84	7.84	7.84	8.05	8.05	8.05	8.05	8.55	8.55	8.55	8.55
		S/T	0.68	0.76	0.99	1.00	0.55	0.63	0.70	0.77	0.49	0.56	0.63	0.71	0.36	0.43	0.49	0.55
		PI	1.58	1.58	1.58	1.58	1.58	1.58	1.58	1.58	1.58	1.58	1.58	1.58	1.58	1.58	1.58	1.58
	-5	TC	7.41	7.41	7.41	7.47	7.81	7.81	7.81	7.81	8.02	8.02	8.02	8.02	8.53	8.53	8.53	8.53
		S/T	0.68	0.76	0.99	1.00	0.56	0.63	0.70	0.77	0.50	0.57	0.63	0.71	0.36	0.43	0.49	0.56
		PI	1.58	1.58	1.58	1.58	1.57	1.57	1.57	1.57	1.58	1.58	1.58	1.58	1.58	1.58	1.58	1.58
	0	TC	7.37	7.37	7.37	7.43	7.78	7.78	7.78	7.78	7.99	7.99	7.99	7.99	8.52	8.52	8.52	8.52
		S/T	0.69	0.76	1.00	1.00	0.56	0.64	0.71	0.77	0.50	0.57	0.64	0.72	0.36	0.43	0.49	0.56
		PI	1.58	1.58	1.58	1.58	1.58	1.58	1.58	1.58	1.59	1.59	1.59	1.59	1.59	1.59	1.59	1.59
	5	TC	7.33	7.33	7.33	7.39	7.75	7.75	7.75	7.75	7.97	7.97	7.97	7.97	8.51	8.51	8.51	8.51
		S/T	0.69	0.77	1.00	1.00	0.56	0.64	0.71	0.78	0.50	0.57	0.64	0.72	0.36	0.43	0.49	0.56
		PI	1.60	1.60	1.60	1.60	1.59	1.59	1.59	1.59	1.60	1.60	1.60	1.60	1.60	1.60	1.60	1.60
	10	TC	7.29	7.29	7.29	7.35	7.71	7.71	7.71	7.71	7.93	7.93	7.93	7.93	8.49	8.49	8.49	8.49
		S/T	0.69	0.77	1.00	1.00	0.56	0.64	0.71	0.78	0.50	0.57	0.64	0.72	0.37	0.44	0.50	0.56
		PI	1.63	1.63	1.63	1.63	1.62	1.62	1.62	1.62	1.62	1.62	1.62	1.62	1.62	1.62	1.62	1.62
	15	TC	7.23	7.23	7.23	7.29	7.66	7.66	7.66	7.66	7.89	7.89	7.89	7.89	8.46	8.46	8.46	8.46
		S/T	0.70	0.78	0.86	0.93	0.57	0.65	0.72	0.79	0.51	0.58	0.65	0.73	0.37	0.44	0.50	0.57
		PI	1.67	1.67	1.67	1.67	1.66	1.66	1.66	1.66	1.66	1.66	1.66	1.66	1.65	1.65	1.65	1.65
	20	TC	7.15	7.15	7.15	7.21	7.58	7.58	7.58	7.58	7.81	7.81	7.81	7.81	8.38	8.38	8.38	8.38
		S/T	0.70	0.78	0.86	0.93	0.57	0.65	0.72	0.79	0.51	0.58	0.65	0.73	0.37	0.44	0.50	0.57
		PI	1.72	1.72	1.72	1.72	1.71	1.71	1.71	1.71	1.71	1.71	1.71	1.71	1.70	1.70	1.70	1.70
	25	TC	6.83	6.83	6.83	6.89	7.26	7.26	7.26	7.26	7.46	7.46	7.46	7.46	8.04	8.04	8.04	8.04
		S/T	0.71	0.79	0.87	0.95	0.											

1020	-15	TC	7.68	7.68	7.77	7.86	8.06	8.06	8.06	8.06	8.26	8.26	8.26	8.26	8.79	8.79	8.79	8.79
		S/T	0.71	0.80	1.00	1.00	0.57	0.65	0.73	0.98	0.50	0.58	0.67	0.74	0.35	0.42	0.50	0.58
		PI	1.62	1.62	1.62	1.62	1.62	1.62	1.62	1.62	1.62	1.62	1.62	1.62	1.61	1.61	1.61	1.61
	-10	TC	7.63	7.63	7.72	7.81	8.02	8.02	8.02	8.22	8.22	8.22	8.22	8.22	8.76	8.76	8.76	8.76
		S/T	0.72	0.81	1.00	1.00	0.57	0.65	0.74	0.98	0.50	0.58	0.67	0.75	0.35	0.43	0.50	0.58
		PI	1.62	1.62	1.62	1.62	1.61	1.61	1.61	1.61	1.62	1.62	1.62	1.62	1.62	1.62	1.62	1.62
	-5	TC	7.59	7.59	7.68	7.77	7.99	7.99	7.99	7.99	8.19	8.19	8.19	8.19	8.73	8.73	8.73	8.73
		S/T	0.72	0.81	1.00	1.00	0.58	0.65	0.74	0.99	0.51	0.59	0.67	0.75	0.35	0.43	0.51	0.59
		PI	1.61	1.61	1.61	1.61	1.61	1.61	1.61	1.61	1.62	1.62	1.62	1.62	1.62	1.62	1.62	1.62
	0	TC	7.55	7.55	7.64	7.73	7.96	7.96	7.96	7.96	8.17	8.17	8.17	8.17	8.73	8.73	8.73	8.73
		S/T	0.73	0.81	1.00	1.00	0.58	0.66	0.74	0.99	0.51	0.59	0.68	0.75	0.35	0.43	0.51	0.59
		PI	1.62	1.62	1.62	1.62	1.62	1.62	1.62	1.62	1.62	1.62	1.62	1.62	1.62	1.62	1.62	1.62
	5	TC	7.51	7.51	7.60	7.69	7.93	7.93	7.93	7.93	8.14	8.14	8.14	8.14	8.72	8.72	8.72	8.72
		S/T	0.73	0.82	1.00	1.00	0.58	0.66	0.75	1.00	0.51	0.59	0.68	0.76	0.35	0.43	0.51	0.59
		PI	1.63	1.63	1.63	1.63	1.63	1.63	1.63	1.63	1.63	1.63	1.63	1.63	1.64	1.64	1.64	1.64
	10	TC	7.47	7.47	7.55	7.64	7.89	7.89	7.89	7.89	8.11	8.11	8.11	8.11	8.70	8.70	8.70	8.70
		S/T	0.73	0.82	1.00	1.00	0.58	0.66	0.75	1.00	0.51	0.59	0.68	0.76	0.36	0.44	0.51	0.59
		PI	1.66	1.66	1.66	1.66	1.66	1.66	1.66	1.66	1.66	1.66	1.66	1.66	1.66	1.66	1.66	1.66
	15	TC	7.40	7.40	7.49	7.58	7.83	7.83	7.83	7.83	8.06	8.06	8.06	8.06	8.66	8.66	8.66	8.66
		S/T	0.74	0.83	0.92	1.00	0.59	0.67	0.76	0.85	0.52	0.60	0.69	0.77	0.36	0.44	0.52	0.60
		PI	1.70	1.70	1.70	1.70	1.69	1.69	1.69	1.69	1.70	1.70	1.70	1.70	1.69	1.69	1.69	1.69
	20	TC	7.32	7.32	7.41	7.49	7.75	7.75	7.75	7.75	7.98	7.98	7.98	7.98	8.58	8.58	8.58	8.58
		S/T	0.74	0.83	0.92	1.00	0.59	0.67	0.76	0.85	0.52	0.60	0.69	0.77	0.36	0.44	0.52	0.60
		PI	1.76	1.76	1.76	1.76	1.75	1.75	1.75	1.75	1.75	1.75	1.75	1.75	1.74	1.74	1.74	1.74
	25	TC	6.98	6.98	7.03	7.09	7.41	7.41	7.41	7.41	7.64	7.64	7.64	7.64	8.21	8.21	8.21	8.21
		S/T	0.75	0.84	0.94	1.00	0.59	0.68	0.78	0.87	0.52	0.61	0.70	0.79	0.35	0.44	0.52	0.60
		PI	1.94	1.94	1.94	1.94	1.94	1.94	1.94	1.94	1.94	1.94	1.94	1.94	1.94	1.94	1.94	1.94
	30	TC	6.63	6.63	6.69	6.75	7.06	7.06	7.06	7.12	7.29	7.29	7.29	7.29	7.84	7.84	7.84	7.84
		S/T	0.76	0.86	0.96	1.00	0.60	0.69	0.79	0.88	0.52	0.62	0.71	0.80	0.35	0.44	0.52	0.61
		PI	2.12	2.12	2.12	2.12	2.12	2.12	2.12	2.12	2.13	2.13	2.13	2.13	2.14	2.14	2.14	2.14
	35	TC	6.32	6.32	6.37	6.43	6.72	6.72	6.72	6.78	6.92	6.92	<b>7.03</b>	6.92	7.46	7.46	7.46	7.46
		S/T	0.77	0.88	0.98	1.00	0.60	0.70	0.81	0.90	0.53	0.62	<b>0.72</b>	0.82	0.35	0.44	0.53	0.62
		PI	2.32	2.32	2.32	2.32	2.33	2.33	2.33	2.33	2.34	2.34	<b>2.34</b>	2.34	2.35	2.35	2.35	2.35
	40	TC	5.96	5.99	6.04	6.10	6.35	6.35	6.35	6.41	6.54	6.54	6.60	6.54	7.07	7.07	7.07	7.07
		S/T	0.80	0.91	1.00	1.00	0.62	0.73	0.84	0.95	0.53	0.64	0.75	0.86	0.34	0.44	0.54	0.62
		PI	2.56	2.56	2.56	2.56	2.58	2.58	2.58	2.58	2.58	2.58	2.58	2.58	2.60	2.60	2.60	2.60
	46	TC	5.52	5.58	5.64	5.69	5.89	5.89	5.89	5.95	6.07	6.07	6.07	6.07	6.58	6.58	6.58	6.58
		S/T	0.81	0.93	1.00	1.00	0.62	0.74	0.85	0.97	0.54	0.65	0.76	0.88	0.34	0.44	0.55	0.62
		PI	2.85	2.85	2.85	2.85	2.87	2.87	2.87	2.87	2.87	2.87	2.87	2.87	2.90	2.90	2.90	2.90
	50	TC	5.18	5.23	5.29	5.35	5.52	5.52	5.52	5.58	5.72	5.72	5.72	5.78	6.18	6.18	6.18	6.18
		S/T	0.83	0.96	1.00	1.00	0.63	0.76	0.88	1.00	0.54	0.66	0.78	0.90	0.33	0.45	0.56	0.62
		PI	3.09	3.09	3.09	3.09	3.11	3.11	3.11	3.11	3.11	3.11	3.11	3.11	3.13	3.13	3.13	3.13

TC:Total Cooling Capacity (kW)

S/T:Sensible Cooling Capacity Ratio

PI:Power Input(kW)

**Note: The table shows the case where the operation frequency of a compressor is fixed.**

## 6.2 Heating

MM2-Y 27M / ML3-Y 27M + IM2-XY 20M-27M / IL3-XY 20M-27M								[SI_Unit]	
INDOOR AIRFLOW (CMH)	HEATING PERFORMANCE AT INDOOR DRY BULB TEMPERATURE								
	OUTDOOR DB(°C)	TC:TOTAL CAPACITY IN KILOWATTS (KW)				PI:TOTAL POWER IN KILOWATTS (KW)			
		Indoor Conditions (DB °C )				Indoor Conditions (DB °C )			
		16.0	20.0	22.0	24.0	16.0	20.0	22.0	24.0
230	-15.0	2.17	2.17	2.14	2.14	0.85	0.88	0.86	0.87
	-10.0	2.32	2.32	2.29	2.29	0.91	0.94	0.92	0.93
	-7.0	2.43	2.43	2.40	2.40	0.97	1.00	0.98	0.99
	-5.6	2.45	2.45	2.43	2.43	0.94	0.95	0.96	0.96
	-2.8	2.48	2.45	2.45	2.43	0.90	0.91	0.91	0.92
	0.0	2.45	2.43	2.43	2.40	0.86	0.87	0.87	0.87
	2.8	2.54	2.51	2.48	2.48	0.83	0.83	0.83	0.84
	5.6	2.69	2.66	2.63	2.63	0.79	0.80	0.80	0.80
	7.0	2.87	2.84	2.81	2.79	0.78	0.76	0.78	0.78
	11.1	2.96	2.93	2.90	2.87	0.72	0.72	0.72	0.72
	13.9	3.05	2.99	2.96	2.96	0.68	0.68	0.68	0.68
	16.7	3.10	3.05	3.05	3.02	0.64	0.64	0.64	0.64
18.0	3.13	3.10	3.08	3.05	0.63	0.62	0.62	0.62	
309	-15.0	2.24	2.21	2.21	2.19	0.85	0.89	0.87	0.88
	-10.0	2.39	2.36	2.36	2.33	0.91	0.95	0.93	0.94
	-7.0	2.50	2.47	2.47	2.45	0.97	1.01	0.99	1.00
	-5.6	2.51	2.48	2.48	2.45	0.95	0.96	0.97	0.97
	-2.8	2.54	2.51	2.48	2.48	0.91	0.92	0.92	0.93
	0.0	2.51	2.48	2.48	2.45	0.87	0.88	0.88	0.88
	2.8	2.60	2.57	2.54	2.51	0.83	0.84	0.84	0.85
	5.6	2.74	2.71	2.69	2.69	0.80	0.80	0.81	0.81
	7.0	2.93	2.90	2.87	2.84	0.79	0.77	0.79	0.79
	11.1	3.02	2.99	2.96	2.93	0.73	0.73	0.73	0.73
	13.9	3.10	3.05	3.02	3.02	0.69	0.69	0.69	0.69
	16.7	3.16	3.13	3.10	3.08	0.65	0.65	0.65	0.65
18.0	3.19	3.16	3.13	3.10	0.64	0.63	0.63	0.63	
416	-15.0	2.25	2.25	2.22	2.22	0.87	0.90	0.88	0.89
	-10.0	2.40	2.40	2.37	2.37	0.93	0.96	0.94	0.95
	-7.0	2.51	2.51	2.48	2.48	0.99	1.02	1.00	1.01
	-5.6	2.54	2.54	2.51	2.51	0.96	0.97	0.98	0.98
	-2.8	2.57	2.54	2.51	2.51	0.92	0.93	0.93	0.94
	0.0	2.54	2.51	2.51	2.48	0.88	0.89	0.89	0.89
	2.8	2.63	2.60	2.57	2.54	0.84	0.85	0.85	0.86
	5.6	2.77	2.74	2.71	2.71	0.81	0.81	0.82	0.82
	7.0	2.96	2.93	2.90	2.87	0.80	0.78	0.80	0.80
	11.1	3.05	3.02	2.99	2.96	0.74	0.74	0.74	0.74
	13.9	3.13	3.08	3.05	3.05	0.70	0.70	0.70	0.70
	16.7	3.19	3.13	3.13	3.10	0.66	0.66	0.66	0.66
18.0	3.22	3.19	3.16	3.13	0.65	0.64	0.64	0.64	

Note: The table shows the case where the operation frequency of a compressor is fixed.

MM2-Y 35M / ML3-Y 35M+ IM2-XY 35M / IL3-XY 35M								[SI_Unit]	
INDOOR AIRFLOW (CMH)	HEATING PERFORMANCE AT INDOOR DRY BULB TEMPERATURE								
	OUTDOOR DB(°C)	TC:TOTAL CAPACITY IN KILOWATTS (KW)				PI:TOTAL POWER IN KILOWATTS (KW)			
		Indoor Conditions (DB °C )				Indoor Conditions (DB °C )			
		16.0	20.0	22.0	24.0	16.0	20.0	22.0	24.0
395	-15.0	2.66	2.63	2.61	2.61	1.03	1.06	1.05	1.06
	-10.0	2.84	2.81	2.79	2.79	1.10	1.13	1.12	1.13
	-7.0	2.98	2.95	2.92	2.92	1.16	1.20	1.19	1.20
	-5.6	3.03	3.01	2.98	2.98	1.15	1.16	1.17	1.18
	-2.8	3.09	3.06	3.03	3.01	1.12	1.14	1.15	1.16
	0.0	3.09	3.06	3.03	3.03	1.10	1.11	1.12	1.13
	2.8	3.24	3.18	3.15	3.15	1.08	1.09	1.10	1.11
	5.6	3.47	3.41	3.38	3.38	1.06	1.08	1.08	1.09
	7.0	3.76	3.69	3.64	3.61	1.05	1.06	1.08	1.08
	11.1	3.87	3.84	3.81	3.78	1.02	1.03	1.04	1.05
	13.9	4.01	3.96	3.93	3.90	0.99	1.01	1.01	1.02
	16.7	4.13	4.07	4.04	4.01	0.97	0.98	0.99	0.99
18.0	4.19	4.13	4.10	4.07	0.96	0.97	0.98	0.98	
477	-15.0	2.75	2.70	2.70	2.67	1.04	1.07	1.07	1.08
	-10.0	2.94	2.88	2.88	2.86	1.11	1.15	1.14	1.15
	-7.0	3.08	3.02	3.02	2.99	1.17	1.22	1.21	1.22
	-5.6	3.12	3.06	3.06	3.03	1.16	1.18	1.19	1.20
	-2.8	3.15	3.12	3.12	3.09	1.14	1.16	1.16	1.17
	0.0	3.18	3.15	3.12	3.09	1.11	1.13	1.13	1.14
	2.8	3.29	3.27	3.24	3.21	1.09	1.11	1.11	1.12
	5.6	3.55	3.50	3.47	3.44	1.07	1.09	1.09	1.10
	7.0	3.84	3.78	3.72	3.69	1.06	1.07	1.09	1.09
	11.1	3.98	3.93	3.90	3.87	1.03	1.04	1.05	1.05
	13.9	4.10	4.04	4.01	3.98	1.00	1.02	1.02	1.03
	16.7	4.22	4.16	4.13	4.10	0.98	0.99	1.00	1.00
18.0	4.30	4.22	4.19	4.16	0.97	0.98	0.98	0.99	
584	-15.0	2.76	2.74	2.71	2.71	1.05	1.09	1.08	1.09
	-10.0	2.95	2.92	2.90	2.90	1.12	1.16	1.15	1.16
	-7.0	3.09	3.06	3.03	3.03	1.19	1.23	1.22	1.23
	-5.6	3.15	3.12	3.09	3.09	1.17	1.19	1.20	1.21
	-2.8	3.21	3.15	3.15	3.12	1.15	1.16	1.17	1.18
	0.0	3.21	3.18	3.15	3.12	1.12	1.14	1.15	1.16
	2.8	3.32	3.29	3.27	3.24	1.10	1.12	1.13	1.13
	5.6	3.58	3.53	3.50	3.47	1.08	1.10	1.10	1.11
	7.0	3.87	3.81	3.75	3.72	1.07	1.08	1.10	1.10
	11.1	4.01	3.96	3.93	3.90	1.04	1.05	1.06	1.06
	13.9	4.13	4.07	4.04	4.01	1.01	1.02	1.03	1.04
	16.7	4.25	4.19	4.16	4.13	0.99	1.00	1.00	1.01
18.0	4.30	4.25	4.22	4.19	0.97	0.98	0.99	1.00	

Note: The table shows the case where the operation frequency of a compressor is fixed.

MM2-Y 53M / ML3-Y 53M+ IM2-XY 53M / IL3-XY 53M								[SI_Unit]	
INDOOR AIRFLOW (CMH)	HEATING PERFORMANCE AT INDOOR DRY BULB TEMPERATURE								
	OUTDOOR DB(°C)	TC:TOTAL CAPACITY IN KILOWATTS (KW)				PI:TOTAL POWER IN KILOWATTS (KW)			
		Indoor Conditions (DB °C )				Indoor Conditions (DB °C )			
		16.0	20.0	22.0	24.0	16.0	20.0	22.0	24.0
420	-15.0	4.15	4.10	4.10	4.08	1.60	1.65	1.63	1.64
	-10.0	4.44	4.38	4.38	4.35	1.71	1.76	1.73	1.75
	-7.0	4.65	4.59	4.59	4.56	1.81	1.87	1.84	1.86
	-5.6	4.68	4.62	4.62	4.59	1.77	1.79	1.80	1.81
	-2.8	4.70	4.65	4.62	4.62	1.70	1.72	1.73	1.74
	0.0	4.68	4.65	4.62	4.59	1.63	1.64	1.65	1.66
	2.8	4.82	4.76	4.73	4.70	1.57	1.58	1.59	1.60
	5.6	5.14	5.08	5.02	5.00	1.52	1.53	1.53	1.54
	7.0	5.46	5.39	5.31	5.28	1.49	1.47	1.50	1.51
	11.1	5.63	5.54	5.51	5.48	1.40	1.40	1.40	1.41
	13.9	5.77	5.68	5.66	5.60	1.33	1.34	1.34	1.34
	16.7	5.92	5.83	5.77	5.74	1.27	1.27	1.27	1.27
18.0	5.97	5.89	5.86	5.80	1.24	1.24	1.24	1.24	
500	-15.0	4.25	4.19	4.17	4.14	1.62	1.67	1.64	1.66
	-10.0	4.53	4.48	4.45	4.42	1.72	1.78	1.75	1.77
	-7.0	4.75	4.69	4.66	4.63	1.83	1.89	1.86	1.88
	-5.6	4.79	4.73	4.70	4.68	1.79	1.81	1.82	1.83
	-2.8	4.82	4.76	4.73	4.70	1.71	1.73	1.74	1.75
	0.0	4.79	4.73	4.70	4.68	1.64	1.66	1.67	1.67
	2.8	4.94	4.88	4.85	4.82	1.58	1.60	1.60	1.61
	5.6	5.26	5.17	5.14	5.11	1.53	1.54	1.54	1.55
	7.0	5.60	5.51	5.42	5.39	1.50	1.48	1.51	1.52
	11.1	5.74	5.66	5.63	5.60	1.41	1.41	1.41	1.41
	13.9	5.89	5.80	5.77	5.71	1.34	1.34	1.34	1.34
	16.7	6.03	5.95	5.92	5.86	1.28	1.27	1.27	1.27
18.0	6.12	6.00	5.97	5.92	1.25	1.24	1.24	1.24	
730	-15.0	4.28	4.23	4.23	4.21	1.63	1.69	1.66	1.67
	-10.0	4.57	4.52	4.52	4.49	1.74	1.80	1.77	1.78
	-7.0	4.79	4.73	4.73	4.71	1.85	1.91	1.88	1.89
	-5.6	4.82	4.76	4.76	4.73	1.80	1.83	1.84	1.85
	-2.8	4.85	4.79	4.79	4.76	1.73	1.75	1.76	1.77
	0.0	4.85	4.79	4.76	4.73	1.66	1.68	1.69	1.69
	2.8	5.00	4.94	4.88	4.85	1.60	1.62	1.62	1.63
	5.6	5.31	5.23	5.20	5.17	1.55	1.56	1.56	1.57
	7.0	5.66	5.57	5.48	5.45	1.52	1.50	1.53	1.54
	11.1	5.80	5.74	5.68	5.66	1.43	1.43	1.43	1.44
	13.9	5.95	5.86	5.83	5.80	1.36	1.36	1.36	1.36
	16.7	6.09	6.00	5.97	5.92	1.30	1.30	1.29	1.29
18.0	6.18	6.09	6.03	6.00	1.27	1.26	1.26	1.26	

Note: The table shows the case where the operation frequency of a compressor is fixed.

MM2-Y 70M / ML3-Y 70M + 1M2-XY 70M / IL3-XY 70M								[SI_Unit]	
INDOOR AIRFLOW (CMH)	HEATING PERFORMANCE AT INDOOR DRY BULB TEMPERATURE								
	OUTDOOR DB(°C)	TC:TOTAL CAPACITY IN KILOWATTS (KW)				PI:TOTAL POWER IN KILOWATTS (KW)			
		Indoor Conditions (DB °C )				Indoor Conditions (DB °C )			
		16.0	20.0	22.0	24.0	16.0	20.0	22.0	24.0
640	-15.0	6.30	6.25	6.23	6.20	2.78	2.88	2.80	2.81
	-10.0	6.73	6.68	6.65	6.62	2.96	3.07	2.99	3.00
	-7.0	7.05	6.99	6.96	6.93	3.15	3.27	3.18	3.19
	-5.6	6.94	6.88	6.85	6.82	3.05	3.06	3.06	3.07
	-2.8	6.85	6.76	6.73	6.70	2.85	2.85	2.85	2.85
	0.0	6.65	6.59	6.53	6.50	2.65	2.64	2.64	2.64
	2.8	6.67	6.59	6.56	6.50	2.47	2.46	2.45	2.45
	5.6	6.91	6.82	6.79	6.73	2.31	2.28	2.27	2.26
	7.0	7.19	7.10	7.07	7.01	2.22	2.09	2.18	2.17
	11.1	7.24	7.15	7.10	7.04	1.94	1.90	1.88	1.86
	13.9	7.27	7.15	7.12	7.07	1.76	1.71	1.68	1.66
	16.7	7.30	7.18	7.12	7.07	1.58	1.52	1.49	1.46
18.0	7.30	7.18	7.12	7.07	1.49	1.43	1.40	1.36	
830	-15.0	6.42	6.37	6.34	6.32	2.81	2.91	2.83	2.84
	-10.0	6.86	6.80	6.77	6.75	3.00	3.11	3.02	3.03
	-7.0	7.19	7.13	7.10	7.07	3.19	3.30	3.21	3.22
	-5.6	7.08	7.02	6.99	6.96	3.08	3.09	3.10	3.10
	-2.8	6.96	6.91	6.88	6.82	2.88	2.88	2.88	2.88
	0.0	6.79	6.70	6.67	6.62	2.68	2.67	2.67	2.67
	2.8	6.82	6.73	6.67	6.65	2.50	2.48	2.48	2.47
	5.6	7.05	6.96	6.94	6.88	2.33	2.31	2.30	2.28
	7.0	7.33	7.24	7.21	7.15	2.24	2.11	2.20	2.19
	11.1	7.39	7.30	7.24	7.18	1.96	1.92	1.90	1.88
	13.9	7.41	7.33	7.27	7.21	1.77	1.72	1.70	1.67
	16.7	7.44	7.33	7.27	7.21	1.59	1.53	1.50	1.47
18.0	7.47	7.36	7.30	7.24	1.50	1.44	1.41	1.37	
1020	-15.0	6.51	6.43	6.41	6.38	2.84	2.94	2.86	2.86
	-10.0	6.95	6.87	6.84	6.81	3.03	3.14	3.06	3.06
	-7.0	7.29	7.20	7.17	7.14	3.22	3.34	3.25	3.25
	-5.6	7.17	7.08	7.05	7.02	3.11	3.12	3.13	3.13
	-2.8	7.05	6.96	6.94	6.91	2.91	2.91	2.91	2.91
	0.0	6.85	6.79	6.73	6.70	2.71	2.70	2.70	2.69
	2.8	6.88	6.79	6.76	6.73	2.52	2.51	2.50	2.49
	5.6	7.14	7.05	6.99	6.96	2.35	2.33	2.32	2.31
	7.0	7.42	7.33	7.30	7.24	2.26	2.13	2.22	2.21
	11.1	7.47	7.39	7.33	7.27	1.98	1.94	1.92	1.90
	13.9	7.53	7.41	7.36	7.30	1.79	1.74	1.71	1.69
	16.7	7.56	7.44	7.39	7.33	1.60	1.55	1.52	1.49
18.0	7.56	7.44	7.39	7.33	1.51	1.45	1.42	1.39	

Note: The table shows the case where the operation frequency of a compressor is fixed.

## 7. Noise Criterion Curves

### 7.1 Indoor Unit

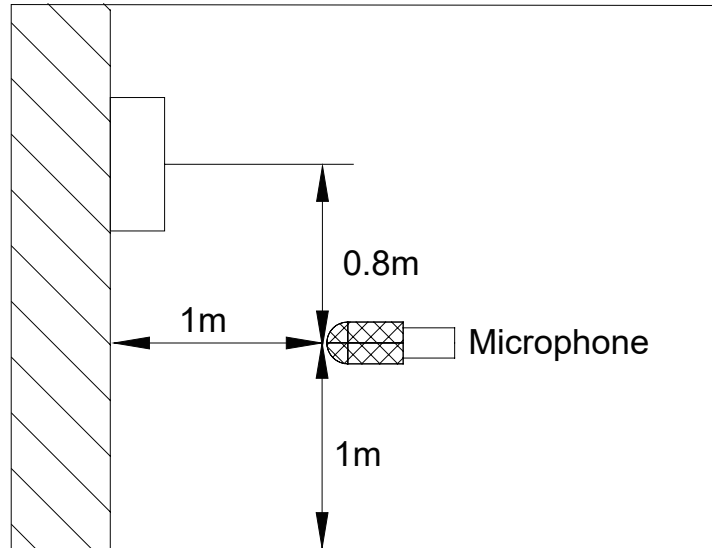

Notes:

- Sound measured at 1.0m away from the center of the unit.
- Data is valid at free field condition
- Data is valid at nominal operation condition
- Reference acoustic pressure  $OdB = 20\mu Pa$
- Sound level will vary depending on a range of factors such as the construction -(acoustic absorption coefficient) of particular room in which the equipment is installed.
- The operating conditions are assumed to be standard.

20M / 27M

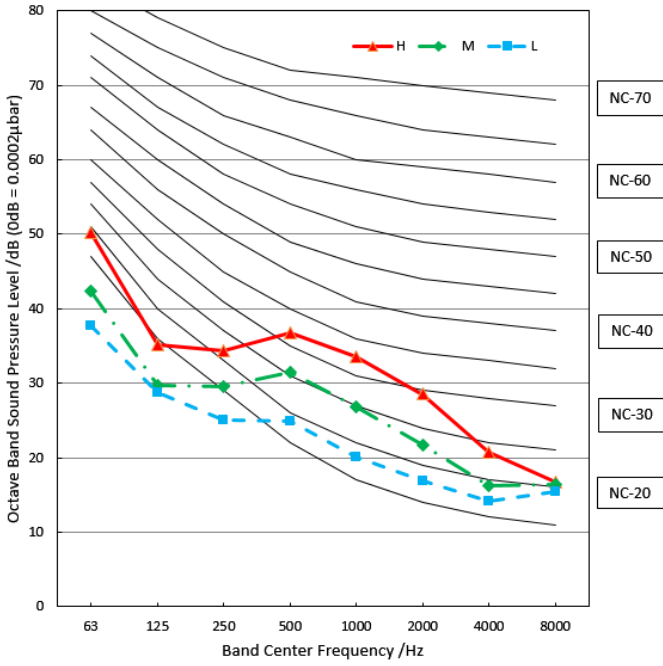

35M

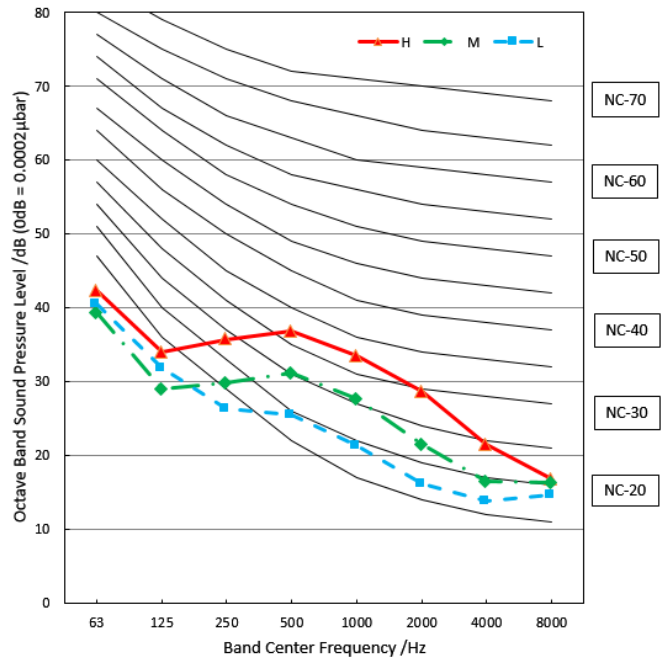

53M

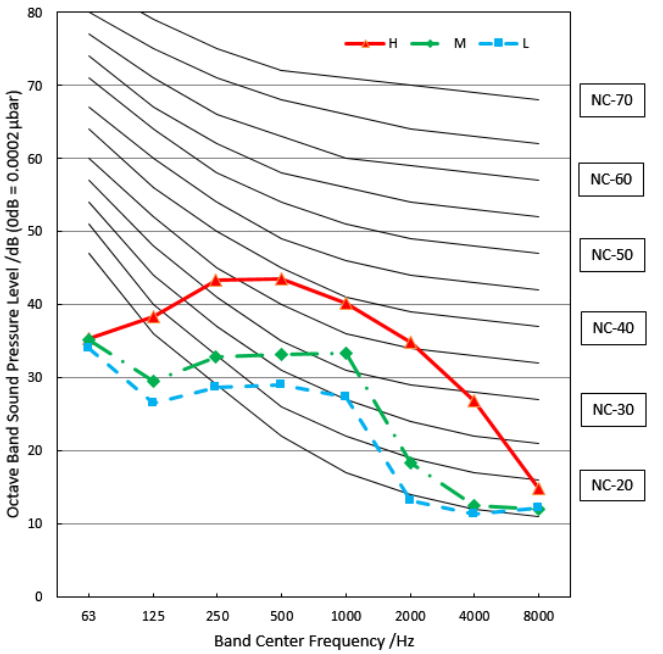

70M

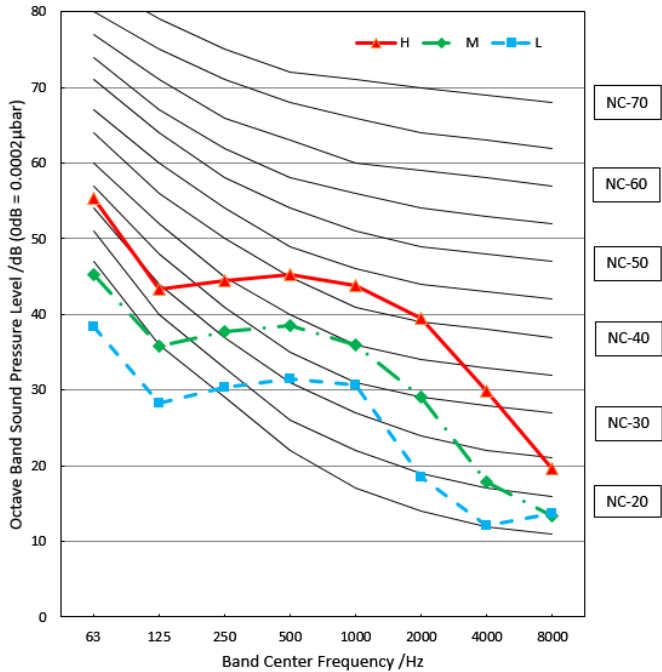

## 7.2 Outdoor Unit

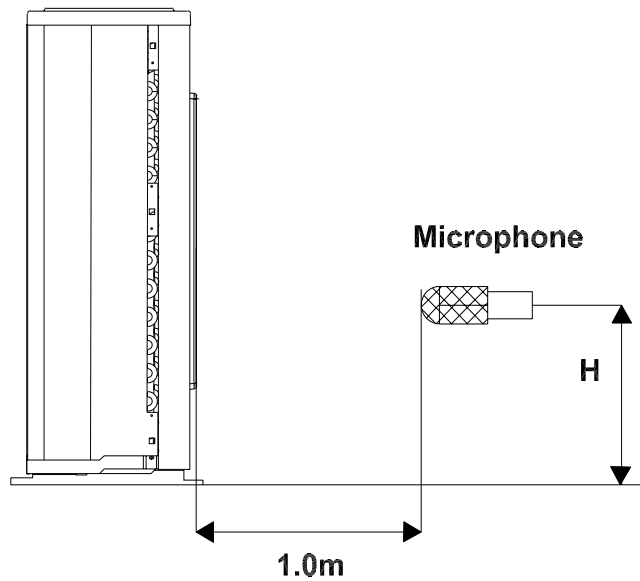

Note:  $H = 0.5 \times$  height of outdoor unit

### Notes:

- Sound measured at 1.0m away from the center of the unit.
- Data is valid at free field condition
- Data is valid at nominal operation condition
- Reference acoustic pressure  $OdB=20\mu Pa$
- Sound level will vary depending on arrangement of factors such as the construction (acoustic absorption coefficient) of particular room in which the equipment is installed.
- The operating conditions are assumed to be standard.

27M

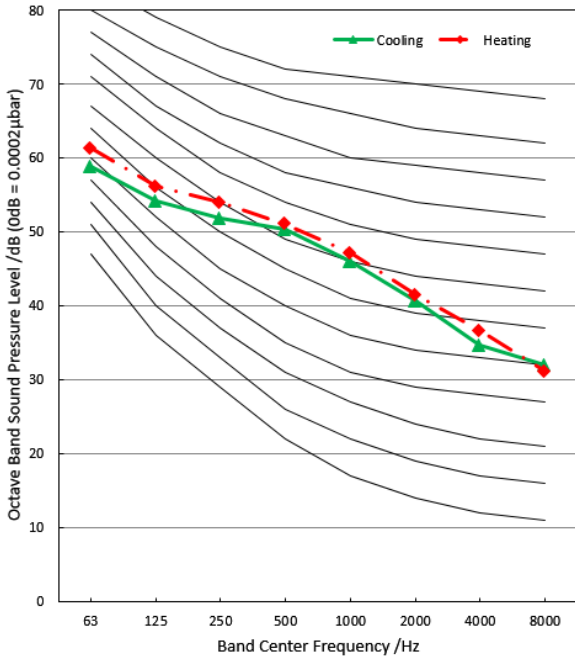

35M

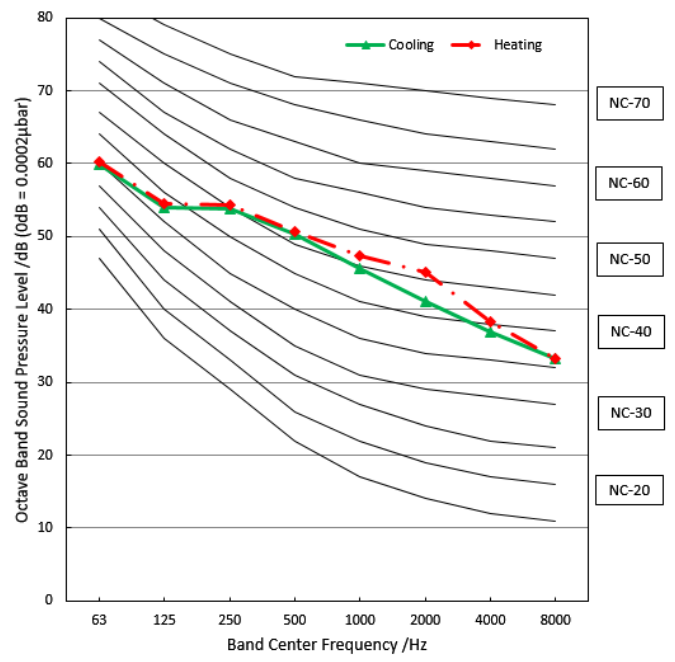

53M

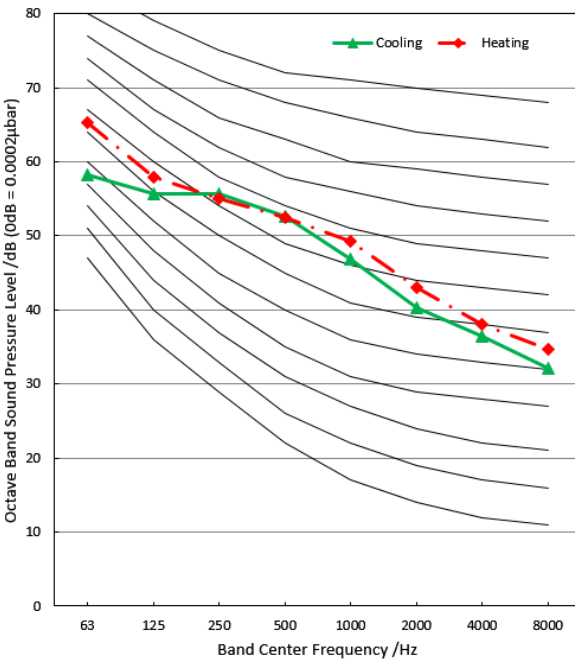

70M

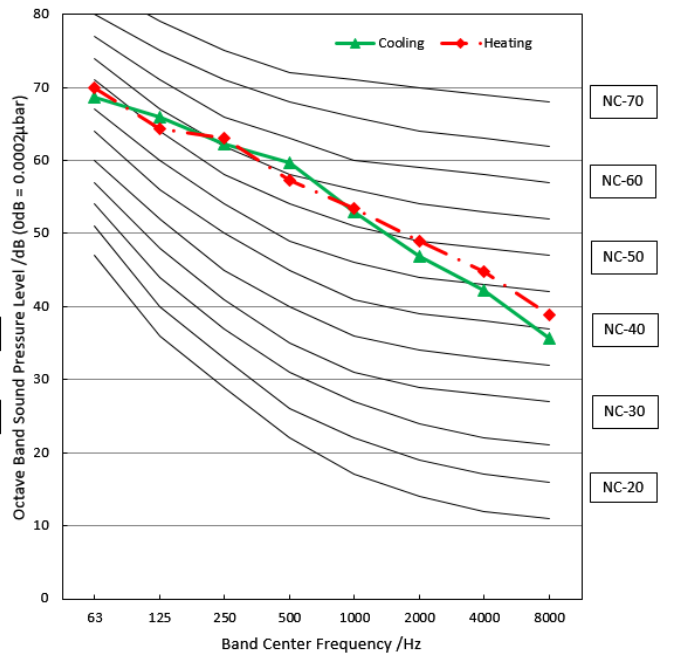

## 8. Electrical Characteristics

Model	Indoor Unit			Power Supply		IFM	
	Phase	Hz	Voltage	MCA	MFA	kW	FLA
IM2-XY 20M / IL3-XY 20M IM2-XY 27M / IL3-XY 27M	1	50	220~240	--	--	0.02	0.16
IM2-XY 35M / IL3-XY 35M				--	--	0.02	0.16
IM2-XY 53M / IL3-XY 53M				--	--	0.03	0.11
IM2-XY 70M / IL3-XY 70M				--	--	0.058	0.21

Model	Outdoor Unit			Power Supply		Compressor		OFM		
	Phase	Hz	Voltage	MCA	MFA	MSC	RLA	Qty	kW	FLA
MM2-Y 27M / ML3-Y 27M	1	50	220~240	8.11	13.76	/	5.65	1	0.034	0.89
MM2-Y 35M / ML3-Y 35M				8.11	13.76	/	5.65	1	0.034	0.89
MM2-Y 53M / ML3-Y 53M				10.38	17.88	/	7.5	1	0.034	0.89
MM2-Y 70M / ML3-Y 70M				12.84	22.29	/	9.45	1	0.08	0.82

Notes:

MCA: Minimum Circuit Amperes (A)

MFA: Maximum Fuse Amperes (A)

MSC: Maximum Starting Current

RLA: Rated Load Amperes (A)

IFM: Indoor Fan Motor

OFM: Outdoor Fan Motor

FLA: Full Load Amperes (A)

kW: Fan Motor rated output(kW)

---

# Product Features

## Contents

<b>1.</b>	<b>Operation Modes and Functions .....</b>	<b>37</b>
1.1	Abbreviation.....	37
1.2	Safety Features .....	37
1.3	Display Function .....	38
1.4	Fan Mode.....	39
1.5	Cooling Mode .....	39
1.6	Heating Mode (For heat pump models).....	39
1.7	Auto-mode.....	40
1.8	Drying Mode .....	41
1.9	Forced Operation Function .....	41
1.10	Timer Function .....	41
1.11	Sleep Function.....	41
1.12	Auto-Restart Function.....	41
1.13	Refrigerant Leakage Detection.....	42
1.14	Louver Position Memory Function .....	42
1.15	8°C Heating(Optional) .....	42
1.16	Self Clean(Optional).....	42
1.17	Follow Me(Optional) .....	42
1.18	Silence (Optional).....	42
<b>2.</b>	<b>Remote Controller Functions .....</b>	<b>43</b>
2.1	Infrared Wireless Remote Controller.....	43

## 1. Operation Modes and Functions

### 1.1 Abbreviation

Unit element abbreviations

Abbreviation	Element
T1	Indoor room temperature
T2	Coil temperature of evaporator
T3	Coil temperature of condenser
T4	Outdoor ambient temperature
TP	Compressor discharge temperature

### 1.2 Safety Features

#### Compressor three-minute delay at restart

Compressor functions are delayed for up to one minute upon the first startup of the unit, and are delayed for up to three minutes upon subsequent unit restarts.

#### Automatic shutoff based on discharge temperature

If the compressor discharge temperature exceeds 108°C for five seconds, the compressor ceases operation.

#### Automatic shutoff based on fan speed

If the indoor fan speed registers below 300RPM for an extended period of time, the unit ceases operation and the corresponding error code is displayed on the indoor unit.

#### Inverter module protection

The inverter module has an automatic shutoff mechanism based on the unit's current, voltage, and temperature. If automatic shutoff is initiated, the corresponding error code is displayed on the indoor unit and the unit ceases operation.

#### Indoor fan delayed operation

When the unit starts, the louver is automatically activated and the indoor fan will operate after a period of 7 seconds.

If the unit is in heating mode, the indoor fan is regulated by the anti-cold wind function.

#### Compressor preheating

Preheating is automatically activated when T4 sensor is lower than 3°C.

#### Sensor redundancy and automatic shutoff

If one temperature sensor malfunctions, the air conditioner continues operation and displays the corresponding error code, allowing for emergency use.

When more than one temperature sensor is malfunctioning, the air conditioner ceases operation.

#### Refrigerant leakage detection

This function is active only when mode is selected. It will detect if the compressor is being damaged by refrigerant leakage or by compressor overload. This is measured using the coil temperature of evaporator T2 when the compressor is in operation.

### 1.3 Display Function

Unit display functions

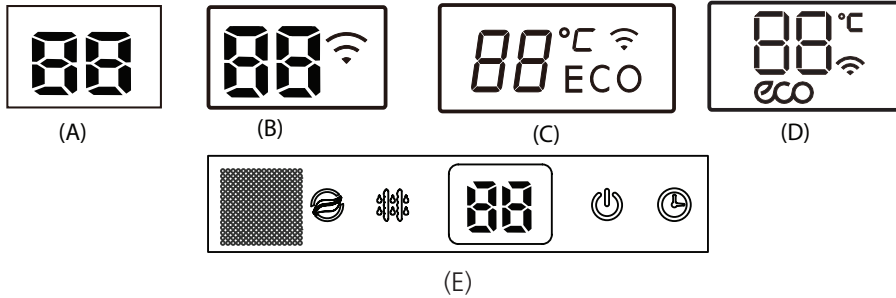

Display	Function	
	Fresh(available on select units only)	
	Defrost	
	When the unit is on	
	When TIMER is on	
ECO	ECO function (available on select units only)	
°C	Lights up in different colour according to the operation mode(some units): Under COOL and DRY mode, it displays as cool colour.Under HEAT mode, it displays as warm colour.	
	when Wireless Control feature is activated(some units)	
88	Temperature value	Temperature
	0n (3s)	Activation of Timer ON, Fresh, Swing, Turbo, or Silent
	0F (3s)	Cancellation of Timer OFF, Fresh, Swing, Turbo, or Silent
	df	Defrost
	cf	Warming in heating mode
	SC	Self-clean (available on select units only)
	FP	Heating in room temperature under 8°C

Note: Please select the display function according to your purchase product.

## 1.4 Fan Mode

When fan mode is activated:

- The outdoor fan and compressor are stopped.
- Temperature control is disabled and no temperature setting is displayed.
- The indoor fan speed can be set to high, med, low, or auto.
- The louver operations are identical to those in cooling mode.
- Auto fan: In fan-only mode, AC operates the same as auto fan in cooling mode with the temperature set at 24°C.

## 1.5 Cooling Mode

### 1.5.1 Compressor Control

Cooling temperature compensation( $\Delta T5$ ) is a well-setting parameter of EEPROM. It's value ranges from -2°C to 2°C. The default value is 0.

- When  $T1-Ts < \Delta T5-2\text{ }^{\circ}\text{C}$  (3.6°F), the compressor ceases operation.
- When  $T1-Ts > \Delta T5+3\text{ }^{\circ}\text{C}$  (5.4°F), the compressor continues operation.
- When the AC is operating in mute mode, the compressor operates at a low frequency.
- When the current exceeds the preset value, the current protection function activates and the compressor ceases operation.

### 1.5.2 Indoor Fan Control

- In cooling mode, the indoor fan operates continuously. The fan speed can be set to high, medium, low, or auto.
- If the compressor ceases operation when the configured temperature is reached, the indoor fan motor operates at the minimum or configured speed.
- The indoor fan is controlled as below:

Setting fan speed	T1-Td °C(°F)	Actual fan speed
H	A	H+ (H+=H+G)
	B	H (=H)
	C	H- (H-=H-G)
M	D	M+ (M+=M+Z)
	E	M (M=M)
	F	M- (M-=M-Z)
L	G	L+ (L+=L+D)
	H	L (L=L)
	I	L- (L-=L-D)

- The auto fan acts as below rules:

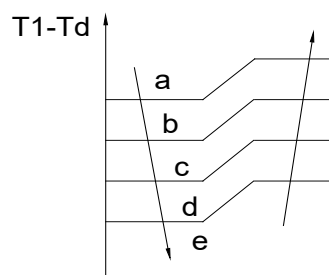

### 1.5.3 Outdoor Fan Control

- The outdoor unit will be run at different fan speed according to T4 and compressor frequency.
- For different outdoor units, the fan speeds are different.

### 1.5.4 Condenser Temperature Protection

When condenser temperature is more than setting value, the compressor ceases operation..

### 1.5.5 Evaporator Temperature Protection

When evaporator temperature drops below a configured value, the compressor ceases operations.

## 1.6 Heating Mode (For heat pump models)

### 1.6.1 Compressor Control

Heating temperature compensation( $\Delta T3$ ) is a well-setting parameter of EEPROM. It's value ranges from -6°C to 6°C.

- When  $T1-Ts > \Delta T3$ , the compressor ceases operation.
- When  $T1-Ts < -\Delta T3-1.5\text{ }^{\circ}\text{C}$  (2.7°F), the compressor continues operation.
- When the AC is operating in mute mode, the compressor operates at a low frequency.
- When the current exceeds the preset value, the current protection function activates and the compressor

### 1.6.2 Indoor Fan Control:

- When the compressor is on, the indoor fan speed can be set to high, medium, low, or auto. And the anti-cold wind function has the priority.
- Anti-cold air function
  - The indoor fan is controlled by the indoor temperature T1 and indoor unit coil temperature T2.

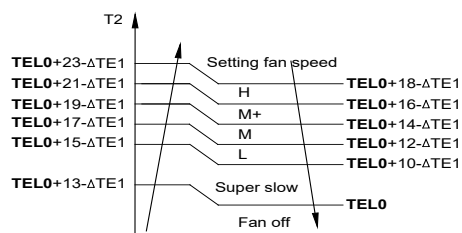

$T1 \geq 19^{\circ}\text{C} (66.2^{\circ}\text{F})$	$\Delta\text{TE1}=0$
$15^{\circ}\text{C} (59^{\circ}\text{F}) \leq T1 \leq 18^{\circ}\text{C} (64.4^{\circ}\text{F})$	$\Delta\text{TE1}=19^{\circ}\text{C}-T1$ ( $34.2^{\circ}\text{F}-T1$ )
$T1 < 15^{\circ}\text{C} (59^{\circ}\text{F})$	$\Delta\text{TE1}=4^{\circ}\text{C} (7.2^{\circ}\text{F})$

- When the indoor temperature T1 reaches the setting temperature, the compressor continues operation, the indoor fan motor runs at the minimum speed or setting speed. (The anti-cold air function is valid).
- The indoor fan is controlled as below:

Setting fan speed	T1-Td (°C)	Actual fan speed
H	↑	H (H=H+G)
	→	H (=H)
	↓	H (H=H+G)
M	↑	M (M=M+Z)
	→	M (=M)
	↓	M (M=M+Z)
L	↑	L (L=L+D)
	→	L (=L)
	↓	L (L=L+D)

- Auto fan action in heating mode:

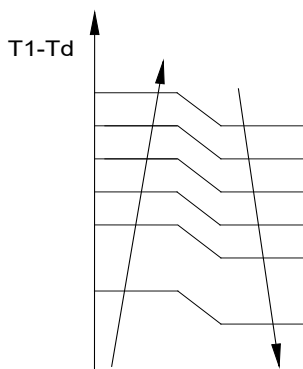

### 1.6.3 Outdoor Fan Control:

- The outdoor unit will be run at different fan speed according to T4 and compressor frequency.
- For different outdoor units, the fan speeds are different.

### 1.6.4 Defrosting mode

- The unit enters defrosting mode according to the temperature value of T3 and T4 as well as the compressor running time.

- In defrosting mode, the compressor continues to run, the indoor and outdoor motor will cease operation, the defrost light of the indoor unit will turn on, and the "DF" symbol is displayed.

- If any one of the following conditions is satisfied, defrosting ends and the machine switches to normal heating mode:
  - T3 rises above TCDE1.
  - T3 maintained above TCDE2 for 80 seconds.
  - Unit runs for 15 minutes consecutively in defrosting mode.
- If T4 is lower than or equal to  $-22^{\circ}\text{C} (-7.6^{\circ}\text{F})$  and compressor running time is more than TIMING\_DEFROST\_TIME, if any one of the following conditions is satisfied, defrosting ends and the machine switches to normal heating mode:
  - Unit runs for 10 minutes consecutively in defrosting mode.
  - T3 rises above  $10^{\circ}\text{C} (50^{\circ}\text{F})$ .

### For some models:

- T3 is lower than  $3^{\circ}\text{C} (37.4^{\circ}\text{F})$  and compressor running time is more than 120 minutes, at this time, if T3 is lower than  $\text{TCDI1}+4^{\circ}\text{C} (39.2^{\circ}\text{F})$  for 3 minutes, the unit enters defrosting mode. If any one of the following conditions is satisfied, defrosting ends and the machine switches to normal heating mode:
  - T3 rises above  $\text{TCDE1}+4^{\circ}\text{C} (39.2^{\circ}\text{F})$ .
  - T3 maintained above  $\text{TCDE2}+4^{\circ}\text{C} (39.2^{\circ}\text{F})$  for 80 seconds.
  - Unit runs for 15 minutes consecutively in defrosting mode.

### 1.6.5 Evaporator Temperature Protection

When the evaporator temperature exceeds a preset protection value, the compressor ceases operation.

### 1.7 Auto-mode

- This mode can be selected with the remote controller.
- In auto mode, the machine selects cooling, heating, or fan-only mode on the basis of  $\Delta T$  ( $\Delta T = T1 - T_s$ ).

$\Delta T$	Running mode
$\Delta T > 2^{\circ}\text{C}$	Cooling
$-2^{\circ}\text{C} \leq \Delta T \leq 2^{\circ}\text{C}$	Fan-only
$\Delta T < -2^{\circ}\text{C}$	Heating*

Heating\*: In auto mode, cooling only models run the fan

- The louver operates same as in relevant mode.
- If the machine switches mode between heating and cooling, the compressor will keep stopping for 15 minutes and then choose mode according to T1-Ts.
- If the setting temperature is modified, the machine will choose running function again.

## 1.8 Drying mode

- Indoor fan speed is fixed at breeze and can't be changed. The louver angle is the same as in cooling mode.
- All protections are active and the same as that in cooling mode.

## 1.9 Forced operation function

Press the AUTO/COOL button, the AC will run as below sequence:

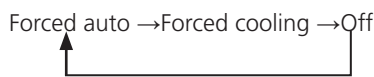

- Forced cooling mode:

The compressor and outdoor fan continue to run and the indoor fan runs at breeze speed. After running for 30 minutes, the AC will switch to auto mode with a preset temperature of 24°C(76°F).

- Forced auto mode:

Forced auto mode operates the same as normal auto mode with a preset temperature of 24°C(76°F).

- The unit exits forced operation when it receives the following signals:
  - Switch on
  - Switch off
  - Timer on
  - Timer off
  - Changes in:
    - mode
    - fan speed
    - sleep mode
    - Follow me
- Forced defrosting mode:
  - Press AUTO/COOL button continuously for 5s under forced cooling mode to enter this mode.
  - Indoor fan will stop, defrosting lamp will light on.
  - Quit this mode and turn off the unit when:
    - quit normal defrosting

- turn off by RC
- press AUTO/COOL button continuously for 5s again

## 1.10 Timer function

- Timing range is 24 hours.
  - Timer on. The machine will turn on automatically when reaching the setting time.
  - Timer off. The machine will turn off automatically when reaching the setting time.
  - Timer on/off. The machine will turn on automatically when reaching the setting "on" time, and then turn off automatically when reaching the setting "off" time.
  - Timer off/on. The machine will turn off automatically when reaching the setting "off" time, and then turn on automatically when reaching the setting "on" time.
- The timer function will not change the AC current operation mode. Suppose AC is off now, it will not start up firstly after setting the "timer off" function. And when reaching the setting time, the timer LED will be off and the AC running mode has not been changed.
- The setting time is relative time.
- The AC will quit the timer function when it has malfunction.

## 1.11 Sleep function

- The sleep function is available in cooling, heating, or auto mode.
- The operational process for sleep mode is as follows:
  - When cooling, the temperature rises 1°C (less than 30°C) every hour. After 2 hours, the temperature stops rising and the indoor fan is fixed at low speed.
  - When heating, the temperature decreases 1°C (more than 17°C) every hour. After 2 hours, the temperature stops decreasing and the indoor fan is fixed at low speed. Anti-cold wind function takes priority.
- The operating time for sleep mode is 7 hours, after which, the unit exits this mode and switches off.
- The timer setting is available in this mode.

## 1.12 Auto-Restart function

- The indoor unit has an auto-restart module that allows the unit to restart automatically. The module

automatically stores the current settings (do not include the swing setting) , when meets power failure, air conditioner will restore those setting automatically within 3 minutes after power returns.

- If the unit was in forced cooling mode, it will run in this mode for 30 minutes and turn to auto mode with temperature set to 24°C.
- If there is a power failure while the unit is running, the compressor starts 3 minutes after the unit restarts. If the unit was already off before the power failure, the compressor starts 1 minute after the unit restarts.

### 1.13 Refrigerant Leakage Detection

With this new technology, the display area will show “EC” or “EL OC” when the outdoor unit detects refrigerant leakage. This function is only available in cooling mode.

### 1.14 Louver Position Memory Function

When starting the unit again after shutting down, its louver will restore to the angle originally set by the user, but the precondition is that the angle must be within the allowable range, if it exceeds, it will memorize the maximum angle of the louver. During operation, if the power fails or the end user shuts down the unit in the turbo mode, the louver will restore to the default angle.

### 1.15 8°C Heating(Optional)

In heating mode, the temperature can be set to as low as 8°C, preventing the indoor area from freezing if unoccupied during severe cold weather.

### 1.16 Self clean(Optional)

- If you press “Self Clean” when the unit is in cooling or drying mode:
  - For cooling models, the indoor unit will run in low fan mode for a certain time, then ceases operation.
  - For heat pump models, the indoor unit will run in fan-only mode, then low heat, and finally in fan-only mode.
- Self Clean keeps the indoor unit dry and prevents mold growth.

### 1.17 Follow me(Optional)

- If you press “Follow Me” on the remote, the indoor unit will beep. This indicates the follow me function is active.
- Once active, the remote control will send a signal every 3 minutes, with no beeps. The unit automatically sets the temperature according to the measurements from the remote control.

- The unit will only change modes if the information from the remote control makes it necessary, not from the unit’s temperature setting.
- If the unit does not receive a signal for 7 minutes or you press “Follow Me,” the function turns off. The unit regulates temperature based on its own sensor and settings.

### 1.18 Silence (Optional)

Press “Silence” on the remote control to enable the SILENCE function. While this function is active, the compressor frequency is maintained at a lower level than F3. The indoor unit will run at faint breeze, which reduces noise to the lowest possible level.

## 2. Remote Controller Functions

### 2.1 Infrared Wireless Remote Controller

#### 2.1.1. RG51F/E, RG51F1/E (Standard)

Remote Controller Specifications

Model	RG51F/E, RG51F1/E
Rated Voltage	3.0V (Dry batteries R03/LR03×2)
Reaching Distance	8m
Environment Temperature Range	-5°C~60°C(23°F~140°F)

Buttons and Functions

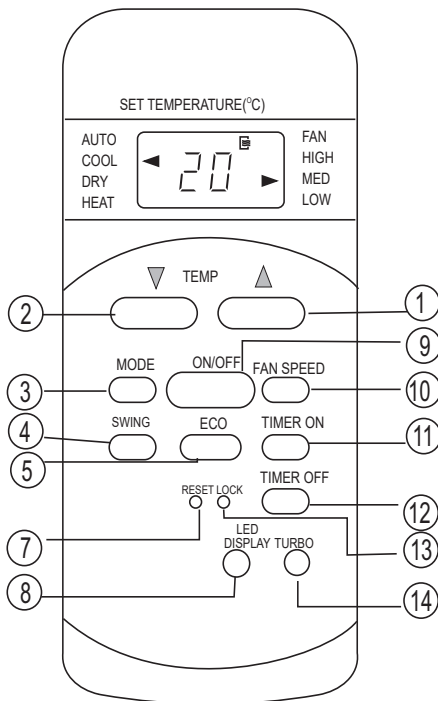

Model: RG51F/E

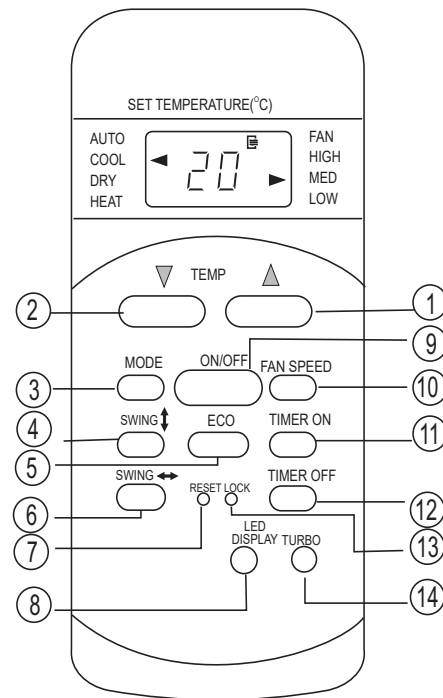

Model: RG51F1/E

1. TEMP UP ▲ Button: Push this button to increase the indoor temperature setting in 1°C increments to 30°C
2. TEMP DOWN ▼ Button: Push this button to decrease the indoor temperature setting in 1°C increments to 17°C.
3. MODE Button: Once pressing, running mode will be selected in the following sequence:

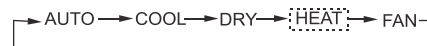

NOTE: No heating mode for cool only type unit.

4. SWING/SWING↕ Button: Used to stop or start horizontal louver movement or set the desired up/down air flow direction. The louver changes 6 degree in angle for each press. If keep pushing more than 2 seconds, the louver will swing up and down automatically.

5. ECO Button: Used to enter the energy efficient mode.

Under cooling mode, press this button, the remote controller will adjust the temperature automatically to 24°C, fan speed of Auto to save energy (but only if the set temperature is less than 24°C). If the set temperature is between 24°C and 30°C, press the ECO button, the fan speed will change to Auto, the set temperature will remain unchanged.

NOTE: Pressing the TURBO and SLEEP button, modifying the mode or adjusting the set temperature to less than 24°C will stop ECO operation.

Under ECO operation, the set temperature should be 24°C

---

or more. it may result in insufficient cooling. If you feel uncomfortable, just press the ECO button again to stop it.

6. SWING ↔ Button

Used to stop or start vertical louver movement and set the desired left/right air flow direction. The vertical louver changes 6 degree in angle for each press.

7. RESET Button (inner located): Once the recessed RESET button is pressed, all of the current settings will be cancelled and the controller will return to the initial settings.

8. LED DISPLAY Button: Disable/Active indoor screen Display. When pushing the button, the indoor screen display is cleared, press it again to light the display.

9. ON/OFF Button: Operation starts when this button is pressed and stops when the button is pressed again.

10. FAN SPEED Button: Fan speed will be selected in following sequence once pressing this button:

▶ AUTO → LOW → MED → HIGH ]

11. TIME ON Button: For time ON setting. Press this button to activate the Auto-on time setting. Each press will increase the time setting in 30 minutes increments, up to 10 hours, then at 1 hour increments up to 24 hours. To cancel the Auto-on time setting, just press the button until the time setting is 0.0.

12. TIME OFF Button: For time OFF setting. Press this button to activate the Auto-off time setting. Each press will increase the time setting in 30 minutes increments, up to 10 hours, then at 1 hour increments up to 24 hours. To cancel the Auto-off time setting, just press the button until the time setting is 0.0.

13. LOCK Button(inner located): When you press the recessed LOCK button, all current settings are locked in and the remote controller does not accept any operation except that of the LOCK. Press again to cancel the LOCK mode.

14. TURBO Button: Active/Disable Turbo function. Turbo function enables the unit to reach the preset temperature at cooling or heating operation in the shortest time(if the indoor unit does not support this function, there is no corresponding operation happened when pressing this button.)











---

# Installation

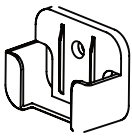
## Contents

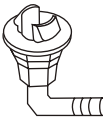
Accessories .....	46
1. Installation Overview .....	47
2. Location Selection .....	49
3. Indoor Unit Installation .....	50
4. Outdoor Unit Installation.....	55
5. Refrigerant Pipe Installation.....	57
6. Vacuum Drying and Leakage Checking.....	58
7. Additional Refrigerant Charge .....	59
8. Electrical and Gas Leak Checks .....	60
9. Test Operation .....	60

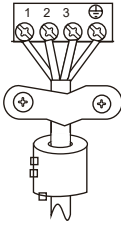
## Accessories

Name	Shape	Quantity	
Mounting plate		1	
Clip anchor		5~8(dependent on models)	
Mounting plate fixing screw ST3.9 X 25		5~8(dependent on models)	
Remote controller		1	
Fixing screw for remote controller holder ST2.9 x 10		2	Optional Parts
Remote controller holder		1	
Dry battery AAA.LR03		2	
Seal		1(for cooling & heating models only)	
Drain joint			
Manual		2~3	
Connecting pipe assembly	Liquid side	Φ6.35 (1/4in)	Parts you must purchase. Consult the dealer about the pipe size.
		Φ9.52 (3/8in)	
	Gas side	Φ9.52 (3/8in)	
		Φ12.7 (1/2in)	
		Φ16 (5/8in)	
		Φ19 (3/4in)	
Magnetic ring and belt(if supplied ,please refer to the wiring diagram ,please refer to the connective cable. )	  <p>Pass the belt through the hole of the Magnetic ring to fix it on the cable</p>	Varies by models	

# 1. Installation Overview-Indoor Unit

## Installation Order

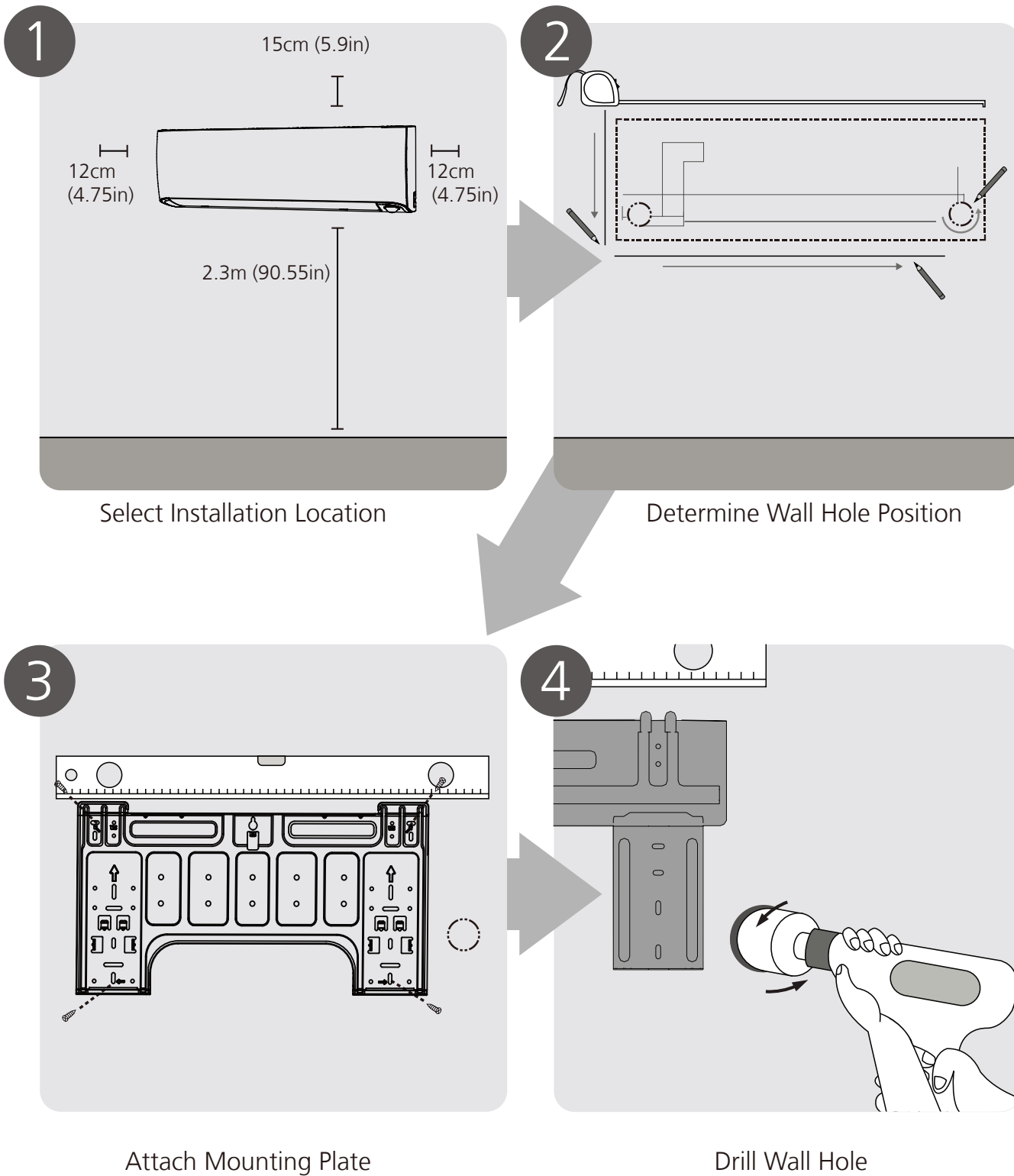

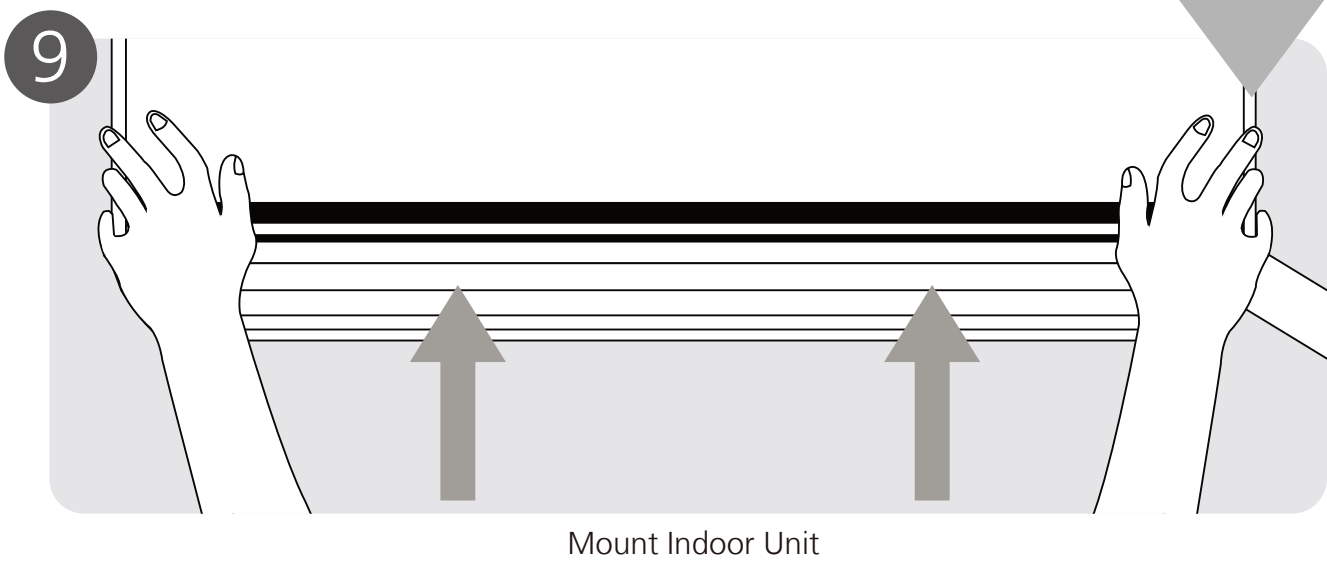
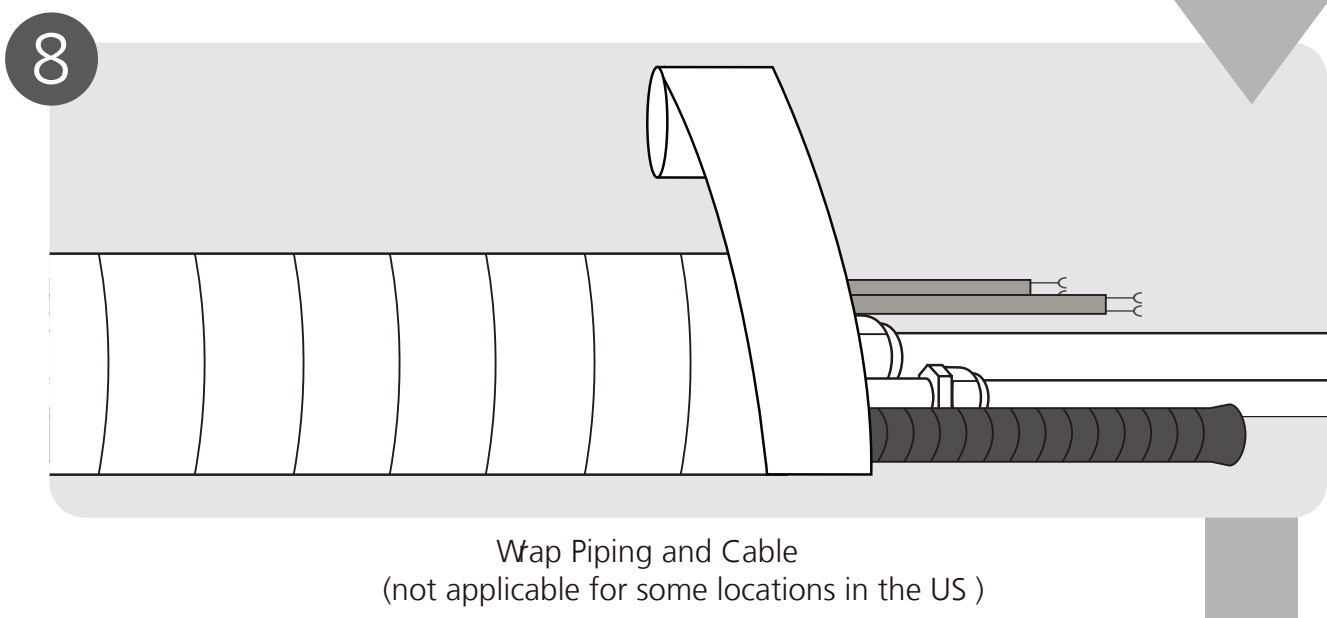
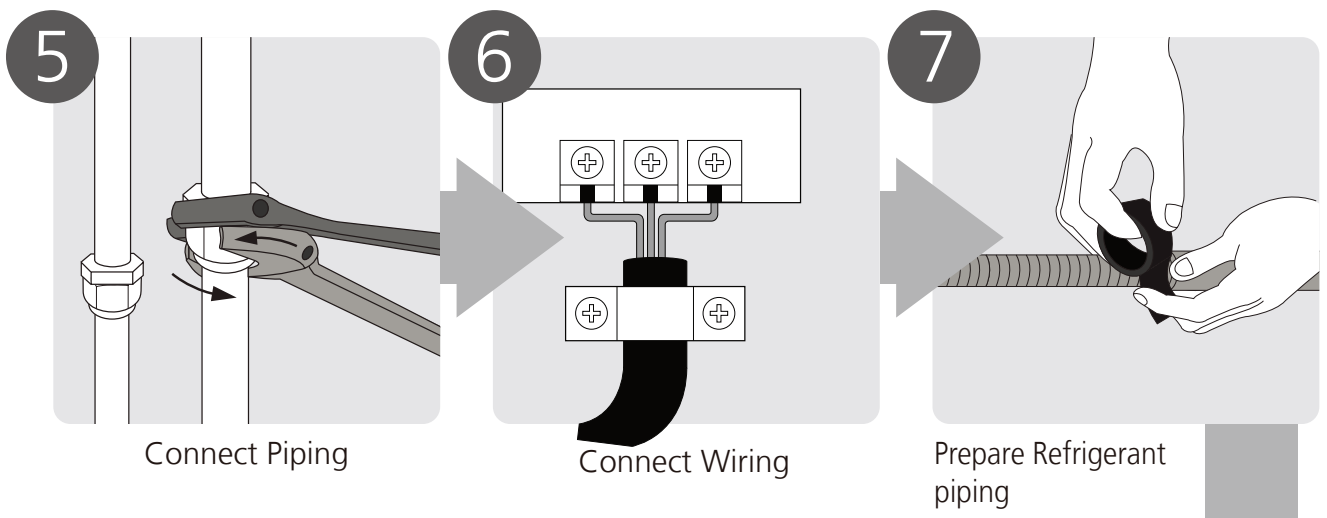

## 2. Location selection

2.1 Unit location selection can refer to installation manual.

2.2 **DO NOT** install the unit in the following locations:

- Where oil drilling or fracking is taking place.
- Coastal areas with high salt content in the air.
- Areas with caustic gases in the air, such as near hot springs.
- Areas with power fluctuations, such as factories.
- Enclosed spaces, such as cabinets.
- Areas with strong electromagnetic waves.
- Areas that store flammable materials or gas.
- Rooms with high humidity, such as bathrooms or laundry rooms.
- If possible, **DO NOT** install the unit where it is exposed to direct sunlight.

2.3 **The minimum distance between the outdoor unit and walls described in the installation guide does not apply to airtight rooms. Be sure to keep the unit unobstructed in at least two of the three directions (M, N, P)**

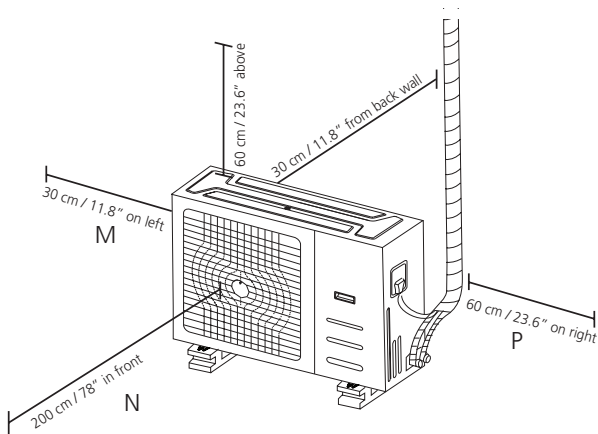

## 2.4 Rows of series installation

The relations between H, A and L are as follows.

	L	A
L ≤ H	$L \leq 1/2H$	25 cm / 9.8" or more
	$1/2H < L \leq H$	30 cm / 11.8" or more
L > H	Can not be installed	

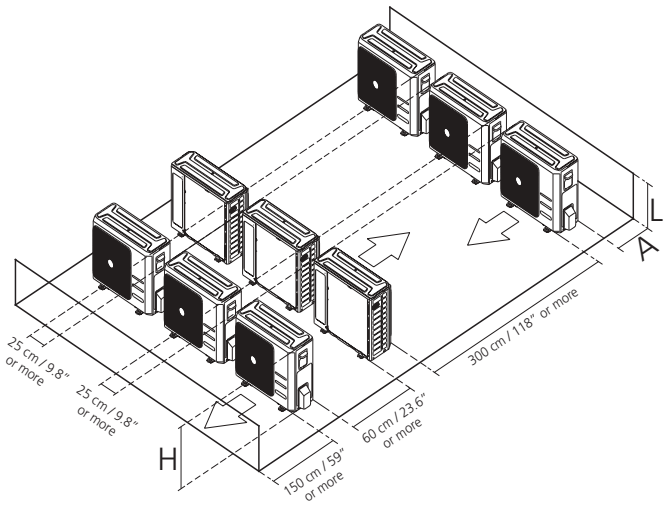

DO NOT install the rows of series like following figure.

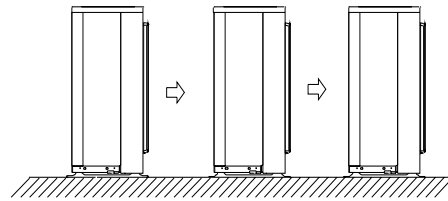

2.5 If the location is exposed to strong winds (for example: near a seaside), the unit must be placed against the wall to shelter it from the wind. If necessary, use an awning.

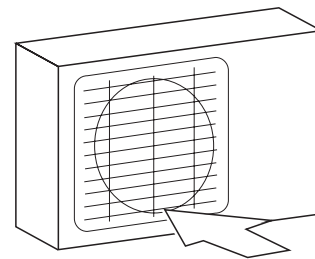

**DO NOT** Strong wind

## 3. Indoor Unit Installation

### 3.1 Service space for indoor unit

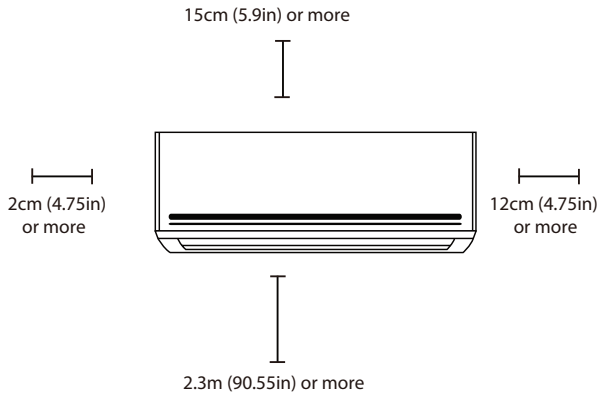

### 3.2 Attach mounting plate to wall

- **The mounting plate is the device on which you will mount the indoor unit.**

1. Remove the screw that attaches the mounting plate to the back of the indoor unit.
2. Place the mounting plate against the wall in a location that meets the standards in the Select Installation Location step. (See Mounting Plate Dimensions for detailed information on mounting plate sizes.)
3. Drill holes for mounting screws in places that:
  - have studs and can support the weight of the unit.
  - correspond to screw holes in the mounting plate.
4. Secure the mounting plate to the wall with the screws provided.
5. Make sure that mounting plate is flat against the wall.

- **Mounting plate dimensions**

Different models have different mounting plates. In order to ensure that you have ample room to mount the indoor unit, the diagrams to the right show different types of mounting plates along with the following dimensions:

1. Width of mounting plate
2. Height of mounting plate
3. Width of indoor unit relative to plate
4. Height of indoor unit relative to plate
5. Recommended position of wall hole (both to the left and right of mounting plate)
6. Relative distances between screw holes

Correct orientation of Mounting Plate

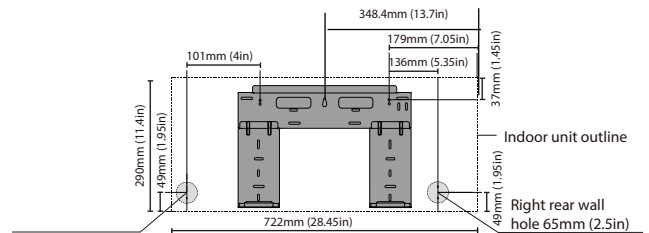
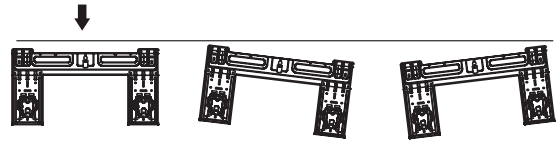

Model 20M/27M

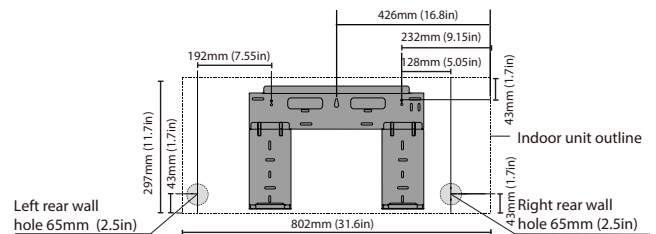

Model 35M

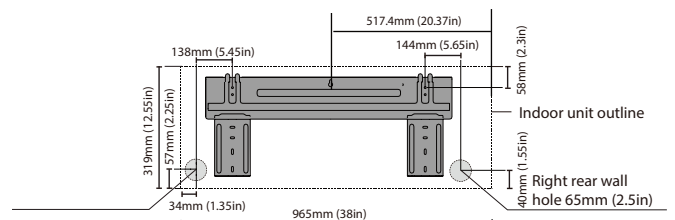

Model 53M

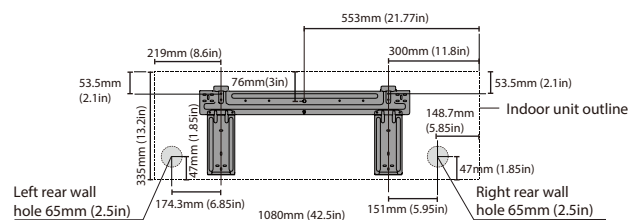

Model 70M

- **Note for concrete or brick walls:**

If the wall is made of brick, concrete, or similar material, drill 5mm-diameter (0.2in-diameter) holes in the wall and insert the sleeve anchors provided. Then secure the mounting plate to the wall by tightening the screws directly into the clip anchors.

### 3.3 Drill wall hole for connective piping

You must drill a hole in the wall for refrigerant piping, the drainage pipe, and the signal cable that will connect the indoor and outdoor units.

1. Determine the location of the wall hole based on the position of the mounting plate. Refer to Mounting Plate Dimensions on the next page to help you determine the optimal position. The wall hole should have a 65mm (2.5in) diameter at least, and at a slightly lower angle to facilitate drainage.
2. Using a 65mm (2.5in) or 90mm(3.54in) (depending on models )core drill, drill a hole in the wall. Make sure that the hole is drilled at a slight downward angle, so that the outdoor end of the hole is lower than the indoor end by about 5mm to 7mm (0.2-0.27in). This will ensure proper water drainage.
3. Place the protective wall cuff in the hole. This protects the edges of the hole and will help seal it when you finish the installation process.

**NOTE:** When drilling the wall hole, make sure to avoid wires, plumbing, and other sensitive components.

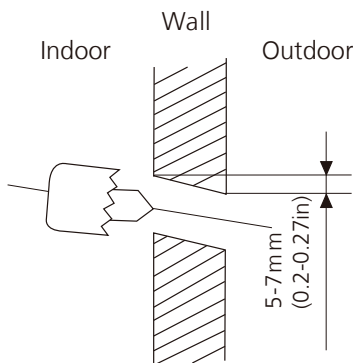

### 3.4 Prepare refrigerant piping

The refrigerant piping is inside an insulating sleeve attached to the back of the unit. You must prepare the piping before passing it through the hole in the wall. Refer to the Refrigerant Piping Connection section of this manual for detailed instructions on pipe flaring and flare torque requirements, technique, etc.

1. Based on the position of the wall hole relative to the mounting plate, choose the side from which the piping will exit the unit.
2. If the wall hole is behind the unit, keep the knock-out panel in place. If the wall hole is to the side of the indoor unit, remove the plastic knock-out panel from that side of the unit. This will create a slot through which your piping can exit the unit. Use needle nose pliers if the plastic panel is too difficult to remove by hand.

3. Groove has been made in the knock-out panel in order to cut it conveniently. The size of the slot is determined by the diameter of piping.

4. Use scissors to cut down the length of the insulating sleeve to reveal about 15cm (6in) of the refrigerant piping. This serves two purposes:

- To facilitate the Refrigerant Piping Connection process.
- To facilitate Gas Leak Checks and enable you to check for dents.

5. If existing connective piping is already embedded in the wall, proceed directly to the Connect Drain Hose step. If there is no embedded piping, connect the indoor unit's refrigerant piping to the connective piping that will join the indoor and outdoor units. Refer to the Refrigerant Piping Connection section of this manual for detailed instructions.

6. Based on the position of the wall hole relative to the mounting plate, determine the necessary angle of your piping.

7. Grip the refrigerant piping at the base of the bend.

8. Slowly, with even pressure, bend the piping towards the hole. Do not dent or damage the piping during the process.

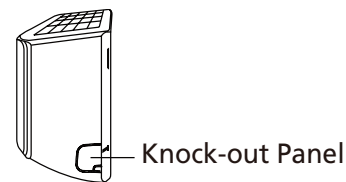

**NOTE:** Refrigerant piping can exit the indoor unit from four different angles:

- Left-hand side
- Left rear
- Right-hand side
- Right rear

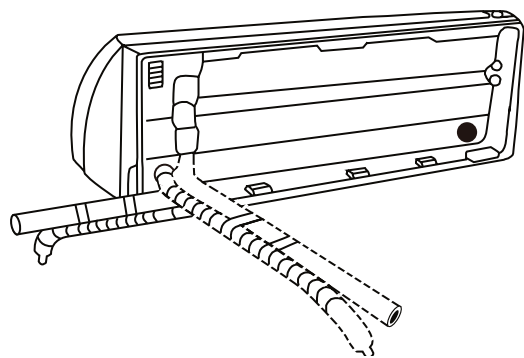

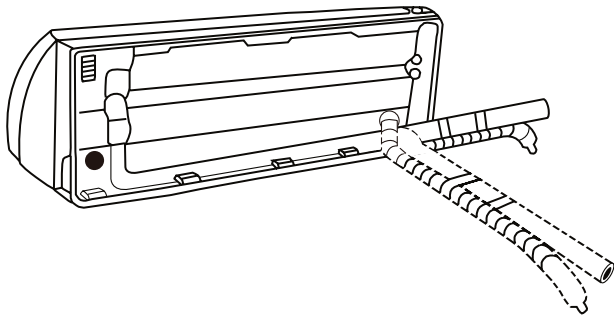

Be extremely careful not to dent or damage the piping while bending them away from the unit. Any dents in the piping will affect the unit's performance.

### 3.5 Connect drain hose

By default, the drain hose is attached to the left-hand side of unit (when you're facing the back of the unit). However, it can also be attached to the right-hand side. To ensure proper drainage, attach the drain hose on the same side that your refrigerant piping exits the unit. Attach drain hose extension (purchased separately) to the end of drain hose.

1. Wrap the connection point firmly with Teflon tape to ensure a good seal and to prevent leaks.
2. For the portion of the drain hose that will remain indoors, wrap it with foam pipe insulation to prevent condensation.
3. Remove the air filter and pour a small amount of water into the drain pan to make sure that water flows from the unit smoothly.

#### NOTE ON DRAIN HOSE PLACEMENT:

- DO NOT kink the drain hose.
- DO NOT create a water trap.
- DO NOT put the end of drain hose in water or a container that will collect water.

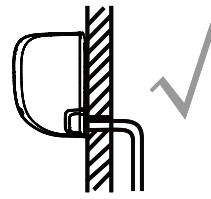

CORRECT

Make sure there are no kinks or dent in drain hose to ensure proper drainage.

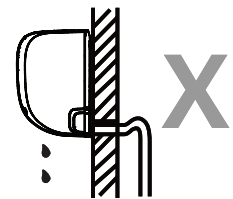

NOT CORRECT

Kinks in the drain hose will create water traps.

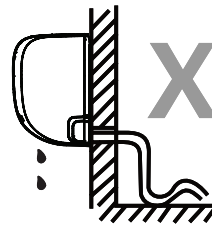

NOT CORRECT

Kinks in the drain hose will create water traps.

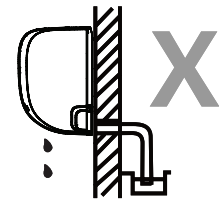

NOT CORRECT

Do not place the end of the drain hose in water or in containers that collect water. This will prevent proper drainage.

Make sure there are no kinks or dent in drain hose to ensure proper drainage.

## 3.6 Connect signal and power cable

### 3.6.1 Before performing electrical work, read these regulations

1. All wiring must comply with local and national electrical codes, and must be installed by a licensed electrician.
2. All electrical connections must be made according to the Electrical Connection Diagram located on the panels of the indoor and outdoor units.
3. If there is a serious safety issue with the power supply, stop work immediately. Explain your reasoning to the client, and refuse to install the unit until the safety issue is properly resolved.
4. Power voltage should be within 90-110% of rated voltage. Insufficient power supply can cause malfunction, electrical shock, or fire.
5. If connecting power to fixed wiring, install a surge protector and main power switch with a capacity of 1.5 times the maximum current of the unit.
6. If connecting power to fixed wiring, a switch or circuit breaker that disconnects all poles and has a contact separation of at least 1/8in (3mm) must be incorporated in the fixed wiring. The qualified technician must use an approved circuit breaker or switch.
7. Only connect the unit to an individual branch circuit outlet. Do not connect another appliance to that outlet.
8. Make sure to properly ground the air conditioner.
9. Every wire must be firmly connected. Loose wiring can cause the terminal to overheat, resulting in product malfunction and possible fire.
10. Do not let wires touch or rest against refrigerant tubing, the compressor, or any moving parts within the unit.
11. If the unit has an auxiliary electric heater, it must be installed at least 1 meter (40in) away from any combustible materials.

12. BEFORE PERFORMING ANY ELECTRICAL OR WIRING WORK, TURN OFF THE MAIN POWER TO THE SYSTEM.

### 3.6.2 Connect signal and power cable

The signal cable enables communication between the indoor and outdoor units. You must first choose the right cable size before preparing it for connection.

Cable Types:

- Indoor Power Cable (if applicable): H05VV-F or H05V2V2-F
- Outdoor Power Cable: H07RN-F

- Signal Cable: H07RN-F

Table: Minimum Cross-Sectional Area of Power and Signal Cables

Rated Current of Appliance (A)	Nominal Cross-Sectional Area (mm <sup>2</sup> )
> 3 and ≤ 6	0.75
> 6 and ≤ 10	1
> 10 and ≤ 16	1.5
> 16 and ≤ 25	2.5
> 25 and ≤ 32	4
> 32 and ≤ 40	6

1. Prepare the cable for connection:

- Using wire strippers, strip the rubber jacket from both ends of signal cable to reveal about 40mm (1.57in) of the wires inside.
- Strip the insulation from the ends of the wires.
- Using wire crimper, crimp u-type lugs on the ends of the wires.

2. Open front panel of the indoor unit.

3. Using a screwdriver, open the wire box cover on the right side of the unit. This will reveal the terminal block.

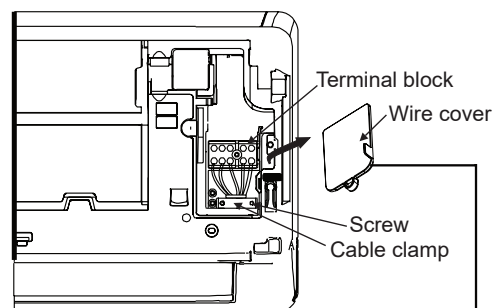

4. Unscrew the cable clamp below the terminal block and place it to the side.

5. Facing the back of the unit, remove the plastic panel on the bottom left-hand side.

6. Feed the signal wire through this slot, from the back of the unit to the front.

7. Facing the front of the unit, match the wire colors with the labels on the terminal block, connect the u-lug and firmly screw each wire to its corresponding terminal.

8. After checking to make sure every connection is secure,

use the cable clamp to fasten the signal cable to the unit. Screw the cable clamp down tightly.

9. Replace the wire cover on the front of the unit, and the plastic panel on the back.

#### NOTE:

- Choose the right cable size

The size of the power supply cable, signal cable, fuse, and switch needed is determined by the maximum current of the unit. The maximum current is indicated on the nameplate located on the side panel of the unit. Refer to this nameplate to choose the right cable, fuse, or switch.

- Take note of fuse specifications

The air conditioner's circuit board (PCB) is designed with a fuse to provide overcurrent protection. The specifications of the fuse are printed on the circuit board, such as: T3.15A/250VAC, T5A/250VAC, etc.

- Pay attention to live wire

While crimping wires, make sure you clearly distinguish the Live ("L") Wire from other wires.

- All wiring must be performed strictly in accordance with the wiring diagram located on the back of the indoor unit's front panel.
- Do not mix up live and null wires.

This is dangerous, and can cause the air conditioning unit to malfunction.

- The wiring connection process may differ slightly between units.

### 3.7 Wrap piping and cables

Before passing the piping, drain hose, and the signal cable through the wall hole, you must bundle them together to save space, protect them, and insulate them.

1. Bundle the drain hose, refrigerant pipes, and signal cable according to the picture below:

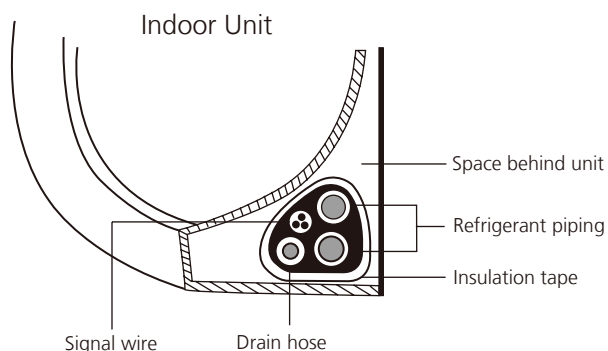

2. Using adhesive vinyl tape, attach the drain hose to the underside of the refrigerant pipes.

3. Using insulation tape, wrap the signal wire, refrigerant pipes, and drain hose tightly together. Double-check that all items are bundled in accordance with the picture above.

#### NOTE:

- Drain hose must be on bottom

Make sure that the drain hose is at the bottom of the bundle. Putting the drain hose at the top of the bundle can cause the drain pan to overflow, which can lead to fire or water damage.

- Do not intertwine signal cable with other wires

While bundling these items together, do not intertwine or cross the signal cable with any other wiring

- Do not wrap ends of piping

When wrapping the bundle, keep the ends of the piping unwrapped. You need to access them to test for leaks at the end of the installation process.

### 3.8 Mount indoor unit

#### 3.8.1 If you installed new connective piping to the outdoor unit, do the following:

1. If you have already passed the refrigerant piping through the hole in the wall, proceed to **Prepare refrigerant piping**.
2. Otherwise, double-check that the ends of the refrigerant pipes are sealed to prevent dirt or foreign materials from entering the pipes.
3. Slowly pass the wrapped bundle of refrigerant pipes, drain hose, and signal wire through the hole in the wall.
4. Hook the top of the indoor unit on the upper hook of the mounting plate.
5. Check that unit is hooked firmly on mounting by applying slight pressure to the left and right-hand sides of the unit. The unit should not jiggle or shift.
6. Using even pressure, push down on the bottom half of the unit. Keep pushing down until the unit snaps onto the hooks along the bottom of the mounting plate.
7. Again, check that the unit is firmly mounted by applying slight pressure to the left and the right-hand sides of the unit.

#### 3.8.2 If refrigerant piping is already embedded in the wall, do the following:

1. Hook the top of the indoor unit on the upper hook of the mounting plate.
2. Use the holder in the mounting plate to prop up the unit, giving you enough room to connect the refrigerant

piping, signal cable, and drain hose.

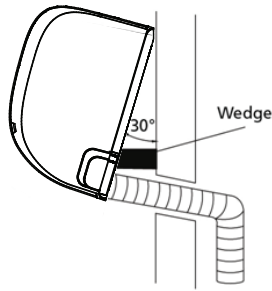

3. Connect drain hose and refrigerant piping (refer to Refrigerant Piping Connection section of this manual for instructions).

4. Keep pipe connection point exposed to perform the leak test (refer to Electrical Checks and Leak Checks section of this manual).

5. After the leak test, wrap the connection point with insulation tape.

6. Remove the bracket or wedge that is propping up the unit.

7. Using even pressure, push down on the bottom half of the unit. Keep pushing down until the unit snaps onto the hooks along the bottom of the mounting plate.

**NOTE:**

- Unit is adjustable

Keep in mind that the hooks on the mounting plate are smaller than the holes on the back of the unit. If you find that you don't have ample room to connect embedded pipes to the indoor unit, the unit can be adjusted left or right by about 30-50mm (1.25-1.95in), depending on the model.

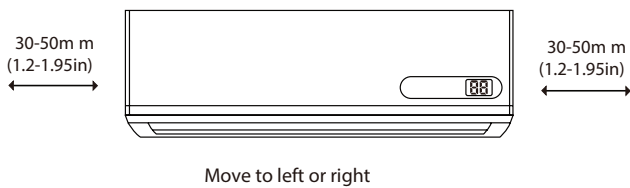

## 4. Outdoor unit installation(Side Discharge Unit)

### 4.1 Service space for outdoor unit

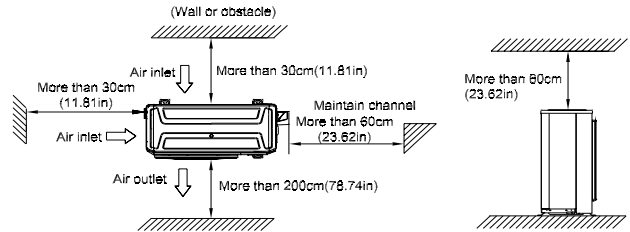

### 4.2 Bolt pitch

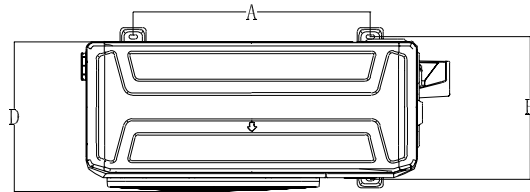

Size	unit	D	A	B
27M / 35M	mm	270	452	255
	inch	10.63	17.80	10.04
53M	mm	330	511	317
	inch	13	20.1	12.5
70M	mm	342	663	354
	inch	13.5	26.1	13.9

Installation

### 4.3 Install Outdoor Unit

Fix the outdoor unit with anchor bolts(M10)

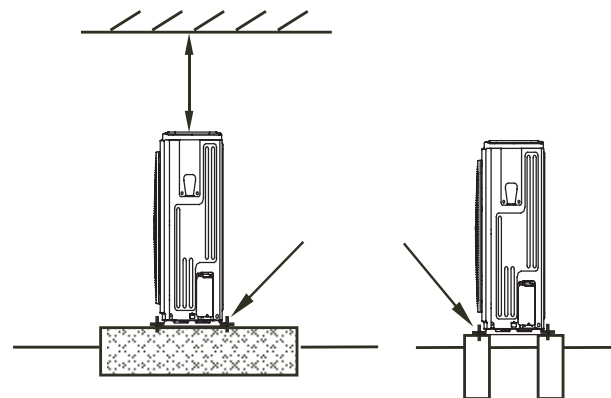

**Caution**

Since the gravity center of the unit is not at its physical center, so please be careful when lifting it with a sling.

Never hold the inlet of the outdoor unit to prevent it from deforming.

Do not touch the fan with hands or other objects.

Do not lean it more than 45°, and do not lay it sidelong.

Make concrete foundation according to the specifications of the outdoor units.

Fasten the feet of this unit with bolts firmly to prevent it from collapsing in case of earthquake or strong wind.

#### 4.4 Install drain joint

Heat pump units require a drain joint. Before bolting the outdoor unit in place, you must install the drain joint at the bottom of the unit. Note that there are two different types of drain joints depending on the type of outdoor unit.

- **If the drain joint comes with a rubber seal (see Fig. A ), do the following:**

1. Fit the rubber seal on the end of the drain joint that will connect to the outdoor unit.
2. Insert the drain joint into the hole in the base pan of the unit.
3. Rotate the drain joint 90° until it clicks in place facing the front of the unit.
4. Connect a drain hose extension (not included) to the drain joint to redirect water from the unit during heating mode.

- **If the drain joint doesn't come with a rubber seal (see Fig. B ), do the following:**

1. Insert the drain joint into the hole in the base pan of the unit. The drain joint will click in place.
2. Connect a drain hose extension (not included) to the drain joint to redirect water from the unit during heating mode.

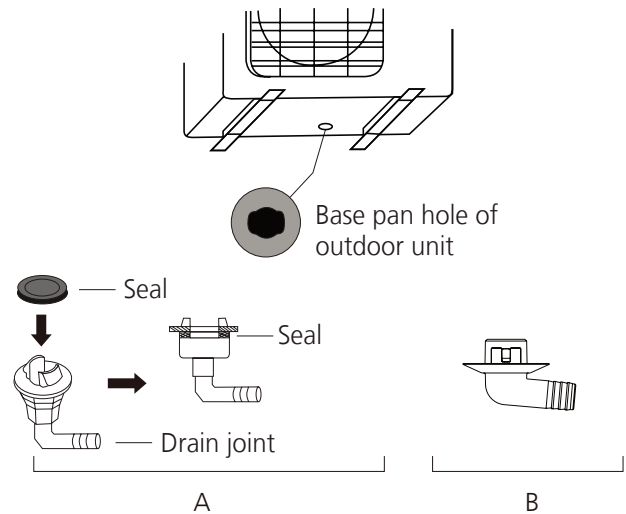

## 5. Refrigerant Pipe Installation

### 5.1 Maximum length and drop height

Ensure that the length of the refrigerant pipe, the number of bends, and the drop height between the indoor and outdoor units meets the requirements shown in the following table.

Size	Max. Length (m/ft)	Max. Elevation (m/ft)
27M / 35M	25/82	10/33
53M / 70M	30/98	20/66

#### caution:

- The capacity test is based on the standard length and the maximum permissible length is based on the system reliability.
- Oil traps

If the indoor unit is installed higher than the outdoor unit:

-If oil flows back into the outdoor unit's compressor, this might cause liquid compression or deterioration of oil return. Oil traps in the rising gas piping can prevent this.

An oil trap should be installed every 10m(32.8ft) of vertical suction line riser.

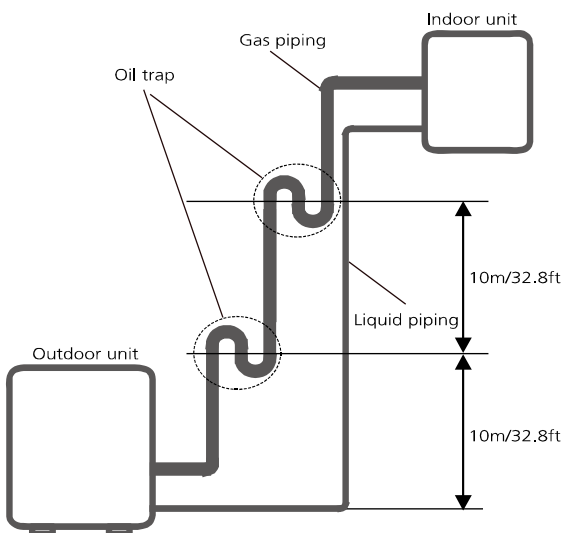

The indoor unit is installed higher than the outdoor unit

If the outdoor unit is installed higher than the indoor unit:

-It is recommended that vertical suction risers not be upsized. Proper oil return to the compressor should be maintained with suction gas velocity. If velocities drop below 7.62m/s(1500fpm (feet per minute)), oil return will be decreased. An oil trap should be installed every 6m(20ft) of vertical suction line riser.

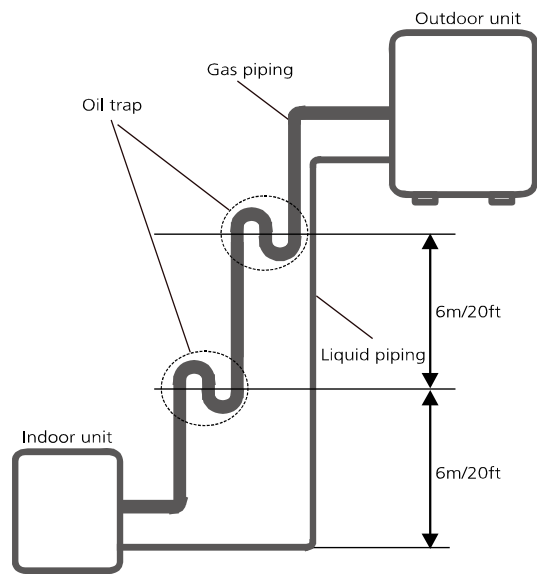

The outdoor unit is installed higher than the indoor unit.

### 5.2 The procedure of connecting pipes

1. Choose the pipe size according to the specification table.
2. Confirm the cross way of the pipes.
3. Measure the necessary pipe length.
4. Cut the selected pipe with pipe cutter
  - Make the section flat and smooth.

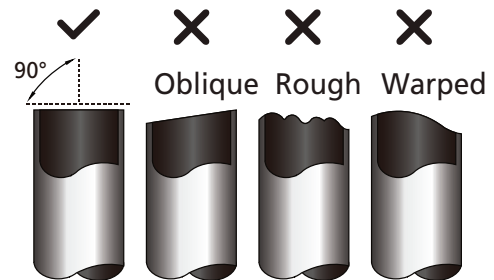

5. Insulate the copper pipe
  - Before test operation, the joint parts should not be heat insulated.
6. Flare the pipe
  - Insert a flare nut into the pipe before flaring the pipe
  - According to the following table to flare the pipe.

Outer diameter of pipe (inch(mm))	A (mm/inch)	
	Min	Max
1/4" (6.35)	0.7/0.0275	1.3/0.05
3/8" (9.52)	1.0/0.04	1.6/0.063
1/2" (12.7)	1.0/0.04	1.8/0.07
5/8" (15.9)	2.0/0.078	2.2/0.086
3/4" (19)	2.0/0.078	2.4/0.094

- After flared the pipe, the opening part must be seal by end cover or adhesive tape to avoid duct or exogenous impurity come into the pipe.
- Drill holes if the pipes need to pass the wall.
  - According to the field condition to bend the pipes so that it can pass the wall smoothly.
  - Bind and wrap the wire together with the insulated pipe if necessary.
  - Set the wall conduit
  - Set the supporter for the pipe.
  - Locate the pipe and fix it by supporter
    - For horizontal refrigerant pipe, the distance between supporters should not be exceed 1m.
    - For vertical refrigerant pipe, the distance between supporters should not be exceed 1.5m.
  - Connect the pipe to indoor unit and outdoor unit by using two spanners.
    - Be sure to use two spanners and proper torque to fasten the nut, too large torque will damage the bellmouthing, and too small torque may cause leakage. Refer the following table for different pipe connection.

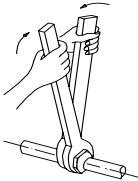
Pipe Diameter	Torque	Sketch map
	N.m(lb.ft)	
1/4" (6.35)	15~16 (11~11.8)	
3/8" (9.52)	25~26 (18.4~19.18)	
1/2" (12.7)	35~36 (25.8~26.55)	
5/8" (15.9)	45~47 (33.19~34.67)	
3/4" (19)	65~67 (47.94~49.42)	

## 6. Vacuum Drying and Leakage Checking

### 6.1 Purpose of vacuum drying

- Eliminating moisture in system to prevent the phenomena of ice-blockage and copper oxidation. Ice-blockage shall cause abnormal operation of system, while copper oxide shall damage compressor.
- Eliminating the non-condensable gas (air) in system to prevent the components oxidizing, pressure fluctuation and bad heat exchange during the operation of system.

### 6.2 Selection of vacuum pump

- The ultimate vacuum degree of vacuum pump shall be -756mmHg or above.
- Precision of vacuum pump shall reach 0.02mmHg or above.

### 6.3 Operation procedure for vacuum drying

Due to different construction environment, two kinds of vacuum drying ways could be chosen, namely ordinary vacuum drying and special vacuum drying.

#### 6.3.1 Ordinary vacuum drying

- When conduct first vacuum drying, connect pressure gauge to the infusing mouth of gas pipe and liquid pipe, and keep vacuum pump running for 1 hour (vacuum degree of vacuum pump shall be reached -755mmHg).
- If the vacuum degree of vacuum pump could not reach -755mmHg after 1 hour of drying, it indicates that there is moisture or leakage in pipeline system and need to go on with drying for half an hour.
- If the vacuum degree of vacuum pump still could not reach -755mmHg after 1.5 hours of drying, check whether there is leakage source.
- Leakage test: After the vacuum degree reaches -755mmHg, stop vacuum drying and keep the pressure for 1 hour. If the indicator of vacuum gauge does not go up, it is qualified. If going up, it indicates that there is moisture or leak source.

#### 6.3.2 Special vacuum drying

The special vacuum drying method shall be adopted when:

- Finding moisture during flushing refrigerant pipe.
- Conducting construction on rainy day, because rain

water might penetrated into pipeline.

3. Construction period is long, and rain water might penetrated into pipeline.

4. Rain water might penetrate into pipeline during construction.

Procedures of special vacuum drying are as follows:

1. Vacuum drying for 1 hour.

2. Vacuum damage, filling nitrogen to reach 0.5Kgf/cm<sup>2</sup> .

Because nitrogen is dry gas, vacuum damage could achieve the effect of vacuum drying, but this method could not achieve drying thoroughly when there is too much moisture. Therefore, special attention shall be drawn to prevent the entering of water and the formation of condensate water.

3. Vacuum drying again for half an hour.

If the pressure reached -755mmHg, start to pressure leakage test. If it cannot reached the value, repeat vacuum damage and vacuum drying again for 1 hour.

4. Leakage test: After the vacuum degree reaches -755mmHg, stop vacuum drying and keep the pressure for 1 hour. If the indicator of vacuum gauge does not go up, it is qualified. If going up, it indicates that there is moisture or leak source.

## 7. Additional Refrigerant Charge

- After the vacuum drying process is carried out, the additional refrigerant charge process need to be performed.
- The outdoor unit is factory charged with refrigerant. The additional refrigerant charge volume is decided by the diameter and length of the liquid pipe between indoor and outdoor unit. Refer the following formula to calculate the charge volume.

Diameter of liquid pipe (mm)	Formula
6.35	$V=12g/m \times (L-5)$
9.52	$V=24g/m \times (L-5)$

**V:** Additional refrigerant charge volume (g).

**L :** The length of the liquid pipe (m).

Note:

- Refrigerant may only be charged after performed the vacuum drying process.
- Always use gloves and glasses to protect your hands and eyes during the charge work.
- Use electronic scale or fluid infusion apparatus to weight refrigerant to be recharged. Be sure to avoid extra refrigerant charged, it may cause liquid hammer of the compressor or protections.
- Use supplementing flexible pipe to connect refrigerant cylinder, pressure gauge and outdoor unit. And The refrigerant should be charged in liquid state. Before recharging, The air in the flexible pipe and manifold gauge should be exhausted.
- After finished refrigerant recharge process, check whether there is refrigerant leakage at the connection joint part.(Using gas leakage detector or soap water to detect).

## 8. Electrical and Gas Leak Checks

### 8.1 Electrical Safety Checks

After installation, confirm that all electrical wiring is installed in accordance with local and national regulations, and according to the Installation Manual.

#### 8.1.1 Before test run

- **Check Grounding Work**

Measure grounding resistance by visual detection and with grounding resistance tester. Grounding resistance must be less than 0.1  $\Omega$ .

**Note:** This may not be required for some locations in the US.

#### 8.1.2 During test run

- **Check for Electrical Leakage**

During the Test Run, use an electroprobe and multimeter to perform a comprehensive electrical leakage test.

If electrical leakage is detected, turn off the unit immediately and call a licensed electrician to find and resolve the cause of the leakage.

**Note:** This may not be required for some locations in the US.

### 8.2 Gas Leak Checks

There are two different methods to check for gas leaks.

- **Soap and Water Method**

Using a soft brush, apply soapy water or liquid detergent to all pipe connection points on the indoor unit and outdoor unit. The presence of bubbles indicates a leak.

- **Leak Detector Method**

If using leak detector, refer to the device's operation manual for proper usage instructions.

### 8.3 After performing gas leak checks

After confirming that the all pipe connection points DO NOT leak, replace the valve cover on the outside unit.

## 9. Test Operation

### 9.1 Before test run:

Only perform test run after you have completed the following steps:

- Electrical Safety Checks – Confirm that the unit's electrical system is safe and operating properly
- Gas Leak Checks – Check all flare nut connections and confirm that the system is not leaking
- Confirm that gas and liquid (high and low pressure) valves are fully open

### 9.2 Test Run Instructions

You should perform the Test Run for at least 30 minutes.

1. Connect power to the unit.
2. Press the ON/OFF button on the remote controller to turn it on.
3. Press the MODE button to scroll through the following functions, one at a time:
  - COOL – Select lowest possible temperature
  - HEAT – Select highest possible temperature
4. Let each function run for 5 minutes, and perform the following checks:

List of Checks to Perform	PASS/FALL	
No electrical leakage		
Unit is properly grounded		
All electrical terminals properly covered		
Indoor and outdoor units are solidly installed		
All pipe connection points do not leak	Outdoor(2)	Outdoor(2)
Water drains properly from drain hose		
All piping is properly insulated		
Unit performs COOL function properly		
Unit performs HEAT function properly		
Indoor unit louvers rotate properly		
Indoor unit responds to remote controller		

---

5. After the Test Run is successfully completed, and you confirm that all checks points in List of Checks to Perform have PASSED, do the following:

- Using remote control, return unit to normal operating temperature.
- Using insulation tape, wrap the indoor refrigerant pipe connections that you left uncovered during the indoor unit installation process.

### 9.3 If ambient temperature is below 17°C (62°F)

You can't use the remote controller to turn on the COOL function when the ambient temperature is below 17°C. In this instance, you can use the MANUAL CONTROL button to test the COOL function.

1. Lift the front panel of the indoor unit, and raise it until it clicks in place.
2. The MANUAL CONTROL button is located on the right-hand side of the display box. Press it two times to select the COOL function.
3. Perform Test Run as normal.

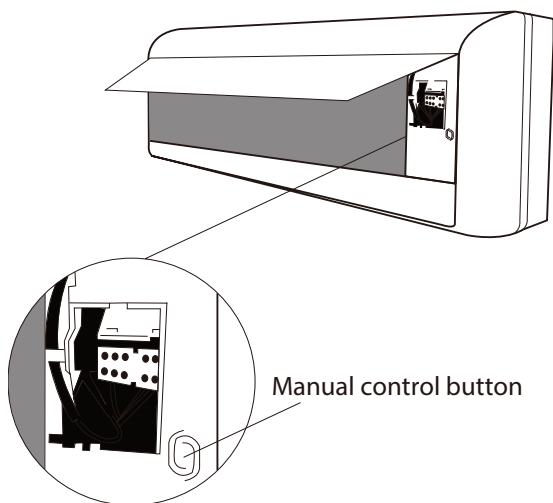







**MideaGroup**  
*humanizing technology*

**CLIVET S.p.A.**

Via Camp Lonc 25, Z.I. Villapaiera  
32032 Feltre (BL) - Italy  
Tel. +39 0439 3131 - info@clivet.it

**CLIVET GMBH**

Hummelsbütteler Steindamm 84,  
22851 Norderstedt, Germany  
Tel. +49 40 325957-0 - info.de@clivet.com

**Clivet Group UK LTD**

Units F5 & F6 Railway Triangle,  
Portsmouth, Hampshire PO6 1TG  
Tel. +44 02392 381235 -  
Enquiries@Clivetgroup.co.uk

**CLIVET LLC**

Office 508-511, Elektrozavodskaya st. 24,  
Moscow, Russian Federation, 107023  
Tel. +7495 6462009 - info.ru@clivet.com

**CLIVET MIDEAST FZCO**

Dubai Silicon Oasis (DSO), High Bay Complex,  
Office N. 20, PO BOX 342009, Dubai, UAE  
Tel. +9714 3208499 - info@clivet.ae

**Clivet South East Europe**

Jarušćica 9b  
10000, Zagreb, Croatia  
Tel. +385916065691 - info.see@clivet.com

**Clivet Airconditioning Systems Pvt Ltd**

Office No.501 & 502,5th Floor, Commercial -I,  
Kohinoor City, Old Premier Compound, Off  
LBS Marg, Kirool Road, Kurla West, Mumbai  
Maharashtra 400070, India  
Tel. +91 22 30930200 - sales.india@clivet.com