

*Cased and uncased water terminal unit*

# AURA

## CFF - CFFA 1-12 RANGE

TECHNICAL BULLETIN



SIZE	1	2	3	4	5	6	8	9	10	12
COOLING CAPACITY DC KW	1,50	1,95	2,35	2,85	3,50	3,90	4,85	5,60	6,35	8,25
COOLING CAPACITY AC KW	1,65	2,25	2,65	3,05	3,85	4,20	5,35	6,00	6,75	8,25

## Page

---

Features and benefits	3
Standard unit technical specifications	8
Accessories separately supplied	9
General technical data	13
Dimensions	26



Clivet participates in the ECP Programme for "Liquid Chillers and Hydronic Heat Pumps".  
Check ongoing validity of certificate on [www.eurovent-certification.com](http://www.eurovent-certification.com)"

# Features and benefits

AURA is the fan-coil for floor or ceiling installation for extreme comfort with an innovative design, in line with the standards of modern European environments, thanks to a meticulous study of the lines and materials.



CFFC - CFFAC  
cased

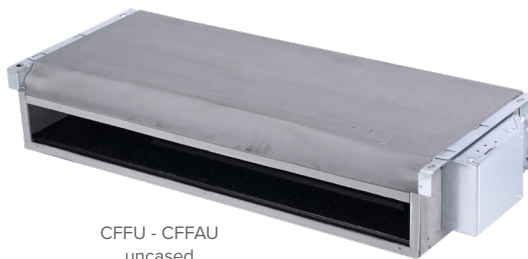

CFFU - CFFAU  
uncased

## Application flexibility

Thanks to the numerous configurations available, AURA flexibly and effectively is able to fulfill different application requirements. The fan coil is available in 2 and 4 pipes version. The unit can be selected with casing for exposed applications or uncased for built-in installation, and it is possible to install it vertically or horizontally. Air intake is available from the bottom of the unit (rear in case of horizontal installation) or from the front (bottom in case of horizontal installation, only for cased models).



To add further ease during the installation phase, AURA presents the installer with the possibility of moving the water pipes to the right side of the unit even on site, simply by removing the heat exchange coil and turning it over. Consequently, the control panel on the unit can be moved from one side to the other as well.

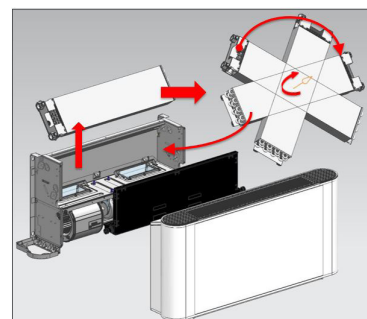

## Reduced consumptions

The exclusive electric DC motor of AURA's (CFFC - CFFU models) fan ensures reduced consumption as the ventilation can be modulated.

The high efficiency levels of its innovative technological solution noticeably limits the energy required to operate it correctly, thereby reducing the power used and running costs compared with traditional fan-coils.

Compared with a traditional fan-coil, it is possible to achieve savings of about 40% in terms of electricity and 60% in terms of absolute power.

## Silent

Thanks to the use of modulating fans and a careful study of the internal components, AURA is one of the best units on the market for silent operation.

When the fan is operating at minimum speed, AURA reaches a sound pressure of only 20 dB(A)\*

\*For the CFFC 3 version at minimum speed. The sound pressure level refers to a distance of 1m from the surface of the unit operating in an open field.

## Gestione velocità ventilatore da segnale esterno

La predisposizione al comando della velocità del ventilatore da segnale esterno 0-10V è disponibile di standard per i modelli con motore DC.

La gestione da segnale esterno preclude la gestione dell'unità e relativi accessori attraverso i controlli standard e opzionali. In particolare, in questa modalità, le funzioni Auto-Restart, e anti-aria fredda non sono disponibili.

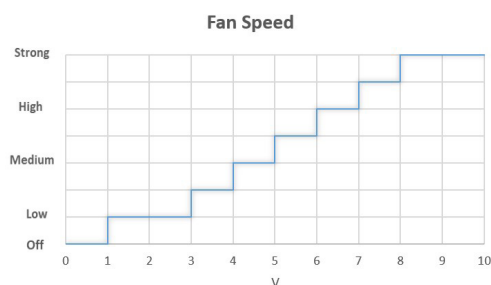

## A single terminal for all seasons

With a single terminal it is possible to heat up in winter, while in summer it allows you to cool down and dehumidify rooms. AURA guarantees well-being all year round because it reaches the desired temperature quickly and does not take long to heat up the rooms.



## Functions and usability - DC Inverter AURA models: CFFC - CFFU

In the DC version, AURA fan coil is compatible with the optional KJRP-75 user interface.



The controller is supplied installed on board (for cased versions) or supplied separately for application in a remote position on the wall.

The interface has a touch screen, backlight and 7-step + AUTO ventilation speed control.

The interface also has a temperature sensor, the room temperature reading can be moved from the unit's return channel to the interface itself with the Follow-me function.

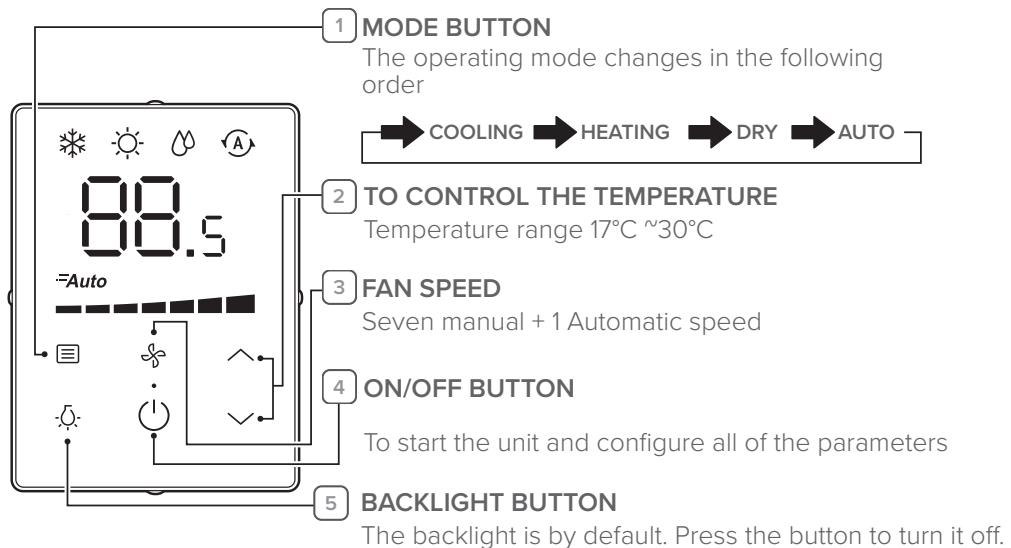
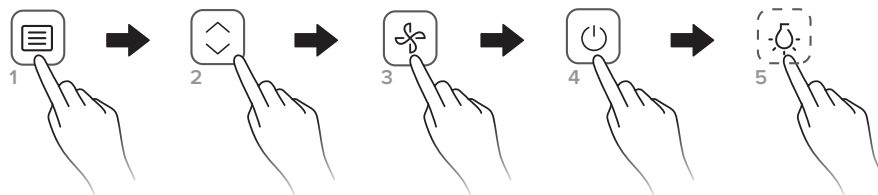

# Features and benefits

## Functions and usability - AURA AC models: CFFAC - CFFAU

In the AC version, the AURA fan coil is compatible with the optional KJRP-86R user interface.



KJRP-86R

The controller is supplied installed on board (for cased versions) or supplied separately for application in a remote position on the wall. The interface has a touch screen, backlight and 3-step + AUTO ventilation speed control.

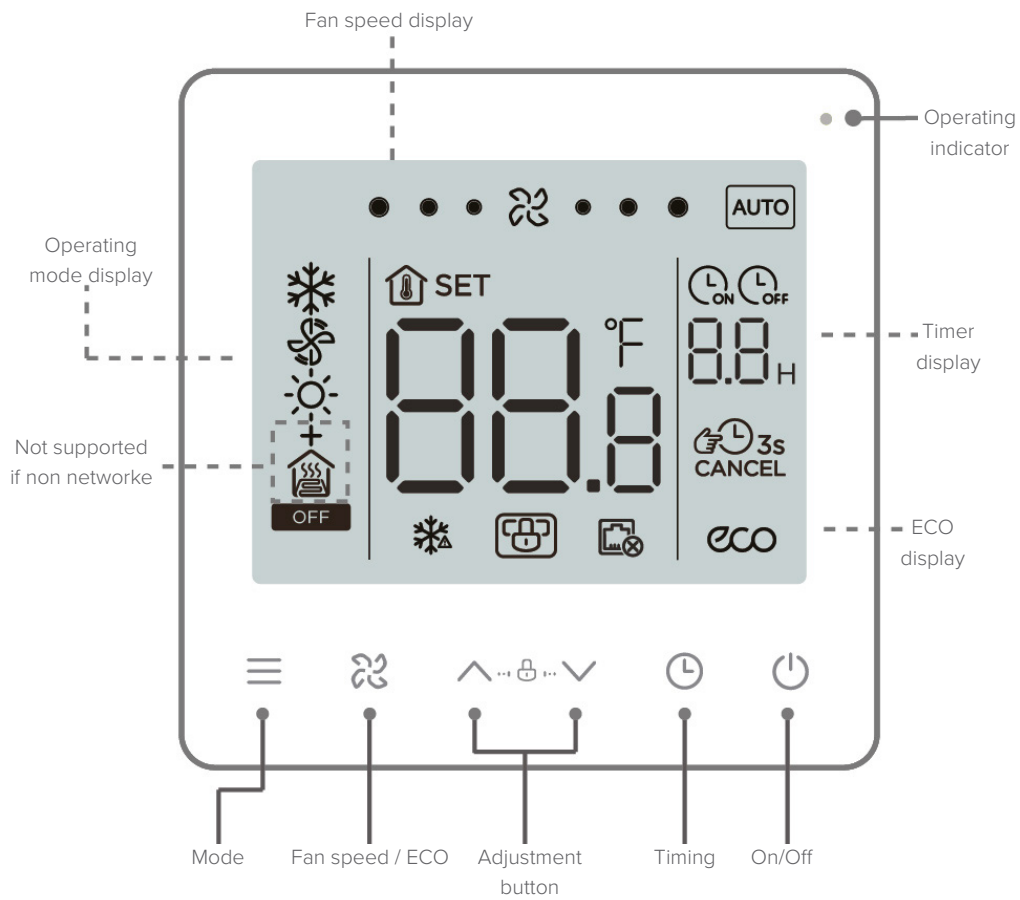

## Connectivity

AURA, in the DC inverter models CFFC and CFFU, is compatible with ELFOControl<sup>3</sup> EVO, the centralised management system designed for 360° control of Clivet systems.

Furthermore, the unit has a Modbus port for control via an external home automation system, as well as an input for on/off potential-free contact and a 0-10V input for adjusting the ventilation speed.

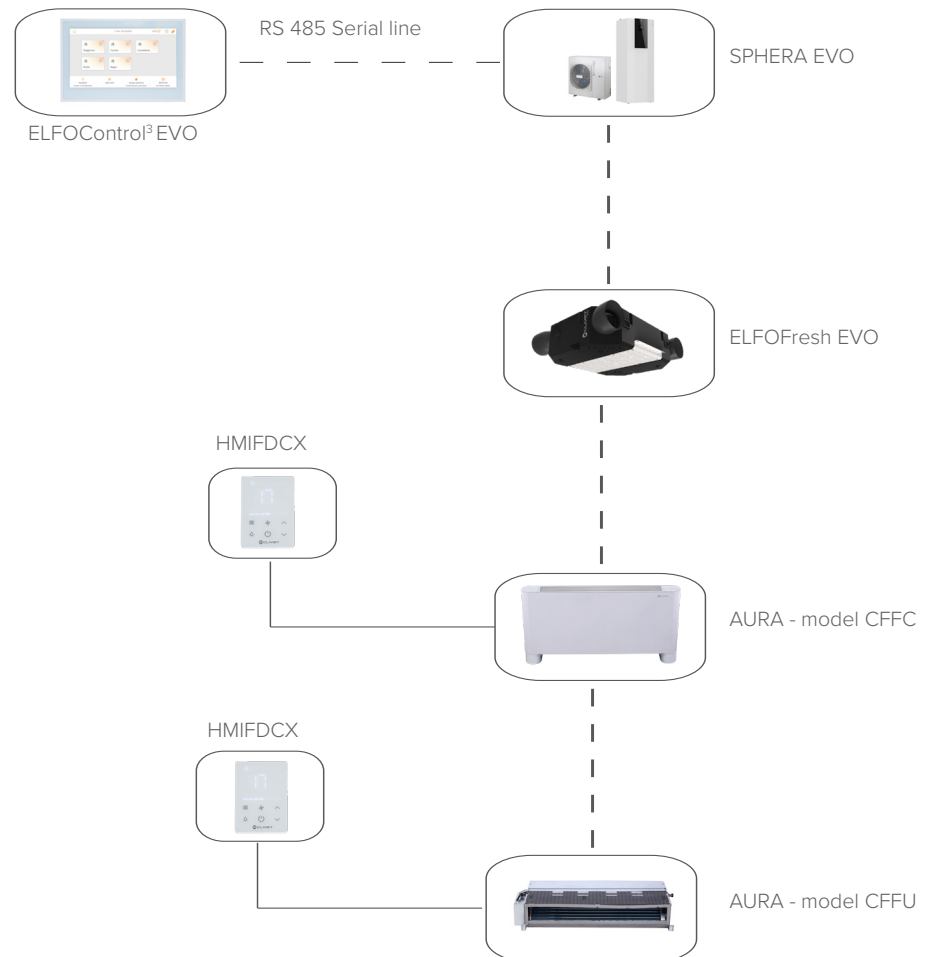

# Features and benefits

## Connectivity

The AC version of AURA (CFFAC and CFFAU) can be integrated with ELFOControl<sup>3</sup> EVO and third party supplied BMS as well, thanks to the Modbus port present on the optional controls.

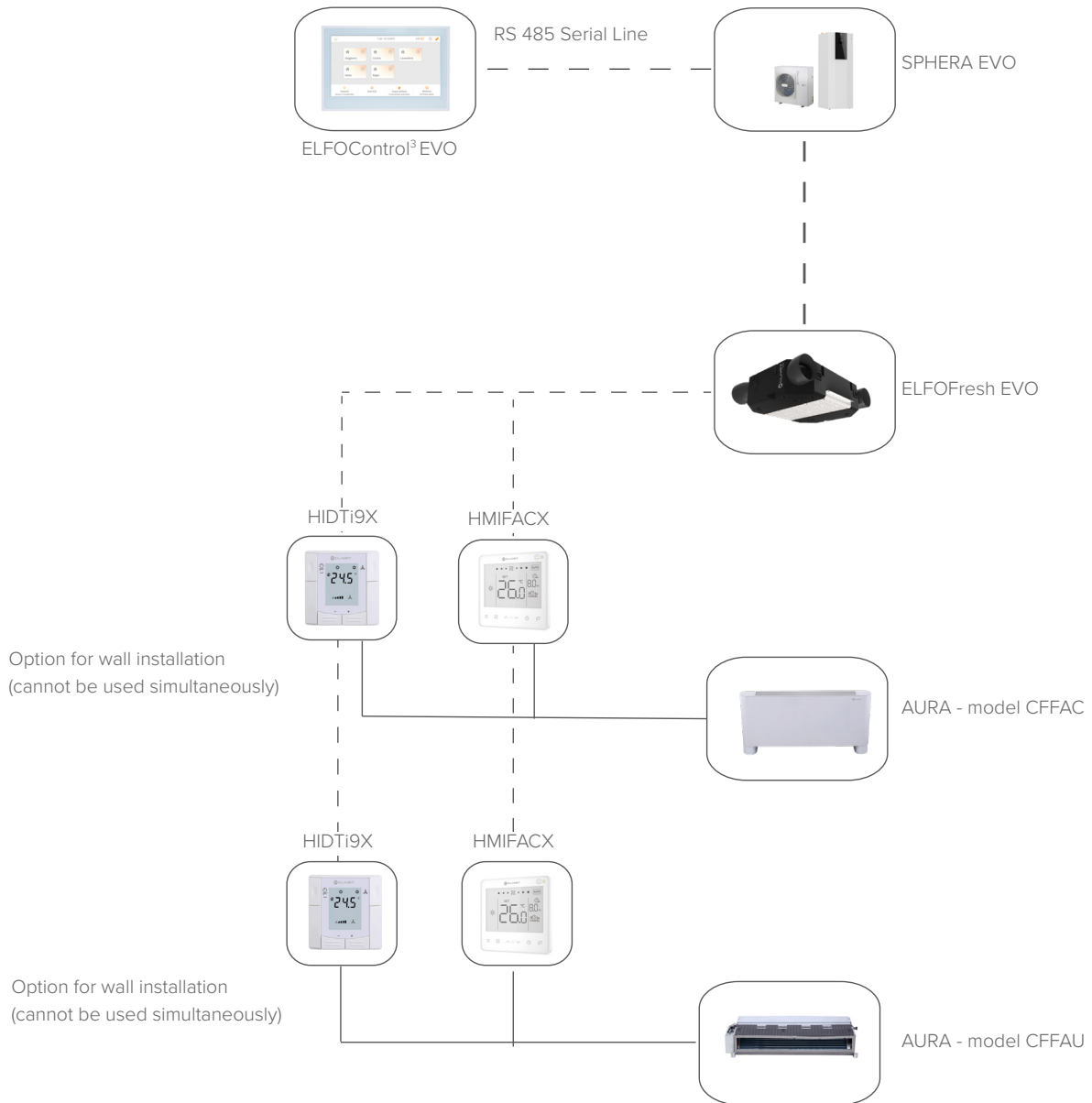

# Standard unit technical specifications

## Structure

The unit is made of galvanised steel with thermal insulation foam inside and an anti-condensation barrier on the outer casing.

## Internal exchanger

It consists of copper pipes and aluminium fins, with hydrophilic coating, fixed to the pipes with mechanical expansion process and shaped accordingly. 2 and 4 pipes models have coils with 3 or 4 rows. The exchanger is not suitable for use in corrosive atmospheres or in environments where aluminium may corrode.

## Fan

The motor-fan unit, hanging on antivibration mounts, is particularly silent. Modulating DC Inverter electric motor (CFFC - CFFU models), or 3 speed motor AC (CFFAC - CFFAU models).

## Filtration

Washable renewable synthetic filter, G2/ISO Coarse, easily accessible.

## Condensate drain

The unit is standard supplied with an L-shaped drain tray to ensure that condensate can be drained when the unit is installed horizontally or vertically.

## Electrical panel

Electrical panel inside the unit on the right for full and easy accessibility. The wired controller supplied as standard can be installed either on the wall or assembled in the space provided on the unit.

## Main components

1. Copper/aluminium exchanger, with hydrophilic coating
2. Electrical panel
3. L-Drain pan
4. 3/4" Water fittings
5. Condensate drain (Φ18,5mm)
6. Centrifugal fan
7. Washable filter (class G2)
8. Galvanised sheet metal casing

## Versions and configurations

### Versions:

**CFFC** - Cased version for vertical and horizontal installation, DC inverter motor

**CFFU** - Uncased version for vertical and horizontal installation, DC inverter motor

**CFFAC** - Cased version for vertical and horizontal installation, AC motor

**CFFAU** - Uncased version for vertical and horizontal installation, AC motor

### Fans type:

**VEC** - DC high efficiency fan (Standard for CFFC - CFFU models)

**VEN** - Three speed AC fan (Standard for CFFAC - CFFAU models)

### Connection side:

**SX** - Pipes connection on the left (default)

**DX** - Pipes connection on the right

### HMI on board:

**HMIDM** - KJRP-75 control mounted on board (only for versions DC CFFC)

**HMIAM** - KJRP-86R control mounted on board (only for versions AC CFFAC)

**Attention**, the following models are available on order only, please contact the sales network:

- DC, 2-pipe, front intake, cased
- DC, 4-pipe, bottom intake, cased and uncased
- DC, 4-pipe, Front intake, cased
- AC, 4-pipe, Front intake, cased
- AC, 4-pipe, bottom intake, cased

## Common accessories:

**BRVHX** - Auxiliary condensate collection tray auxiliary for vertical/horizontal installation

**KPDX** - Plinth kit

**3V2SX** - Three-way valve kit for 2-pipe type "on/off" system left fittings

**3V4SX** - Three-way valve kit for 4-pipe type "on/off" system left fittings

## AC accessories models (CFFAC - CFFAU):

**HMIFACX** - KJRP-86R user interface, wire for models AC CFFAC - CFFAU

**BOXX** - Wall installation with concealed box KJRP-86R user interface

**DCPRX** - Power interface to manage 4 fan coils and valves for 2-4 systems (For AC models)

## DC accessories models (CFFC - CFFU):

**HMIFDCX** - KJRP-75 user interface, wire for models DC inverter CFFC - CFFU

**HIDT19X** - Flush-mounted Electromechanical Thermostat + Modbus

**EXTENX** - KJRP-75 wired control connection cable extension (2m)

**KJR90X** - KJR-90D electronic room control for wall installation

**KJR150X** - Indoor units group controller

**CCM30-BX** - Centralized controller with case

**CCM-180A/WS** - Central controller for wall mounting weekly timer 6.2" (Refer to VRF price list)

**CCM-270A/WS** - Central controller for wall mounting weekly timer 10.1" (Refer to VRF price list)

**KCMDX** - Cables for motor connection for units with right fittings

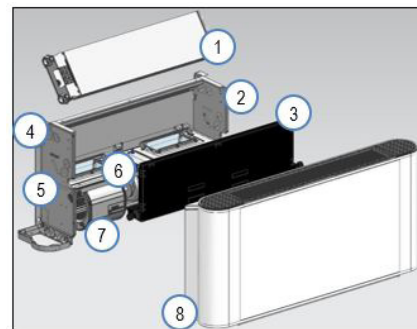

### Valves kit:

**3V2** - Three-way valve kit for 2-pipe "on/off" system (mounted on board)

**3V4** - Three-way valve kit for 4-pipe "on/off" system (mounted on board)

### Air intake:

**R3** - Bottom air intake

**RF** - Front air intake (only for cased versions CFFC, CFFAC)

### Coil configuration:

**CC2** - Coil configuration for 2-pipe system

**CC4** - Coil configuration for 4-pipe system

### Electronic Version:

**CTMP1** - Electronics with serial port RS485 Modbus, external control input 0/10V, 3-speed input (Standard for CFFC-CFFU models)

**TRB** - Terminal for motor connection (Standard for CFFAC-CFFAU models)

# Accessories separately supplied

## HMIFDCX

### User interface for DC inverter models

User interface KJRP-75 DC inverter models for wall or on-board installation

Functions:

- Backlit
- Basic functions
- 7 fan speeds + AUTO
- Follow-me (temperature reading from interface)

Cable length 85mm. Bidirectional control.



## HMIFACX

### User interface for AC models

User interface KJRP-86R AC models for wall or on-board installation three-speed

Functions:

- Backlit
- Basic functions
- 3 fan speeds + AUTO
- Timer
- Modbus Port
- Minimum water temperature probe

For wall installation refer to the BOXX accessory

⚠ Anti-cold/hot air function available only for CC2 configuration

⚠ When you want to use the KJRP-86R or any 3-speed control with DC inverter models, you must physically disconnect the KJRP-75A when the unit is OFF. If both inputs are maintained, the unit will still follow the KJRP-75A.



## DCPRX

### Power interface to manage 4 fan coils and valves for 2-4 systems (For AC models)

Accessory that can be combined with a 3-speed thermostat to manage assemblies with up to 4 terminal units with a 3-speed motor and ON/OFF valves. It is possible to combine several devices to create larger assemblies with up to 16 units.

The device must be fitted on a DIN bar and is compatible with a KJRP-86R thermostat: it can be used for the centralised management of individual fan speeds.



## EXTENX

### KJRP-75 Wired Control Connection Cable Extension (2m)

2 m long extension cable for remote installation of the KJRP-75 (HMIDCX) user interface.

Refer to the user interface manual.



## 3V2X 3V4X

### Three-way valve kit for 2-pipe type "on/off" system

### Three-way valve kit for 4-pipe type "on/off" system

Kit consisting of 3-way on/off valves and fittings for connection to the unit.

Compatible with BRVHX auxiliary condensate drain pan if the water pipes come out of the wall (vertical installation) or ceiling (horizontal installation).

Not compatible with BRVHX auxiliary condensate drain pan if the water pipes come out of the floor (vertical installation) or from behind the unit (horizontal installation) or from the side of the unit. In this case, the installer shall supply and install the thermal insulation of the valve kit.

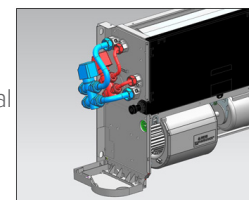

3V2SX - 3V4SX: kit for pipes on the left

## BRVHX

### Auxiliary condensate collection tray auxiliary for vertical/horizontal installation

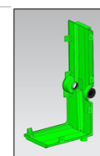

## KPDX

### Plinth kit

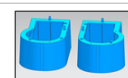

## BOXX

### Box for wall installation of KJRP-86R user interface

Wall built-in electrical box measuring LxHxD (mm) 86x86x33 suitable for wall installation of the KJRP-86R (HMIACX) user interface.

Once installed, the interface protrudes 9 mm from the flush wall.

Refer to the user interface manual.

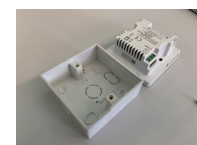

## KCMDX

### Cavi per collegamento motore per unità con attacchi a destra

(Per rotazione connessioni in cantiere)

Qualora la batteria dovesse essere ruotata in cantiere da sinistra a destra, sarà necessario utilizzare un cavo più lungo (accessorio KCMDX) per di collegamento tra motore e quadro elettrico.



⚠ Accessorio disponibile solo per versione SX

⚠ Accessorio disponibile solo modelli DC nelle taglie 9-10-11-12

## CCM30-BX Centralized controller with case for DC inverter models



The centralized controllers are multifunctional devices that can control up to 64 indoor units within a maximum connection length of 1.200m. These controls give the user the opportunity to control multiple units as a single group, or alternatively to assign an individual temperature for each on



### Single/unified control mode

Controllers can be toggled between unified and single control modes, to enable either unified control of all units or control of a specific unit. Operating mode feedback is used to ensure that all units are operating in the mode specified by the user.

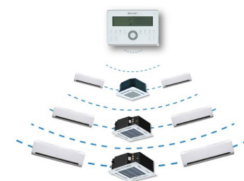

### Multi-system control

Controlled units can be from different VRF/Mini VRF systems, totally up to 64 indoor units: this allows a centralized control that facilitates the building management. Ensure that the address is not repeated for more units.



### Fancoil units operating status display

Error and protection codes are shown directly on centralized controllers' displays, avoiding the need to access outdoor units' PCBs to obtain codes during a system event. A wide range of error and protection codes provide system status information to building management professionals before contacting a service engineer.

Codice di errore e di protezione										Matrice status unità														
Current	Set. temp	Mode		Auto		Query Set Opr. unsuccess																		
88#	ALL Protect 88	Mode	Auto	00 01 02 03 04 05 06 07 08 09 10 11 12 13 14 15																				
Online ON OFF Error	88	Mode	Auto	16 17 18 19 20 21 22 23 24 25 26 27 28 29 30 31																				
T2A T2B T3	Period Room. temp	Mode	Auto	32 33 34 35 36 37 38 39 40 41 42 43 44 45 46 47																				
1 2 3 4	ON OFF 88:80	Mode	Auto	48 49 50 51 52 53 54 55 56 57 58 59 60 61 62 63																				
Week Sun Mon Tue Wed Thu Fri Sat	88:18 28 28:88	Fan	Weekly Timer Off																					

### Multiple lock modes

In addition to locking the centralized controller's own keyboard, the centralized controller may also be used to lock each unit's operating mode or remote controller.

### Clean filter reminder

The CCM30BX record the total running time of each indoor unit. When the accumulated running time reaches the value pre-set by the user, the system reminds the user to clean the indoor unit's filter, ensuring that the airflow does not become obstructed.



Model	CCM30BX
Dimensions LxAxP (mm)	180x122x78
Power supply	198-242V (50/60Hz)

# Accessories separately supplied

## CCM30-BX Centralized controller with case for DC inverter models

### Main features

- Setting On/Off
  - Setting mode Cool/Heat/Auto/Dry/Fan
  - Setting temperature
  - Fan speed selection High/Medium/Low/Auto
  - Air swing function
  - 24h On/Off timer
  - Locking the controller buttons
  - Air filter cleaning reminder
- Turn On/Off the LCD backlight



### Installation schematic

The centralized controller can connect up to 64 indoor units on the network monitoring and building management systems.

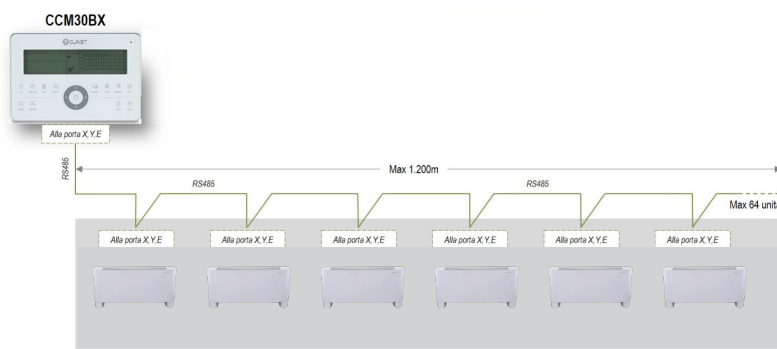

## KJR90X

### KJR-90D electronic room control for wall installation for DC inverter models

KJR90 LCD “touch-key” wall-mounted control.

Functions:

- On/Off
- Operation selection: Auto, Heating, Cooling, Dehumidification, Ventilation
- Temperature setting (temperature range selectable: 17~30°C)
- Set the fan speed (MIN - MED - MAX or AUTO)
- Timer setting
- Setting of deflectors position (swing)

Many additional functions such as:

- ECO mode
- Controller keypad lock
- Timed remainder air filter cleaning

The controller can be easily connected to the internal unit display by means of a connecting cable.

The control can be installed up to a max. distance of 15mt.

The controller combined with this unit does not provide an auto-restart function.



## KJR150X

### Indoor units group controller for DC inverter models

Allows the group control of up to 16 fancoil units from a single wall control KJR90X.

Each unit's operating parameters can also be individually controlled using its own remote controller R05.

 The controller does not guarantee the follow-me function.



## HIDTi9X Flush-mounted Electromechanical Thermostat + Modbus (for AC motors)

User interface with backlit LCD display for wall installation..

Equipped with a temperature probe and built-in Modbus port (RS485), for:

- Heat/Cool/Auto/Manual mode selection
- Comfort and Economy mode selection
- Room temperature measurement and display via built-in sensors or external signal
- Automatic or manual selection of the 3 fan speeds (MIN – MED – MAX)
- Control of On/Off valves, 3-point servo controls, heaters, heat pumps
- Management of set points and main control parameters
- Dirty filter warning
- Keypad lock (automatic, manual or via bus)
- Parametric start-up and control on the keypad or via bus.

Furthermore, there are 2 multifunctional inputs available for:

- Keycard, display contact or presence management
- Automatic Heat/Cool changeover sensor input
- Outdoor temperature sensor input with screen display
- Outdoor humidity sensor input (Dew point)
- Alarm input
- Mode change or temperature probe



## CCM-180 CCM-270

## CCM180X - Central controller for wall mounting weekly timer 6.2' (Riferirsi al listino VRF) CCM270X - Central controller for wall mounting weekly timer 10.1' (Riferirsi al listino VRF).

### Advanced Centralized Controllers.

The colorful touch screen and lively display make the interface more convenient and simple.

The controller recognizes the model of indoor and outdoor units and different models are represented by different icons.

Units can be viewed according to group, system or location, making unit management clearer and more convenient.

**Daily, weekly or annual schedules** can be used to set unit settings such as on/off, operating mode, set temperature, fan speed and swing.

**User can set limits or locks on an indoor unit**, such as minimum cooling temperature, maximum heating temperature, fan speed lock, operation mode lock, swing lock, remote controller lock and wired controller lock.

By importing floor **plans** and then dragging and dropping the indoor units to their actual positions on the floor plan, users can create a tailored system schematic which enables monitoring and control of the indoor units through a clear visual representation of the system layout.

A desktop or laptop PC can be used for browser-based access via a LAN connection.



⚠ For a list of functions compatible with AURA, refer to the centralised control manual.

⚠ For the selection, price and discount of these accessories refer to the VRP price list, please contact the sales network.

# General technical data

## DC Version - CFFC - CFFU, Downward air return (Vertical installation) / intake (horizontal installation) 2-pipe

SIZE		1	2	3	4	6	8	10	12		
<b>High speed</b>											
Airflow		m <sup>3</sup> /h	255	255	400	425	595	800	1190	1300	
Cooling capacity	(1)	kW	1,50	1,95	2,35	2,85	3,90	4,85	6,35	8,25	
Sensible capacity	(1)	kW	1,14	1,42	1,79	2,06	2,90	3,63	4,98	6,12	
Water flow-rate	(1)	l/h	260	330	400	490	670	830	1090	1430	
Water pressure drop	(1)	kPa	13,9	27,2	13,3	26	37,4	54,3	32,8	71,4	
Heating capacity	(2)	kW	1,57	2,05	2,60	2,95	4,00	5,25	7,05	8,70	
Water flow-rate	(2)	l/h	270	350	450	510	700	910	1220	1510	
Water pressure drop	(2)	kPa	15,1	25,3	14,3	24,4	36,5	53,4	37,6	62,6	
Total power input		W	15	19	16	18	28	47	87	106	
<b>Medium speed</b>											
Airflow		m <sup>3</sup> /h	170	210	315	300	450	600	875	980	
Cooling capacity	(1)	kW	1,06	1,66	1,94	2,13	3,20	3,92	5,19	6,65	
Sensible capacity	(1)	kW	0,77	1,19	1,44	1,51	2,35	2,85	3,98	4,82	
Water flow-rate	(1)	l/h	180	280	340	370	550	670	900	1140	
Water pressure drop	(1)	kPa	8,21	20,88	9,98	15,06	25,91	36,81	21,75	46,17	
Heating capacity	(2)	kW	1,07	1,75	2,11	2,15	3,22	4,09	5,61	6,81	
Water flow-rate	(2)	l/h	190	300	370	370	560	710	980	1180	
Water pressure drop	(2)	kPa	7,63	19,65	10,33	13,65	25,34	36,54	25,47	41,06	
Total power input		W	9	14	11	11	17	25	44	51	
<b>Low speed</b>											
Airflow		m <sup>3</sup> /h	150	150	190	190	310	420	530	680	
Cooling capacity	(1)	kW	0,92	1,21	1,19	1,41	2,43	2,93	3,62	4,84	
Sensible capacity	(1)	kW	0,66	0,85	0,86	0,96	1,72	2,08	2,68	3,42	
Water flow-rate	(1)	l/h	160	210	210	240	420	510	630	830	
Water pressure drop	(1)	kPa	6,16	12,2	4,59	7,41	15,37	21,77	11,43	25,39	
Heating capacity	(2)	kW	0,92	1,25	1,34	1,42	2,39	3,04	3,83	4,85	
Water flow-rate	(2)	l/h	160	220	230	240	410	530	670	830	
Water pressure drop	(2)	kPa	5,84	10,25	4,5	6,64	14,22	20,47	12,5	21,68	
Total power input		W	8	9	7	8	10	13	18	22	
Standard power supply		V	220-240/1/50								
Type of supply fan	(3)	-	CFG								
No. of supply fans		-	1	1	2	2	2	2	3	3	

The Product is compliant with the Erp (Energy Related Products) European Directive. It includes the Commission delegated Regulation (EU) No 2016/2281, also known as Ecodesign Lot21.  
Airflow with free outlet (0 Pa static pressure)

- (1) Entering exchanger water 7°C (temperature differential 5°C) - Ambient air 27°C D.B. / 19°C W.B.  
(2) Entering exchanger water 45°C (temperature differential 5°C) - Ambient air 20°C  
(3) CFG = centrifugal fan

### Performance in heating and cooling mode when the environment and system conditions change

Refer to the selection software or to the "CFF AURA DC and AC performance tables" which can be downloaded at <https://world.clivet.it/>

## DC Version CFFC, front intake, (vertical installation) / bottom intake (horizontal installation), 2-pipe (only on order)

SIZE		2	4	6	
<b>High speed</b>					
Airflow		m <sup>3</sup> /h	245	380	580
Cooling capacity	(1)	kW	1,87	2,55	3,80
Sensible capacity	(1)	kW	1,36	1,84	2,83
Water flow-rate	(1)	l/h	320	440	650
Water pressure drop	(1)	kPa	26,10	23,20	36,50
Heating capacity	(2)	kW	1,97	2,63	3,90
Water flow-rate	(2)	l/h	340	450	670
Water pressure drop	(2)	kPa	24,00	21,80	35,60
Total power input		W	20	21	30
<b>Medium speed</b>					
Airflow		m <sup>3</sup> /h	180	240	430
Cooling capacity	(1)	kW	1,59	1,90	3,11
Sensible capacity	(1)	kW	1,14	1,35	2,29
Water flow-rate	(1)	l/h	270	330	530
Water pressure drop	(1)	kPa	20,10	13,50	25,30
Heating capacity	(2)	kW	1,68	1,92	3,13
Water flow-rate	(2)	l/h	290	330	540
Water pressure drop	(2)	kPa	18,80	12,20	24,70
Total power input		W	16	12	18
<b>Low speed</b>					
Airflow		m <sup>3</sup> /h	130	110	300
Cooling capacity	(1)	kW	1,16	1,26	2,36
Sensible capacity	(1)	kW	0,81	0,85	1,67
Water flow-rate	(1)	l/h	200	220	400
Water pressure drop	(1)	kPa	11,80	6,60	15,00
Heating capacity	(2)	kW	1,20	1,27	2,43
Water flow-rate	(2)	l/h	210	220	400
Water pressure drop	(2)	kPa	9,90	5,90	13,90
Total power input		W	11	8	12
Standard power supply		V		220-240/1/50	
Type of supply fan	(3)	-		Centrifugo DC	
No. of supply fans		-	1	2	2
Numero ventilatore mandata		-			

The Product is compliant with the Erp (Energy Related Products) European Directive. It includes the Commission delegated Regulation (EU) No 2016/2281, also known as Ecodesign Lot21.  
Airflow with free outlet (0 Pa static pressure)

(1) Entering exchanger water 7°C (temperature differential 5°C) - Ambient air 27°C D.B. / 19°C W.B.  
(2) Entering exchanger water 45°C (temperature differential 5°C) - Ambient air 20°C  
(3) CFG = centrifugal fan

### Performance in heating and cooling mode when the environment and system conditions change

Refer to the selection software or to the "CFF AURA DC and AC performance tables" which can be downloaded at <https://world.clivet.it/>

# General technical data

## AC Version CFFAC - CFFAU, Downward air return (Vertical installation) / intake (horizontal installation) 2-pipe

SIZE – CFF		1	2	3	4	6	8	10	12		
<b>High speed</b>											
Airflow		m <sup>3</sup> /h	255	255	400	425	595	800	1150	1300	
Cooling capacity	(1)	kW	1,65	2,25	2,65	3,05	4,2	5,35	6,75	8,25	
Sensible capacity	(1)	kW	1,25	1,65	2,05	2,23	3,05	3,96	5,09	6,08	
Water flow-rate	(1)	l/h	283	386	454	523	720	917	1157	1414	
Water pressure drop	(1)	kPa	15,75	33,19	18,03	26,71	41,15	61,48	40,26	64,72	
Heating capacity	(2)	kW	1,85	2,35	3,05	3,15	4,3	5,7	7,15	8,5	
Water flow-rate	(2)	l/h	317	403	523	540	740	977	1226	1457	
Water pressure drop	(2)	kPa	15,13	33,19	17,56	23,31	37,2	60,89	42,16	61,96	
Total power input		W	35	40	47	47	51	91	110	118	
<b>Medium speed</b>											
Airflow		m <sup>3</sup> /h	165	192	273	284	450	574	885	1132	
Cooling capacity	(1)	kW	1,22	1,85	2,02	2,26	3,38	4,25	5,8	7,52	
Sensible capacity	(1)	kW	0,88	1,35	1,5	1,61	2,43	3,08	4,36	5,53	
Water flow-rate	(1)	l/h	209	317	346	387	580	729	995	1289	
Water pressure drop	(1)	kPa	9,33	22,37	11,18	15,66	27,07	41,44	29,2	55,03	
Heating capacity	(2)	kW	1,29	1,87	2,24	2,28	3,43	4,36	5,81	7,6	
Water flow-rate	(2)	l/h	222	320	384	392	590	747	996	1302	
Water pressure drop	(2)	kPa	8,22	22,37	10,28	12,57	24,5	37,73	28,68	47,46	
Total power input		W	17	24	26	26	32	54	89	104	
<b>Low speed</b>											
Airflow		m <sup>3</sup> /h	142	139	180	184	319	404	591	836	
Cooling capacity	(1)	kW	1,09	1,4	1,4	1,58	2,48	3,31	4,24	5,87	
Sensible capacity	(1)	kW	0,78	1	1,02	1,08	1,73	2,34	3,12	4,21	
Water flow-rate	(1)	l/h	186	241	240	272	425	567	727	1007	
Water pressure drop	(1)	kPa	7,37	4,64	5,48	8,42	15,71	26,62	16,15	34,88	
Heating capacity	(2)	kW	1,13	1,42	1,52	1,6	2,52	3,31	4,3	5,9	
Water flow-rate	(2)	l/h	194	244	260	275	433	569	740	1015	
Water pressure drop	(2)	kPa	6,64	4,64	5,43	6,11	13,75	21,79	14,66	28,84	
Total power input		W	14	15	14	14	19	35	64	82	
Standard power supply		V	220-240/1/50								
Type of supply fan	(3)	-	CFG								
No. of supply fans		-	1	1	2	2	2	2	3	3	

The Product is compliant with the Erp (Energy Related Products) European Directive. It includes the Commission delegated Regulation (EU) No 2016/2281, also known as Ecodesign Lot21.  
Airflow with free outlet (0 Pa static pressure)

(1) Entering exchanger water 7°C (temperature differential 5°C) - Ambient air 27°C D.B. / 19°C W.B.  
(2) Entering exchanger water 45°C (temperature differential 5°C) - Ambient air 20°C  
(3) CFG = centrifugal fan

### Performance in heating and cooling mode when the environment and system conditions change

Refer to the selection software or to the "CFF AURA DC and AC performance tables" which can be downloaded at <https://world.clivet.it/>

## AC Version CFFAC, front intake (vertical installation) / bottom intake, (horizontal installation), 2-pipe

SIZE – CFF		2	4	6	
<b>High speed</b>					
Airflow		m <sup>3</sup> /h	245	380	580
Cooling capacity	(1)	kW	2,16	2,72	4,09
Sensible capacity	(1)	kW	1,58	2,00	2,97
Water flow-rate	(1)	l/h	370	470	700
Water pressure drop	(1)	kPa	31,90	23,90	40,10
Heating capacity	(2)	kW	2,26	2,81	4,19
Water flow-rate	(2)	l/h	390	480	720
Water pressure drop	(2)	kPa	31,90	22,50	36,30
Total power input		W	40	47	51
<b>Medium speed</b>					
Airflow		m <sup>3</sup> /h	180	250	430
Cooling capacity	(1)	kW	1,78	2,02	3,29
Sensible capacity	(1)	kW	1,29	1,44	2,37
Water flow-rate	(1)	l/h	310	350	560
Water pressure drop	(1)	kPa	23,20	14,00	26,40
Heating capacity	(2)	kW	1,79	2,04	3,34
Water flow-rate	(2)	l/h	310	350	570
Water pressure drop	(2)	kPa	21,50	12,60	25,40
Total power input		W	24	26	32
<b>Low speed</b>					
Airflow		m <sup>3</sup> /h	130	160	310
Cooling capacity	(1)	kW	1,35	1,41	2,41
Sensible capacity	(1)	kW	0,96	1,02	1,68
Water flow-rate	(1)	l/h	230	240	410
Water pressure drop	(1)	kPa	14,10	7,50	15,30
Heating capacity	(2)	kW	1,36	1,43	2,45
Water flow-rate	(2)	l/h	230	250	420
Water pressure drop	(2)	kPa	14,10	6,10	14,50
Total power input		W	15	15	19
Standard power supply		V		220-240/1/50	
Type of supply fan	(3)	-		Centrifugo AC	
No. of supply fans		-	1	2	2

The Product is compliant with the Erp (Energy Related Products) European Directive. It includes the Commission delegated Regulation (EU) No 2016/2281, also known as Ecodesign Lot21.  
Airflow with free outlet (0 Pa static pressure)

- (1) Entering exchanger water 7°C (temperature differential 5°C) - Ambient air 27°C D.B. / 19°C W.B.  
(2) Entering exchanger water 45°C (temperature differential 5°C) - Ambient air 20°C  
(3) CFG = centrifugal fan

### Performance in heating and cooling mode when the environment and system conditions change

Refer to the selection software or to the "CFF AURA DC and AC performance tables" which can be downloaded at <https://world.clivet.it/>

# General technical data

## DC Version CFFC - CFFU, bottom intake, (vertical installation) /intake (horizontal installation)4-pipe (only on order)

SIZE		3	5	9	
<b>High speed</b>					
Airflow		m <sup>3</sup> /h	425	595	1190
Cooling capacity	(1)	kW	2,70	3,80	6,05
Sensible capacity	(1)	kW	1,90	2,80	4,80
Water flow-rate	(1)	l/h	460	650	1040
Water pressure drop	(1)	kPa	16,97	39,17	53,66
Heating capacity	(2)	kW	2,30	2,88	4,60
Water flow-rate	(2)	l/h	200	250	390
Water pressure drop	(2)	kPa	28,16	55,37	132,32
Total power input		W	20	29	92
<b>Medium speed</b>					
Airflow		m <sup>3</sup> /h	280	461	887
Cooling capacity	(1)	kW	1,94	3,18	5,00
Sensible capacity	(1)	kW	1,30	2,30	3,88
Water flow-rate	(1)	l/h	330	550	860
Water pressure drop	(1)	kPa	9,73	28,35	36,96
Heating capacity	(2)	kW	1,78	2,49	6,95
Water flow-rate	(2)	l/h	150	210	340
Water pressure drop	(2)	kPa	18,45	43,00	104,19
Total power input		W	11	17	46
<b>Low speed</b>					
Airflow		m <sup>3</sup> /h	158	324	564
Cooling capacity	(1)	kW	1,10	2,32	3,43
Sensible capacity	(1)	kW	0,70	1,61	2,53
Water flow-rate	(1)	l/h	190	400	590
Water pressure drop	(1)	kPa	3,51	16,91	19,07
Heating capacity	(2)	kW	1,22	2,00	3,02
Water flow-rate	(2)	l/h	100	170	260
Water pressure drop	(2)	kPa	10,08	29,20	63,73
Total power input		W	8	11	19
Standard power supply		V		220-240/1/50	
Type of supply fan	(3)	-		Centrifugo DC	
No. of supply fans		-	2		3

The Product is compliant with the Erp (Energy Related Products) European Directive. It includes the Commission delegated Regulation (EU) No 2016/2281, also known as Ecodesign Lot21.  
Airflow with free outlet (0 Pa static pressure)

(1) Entering exchanger water 7°C (temperature differential 5°C) - Ambient air 27°C D.B. / 19°C W.B.

(2) Entering exchanger water 65°C (temperature differential 10°C) - Ambient air 20°C

(3) CFG = centrifugal fan

### Performance in heating and cooling mode when the environment and system conditions change

Refer to the selection software or to the "CFF AURA DC and AC performance tables" which can be downloaded at <https://world.clivet.it/>

## AC Version CFFAC - CFFAU, bottom intake, (vertical installation) /rear intake (horizontal installation), 4-pipe (cased only on order)

SIZE – CFF			3	5	9
<b>High speed</b>					
Airflow		m3/h	425	595	1150
Cooling capacity	(1)	kW	2,89	4,09	6,40
Sensible capacity	(1)	kW	2,05	2,94	4,90
Water flow-rate	(1)	l/h	500	700	1100
Water pressure drop	(1)	kPa	21,38	47,70	63,05
Heating capacity	(2)	kW	2,45	2,95	4,65
Water flow-rate	(2)	l/h	210	250	400
Water pressure drop	(2)	kPa	32	58,2	135,2
Total power input		W	47	51	110
<b>Medium speed</b>					
Airflow		m3/h	284	430	885
Cooling capacity	(1)	kW	2,05	3,35	5,59
Sensible capacity	(1)	kW	1,39	2,38	4,25
Water flow-rate	(1)	l/h	350	570	960
Water pressure drop	(1)	kPa	11,95	33,04	48,47
Heating capacity	(2)	kW	1,7	2,5	4,09
Water flow-rate	(2)	l/h	150	210	350
Water pressure drop	(2)	kPa	16,8	43,4	111,8
Total power input		W	26	32	89
<b>Low speed</b>					
Airflow		m3/h	184	319	591
Cooling capacity	(1)	kW	1,25	2,35	4,00
Sensible capacity	(1)	kW	0,84	1,60	2,95
Water flow-rate	(1)	l/h	210	400	690
Water pressure drop	(1)	kPa	4,99	18,22	27,23
Heating capacity	(2)	kW	1,19	2	3,19
Water flow-rate	(2)	l/h	100	170	270
Water pressure drop	(2)	kPa	9,5	29,2	70,9
Total power input		W	14	19	64
Standard power supply	(3)	V		220-240/1/50	
Type of supply fan		-		Centrifugo	
No. of supply fans		-		2	3

The Product is compliant with the Erp (Energy Related Products) European Directive. It includes the Commission delegated Regulation (EU) No 2016/2281, also known as Ecodesign Lot21.  
Airflow with free outlet (0 Pa static pressure)

(1) Entering exchanger water 7°C (temperature differential 5°C) - Ambient air 27°C D.B. / 19°C W.B.  
(2) Entering exchanger water 65°C (temperature differential 10°C) - Ambient air 20°C  
(3) CFG = centrifugal fan

### Performance in heating and cooling mode when the environment and system conditions change

Refer to the selection software or to the "CFF AURA DC and AC performance tables" which can be downloaded at <https://world.clivet.it/>

# General technical data

## Electrical data

Version	Power supply	Size	MCA	MFA	IFM	
					KW	FLA
AC (CFFAC & CFFAU)	220-240V~50Hz	1-2	0,21	15	0,005	0,17
	220-240V~50Hz	3-4	0,30	15	0,008	0,24
	220-240V~50Hz	5-6	0,33	15	0,015	0,26
	220-240V~50Hz	8	0,55	15	0,037	0,44
	220-240V~50Hz	9-10	0,68	15	0,053	0,54
	220-240V~50Hz	12	0,68	15	0,053	0,54

MCA = Minimum circuit amps [A]

MFA = Maximum fuse amps [A]

IFM = Indoor fan motor

kW = Rated motor output [kW]

FLA = Full load current at max admissible conditions [A]

Maximum allowable voltage range variation between phases is 2%

Version	Power supply	Size	MCA	MFA	IFM	
					KW	FLA
DC (CFFC & CFFU)	220-240V~50Hz	1-2	0,48	15	0,03	0,38
	220-240V~50Hz	3-4	0,73	15	0,03	0,58
	220-240V~50Hz	5-6	0,73	15	0,03	0,58
	220-240V~50Hz	8	0,73	15	0,03	0,58
	220-240V~50Hz	9-10	1,56	15	0,06	1,25
	220-240V~50Hz	12	1,56	15	0,06	1,25

MCA = Minimum circuit amps [A]

MFA = Maximum fuse amps [A]

IFM = Indoor fan motor

kW = Rated motor output [kW]

FLA = Full load current at max admissible conditions [A]

Maximum allowable voltage range variation between phases is 2%

## Sound pressure levels

### DC Version CFFC - CFFU, bottom intake, 2-pipe

SIZE		1	2	3	4	6	8	9	10	12
High speed	dB(A)	34	39	29	32	40	45	50	50	50
Medium speed	dB(A)	24	33	24	23	34	39	42	43	43
Low speed	dB(A)	21	25	18	19	30	30	31	31	33

### DC Version CFFC, front intake, 2-pipe

SIZE		2	4	6
High speed	dB(A)	39	33	39
Medium speed	dB(A)	33	26	32
Low speed	dB(A)	26	17	24

### AC Version CFFAC - CFFAU, bottom intake, 2-pipe

SIZE		1	2	3	4	6	8	9	10	12
High speed	dB(A)	35	42	34	34	40	47	50	50	50
Medium speed	dB(A)	24	35	24	25	35	40	43	44	45
Low speed	dB(A)	21	27	18	19	31	31	33	33	37

### AC Version CFFAC, front intake, 2-pipe

SIZE		2	4	6
High speed	dB(A)	39	35	39
Medium speed	dB(A)	34	26	32
Low speed	dB(A)	26	20	24

### DC Version CFFC - CFFU, bottom intake, 4-pipe

SIZE		3	5	9
High speed	dB(A)	32	40	50
Medium speed	dB(A)	23	34	43
Low speed	dB(A)	19	30	31

### AC Version CFFAC - CFFAU, bottom intake, 4-pipe

SIZE		3	5	9
High speed	dB(A)	34	40	50
Medium speed	dB(A)	25	33	44
Low speed	dB(A)	19	24	33

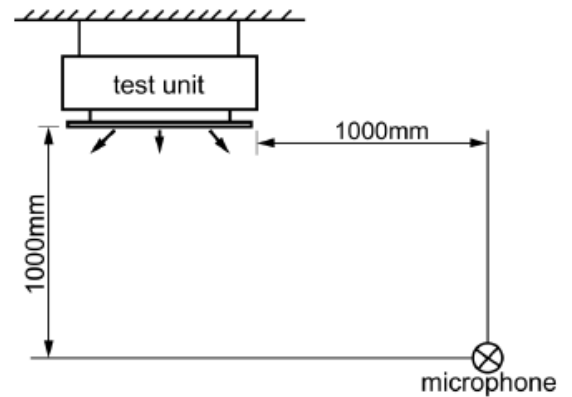

# General technical data

## Sound power levels

### DC Version CFFC - CFFU, bottom intake, 2-pipe

SIZE		1	2	3	4	6	7	8	10	12
High speed	dB(A)	47	52	43	46	52	59	29	62	63
Medium speed	dB(A)	36	46	37	37	45	51	51	56	57
Low speed	dB(A)	34	38	29	29	36	43	43	46	47

### DC Version CFFC, front intake, 2-pipe

SIZE		2	4	6
High speed	dB(A)	52	46	52
Medium speed	dB(A)	46	38	45
Low speed	dB(A)	39	30	37

### AC Version CFFAC - CFFAU, bottom intake, 2-pipe

SIZE		1	2	3	4	6	8	9	10	12
High speed	dB(A)	47	53	46	47	52	59	64	62	63
Medium speed	dB(A)	35	47	37	38	45	51	56	56	58
Low speed	dB(A)	34	39	31	32	37	43	45	46	50

### AC Version CFFAC, front intake, 2-pipe

SIZE		2	4	6
High speed	dB(A)	52	48	52
Medium speed	dB(A)	47	39	45
Low speed	dB(A)	39	33	37

### DC Version CFFC - CFFU, bottom intake, 4-pipe

SIZE		3	5	9
High speed	dB(A)	46	52	62
Medium speed	dB(A)	37	45	56
Low speed	dB(A)	29	36	46

### AC Version CFFAC - CFFAU, bottom intake, 4-pipe

SIZE		3	5	9
High speed	dB(A)	47	52	62
Medium speed	dB(A)	38	45	56
Low speed	dB(A)	32	37	46

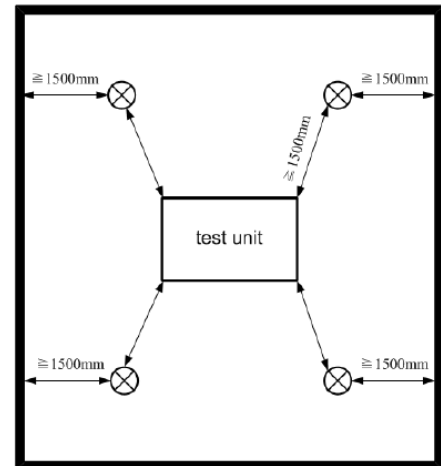

## Fan curves for uncased models

### DC CFFU Models

CFFU 1 CC2 R3

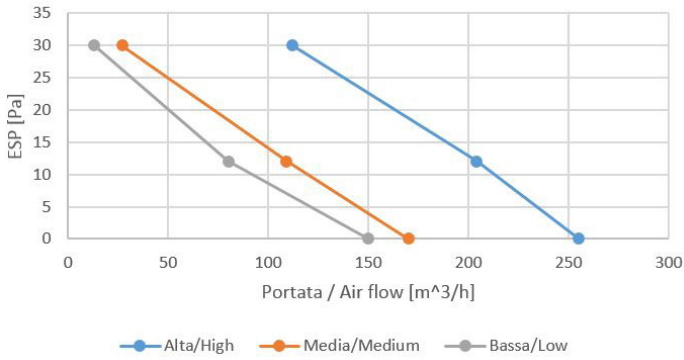

CFFU 2 CC2 R3

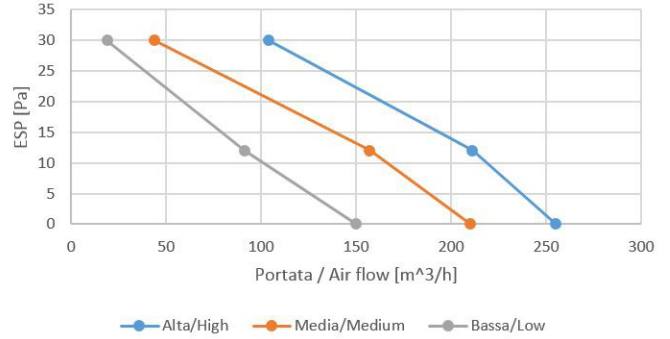

CFFU 3 CC2 R3

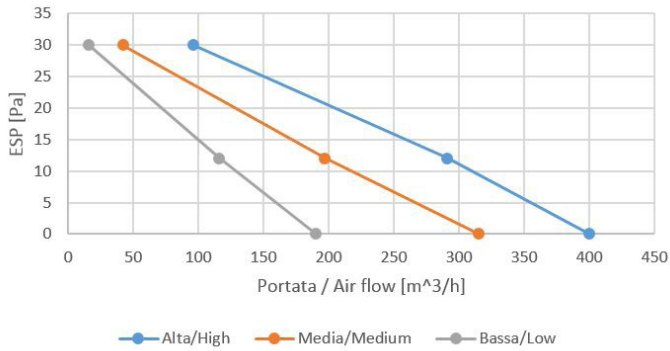

CFFU 4 CC2 R3

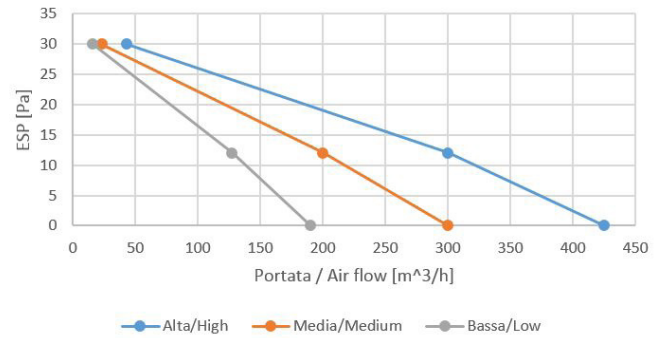

CFFU 6 CC2 R3

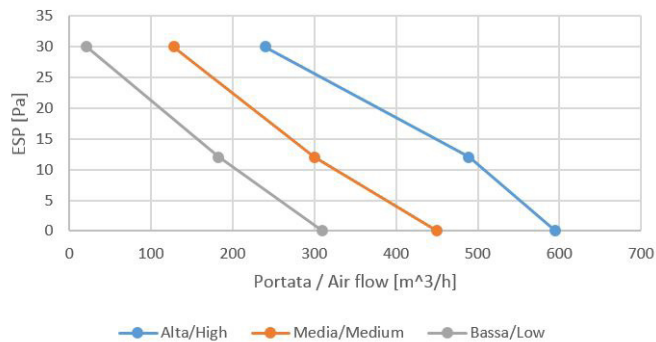

CFFU 8 CC2 R3

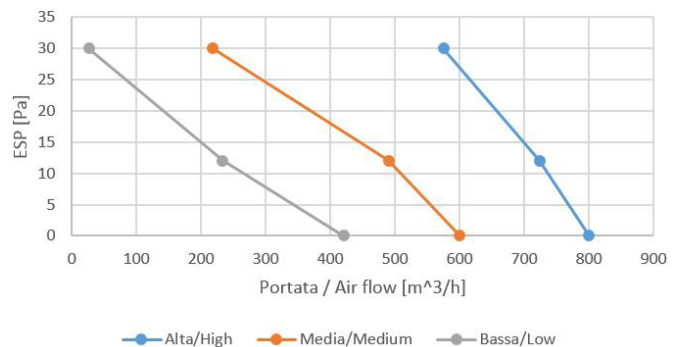

# General technical data

## Fan curves for uncased models

### DC CFFU Models

CFFU 10 CC2 R3

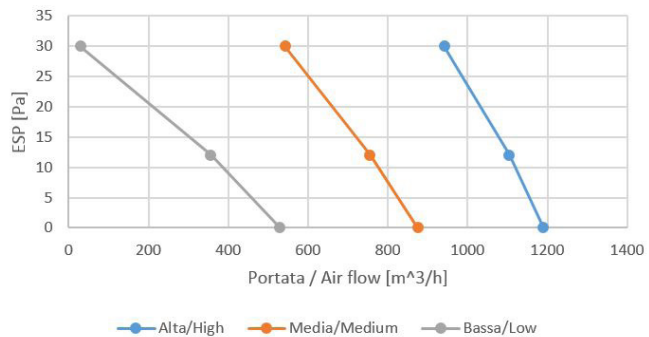

CFFU 12 CC2 R3

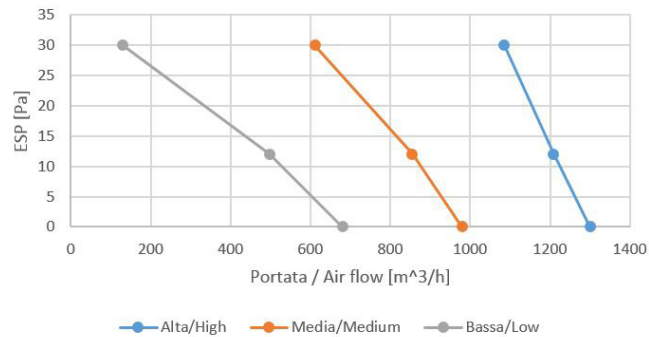

## Fan curves for uncased models

### AC CFFAU Models

CFFAU 1 CC2 R3

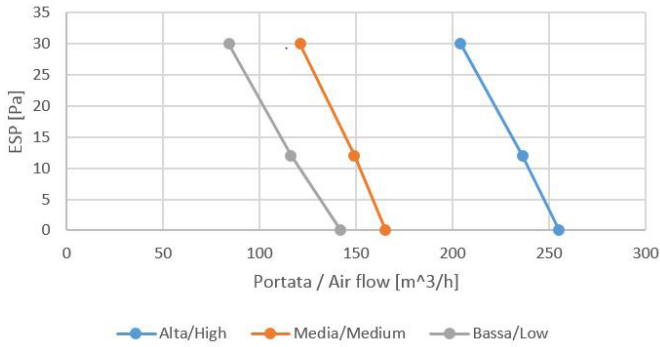

CFFAU 2 CC2 R3

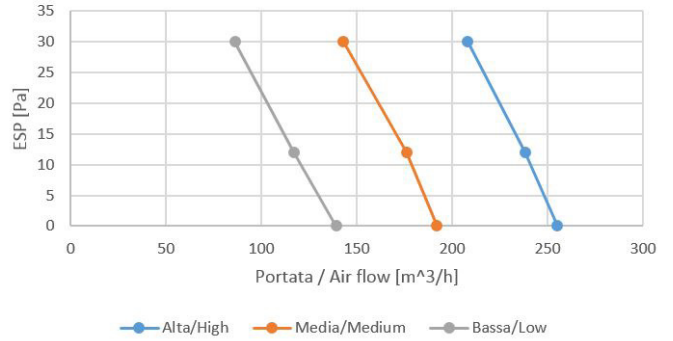

CFFAU 3 CC2 R3

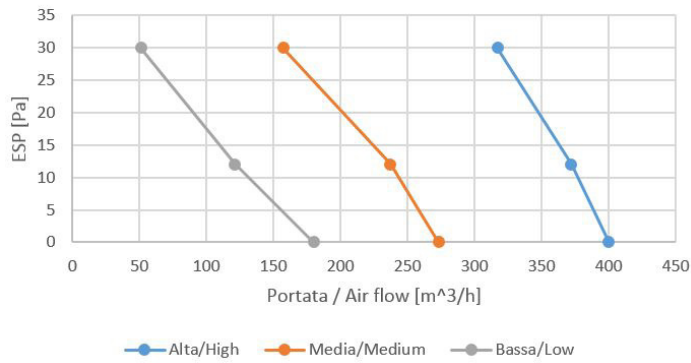

CFFAU 4 CC2 R3

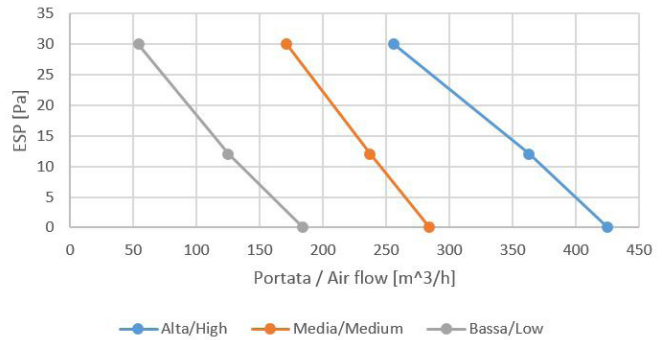

CFFAU 6 CC2 R3

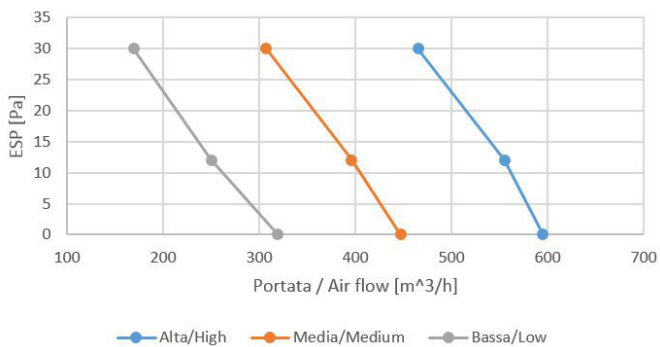

CFFAU 8 CC2 R3

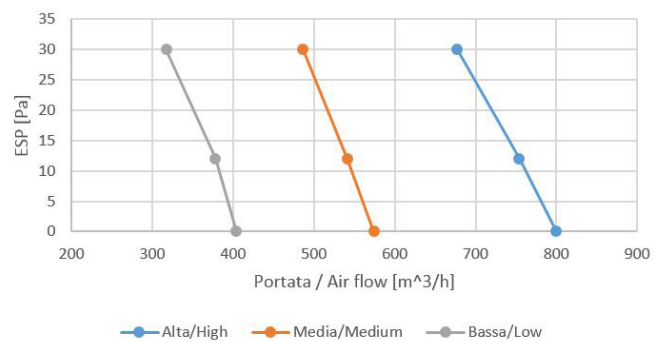

# General technical data

## Fan curves for uncased models

### AC CFFAU Models

CFFAU 10 CC2 R3

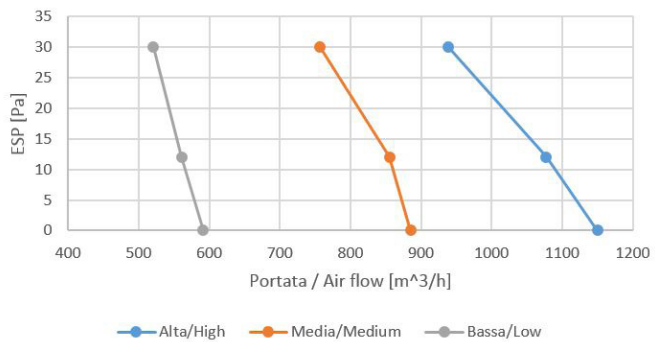

CFFAU 12 CC2 R3

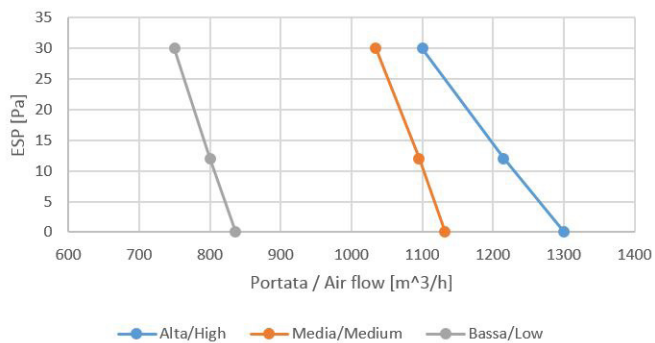

## CFFC - Cased version

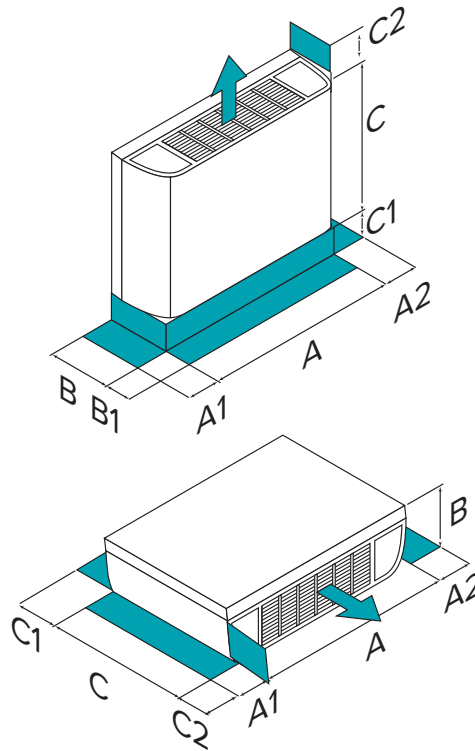

SIZE			1	2	3	4	5	6	8	9	10	12
CASED DIM.	A	mm	790	790	1020	1020	1240	1240	1240	1360	1360	1360
	B	mm	200	200	200	200	200	200	200	200	200	200
	C	mm	495	495	495	495	495	495	495	495	495	591
VERTICAL INST.	A1	mm	150	150	150	150	150	150	150	150	150	150
	A2	mm	150	150	150	150	150	150	150	150	150	150
	B1	mm	-	-	-	-	-	-	-	-	-	-
	C2	mm	150	150	150	150	150	150	150	150	150	150
	C1 (only for R3 configurations)	mm	90	90	90	90	90	90	90	90	90	90
HORIZONTAL INST.	A1	mm	150	150	150	150	150	150	150	150	150	150
	A2	mm	150	150	150	150	150	150	150	150	150	150
	B1 (only for R3 configurations)	mm	90	90	90	90	90	90	90	90	90	90
	B2	mm	150	150	150	150	150	150	150	150	150	150

- ⚠ Check that there is no condensation on the wall or object above the unit.
- ⚠ The presence of cluttering above the unit can reduce performance.

# Dimensions

## CFFU - Uncased version

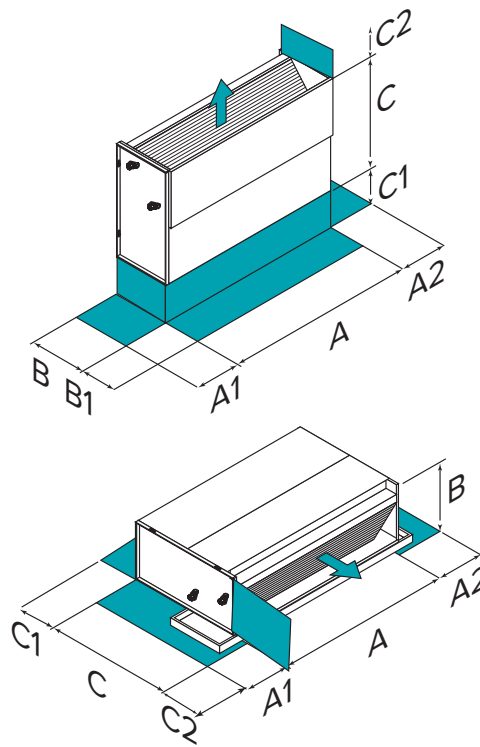

GRANDEZZE			1	2	3	4	5	6	8	9	10	12
UNCASED DIM.	A	mm	628	628	858	858	1078	1078	1078	1198	1198	1198
	B	mm	200	200	200	200	200	200	200	200	200	200
	C	mm	455	455	455	455	455	455	455	455	455	551
VERTICAL INST.	A1	mm	150	150	150	150	150	150	150	150	150	150
	A2	mm	150	150	150	150	150	150	150	150	150	150
	B1	mm	-	-	-	-	-	-	-	-	-	-
	C2	mm	150	150	150	150	150	150	150	150	150	150
HORIZONTAL INST.	C1	mm	90	90	90	90	90	90	90	90	90	90
	A1	mm	150	150	150	150	150	150	150	150	150	150
	A2	mm	150	150	150	150	150	150	150	150	150	150
	C2	mm	150	150	150	150	150	150	150	150	150	150

- ⚠ Check that there is no condensation on the wall or object above the unit.
- ⚠ The presence of cluttering above the unit can reduce performance.

## Weight table (net weight in Kg)

Size				1	2	3	4	5	6	8	9	10	12		
2-pipe	Cased	AC	Bottom intake	CFFAC CC2 R3	Kg	16,3	16,7	20	20,8	-	25,4	26,3	-	28,5	34
		AC	Front intake	CFFAC CC2 RF	Kg	-	16,7	-	20,8	-	25,4	-	-	28,5	-
		DC	Bottom intake	CFFC CC2 R3	Kg	18	18,5	21,5	22	-	26,5	26,5	-	29,5	34,5
	Uncased	DC	Front intake	CFFC CC2 RF	Kg	-	18,5	21,5	22	-	26,5	-	-	-	-
		AC	Bottom intake	CFFAU CC2 R3	Kg	11,6	12	13,9	14,8	17,3	18,2	18,8	20,5	21,7	25,2
		DC	Bottom intake	CFFU CC2 R3	Kg	11,8	12,1	13,9	14,8	-	18,2	18,2	-	20,8	24,3
4-pipe	Cased	AC	Bottom intake	CFFAC CC4 R3	Kg	-	-	21,3	-	25,9	-	-	29	-	-
		AC	Front intake	CFFAC CC4 RF	Kg	-	-	-	-	-	-	-	-	-	-
		DC	Bottom intake	CFFC CC4 R3	Kg	-	-	22,5	-	27	-	-	30	-	-
	Uncased	DC	Front intake	CFFC CC4 RF	Kg	-	-	-	-	-	-	-	-	-	-
		AC	Bottom intake	CFFAC CC4 R3	Kg	-	-	15,3	-	18,7	-	-	22,2	-	-
		DC	Bottom intake	CFFC CC4 R3	Kg	-	-	15,3	-	18,7	-	-	21,3	-	-

FOR OVER 30 YEARS WE HAVE BEEN  
OFFERING SOLUTIONS TO ENSURE  
SUSTAINABLE COMFORT AND THE WELL-  
BEING OF PEOPLE AND THE ENVIRONMENT

[www.clivet.com](http://www.clivet.com)

**MideaGroup**  
*humanizing technology*

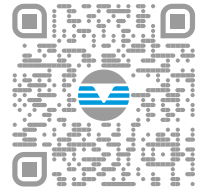

sale and assistance

AURA - SERIE CFF - CFFA 1-12 - BT20F011GB-10



**CLIVET S.p.A.**

Via Camp Lonc 25, Z.I. Villapaiera 32032 - Feltre (BL) - Italy  
Tel. +39 0439 3131 - [info@clivet.it](mailto:info@clivet.it)

**CLIVET GMBH**

Hummelsbütteler Steindamm 84,  
22851 Norderstedt, Germany  
Tel. +49 40 325957-0 - [info.de@clivet.com](mailto:info.de@clivet.com)

**Clivet Group UK LTD**

Units F5 & F6 Railway Triangle,  
Portsmouth, Hampshire PO6 1TG  
Tel. +44 02392 381235 -  
[Enquiries@Clivetgroup.co.uk](mailto:Enquiries@Clivetgroup.co.uk)

**CLIVET LLC**

Office 508-511, Elektrozavodskaya st. 24,  
Moscow, Russian Federation, 107023  
Tel. +7495 6462009 - [info.ru@clivet.com](mailto:info.ru@clivet.com)

**CLIVET MIDEAST FZCO**

Dubai Silicon Oasis (DSO) Headquarter Building,  
Office EG-05, P.O Box-342009, Dubai, UAE  
Tel. +9714 3208499 - [info@clivet.ae](mailto:info@clivet.ae)

**Clivet South East Europe**

Jarušćica 9b  
10000, Zagreb, Croatia  
Tel. +3851 222 8784 - [info.see@clivet.com](mailto:info.see@clivet.com)

**CLIVET France**

10, rue du Fort de Saint Cyr - 78180 Montigny le  
Bretonneux, France  
[info.fr@clivet.com](mailto:info.fr@clivet.com)

**Clivet Airconditioning Systems Pvt Ltd**

Office No.501 & 502,5th Floor, Commercial -I,  
Kohinoor City, Old Premier Compound, Off LBS  
Marg, Kirod Road, Kurla West, Mumbai  
Maharashtra 400070, India  
Tel. +91 22 30930200 - [sales.india@clivet.com](mailto:sales.india@clivet.com)