

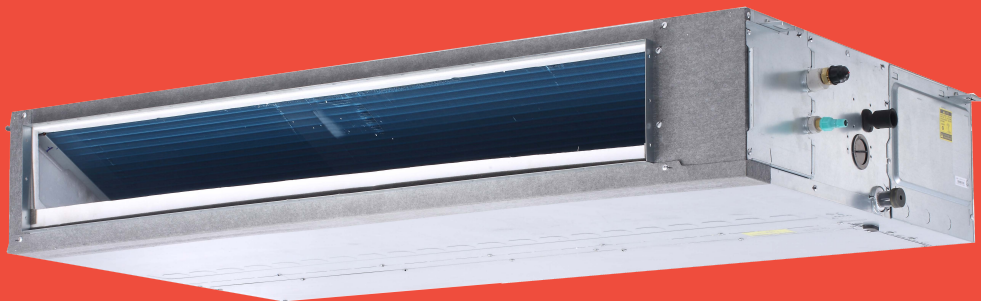

# MEDIUM STATIC PRESSURE DUCT

CNT2-3-XY series D15÷D160



**MANUAL**  
FOR INSTALLATION,  
USE AND MAINTENANCE

# PREFACE

## Dear user

Thank you very much for purchasing and using our product. Please read the Manual carefully during your installation, use, maintenance and troubleshooting of the product, so that you can have a pretty good knowledge of and use the product correctly.

The Manual only applies to the indoor units listed. For outdoor units or other indoor units, please refer to the installation and operation manual of the units involved.

Please refer to the manual of corresponding equipment for detailed operation of auxiliary control equipment such as wire controller, remote controller and centralized controller.

The following descriptions are provided for the correct installation and use of the product:

- ④ Please strictly follow the requirements of the Manual to ensure the correct and safe use of the product.
- ④ All illustrations and contents in the Manual are for reference only. We will continuously improve and innovate the product without prior notice to make it cater to you in a better manner.
- ④ The product needs to be cleaned and maintained on a regular basis to improve its air conditioning effect and extend its lifetime. Please contact your local service outlet before using the air conditioner every year. We will assign professional service personnel to provide you with paid cleaning, maintenance, and inspection services.
- ④ After reading the Manual, please keep it properly for reference when necessary.

# CONTENTS

## Safety Warning 1

---

Description of Warning Signs /1      Safety Precautions /2      Electrical Safety Requirements /3  
Appendix /4

## Operating Instructions 6

---

Precautions for Use /6      Optimal Operation Mode /7      Non-air Conditioner Fault /9  
Display components (optional) /11

## Installation Instructions 12

---

Precautions for Installation /12      Installation Material /17      Component Name /19  
Preparation before Installation /20      Installation of Indoor Units /22      Installation of Refrigerant Connecting Pipe /25  
Installation of Drainage Pipe /30      Installation of Air Duct /34      Electrical Wiring Operation /36  
Application Control /54      Test Run /65

## Maintenance and Service 67

---

Safety Warnings /67      Cleaning and Maintenance /67      Repair of Conventional Parts /70

For the contents and importance of the safety matters described herein, please read the text with a full understanding of the following contents (signs and icons), and be sure to observe the safety precautions to prevent personal injury or property damage to users or others.



# SAFETY WARNING

Explanation of symbols displayed on the unit

	WARNING	This symbol shows that this appliance used a flammable refrigerant. If the refrigerant is leaked and exposed to an external ignition source, there is a risk of fire.
	CAUTION	This symbol shows that the operation manual should be read carefully.
	CAUTION	This symbol shows that a service personnel should be handling this equipment with reference to the installation manual.
	CAUTION	This symbol shows that information is available such as the operating manual or installation manual.



Caution: Risk of fire

(for IEC 60335-2-40: 2018 only)



Caution: Risk of fire

(for IEC/EN 60335-2-40 except IEC 60335-2-40: 2018)

## [ Note ]

The symbols above is for R32 refrigerant system.

# 1 Description of Warning Signs

Different marks are used to indicate the levels of hazard severity. Please follow the instructions and ensure safe operation.

## [ Danger ]

In case of violations, serious injury or even death may occur.

## [ Warning ]

In case of violations, serious damage to the product and serious personal injury or even death, or electrical or fire hazards may occur.

## [ Caution ]

In case of violations, there will be a dangerous or unsafe situation that may result in minor personal injury or damage to products, equipment, and pro

## [ Note ]

Some useful operation and maintenance information.

## Warning signs



Effective grounding required



Professional staff required

## Installation prohibited



No inflammables



No Strong Current



No open flames



No acid and alkali substances

## 2 Safety Precautions

### [ Danger ]

In thunderstorm weather, please turn off the main power switch, or lightning may damage the unit and cause accidents.

When refrigerant leaks, there shall be no smoke and fire. In this case, immediately turn off the main power switch, open the window for ventilation, keep away from the leakage point, contact local dealers or service outlets, and ask professional and technical personnel to repair.

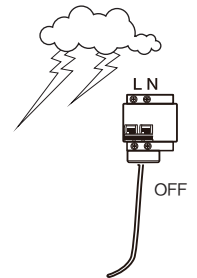

### [ Warning ]

The air conditioner shall be installed in such a way that the requirements of national standards and electrical specifications as well as the installation instructions herein are met.

Do not use liquid cleaners, liquefied cleaners, and corrosive cleaners to wipe the unit or sprinkle water or other liquids on it. Otherwise, its plastic parts will be damaged, and electric shock may occur in severe cases. Please turn off the main power switch before cleaning or maintenance of the unit; otherwise, accidents may occur.

To remove and reinstall the air conditioner, please ask a professional technician for help.

Please contact a professional technician for maintenance and repair.

The air conditioner is classified as "an appliance not accessible to the general public".

The indoor unit shall be placed at a position out of the reach of children and at least 2.5 m above the ground.

The refrigerant leakage sensor is installed 1500mm above the ground.

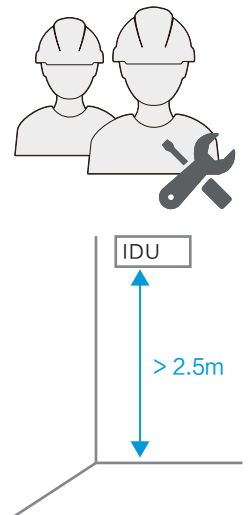

### [ Caution ]

This appliance is not intended for use by persons (including children) with reduced physical, sensory or mental capabilities, or lack of experience and knowledge, unless they have been given supervision or instruction concerning use of the appliance by a person responsible for their safety.

Children should be supervised to ensure that they do not play with the appliance.

This appliance can be used by children aged from 8 years and above and persons with reduced physical, sensory or mental capabilities or lack of experience and knowledge if they have been given supervision or instruction concerning use of the appliance in a safe way and understand the hazards involved. (Only European)

Children shall not play with the appliance. (Only European)

Cleaning and user maintenance shall not be made by children without supervision. (Only European)

This appliance is intended to be used by expert or trained users in shops, in light industry and on farms, or for commercial use by lay persons. (EN 60335-2-40:2003/A13:2012)

When the product is used for commercial application. This appliance is intended to be used by expert or trained users in shops, in light industry and on farms, or for commercial use by lay persons, the sound pressure level is below 70 dB(A).

# 3 Electric Safety Requirements

## [ Warning ]

- The air conditioner shall be installed according to national wiring specifications.
  - Wiring work must be performed by a duly qualified electrician.
  - All wiring work must comply with electrical safety specifications.
  - The air conditioner must be well-grounded, which means the main switch of the air conditioner must have a reliable grounding wire.
  - Disconnect all power supplies before contacting the junction device.
  - Do not remove or repair the air conditioner by yourself; otherwise, danger may occur. In case of any fault, please cut off the power supply immediately and contact the local dealer or local service outlet.
  - A separate power supply meeting the requirements of rated parameters must be provided for the air conditioner.
  - The fixed wiring connected to the air conditioner must be installed with a device to disconnect the power supply according to the wiring rules.
  - If the power cord is damaged, it must be replaced by a professional from the manufacturer's maintenance department or similar department to avoid danger.
  - The air conditioner's circuit board (PCB) is designed with a fuse to provide overcurrent protection.
  - The specifications of the fuse are printed on the circuit board.
- NOTE:** For the units with R32 refrigerant , only the blast-proof ceramic fuse can be used.

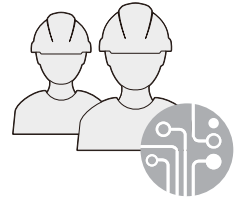
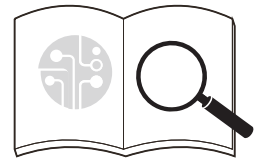

## [ Caution ]

- Do not disconnect the ground wire of the main power switch under any circumstances.
- Do not use a damaged power cable. Replace it immediately if any damage is found.
- Power on and preheat the air conditioner for at least 12 hours before use if it has never been used or been powered off for a long time.

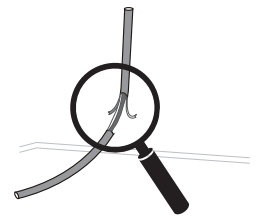

# 4 Appendix

## [ Warning ]

- The following applies to r32 refrigerant systems.
- Prior to beginning work on systems containing flammable refrigerants, safety checks are necessary to ensure that the risk of ignition is minimized.
- For repair to the refrigerating system, the following precautions shall be complied with prior to conducting work on the system.
- Work shall be undertaken under a controlled procedure so as to minimise the risk of a flammable gas or vapour being present while the work is being performed.
- All maintenance staff and others working in the local area shall be instructed on the nature of work being carried out. Work in confined spaces shall be avoided. The area around the workspace shall be sectioned off. Ensure that the conditions within the area have been made safe by control of flammable material.
- The area shall be checked with an appropriate refrigerant detector prior to and during work, to ensure the technician is aware of potentially flammable atmospheres.
- Ensure that the leak detection equipment being used is suitable for use with flammable refrigerants, i.e. non-sparking, adequately sealed or intrinsically safe.
- If any hot work is to be conducted on the refrigeration equipment or any associated parts, appropriate fire extinguishing equipment shall be available to hand. Have a dry powder or CO2 fire extinguisher adjacent to the charging area.
- No person carrying out work in relation to a refrigeration system which involves exposing any pipe work that contains

or has contained flammable refrigerant shall use any sources of ignition in such a manner that it may lead to the risk of fire or explosion.

All possible ignition sources, including cigarette smoking, should be kept sufficiently far away from the site of installation, repairing, removing and disposal, during which flammable refrigerant can possibly be released to the surrounding space.

Prior to work taking place, the area around the equipment is to be surveyed to make sure that there are no flammable hazards or ignition risks. "No Smoking" signs shall be displayed.

Ensure that the area is in the open or that it is adequately ventilated before breaking into the system or conducting any hot work. A degree of ventilation shall continue during the period

that the work is carried out. The ventilation should safely disperse any released refrigerant and preferably expel it externally into the atmosphere.

Where electrical components are being changed, they shall be fit for the purpose and to the correct specification. At all times the manufacturer's maintenance and service guidelines shall be followed. If in doubt consult the manufacturer's technical department for assistance.

**The following checks shall be applied to installations using flammable refrigerants:**

- the charge size is in accordance with the room size within which the refrigerant containing parts are installed;
- the ventilation machinery and outlets are operating adequately and are not obstructed;
- if an indirect refrigerating circuit is being used, the secondary circuit shall be checked for the presence of refrigerant;
- marking to the equipment continues to be visible and legible. Markings and signs that are illegible shall be corrected;
- refrigeration pipe or components are installed in a position where they are unlikely to be exposed to any substance which may corrode refrigerant containing components, unless the components are constructed of materials which are inherently resistant to being corroded or are suitably protected against being so corroded.

**Repair and maintenance to electrical components shall include initial safety checks and component inspection procedures.**

If a fault exists that could compromise safety, then no electrical supply shall be connected to the circuit until it is satisfactorily dealt with. If the fault cannot be corrected immediately but it is necessary to continue operation, an adequate temporary solution shall be used. This shall be reported to the owner of the equipment so all parties are advised.

**Initial safety checks shall include:**

- that capacitors are discharged: this shall be done in a safe manner to avoid possibility of sparking;
- that no live electrical components and wiring are exposed while charging, recovering or purging the system;
- that there is continuity of earth bonding.

**During repairs to sealed components, all electrical supplies shall be disconnected from the equipment being worked upon prior to any removal of sealed covers, etc. If it is absolutely necessary to have an electrical supply to equipment during servicing, then a permanently operating form of leak detection shall be located at the most critical point to warn of a potentially hazardous situation.**

**Particular attention shall be paid to the following to ensure that by working on electrical components, the casing is not altered in such a way that the level of protection is affected. This shall include damage to cables, excessive number of connections, terminals not made to original specification, damage to seals, incorrect fitting of glands, etc.**

**Ensure that seals or sealing materials have not degraded such that they no longer serve the purpose of preventing the ingress of flammable atmospheres.**

**Replacement parts shall be in accordance with the manufacturer's specifications.**

**Do not apply any permanent inductive or capacitance loads to the circuit without ensuring that this will not exceed the permissible voltage and current permitted for the equipment in use.**

**Intrinsically safe components are the only types that can be worked on while live in the presence of a flammable atmosphere. The test apparatus shall be at the correct rating.**

**Replace components only with parts specified by the manufacturer. Other parts may result in the ignition of refrigerant in the atmosphere from a leak.**

**Check that cabling will not be subject to wear, corrosion, excessive pressure, vibration, sharp edges or any other adverse environmental effects. The check shall also take into account the effects of ageing or continual vibration from sources such as compressors or fans.**

**When breaking into the refrigerant circuit to make repairs – or for any other purpose – conventional procedures shall be used. However, it is important that best practice is followed.**

**Since flammability is a consideration. The following procedure shall be adhered to:**

- remove refrigerant;
- purge the circuit with inert gas;
- evacuate;
- purge again with inert gas;

- open the circuit by cutting or brazing.

The refrigerant charge shall be recovered into the correct recovery cylinders. The system shall be “flushed” with OFN to render the unit safe. This process may need to be repeated several times. Compressed air or oxygen shall not be used for this task.

Flushing shall be achieved by breaking the vacuum in the system with OFN and continuing to fill until the working pressure is achieved, then venting to atmosphere, and finally pulling down to a vacuum.

This process shall be repeated until no refrigerant is within the system. When the final OFN charge is used, the system shall be vented down to atmospheric pressure to enable work to take place.

This operation is absolutely vital if brazing operations on the pipe-work are to take place.

Ensure that the outlet for the vacuum pump is not close to any ignition sources and there is ventilation available.

Ensure that contamination of different refrigerants does not occur when using charging equipment. Hoses or lines shall be as short as possible to minimise the amount of refrigerant contained in them.

Prior to recharging the system it shall be pressure tested with OFN.

#### DD.12 Decommissioning:

Before carrying out this procedure, it is essential that the technician is completely familiar with the equipment and all its detail. It is recommended good practice that all refrigerants are recovered safely. Prior to the task being carried out, an oil and refrigerant sample shall be taken in case analysis is required prior to re-use of reclaimed refrigerant. It is essential that electrical power is available before the task is commenced.

- a) Become familiar with the equipment and its operation.
- b) Isolate system electrically.
- c) Before attempting the procedure ensure that:
  - *mechanical handling equipment is available, if required, for handling refrigerant cylinders;*
  - *all personal protective equipment is available and being used correctly;*
  - *the recovery process is supervised at all times by a competent person;*
  - *recovery equipment and cylinders conform to the appropriate standards.*
- d) Pump down refrigerant system, if possible.
- e) If a vacuum is not possible, make a manifold so that refrigerant can be removed from various parts of the system.
- f) Make sure that cylinder is situated on the scales before recovery takes place.
- g) Start the recovery machine and operate in accordance with manufacturer's instructions.
- h) Do not overfill cylinders. (No more than 80 % volume liquid charge).
- i) Do not exceed the maximum working pressure of the cylinder, even temporarily.
- j) When the cylinders have been filled correctly and the process completed, make sure that the cylinders and the equipment are removed from site promptly and all isolation valves on the equipment are closed off.
- k) Recovered refrigerant shall not be charged into another refrigeration system unless it has been cleaned and checked.

Equipment shall be labelled stating that it has been de-commissioned and emptied of refrigerant. The label shall be dated and signed. Ensure that there are labels on the equipment stating the equipment contains flammable refrigerant.

When removing refrigerant from a system, either for servicing or decommissioning, it is recommended good practice that all refrigerants are removed safely.

When transferring refrigerant into cylinders, ensure that only appropriate refrigerant recovery cylinders are employed. Ensure that the correct number of cylinders for holding the total system charge are available. All cylinders to be used are designated for the recovered refrigerant and labelled for that refrigerant (i.e. special cylinders for the recovery of refrigerant). Cylinders shall be complete with pressure relief valve and associated shut-off valves in good working order. Empty recovery cylinders are evacuated and, if possible, cooled before recovery occurs.

The recovery equipment shall be in good working order with a set of instructions concerning the equipment that is at hand and shall be suitable for the recovery of flammable refrigerants. In addition, a set of calibrated weighing scales shall be available and in good working order. Hoses shall be complete with leak-free disconnect couplings and in good condition. Before using the recovery machine, check that it is in satisfactory working order, has been properly maintained and that any associated electrical components are sealed to prevent ignition in the event of a refrigerant release. Consult manufacturer if in doubt.

The recovered refrigerant shall be returned to the refrigerant supplier in the correct recovery cylinder, and the relevant Waste Transfer Note arranged. Do not mix refrigerants in recovery units and especially not in cylinders.

If compressors or compressor oils are to be removed, ensure that they have been evacuated to an acceptable level to make certain that flammable refrigerant does not remain within the lubricant. The evacuation process shall be carried out prior to returning the compressor to the suppliers. Only electric heating to the compressor body shall be employed to accelerate this process. When oil is drained from a system, it shall be carried out safely.

**Warning:** disconnect the appliance from its power source during service and when replacing parts.

These units are partial unit air conditioners, complying with partial unit requirements of this International Standard, and must only be connected to other units that have been confirmed as complying to corresponding partial unit requirements of this International Standard.

# OPERATING INSTRUCTIONS

## 1 Precautions for Use

### [ Warning ]

Please turn off the main power switch if the unit is not used for a long time; otherwise, an accident may occur.

The air conditioner shall be installed at least 2.5m above the ground to prevent the risks below:

1. Do not touch the moving or live parts (rotors, motors, wind deflectors, etc.); otherwise, they may cause injury to you or damage to transmission parts.
2. You may not feel that comfortable if staying too close to the air conditioner.

When it is used with a combustion appliance, regular ventilation is required; otherwise, an insufficient oxygen supply may occur.

Do not allow children to play with the air conditioner; otherwise, a danger may occur.

Do not expose the indoor unit and controller to water and moisture; otherwise, a short circuit or even fire may occur.

Do not place the combustion appliance in the direct air supply position of the air conditioner; otherwise, incomplete combustion of the combustion appliance may occur.

Do not use or store flammable gases or liquids such as natural gas, hair gel, paint and gasoline near the air conditioner; otherwise, fire may occur.

Do not put animals and plants in the direct air supply of the air conditioner, so as not to cause harm to them.

In case of abnormal conditions, such as abnormal noise, smell, smoke, temperature rise, and leakage of electricity, please cut off the power supply immediately, and then contact the local dealer or air conditioner customer service center. Do not repair the air conditioner by yourself.

Do not place the combustible sprayer near the air conditioner or spray it directly to the air conditioner; otherwise, fire may occur.

Do not place the water container on the air conditioner. The water immersed in the air conditioner will weaken the insulation and cause electric shock.

After long-term use, please confirm whether the installation platform is worn. If placed on a worn platform, the air conditioner may fall and cause casualties.

Do not operate the switch with wet hands, which may cause electric shock.

During maintenance, please stop the air conditioner and cut off the power supply; otherwise, the high-speed operation of the rotors will cause injury.

It cannot be used to preserve food, animals and plants, precise instruments and artworks, which will lead to quality degradation.

Do not use fuses beyond the specified capacity in the manual. For example, iron wires and copper wires will lead to failure, fire and other consequences. The power supply used must be a dedicated one for the air conditioner within the allowable voltage range.

Do not place any valuables under the air conditioner, since the air conditioner may produce condensed water under some failure conditions, which will cause damage to the valuables below.

**Disposal:** Do not dispose of this product as unsorted municipal waste. Collection of such waste separately for special treatment is necessary.

Do not dispose of electrical appliances as unsorted municipal waste, use separate collection facilities. Contact your local government for information regarding the collection systems available.

If electrical appliances are disposed of in landfills or dumps, hazardous substances can leak into the groundwater and get into the food chain, damaging your health and well-being.

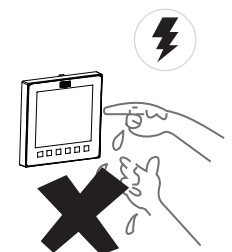
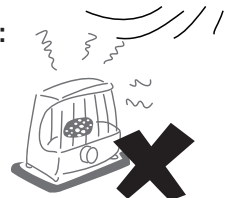

## [Caution]

To use the unit normally, please follow the Operating Instructions herein; Otherwise, internal protection or dripping of the unit may occur, or the cooling and heating effect may be reduced. Please ensure that the room temperature is set properly, especially when there are old people, children or patients in the room.

Lightning or the start and stop of large electrical equipment in nearby factories may cause wrong operation of the air conditioner. Please turn off the main power switch for several seconds and turn it on, and then restart the air conditioner.

To avoid the danger caused by the wrong reset of the thermal circuit breaker, the air conditioner shall not be supplied by the external switching device, such as a timer or a circuit that is switched on and off at regular intervals by a general-purpose component.

Check whether the air filter is properly installed, and ensure that the air inlet and outlet of the indoor and outdoor units are not blocked. If the air conditioner has not been used for a long time, please be sure to clean the air filter before starting the air conditioner. Otherwise, the dust and mold on the filter screen will cause air pollution or peculiar smell. Please refer to the chapter "Cleaning and Maintenance" for details.

When using the air conditioner or replacing the filter screen for the first time, please set the controller by following the steps below:

- ① Reset the initial static pressure on the controller, or test run the outdoor unit once (done by the installer); set the current state as the reference state in which the filter screen is determined to be dirty and blocked. (For details, see the chapter "Application Control" in the installation section )
- ② Set the difference between the initial and final resistance of the filter screen. (See the instructions of wire controller for details)

If the operations above are not performed, the machine may not detect the dirt and blockage of the filter screen accurately.

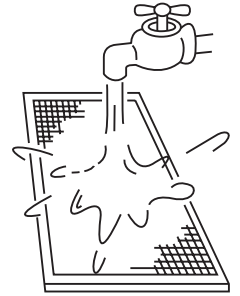
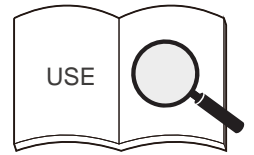

## 2 Optimal Operation Mode

According to the characteristics of cold air sinking and hot air rising, it is suggested that the air outlet direction of the air deflector should be adjusted respectively during cooling and heating to improve the effect of cooling and heating.

When the components at the air outlet (sold separately) are used, it is recommended to make adjustments as follows.

### Cooling

It is recommended to adjust horizontally the wind deflector of the air outlet grille to achieve a good cooling effect in the whole room.

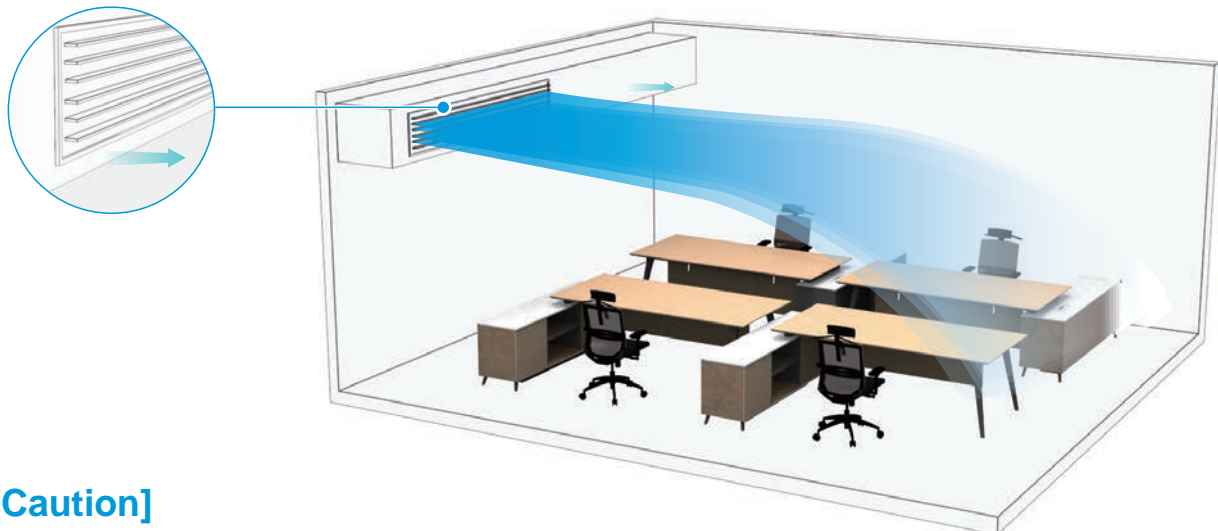

## [Caution]

If cooling works with the air outlet facing downwards, condensation may occur on the surface of the air outlet and the wind deflector.

## Heating

It is recommended to adjust downward the wind deflector of the air outlet grille to achieve a good heating effect on the bottom floor of the room.

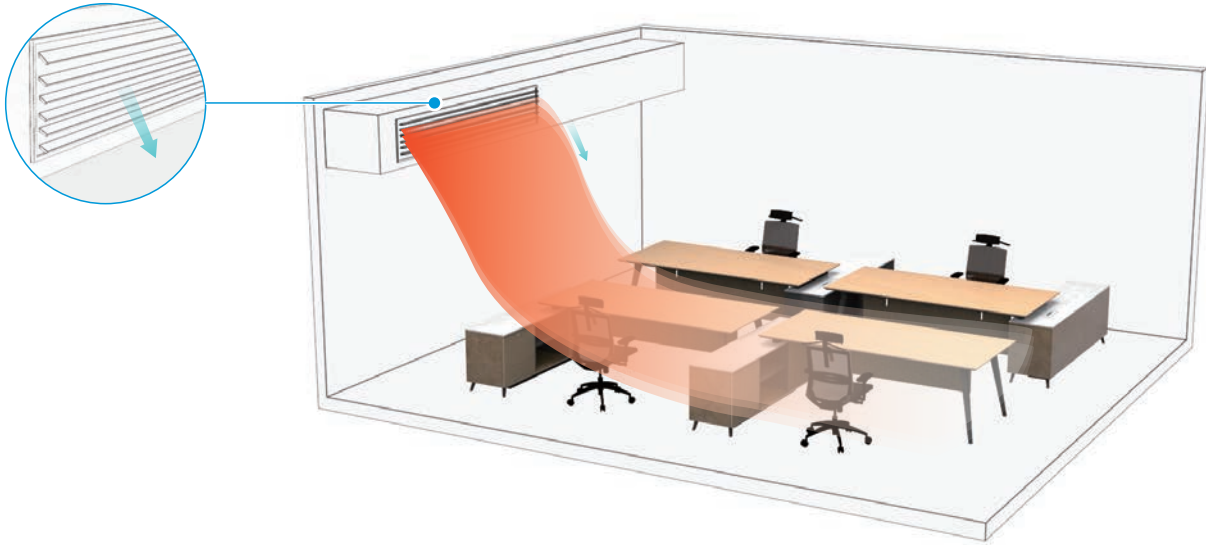

## Product operation scope

Please turn on the air conditioner under the temperature conditions below to maintain good performance:

Cooling	Indoor temperature	16~30°C
	Indoor humidity	≤ 80% (When the humidity exceeds 80%, dew may condense on the surface of the indoor unit or vaporific cold air may be blown out from the air outlet if it works for a long time)
Heating	Indoor temperature	16~30°C

### [Caution]

The indoor unit operates stably within the temperature range given in the above table. If the normal operating range is exceeded, the indoor unit may stop working and display an error code.

# 3 Non-air Conditioner Fault

## Normal protection of air conditioner

In case of the following phenomena during your use of the air conditioner, it is normal and no maintenance is required.

### Protection Function

When the power switch is turned on, start the system immediately after it stops running, and the outdoor unit will stop working after about 4 minutes as the compressor cannot be shut down and started frequently, which is a normal phenomenon of the machine.

### Cold air prevention function (cooling & heating)

In the heating mode (including heating in automatic mode), if the indoor heat exchanger does not reach a certain temperature, it is necessary to wait for the temperature of the heat exchanger to rise, and the indoor fan shall temporarily stop running or run at a low wind speed to prevent the cold air from blowing out.

### Defrosting Operation

(cooling & heating)

In case of low outdoor temperature and high humidity, the heat exchanger of the outdoor unit may be covered with frost, which will reduce the heating capacity of the air conditioner. In this case, the air conditioner will stop heating and defrost automatically, and resume heating after defrosting. During defrosting, the outdoor fan stops working and the indoor fan works according to the function of cold air prevention. According to the outdoor temperature and frosting condition, the defrosting operation time varies, generally 2~10 minutes. During the defrosting process, the outdoor unit may emit steam, which is caused by rapid defrosting and is a normal phenomenon.

### Anti-condensation function

The indoor unit detects the operating environment. When the humidity is judged to be very high, the air conditioner will prevent the formation of condensation water by adjusting the angle of the wind deflector and the fan speed to avoid dripping. (This function is not available, if a third-party panel is selected)

## Normal phenomenon rather than air conditioner fault

In case of the following phenomena during the use of the air conditioner, they are normal and can be removed by following the steps below or no measures are required.

### ■ The indoor unit gives off white mist

- ① In an environment with high indoor relative humidity, white mist may appear when "Cooling" works due to high humidity and large temperature difference between inlet and outlet.
- ② When the air conditioner is switched to "heating" after "defrosting", the moisture produced by defrosting the indoor unit is discharged as steam.

### ■ Dust is blown out from the indoor unit

If it is not used for a long time or for the first time, it is recommended to clean the filter screen; otherwise, the dust entering the indoor unit will be blown out.

### ■ Peculiar smell from the indoor unit

The indoor unit absorbs the smell of rooms, furniture or cigarettes, etc., and sends them out during operation. Therefore, it is recommended to have cleaning and maintenance by professional personnel on a regular basis.

### ■ There are water drops on the surface of the air conditioner

There may be water drops or slight water blowing on the surface of the air conditioner when the indoor relative humidity is high, which is normal. Please close the doors and windows.

### ■ "Self-cleaning" icing sound

After the air conditioner enters the self-cleaning stage, there may be a slight "click" sound for about 10 minutes, indicating that the indoor unit is freezing, which is normal.

### ■ Low noise of air conditioner

- ① When the air conditioner works under "Automatic", "Cooling", "Dehumidification" and "Heating" modes, there may be a low continuous "fizz" sound from it, which is the sound of refrigerant flowing between the indoor unit and the outdoor unit.
- ② A "fizz" may be heard for a short time after the air conditioner stops or during "defrosting", which is the sound made when the refrigerant stops flowing or the flow rate is changed.
- ③ When the air conditioner works in "Cooling" or "Dehumidification" mode, a low continuous "fizz" sound may be heard, which is the sound of a draining pump running.
- ④ When the air conditioner just starts or stops running, a "squeak" and "clopping" sound may be heard, which is caused by thermal expansion and cold shrinkage of parts or surrounding decoration materials. Such a sound will disappear during normal operation.

### ■ "Cooling"/"Heating" (not available for a unit with cooling function only) mode is switched to only air supply mode during operation

The compressor of the air conditioner controller will automatically stop the operation of the compressor and switch to the air supply mode only when the indoor unit reaches the set temperature. When the room temperature rises (in "Cooling" mode) or falls (in "Heating" mode) to a certain extent, the compressor will be restarted to resume the cooling or heating.

### ■ The heating effect may be reduced when the outdoor temperature is very low in winter

- ① When the cooling and heating air conditioner works in the "Heating" mode, the air conditioner absorbs heat from the outdoor air and releases it indoors to heat the room air, which is the heating principle of the heat pump of the air conditioner.
- ② When the heat pump works, the outdoor unit blows cold air, and the outdoor temperature drops. When the outdoor temperature is very low, the heating capacity will decrease gradually. It is recommended to use other heating devices for heating together.

### ■ Mode conflict

For the same air conditioning system, the indoor unit can only work in cooling, heating or other modes at the same time. When the operation modes of multiple indoor units are inconsistent, a mode conflict will be caused. It is necessary to ensure that the operating mode of all indoor units is consistent.

### ■ No hot and cold options

For the same set of air conditioning system, when the outside unit is changed over to the priority mode, the mode supported by the indoor unit can be selected for the main wire controller. The wire controller of the non-main indoor unit displays the icon of "No hot and cold options". The mode setting is unavailable and is the same as the operation mode of the main indoor unit.

# INSTALLATION INSTRUCTIONS

Please read this instructions carefully before installing the indoor unit

## 1 Precautions for Installation

### Qualification and Safety Regulation Requirements

#### [ Warning ]

**Please install the unit according to national standards.**

**Please commission the installation of the unit to a dealer or a professional technician.**

The unit must be installed by professional and technical personnel, who must have relevant professional knowledge. Users are not allowed to install the air conditioner by themselves. Otherwise, incorrect operation will cause fire, electric shock, injury, water leakage, etc., which may cause injury to you or others or damage the air conditioner.

**Do not perform modifications or repairs by yourself.**

Improper repair may cause fire, electric shock, injury, water leakage and other accidents. Be sure to entrust a dealer or a professional to repair it.

**Verify whether an earth leakage circuit-breaker is installed.**

An earth leakage circuit-breaker must be installed; otherwise, electric shock may occur.

**Local electrical company regulations shall be followed for power connection.**

Reliable grounding must be carried out according to the law. Incomplete grounding may cause an electric shock.

**Please entrust a dealer or professional to move, remove or install the air conditioner. Improper installation will result in fire, electric shock, injury, water leakage and other accidents.**

**Be sure to use our designated products for optional parts and additional parts for sale.**

When installing optional parts and additional parts for sale, please use our designated optional parts and entrust professionals to install them. Improper installation may cause fire, electric shock, water leakage and other hazards.

**Use power cables and communication cables of specified specifications, and ensure that all wiring is properly connected to prevent the wiring terminals, power cables and communication cables from being pulled by external forces. Poor wiring or improper installation can cause a fire.**

**The air conditioner must be grounded. Check whether grounding cables are reliably connected or broken. Do not connect grounding cables to gas tanks, water pipes, lightning rods and telephone grounding cables.**

**The main power switch of the air conditioner shall be set at a position out of reach of children.**

Prevent children from playing with the main power switch to cause danger, and do not cover the main power switch with curtains and other inflammables.

**When refrigerant leaks, there shall be no smoke and fire.**

If the air conditioner fails to work normally in "Cooling" or "Heating" mode, there may be refrigerant leakage. In this case, contact the dealer or professional personnel. The refrigerant used in the air conditioner is safe and usually does not leak.

In case of indoor leakage of refrigerant, it is easy to cause fire after contact with the smoke or fire of heater/electric furnace/stove. Please first turn off the power switch of the air conditioner, extinguish the fire of the burner and open the door and window of the room for ventilation to ensure that the concentration of refrigerant leakage in the room does not exceed the critical level. Then, stay away from the leakage point, and contact the dealer or professionals in time.

**Please turn on the air conditioner after confirming that the maintenance personnel have repaired it for refrigerant leakage.**

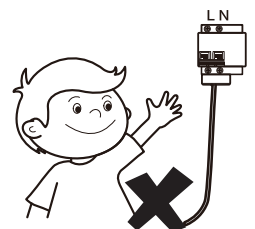
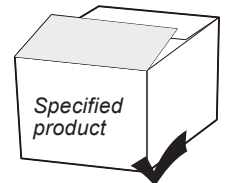
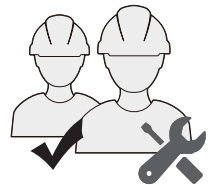

Exposure of the unit to water or other moisture before or after installation may cause a short circuit of electrical components. Do not store it in a wet basement or expose it to rain or water.

**Confirm whether the installation foundation and hoisting are secure and reliable.**

Poor installation of the subbottom may cause the air conditioner to fall and cause accidents. The influence of strong wind, typhoon, and earthquake shall be fully considered for reinforcement and installation.

**Verify that drain pipes can drain smoothly.**

Improper pipe installation will cause water leakage, wet furniture and electrical appliances, damage carpets, etc.

**After installation, check whether the refrigerant leaks.**

**Do not install the pipe in places with potential leakage of flammable gas.**

In case of leakage of combustible gas, it is easy to cause fire if it stays around the indoor unit.

**Ensure that the air filter with the mesh number ranging between 30 and 80 (per inch) is installed at the return air grille of the air conditioner to filter the fine dust in the air and keep the air duct clean and prevent it from being polluted and blocked.**



### [ WARNING for Using R32 Refrigerant ]

When flammable refrigerant are employed, appliance shall be stored in a well -ventilated area where the room size corresponds to the room area as specific for operation.

For R32 frigerant models:

Appliance shall be installed, operated and stored in a room with a floor area larger than  $X \text{ m}^2$  .

Appliance shall not be installed in an unvertilated space, if that space is smaller than  $X \text{ m}^2$ .

When using R32 refrigerant, the applicable room area must be greater than or equal to the minimum applicable room area. For the minimum applicable room area, please refer to the manual of the outdoor unit.

Reusable mechanical connectors and flared joints are not allowed indoors.(EN Standard Requirements). When mechanical connectors are reused indoors, sealing parts shall be renewed. When flared joints are reused indoors, the flare part shall be re-fabricated. (IEC Standard Requirements)

Mechanical connectors used indoors shall comply with ISO 14903.

### [ Caution ]

Indoor units, outdoor units, power cables and connecting wires shall be at least 1m away from high-power radio equipment to prevent electromagnetic wave interference and noise. (The electromagnetic waves in some bands are not sufficient to prevent noise even if they are more than 1 m away from each other.)

In rooms with fluorescent lamps (rectifying or quick-start type), the signal transmission distance of the remote controller (wireless) may not reach the predetermined value. The indoor unit should be installed as far away from the fluorescent lamp as possible.

**Do not touch the fins of the heat exchanger. Improper touching may cause cutting.**

**For safety reasons, please handle the packed materials properly.**

Nails and other packing materials may cause personal injury or other injuries. Please tear the plastic bag and dispose of it properly to prevent children from suffocating by playing with it.

**Do not cut off the power supply immediately when the indoor unit stops working.**

**After changing the air inlet and outlet panels or the length and direction of the connecting air duct, please make the following settings on the controller before using the air conditioner next time: (For details, see the chapter "Application Control" in the installation section)**

Reset the initial static pressure on the controller, or test run the outdoor unit once (done by the installer); set the current state as the reference state in which the filter screen is determined to be dirty and blocked.

**If the operations above are not performed, the machine may not detect the dirt and blockage of the filter screen accurately.**









## Precautions for handling and lifting

- ① Before the handling, please confirm the handling route of the air conditioning unit to the installation location.
- ② Do not unpack the air conditioner until it has been moved to the installation site.
- ③ When unpacking and moving the air conditioner, hold the hanger seat and do not apply force to other parts, especially to refrigerant piping, drainage pipes and plastic accessories, so as not to damage the air conditioner and cause personal injury.
- ④ Before installing the air conditioner, please check whether the refrigerant specified on the nameplate has been used. For details about the installation of outdoor unit, see the installation instructions in the accompanying installation and operation manual of the outdoor unit.

## Prohibited places for installation

### [Warning]

#### Do not install or operate the air conditioner in the following places:

-  Places filled with mineral oil or oil fume or mist, such as kitchens.  
The plastic parts will be aged, and the heat exchanger will get dirty and blocked, eventually leading to poor cooling and heating effect, water leakage or other problems of the air conditioner.
-  Places where corrosive gases such as acid and alkaline gases are present.  
Copper pipes and solder joints will corrode, eventually causing refrigerant leakage.
-  Places exposed to flammable gases and places where volatile flammable gases such as thinner and gasoline are used.  
The electronics in the air conditioner may cause the surrounding gases to ignite.
-  Places where machines producing electromagnetic radiation are present.  
The control system will fail, and the air conditioner will not function properly.
-  Places with high levels of salt in the air, such as seashores.
-  Do not use the air conditioner in places where explosions may occur.
-  Places such as in the compartments of vehicles, ships, etc.
-  Places such as factories with severe power supply voltage fluctuations.
-  Places under other special environmental conditions.







### [Tips]

This series of air conditioners are used for comfort air conditioning, and must not be used in computer rooms and special places for storing precision instruments, food, animals, plants, artworks, etc.

## Suggestions on selection of installation location

**It is recommended that construction be carried out based on the design drawings of HVAC engineers. Select the installation location based on the following principles:**

-  Ensure that the air flow in and out of the indoor unit is organized reasonably and that indoor air circulation is formed.
-  Guarantee the space for overhaul and maintenance of indoor unit.
-  The closer the drainage pipes and copper pipes are to the outdoor unit, the lower the cost of pipes required for construction is.
-  Prevent the air from the air conditioner from blowing directly onto the human body.

- ✓ The closer the wires are to the power supply cabinet, the lower the cost of wires is.
- ✓ Keep the return air of the air conditioner away from direct sunlight in the room.
- ✓ Do not interfere with light troughs, fire mains, gas pipelines and other facilities.
- ✓ Do not install the indoor unit on load-bearing beams, columns, or in other locations where the safety of the building structure will be affected.
- ✓ Install the wire controller and the indoor unit in the same installation place. Otherwise, the sampling point setting of the wire controller needs to be changed.

**Select the location that fully meets the following conditions and user requirements to install the air conditioner:**

- ✓ Adequate space for installation and maintenance shall be provided. (See the figure on the right)
- ✓ The ceiling shall be level and the building construction shall be strong enough to bear the weight of the indoor unit. Reinforcement measures shall be taken if necessary.
- ✓ The inlet and outlet air shall be free and least affected by outside air.
- ✓ The supply air can be spread to any position in the room.
- ✓ The connecting pipes and drainage pipes shall be easy to lead out.
- ✓ There shall be no direct radiation from heat sources.
- ✓ It shall be avoided to install the air conditioner in a narrow space with high noise requirements.
- ✓ The indoor unit shall be installed at a position greater than 2.5m above the ground.
- ✓ The condensed water can be drained smoothly.
- ✓ The length of piping between indoor and outdoor units shall be within the allowable range. (See the installation and operation manual of outdoor unit.)

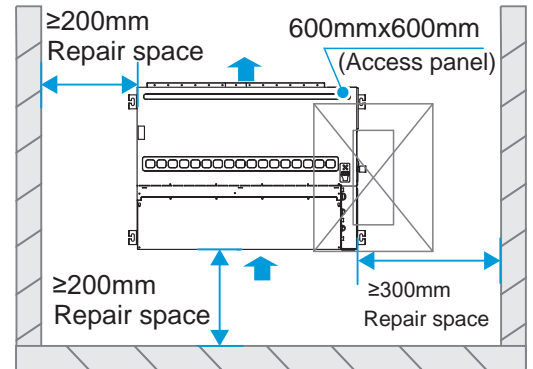

**Suggestions on selection of installation location**



**Living room, office and other crowded places**

Generally, a concealed arrangement and the air supply mode of "side air supply and lower air return" shall be adopted.

In terms of installation position, the air outlet cannot be directed to positions with people, such as sofas and tea tables. The air shall be supplied from the side to improve comfort, because direct blowing will cause discomfort to the human body.



**Dining room**

Since the dining room is generally adjacent to the kitchen and there is heavy cooking oil fume in the kitchen, the central air conditioner could be installed on the ceiling of the passage between the dining room and the kitchen. The air outlet shall not face the dining table, because it is inevitable that dust will be adsorbed at the air outlet on the ceiling, so as to avoid blowing dust into the food when air is coming out of the air outlet and affecting food hygiene. The return air inlet shall be kept away from the kitchen as far as possible to avoid inhalation of cooking oil fume and affecting air quality.



**Bedroom**

The air conditioner can be installed on the suspended ceiling above the bedroom door, or near the window. The flexible air supply mode of "side air supply and lower air return" shall be adopted. In terms of installation position, avoid blowing air directly onto the bed as far as possible.

# Product Size

(Unit: mm)

Appearance and size of air outlet and fresh air outlet:

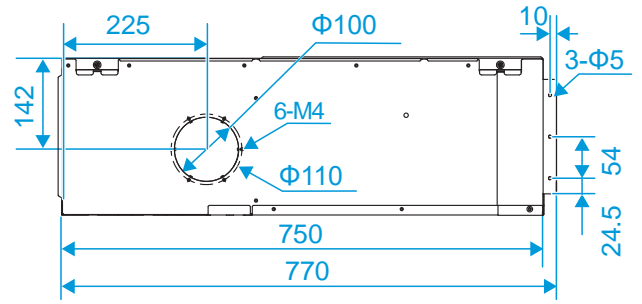
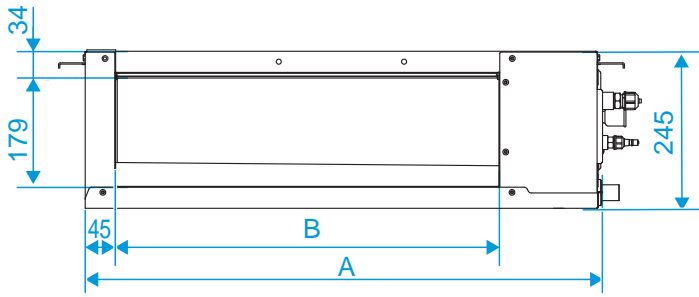

Size of return air inlet (rear air return mode):

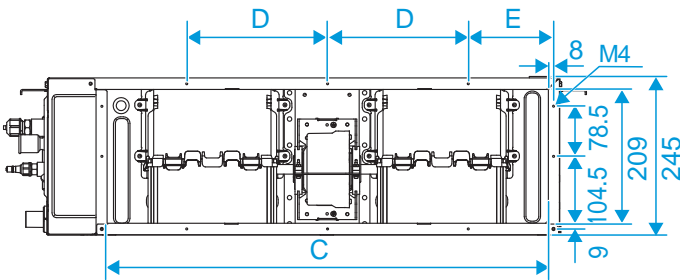

Piping and water pipe size:

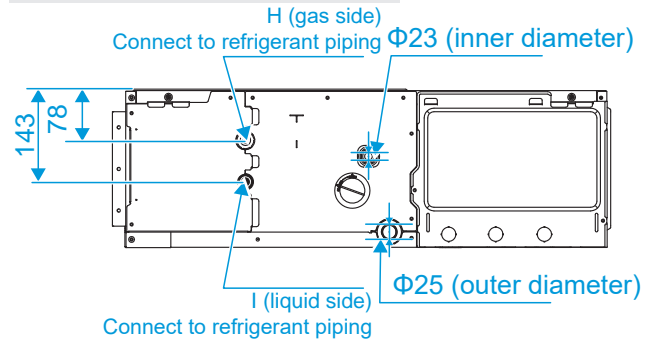

Size of return air inlet (lower air return mode) and distance between lifting lugs:

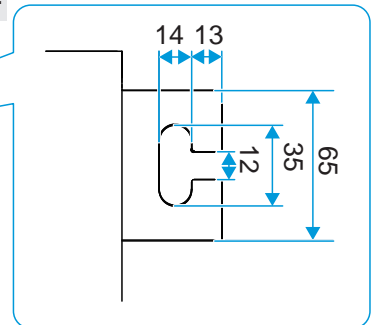
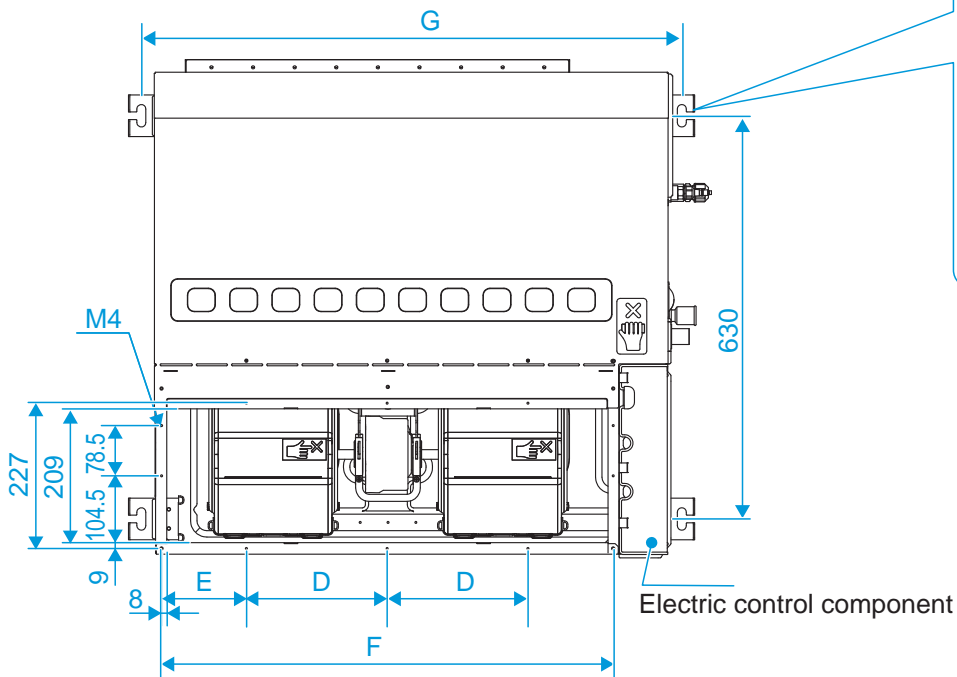

Model	A	B	C	D	E	F	G	H	I
15~45	600	400	490	87.5	165	506	645	φ12.7	φ6.35
56	800	600	690	220	134	706	845	φ12.7	φ6.35
71	800	600	690	220	134	706	845	φ15.9	φ9.52
80~90	1050	850	940	220	146	956	1095	φ15.9	φ9.52
112~160	1400	1200	1290	220	213	1306	1445	φ15.9	φ9.52

# 2 Installation material

## Product accessories

### List of accessories

<b>Installation and Operation Manual</b> X 1 Installation and Operation Manual of indoor unit (Please be sure to provide it for the user)	<b>Copper nut</b> X 2 Used for the engineering installation of connecting pipe (The number of models with process pipes is 1)	<b>Drainage pipe</b> X1 N/A for models with drainage pumps	<b>Tie</b> X4 Used to tighten the connections between the drain hose and the indoor unit outlet and PVC water pipe	<b>Insulation pipe</b> X2 Thermal insulation and anti-condensation effect of piping connections
<b>Installation spring</b> X2 Installation display components (for some models)	<b>Remote control (optional)</b>	<b>Wire controller (optional)</b>	<b>Display components (optional)</b>	<b>Air filter screen</b>

### [Caution]

Please cut insulation pipes as needed during on-site installation. (For installation methods, please refer to the figure (a), (b) below. Wrong method is shown in the figure (c))

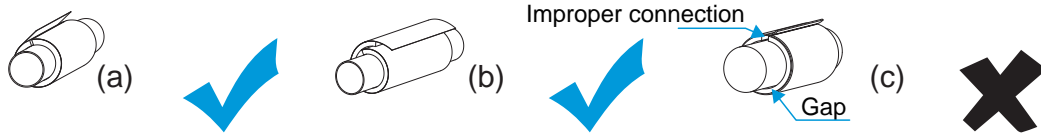

### [Tips]

Please check whether the above items are included in the accessory package. If not, please contact the dealer for handling.

Do not throw away any accessories that may be needed for installation until the installation is complete.

Customers may choose to purchase other separately sold, optional accessories, such as wire controllers, display components, and remote controllers (with seven-gear fan speed controller).

The air filter includes primary, medium and high-efficiency filter screens. For high-efficiency filter screens, please consult dealers for customization.

**Medium filter**

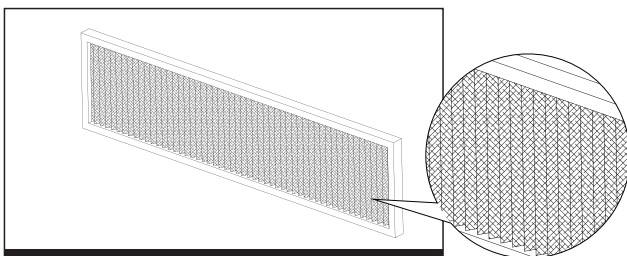

**High-efficiency filter**

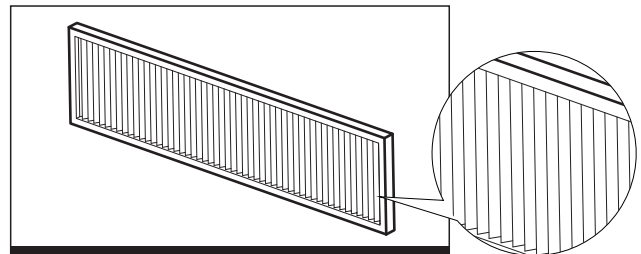

## Locally sourced accessories

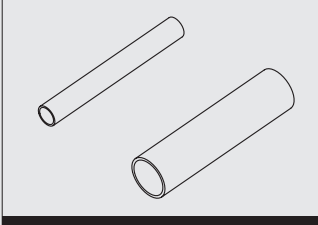
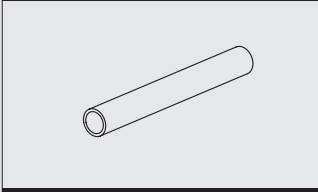
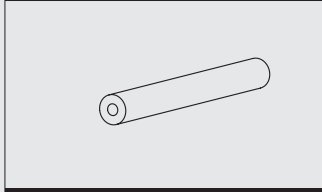
		Copper pipe (GB1527 drawn copper pipe) (unit: mm)			
		Model	Piping	Liquid side	Gas side
		15~56		φ6.35×0.75	φ12.7×0.75
		71~160		φ9.52×0.75	φ15.9×1.0
Remarks		It is used for the connection of refrigerant system of indoor unit. Soft copper pipe (T2M) is recommended, and its length shall be based on the actual situation.			
		PVC drainage pipe		Insulation pipe	
		It is used as the drainage pipe of indoor unit with an diameter of 25 mm, and its length shall be selected as needed.		The wall thickness of insulation pipe is usually more than 10 mm for copper pipes and more than 15 mm for rigid polyethylene pipe. The wall thickness shall be appropriately increased in closed wet areas.	

### [Caution]

The materials for on-site installation, such as copper pipes, air ducts, flexible hoses connecting air outlets, drainage pipes, lifting screws, air supply and return grilles, various fasteners (pipe supports, clamps, screws, etc.), power cords, and signal cables, shall be purchased by the installer on site, and the material quality and specifications must meet the relevant national or industrial standards.

## Requirements for insulation materials

### Insulation of copper pipes

- ① Closed-cell foam insulation materials with a combustion performance grade of B1 and a heat resistance of over 120°C shall be used.
- ② Wall thickness of insulation pipe:
  1. When the diameter is  $\geq 15.9$  mm, the wall thickness of the insulation pipe shall be greater than 20 mm.
  2. When the diameter is  $\leq 12.7$  mm, the wall thickness of the insulation pipe shall be greater than 15 mm.
- ③ For the system used for heating in winter in severe cold areas, the wall thickness of the insulation pipe shall be increased. For the insulation of the outdoor copper pipe part, the wall thickness of the insulation pipe is generally more than 40 mm. For the insulation of the indoor air duct part, it is recommended that the wall thickness of the insulation pipe be more than 20 mm.
- ④ The connection between insulation pipes and the cut part shall be applied with adhesive and then wrapped with electrical tape. The width of the tape shall not be less than 50mm to ensure firm connection.
- ⑤ The insulation between the copper pipe and the indoor unit shall be tight enough to prevent the generation of condensed water.
- ⑥ The insulation of copper pipes can be carried out only after it has been confirmed that there is no leakage point in the system based on the leakage inspection.

### Insulation of air ducts

- ① The insulation of air duct components and equipment shall be carried out after the air duct system has passed the air leakage test or quality inspection.
- ② Generally, centrifugal glass wool or rubber and plastic materials are used for thermal insulation, or new insulation air ducts shall be used. The insulation layer shall be flat and compact, without cracks, voids and other defects.
- ③ The supports, hangers and brackets of the air ducts shall be arranged outside the insulation layer, and skids shall be inlaid between the supports, hangers and brackets and the air ducts.
- ④ Thickness of insulation layer:
  1. For the air supply and return ducts laid in non-air-conditioned rooms, the thickness of the insulation layer shall not be less than 40 mm if centrifugal glass wool is used for insulation.
  2. For the air supply and return ducts laid in the air-conditioned rooms, the thickness of the insulation layer shall not be less than 25 mm if centrifugal glass wool is used for insulation.
  3. If rubber and plastic materials or other materials are used, the thickness of the insulation layer shall be based on the design requirements or the calculations.

### Drainage pipe insulation

- ① The indoor part of the drainage pipe shall be insulated to prevent condensation, and a protective sleeve with a thickness of more than 10 mm shall be used.
- ② If the pipe is not insulated along its whole length, the cut part must be re-bonded.
- ③ The connection between insulation pipes and the cut part shall be fixed with glue or clips and shall be located at the top of the pipeline.
- ④ The insulation of the water distribution pipe can be carried out only after it has been confirmed that there is no leakage point based on the drainage test.

# 3 Component Name

## Description of components

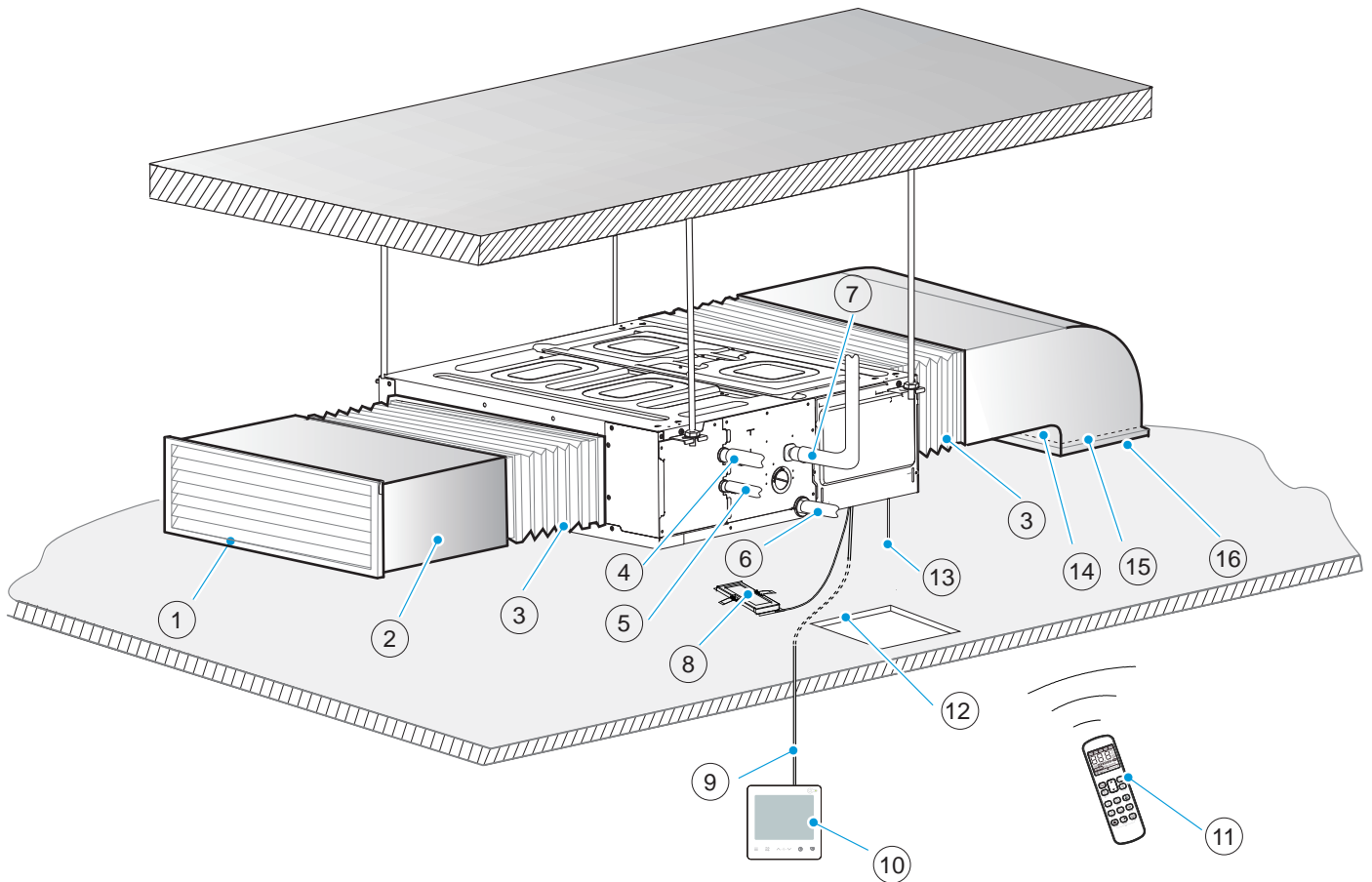

① \* Air outlet grille

② \* Air outlet duct

③ \* Flexible hose

④ Air pipe

⑤ Liquid pipe

⑥ Drainage pipe without pump

⑦ Drainage pipe with pump

⑧ Display components (optional)

⑨ \*Connecting wire

⑩ Wire controller (optional)

⑪ Remote control (optional)

⑫ Access panel

⑬ \* Power supply and ground wire

⑭ \*Return air duct

⑮ Air filter screen

⑯ \* Return air grille

\*\*\* indicates the accessory is purchased on site.

### [Tips]

All parts selected or sold separately shall be our accessories.

Please refer to the product manual for optional accessories such as wire controller.

All illustrations herein are for the purpose of explanation only, so their appearance and functions may not be completely consistent with those of the products you purchased, and the actual model shall prevail.

# 4 Preparation Before Installation

## Unpacking inspection

- ① Before installation, carry out unpacking inspection to confirm whether the packaging materials are in good condition, whether the accessories included in the package are complete, whether the appearance of the air conditioner is intact, and whether the surfaces of parts, such as the heat exchanger, are worn. At the same time, check whether there are oil stains on the stop valve of the unit.
- ② Check the two sealing nuts of the refrigerant pipe, and observe whether the red dot on the surface of the air duct sealing nut protrudes. If it protrudes, it indicates that the pipeline of the machine is well sealed; if it is dented, it indicates that the pipeline leaks. In the latter case, please contact the dealer.
- ③ Be sure to check the model of the machine before installation.
- ④ After the inspection of both indoor and outdoor units is completed, pack them in plastic bags to prevent foreign objects from entering the unit.

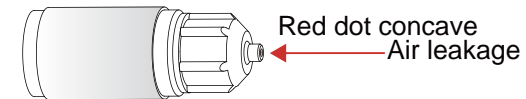
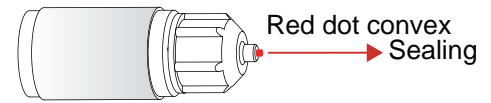

## Positioning of indoor unit

Please confirm the positional relationship between the air conditioning unit and the lifting screw.

- ① The air outlet and return mode of the indoor unit and its lifting position shall be determined according to the design drawings.
- ② A line shall be drawn to locate the drilling position of the suspender bolt according to the three-dimensional drawing of the unit.
- ③ An access hole shall be provided on the side of the electric control box (recommended size: 600 x 600 mm).
- ④ In order to facilitate the removal of the motor, the rear end of the indoor unit shall be at least 200 mm away from the wall.
- ⑤ There shall be no obstacles within 200 mm of the return air inlet.
- ⑥ Infrared level is recommended for line drawing and positioning.

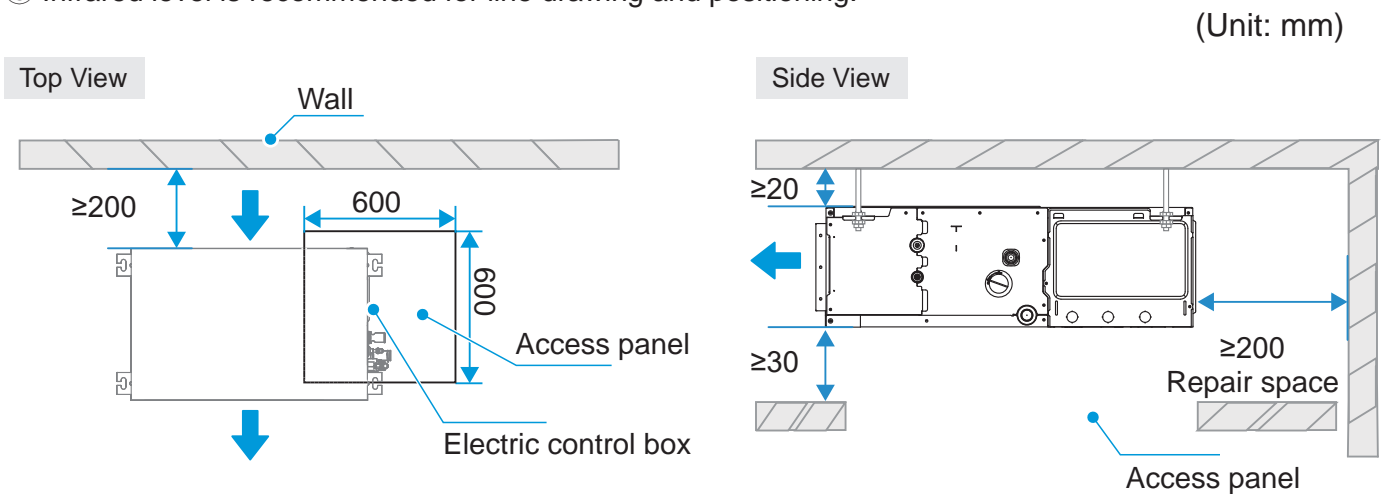

## Installation of the filter

Remove the fixing screws of the filter screen according to the drawing, and install the filter screen on the outside of the return air duct. As shown in the "Parts Description" section.

When installing the filter, please fix the filter fixing hole with screws.

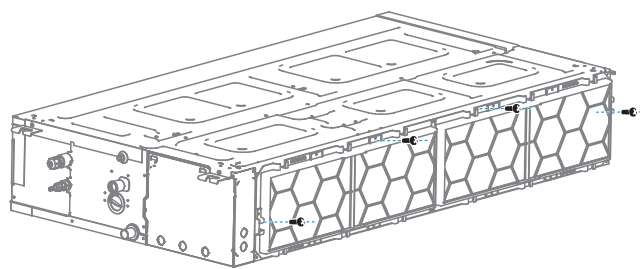

## Take out the packaging materials in the volute (for models 15~45, 112~160 only)

Please remove the packaging material before installation. See the figure below for the operation method

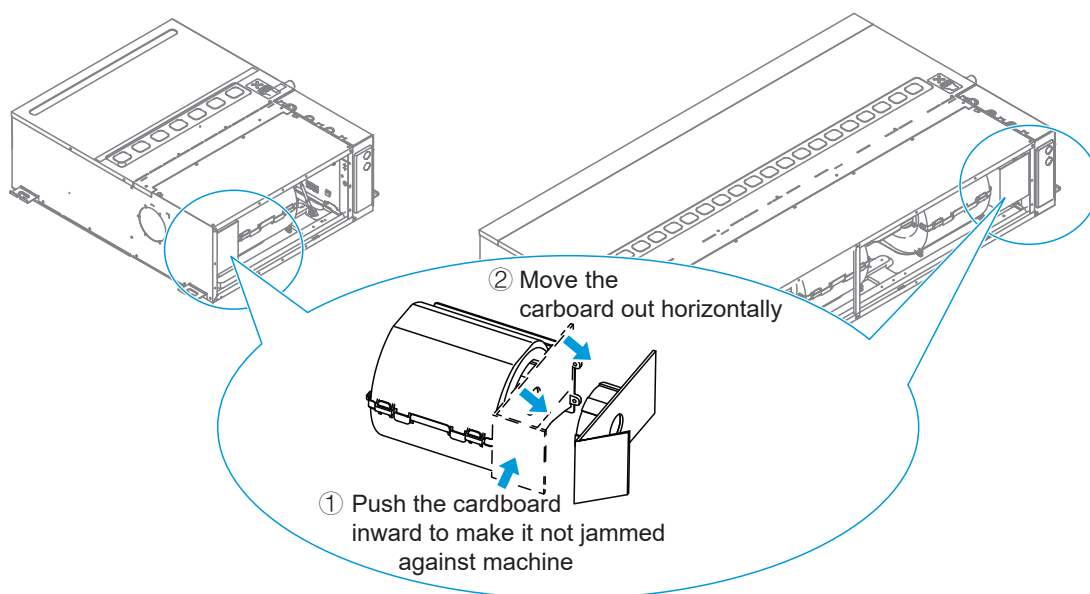

## On-site adjustment of return air box

This series of air conditioners have two air return modes:

- ① Rear return air mode: factory default;
- ② The lower return air mode can be customized, and can also be adjusted on site. See the following two diagrams for the adjustment method:

### Removal of rear cover plate assembly

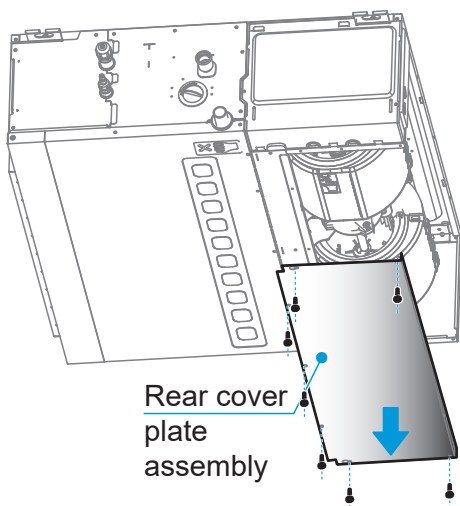

### Installation of rear cover plate assembly

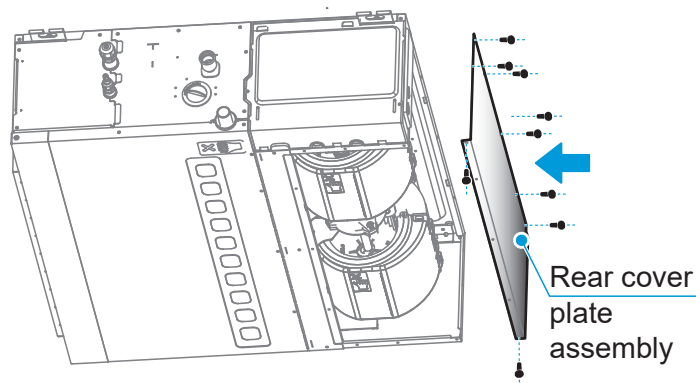

# 5 Installation of Indoor Units

## [Warning]

The air conditioner shall be installed at a location with sufficient strength to support the weight of the unit, and reinforcement measures shall be taken if necessary.

If the strength is insufficient, the unit may fall and cause personal injury.

Poor installation will cause the unit to fall and cause an accident.

Before routing the wires/pipes, make sure that the installation area (wall, floor, etc.) is safe and free of hidden dangers such as water, electricity and gas hazards.

## Installation of lifting bolts

- ① According to the distance between the four lifting holes of the indoor unit, use a pencil to draw the positions of the fixing screws on the ceiling for lifting the indoor unit. After drilling, tighten the processed expansion screw (the screw is a 490 mm long full-thread bolt welded on the  $\phi 8$  mm expansion screw. Then place it with 2 nuts into the hole), and then place the four corners of the indoor unit into the bolts to lift the indoor unit.
- ② Four suspenders shall be used for lifting, and the diameter of lifting bolts shall not be less than 10mm. The suspender must be strong enough to bear twice the weight of the indoor unit, and the lower part of the suspender shall be locked with double nuts.
- ③ If the boom length exceeds 1.5m, two diagonal braces must be added at the diagonal line to prevent shaking.
- ④ Removal of ceiling: Please consult with the interior decorator of the building for specific measures for different building structures.
  - a. Treatment of ceiling: The ceiling base frame must be strengthened in order to ensure ceiling levelness and prevent the ceiling from vibrating.
  - b. Cut and remove the ceiling base frame.
  - c. Reinforce the end faces left after the ceiling is removed, and further reinforce the base frame securing both ends of the ceiling.
  - d. After the main body is lifted, carry out piping and wiring operations in the ceiling, and determine the leading-out direction of piping after the installation location is selected.

Especially in the case of existing ceilings, please pull the refrigerant piping, drainage pipes, indoor and outdoor connecting wire, and wire controller wires to the connection positions before lifting the unit.

## [Caution]

The bolts shall be made of high-quality carbon steel (galvanized or otherwise rust-proofed) or stainless steel.

The treatment of the ceiling varies from building to building. Please consult with the decoration engineers of the building for specific measures.

The fixing of lifting bolts depends on the specific situation and must be firm and reliable.

## Installation of lifting bolts

See the table below for the installation locations of lifting bolts.

### In the case of concrete slab

Use embedded bolts or stay bolts.



### In the case of steel frame

Set up and use supporting angle steel directly

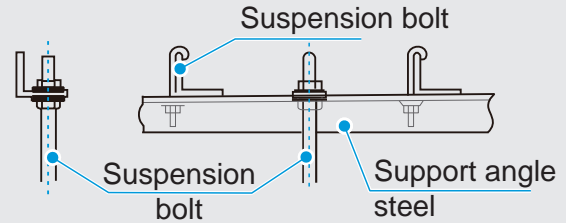

## Installation of Indoor Units

### [Caution]

The indoor unit shall not be installed close to the ceiling, and it shall be kept level or within 1° inclination towards the drainage side. (For the models without drainage pumps, an inclination of 1/100 towards the drainage side is required, and any inclination towards the non-drainage side is not allowed.) Otherwise, it will cause poor drainage and water leakage.

After the indoor unit is lifted, measures shall be taken to prevent dust and debris. For example, the accompanying plastic packing bags may be used for protection.

- ① Adjust the position of the nut, determine the gap between the washer (lower side) and the ceiling according to the actual construction conditions, control the distance  $h$  between the lifting lug and the lifting bolt within the range of 40~80 mm, so as to facilitate the pipe connection and the removal of electrical box cover.

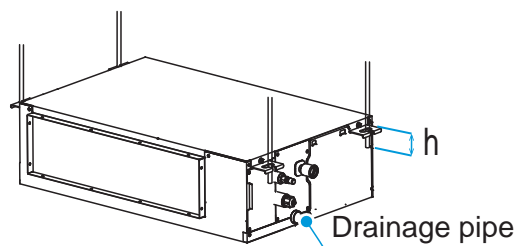

- ② Put the lifting bolt into the oblong hole of the lifting lug, and be sure to fix the upper and lower parts of the lug with washers and nuts.

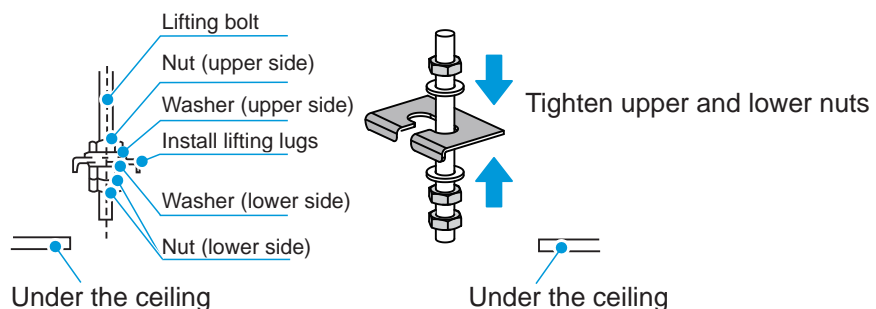

- ③ Observe the water level with a transparent soft water pipe (law of communicating vessels), and confirm the levelness in the width direction of the unit to keep it level.

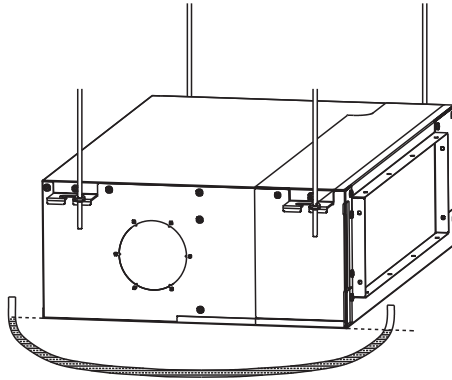

- ④ Observe the water level with a transparent soft water pipe (law of communicating vessels), and confirm the inclination angle in the length direction of the unit. The inclination angle shall be 1/100 downward to the drainage side, and any inclination downward to the non-drainage side is not allowed.

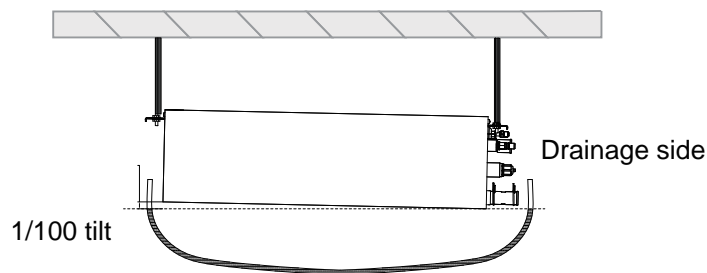

- ⑤ For models with fresh air function, please remove the knockout hole at the fresh air unit on the side of the machine with diagonal pliers or other tools before installing the indoor unit. Install the fresh air flange at the fresh air unit and fix it with flange connecting screws.

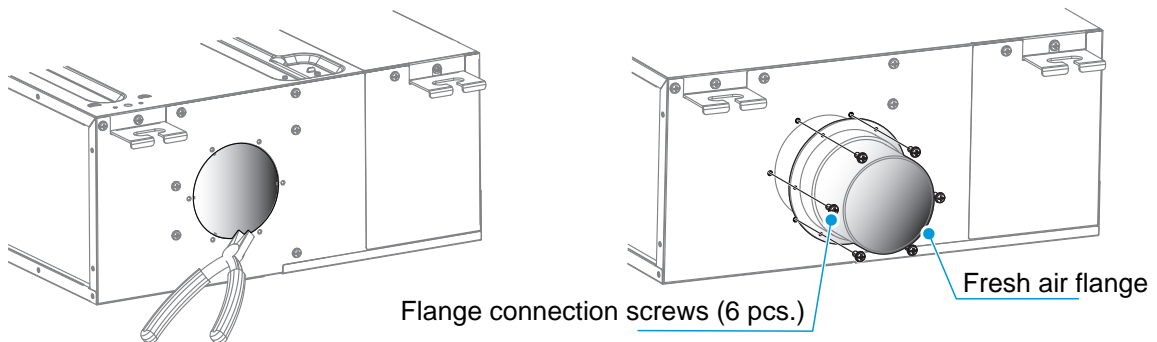

### [Warning]

When connecting the fresh air equipment, please note that the fresh air duct needs to be insulated properly. It is recommended to cover it with foam insulation materials with a thickness of more than 10 mm.

The temperature difference between the fresh air temperature provided by the fresh air equipment to the indoor unit and the indoor temperature should not exceed 5°C. Otherwise there is a risk of condensation in the return air area of the air conditioner. Please use fresh air equipment with temperature regulation function. Alternatively, cover the enclosure of the side wall of fresh air outlet of the air conditioner with foam insulation materials with a thickness of more than 10 mm, and adjust the area and thickness appropriately according to the actual use conditions.

## Air Inlet Panel of Return Air Box

### [Caution]



When making the air inlet panel of the return air box, pay attention to the spacing between the air inlet grilles. The angle shall be kept parallel to the air inlet direction as far as possible.

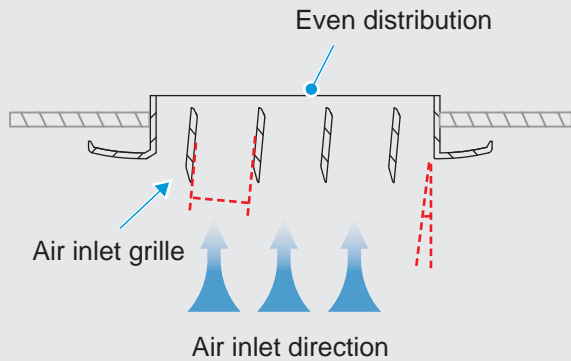

The spacing between the return air grilles shall neither be too large nor too small, and the angle shall not deviate too much from the air inlet direction.

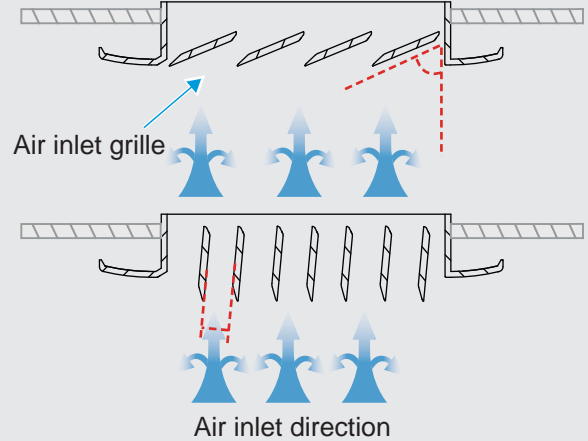

If the air outlet panel is far away from the unit and needs to be connected to the air outlet flange of the unit through a metal air duct, sponge shall be pasted on the contact surface of sheet metal for sealing and thermal insulation.

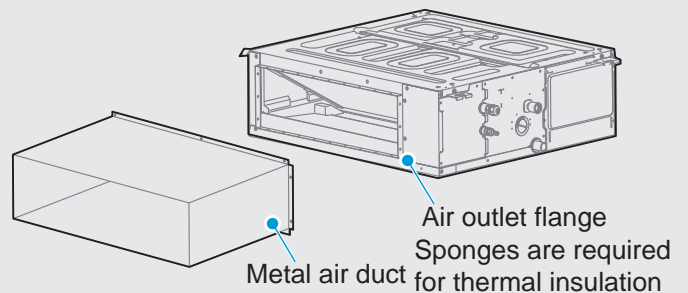

## 6 Installation of Refrigerant Connecting Pipe

The length and height difference of connecting pipes are different for the connection of different outdoor units. For details, please refer to the installation and operation manual of the outdoor unit.

### [Caution]

During the installation of connecting pipes, air, dust and other debris shall be prevented from entering the pipeline system, and the inside of pipes must be kept dry.

The connecting pipes can be installed only after both the indoor and outdoor units have been fixed.

During the installation of connecting pipes, the actual installation length of the liquid pipe shall be recorded on site to facilitate the filling of refrigerant.

Copper pipes must be wrapped with insulation materials.

In case of refrigerant gas leakage during operation, please ventilate immediately.

## Pipe arrangement

- ① Bend the pipes or drill holes in the wall as needed. The bending deformation rate of the pipe shall not exceed 15%. Protective casing shall be provided at the place where the pipe passes through the wall or floor slab, and no weld shall be covered by the casing. The hole where the pipe passes through the outer wall must be sealed and tightly wrapped with binding tape to prevent impurities from entering the pipe. The pipes must be insulated with insulation pipes of appropriate size.

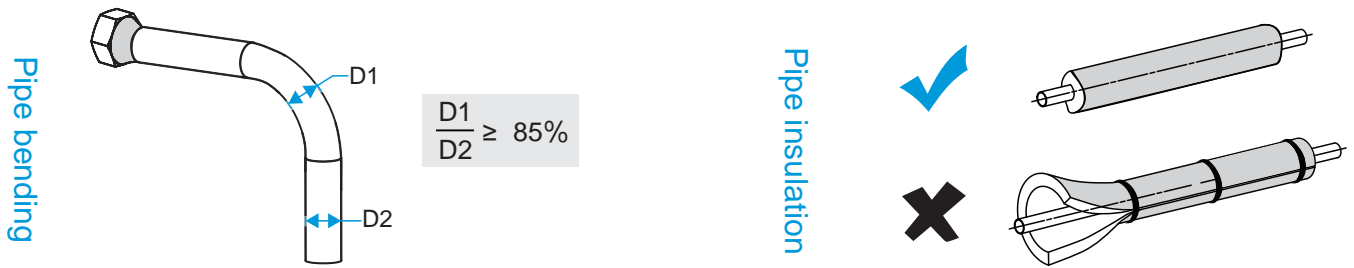

Note: D1 is the minimum diameter and D2 is the nominal diameter

- ② The wrapped connecting pipe shall be plugged through the wall hole sleeve from the outdoor side and enter the indoor side. The pipes must be routed carefully to prevent damage.

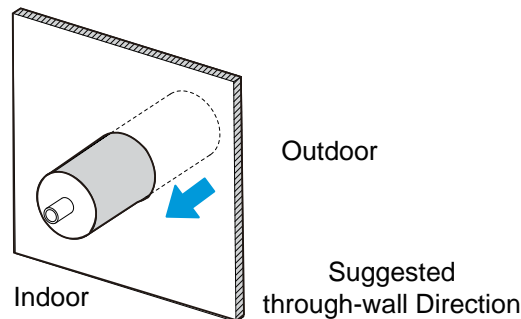

## Pipe connection steps

Measure the required length of the connecting pipe, and make the connecting pipe according to the following method (see the section "pipe connection" for details).

- Connect the indoor unit first, and then connect the outdoor unit.
- ① Before tightening the flared nut, apply refrigerant oil (must be compatible with the refrigerant of the unit) on the outer surface of the pipe flare, and then tighten the nut by hand for 3~4 turns. When connecting or removing pipes, both wrenches must be operated at the same time.

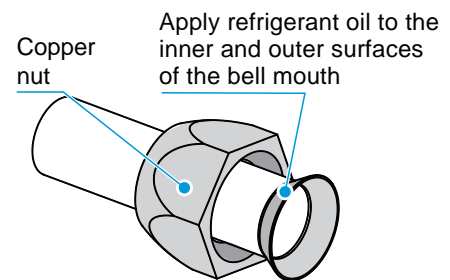

### [Caution]

 The piping shall be bent and arranged carefully so as not to damage the piping and its insulation layer.



Do not let the weight of the connecting pipe be borne by the joint of the indoor unit, because if the pipe at the joint of the indoor unit is too heavy, the connecting pipe will be flattened and deformed, which will affect the cooling (heating) effect or compress the insulation material, causing air leakage and condensation.

- ② The stop valve of the outdoor unit is fully closed when it is delivered out of the factory. For each connection, unscrew the nut from the stop valve and connect the flared pipe within 5 minutes. If the nut at the stop valve is removed for a long time, dust and other debris may enter the piping system, which may cause faults after long-time operation.

- ③ After the refrigerant pipes are connected to the indoor and outdoor units, remove the air according to the instructions in the column "air removal". After the air is removed, tighten the maintenance nut.

## Pipe connection

Bend the pipe with your thumbs

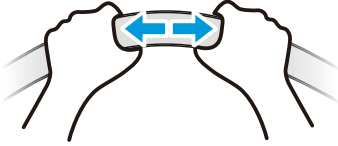

### Processing method

- ① Manual bending: applicable to small copper pipes ( $\phi 6.35$ - $12.7$  mm).
- ② Mechanical bending: applicable to a wide range ( $\phi 6.35$ ~ $28$  mm), using spring type, hand-operated or electric pipe bender.

### [Caution]

The bending angle shall not exceed  $90^\circ$ . Otherwise, wrinkles will be generated in the tube, which is easy to cause pipe rupture.

The bending radius shall not be less than  $3.5D$  (pipe diameter) and shall be as large as possible to prevent the pipe from being flattened or crushed.

In the case of mechanical bending, the pipe bender inserted into the copper pipe must be clean.

## 1 Brazing of pipe

If the pipe is welded by brazing, nitrogen shall be filled into the pipe. The inner pipe shall be heated fully and evenly first, and then the outer pipe shall be heated evenly. The welding material shall be fully fed into the joint part of the pipe.

### [Caution]

If the pipe is required to be filled with nitrogen during welding, its pressure must be controlled at  $0.02$  MPa with a relief valve.

Flux shall not be used for the welding of refrigerant connecting pipes. Please use phosphor copper solder that does not require flux (GB/T 6418-93BCu93P).

Do not use any antioxidants when welding pipes, because the pipes may be blocked by residual antioxidants, and components such as electronic expansion valve may be blocked after the unit is operated, thereby causing faults.

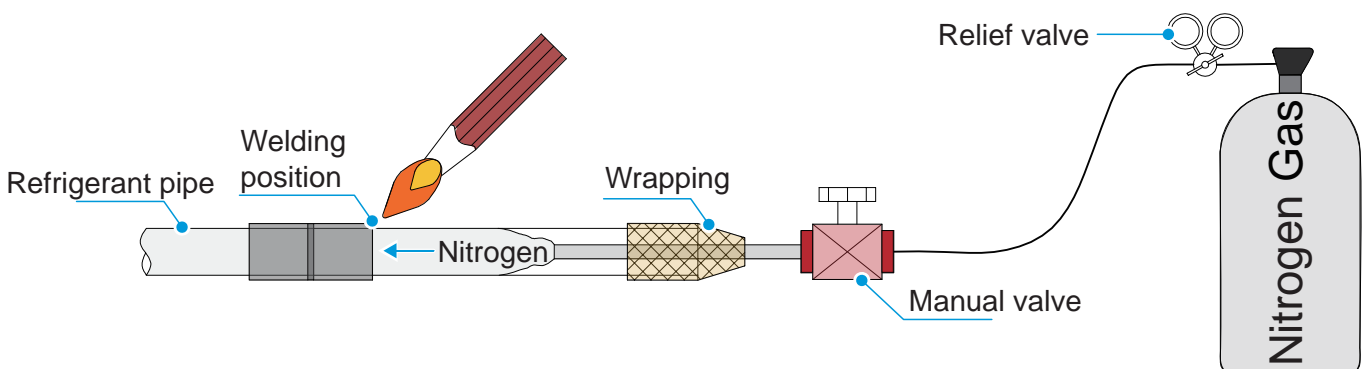

## 2 Flaring

Cut off the pipe by rotating the pipe cutter repeatedly.

Flare the pipe with the connecting nut, and connect the air ducts and liquid pipes of the indoor unit by flaring method.

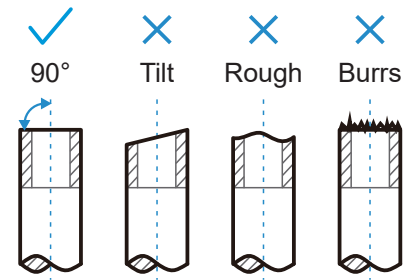
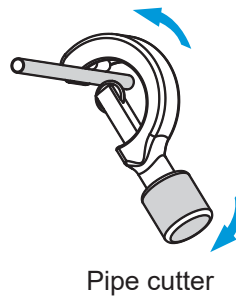
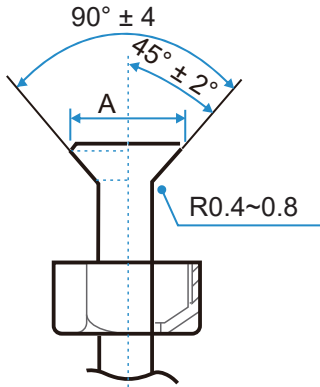

Outer diameter (mm)	A (mm)	
	Maximum	Minimum
φ6.35	8.7	8.3
φ9.52	12.4	12.0
φ12.7	15.8	15.4
φ15.9	19.1	18.6
φ19.1	23.3	22.9

## 3 Nut fastening

- Align the connecting piping, firstly tighten most of the thread of the connecting nut by hand, and then use a wrench to tighten the last 1-2 turns of the thread as shown in the figure.
- The welding is done on site, and the bell mouth cannot be used indoors. (For IEC/EN 60335-2-40 except IEC 60335-2-40: 2018)
- The protective nut is a one-time part, it can not be reused. In case it is removed, it should be replaced with a new one. (For IEC 60335-2-40: 2018 only)

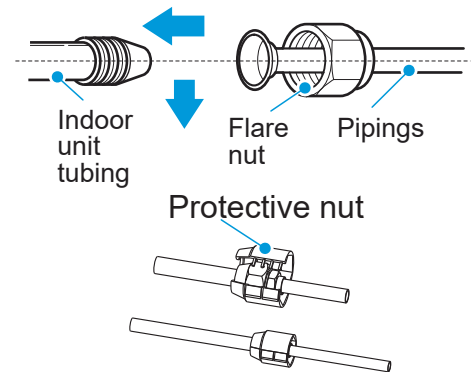
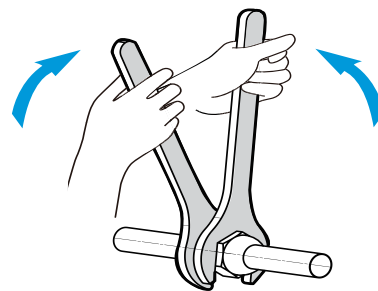
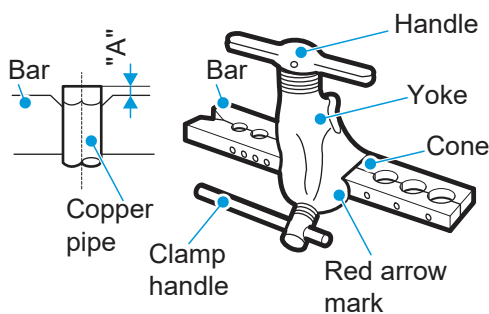

### [ Caution ]

Excessive torque can break nut on installation conditions.  
When flared joints are reused indoors, the flare part should be re-fabricated.

Pipe size (mm)	Tightening torque [ N.m (kgf.cm) ]
Φ6.35	14.2–17.2 (144–176)
Φ9.52	32.7–39.9 (333–407)
Φ12.7	49.5–60.3 (504–616)
Φ15.9	61.8–75.4 (630–770)
Φ19.1	97.2–118.6 (990–1210)

## Fixing of refrigerant pipe

Angle steel supports or round steel hangers should be used for fixing. If the liquid pipe and the air duct are suspended together, the fixing shall be based on the size of the liquid pipe.

Outer diameter of pipe (mm)	≤20	20~40	≥40
Horizontal pipe spacing (m)	1.0	1.5	2.0
Riser spacing (m)	1.5	2.0	2.5

## Air removal

Connect the refrigerant pipe to the gas and liquid sides of the outdoor unit, and use vacuum pumps for vacuumizing from both sides at the same time.

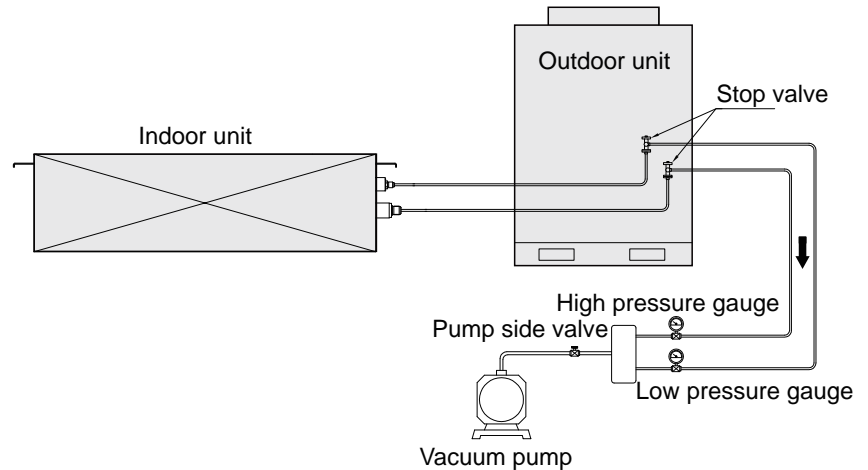

It is not allowed to use the refrigerant sealed in the outdoor unit for vacuumizing. The reduction of refrigerant in the outdoor unit will lead to performance degradation of the air conditioner.

## Leakage inspection

During leakage inspection, soap bubbles shall be used to check for leaks at the valve joints of the pipe connection.

## Insulation treatment

During cooling, the temperature of the pipe on the liquid side and air side is low. In order to prevent condensation, please take adequate insulation measures.



- Heat-resistant insulation materials above 120 °C must be used for gas-side pipe.
- The pipe connection part of the indoor unit shall be insulated with auxiliary insulation materials without gap.
- Additional protective treatment, such as adding metal pipe box and wrapping aluminum-platinum material, shall be carried out for the outdoor pipe part. Insulation materials exposed to the open air for a long time will age and lose their insulation performance.

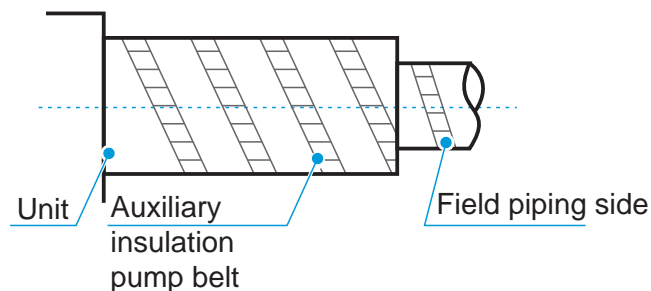

# 7 Installation of Drainage Pipe

## [Caution]

Before the installation of condensate water pipes, their direction and elevation shall be determined to avoid crossing with other pipes and ensure smooth and straight slope.

An exhaust port shall be provided at the highest point of the drainage pipe to ensure smooth discharge of condensed water. The exhaust port must face downwards to prevent dirt from entering the pipe.

It is strictly prohibited to connect drainage pipes to sewage pipes, fecal pipes and other pipes that are likely to produce corrosion or unpleasant odor, so as to avoid corrosion of indoor units (especially heat exchangers) and unpleasant odor in rooms, which will seriously affect heat exchange effects and user experience. The installation party will be held responsible for the consequences caused by the installation not as required.

After the pipe connection is completed, a water test and a full water test shall be carried out to check whether the drainage is smooth on the one hand and whether the piping system leaks water on the other hand.

The drainage pipe of the air conditioner must be installed separately from other sewage pipes, rainwater pipes and drainage pipes in the building.

The piping system shall be free of adverse slope and convex and concave pipes to prevent poor drainage caused by air resistance.

All drainage pipes shall be evenly wrapped with insulation pipes to prevent the generation of condensed water.

Please follow the following method to connect the drainage pipes. Improper installation of pipes will result in water leakage and damage to furniture and property. All joints of the drainage system must be sealed to prevent water leakage.

## Installation of drainage pipe of indoor unit

①

Models without a water pump: connect the water pan outlet to the PVC water pipe with the accessory drain hose, fasten the connections at both ends of the drain hose with cable ties, push the insulation pipe to be closely attached to the main body of the unit, and then fasten it tightly at the end with cable ties.

Models with a water pump: connect the PVC water pipe to the water pump outlet directly, fasten them tightly with cable ties, push the insulation pipe to be closely attached to the main body of the unit, and then fasten it tightly at the end with cable ties.

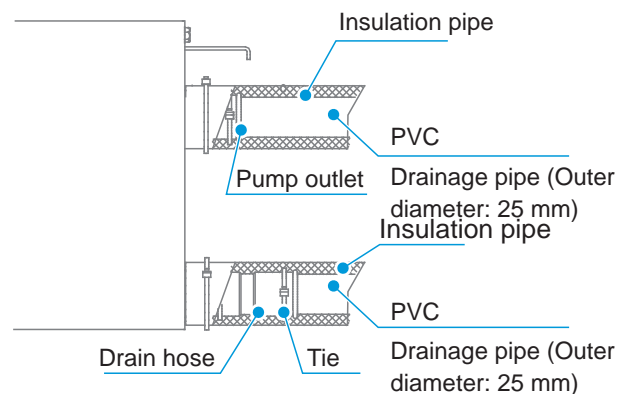
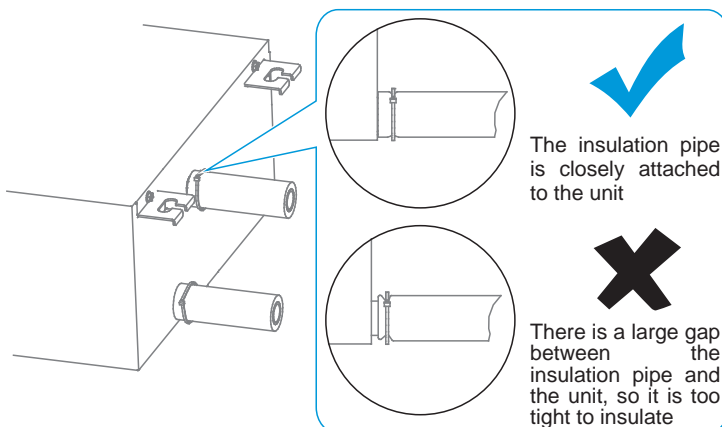
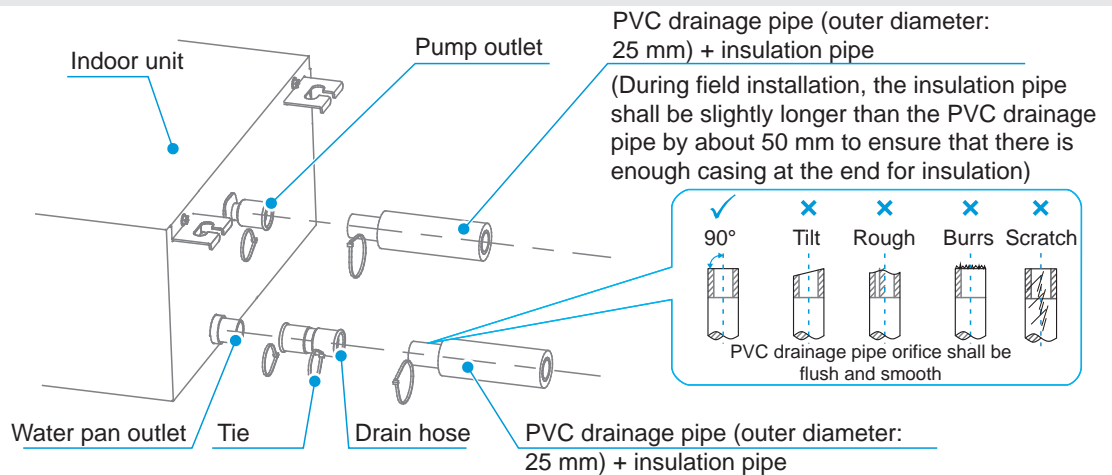

- ② The connections at both ends of the drain hose and the connection of the water pump outlet shall be fastened with cable ties only, and PVC/rubber adhesive shall be used as an auxiliary. Please note the instructions for use of adhesive. Do not cause continuous corrosion to EPDM. Rigid PVC adhesive shall be used for the connections of other water pipes. In addition, please confirm that there is no leakage.

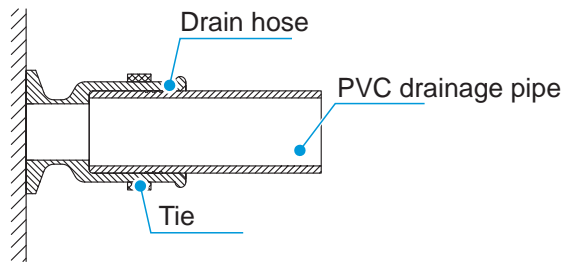

- ③ The pumping connecting pipe and drainage pipe (especially the indoor part) of the main body shall be evenly wrapped with insulation pipes and fastened tightly with cable ties to prevent air from entering the pipe and to prevent the generation of condensed water.

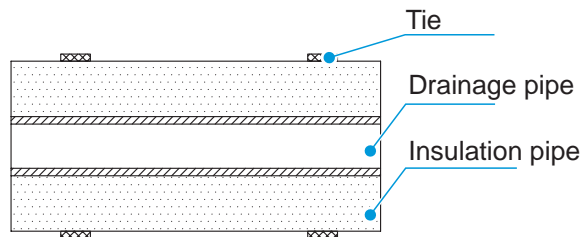

- ④ In order to prevent water from flowing back into the air conditioner when it is stopped, the drainage pipe shall be inclined downward to the outdoor side (drainage side), with a downward inclination of more than 1/100. In addition, the left and right directions of the drainage pipe shall be consistent with those of the unit drainage outlet, and the drainage pipe shall not expand and trap water. Otherwise, it will cause abnormal noise.

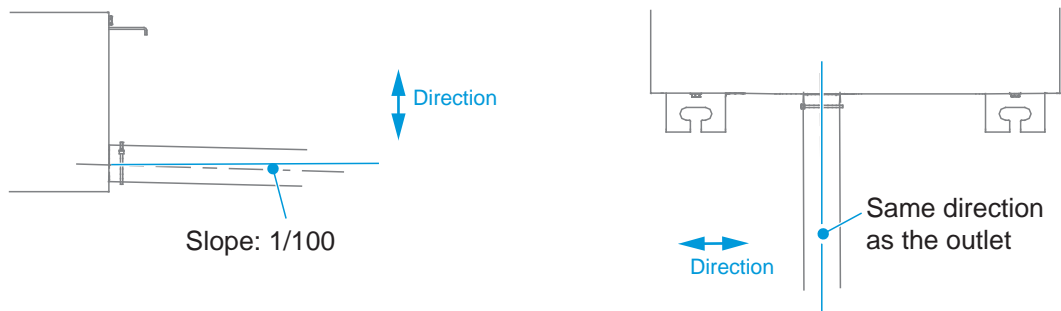

- ⑤ When connecting the drainage pipe, please do not pull the drainage pipe hard to avoid the drainage pipe joint from coming loose. The drainage pipe shall be pulled out within 20m horizontally, with a supporting point set every 0.8~1.0m to avoid deflection of the drainage pipe, or air resistance will be caused. Drainage risers shall be provided with a supporting point every 1.5~2.0m.

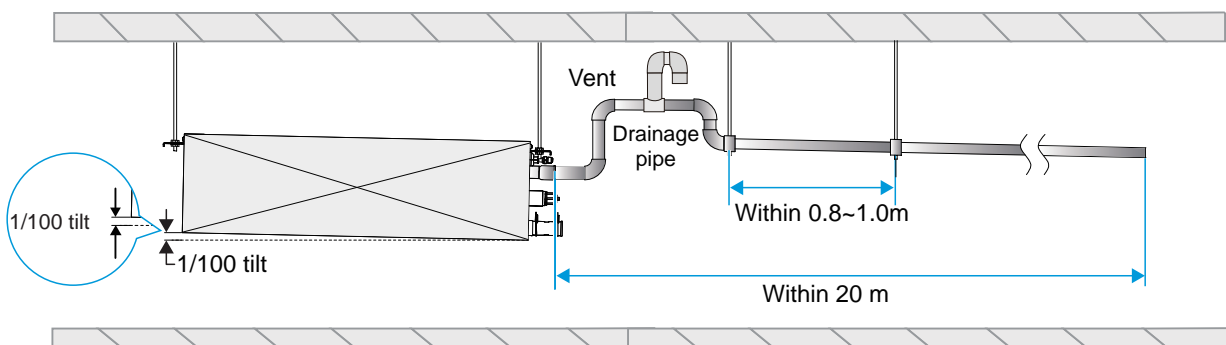

- ⑥ The end of the drain pipe shall be more than 50mm from the ground or the bottom of the drainage channel. Do not put the drainage pipe in water. When the condensate is discharged directly to the sewer, the drainage pipe must be bent upwards to form a U-shaped water seal to prevent stench from entering the room through the drainage pipe.

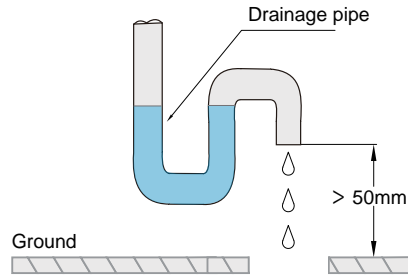

- Connection mode of drainage pipes using drainage pumps:

(unit: mm)

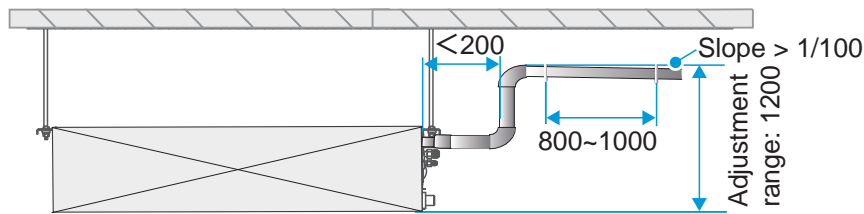

Connection mode of drainage pipe of drainage pump for single machine

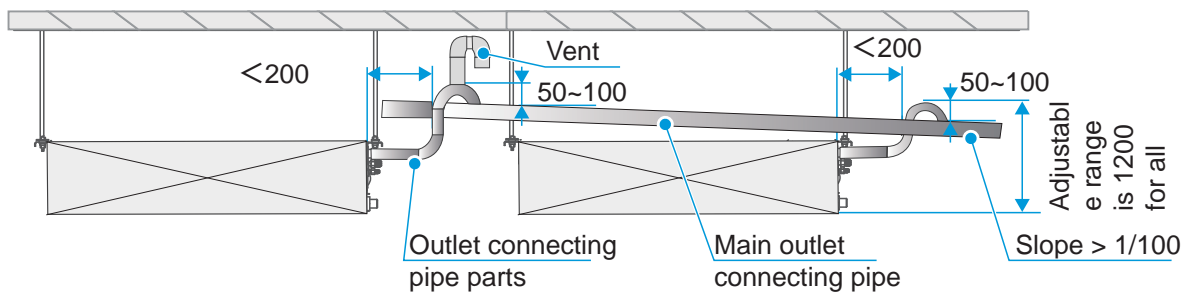

Drainage pipes of drainage pumps for multiple machines are connected to the sewer via the main drainage pipe

- Be sure to arrange horizontal drainage pipes properly to prevent them from flowing directly towards each other. Otherwise backward flow and poor drainage will be caused.

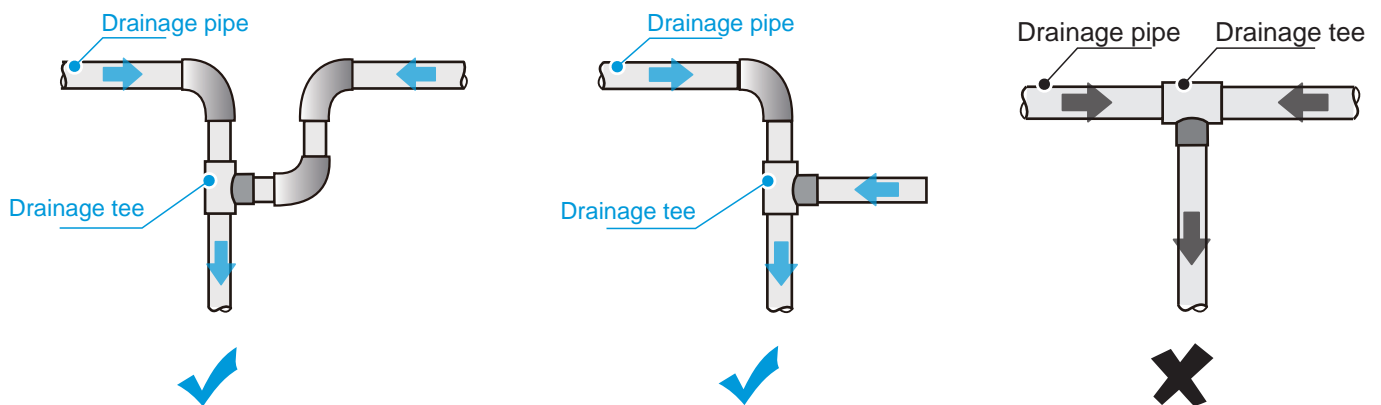

- Connection mode of drainage pipes without drainage pumps:

(unit: mm)

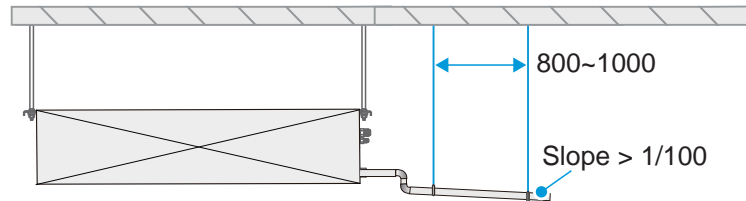

Connection mode of drainage pipes for a single machine

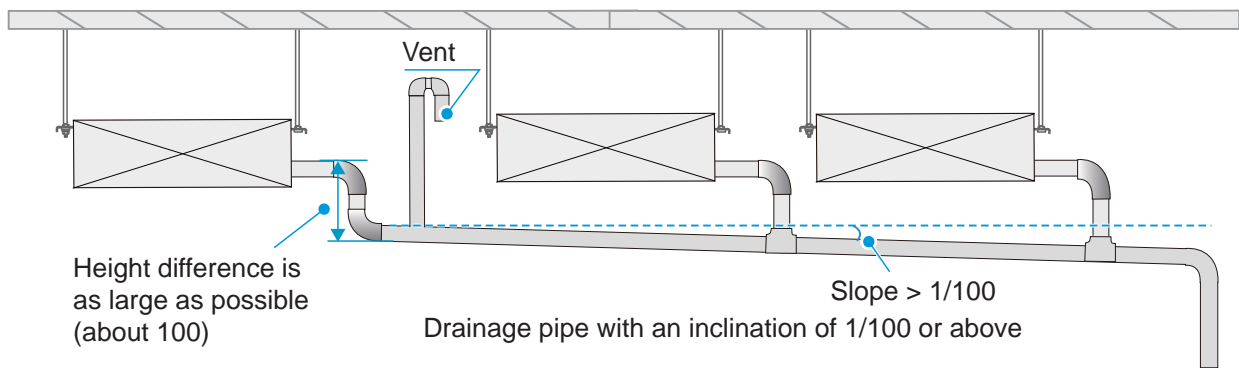

Drainage pipe with an inclination of 1/100 or above

Drainage pipes of multiple machines are connected to sewers via the main drainage pipe

## Drainage test

- ① Before the test, ensure that the drainage pipeline is unblocked, and check whether all joints are sealed properly.
- ② New rooms shall be subject to drainage tests before laying ceiling.
  - Inject water into the water pan using the water filling pipe. Refer to the table below for the water injection rate.
  - Switch on the power and operate the air conditioner for refrigeration. Check whether the water is drained properly at the drainage port (the water can be drained after a delay of about 1 minute, depending on the length of the drainage pipe), and check whether there is water leakage at each joint.
  - If the water is drained with the help of the drainage pump for the indoor unit, the water testing cover (the black round plastic part) on the machine body needs to be unscrewed during the drainage test to check whether the drainage pump is turned on. If the drain pump is not turned on, check whether there is a problem with the drainage pump. In addition, it should be noted that the drainage pump is only turned on in the cooling mode, and will always be off in the heating mode. After the drainage test, the water testing cover needs to be installed back to its original position. The water testing cover and water filling pipe are shown in the figure below.

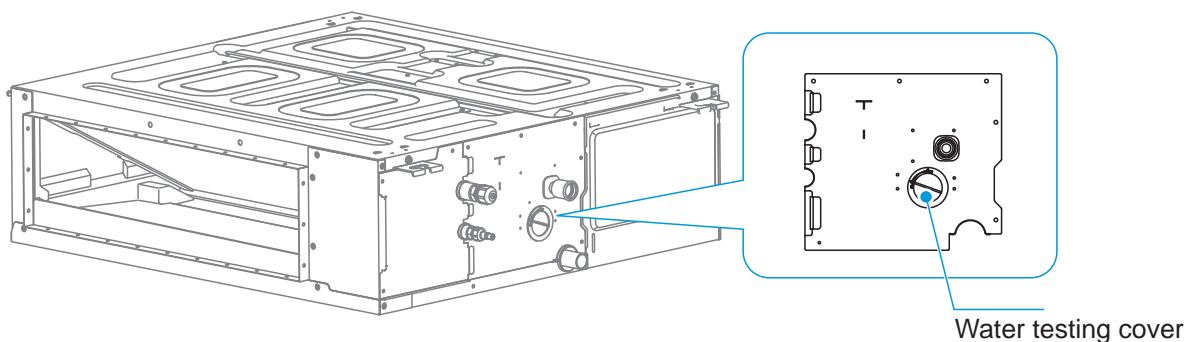

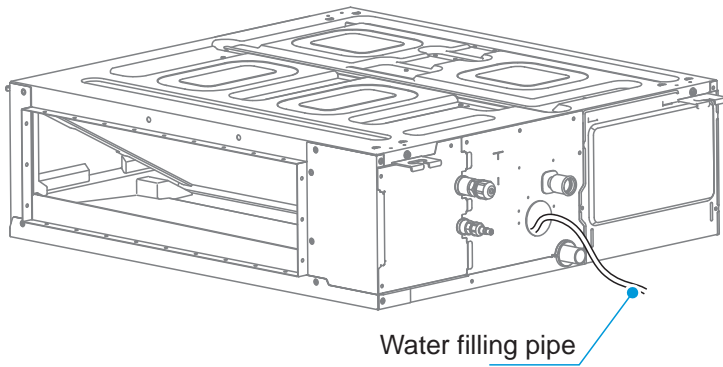

Water injection rate: (unit: ml)

Indoor unit model	Water injection rate
15~45	1500
56~71	1800
80~90	2200
112~160	3000

## 8 Installation of Air Duct

- ✔ Please connect the locally purchased air ducts and flexible air ducts (note that the eco-friendly and odorless materials should be selected to avoid air pollution and unpleasant odor when the air conditioner is operating).
- ✔ Install the flange on the return air side, and seal the flange on the return air side and the air duct connection with aluminum tape to avoid air leakage.
- ✔ Seal the air supply side flange and the air duct connection with aluminum tape etc. to avoid air leakage.
- ✔ Air supply side ducts shall be insulated with thermal insulation material to prevent condensation of the duct.
- ✔ When installing air ducts and components, fix and adjust the supports and hangers when necessary to make their positions correct and stress uniform.
- ✔ Before installation of air ducts and components, the ducts shall be clean and free of sundries.
- ✔ After the installation of air ducts and components, the air ducts shall be tested for tightness, and the air leakage rate shall comply with the provisions of national standards.

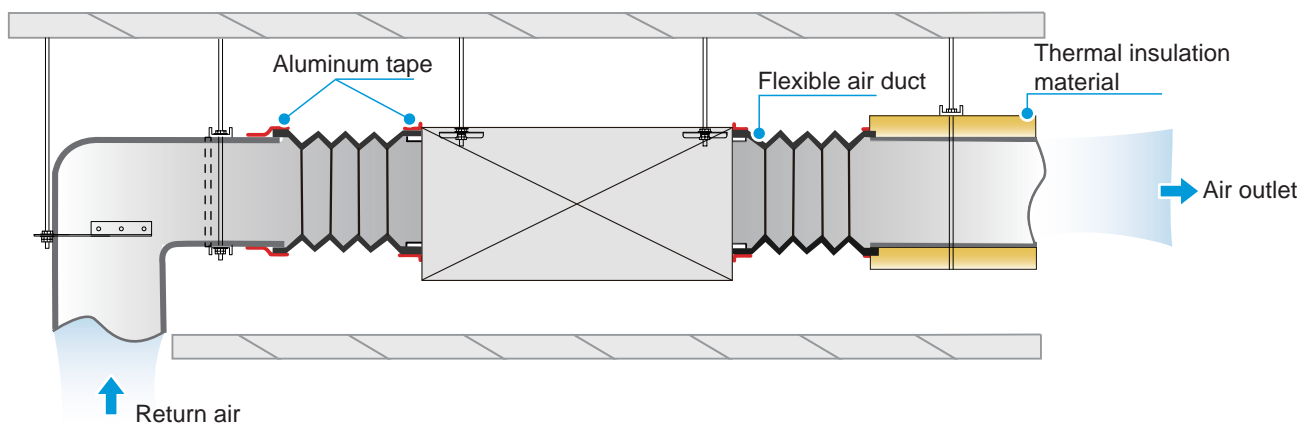

## [Caution]

It is forbidden to dislocate the connection between the air duct of the air conditioner outlet and the return air outlet and the ceiling opening to prevent the short circuit of the return air. (please refer to the figure below)

Canvas or flexible air ducts shall be used to connect indoor units and air ducts, at an effective distance (width) of 150~300mm.

Wires, cables and other toxic, inflammable and explosive gases or liquid pipes shall not be laid in the air ducts.

The air duct regulator shall be installed in a position, easy to operate, in a flexible and reliable manner.

The vents are installed and connected with the air duct tightly and firmly.

The frame are closely attached to the building decoration, and the outer surface shall be flat and flexibly adjusted, rather than being twisted or used for deviation adjustment.

When the vent is horizontally installed, the deviation of levelness is not more than 3/1000; When the vent is vertically installed, the deviation of verticality is not more than 2/1000.

The same vents in the same room shall be installed at the same height above the ground and in alignment.

All metal accessories (including supports, hangers and brackets) of the pipeline system works shall be subject to anti-corrosion treatment.

Failure to connect between vent and air duct

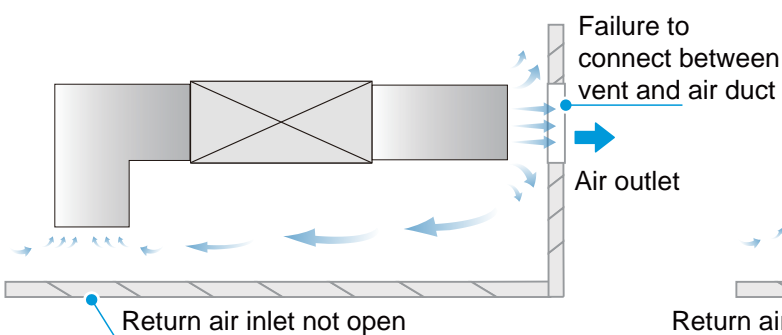

Mismatching of size and position of vent

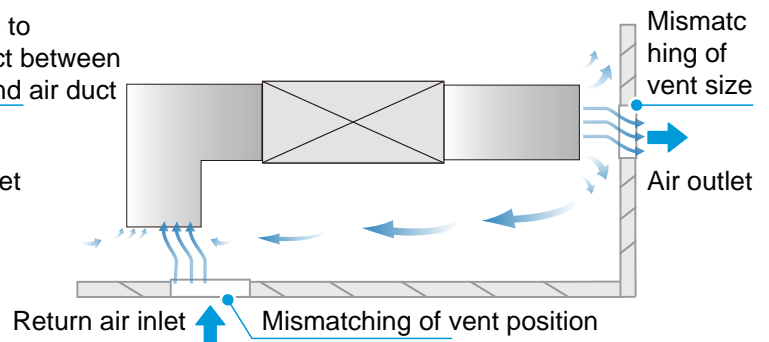

Correct size and position of the air intake

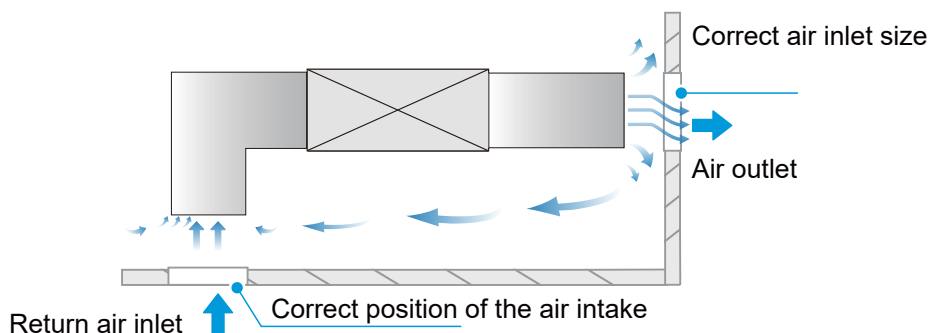

# 9 Electrical Wiring Operation

## [Danger]

The power supply must be switched off before any electrical operation. Living working is strictly forbidden, otherwise serious personal injury may be caused.

The air conditioning unit shall be reliably grounded in accordance with GB-50169 Code for Construction and Acceptance of Grounding Connection Electric Equipment Installation Engineering. Improper grounding might result in electric leakage, thereby causing serious personal injury.

## [Warning]

Professional technicians are required to perform the installation or inspection and maintenance; All parts and materials must conform to the relevant regulations of the local country/ region.

A dedicated power supply must be used for the air conditioning unit, with the power supply voltage conforming to the nominal operating voltage range of the air conditioning unit.

The power supply of the air conditioning unit must be provided with a power disconnecter that conforms to the requirements of relevant national technical standards for electrical equipment. The power disconnecter must be provided with short-circuit protection, overload protection and leakage protection functions. The clearance between open contacts of the power disconnecter shall be at least 3mm.

Power cords shall be copper-core cables, with the wire diameter meeting the current-carrying requirements. For details, please refer to "Selection of Power Cord Diameter and Leakage Protector". The power cords with a smaller wire diameter may cause the power cord to heat up, thereby resulting in a fire.

Power cords and ground wires shall be reliably fixed to avoid stress on the terminal. Do not pull the power cord hard; Otherwise, the wiring may come loose or the terminal may be damaged.

Power cords and other strong current wires cannot be connected to weak current wires such as communication cables. Otherwise the product may be seriously damaged. It is strictly forbidden to bond and connect power cords.

Bonding and connecting the power cord may cause it to heat up, thereby resulting in a fire.

## [Caution]

Communication cables shall not be bonded and connected as far as possible. If the line is not long enough, reliable connection can be ensured by wire pressing or soldering, without the copper wire at the connection exposed. Otherwise communication faults will be caused.

In stead of being staggered, the power cords and communication cables shall be routed separately at a spacing of more than 5cm. Otherwise communication faults may be caused.

Keep the vicinity of the air conditioning unit as clean as possible to avoid small animals nesting and biting the lines. The line contact or a bite by small animals may result in a short circuit or electric leakage, thereby cause danger.

Do not connect the ground wire to gas pipes, tap water pipes, lightning rod ground wires or telephone ground wires.

Gas pipes: There will be a risk of explosion and fire in case of gas leak.

Water pipes: There will be no grounding effect in case rigid plastic pipes are used.

Lightning rod ground wires or telephone ground wires: There will be a risk of abnormal rise in ground potential during lightning stroke.

After all wiring construction is completed, check carefully before switching on the power supply.

## Electrical characteristics

Machine capability (KW)	Power supply				Fan motor in air conditioner	
	Frequency (Hz)	Voltage (V)	MCA (A)	MFA (A)	Power (W)	FLA (A)
1.5	50 or 50/60	220-240	0.63	15	50	0.50
2.2			0.63		50	0.50
2.8			0.63		50	0.50
3.6			0.80		50	0.64
4.5			1.19		50	0.95
5.6			1.19		60	0.95
7.1			1.50		60	1.20
8.0			1.50		240	1.20
9.0			1.63		240	1.30
11.2			2.29		240	1.83
12.5 / 14.0			2.31		240	1.85
16.0			2.76		240	2.21

## Notes:

MCA: Min. Circuit Amps. (A) that is used to select the minimum wire diameter for safe and long-term operation.

Model with auxiliary electric heating function  $MCA=FLA*1.25+AUX*1.25$

MFA: Max. Fuse Amps. (A) that is used to select the specification of circuit breakers.

FLA: Full Load Amps. (A) , the full load (steady operation at maximum speed) current of motor.

AUX.: Electric auxiliary thermal current (A).

## Wire diameter selection (minimum)

Rated current (A)	Nominal cross-sectional area (mm <sup>2</sup> )	
	Flexible wire	Hard wire
≤3	0.5 and 0.75	1 to 2.5
>3 and ≤6	0.75 and 1	1 to 2.5
>6 and ≤10	1 and 1.5	1 to 2.5
>10 and ≤16	1.5 and 2.5	1.5 to 4
>16 and ≤25	2.5 and 4	2.5 to 6
>25 and ≤32	4 and 6	4 to 10
>32 and ≤50	6 and 10	6 to 16
>50 and ≤63	10 and 16	10 to 25

## User wiring diagram

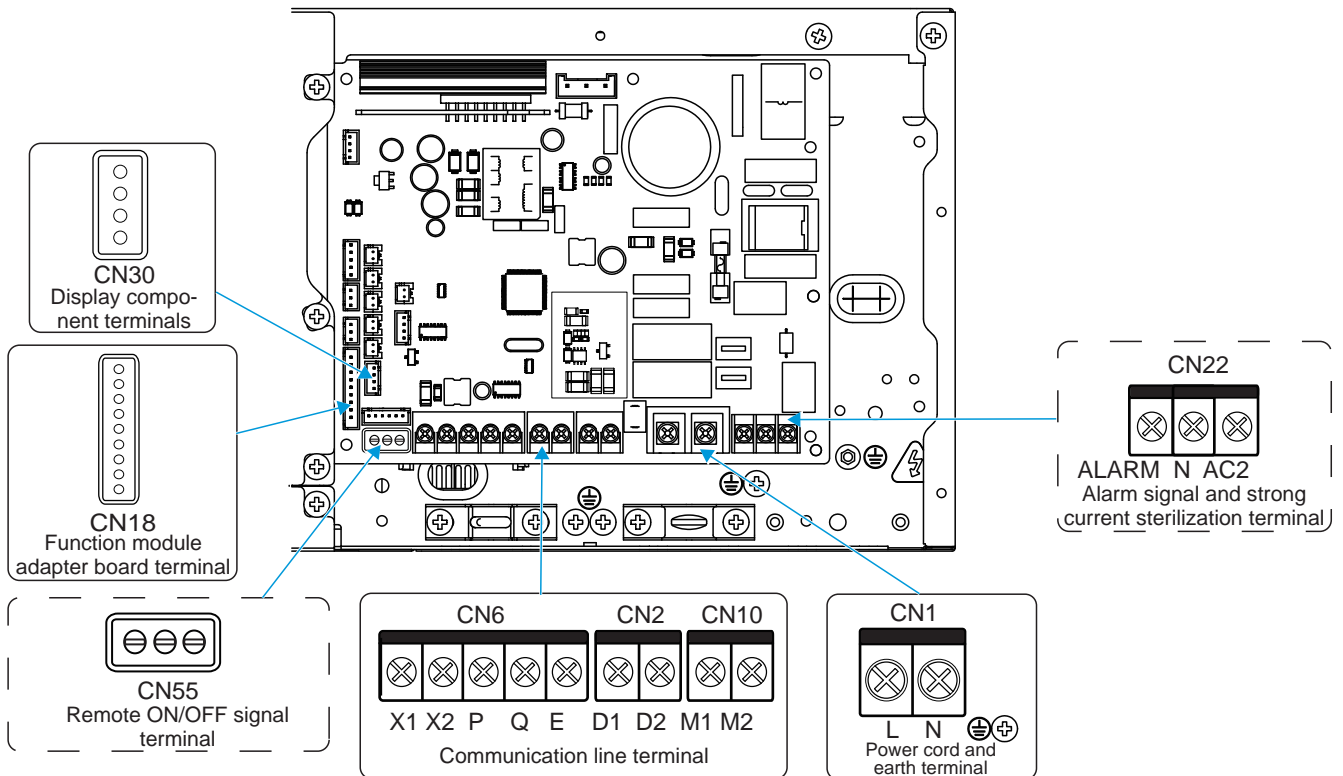

### [Caution]



Both PQ communication and EasyCom communication (M1M2) modes are available for the communication between indoor and outdoor units, but only one mode can be adopted. In the same system, it is forbidden to connect both PQ communication and EasyCom communication; It is forbidden to connect EasyCom communication to PQ or D1D2 communication.

All weak point connection points meet SELV, such as X1, X2, P, Q, E, M1, M2, CN18, CN55 etc.

## Wiring

- 1 Open the electric control box cover of the indoor unit.
  - ① Remove the screws shown in the figure;
  - ② Pull the bottom of the electric control box cover outward horizontally for a certain distance;
  - ③ Take out the electric control box cover downward.

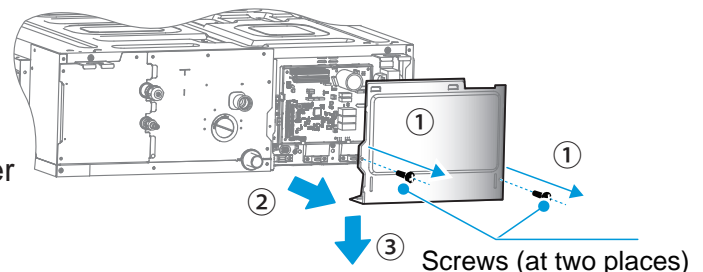

- 2** Connect strong current wires (power cord, alarm signal output line, strong current sterilization line) and weak current wires (communication line, display component connection wire, remote ON/OFF connection wire, and free function module connection wire) to the electric control box through the strong and weak current incoming lines.

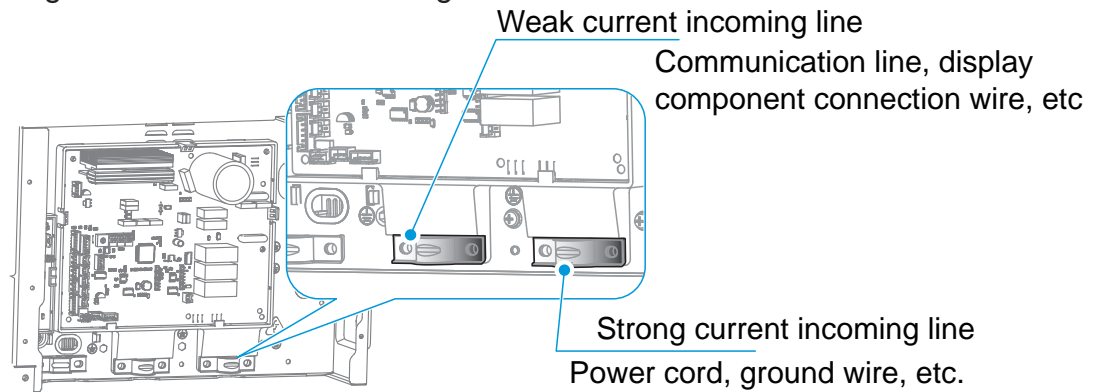

**[Caution]**

Strong and weak current incoming lines must be separated.

Alarm signal output, strong current sterilization, remote on/off, and free function modules are customized or optional.

**3** Power cord connection

① Selection reference for power cord diameter and circuit breaker

Model	15-160 without auxiliary electric heating function	15-160 with auxiliary electric heating function
Minimum cross-sectional area of copper core PVC insulated wire BVV power cord (mm <sup>2</sup> )	3×1.0	3×2.5

Total current of indoor unit	Circuit breaker (A)
5A below	6
6~8A	10
9~14A	16
15~18A	20
19~22A	25
23~29A	32
30~36A	40
37~45A	50
46~57A	63

**[Caution]**

For the selection of power cords and circuit breakers, please refer to the requirements of the above reference table.

The circuit breaker must be provided with short-circuit protection, overload protection and leakage protection functions.

The field wiring must be conducted by professionals / in accordance with the relevant regulations of the local country/region.

The standard value of the screw tightening torque of the power terminal block is 1.0-1.2N.m. Too low torque may cause poor contact and heating, thereby resulting in a fire; Too high torque may damage screws and terminal blocks.

Sheathed copper-core cables must be selected as power cords in accordance with the requirements of GB/T-5013 Rubber Insulated Cables of Rated Voltages up to and Including 450/750V or GB/T-5023 Polyvinyl Chloride Insulated Cables of Rated Voltages up to and Including 450/750V and other relevant standards.

In case of longer power lines, a thicker wire diameter needs to be considered. The voltage drop can be calculated based on the maximum load current of the actual unit, the resistivity of the equipped conductor and the required length to ensure that the voltage drop on the power cord is less than 2% of the power supply voltage. . In case all indoor units are V8 models in the same refrigerant system, either the separate power supply (EasyCom communication with the function of power-down control valve shall be selected for the communication between indoor and outdoor units; For details, please refer to the description below) or uniform power supply can be adopted for indoor units.

In case the indoor unit other than a V8 model is adopted in the same refrigerant system, uniform power supply must be adopted for indoor units. In case of uniform power supply for indoor units, please select the main circuit breaker specification based on the actual current and number of indoor units in the system.

## ② Power cord connection of a single set

Fix the power terminal block of the indoor unit on the mainboard, connect the power cord to the power terminal block "CN1" on the mainboard, connect the live wire and null wire according to the marks "L" and "N" on the mainboard respectively, and connect the ground wire to the sheet metal parts of electric control box directly.

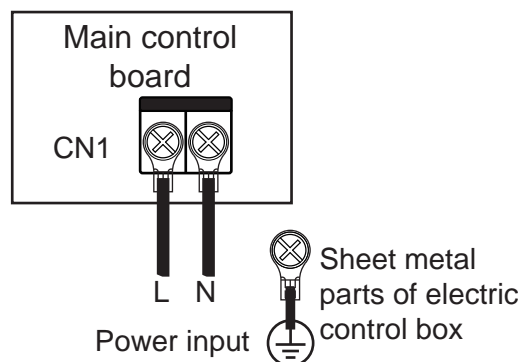

### [Caution]

**A** It is strictly forbidden to bond and connect power cords. Bonding and connecting the power cord may cause it to heat up, thereby resulting in a fire.

**B** Power cords require round wiring terminals with insulation and shall be firmly and reliably crimped before being connected to the power terminal block of indoor unit, as shown in the figure below:

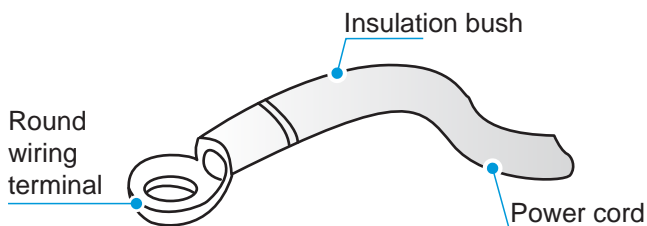

**C** In case it is impossible to crimp the round terminals with insulation due to the limitation of site conditions, connect the power cords of the same wire diameter to both sides of the power terminal of the indoor unit, as shown in the figure below:

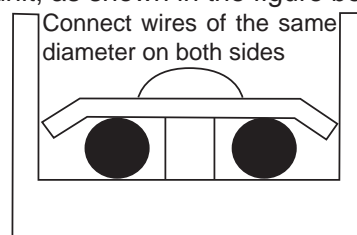

**D** It is forbidden to press the power cords with the same wire diameter on the same side of the terminal, and it is forbidden to use two power cords with different wire diameters for the same terminal. Otherwise, it is likely to cause looseness due to uneven pressure, leading to safety accidents, as shown in the figure below:

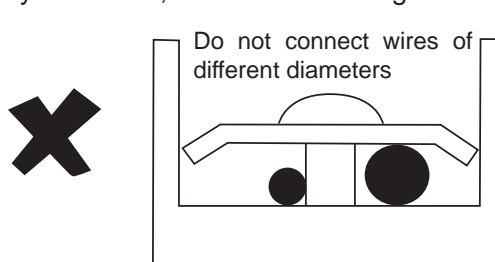
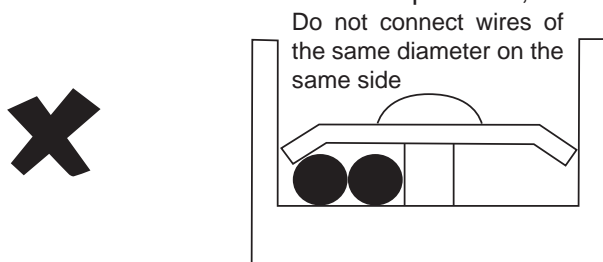

**E** The connected power cord shall be secured with the wire pressing plate to prevent looseness, as shown in the right figure:

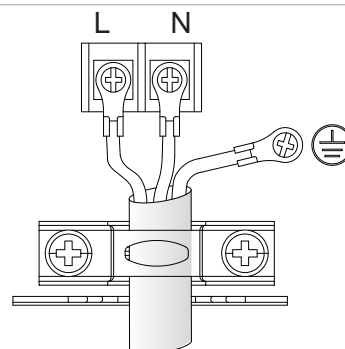

### ③ Power cord connection of the system

A In case of separate power supply for indoor units\* , the wiring diagram is as follows:

EasyCom communication with the function of power-down control valve:

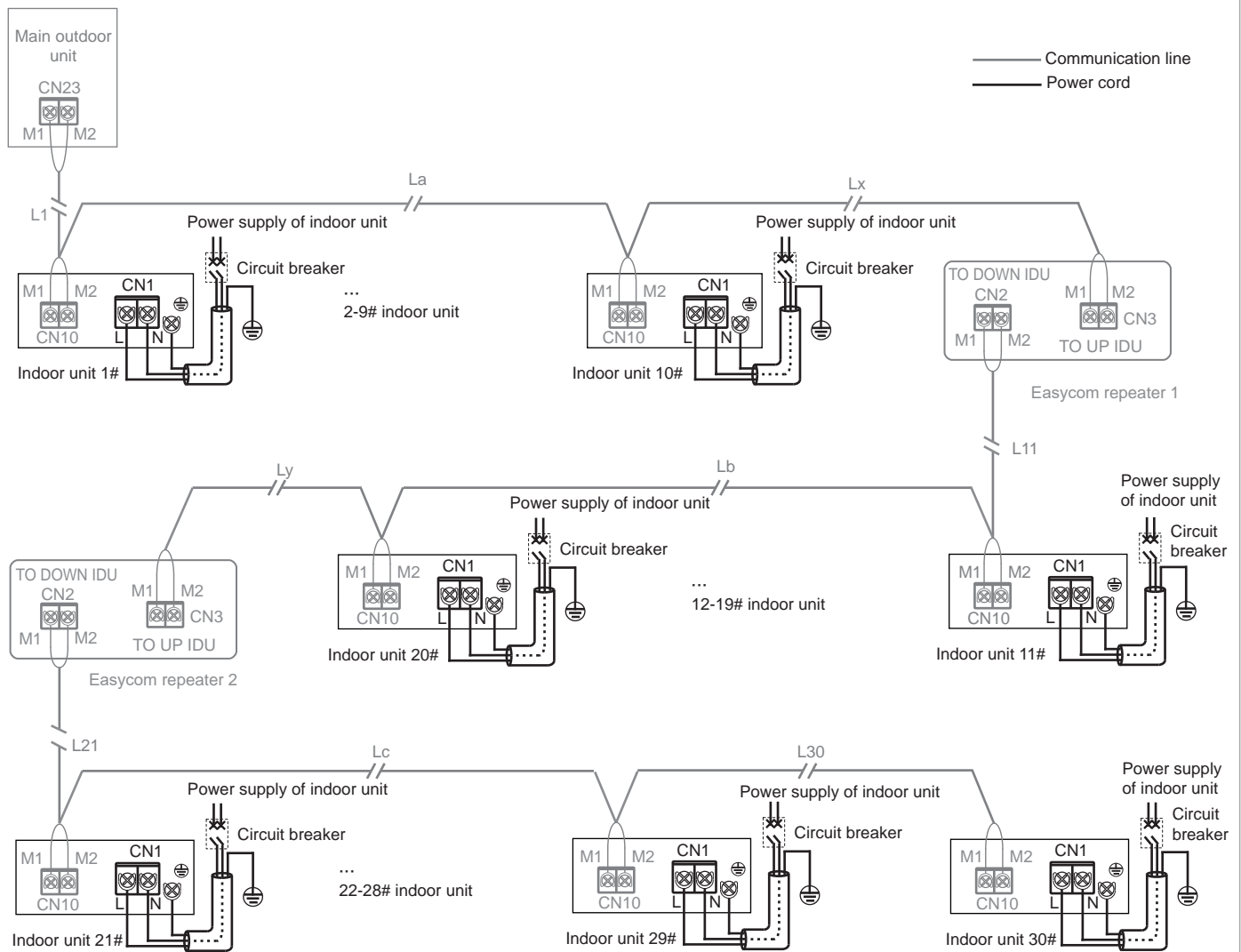

#### [Caution]

In case of separate power supply for indoor units, all the indoor units in the same refrigerant system must be V8 models\* and the EasyCom communication with the function of power-down control valve\* must be adopted for the communication between indoor and outdoor units.

Since the function of power-down control valve is equipped in the above connection mode, the number of indoor units in the same refrigerant system shall be  $\leq 30$ , and only two repeaters\* are required at most.

**B** In case of uniform power supply for indoor units\*, the wiring diagram is as follows:

EasyCom communication without the function of power-down control valve:

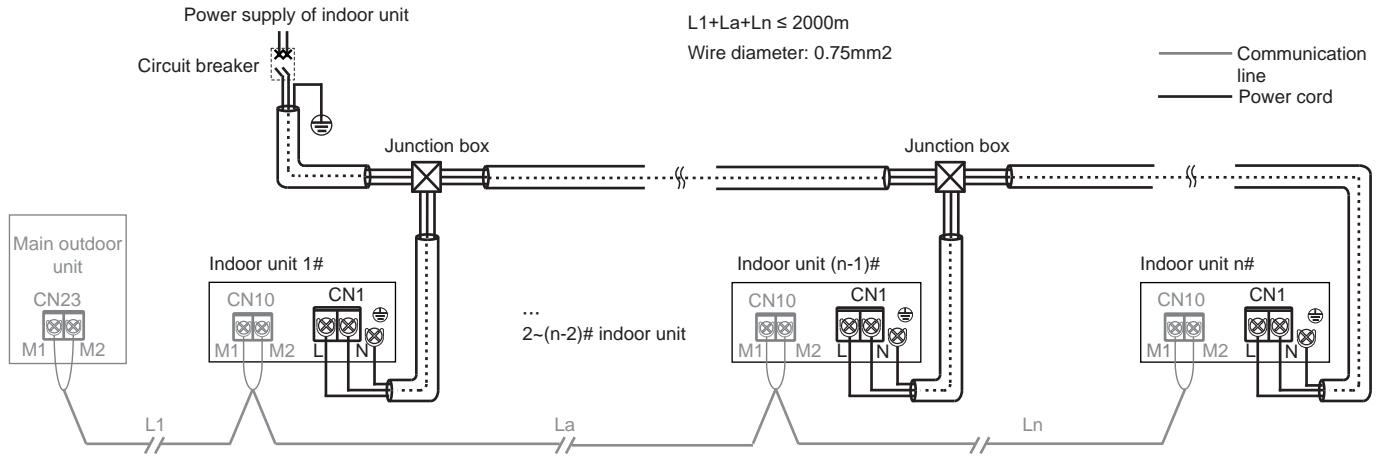

PQE communication:

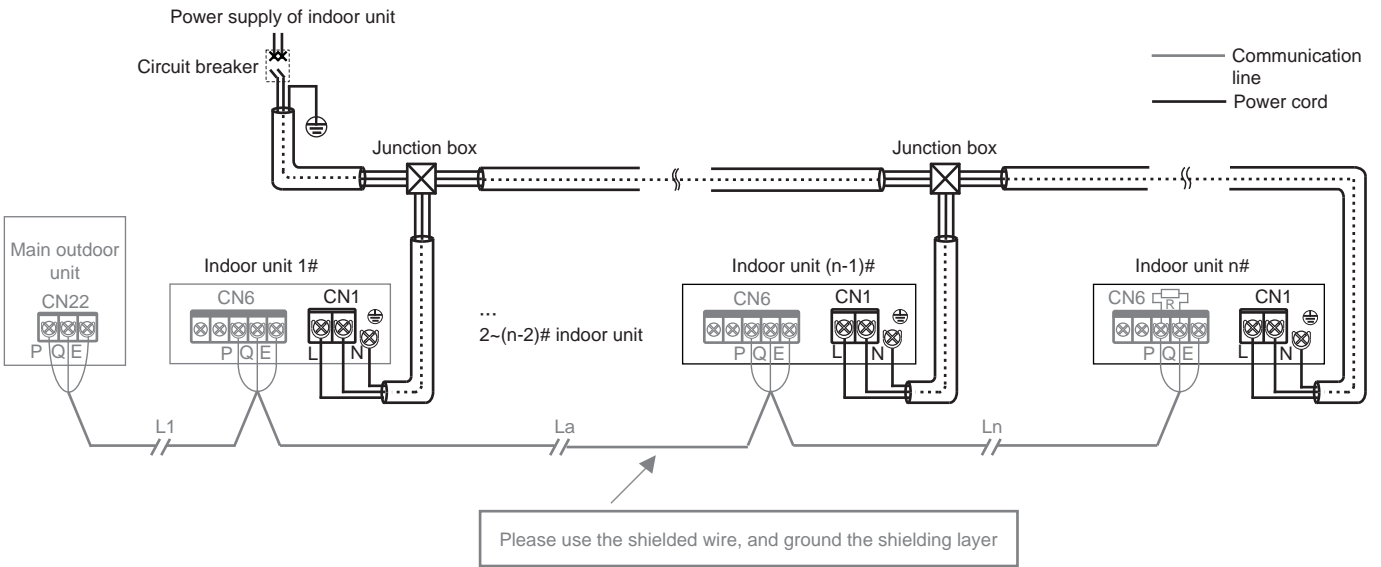

## [Caution]

In case of uniform power supply for indoor units, either EasyCom without the function of power-down control valve or PQ communication can be adopted for the communication between the indoor and outdoor units if all the indoor units in the same refrigerant system are V8 models. In case the indoor unit other than a V8 model is adopted in the same refrigerant system, only PQ(E) communication can be adopted for the communication between indoor and outdoor units.

## [Tips]

V8 indoor unit: "V8" will be on the outer carton.

Separate power supply: It enables the power supply of indoor units of the system to be controlled separately with different circuit breakers.

Uniform power supply: It requires the power supplies for all the indoor units of the system are under the control of the same circuit breaker and all the power supplies shall be switched on and off at the same time.

Function of power-down control valve: In case of power down of some indoor units in the same refrigerant system, and the main control board of the outdoor unit will continue to supply power to the indoor unit through EasyCom communication cable, so as to enable the continuous control valve of the indoor unit and ensure the stable operation of other indoor units in the system.

Repeater: It refers to a power supply repeater that is used to compensate the voltage drop caused by the overlong line or excessive line resistance when the main control board of the outdoor unit enable power-down control valve of the indoor unit through EasyCom communication cables. It is only used in the refrigerant system where separate power supply is adopted for indoor units.

## 4 Communication wire connection

### ① Communication mode selection of indoor units

The outdoor unit of V8 series platform is equipped with Easycom (M1M2) communication independently developed, and the previous RS-485 (PQE) communication is retained, which is compatible with indoor units other than V8 models. Before installing the communication line, please select the appropriate communication mode based on the indoor unit model purchased, referring to table below:

Indoor unit models of the system	Optional communication modes between indoor and outdoor units	Remarks
All indoor units in the system are V8 models	Easycom (M1M2) communication	1. Supporting separate power supply* for indoor units of the system 2. Supporting any topological connection of communication cables 3. Supporting M1M2 two-core non-polarity communication
The indoor unit other than a V8 model is adopted in the system	RS-485 (PQE) communication	1. The indoor unit of the system requires uniform power supply 2. Only hand-in-hand series connection is allowed for communication cables 3. PQE three-core communication, PQ non-polarity communication

## ② Selection reference for communication cable diameter

Function	Communication between indoor and outdoor units			One-control-one (two-control-one) communication	One-control-multiple (centralized control) communication
Type	EasyCom Communication (separate power supply for indoor units)	EasyCom Communication (Uniform power supply for indoor units)	PQE Communication (Uniform power supply for indoor units)	X1X2 communication	D1D2 communication
Wire diameter	2×1.5 mm <sup>2</sup> (shielded wires) Line resistance ≤1.33Ω/100m	2×0.75 mm <sup>2</sup> (shielded wires)	3×0.75 mm <sup>2</sup> (shielded wires)	2×0.75 mm <sup>2</sup> (shielded wires)	2×0.75 mm <sup>2</sup> (shielded wires)
Length	≤ 600m (Add two repeaters)	≤2000m	≤1200m	≤200m	≤1200m
Wire Type	Ordinary PVC sheathed flexible wire shielded		Copper core PVC insulated sheathed shielded flexible cable		
Wire standard	GB/T5023		JB/T8734		

### [Caution]

For the selection of communication lines, please refer to the requirements of the above reference table. In case of high magnetic fields or strong interference in the environment, shielded wires are recommended for all communication lines.

The field wiring must be conducted by professionals / in accordance with the relevant regulations of the local country/region.

It is forbidden to connect the communication line when the power supply is on.

It is forbidden to connect the power cord to the communication terminal. Otherwise the mainboard will be damaged.

The standard value of the screw tightening torque of the communication cable terminal block is 0.5 N.m. Too low torque may cause poor contact; Too high torque may damage screws and terminal blocks.

In case of the indoor unit other than a V8 model in the same refrigerant system, only PQE communication mode can be selected for the communication between indoor and outdoor units, with 3X0.75 mm<sup>2</sup> three-core shielded wires required to connect "P" "Q" "E".

It is forbidden to bind the communication cables with the refrigerant pipes and power cords. When the power cord is laid parallel to the communication cable, a distance of 5cm shall be maintained to prevent the signal source interference.

Communication lines shall not be bonded and connected as far as possible. If the line is not long enough, reliable connection can be ensured by wire pressing or soldering, without the copper wire at the connection exposed. Otherwise communication faults will be caused.

### ③ Communication between indoor and outdoor units

#### A EasyCom communication (separate power supply for indoor units)

Single set: EasyCom communication is a new indoor and outdoor unit communication technology. In case of separate power supply for indoor units, the communication cable of a wire diameter of 2X1.5 mm<sup>2</sup> is required, in order to enable the function of power-down control valve of indoor units. Connect the communication cables to the terminal block "CN10" on the mainboard according to the marks "M1" and "M2"; As the EasyCom communication is non-polarity communication, no one-to-one connection is required, as shown in the figure below:

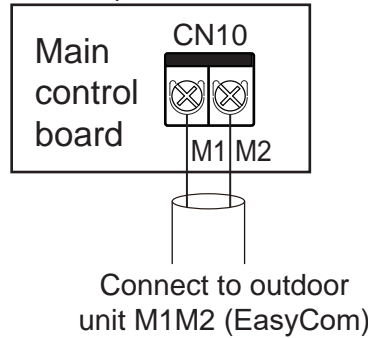

#### [Caution]

It is forbidden to connect the EasyCom communication cable to PQ or D1D2 communication.

System: EasyCom communication cables of both outdoor and indoor units with the function of power-down control valve has a total length of up to 600m, supporting any topological connection. The figure below indicates the hand-in-hand connection:

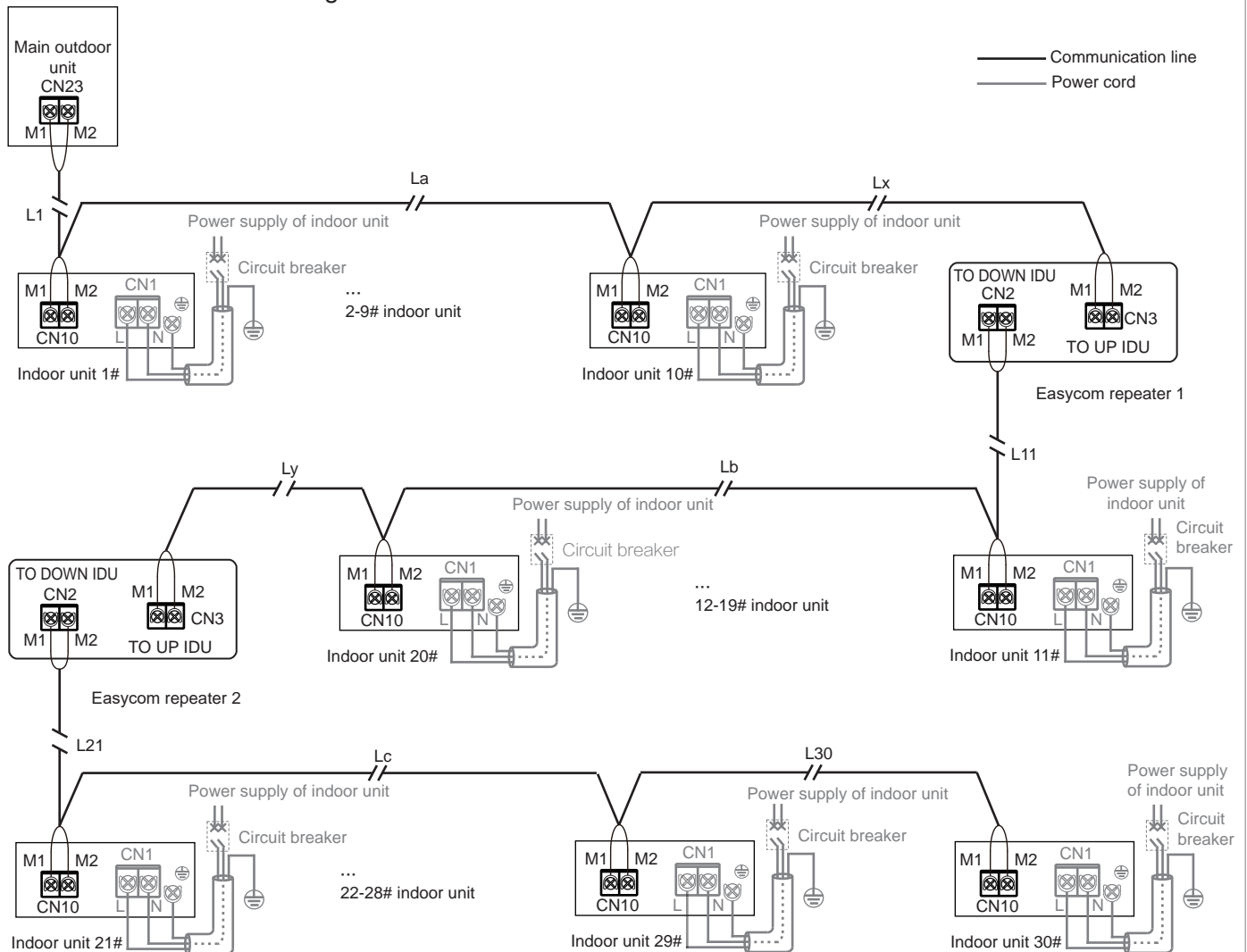

$$L1+Lx+Lz \leq 200m \quad L1+Lb+Ly \leq 200m \quad L21+Lc+L30 \leq 200m$$

For other connection modes (tree topology, star topology and ring topology), please refer to the technical manual or consult the technical personnel.

## [Caution]

In case of total distance  $\leq 200\text{m}$  and total number of indoor units  $\leq 10$  The control valve will be powered by the main outdoor unit.

In case of total distance  $> 200\text{m}$  or total number of indoor units  $> 10$  an additional repeater will be needed to increase the bus voltage.

The carrying capacity of the repeater is the same as that of the outdoor unit, with a bus length of 200m and 10 indoor units.

The number of indoor units requiring a general power supply in the same refrigerant system are  $\leq 30$  sets.

In the same refrigerant system, at most 2 repeaters are installed.

The power supply of the repeater and indoor unit shall be kept on/off at the same time, or UPS shall be used.

For the installation of the repeater, please refer to the installation instructions. It is forbidden to reversely connect the upstream indoor unit port with the downstream indoor unit port. Otherwise, communication faults will occur.

The repeater is an optional accessory. If you want it, please contact your local dealer.

## **B** EasyCom communication (uniform power supply for indoor unit)

Single set: When the indoor unit is powered uniformly, the EasyCom communication cables may not be with the function of the power-down control valve of the indoor unit. At this time, the communication cable of a wire diameter of  $2 \times 0.75 \text{ mm}^2$  is only needed. Connect the communication cables to the terminal block "CN10" on the mainboard according to the marks "M1" and "M2"; As the EasyCom communication is non-polarity communication, no one-to-one connection is required, as shown in the figure below:

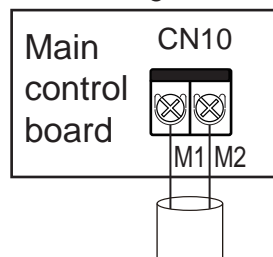

Connect to outdoor unit  
M1M2 (EasyCom)

## [Caution]

It is forbidden to connect the EasyCom communication cable to PQ or D1D2 communication .

System: EasyCom communication line of both outdoor and indoor units without the function of power-down control valve has a total length of up to 2,000m, supporting any topological connection. The following figure indicates the hand-in-hand connection:

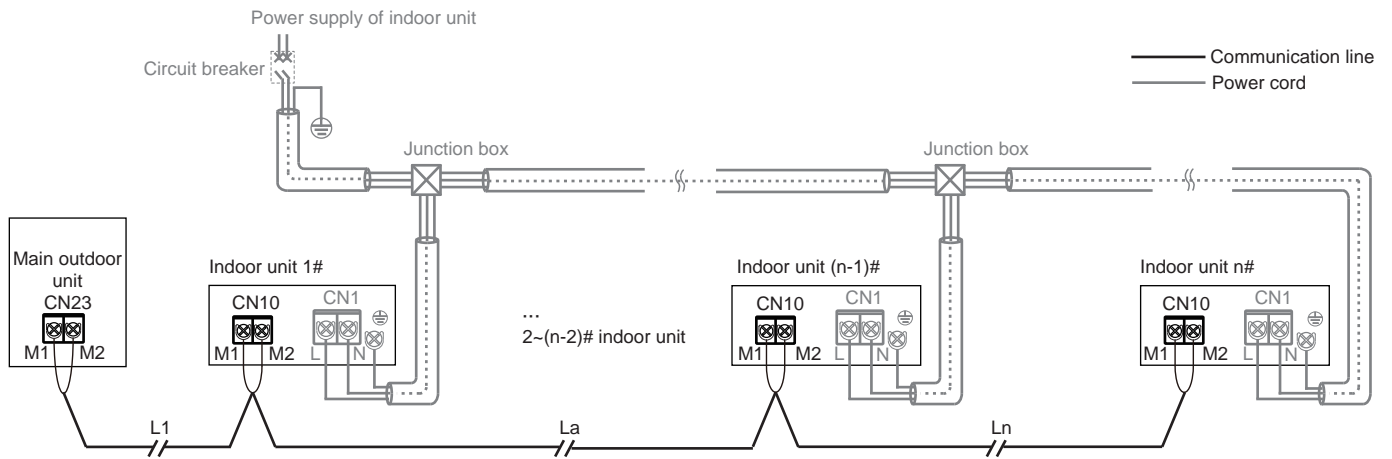

$$L1+La+Ln \leq 2000m$$

For other connection modes (tree topology, star topology and ring topology), please refer to the technical documents or consult the technician.

### [Caution]

In the case of the EasyCom communication without the function of power-down control valve, the indoor unit requires uniform power supply. Please refer to the section "Power cord connection" for details.

In the case of the EasyCom communication without the function of power-down control valve, the repeater is unnecessary for the system.

## D PQE communication (uniform power supply for indoor unit)

In the case of indoor unit other than a V8 model in the same refrigerant system, it needs to be connected to "P", "Q" and "E" for PQE communication.

Single set: The communication cables of PQE shall be shielded wire and the shielding layer shall be effectively grounded, and shall be connected to the terminal block "CN6" on the mainboard according to the marks "P", "Q" and "E". The PQ communication is non-polarity communication, and the shielding layer shall be connected to the sheet metal parts of the electric control box, as shown in the following:

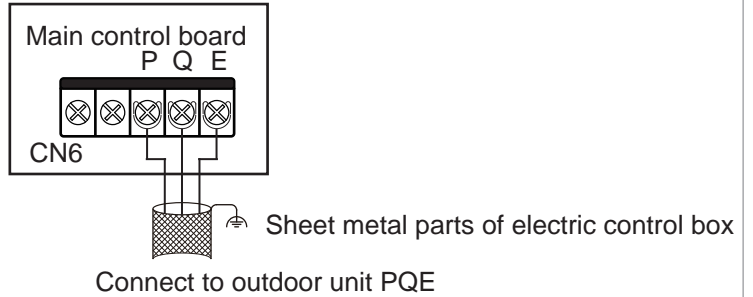

System: The total length of communication of the indoor and outdoor units of PQE can reach 1200m at most, connected hand-in-hand, as shown in the following:

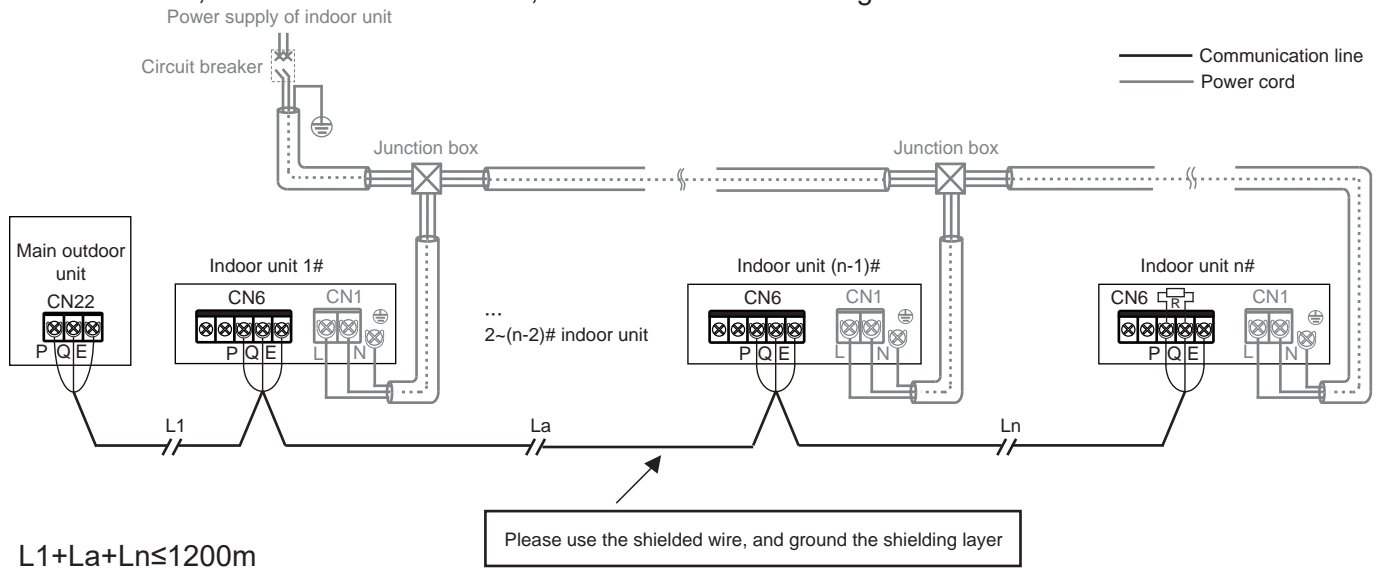

## [Caution]

In case PQ (E ) is used for communication, the indoor unit requires uniform power supply.

The communication can only be PQ(E) or EasyCom. To enable the function of power-down control valve of the indoor unit, the EasyCom communications must be used;

PQ (E ) communication cables must be shielded wires, and other wires may affect the normal communication between the indoor and outdoor units.

For the last indoor unit, a matching resistor (in the accessory bag of outdoor unit) needs to be added to PQ.

### ④ X1X2 communication cable connection

The X1X2 communication is mainly connected to the wire controller to realize the functions of one-control-one, two-control-one by the wire controller. The total length of the X1X2 communication line can reach 200m, and shielded wires are required. The shielding layer is prohibited from grounding. Connect the communication cables to the terminal block "CN6" on the mainboard according to the marks "X1" and "X2". As the wire controller communication is non-polarity communication, no one-to-one connection is required, as shown in the figure below:

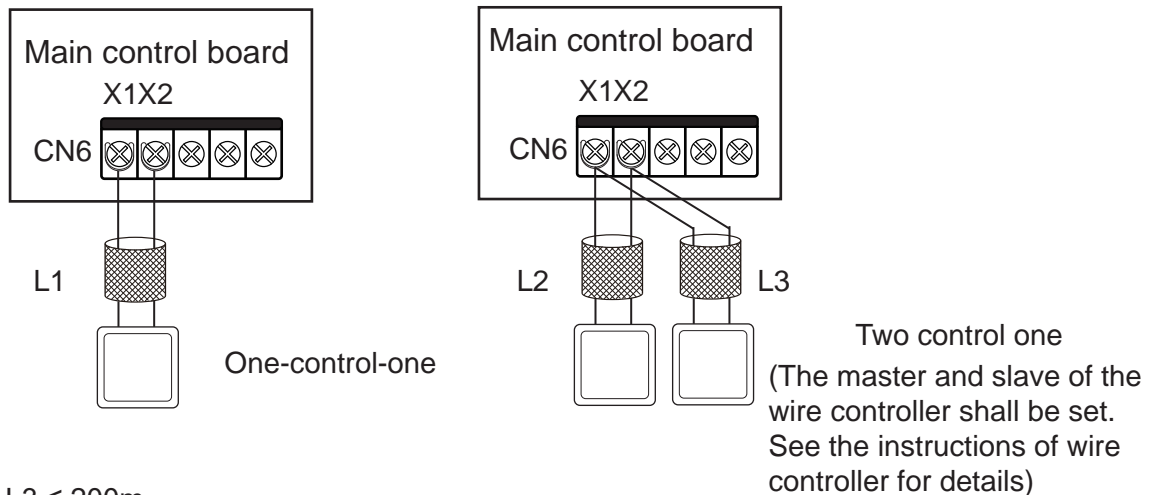

$L1 \leq 200m$  ,  $L2+L3 \leq 200m$ .

## [Caution]

Two wire controllers of the same model can be used to control one indoor unit at the same time to realize two-control-one. At this time, the master-slave relationship between the two wire controllers shall be set. Refer to the instructions for wire controllers for details.

⑤ D1D2 communication cable connection (in the case of limited outdoor unit and system configuration)

**A** D1D2 communication enables one-control-multiple and two-control-multiple functions of the indoor unit wire controller (up to 16 sets)

The D1D2 communication is 485 communication, and D1D2 can be used to realize one-control-multiple and two-control-multiple functions of the indoor unit wire controller, as shown in the following figure:

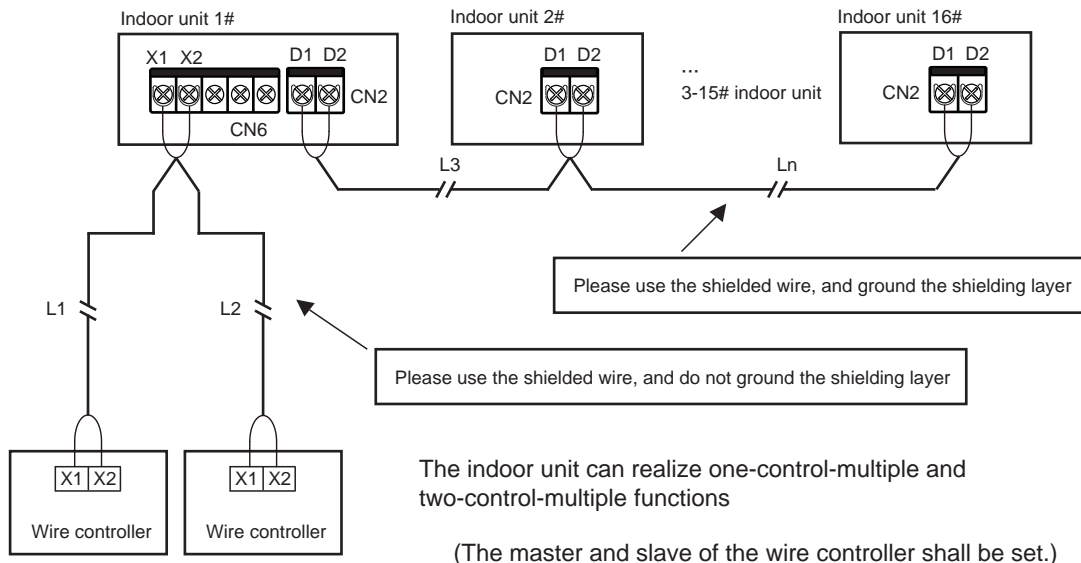

$L1+L2 \leq 200m$      $L3+Ln \leq 1200m$

**[Caution]**

When all the indoor units in the same refrigerant system are V8 type, D1D2 communication can realize one-control-multiple and two-control-multiple functions.

The two-control-multiple controllers shall be of the same model.

**B** D1D2 communication enables centralized control function of indoor unit

D1D2 can also be connected to the centralized controller to realize the centralized control function of the indoor unit, as shown in the following figure:

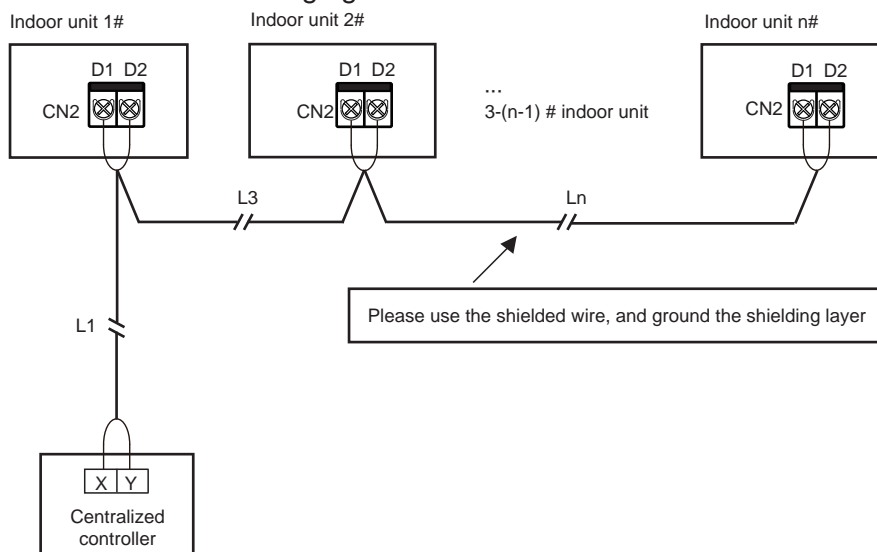

$L1+L3+Ln \leq 1200m$

## 5 External connection board wiring (in the case of limited outdoor unit and system configuration)

The external connection board is the connection module outside the main board, including display components, function module adapter board, free function module 1 and free function module 2. Those are all optional modules.

### ① Display component connection

The display component is connected to the "CN30" socket of the main control board through 4-core communication cables, as shown in the figure below:

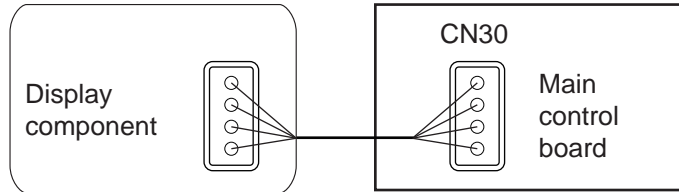

### ② Connection of function module adapter board

The free function module communicates with the main control board through the function module adapter board. Either select free function module 1 or 2 separately, or select both of the modules at the same time. The wiring diagram is as follows:

#### Only free function module 1

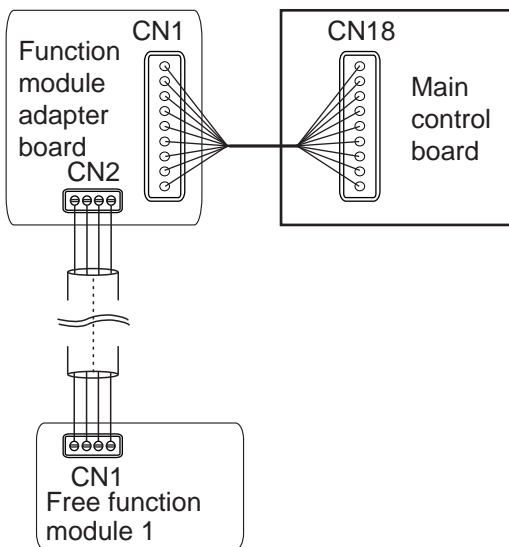

#### Free function module 2 only

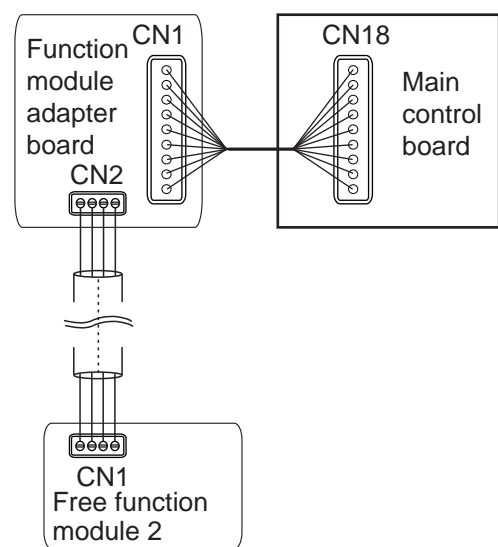

#### Both free function modules 1 and 2

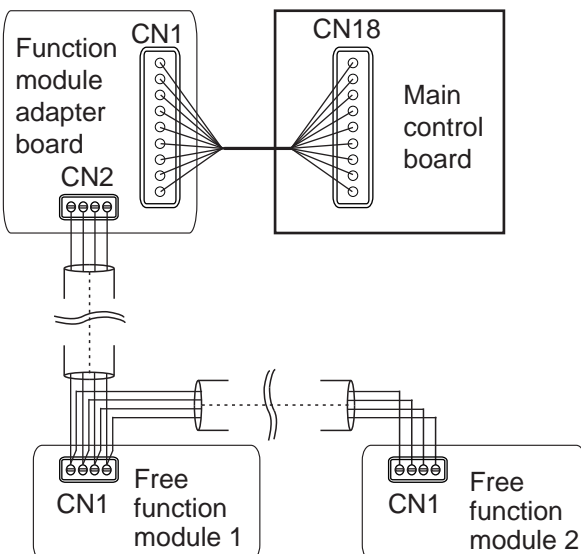

### [Caution]

For the function introduction of function module adapter board, free function module 1 and 2, please see the function module specification.

## 6 Alarm signal output, strong current sterilization connection (customized)

The alarm signal output and strong current sterilization wiring seat are fixed on the main board, connecting to the "CN22" socket. For the connection, refer to the schematic diagram, and they share a zero line as shown in the following figure:

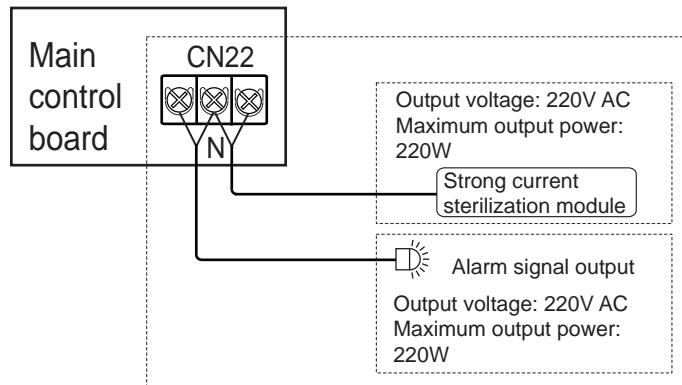

### [Caution]

Alarm signal output and strong current sterilization are customized functions.

## 7 Remote ON/OFF signal wiring (customized)

The wiring socket of the remote ON/OFF signal is fixed on the main board with the number of "CN55". Connect the terminals 1 and 2 to finish the connection (the third terminal is not functional) according to the identification on the main board, as shown in the following figure:

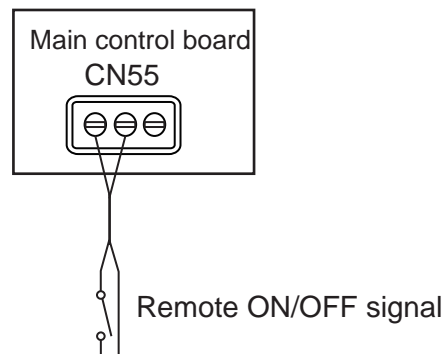

## 8 Re-cover the electric control box

Straighten and level the connecting wires, and re-cover the electric control box.

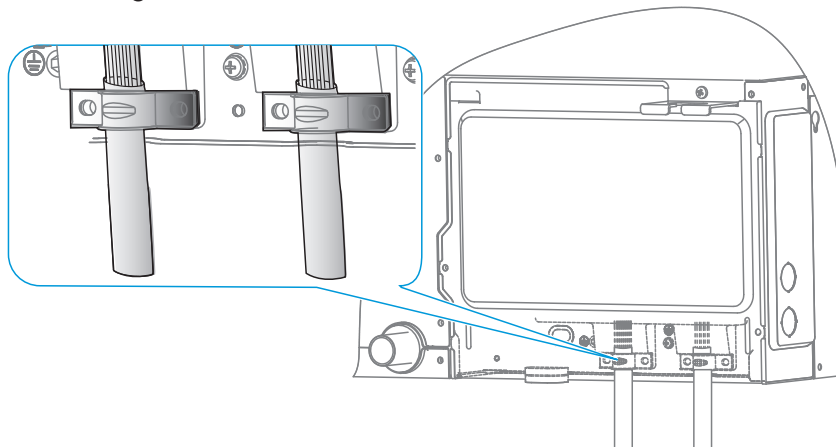

### [Caution]

Do not cover the electric control box while it is powered on.

Note the wires to prevent disorder when covering the electric control box. Do not clamp the connecting wire on the electric control box cover.

# 10 Application Control

## Error codes and definitions

In case of the following circumstances, please stop the air conditioner immediately, cut off the power switch and contact the local air conditioner customer service center. The error code is displayed on the display panel and the wired controller display.

Code	Definition	Digital tube display
A01	Emergency shut down	A01
A11	R32 refrigerant leakage, immediate shutdown	A11
A51	Outdoor unit failure	A51
A71	After the failure of the linked new fan, it will be transmitted to the main indoor unit.(series connection setting)	A71
A72	After the linkage humidification indoor unit fails, it is transmitted to the main indoor unit.	A72
A73	After the failure of the linked new fan, it will be transmitted to the main indoor unit.(non-series connection setting)	A73
A74	AHU Kit slave is transmitted to the master after failure	A74
A81	Self-checking failure	A81
A82	MS box Error	A82
A91	Mode conflict (using V6 communication protocol)	A91
b11	1# Electronic expansion valve coil failure	b11
b12	1# electronic expansion valve failure	b12
b13	2# Electronic expansion valve coil failure	b13
b14	2# Electronic expansion valve failure	b14
b34	1# Pump blocking protection	b34
b35	2# Pump blocking protection	b35
b36	Water level switch alarm	b36
b71	Rethermoelectric heating failure	b71
b72	Preconditioning electric heater failure	b72
b81	Humidifier failure	b81

Code	Definition	Digital tube display
C11	The address code of the indoor unit is repeated	001
C21	Communication error between indoor and outdoor units	021
C41	Communication error between the main control board of the indoor unit and the fan driver board	041
C51	Communication error between the indoor unit and the controller	051
C52	Communication error between the indoor unit and the Wi-Fi Kit	052
C61	Communication error between the indoor unit main control board and display board	061
C71	Communication error between the slave AHU Kit and the host	071
C72	AHU Kit quantity inconsistent with settings	072
C73	Communication error between the combined humidifier indoor unit and the main indoor unit	073
C74	Communication error between the linkage new fan and the main indoor unit (series connection setting)	074
C75	Communication error between the linkage new fan and the main indoor unit (non-series connection setting)	075
C76	Communication error between master controller and slave controller	076
C77	Communication error between the main control board of the indoor unit and 1# function expansion board	077
C78	Communication error between the main PCB of the indoor unit and 2# function expansion board	078
C79	Communication error between the main PCB of the indoor unit and the conversion board	079
d16	Inlet air temperature of the indoor unit in heating operation is too low	216
d17	Inlet air temperature of the indoor unit in cooling operation is too high	217
d81	Temperature and humidity alarm out of range	281
dE1	The sensor control board failure	2E1
dE2	PM2.5 sensor failure	2E2
dE3	CO2 sensor failure	2E3
dE4	Formaldehyde sensor failure	2E4
dE5	Smart eye sensor failure	2E5
E21	T0-Fresh air inlet temperature sensor short circuit or break	E21
E22	The dry bulb temperature sensor(upper) is short-circuited or disconnected	E22

Code	Definition	Digital tube display
E23	The dry bulb temperature sensor (lower) shed is short-circuited or disconnected	E23
E24	T1-indoor unit return air temperature sensor short-circuited or disconnected	E24
E31	Room temperature sensor in the wire controller short-circuit or disconnection	E31
E32	Wireless temperature sensor short-circuited or disconnected	E32
E33	External room temperature sensor short-circuited or disconnected	E33
E61	Tcp-fresh air temperature sensor after precooling short-circuited or disconnected	E61
E62	Tph-fresh air temperature sensor after preheating short-circuited or disconnected	E62
E81	TA-air outlet temperature sensor short-circuited or disconnected	E81
EA1	Air outlet humidity sensor failur	EA1
EA2	Return air humidity sensor failure	EA2
EA3	The wet bulb sensor(upper) failure	EA3
EA4	The wet bulb sensor (lower) failure	EA4
EC1	R32 refrigerant leak sensor failure	EC1
F01	T2A-heat exchanger inlet temperature sensor short circuit or disconnect	F01
F11	T2-temperature sensor in the middle of heat exchanger short circuit or disconnect	F11
F12	T2 -temperature sensor in the middle of heat exchanger overtemperature protection	F12
F21	T2B -temperature sensor in heat exchanger short circuit or disconnect	F21
P71	EEPROM of the main PCB failure	P71
P72	EEPROM of the display board of the indoor unit failure	P72
U01	Not unlocked (electronic lock)	U01
U11	The model code not set	U11
U12	HP not set	U12
U14	HP setting error	U14
U15	DIP switch of the AHU Kit fan control input signal is incorrectly set	U15
U38	No address code detected	U38

Code	Definition	Digital tube display
J01	Multiple motor failures	001
J1E	IPM fan module overcurrent protection	01E
J11	Phase current transient overcurrent protection	011
J3E	Low bus voltage failure	03E
J31	Excessive bus voltage failure	031
J43	The sampling value of the phase current is abnormal	043
J45	Motor does not match indoor machine model	045
J47	IPM does not match the indoor unit model	047
J5E	Motor startup failure	05E
J52	Motor blocking protection	052
J55	The speed control mode is incorrectly set	055
J6E	Motor lack of phase protection	06E

## Non-error codes and definitions

Code	Definition	Digital tube display
d0	Oil return or preheating running	00
dC	Self-cleaning running	0C
dd	Mode conflict (using V8 communication protocol)	0d
dF	Defrost running	0F
d51	Static pressure detection	051
d61	Remote shutdown	061
d71	Indoor unit is in Backup operation	071
d72	Outdoor unit is in Backup operation	072
OTA	Master program upgrade operation	0tA

## Spot check description

The two-way communication wire controller (taking KJR-86S/BK as an example) is used to query the spot check function. The steps are as follows:

- ① In the main interface, press and hold "≡" and "▲" keys for 2 seconds to enter the query interface. The outdoor unit screen will display u00-u03, the indoor unit screen will display n00-n63 (the last two digits are the indoor unit address), and the wire controller screen will display "CC". Press "▲" and "▼" to select the corresponding indoor unit address, and press "↵" key to enter parameter query.
- ② Press "▲" and "▼" again to query parameters, and parameters can be queried circularly. See the checklist below for details.
- ③ Press "⌚" to exit the query function.
- ④ The "Timing area" at the top of the query interface displays the spot check serial number, and the "Temperature area" displays the spot check parameters.

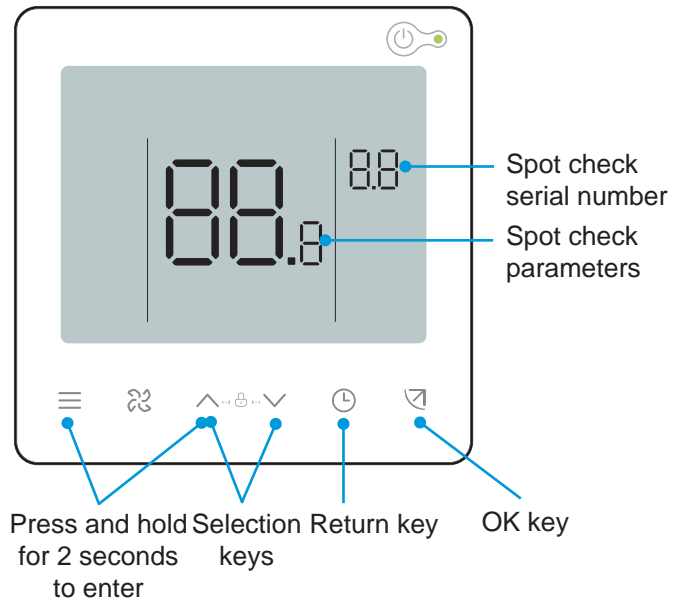

S/N	Display contents	S/N	Display contents
1	Correspondence address of indoor and outdoor units	11	Actual RH Indoor humidity
2	Capacity of indoor unit	12	Actual fresh air fan TA supply air temperature
3	Actual set temperature Ts	13	Jet pipe temperature
4	Set temperature for current operation Ts	14	Exhaust temperature of compressor
5	Actual T1 indoor temperature	15	Target overheat
6	Modified room temperature T1_m o d i f y	16	EXV opening (actual opening/8 )
7	Actual T2 heat exchanger middle temperature	17	Software version No.
8	Actual T2A heat exchanger liquid tube side temperature	18	Historical fault code (most recently)
9	Actual T2B heat exchanger tube side temperature	19	Historical fault code (more recently)
10	Actual setting humidity RHs	20	Display [ ——— ]

## External static pressure setting

The external static pressure is set by the wire controller with two-way communication (taking KJR-86S/BK as an example), including the following two cases:

### 1 Constant airflow mode

For the indoor unit with constant airflow function, constant airflow is the factory default. After installation, the initial static pressure test is required for its use at the first time. The steps are as follows:

- ① In the main interface, press and hold the "☰" + "↵" keys for 3 seconds to enter the query interface, the outdoor unit screen will display u00-u03, the indoor unit screen will display n00-n63 (the last two digits are the indoor unit address), and the wire controller screen will display "CC". Press the "▲" key and "▼" key to select the corresponding indoor unit address, and press the "↵" key to enter the parameter setting interface, the main interface of the wire controller will display "n00"..
- ② After entering the parameter setting interface, press "▲" and "▼" to switch the "parameter code" to the initial static pressure test "n58", press "↵" to enter the specific parameter setting, and then press "▲" and "▼" to set the parameter to "01" and press "↵" to complete the setting, and the wire controller will send the initial static pressure test command to the indoor unit. Wait for a few minutes to complete the initial static pressure test of the indoor unit.
- ③ Press the "⌚" key to return to the previous layer until exit the parameter setting or exit 60 seconds after no operation.

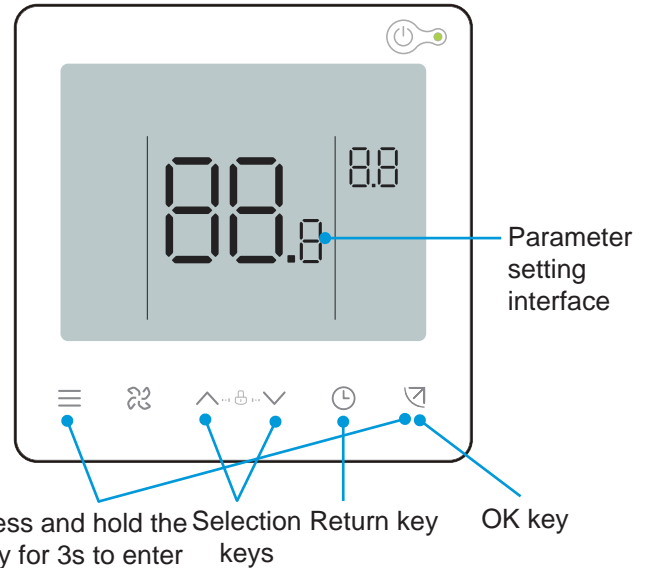

Parameter code	Parameter name	Parameter range	Default value	Remarks
n58	Initial static pressure test	00/01	00	00 : not reset; 01: reset

# Wind pressure curve

## Constant airflow - adaptive

CNT2-3-XY D15

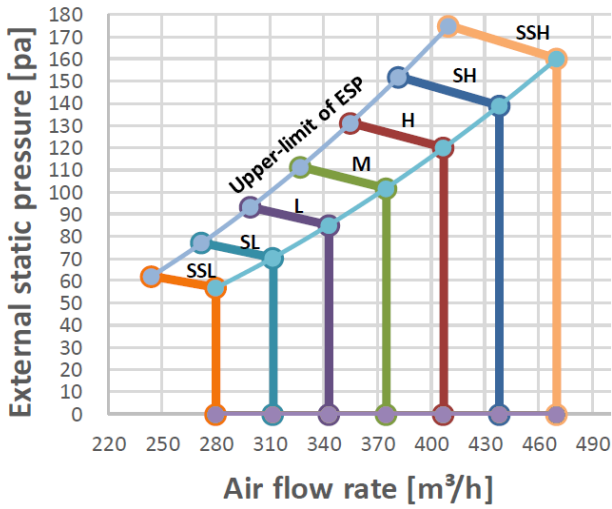

CNT2-3-XY D22

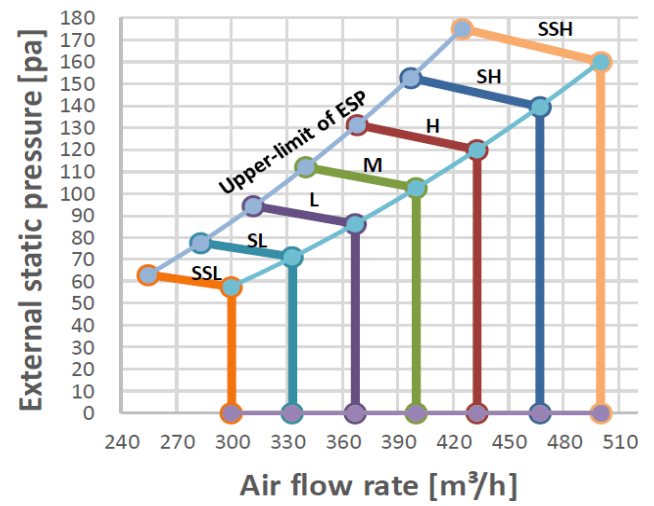

CNT2-3-XY D28

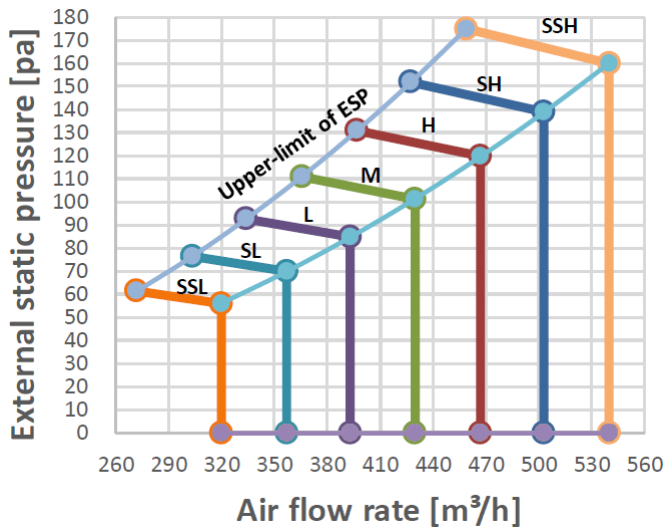

CNT2-3-XY D36

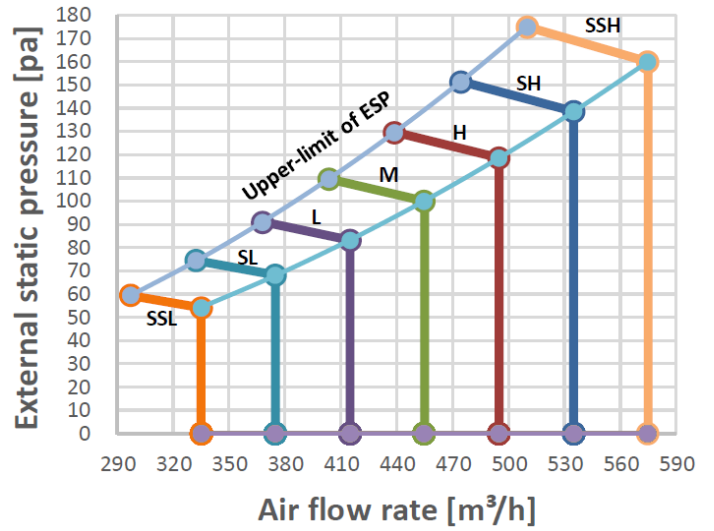

CNT2-3-XY D45

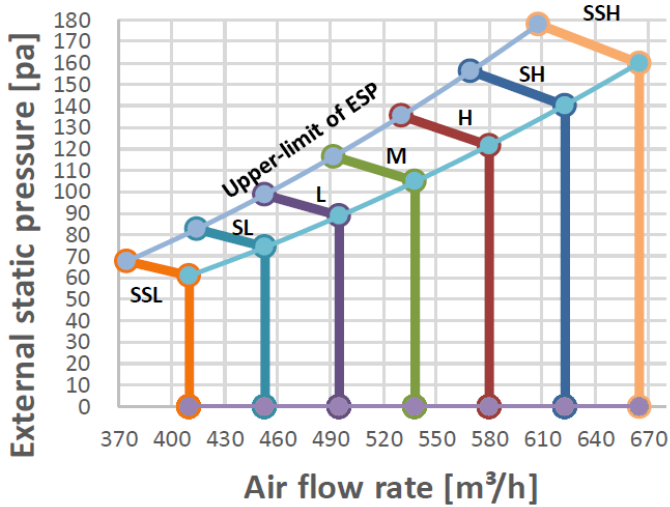

CNT2-3-XY D56

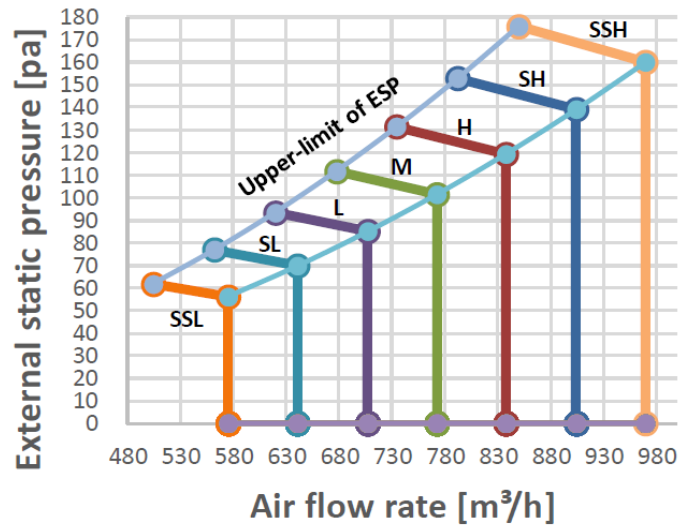

CNT2-3-XY D71

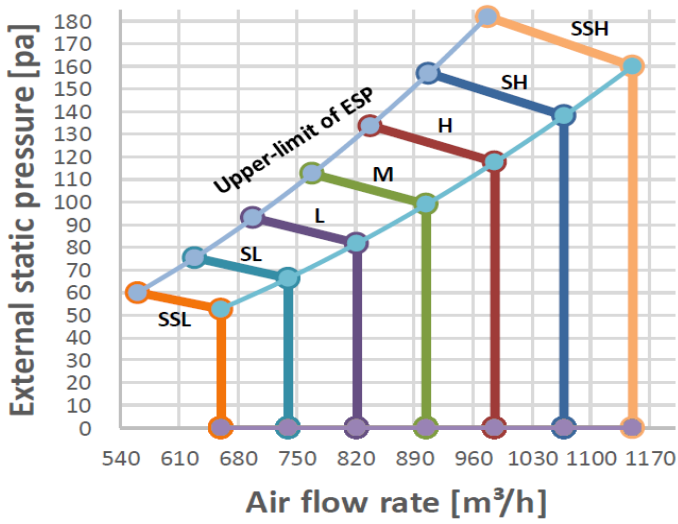

CNT2-3-XY D80

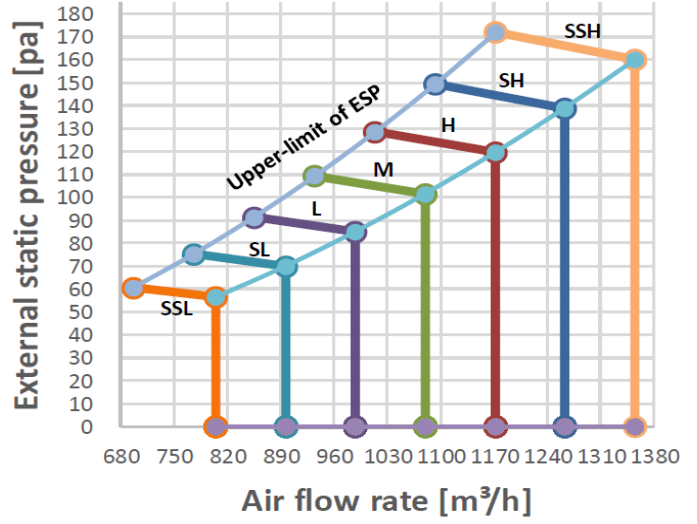

CNT2-3-XY D90

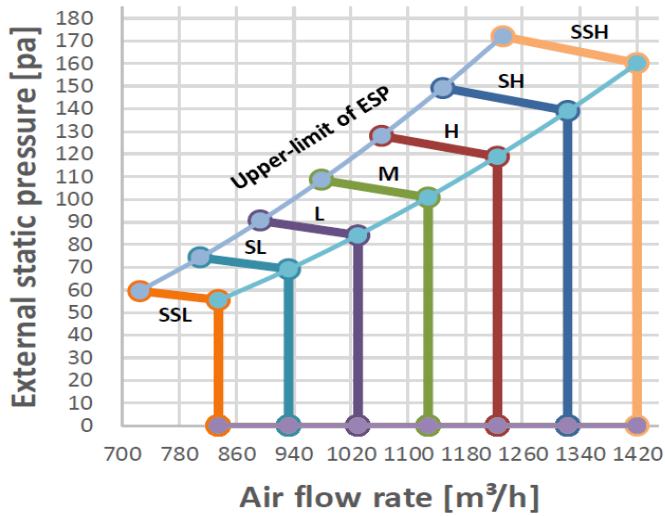

CNT2-3-XY D112

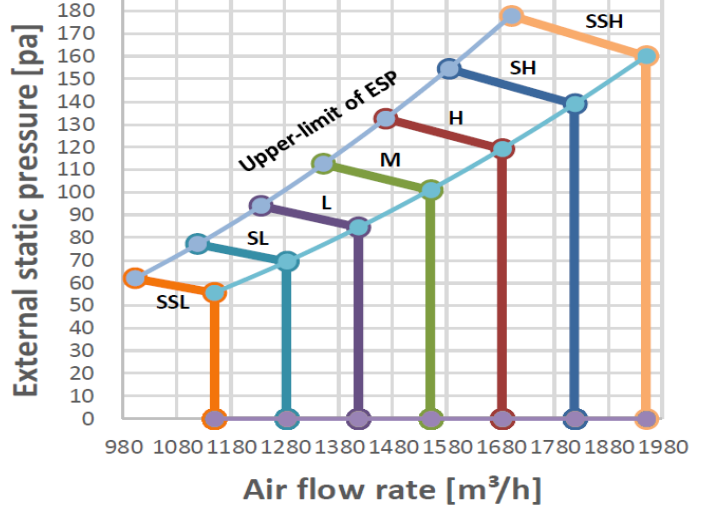

CNT2-3-XY D125

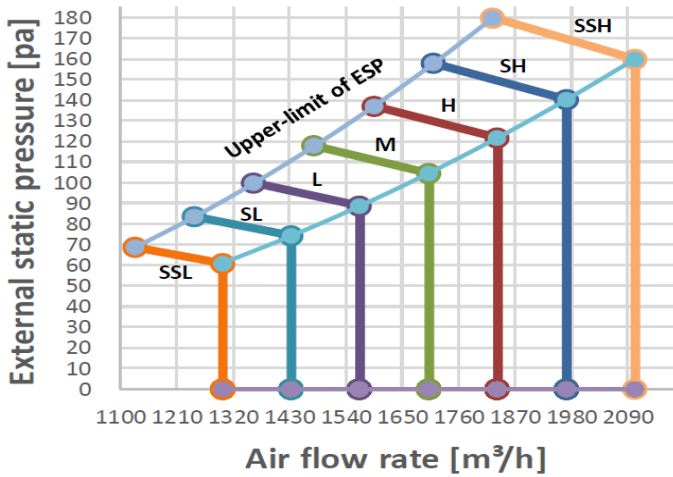

CNT2-3-XY D140

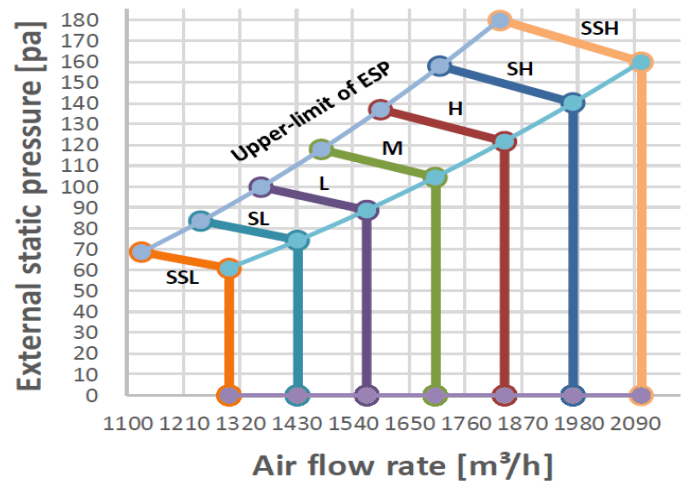

CNT2-3-XY D140

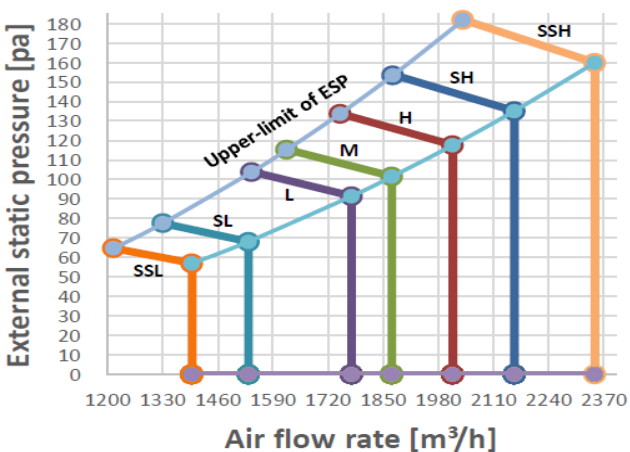

**[Caution]**

When the actual installed static pressure is within 160Pa, the air volume is constant; After it exceeds 160Pa, the air volume begins to attenuate, and it is not recommended to install this type of machine outside this static pressure range on the oblique line.

SSL, SL, L, M, H, SH and SSH represent airflow from gears 1 to 7 respectively.

## 2 Constant speed mode

The two-way communication wire controller is required to set the external static pressure parameters to overcome the air outlet resistance. The steps are as follows:

- ① In the main interface, press and hold the "☰" + "↵" keys for 3 seconds to enter the query interface, the outdoor unit screen will display u00-u03, the indoor unit screen will display n00-n63 (the last two digits are the indoor unit address), and the wire controller screen will display "CC". Press the "▲" key and "▼" key to select the corresponding indoor unit address, and press the "↵" key to enter the parameter setting interface, the main interface of the wire controller will display "n00".
- ② After entering the parameter setting interface, the main interface of wire controller will display "n00", press "↵" to enter the specific parameter setting, then press "▲" and "▼" to adjust the parameter value of the external static pressure gear, and press "↵" to save the parameters. In this case, the setting of external static pressure parameters is completed.
- ③ Press the "⌚" key to return to the previous layer until exit the parameter setting or exit 60 seconds after no operation.

Parameter code	Parameter name	Parameter range	Default value	Remarks
n00	External static pressure	External static pressure gear: 02/04/06/07/08/09/~19	06(1.5~7.1kW) 07(8.0~11.2kW) 08(12.5~16.0kW)	Indoor unit is set according to gears Corresponding static pressure value FF

### Static pressure setting parameter list

Machine capability	Static pressure setting															
	02 Position	04 Position	06 Position	07 Position	08 Position	09 Position	10 Position	11 Position	12 Position	13 Position	14 Position	15 Position	16 Position	17 Position	18 Position	19 Position
HP	Pa	Pa	Pa	Pa	Pa	Pa	Pa	Pa	Pa	Pa	Pa	Pa	Pa	Pa	Pa	Pa
W*100																
15(0.6HP)																
22(0.8HP)																
28(1.0HP)																
36(1.2HP)																
45(1.7HP)																
56(2.0HP)	10	20	30	40	50	60	70	80	90	100	110	120	130	140	150	160
71(2.5HP)																
80(3.0HP)																
90(3.2HP)																
112(4.0HP)																
125 (4.5HP)																
140 (5.0HP)																
160(5.7HP)																

# Wind pressure curve

## Non-constant airflow

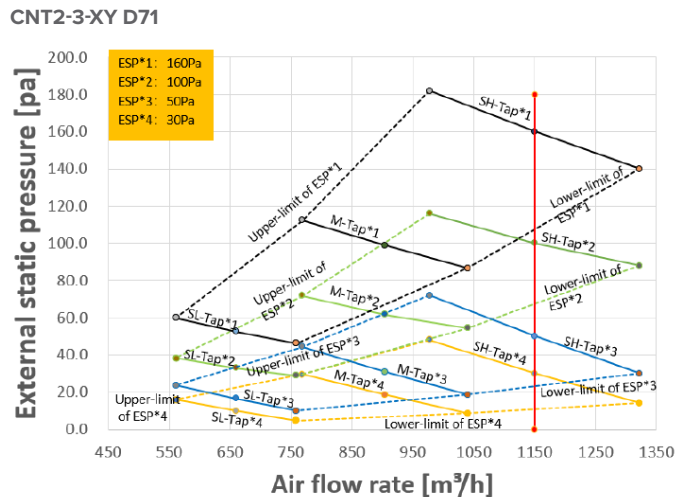
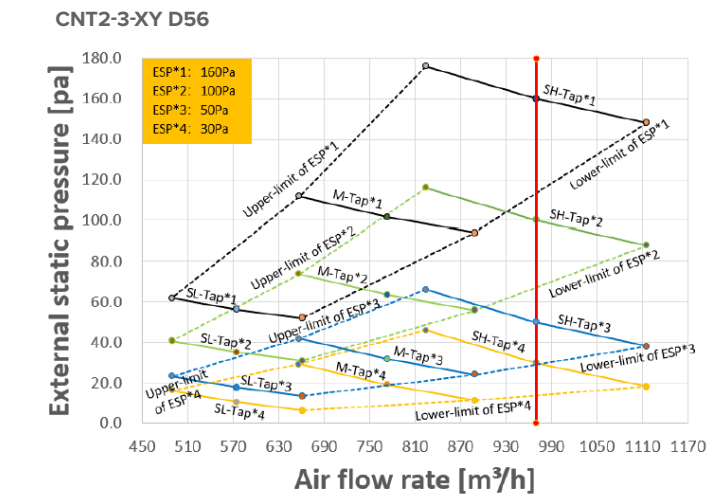
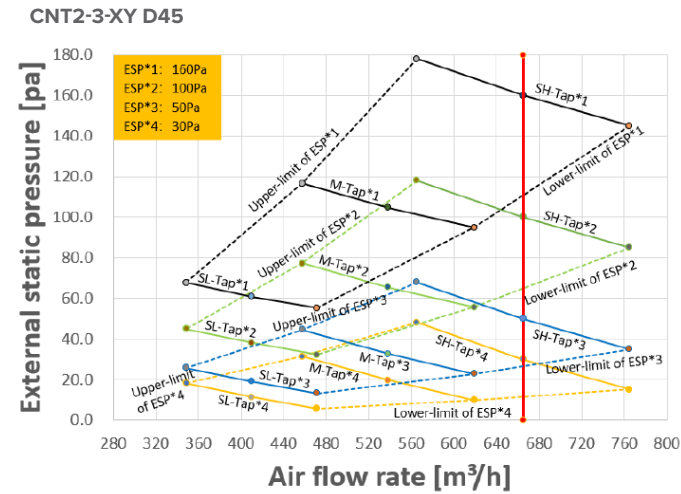
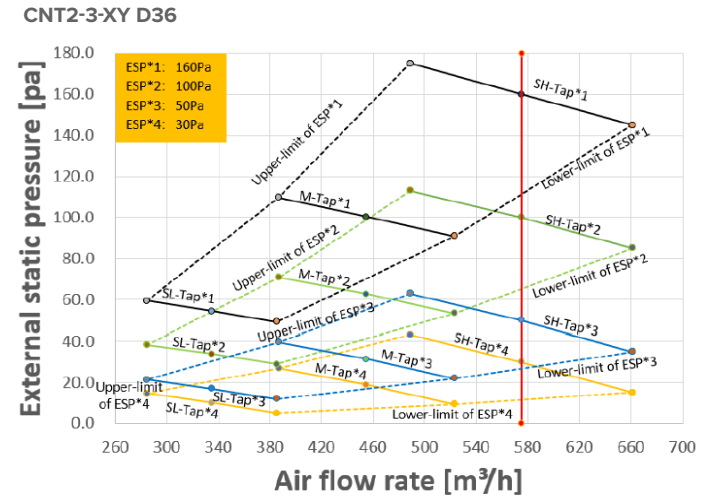
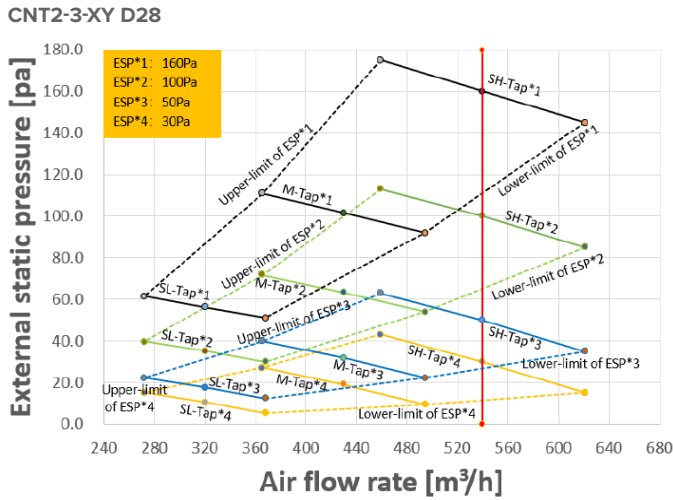
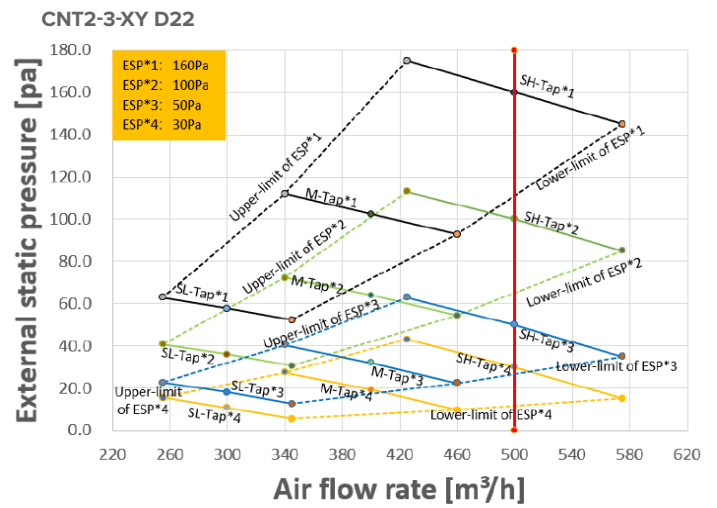
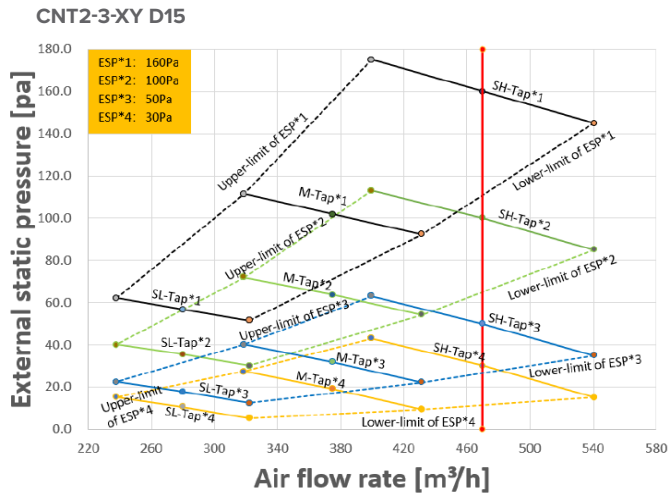

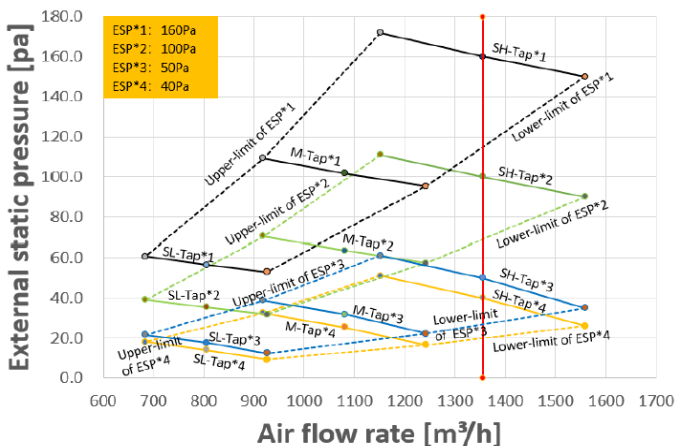
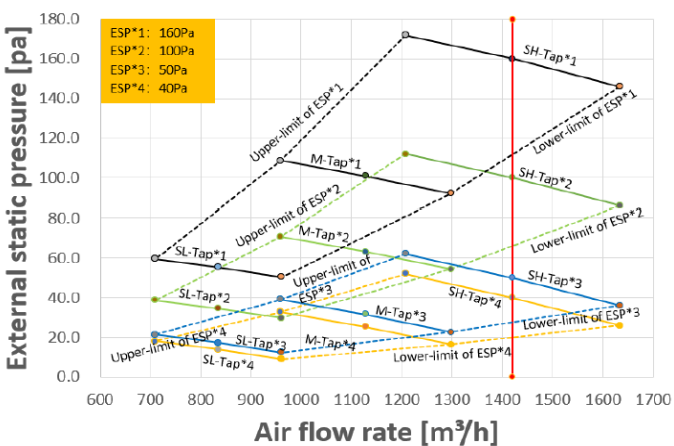
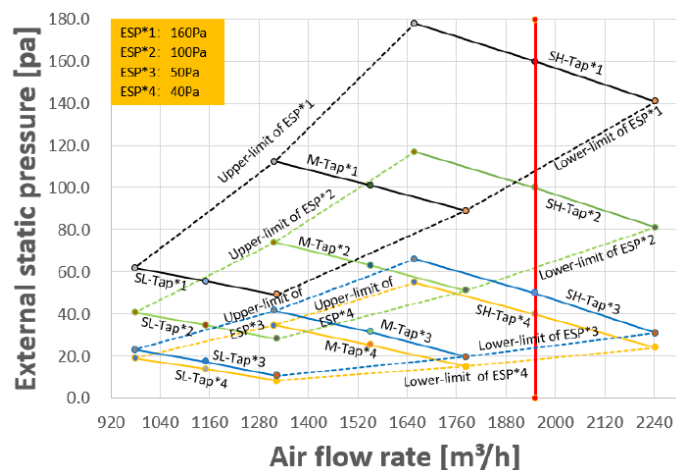
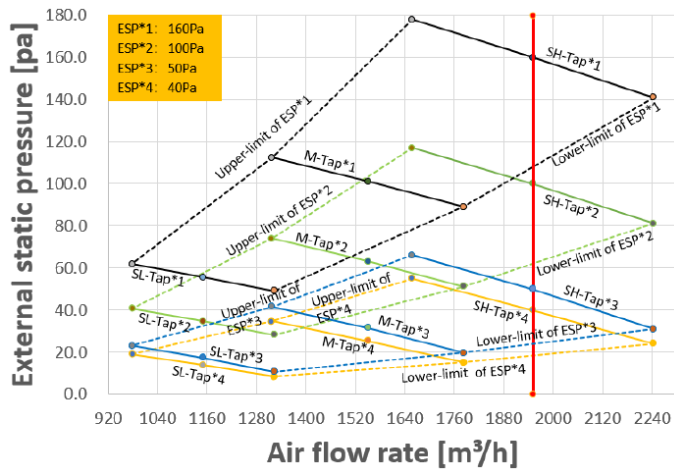
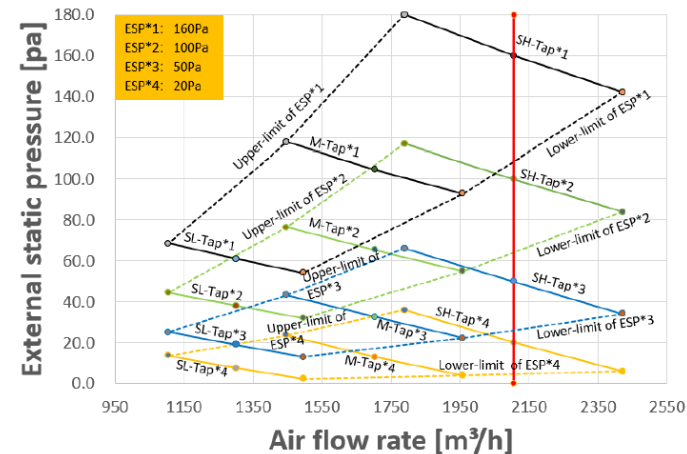
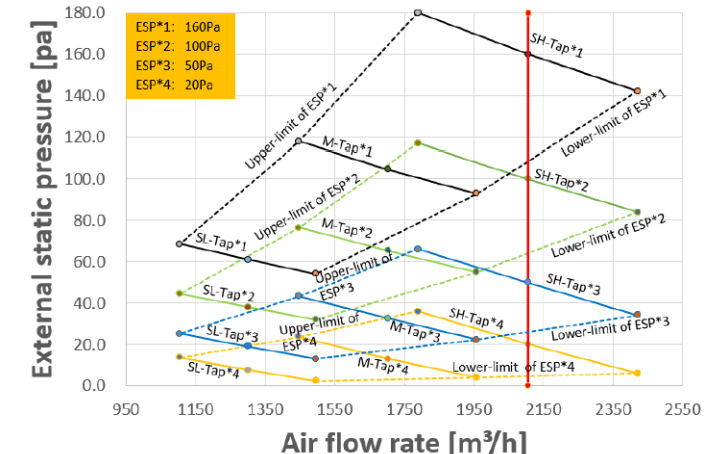
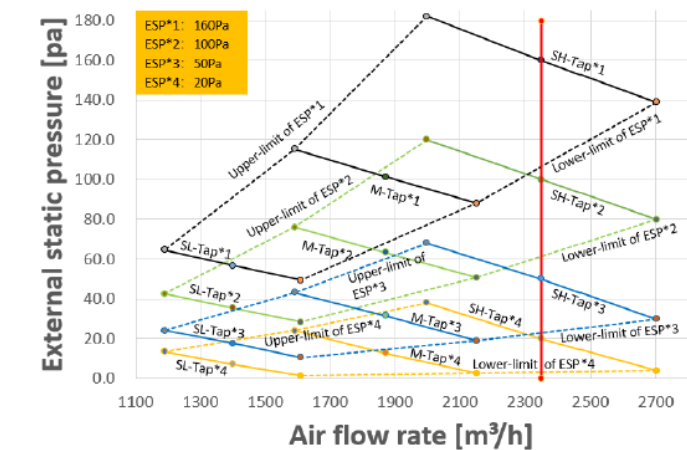
**CNT2-3-XY D80****CNT2-3-XY D90****CNT2-3-XY D112****CNT2-3-XY D112****CNT2-3-XY D125****CNT2-3-XY D140****CNT2-3-XY D160**

### 3 Mode switching between constant airflow and constant speed

The switching steps of the two operation modes are as follows:

- ① In the main interface, press and hold the "≡" + "↶" keys for 3 seconds to enter the query interface, the outdoor unit screen will display u00-u03, the indoor unit screen will display n00-n63 (the last two digits are the indoor unit address), and the wire controller screen will display "CC". Press the "▲" key and "▼" key to select the corresponding indoor unit address, and press the "↶" key to enter the parameter setting interface, the main interface of the wire controller will display "n00".
- ② After entering the parameter setting interface, press "▲" and "▼" to switch the "parameter code" to the constant airflow setting parameter code "n30", press "↶" to enter the specific parameter setting, then press "▲" and "▼" to adjust to the demand mode parameter value, and press "↶" to save the parameter to complete the operation mode parameter setting.
- ③ Press "⌚" key to return to the previous layer until exit the parameter setting or exit 60 seconds after no operation.

Parameter code	Parameter name	Parameter range	Default value	Remarks
n30	Constant airflow setting	00/01	01	00 : constant rotating speed; 01: constant airflow

#### [Caution]

Parameters can be set in the ON or OFF status.

In the parameter setting interface, the wire controller does not respond to the remote control signal; The wire controller does not respond to the app remote control signals.

In the parameter setting interface, the mode, airflow rate and switch buttons are invalid.

See the instructions of wire controller for details of remote controller setting parameters.

See the instructions of wire controller for other parameters of indoor unit.

## 11 Test run

### Precautions before test run

- Check whether the indoor and outdoor units are installed correctly.
- Check whether the piping is correct and whether the refrigerant pipeline system has been detected for leakage.
- Check whether the length of piping and additional amount of refrigerant have been recorded.
- Check whether the wiring is correct and firm without virtual connection; whether the grounding wire is correctly connected.
- Check whether the supply voltage is equal to the rated voltage of the air conditioner.
- Check whether the thermal insulation has been improved.
- Check whether there are obstacles at the air inlet and outlet of indoor and outdoor units.
- Fully open the air pipe and liquid pipe stop valves of the outdoor unit.
- Power on and preheat the outdoor unit for 12h.

### Test run

Control the air conditioner for cooling or heating operation with a wire/remote controller, and operate it according to the instructions. In case of any fault, please troubleshoot according to the "Non-air Conditioner Fault" part of the Operation Part in this instructions.

#### [Caution]

Operate according to the test run method of outdoor unit.

## Indoor unit

- Check whether the wire/remote control switch is normal.
- Check whether the wire / remote control display is normal, whether the function keys are normal, whether the room temperature regulation is normal, and whether the airflow and direction regulation are normal.
- Check whether the indicator lamp is on normally.
- Check whether the drainage is normal.
- Check indoor units one by one for normal operation, cooling or heating, vibration and abnormal sound.

## Outdoor unit

- Check whether there is vibration and abnormal sound during operation.
- Check whether the generated wind, noise and condensate affect neighbors.
- Check whether the refrigerant leaks.

## Check points after installation

To ensure a comfortable indoor environment for users, please read the following installation points carefully, and confirm whether the installation of air conditioner meets the requirements. Please tick "√" for the items meeting the requirements and "X" for those failing to meet the requirements.

Check item	Possible consequences if it is improper	Qualified or not
Check whether the indoor unit and outdoor unit are installed firmly	Falling, vibration and noise of air conditioner	
Check whether the installation of indoor unit has been completed	The machine does not work properly or parts are burnt	
Whether it is checked for air leakage	Lack of cold air or hot air	
Whether the heat insulation is good (refrigerant piping, drainage pipe and air duct)	Condensate dripping	
Check whether all orifices of copper pipes have been sealed before installation to prevent dust	Compressor fault	
Check whether the refrigerant pipe is filled with nitrogen for shielded welding during welding (with nitrogen cylinder on site)	A large number of oxide films are formed on the inner surface of the copper pipe, and the poor system operation leads to major faults	
Check whether drainage test is carried out, whether the drainage is smooth, and whether the connecting pipe is firm	Water leakage	
Check whether the supply voltage is in line with the rated voltage of the air conditioner.	The machine does not work properly or parts are burnt	
Check whether the wires and piping are correctly connected	The machine does not work properly or parts are burnt	
Check whether the air conditioner is safely grounded	It's very dangerous in case of electric leakage	
Check whether the power cord and connecting wire of specified specification are used	The machine does not work properly or parts are burnt	
Confirm whether the binding screw is loose	Electric shock or fire	
Check whether the air inlet and outlet of indoor unit and outdoor unit are blocked	Lack of cold air or hot air	
Set the indoor unit in constant speed mode, and check whether the external static pressure has been set	No cooling or heating	
Check whether the refrigerant piping length and refrigerant filling amount are recorded	The refrigerant volume in the air conditioning system is unknown	
Check whether an access panel is reserved for the indoor unit installation position	Difficulty in repair and maintenance	
Check whether the air filter screen and grille (air inlet and outlet) are installed	The machine doesn't work properly	
Check whether the temperature in each room can meet the requirements during commissioning	Failure to meet user comfort requirements	
Whether the operation method is explained to the user according to the Operation Part of this instructions	Poor use effect	
Whether the operation method and cleaning method of the air filter screen and grille (air inlet and outlet) are explained to the user	Poor use effect	

# Maintenance and Service

## 1 Safety Warnings

### [Warning]

For safety, be sure to shut down and cut off the power supply before cleaning the air conditioner.

Do not remove or repair the air conditioner by yourself; otherwise, fire or other dangers may occur.

Maintenance can only be carried out by professional maintenance personnel.

Do not use flammable and explosive materials (such as hairspray or insecticide) near this product.

Do not use paint thinner or other organic solvents to clean the product, as this may cause cracks, electric shock or fire.

Optional accessories must be installed by qualified agents and professionally qualified electricians.

Be sure to use the optional accessories designated by the Company.

Improper installation may lead to water leakage, electric shock and fire.

Do not wash the air conditioner with water; otherwise, electric shock may be caused.

Use a solid standing platform.

## 2 Cleaning and Maintenance

### Cleaning of air filter screen

#### [Caution]

The air filter screen is optional.

The air filter screen can remove dust or other particles from the air. If it is blocked, the effectiveness of the air conditioner will be greatly reduced.

Therefore, please always clean the air filter screen during long-term use.

For the indoor unit in constant speed mode, if it is installed in a dusty place, the cleaning frequency of filter screen shall be increased, and once a month is recommended. For the indoor unit in constant airflow mode, the reminder for cleaning the filter screen on the wire controller shall prevail.

Replace the filter screen if the dirt is serious and difficult to clean.

Do not remove the air filter screen before cleaning, otherwise it may cause a fault.

# 1 Schematic Diagram of Steps

- ① Remove air inlet grille For the duct type air conditioner, open the air inlet grille according to the method as shown as shown in the figure.

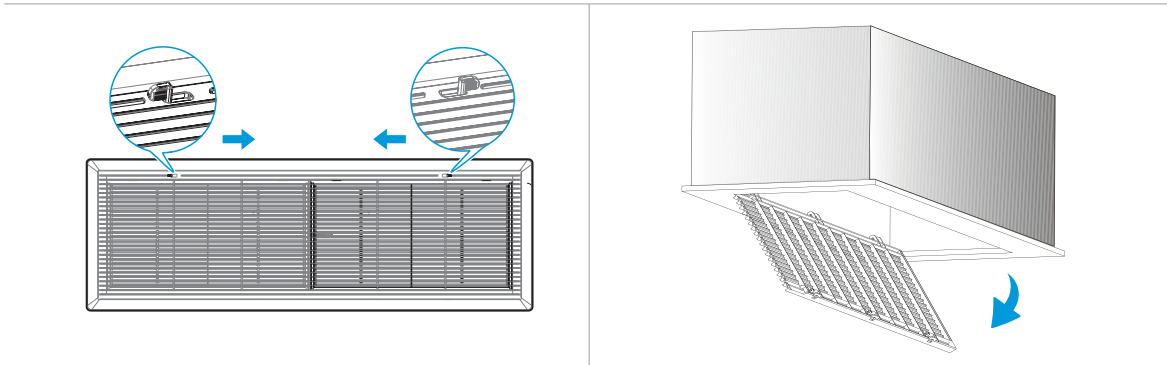

- ② Remove the filter screen.

## 💡 [Tips]

The filter screen shall be replaced, removed and installed by professional technicians. Incorrect operation may cause electric shock or injury by touching rotating parts.

- ③ Clean the filter screen.

A vacuum cleaner can be used for cleaning, and the air inlet side of the filter screen faces upward.

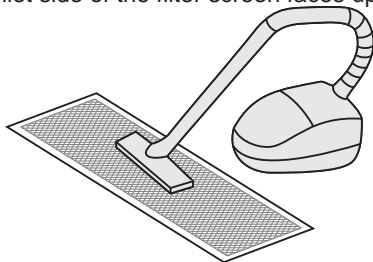

The clean water can be used for cleaning (except for the activated carbon module), and the air inlet side of the filter screen is downward.

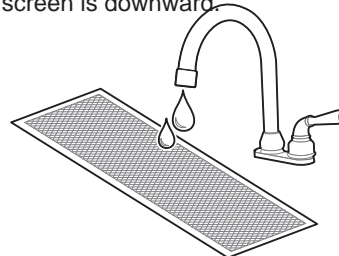

## ⚠️ [Caution]

Do not dry the filter screen with fire and other combustion appliances to avoid deformation of the filter screen.

If the filter screen is dirty, please use a soft brush and neutral detergent to clean it, then dehydrate it and dry it in the shade.

It is prohibited for non-professionals to remove, replace or repair the filter screen.

- ④ Reinstall the filter screen.

- ⑤ Reinstall and close the air inlet grille in the reverse order of steps ① and ② described above.

## Cleaning of air outlet and external panel

- ① Wipe with a soft dry cloth.
- ② If it is difficult to remove the stain, please clean it with clean water or neutral detergent.

### [Caution]

Do not use gasoline, benzene, volatile agents, detergent powder and liquid insecticide, etc.; otherwise discoloration or deformation will be caused.

Do not wet the interior of the indoor unit; otherwise, electric shock or fire accident may occur.

Do not scrub the wind deflector with water vigorously.

If the air conditioner is used without an air filter screen, dust accumulation in the air conditioner will often cause faults due to failure to remove dust in the indoor air.

## Maintenance

During in-depth maintenance, the air conditioner is generally cleaned and maintained by professional technicians every 2~3 years.

For indoor units in constant speed mode, the primary filter is generally cleaned every three months. If there is much dust in the service environment, the air filter screen will accelerate the dust accumulation, the airflow will be reduced, and the capacity will be reduced. In severe cases, too much dust will block the filter screen, affecting the air conditioning effect and the indoor sanitary environment.

Preheat in advance. When the heating season approaches, the power supply of the outdoor main unit shall be connected more than 4 hours in advance before use for preheating. The preheating time is affected by weather and temperature. In this way, the operation is more stable and it is conducive to maintaining the optimal lubrication of refrigerant oil in the A/C compressor, thus prolonging the service life of the compressor.

Before leaving the air conditioner idle for a long time, please do the following:

- ① Select "air supply" operation mode to run the indoor unit for a period of time to dry it.
- ② Power off when not in use for a long time to reduce standby power consumption. At the same time, wipe the wireless remote controller clean with a clean and soft dry cloth, and remove the battery.

### [Caution]

Before the air conditioner is idle for a long time, regularly check and clean the internal components of the outdoor unit. Please contact the local air conditioner customer service center or the special technical service department for details.

After a long idle time, check to see if the return air inlet and outlet of indoor and outdoor units are blocked or not. If they are blocked, please clean immediately.

# 3 Repair of Conventional Parts and Components

## Removal steps of water pan

When repairing the internal parts and components of the machine, it is necessary to remove the water pan first. Please remove the water pan according to the following schematic diagram, otherwise it is easy to cause water leakage of the machine (please confirm that there is no residual water in the water pan before removal).

1 Remove the top cover plate assembly

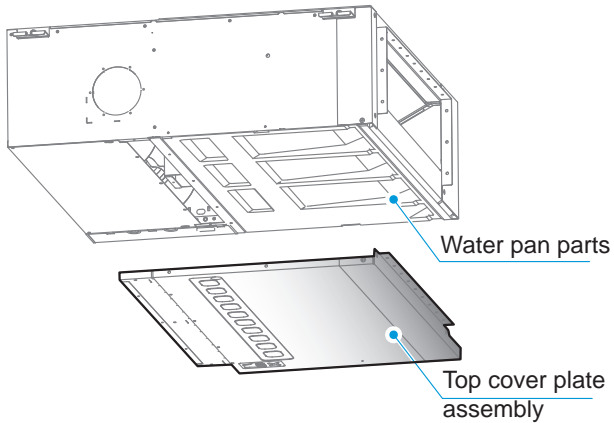

2 Take out the water pan parts downwards

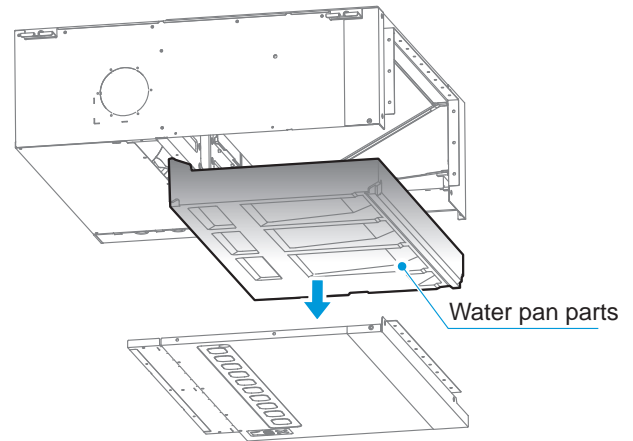

## Maintenance of volute

1 Remove the return air cover plate (Take the lower return air model as an example. Remove the filter screen first if any.)

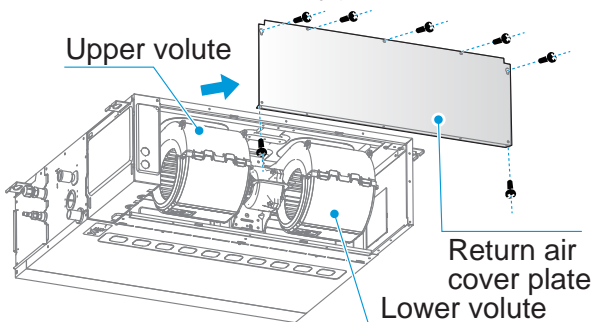

2 Remove the two screws of the top cover assembly, and rotate the part of the top cover assembly covering the volute by about 30° through long U-shaped holes as shown in the figure.

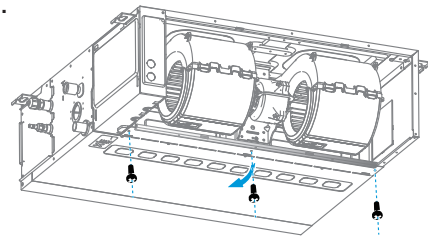

3 Take out the lower volute obliquely downwards.

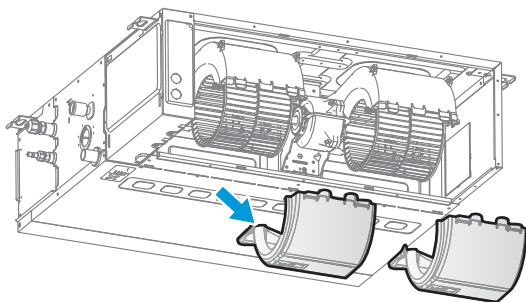

4 Loosen the screw on the upper volute.

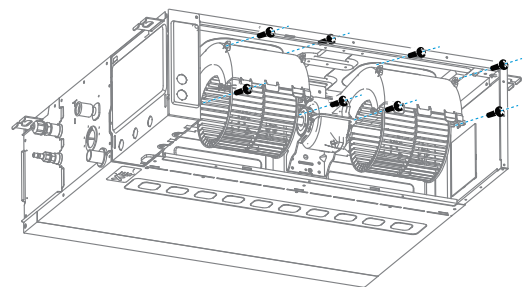

- 5 Move the upper volute backward for about 50 mm.

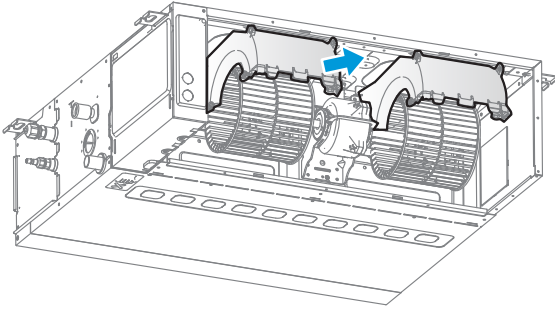

- 6 Rotate the volute downward along the rotor by more than 90°.

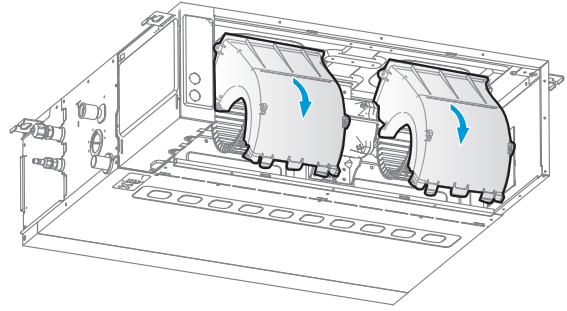

- 7 Remove the lower volute backwards.

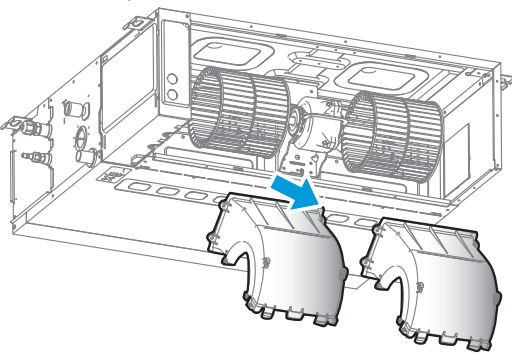

- 8 Note: For assembling, the slot shall be aligned with the clamp tongue, and the limit groove shall be aligned with the sidewall edge before fastening; then the limit groove, positioning column and buckle shall be checked for proper installation, and the limit tongue shall cover the outer side of the volute.

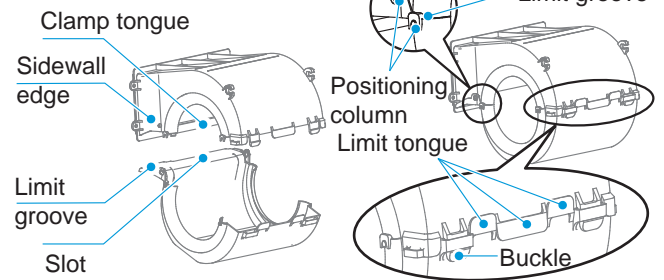

## [Tips]

In the first step of repair of the rear return air fan model, remove the return air cover plate downward, and keep other steps the same.

## Maintenance of motors, rotors

- 1 Remove the two screws from the top cover assembly.

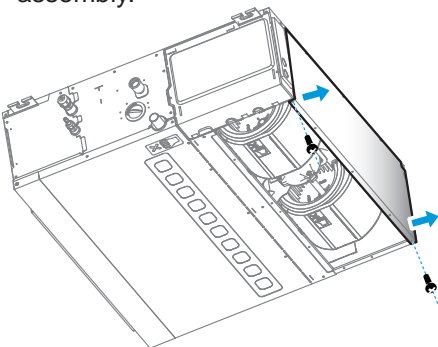

- 2 Rotate the part of the top cover assembly covering the volute by about 30° through long U-shaped holes as shown in the figure.

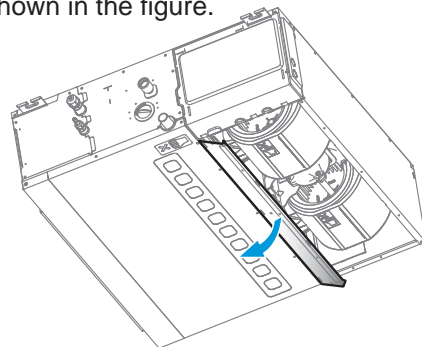

3 Press the buckle of upper volute and rotate the front edge of the lower volute about 30°.

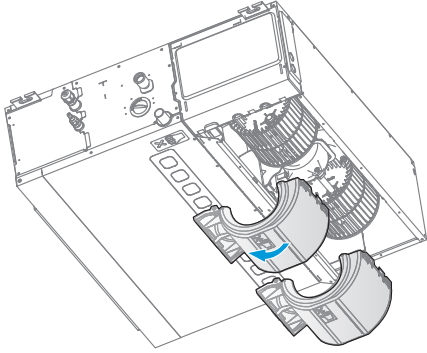

4 Loosen the fastening screws of the motor coaming and rotor.

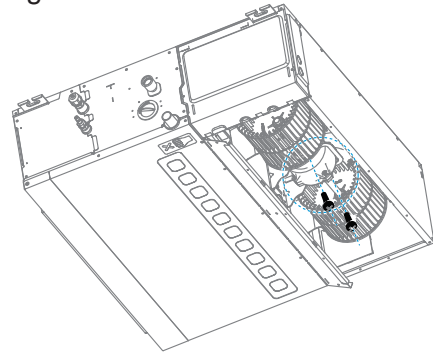

5 Remove the motor and rotor together.

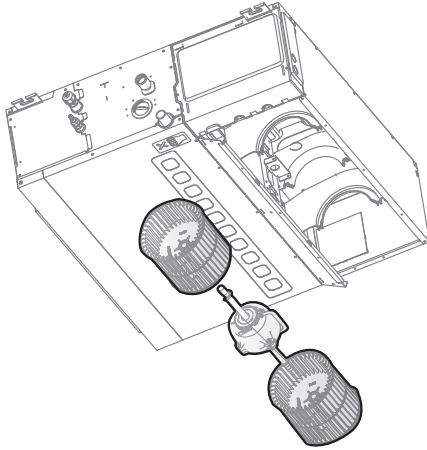

## Maintenance of drainage pump (models with a water pump), temperature sensor and electronic expansion valve

1 Remove the electric control box cover and unplug the water pump and water level switch.

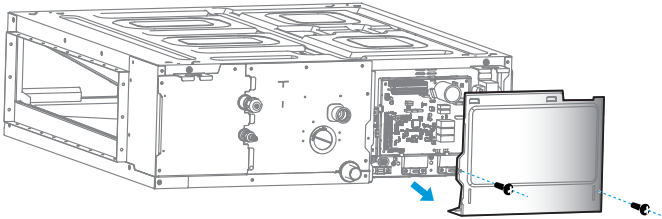

2 Remove the piping pressure plate.

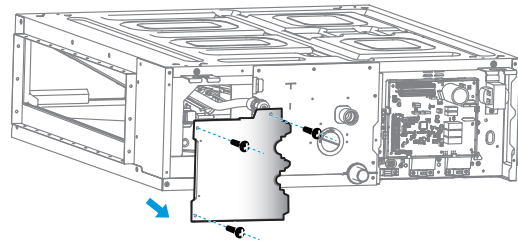

3 Remove the drainage pump assembly for repair.

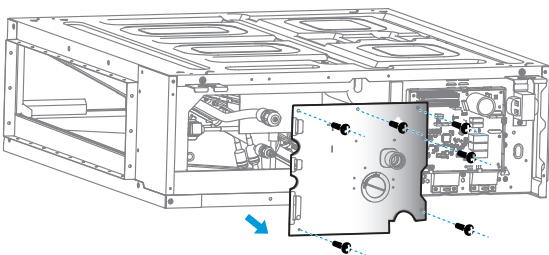

4 Replace the temperature sensor/electronic expansion valve.

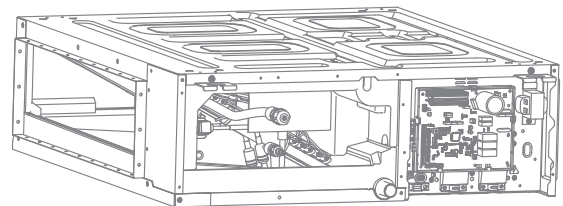

## Repair of electronic controller board

- 1 Remove the electric control box cover.
- 2 Check the circuit, components, etc., or replace the mainboard.
- 3 After replacing the mainboard, scan the QR code on the electric control box with the after-sales service tooling, and reset the machine model and capacity.

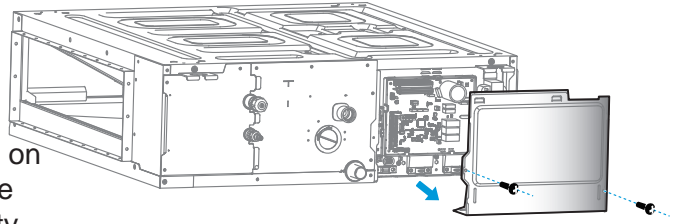

### [Tips]

It is forbidden to interchange the electronic control boards of different internal machines.

## Repair of motor shaft and coupling (three-rotor model)

- 1 Remove the two screws below the return air cover plate. Take the lower return air model as an example. Remove the filter screen first if any.

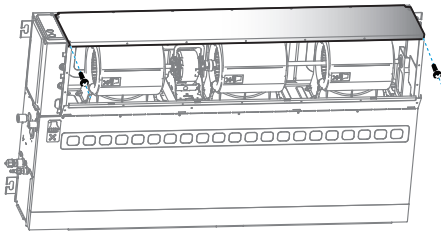

- 2 Remove the lower volute on the bearing pedestal side by referring to the repair steps of the volute. Loosen the fastening screw on the coupling.

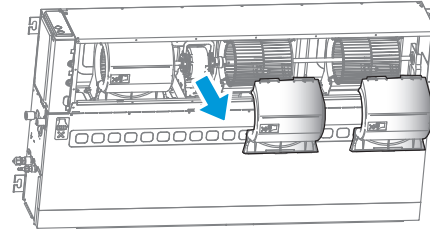

- 3 Push the coupling to the rotor side.

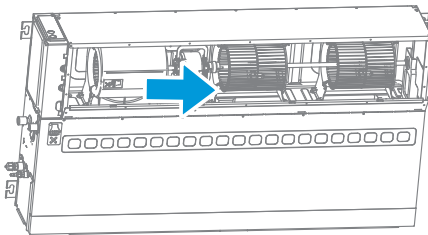

- 4 Remove the rotor, connecting shaft and coupling together.

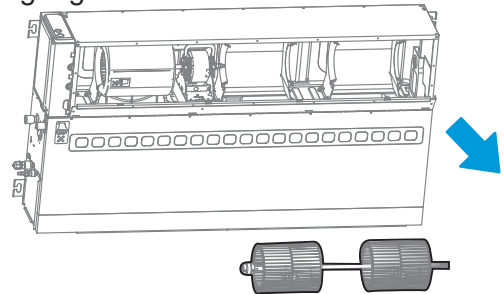

- 5 Loosen the rotor fastening screw, and remove the coupling and motor shaft.

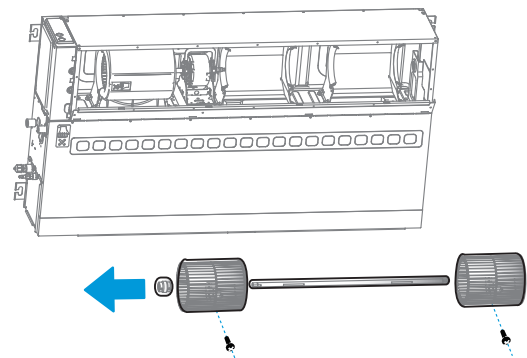

## Repair of bearing pedestal (three-rotor model)

- 1 Remove the two screws below the return air cover plate. Take the lower return air model as an example. Remove the filter screen first if any.

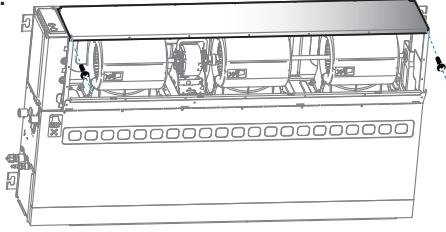

- 2 Remove the lower volute near the bearing pedestal side by referring to the repair steps of the volute.

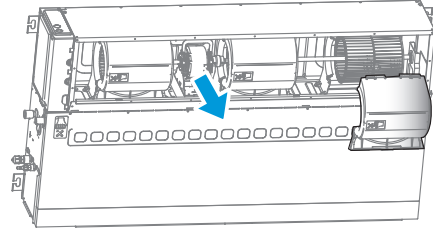

- 3 Push the bearing pedestal out to the right with a tool and remove the bearing pedestal. Or refer to the disassembly steps of motor shaft and coupling, remove the motor shaft first and then the bearing pedestal.

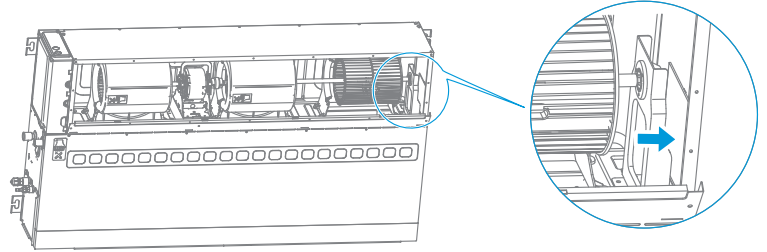







# CLIVET DECLARATION OF CONFORMITY UE

DICHIARAZIONE DI CONFORMITÀ EU  
KONFORMITÄTSEKKLÄRUNG UE  
DECLARATION DE CONFORMITE UE  
DECLARACIÓN DE CONFORMIDAD UE

## WE DECLARE UNDER OUR SOLE RESPONSIBILITY THAT THE MACHINE

DICHIARIAMO SOTTO LA NOSTRA SOLA RESPONSABILITÀ CHE LA MACCHINA  
WIR ERKLÄREN EIGENVERANTWORTLICH, DASS DIE MASCHINE  
NOUS DÉCLARONS SOUS NOTRE SEULE RESPONSABILITÉ QUE LA MACHINE  
EL FABRICANTE DECLARA BAJO SU EXCLUSIVA RESPONSABILIDAD QUE LA MÁQUINA

CATEGORY	<b>DIRECT EXPANSION TERMINALS - Heat pump</b>
CATEGORIA	<b>TERMINALI AD ESPANSIONE DIRETTA - Pompa di calore</b>
KATEGORIE	<b>DIREKTVERDAMPFUNGSGERÄTE - Wärmepumpe</b>
CATEGORIE	<b>TERMINAUX À DÉTENTE DIRECTE - Pompe à chaleur</b>
CATEGORIA	<b>TERMINALES POR EXPANSIÓN DIRECTA - Bomba de calor</b>

## TYPE / TIPO / TYP / TYPE / TIPO

MODEL	
CNT2-3-XY D15	CNT2-3-XY D22
CNT2-3-XY D28	CNT2-3-XY D36
CNT2-3-XY D45	CNT2-3-XY D56
CNT2-3-XY D71	CNT2-3-XY D80
CNT2-3-XY D90	CNT2-3-XY D112
CNT2-3-XY D125	CNT2-3-XY D140
CNT2-3-XY D160	

- **COMPLIES WITH THE FOLLOWING EC DIRECTIVES, INCLUDING THE MOST RECENT AMENDMENTS, AND THE RELEVANT NATIONAL HARMONISATION LEGISLATION CURRENTLY IN FORCE:**
- RISULTA IN CONFORMITÀ CON QUANTO PREVISTO DALLE SEGUENTI DIRETTIVE CE, COMPRESSE LE ULTIME MODIFICHE, E CON LA RELATIVA LEGISLAZIONE NAZIONALE DI RECEPIMENTO:
- DEN IN DEN FOLGENDEN EG-RICHTLINIEN VORGESEHENEN VORSCHRIFTEN, EINSCHLIEßLICH DER LETZTEN ÄNDERUNGEN, SOWIE DEN ANGEWANDTEN LANDESGESETZEN ENTSPRICHT:
- EST CONFORME AUX DIRECTIVES CE SUIVANTES, Y COMPRIS LES DERNIÈRES MODIFICATIONS, ET À LA LÉGISLATION NATIONALE D'ACCUEIL CORRESPONDANTE:
- ES CONFORME A LAS SIGUIENTES DIRECTIVAS CE, INCLUIDAS LAS ÚLTIMAS MODIFICACIONES, Y A LA RELATIVA LEGISLACIÓN NACIONAL DE RECEPCIÓN:

- 2006/42/EC** **machinery directive** / direttiva macchine  
Maschinenrichtlinie / directive sur les machines  
directiva máquinas
- 2014/30/UE** **electromagnetic compatibility** / compatibilità elettromagnetica  
Elektromagnetische Verträglichkeit / compatibilité électromagnétique  
compatibilidad electromagnética
- 2009/125/CE** **Ecodesign** /Progettazione ecocompatibile / Ecodesign / Éco-conception / Ecodiseño
- 2011/65/UE** **2015/863/UE** **RoHS**

-Unit manufactured and tested according to the followings Standards:  
-Unità costruita e collaudata in conformità alle seguenti Normative:  
-Unité construite et testée en conformité avec les Réglementations suivantes  
-Unidad construida y probada de acuerdo con las siguientes Normativas  
-Gebautes und geprüftes Gerät nach folgenden Normen

EN 60335-1 :2012/A15 :2021 EN 60335-2-40 :2003/A13 :2012  
EN 62233 :2008 EN IEC 55014-1 :2021 EN 55014-1 :2017/A11 :2020  
EN IEC 55014-2 :2021 EN 55014-2 :2015 EN IEC 61000-3-2 :2019/A1 :2021  
EN IEC 61000-3-2 :2019 EN 61000-3-3 :2013/A2 :2021  
EN IEC 61000-3-3 :2013/A1 :2019 EN IEC 61000-6-3 :2021  
EN IEC 61000-6-1 :2019  
EN 62321-1 :2013 EN 62321-2 :2014 EN 62321-3-1 :2014  
EN 62321-4 :2014 EN 62321-5 :2014 EN 62321-6 :2015  
EN 62321-7-1 :2015 EN 62321-7-2 :2017 EN 62321-8 :2017

## -Responsible to constitute the technical file is the company n°.00708410253 and registered at the Chamber of Commerce of Belluno Italy

-Responsabile a costituire il fascicolo tecnico è la società n° 00708410253 registrata presso la Camera di Commercio di Belluno Italia  
-Verantwortliche für die technischen Unterlagen zusammenstellen n°.00708410253 ist das Unternehmen bei der Handelskammer von Belluno Italien registriert  
-Responsable pour compiler le dossier technique est la société n°00708410253 enregistrée à la Chambre de Commerce de Belluno en Italie  
-Encargado de elaborar el expediente técnico es la empresa N° 00708410253 registrada en la Cámara de Comercio de Belluno Italia

FELTRE, 19/04/2023

NAME / NOME / VORNAME / PRÉNOM / NOMBRE  
SURNAME / COGNOME / ZUNAME / NOM / APELLIDOS  
COMPANY POSITION / POSIZIONE / BETRIEBSPOSITION / FONCTION / CARGO

STEFANO  
BELLÒ  
LEGALE RAPPRESENTANTE

FOR 30 YEARS WE HAVE BEEN OFFERING  
SOLUTIONS FOR SUSTAINABLE  
COMFORT AND THE WELL-BEING OF  
PEOPLE AND THE ENVIRONMENT

[www.clivet.com](http://www.clivet.com)

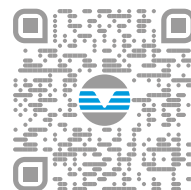

sales and service



**CLIVET SPA**  
Via Camp Lonc 25, Z.I. Villapaiera  
32032 Feltre (BL) - Italy  
Tel. +39 0439 3131 - Fax +39 0439 313300  
[info@clivet.it](mailto:info@clivet.it)

A Group Company of

