

CRH-XHE2 49.4-110.4

"Roof top" water cooled heat pump



Dear Customer,

We congratulate you on choosing this product

For many years Clivet has been offering systems that provide maximum comfort, together with high reliability, efficiency, quality and safety.

The aim of the company is to offer advanced systems, that assure the best comfort, reduce energy consumption and the installation and maintenance cost for the life cycle of the system.

The purpose of this manual is to provide you with information that is useful from reception of the equipment, through installation, operational usage and finally disposal so that this advanced system offers the best solution.

Yours faithfully,

CLIVET Spa

The data contained in this manual is not binding and may be changed by the manufacturer without prior notice.

Reproduction, even in part, is FORBIDDEN © Copyright - CLIVET S.p.A. - Feltre (BL) - Italia

Index of contents

| | | |
|----|------------------------|----|
| 1 | General description | 4 |
| 2 | Reception | 6 |
| 3 | Positioning | 8 |
| 4 | Water connections | 10 |
| 5 | Aeraulic connections | 12 |
| 6 | Electrical connections | 13 |
| 7 | Start-up | 19 |
| 8 | Control | 26 |
| 9 | Maintenance | 49 |
| 10 | Accessories | 53 |
| 11 | Decommissioning | 60 |
| 12 | Residual risks | 61 |
| 13 | Technical information | 62 |
| 14 | Dimensional drawings | 65 |

1 General description

1.1 Manual

The manual provides correct unit installation, use and maintenance.

Pay particular attention to:



Warning, identifies particularly important operations or information.



Prohibited operations that must not be carried out, that compromise the operating of the unit or may cause damage to persons or things.

- It is advisable to read it carefully so you will save time during operations.
- Follow the written indications so you will not cause damages to things and injuries people.

1.2 Preliminaries

Only qualified personnel can operate on the unit, as required by the regulation in force.

1.3 Risk situations



The unit has been designed and created to prevent injuries to people.

During designing it is not possible to plane and operate on all risk situation.

Read carefully "Residual risk" section where all situation which may cause damages to things and injuries to people are reported.

Installation, starting, maintenance and repair required specific knowledge; if they are carried out by inexperienced personnel, they may cause damages to things and injuries people.

1.4 Intended use

Use the unit only:

- civil air-conditioning
- keep to the limits foreseen in the technical schedule and in this manual

The manufacturer accepts no responsibility if the equipment is used for any purpose other than the intended use.

1.5 Installation

Outdoor installation



The positioning, hydraulic system, refrigerating, electrics and the ducting of the air must be determined by the system designer in accordance with local regulations in force.

Follow local safety regulations.

Verify that the electrical line characteristics are in compliance with data quotes on the unit serial number label.

1.6 Maintenance

Plan periodic inspection and maintenance in order to avoid or reduce repairing costs.



Turn the unit off before any operation.

1.7 Modification



All unit modifications will end the warranty coverage and the manufacturer responsibility.

1.8 Breakdown/Malfuction

Disable the unit immediately in case of breakdown or malfunction.

Contact a certified service agent.

Use original spares parts only.

Using the unit in case of breakdown or malfunction:

- voids the warranty
- it may compromise the safety of the unit
- may increase time and repair costs

1.9 User training



The installer has to train the user on:

- Start-up/shutdown
- Set points change
- Standby mode
- Maintenance
- What to do / what not to do in case of breakdown

1.10 Data update

Continual product improvements may imply manual data changes.

Visit manufacturer web site for updated data.

1.11 Indications for the User



Keep this manual with the wiring diagram in an accessible place for the operator.

Note the unit data label so you can provide them to the assistance centre in case of intervention (see "Unit identification" section).

Provide a unit notebook that allows any interventions carried out on the unit to be noted and tracked making it easier to suitably note the various interventions and aids the search for any breakdowns.

In case of breakdown or malfunction:

- Immediately deactivate the unit
- Contact a service centre authorized by the manufacturer



The installer must train the user, particularly on:

- Start-up/shutdown
- Set points change
- Standby mode
- Maintenance
- What to do / what not to do in case of breakdown

1.12 Unit identification

The serial number label is positioned on the unit and allows to identify all the unit features.



The matriculation plate must never be removed.

The matriculation plate shows the indications foreseen by the standards, in particular:

- unit type
- serial number (12 characters)
- year of manufacture
- wiring diagram number
- electrical data
- manufacturer logo and address

1.13 Serial number

It identifies uniquely each unit.

Must be quoted when ordering spare parts.

1.14 Assistance request

Note data from the serial number label and write them in the chart on side, so you will find them easily when needed.

| |
|---------------------------|
| Series |
| Size |
| Serial number |
| Year of manufacture |
| Electrical wiring diagram |

2 Reception



You have to check before accepting the delivery:

- That the unit hasn't been damaged during transport
- That the materials delivered correspond with that indicated on the transport document comparing the data with the identification label positioned on the packaging.

In case of damage or anomaly:

- Write down on the transport document the damage you found and quote this sentence: "Conditional acceptance clear evidence of deficiencies/damages during transport"
- Contact by fax and registered mail with advice of receipt to supplier and the carrier.



Any disputes must be made within 8 days from the date of the delivery. Complaints after this period are invalid.

2.1 Storage

Observe external packaging instructions.

2.2 Handling

1. Verify unit weight and handling equipment lifting capacity.
2. Identify critical points during handling (disconnected routes, flights, steps, doors).
3. Suitably protect the unit to prevent damage.
4. lifting brackets
5. Lifting with balance
6. Lifting with spacer bar
7. Align the barycenter to the lifting point
8. Use all the lifting brackets (see the dimensional section)
9. Gradually bring the lifting belts under tension, making sure they are positioned correctly.
10. Before starting the handling, make sure that the unit is stable.

1



2

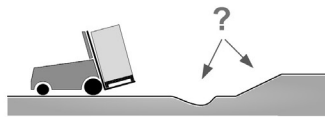

3

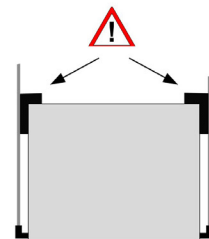

4

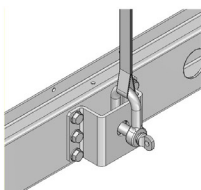

5

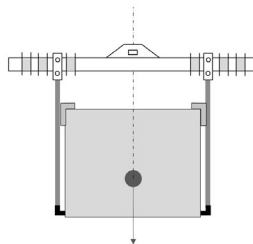

6

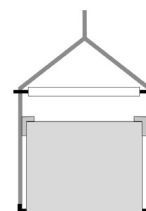

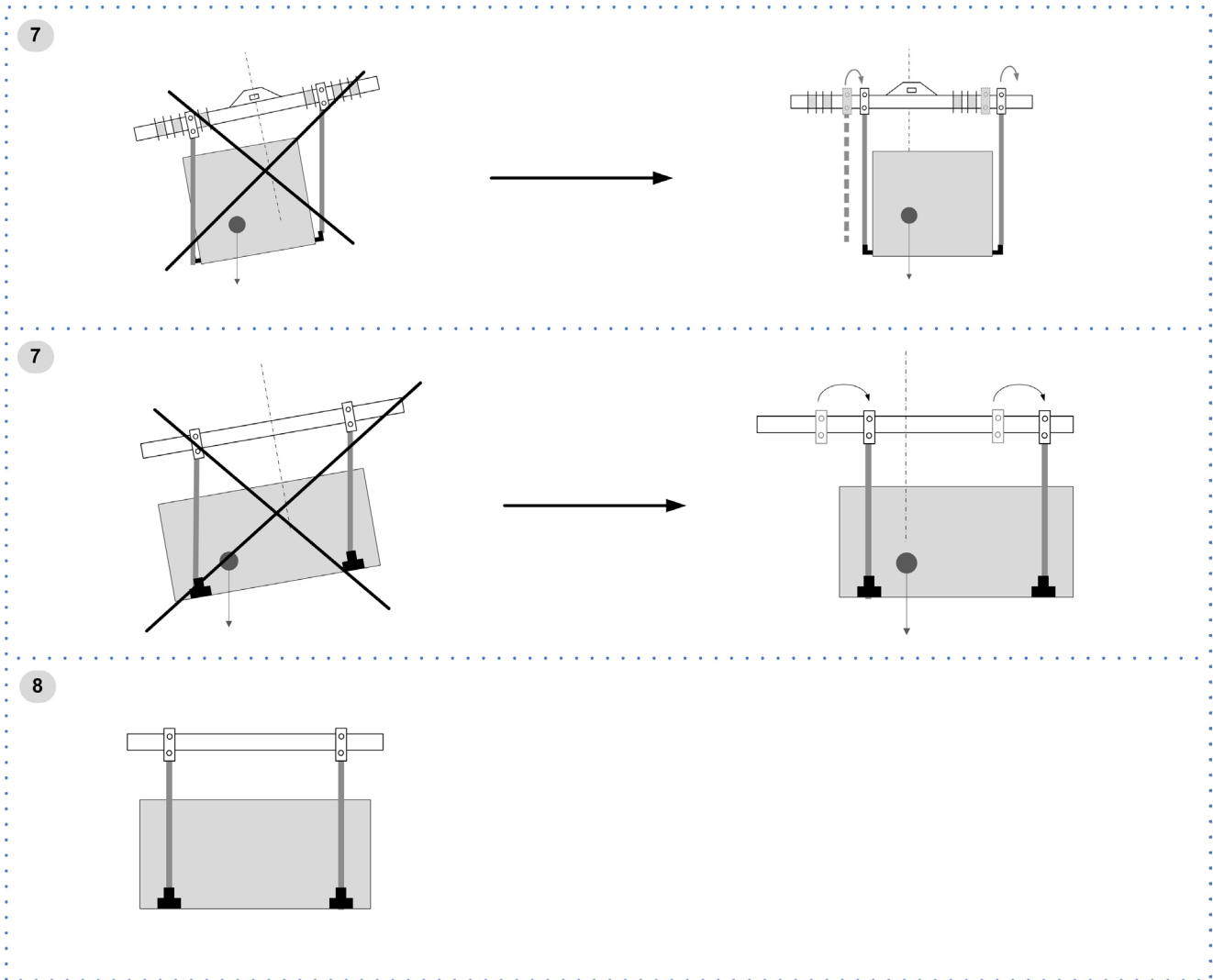

2.3 Packaging removing

Be careful not to damage the unit.

Cut-off valves installed at inlet and outlet (both on the water technique circuit as well as that of the hot domestic water) allow maintenance operations without having to empty the system.

Recycle and dispose of the packaging material in conformity with local regulations.

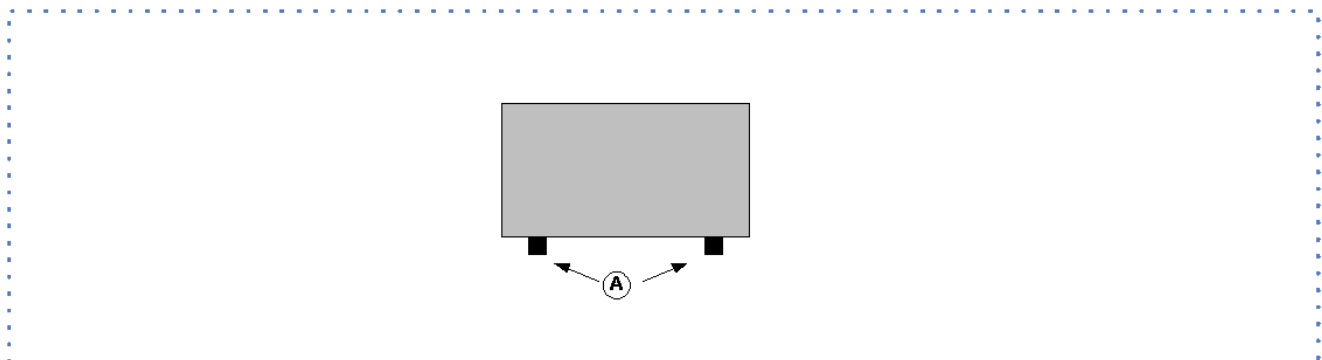

A Supports for handling: remove after the handling.

3 Positioning

During positioning consider these elements:

- Technical spaces requested by the unit
- Electrical connections
- Water connections
- Spaces for air exhaust and intake

3.1 Functional spaces

Functional spaces are designed to:

- guarantee good unit operation
- carry out maintenance operations
- protect authorized operators and exposed people

Respect all functional spaces indicated in the DIMENSIONS section.

Double all functional spaces if two or more unit are aligned.

3.2 Positioning



Units are designed to be installed:

- EXTERNAL
- in fixed positions

Limit vibration transmission:

- use anti-vibration devices or neoprene strips on the unit support points
- install flexible joints on the hydraulic connections
- install flexible joints on the hydraulic connections

Choose the installation place according to the following criteria:

- Customer approval
- safe accessible position
- technical spaces requested by the unit
- spaces for the air intake/exhaust
- max. distance allowed by the electrical connections
- install the unit raised from the ground
- verify unit weight and bearing point capacity
- verify that all bearing points are aligned and leveled
- condensate water draining
- consider the maximum possible snow level
- Avoid installations in places subject to flooding

Protect the unit with suitable fence in order to avoid access to unauthorised personnel (children, vandals, etc.)

A correct circulation of the air is mandatory to guarantee the good unit operating.



Avoid therefore:

- obstacles to the airflow
- difficulty of exchange
- leaves or other foreign bodies that can obstruct the ext. dampers
- heat or pollution sources close to the unit (chimneys, extractors etc..)
- stratification (cold air that stagnates at the bottom)
- recirculation (expelled air that is sucked in again)
- incorrect positioning, close to very high walls, attics or in angles that could give rise to stratification or recirculation phenomenons



Avoid the accumulation of snow and ice in front of the exhaust air outlet

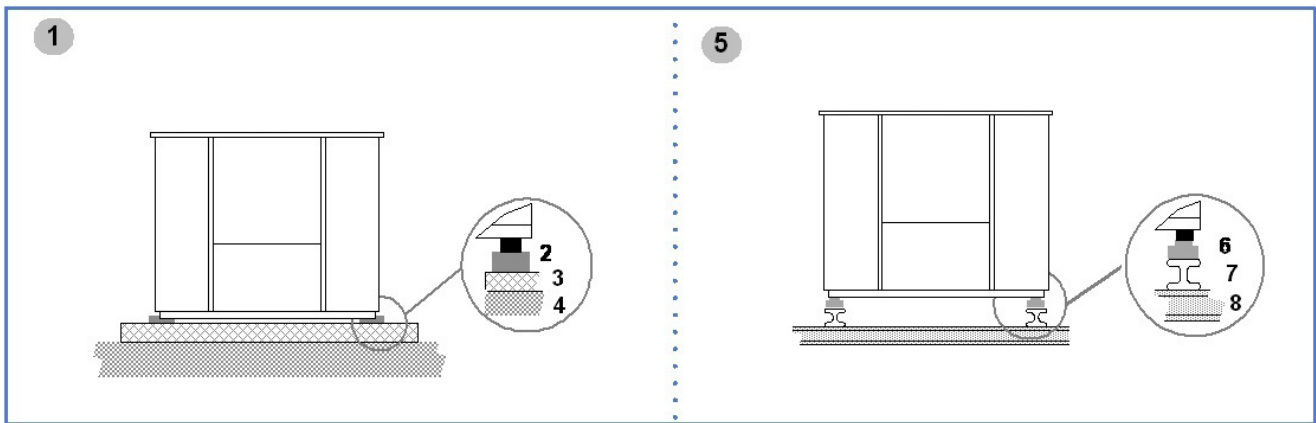

- 1 Positioning on concrete floor
- 2 2 cm thick neoprene strips
- 3 concrete floor
- 4 insulation

- 5 Positioning on steel structure
- 6 antivibration mounts
- 7 steel structure
- 8 steel structure

3.3 Safety valve gas side

The installer is responsible for evaluating the opportunity of installing drain tubes, in conformity with the local regulations in force (EN 378).

3.4 Electronic filter

For details see:
10 Accessories p. 54

4 Water connections

4.1 Water quality

Water features

- confirming to local regulations
- total hardness < 14°fr
- within the limits indicated by table

The water quality must be checked by qualified personnel.

Water with inadequate characteristics can cause:

- pressure drop increase
- reduces energy efficiency
- increased corrosion potential

Acceptable water quality values:

| | | |
|--|-----------|-----|
| PH | 7,5 ÷ 9,0 | |
| SO ₄ ²⁻ | < 100 | ppm |
| HCO ₃ ⁻ /SO ₄ ²⁻ | > 1 | |
| Total Hardness | 4,5 ÷ 8,5 | dH |
| Cl ⁻ | < 50 | ppm |
| PO ₄ ³⁻ | < 2,0 | ppm |
| NH ₃ | < 0,5 | ppm |

| | | |
|------------------------------|--------|-----|
| Free Chlorine | < 0,5 | ppm |
| Fe ₃ ⁺ | < 0,5 | ppm |
| Mn ⁺⁺ | < 0,05 | ppm |
| CO ₂ | < 50 | ppm |
| H ₂ S | < 50 | ppb |
| Temperature | < 65 | °C |
| Oxygen content | < 0,1 | ppm |

Provide a water treatment system if values fall outside the limits.



The warranty does not cover damages caused by limestone formations, deposits and impurities from the water supply and / or failure from failed system clearing to clean system.

4.2 Risk of freezing

If the unit or the relative water connections are subject to temperatures close to 0°C:

- mix water with glycol, or
- safeguard the pipes with heating cables placed under the insulation, or
- empty the system in cases of long non-use

4.3 Anti-freeze solution

The use of an anti-freeze solution results in an increase in pressure drop.



Make sure that the glycol type utilized is inhibited (not corrosive) and compatible with the water circuit components.



Do not use different glycol mixture (i.e. ethylene with propylene).

4.4 Water flow-rate

The project water-flow must be:

- inside the exchanger operating limits (see the TECHNICAL INFORMATION section)
- guarantee, also with variable system conditions (for example in systems where some circuits are bypassed in particular situations).

4.5 Water filter



It must be installed immediately in the water input of the unit, in a position that is easily accessible for cleaning.



The filter never should be removed, this operation invalidates the guaranty.

4.6 Condensate drain

The condensate must be disposed in order to avoid damages to people and things.

- Unit discharge fitting: the connection must not transmit mechanical stresses and must be performed taking care not to damage the unit discharge fitting.
- Provide a siphon that, eliminating the negative pressure caused by the fan, prevents the air intake from the discharge duct.
- The ducting must have a min. slope of 3% to allow the runoff.
- Anchor the ducting with an adequate number of supports.
- Insulate the duct and the siphon to avoid the condensate drippings.
- Connect the condensate discharge to a sewerage drainage network.

⊘ DO NOT use white water or drainage networks to avoid the aspiration of odours in the case of evaporation of water contained in the siphon.

⚠ Check at the end of the work, the regular condensate runoff pouring some water in the tray.

4.7 Operation sequence

Close all vent valves in the high points of the unit hydraulic circuit

Close all drain valves in the low points of the unit hydraulic circuit:

- Heat exchangers
 - Pumps
 - collectors
1. Carefully wash the system with clean water: fill and drain the system several times.
 2. Apply additives to prevent corrosion, fouling, formation of mud and algae.
 3. Fill the plant
 4. Execute leakage test.
 5. Isolate the pipes to avoid heat dispersions and formation of condensate.
 6. Leave various point of service free (wells, vent-holes etc).

⚠ Neglecting the washing will lead to several filter cleaning interventions and at worst cases can cause damages to the exchangers and the other parts.

4.8 Humidifier

For details see:

10 Accessories p. 54

4.9 Hydraulic connections

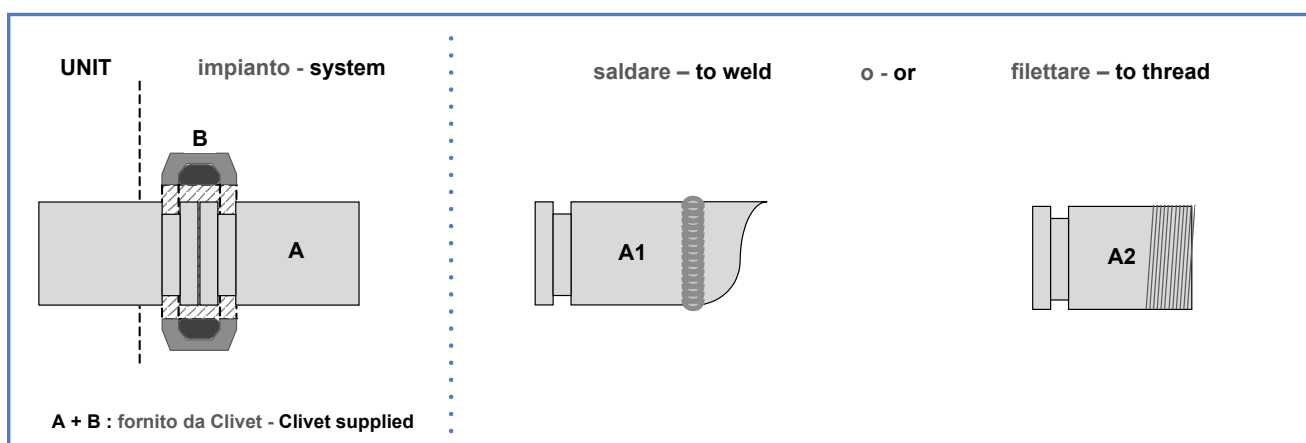

⊘ Retirer le joint de connexion avant de souder le tuyau de l'installation.

⚠ The rubber gasket might be irreparably damaged.

5 Aeraulic connections

The dimensioning and correct execution of the aeraulic connections are fundamental to guarantee good unit operation and adequate level of silence in the room.

When designing and manufacturing the ducting, consider LOAD LOSSES, AIR FLOW AND SPEED that must be consistent with the unit features.



Particularly consider that load losses higher than the unit useful prevalence, lead to reduction in flow rate, with consequent unit blocks.

- the weight of the channels must not burden on the connection flanges
- place anti-vibration joints between channels and unit
- connection to the flanges and between the various sections of the channels must guarantee air seal, avoiding dispersions penalising the overall efficiency of the system
- limit the load losses by optimising the path, the type and number of bends and junctions
- use wide bends evaluating the opportunity of equipping them with deflectors (in particular with high air speed or bends with reduced radius)

5.1 Treated air channelling

The internal surface of the channel must be smooth, enable its washing and must not contaminate the air.

Thermally isolate the channels and the flanges to avoid energy losses and forming of condensation.

DIFFUSERS INLETS GRILLES

A correct diffusion of the air in the room is determining for the level of comfort.



When choosing and positioning the grilles, inlets and diffusers, avoid:

- excessive air speed
- forming of stagnant and stratification areas
- cold air delivery in room
- forming of localised currents (also due to uneven distribution of air)
- excessive room temperature variations, vertically and horizontally
- short circuits of the supply air towards the return air



For sound comfort, consider that:

- the air diffusers must be chosen verifying the sound power generated at nominal flow rate conditions
- the cut-off to diffusers must be carried out with flexible elements
- the return grilles must be widely dimensioned

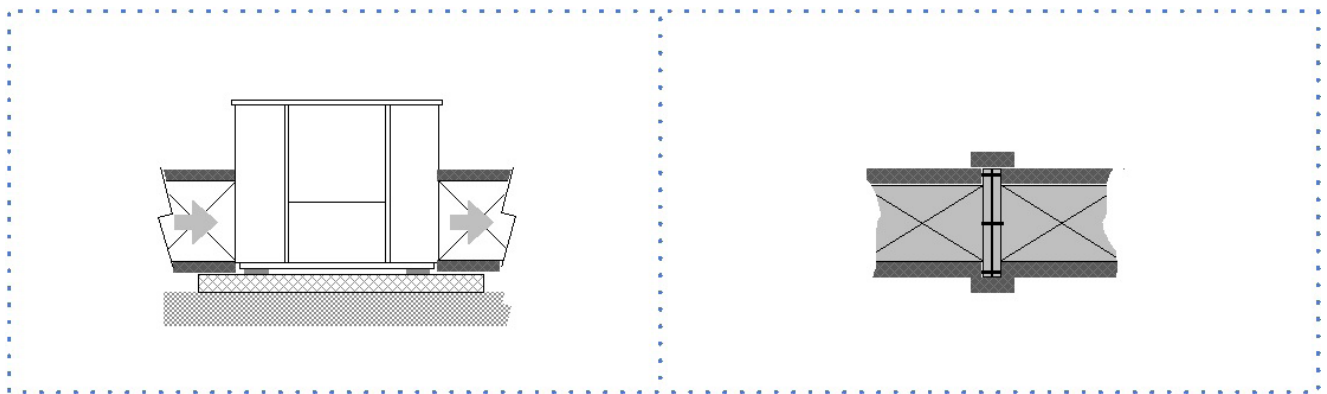

Thermally isolate the channels and the flanges to avoid energy losses and forming of condensation.

6 Electrical connections

The characteristics of the electrical lines must be determined by qualified electrical personnel able to design electrical installations; moreover, the lines must be in conformity with regulations in force.

The protection devices of the unit power line must be able to stop all short circuit current, the value must be determined in accordance with system features.

The power cables and the protection cable section must be defined in accordance with the characteristics of the protections adopted.

All electrical operations should be performed by trained personnel having the necessary qualifications required by the regulations in force and being informed about the risks relevant to these activities.

Operate in compliance with safety regulations in force.

6.1 Electrical data



The serial number label reports the unit specific electrical data, included any electrical accessories.

The electrical data indicated in the technical bulletin and in the manual refer to the standard unit, accessories excluded.

The matriculation plate shows the indications foreseen by the standards, in particular:

- Voltage
- F.L.A.: full load ampere, absorbed current at maximum admitted conditions
- F.L.I.: full load input, full load power input at max. admissible condition
- Electrical wiring diagram Nr.

6.2 Connections

1. Refer to the unit electrical diagram (the number of the diagram is shown on the serial number label).
2. Verify that the electrical supply has characteristics conforming to the data shown on the serial number label.
3. Before starting work, ensure the unit is isolated, unable to be turned on and a safety sign used.
4. Ensure correct earth connection.
5. Ensure cables are suitably protected.
6. Before powering up the unit, make sure that all the protections that were removed during the electrical connection work have been restored.

6.3 Signals / data lines

Do not exceed the maximum power allowed, which varies, according to the type of signal.

Lay the cables far from power cables or cables having a different tension and that are able to emit electromagnetic disturbances.

Do not lay the cable near devices which can generate electromagnetic interferences.

Do not lay the cables parallel to other cables, cable crossings are possible, only if laid at 90°.

Connect the screen to the ground, only if there aren't disturbances.

Guarantee the continuity of the screen during the entire extension of the cable.

Respect impedance, capacity and attenuation indications.

6.4 Power input

Fix the cables: if vacated may be subject to tearing.



The cable must not touch the compressor and the refrigerant piping (they reach high temperatures).

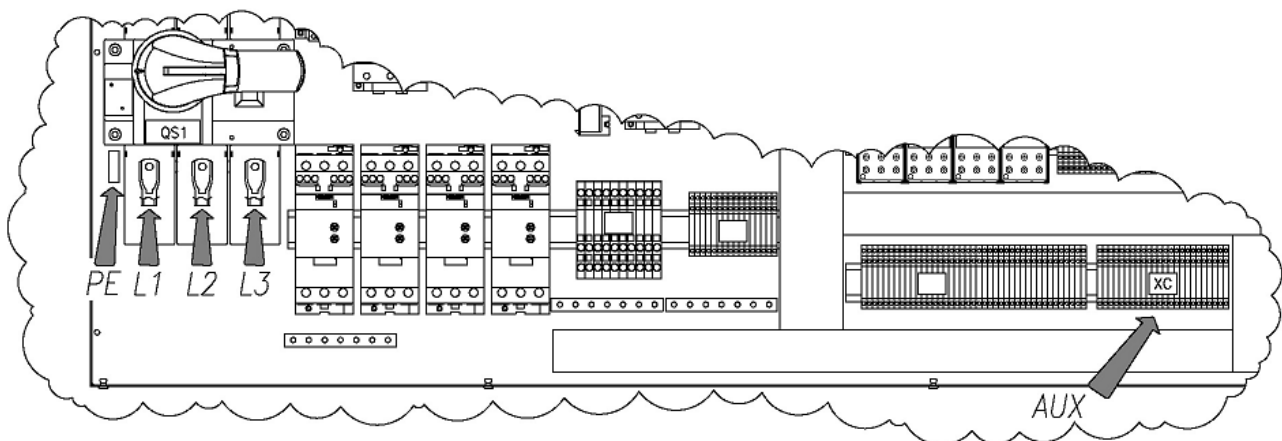

6.5 Connections performer by customer

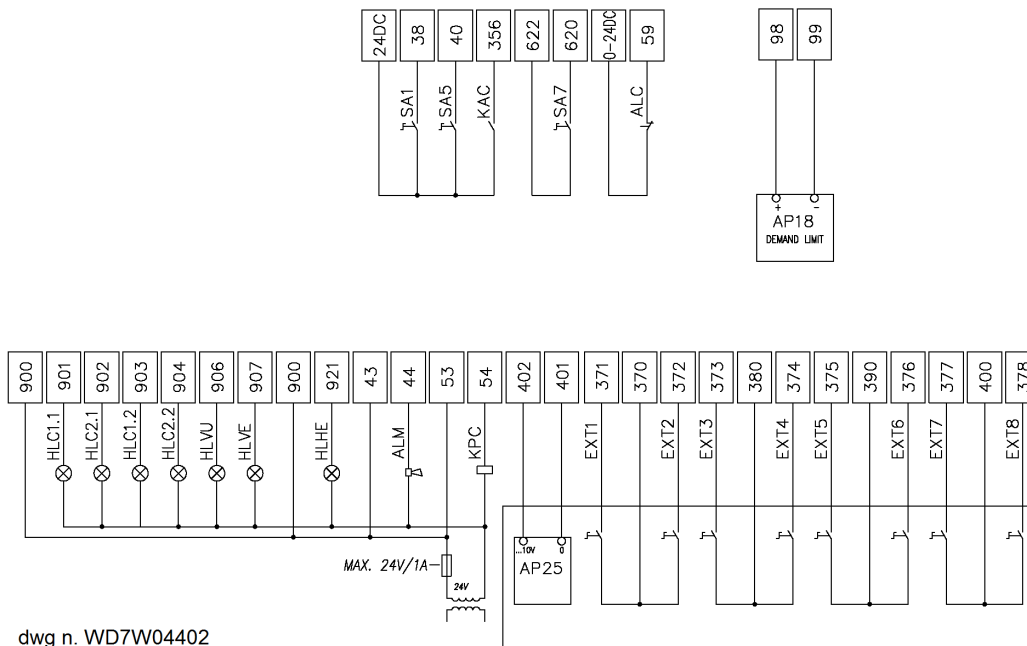

dwg n. WD7W04402

| | |
|----------------------|---|
| ALC | contatto pulito da impianto di segnalazione allarme antincendio free contact from signalling system of fire alarm contact libre de installation de signalisation alarme d'incendie Schließerkontakt aus der Signalisierungsanlage der Feuerschutzalarm contacto libre de instalación de señalización alarma antincendio |
| HLVU | lampada segnalazione stato ventilatore di mandata indicating light of the supply fan status lampe de signalisation de l'état ventilateur de refoulement Signallampe des Zustandes des Druckventilators lámpara indicadora estado ventilador de impulsión |
| ALM | segnalazione blocco cumulativo cumulative fault signal signalisation alarmé Sammelstörmeldung señalización bloqueo cumulativo |
| AP18 | demand-limit demand-limit demand-limit demand-limit |
| SA1 | selettore on/off remoto remote on/off selector sélecteur ON/OFF déporté Fernwahrschalter Ein/Aus selector on/off remoto |
| HLC1.1.. ..HLC2.2 | lampada segnalazione stato compressore compressor status signal lamp lampe de signalisation état compresseur Signallampe Verdichtierzustand lámpara de señalización estado compresor |
| SA5 | ingresso configurabile settable input entrée configurable konfigurierbares Eingabe entrada configurable |

| | |
|-------------------|---|
| HLHE | lampada di segnalazione stato funzionamento pompa di calore warning light of the heat pump operating status lampe de signalisation état fonctionnement pompe à chaleur Anzeigelampe Betriebszustand der Wärmepumpe lámpara indicadora estado funcionamiento bomba de calor |
| AP25 | Modulo estrazione modulante con segnale 0-10V Modulating extraction module with 0-10V signal Module d'extraction modulante avec signal 0-10V Modulierender Ayllassmodul mit 0-10V Signal Módulo extracción moduliadora con señal 0-10V |
| EXT1.. ...EXT8 | contatto pulito estrattore ambiente ambient extractor potential-free contact contact libre extracteur ambiant potentialfreier Kontakt des Raumabzug contacto libre extractor ambiente |
| SA7 | selettore abilitazione allo scarico manuale umidificatore enabling selector to the humidifier manual discharge sélecteur validation à la décharge manuelle humidificateur Freigabewähler auf den manuellen Ablauf des Befuchters selector habilitación a la descarga manual humidificador |
| HLF | lampada segnalazione nessun allarme in corso sensore fumo indicating light of no alarm in progress smoke sensor lampe de signalisation aucune alarme en cours capteur fumée Signallampe keinen Alarm im Laufe Rauchsensor lámpara indicadora ninguna alarma en curso sensor humo |
| HLE | lampada segnalazione stato ventilatore di ripresa e/o espulsione indicating light of the return and/or supply fan status lampe de signalisation état ventilateur d'aspiration et/ou refoulement Signallampe des Saug und/oder Ablauventilatorstatus lámpara indicadora estado ventilador d'aspiración y/o impulsión |
| KPC | comando pompa/circolatore della batteria integrativa pump/circulating pump control of the integration coil commande pompe/pompe de circulation de la batterie supplémentaire Pumpe/Zirkulationspumpe-Steuerung der Zusatzbatterie mando bomba/bomba de circulación de la batería complementaria |
| KAC | modulo controllo remotizzato "on/off" serranda aria esterna "on/off" remote control module of the fresh air damper module contrôle à distance "on/off" du rideau air neuf ernsteuermodul "on/off" der Außenluftklappe módulo de control a distancia "on/off" de la compuerta aire exterior |

6.6 SA5 input

Settable input

P0056 ModeFanClean

| | | |
|---------|---------------------|-------------------------|
| 0 None | not used | not used |
| 1 Mode | 0 = cool, 1 = heat | change HEAT - COOL mode |
| 2 Fan | 0 = no cmd, 1 = fan | fan only |
| 3 Clean | 0 = off, 1 = on | clean |

6.7 Computer connection

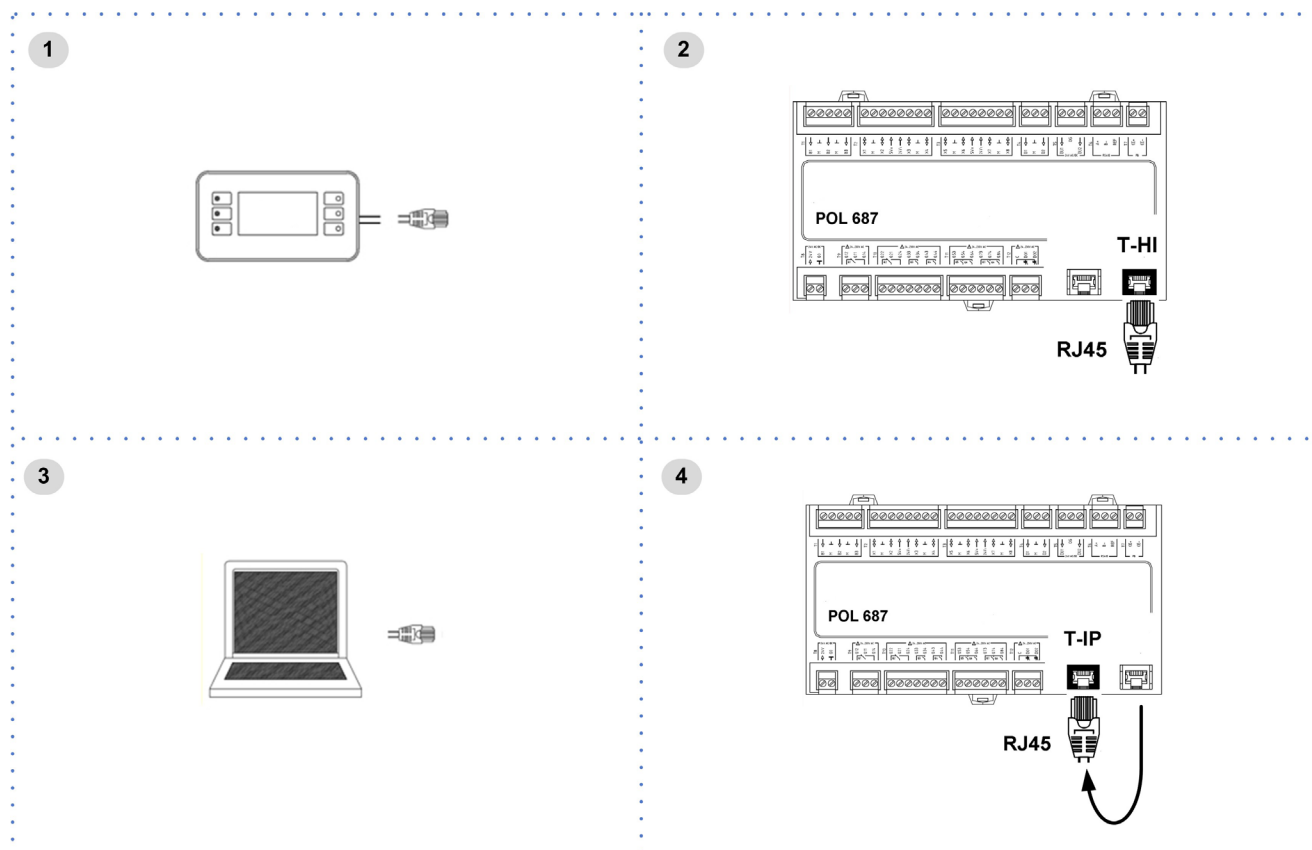

1. Service keypad
2. RJ45: standard connection
3. P.C.-not supplied
4. P.C. connection, shift RJ45 from T-HI to T-IP

Configure P.C.

1. connect P.C. and main module with LAN cable
2. check in the taskbar that the connection is active
3. open Control Panel and select Network and sharing center
4. select Modify board setting
5. select Local area connection (LAN)
6. select Internet protocol version 4 (TCP) IPV4 and enter Property
7. set the IP address 192.168.1.100
8. set Subnet mask as 255.255.255.0
9. confirm (OK)
10. enter Start (Windows button)
11. write the command cmd and enter/do it
12. write and run the command Ping 192.168.1.42
13. the message, connection is OK, will appear when successful
14. enter the browser (Chrome, Firefox ecc)
15. write and run the command http://192.168.1.42
16. Userid = WEB
17. Password = SBTAdmin!

6.8 Remote control

Option

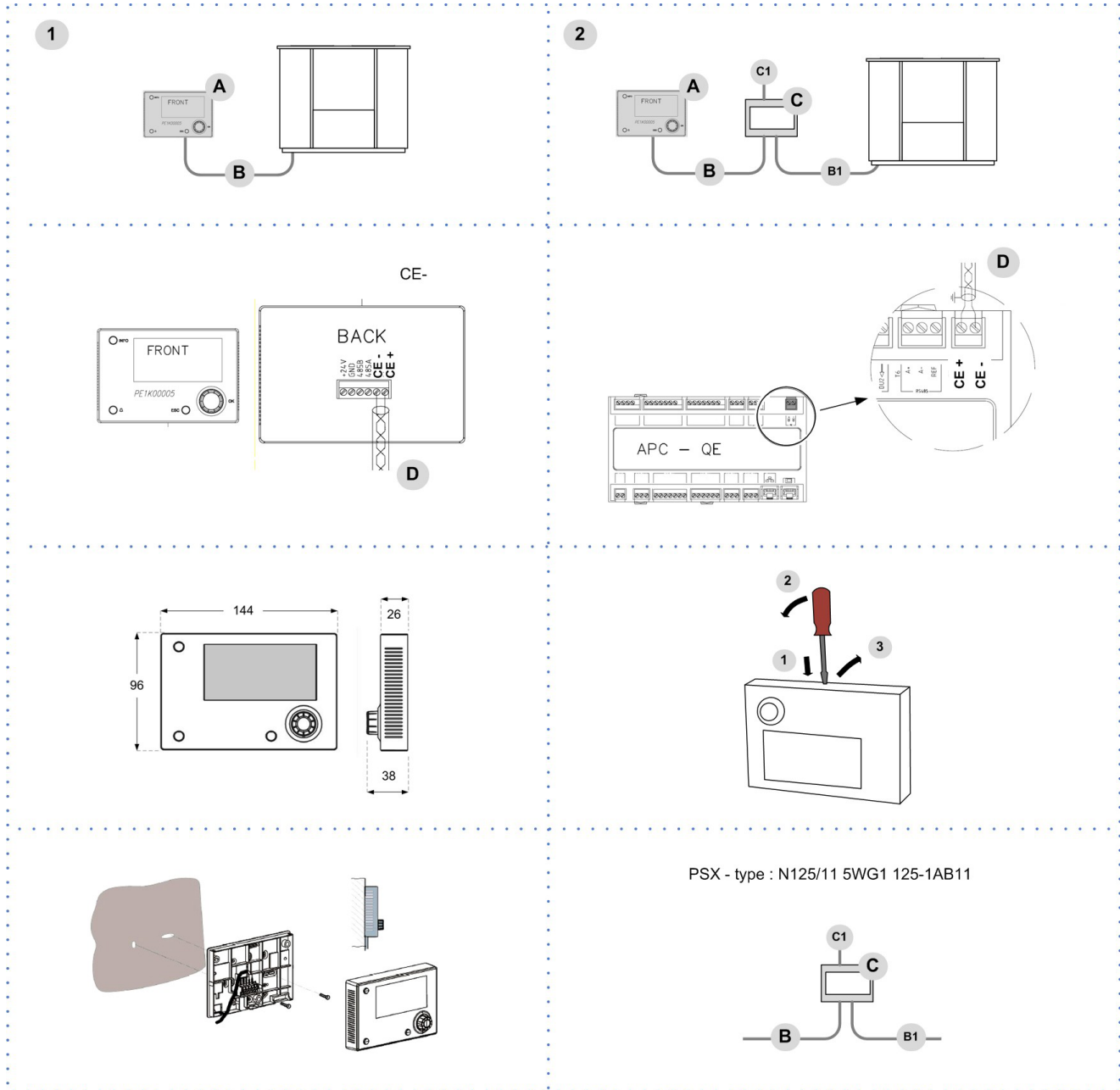

- 1 Distance up to 350 mt
- 2 Distance up to 700 mt

- A User interface
- B = B1 KNX bus, max 350 mt
twisted pair with shield, \varnothing 0,8 mm
EIB/KNX cable marking recommende
- C PSX - Mains power supply unit
pwer supply unit N125/11 5WG1 125-1AB11
- C1 AC 120...230V, 50...60Hz
- D KNX bus, max 350 mt

6.9 Modbus - RS485

Option

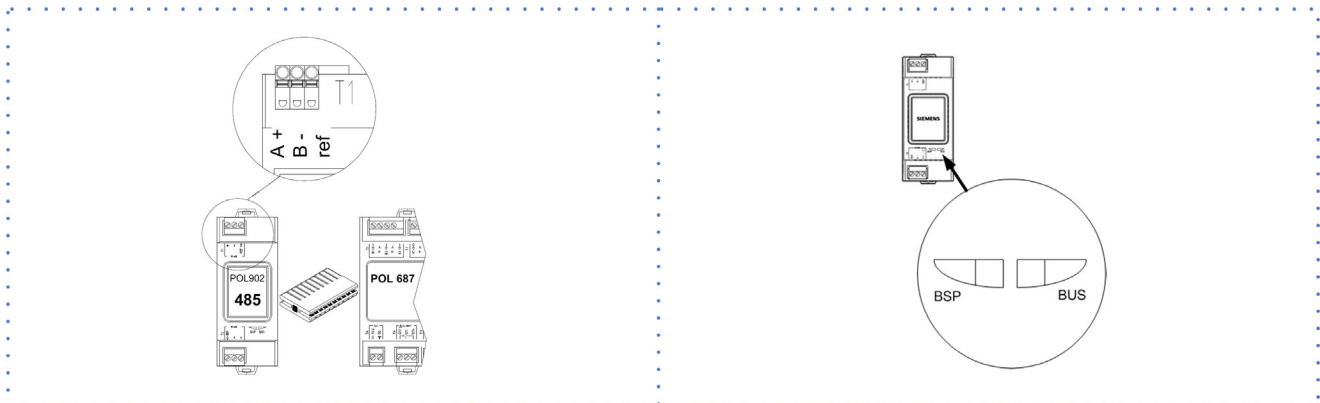

LED BSP
green communication with AP1 module
yellow communication ok
red flashing: software error
fixed: hardware error

LED BUS
green communication ok
yellow startup / channel not communicating
red communication down

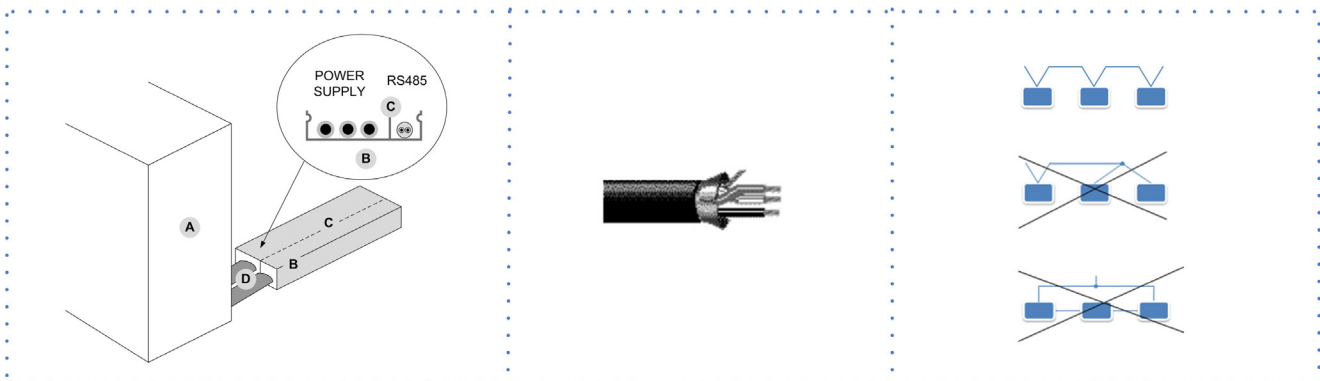

- Unit
- Metal conduit
- Metal septums
- Metal-lined sheath (sleeve)

Modbus / LonWorks / Cable requirements

Couple of conductors twisted and shielded

Section of conductor 0,22mm²...0,35mm²

Rated power between conductors $\leq 50 \text{ pF/m}$

Nominal impedance 120 Ω

Recommended cable BELDEN 3106A

- Every RS485 serial line must be set up using the 'In/Out' bus system.
- Other types of networks are not allowed, such as Star or Ring networks.
- The difference in potential between the earth of the two RS485 devices that the cable shielding needs to be connected to must be lower than 7 V
- There must be suitable arresters to protect the serial lines from the effects of atmospheric discharges
- A 120 ohm resistance must be located on the end of the serial line. Alternatively, when the last serial board is equipped with an internal terminator, it must be enabled using the specific jumper, dip switch or link.
- The cable must have insulation features and non-flame propagation in accordance with applicable regulations.
- The RS485 serial line must be kept as far away as possible from sources of electromagnetic interference.

6.10 LonWorks

Option

LonWorks

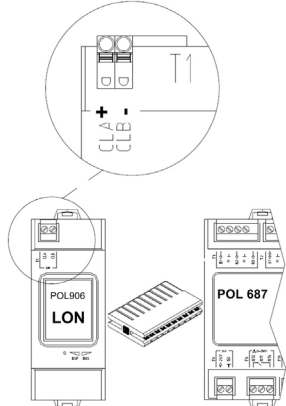

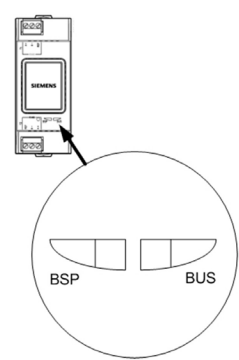

LONWORK CABLE TYPE
Echelon allows three cable types for channel type TP/FT-10, including the Category 5 network cable used commonly in building automation and control (TIA 568A Cat-5).

CAT-5 SPECIFICATIONS
Unshielded cable, twisted pair with at least 18 beats per meter:

- Cross-sectional area Min. \varnothing 0.5mm, AWG24, 0.22mm²
- Impedance 100 +/- 15% @ f > 1 MHz
- Operating capacity between two wires of a pair < 46 nF/km
- Capacity pair to ground, asymmetric. < 3.3 nF/km
- DC loop resistance < 168 Ω

| | |
|--|--|
| <p>LED BSP</p> <p>green</p> <p>yellow</p> <p>red</p> | <p>communication with AP1 module</p> <p>communication ok</p> <p>software ok but communication with AP1 down</p> <p>flashing: software error</p> <p>fixed: hardware error</p> |
|--|--|

| | |
|--|--|
| <p>LED BUS</p> <p>green</p> <p>yellow</p> <p>red</p> | <p>communication with LonWorks</p> <p>ready for communication</p> <p>startup</p> <p>flashing: communicating not possible</p> <p>communication down</p> |
|--|--|

6.11 BACnet IP

Option

BACnet

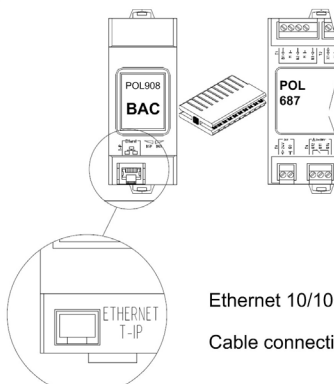

Ethernet 10/100 Mbit (IEEE 802.3U)
Cable connection RJ45 jack, 8 pins

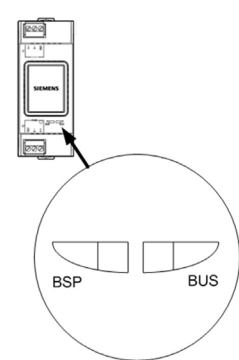

| | |
|--|--|
| <p>LED BSP</p> <p>green</p> <p>yellow</p> <p>red</p> | <p>communication with AP1 module</p> <p>communication ok</p> <p>software ok but communication with AP1 down</p> <p>flashing: software error</p> <p>fixed: hardware error</p> |
|--|--|

| | |
|--|---|
| <p>LED BUS</p> <p>green</p> <p>yellow</p> <p>red</p> | <p>communication with BACnet</p> <p>ready for communication</p> <p>startup</p> <p>BACnet server down</p> <p>restart after 3 sec</p> |
|--|---|

7 Start-up

7.1 General description

The indicated operations should be done by qualified technician with specific training on the product.

Upon request, the service centres performing the start-up.

The electrical, water connections and the other system works are by the installer.

Agree upon in advance the start-up data with the service centre.

Before checking, please verify the following:

- the unit should be installed properly and in conformity with this manual
- the electrical power supply line should be isolated at the beginning
- the unit isolator is open, locked and equipped with the suitable warning
- make sure no tension is present



After turning off the power, wait at least 5 minutes before accessing to the electrical panel or any other electrical component.



Before accessing check with a multimeter that there are no residual stresses.

7.2 Preliminary checks

For details refer to the different manual sections.

Unit OFF power supply

1. safety access
2. functional spaces
3. structure integrity
4. fans run freely
5. unit on vibration isolators
6. air filters present and clean
7. completed aeraulic system
8. unit input water filter + shut-off valves for cleaning
9. vibration isolators on water connections
10. minimum system water content
11. cleaned system
12. loaded system + possible glycol solution + corrosion inhibitor
13. system under pressure
14. vented system
15. refrigerant circuit visual check
16. earthing connection
17. power supply features
18. electrical connections provided by the customer

7.3 Start-up sequence

For details refer to the different manual sections.

Unit ON power supply

1. compressor crankcase heaters operating at least since 8 hours
2. off-load voltage measure
3. phase sequence check
4. shut-off valve refrigerant circuit open
5. load voltage measure and absorptions
6. liquid sight glass check (no bubbles)
7. check all fan operating
8. air flow rate measurement
9. supply, return and outdoor air temperature measurement
10. water source temperature measurement
11. measure super-heating and sub-cooling
12. check no anomalous vibrations are present
13. climatic curve personalization
14. climatic curve personalization
15. scheduling personalization
16. fire alarm configuration *
17. complete and available unit documentation

7.4 Refrigeration circuit

1. Check carefully the refrigerating circuit: the presence of oil stains can mean leakage caused by transportation, movements or other).
2. Verify that the refrigerating circuit is in pressure: Using the unit manometers, if present, or service manometers.
3. Make sure that all the service outlets are closed with proper caps; if caps are not present a leak of refrigerant can be possible.
4. Open the valves of the refrigerant circuit, if there are any.

7.5 Water circuit

1. Before realizing the unit connection make sure that the hydraulic system has been cleaned up and the cleaning water has been drained.
2. Check that the water circuit has been filled and pressurized.
3. Check that the shut-off valves in the circuit are in the "OPEN" position.
4. Check that there isn't air in the circuit, if required, evacuate it using the air bleed valve placed in the system high points.
5. When using antifreeze solutions, make sure the glycol percentage is suitable for the type of use envisaged.



Neglecting the washing will lead to several filter cleaning interventions and at worst cases can cause damages to the exchangers and the other parts.

| Weight of glycol (%) | 10 | 20 | 30 | 40 |
|---------------------------|------|------|-------|-------|
| Freezing temperature (°C) | -3.9 | -8.9 | -15.6 | -23.4 |
| Safety temperature (°C) | +1 | -4 | -10 | -19 |

7.6 Electric Circuit



Verify that the unit is connected to the ground plant.

Check the conductors are tightened as: the vibrations caused by handling and transport might cause these to come loose.

Connect the unit by closing the sectioning device, but leave it on OFF.

Check the voltage and line frequency values which must be within the limits: 400/3/50 +/- 10%

Check and adjust the phase balance as necessary: it must be lower than 2%

Example

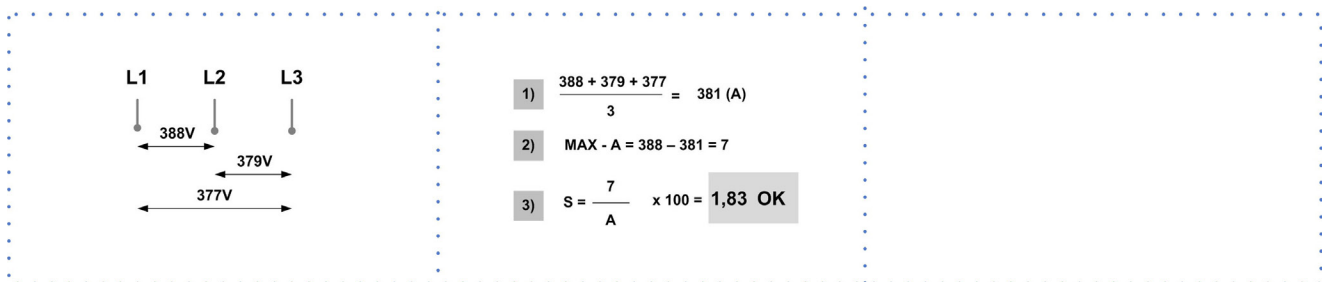

Working outside of these limits can cause irreversible damages and voids the warranty.

7.7 Compressor crankcase heaters

Connect the oil resistances on the compressor crankcase at least 8 hours before the compressor is to be started:

- at the first unit start-up
 - after each prolonged period of inactivity
1. Connect the heaters: sectioning device on 1 / ON
 2. To make sure that heaters are working, check the power input.
 3. At start-up the compressor crank-case temperature on the lower side must be higher at least of 10°C than the outside temperature.



Do not start the compressor with the crankcase oil below operating temperature.

7.8 Voltages

Check that the air and water temperatures are within in the operating limits.

Start-up the unit.

With unit operating in stable conditions, check:

- Voltage
- Total absorption of the unit
- Absorption of the single electric loads

7.9 Scroll compressor

The Scroll compressors have only one rotation direction.

In the event it is reversed, the compressor is not immediately damaged, but increases its noise.
 After a few minutes, the compressor blocks due to intervention of the thermal protection.
 In this case, disconnect power supply and invert 2 phases on the machine power supply.
 Avoid the compressor working for a long time with contrary rotation: more than 2-3 of these anomalous start-ups can damage it.
 To ensure the rotation direction is correct, measure the condensation and suction pressure.
 The pressures must significantly differ: upon start-up, the suction pressure decreases whereas the condensation one, increases.

7.10 Remote controls

Check that the remote controls (ON-OFF etc) are connected and, if necessary, enabled with the respective parameters as indicated in the "electrical connections" section.

Check that probes and optional components are connected and enabled with the respective parameters ("electrical connections" section and following pages).

7.11 Air flow setting

The real unit flow is according to the aeraulic system features.

⚠ Before checking, make sure that the system has been completed in all its parts (shunts, dampers, grilles, diffusers etc.).

⚠ Check the doors and windows of the serviced room are closed.

⚠ Calibration must be carried out with unit all in recirculation.

The unit is in full recirculation during the first 20 minutes from start-up.

Set the flow rate:

P0274 SfFanSpeedOut

7.12 Air flow management

Standard mode

The air flow supply remains constant in all heat load conditions and operation modes.

ECO mode

The air flow supply remains constant at varied heat loads and is shutdown when setpoint is fulfilled.

Variable airflow

Option

The air flow supply varies depending on the heat load, up to a minimum value compatible with the distribution system and the chosen air diffusion.

The ventilation remains active even when the setpoint is fulfilled.

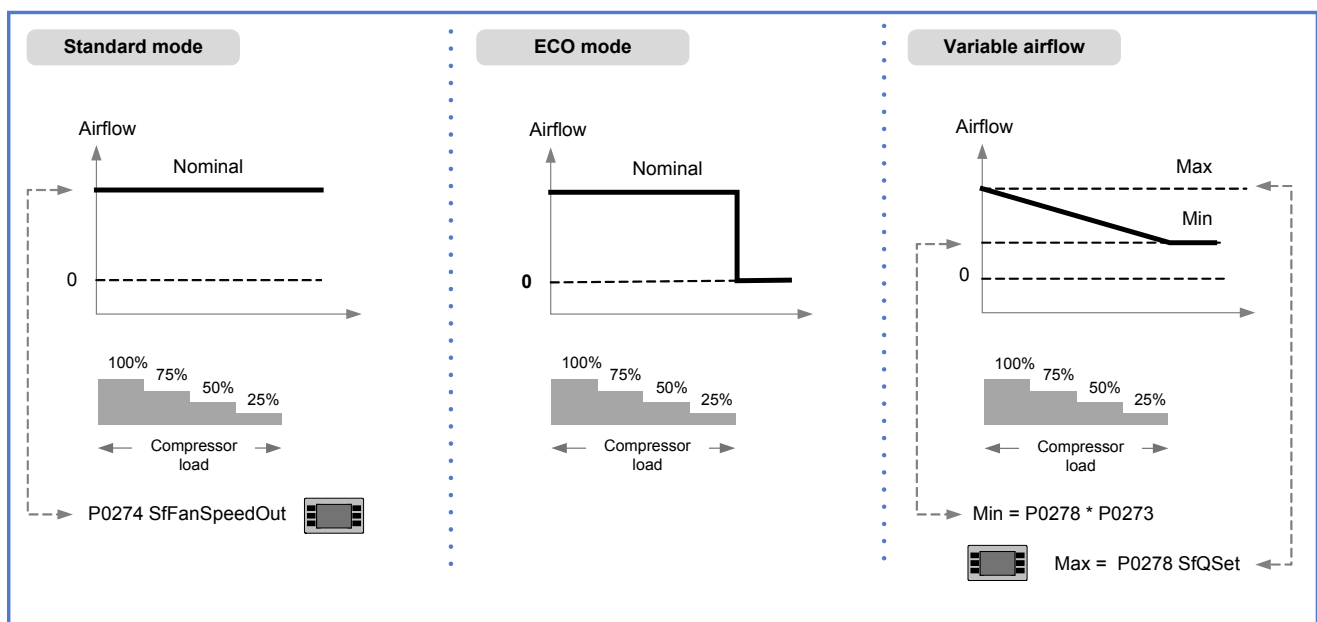

7.13 ECO mode

The air flow supply remains constant at varied heat loads and is shutdown when setpoint is fulfilled.

To further increase the energy savings in this condition, it is also possible to set less demanding operation setpoints for the unit in respect to the standard mode.

This function is indicated for the thermal maintenance of the served area in case it is temporarily not used, which can for example occur at night.

The ECO mode can be activated:

- On/Off button
- Automatically by means supervision system

Example in cooling mode:

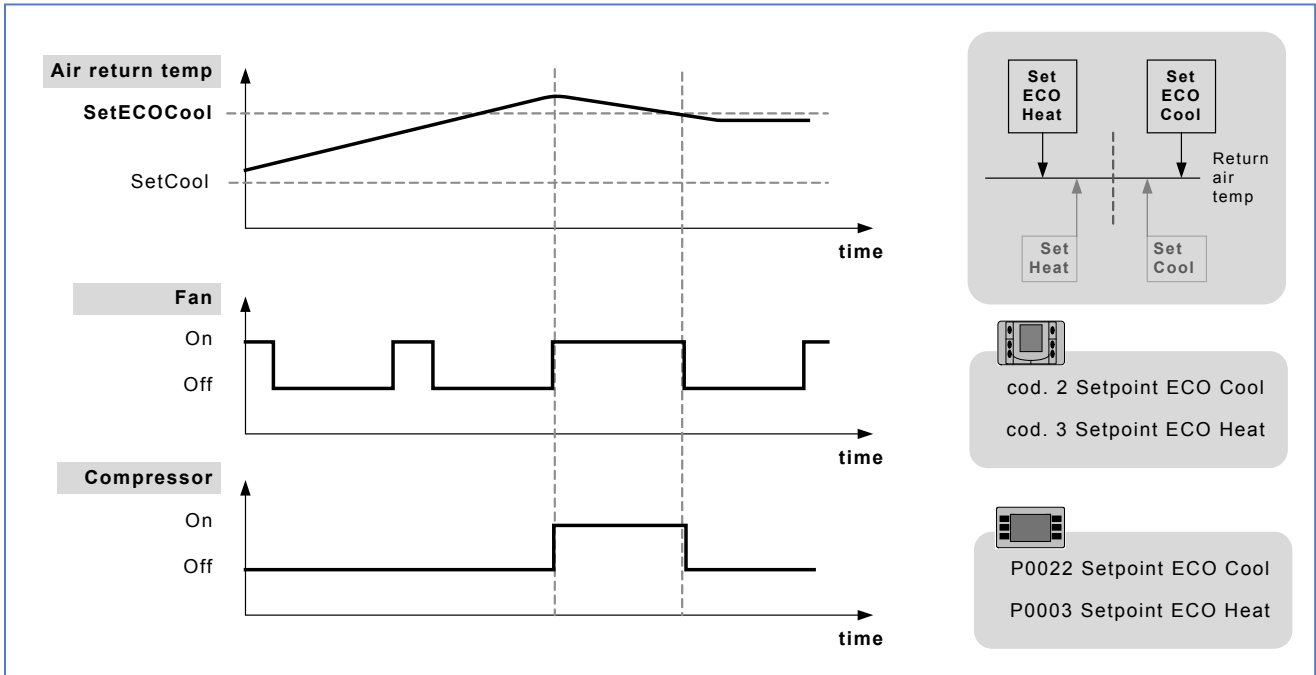

7.14 Set-point automatic compensation

The set changes automatically according to the outside temperature.

Even the operating mode changes automatically according to the outside temperature.

The variation is defined by the climatic curve.

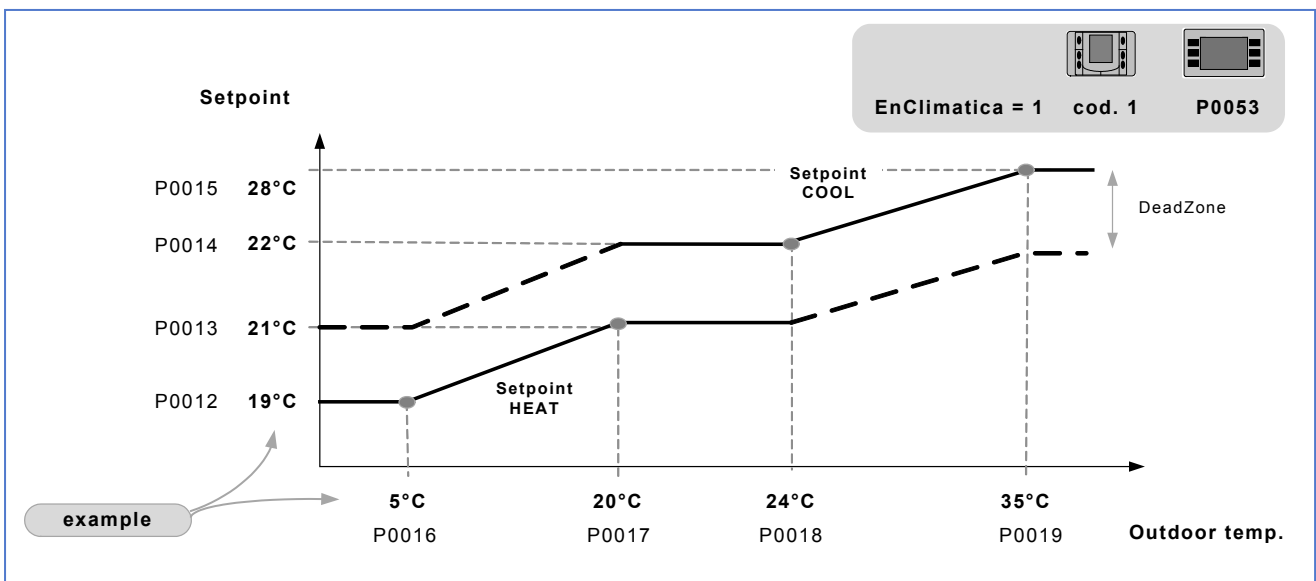

7.15 Ambient pressure control

The ambient pressure control device compares the return pressure with the external pressure and compensates any variations by acting on the outdoor air damper.

This way, the unit maintains the relevant ambient pressure desired by the user, who can choose between the overpressure, depression or equal-pressure.

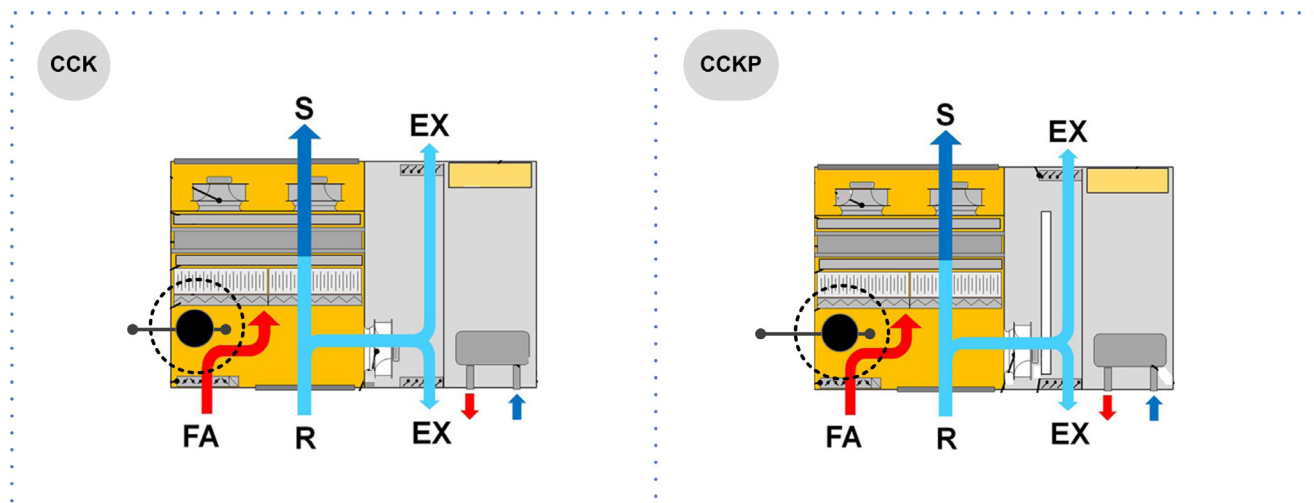

Room pressure calibration

1. check the doors and windows of the serviced room are closed
2. calibration must be carried out with unit all in recirculation
3. show on the display the status: PDiffEsterna differential pressure outdoor-return
4. wait for the pressure value to stabilise and take note of the value
5. to maintain the room in neutral pressure, memorise the detected value in P0334 SetPAmb
6. to maintain the room in overpressure, memorise a higher value respect to that detected
7. to maintain the room in depression, memorise a lower value

7.16 Constant supply airflow

Option

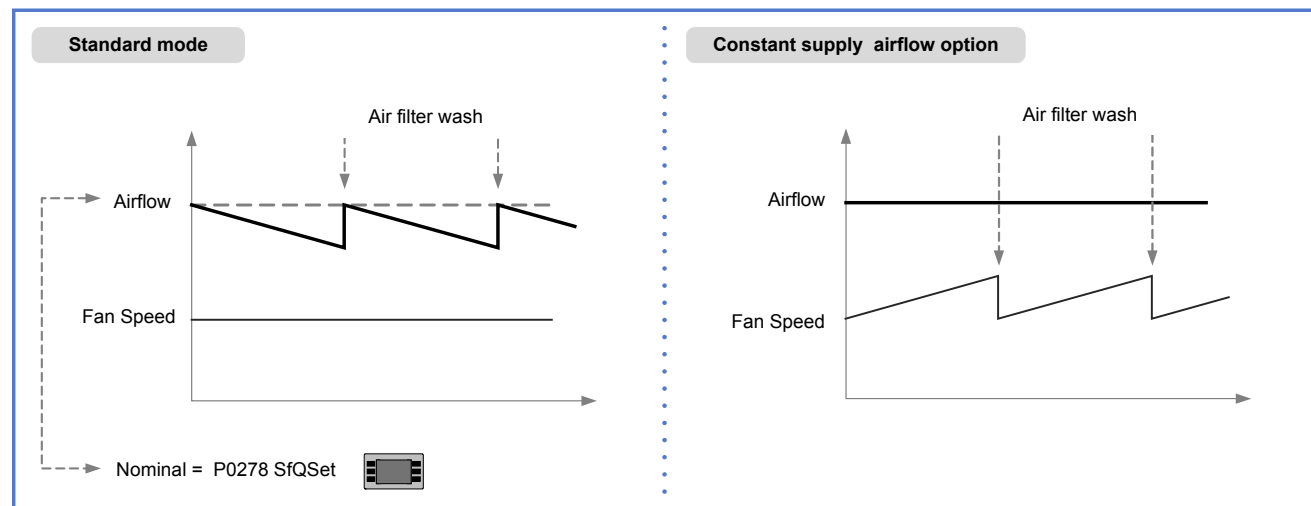

The real unit flow is according to the aeraulic system features.

- ⚠ Before checking, make sure that the system has been completed in all its parts (shunts, dampers, grilles, diffusers etc.).
- ⚠ Check the doors and windows of the serviced room are closed.
- ⚠ Calibration must be carried out with unit all in recirculation.
The unit is in full recirculation during the first 20 minutes from start-up.
Set the flow rate:
P0278 SfQSet (l/s)

7.17 Fire alarm: configuration

The unit is able to manage the signal coming from a fire detection system or fire control unit installed built-in, activating one of the logics illustrated, which can be set by parameter.

P0094 TypeFireMode

In the presence of alarm signal, the compressors are Always switched off; moreover, the remote on-off is disabled together with the switch on/off control from keypad.



The unit cannot be used as smoke extractor.



Any fire detection devices built-in the unit must be considered as an auxiliary safety system, and, accordingly, must not be a replacement for any fire detection devices in the room.

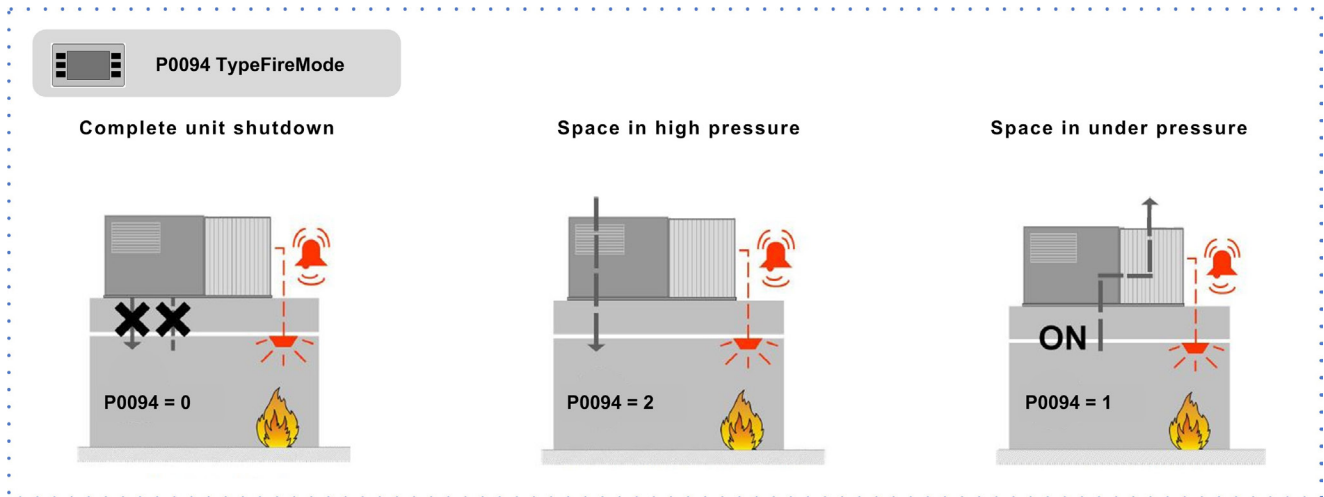

7.18 Textile channels

Option

The operation allows to set the start-up ramp of the supply fan

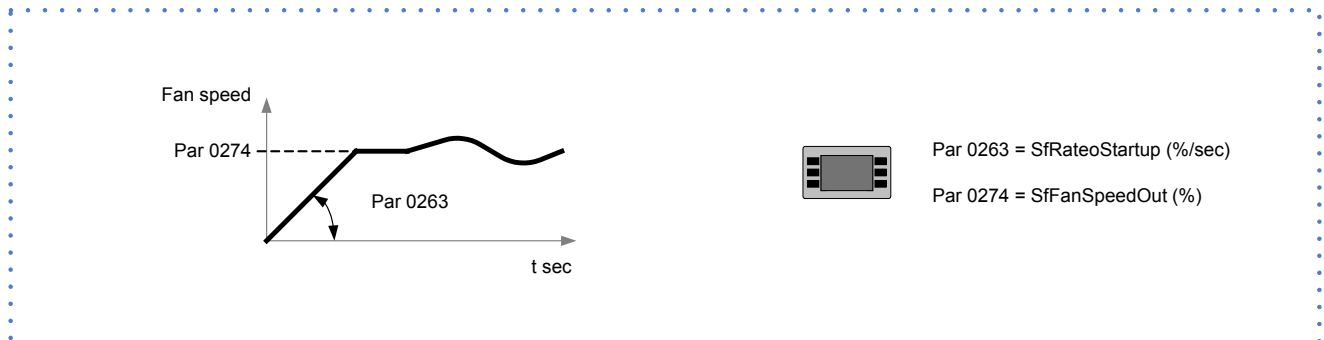

7.19 Application for low outdoor temperature

Option indicated for very cold climates, where the outside temperature can be between -10 and -30°C.

The option includes self-regulating heaters with thermostats that can protect the electrical panel from freezing to make sure it operates correctly.



The accessory is also active with unit OFF; the unit must remain powered.

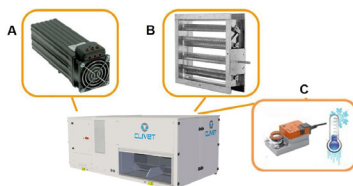

- A. heaters with thermostats
- B. damper
- C. motorised actuator

7.20 Demand limit

- ⚠ Menu accessible only after having entered the password.
 - ⚠ Access reserved only to specifically trained personnel.
 - ⚠ The parameter modification can cause irreversible damages.
- It is possible to limit the absorbed electric power with an external signal 0-10 Vcc.
The higher the signal is, the lower the number of compressors available to meet the thermal need.
- If only P0050: EnDemandLimit = 1
Path: Main menu / Unit parameters / Unit options / Demand limit

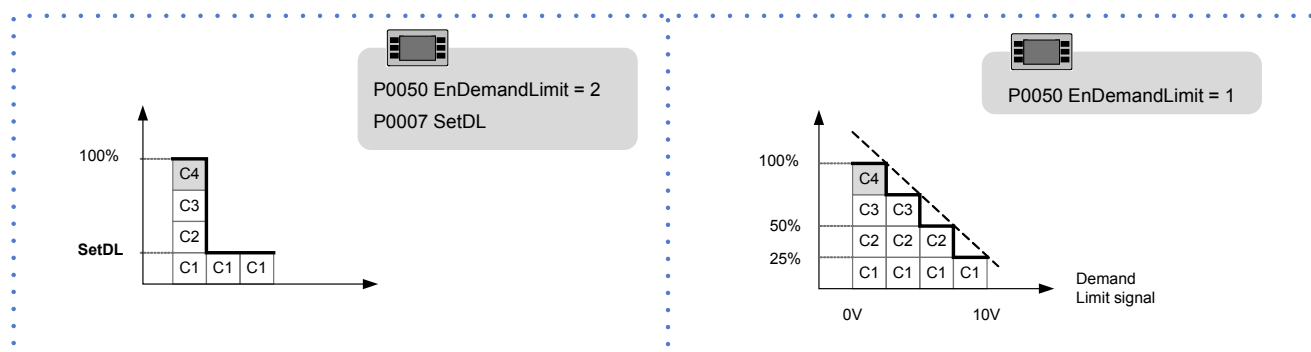

7.21 Start-up report

Identifying the operating objective conditions is useful to control the unit over time.

With unit at steady state, i.e. in stable and close-to-work conditions, identify the following data:

- total voltages and absorptions with unit at full load
- absorptions of the different electric loads (compressors, fans, pumps etc)
- temperatures and flows of the different fluids (water, air) both in input and in output from the unit
- temperature and pressures on the characteristic points of the refrigerating circuit (compressor discharge, liquid, intake)

The measurements must be kept and made available during maintenance interventions.

7.22 2014/68/UE PED directive

DIRECTIVE 2014/68/UE PED gives instructions for installers, users and maintenance technicians as well.

Refer to local regulations; briefly and as an example, see the following:

Compulsory verification of the first installation:

- only for units assembled on the installer's building site (for ex. Condensing circuit + direct expansion unit)









Certification of setting in service:

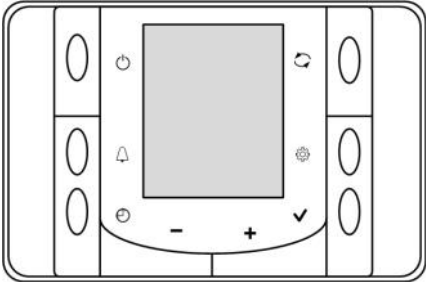









- for all the units

Periodical verifications:

- to be executed with the frequency indicated by the Manufacturer (see the "maintenance inspections" paragraph)

8 Control

| Keypad | Keys and function |
|---|---|
|  |  change of status: OFF, ON, ECO, FAN |
| |  ALARMS menu access (if available) |
| |  set TIME and DATE set SCHEDULER (prolonged pressure) |
| |  to browse through the menus to set values |
| |  to browse through the menus to set values |
| |  access to the STATUS menu to confirm your selection |
| |  to access the PARAMETERS menu (password) KEYPAD LOCK menu (password) |
| |  HEAT - COOL mode change CLEAN function (prolonged pressure) |

| Symbols | |
|--|---|
|  <p>ON / OFF OFF status. On the top field of the thermostat, the temperature and OFF indication are alternated every 2 seconds. When the status is OFF, changes to the SETPOINT and schedule are blocked.</p> |  <p>Humidifier / Dehumidifier mode The Humidifier mode is active If flashing, it means the Dehumidifier mode is active</p> |
|  <p>Automatic Mode: The temperature setpoint is in automatic mode. The user cannot change the setpoint value.</p> |  <p>Recirculation mode: The machine is in recirculation mode</p> |
|  <p>ECO mode: The machine is in economy mode.</p> |  <p>Compressor ON: At least one compressor is active</p> |
|  <p>HEAT mode * : The machine is in heat mode.</p> | |
|  <p>COOL mode: The machine is in cool mode.</p> |  <p>Alarm: There is at least one alarm Press the "alarm" key to view it</p> |
|  <p>Defrosting Mode: The machine is defrosting.</p> |  <p>Scheduling Mode: The scheduling is active.</p> |

Operational modes

MANUAL

The choice between HEATING or COOLING mode is manually carried out from keyboard, room thermostat or remote selector (see ELECTRIC CONNECTIONS chapter).

AUTOMATIC

The choice between HEATING or COOLING mode automatically happens from electronic module depending on the room temperature, detected by the probe in unit return . With temperatures above the cold set, the unit cools the room, with temperatures below the hot set, it heats.

ECO

In this operational mode the minor consumption compared to comfort is privileged:

the ECO-COOL set is higher than the COOLING set
the ECO-HEAT set is lower than the HEATING set

In this mode, the fan periodically activates to verify the room temperature and decide whether to activate or not the available resources to satisfy the set.

It can be activated from keyboard with MODE menu, using the time slots or from supervisor.

FAN

Ventilation only; all the resources devoted to thermoregulation are disabled (compressors, electric heaters, humidifier, etc).

Setpoint

MANUAL TEMPERATURE SETPOINT

The room setpoint can be MANUALLY modified from keyboard at parameter n. 01 ManSet = xx °C .

Starting from this value, the module determines 2 setpoint:

COOLING = maset + dead area/2 = xx +1°C

HEATING = maset - dead area/2 = xx -1°C

AUTOMATIC TEMPERATURE SETPOINT

The setpoint can also AUTOMATICALLY adjust to the outdoor temperature and some parameters variations (modifiable from after-sales assistance centres)

The choice between MANUAL or AUTOMATIC setpoint happens by modifying the parameter

53 En climatica =

0 manual operation

0 automatic operation

HUMIDITY SETPOINT

Only for unit with enthalpy control option.

In heating, the thermoregulator will activate the humidifier by modulating the power in order to humidify the room until reaching the set at parameter 5 SptUrHeat set.

In cooling, the thermoregulator will force compressors operation in order to dehumidify the room until reaching of the set at parameter 4 SptUrCool set.

In parallel, the thermoregulator will activate the post-heating.

SET POINT CO2

Only for units with CO2 / CO2+VOC probe option.

It is possible to manage the air renewal in room based on the CO2 concentration.

The outdoor air in room relation happens by privileging the thermoregulation requirements, therefore, only if: :

- in HEATING
the temperature is higher than the set hot - 2 °C
- in COOLING
the temperature is below the setcold – 2°C
- the outdoor temperature is above 16 °C

8.1 PARAMETERS MENU

press



16.3 C°
17:00



the access by password is reserved to qualified personnel, the parameters changes can cause malfunctions.

enter password (0047)



COD

confirm



scroll the parameters



P0
030.0

enable the parameter change
PO starts flashing



change the value of the parameter



P0
032.0

confirm the new value



select

to enable the new value and exit



ESC

when the time is displayed
it is possible to carry out other
operations



MANUAL SET POINT

To change the *manset* manual temperature Setpoint:
press



16.3 C°
17:00

The unit:
must be On
En Climate must be = 0

| keyboard code | Mnemonic | Description |
|---------------|-------------------------|---|
| 0 | SetUrCool | Relative humidity setpoint in Cool mode |
| 1 | SetURHeat | Relative Humidity setpoint in Heat mode |
| 2 | SetEcoCool | Temperature setpoint in cool economy mode |
| 3 | SetEcoHeat | Temperature setpoint in heat economy mode |
| 4 | SetCO2 | Air quality setpoint |
| 5 | EnClimatic | Enables setpoint from climate area |
| 6 | Control priority | Start-up/mode change controls priority ([0] keyboard [1] BMS) |
| 7 | EnModeAuto | Enables automatic mode change in relation to the return temperature |
| 8 | EnScheduler | Enables / disabling scheduler: 0 = disabled, 1 = enabled (P0061 service keypad) |

8.2 STATA MENU

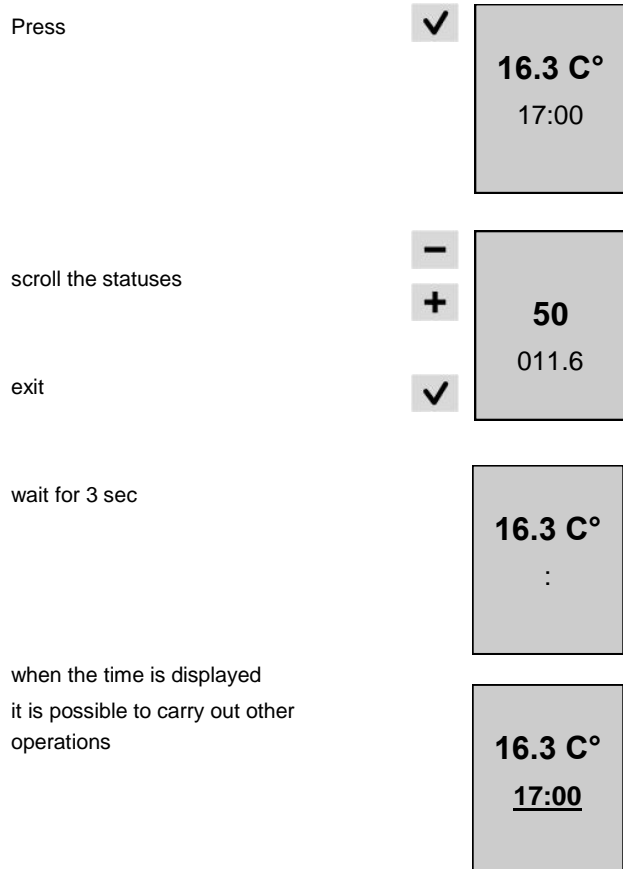

| Keyboard index | STATUS |
|----------------|-------------------------------|
| 0 | SupplyTemp_B2:AI-687 |
| 1 | OutdoorTemp_B3:AI-687 |
| 2 | RH% Return_X1:AI-955 |
| 3 | RH% External_X2:AI-955 |
| 4 | QualityAir_X2:AI-687 |
| 5 | Nr. active compressors |
| 6 | ActVclnt |
| 7 | %Cmd ExternalDamper_X7:AO-687 |
| 8 | PowerHum |

Example of status codification:

Supply temperature

Supply temp_B2:AI-687

B2 = electronic module connector code



AI = type of input/output: AI=Analogic input, DI= digital input, AO=analogic output, DO=digital output

687 = electronic module: 687=control unit, 985=compressor, 994=EEV driver,



8.3 DATE AND HOUR

Press  **16.3 C°**
17:00



HOUR digits start flashing



edit  **17:00**
 **17:00**
confirm 

MINUTE digits start flashing

edit  **17:00**
 **17:00**
confirm 

HOUR - MINUTE digits start flashing



choose format
24h / am - pm  **17:00**
 **17:00**

set
year, month, day  **16.3 C°**
 **17:00**



main menu 

8.4 BUTTON LOCK



Press for 4 sec.  **16.3 C°**
17:00



enter password
confirm  **COD**
 **---**

example:
T0 = "-" key
ON = active key
see codes-key table **T0**
ON









scroll the keys  **T1**
 **OFF**

select the key
(ALL starts flashing)  **ALL**
OFF

set active-ON / disabled-OFF
example:
ALL = OFF
all keys disabled  **ALL**
 **OFF**

select to confirm  **ESC**
 **ESC**

exit **16.3 C°**
17:00

| Key-code table | | | |
|----------------|---|--------|---|
| n. key | key | n. key | key |
| T0 |  | T5 |  |
| T1 |  | T6 |  |
| T2 |  | T7 |  |
| T3 |  | ALL | All keys |
| T4 |  | | |

8.5 TO VISUALIZE ALARM IN PROGRESS

Before resetting an alarm identify and remove its cause.
Repeated resets can cause irreversible damage.

press
only if the ALARM symbol is flashing

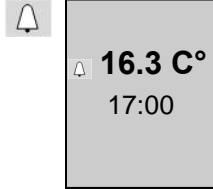

ee type of alarm (see table)

0 generic alarm (1 circuit1 alarm, etc.)

030 progressive alarm number

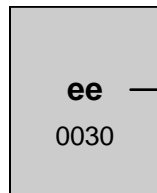

press

7 days since the alarm was triggered
17:00 alarm time

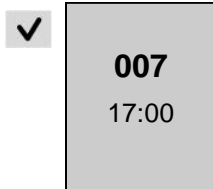

previous menu

scroll the alarms

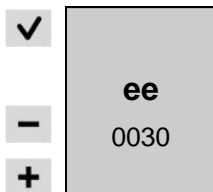

exit without alarms RESET

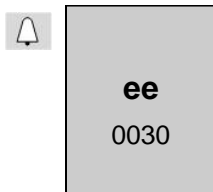

exit with alarms RESET:
scroll and select RES

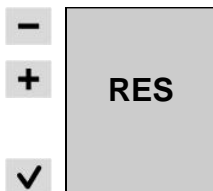

Type of alarm

| Code | Type | Restore |
|------|--------------|----------------------|
| ee | Electric | Automatic |
| eE | Electric | From Auto to manual* |
| EE | Electric | Manual |
| ii | Idraulic | Automatic |
| il | Idraulic | From Auto to manual* |
| II | Idraulic | Manual |
| ff | Refrigerator | Automatic |
| fF | Refrigerator | From Auto to manual* |
| FF | Refrigerator | Manual |
| aa | Aeraulic | Automatic |
| aA | Aeraulica | From Auto to manual* |
| AA | Aeraulica | Manual |

* After "n" times the alarm has been triggered, it is necessary to conduct a manual reset.

The code of the circuit 2 alarms is **2nn**:

example:

fF113:DI High pressure = circuit 1

fF213:DI High pressure = circuit 2

8.6 SCHEDULER

Enable scheduler (8.1 menu parametres)

It is possible to set up to 7 schedules (1 for every day of the week)

It is possible to set up to 6 status changes for each day (On, Off, Fan).

In the days not included in the schedule, the unit maintains the most recent status defined in the schedule.

Example:

- Sunday scheduled, 23h unit in OFF mode
- Monday not scheduled (-), the unit remains in - (OFF)

Scheduling example:

| Time | Event | 1 Monday | 2 Tuesday | 3 Wedne- sday | 4 Thursday | 5 Friday | 6 Saturday | 7 Sunday |
|-------|-------|-------------|--------------|---------------------|---------------|-------------|---------------|-------------|
| 05:30 | 1 | - (OFF) | FAN | - (OFF) | FAN | FAN | FAN | - (OFF) |
| 08:00 | 2 | FAN | ON | FAN | ON | ON | ON | FAN |
| 13:00 | 3 | FAN | ON | FAN | ON | ON | ON | FAN |
| 15:00 | 4 | FAN | ON | FAN | ON | ON | ON | FAN |
| 18:00 | 5 | FAN | ON | FAN | ON | ON | ON | FAN |
| 21:00 | 6 | OFF | OFF | OFF | OFF | OFF | OFF | OFF |

Scheduling customer:

| Time | Event | 1 Monday | 2 Tuesday | 3 Wedne- sday | 4 Thursday | 5 Friday | 6 Saturday | 7 Sunday |
|-------|-------|-------------|--------------|---------------------|---------------|-------------|---------------|-------------|
| 05:30 | 1 | | | | | | | |
| 08:00 | 2 | | | | | | | |
| 13:00 | 3 | | | | | | | |
| 15:00 | 4 | | | | | | | |
| 18:00 | 5 | | | | | | | |
| 21:00 | 6 | | | | | | | |

Sequence of operations:

1. Set weekly scheduling (see table example)
2. define days with the same scheduling (ex. days 2 = 4 = 5 = 6)
3. select days 2,4,5,6
4. set event 1 (event time, state Off - On - Fan)
5. set event 2,3, ecc..
6. select days 1,3,7
7. set event 1,2,3, ecc..

The most recent schedule saved overrides the existing one. For instance, if a day is included in two different schedules, the most recent one saved prevails.

Scheduling days 2,4,5,6

Scheduling the 1st day, also the other days of the week are automatically scheduled.

Press 2 sec
(only if the unit is not OFF)

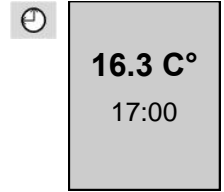

day 1 starts flashing
to go to day 2 press

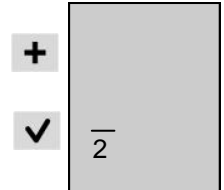

to schedule day 2 press
(2 stays steady = day 2 scheduled)

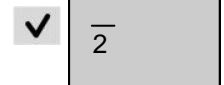

to exclude day 3 press

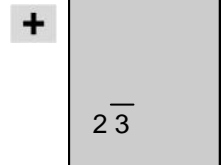

to schedule day 4 press
(4 starts flashing)



press

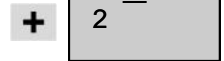

to schedule day 5 press
(5 starts flashing)



press

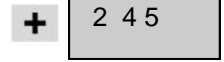

to schedule day 6 press
(6 starts flashing)



press

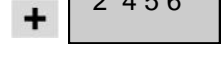

to exclude day 7 press

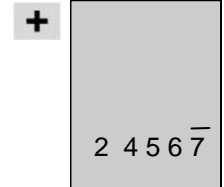

to confirm selected days press

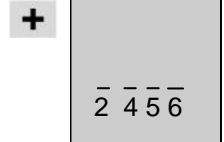

2 4 5 6 starts flashing

press

✓ **000**
--:--
1 3 7

Set event 1

example: Monday 05:30 FAN

press

-- starts flashing

✓ **000**
--:--
1 3 7

set

- event time

- **000**
05:--
+ 1 3 7

press

✓ 1 3 7

set

- event minutes

- **000**
05:30
+ 1 3 7

press

✓ 1 3 7

iset

- desired mode

0 = null, 1 = OFF, 2 = ECO,
3 = ON, 4 = Fan

- **001**
05:30
+ 1 3 7

press

✓ 1 3 7

Press

to set other the events 2,3,4,5,6

+ **001**
05:30
1 3 7

Ripeat from (Set event 1)

press 2 times to exit

🕒 **16.3 C°**
17:00

P flashing, active scheduling

P 16.3 C°
17:00
4

Modify scheduling

Example:

- day 5
- change events 3 and 4
- from ON to OFF

| Time | Event | 1 Monday | 2 Tuesday | 3 Wedne- sday | 4 Thursday | 5 Friday | 6 Saturday | 7 Sunday |
|-------|-------|-------------|--------------|---------------------|---------------|-------------|---------------|-------------|
| 05:30 | 1 | (OFF) | FAN | (OFF) | FAN | FAN | FAN | (OFF) |
| 08:00 | 2 | FAN | ON | FAN | ON | ON | ON | FAN |
| 13:00 | 3 | FAN | ON | FAN | ON | OFF | ON | FAN |
| 15:00 | 4 | FAN | ON | FAN | ON | OFF | ON | FAN |
| 18:00 | 5 | FAN | ON | FAN | ON | ON | ON | FAN |
| 21:00 | 6 | OFF | OFF | OFF | OFF | OFF | OFF | OFF |

Press 2 sec

🕒 **16.3 C°**
17:00

press

to schedule day 5 press

+ **5**

press

(5 stays steady)

✓ 5

press to exclude the other days

+ **5**

5 starts flashing

press

✓ 5

press 3 times (= event 3)

+ **003**
13:00
5

press 3 times

starts flashing 003 (= ON)

✓ **003**
13:00
5

select mode 002 (=OFF)

- 5

confirm

✓ **002**
13:00
5

press

✓

002
15:00
5

press 4 times (= event 4)

+

003
15:00
5

press 3 times
starts flashing 003 (= ON)

✓

003
15:00
5

select mode 002 (=OFF)

-

002
15:00
5

confirm

✓

002
15:00
5

press 2 times to exit

⏻

16.3 C°
17:00

8.7 SERVICE KEYPAD

| | | |
|--|--|---|
| | | <p>Function keys</p> <ul style="list-style-type: none"> Main menu Alarm display Exit Previous level Keyboard settings Up Increases value Down Decreases value Confirm Password |
|--|--|---|

8.8 DISPLAY MEANING

| | | | |
|-----------------------|-------------------------|------------|-----------------------------------|
| ActualSetPoint | temperature setting | 2 | installed compressors |
| T.In air | Return temperature | 3 | 1 - 0 Compressors ON |
| T.Out air | Supply temperature | | example : circuit 1 = 1 compr. On |
| ActualState | On / off / eco / pmp On | | circuit 2 = 0 compr. On |
| ActualMode | Cool : cooling | 50% | required power |
| | Heat : heating | | |

8.9 COMMON OPERATIONS

| | | |
|------------------------|--|---|
| ON, OFF, ECO | | main menu → cmd local status → scegliere OFF - ON - ECO - PUMP ON |
| change MODE | | main menu → cmd local mode → select COOL - HEAT |
| change SETPOINT | | main menu → unit parameters → setpoint |

8.10 MAIN MENU

Select 

| Main index | |
|-----------------|------|
| Cmd Local state | On |
| Cmd Local mode | Cool |
| Unit stata | |
| Unit parameters | |
| Scheduler | |

Select 

Confirm 

| Main index | |
|------------------------|-----------|
| Cmd Local state | On |
| Cmd Local mode | Cool |
| Unit stata | |
| Unit parameters | |
| Scheduler | |

| | |
|------------------------|---------------------------|
| Cmd Local state | OFF |
| | ECO |
| | ON |
| | Fan |
| Cmd Local mode | Cool |
| | Heat |
| Unit Stata | General |
| | Central |
| | Expansion |
| | Thermoregulator |
| | Stata C1 Circuit 1 * |
| | Thermostatic |
| | Bac |
| | Lon |
| Parameters Unit | SetPoint |
| | Unit Option |
| Scheduler | Scheduler |

Unit Stata → **page 49**

Input, output functioning variables.
See next pages tables
* Circuits number depend on unit's series .
The menu is repeated for each refrigerant circuit (circuit: circuit1, circuit2,.....;thermostatic: circuit1, circuit2,.....)

Setpoint Menu

| | |
|--------------------------|---|
| P0001: ManSet | Manual temperature Setpoint |
| P0002: SetEcoCool | Temperature setpoint in cool economy mode |
| P0003: SetEcoHeat | Temperature setpoint in heat economy mode |
| P0004: SetUrCool | Relative humidity setpoint in Cool mode |
| P0005: SetURHeat | Relative Humidity setpoint in Heat mode |
| P0006: SetCO2 | Air quality setpoint |

Unit Option Menu

| | |
|--------------------------------|---|
| P0053: EnClimate | Enables setpoint from climate area |
| P0054: Control priority | Start-up/mode change controls priority ([0] keyboard [1] BMS) |
| P0058: EnModeAuto | Enables automatic mode change in relation to the return temperature |

8.11 SCHEDULER

It is possible to set 6 events (Off, Eco, On, Recirculating) for each week day.

Scheduler must be enabled:

display : actual value = On

pag **xy** : unit parameters service-maintenance, P0500=1

Select 

| Main index | |
|----------------------------|------|
| Cmd Local state | On |
| Cmd Local mode | Cool |
| Unit stata | |
| Unit parameters | |
| System Objects | |
| <u>Schedulatore</u> | |

Confirm 

Select 

| Main index | |
|--------------------|------------|
| Actual value | On |
| 01 : Monday | Off |
| 01 : Tuesday | Off |
| 01 : Wednesday | Off |
| 01 : Thursday | Off |
| 01 : Friday | Off |

Confirm 

Select 

| d01 : Monday | |
|---------------|--------------|
| Scheduled day | Active |
| Time 1 | 00:00 |
| Value 1 | ECO |
| Time 2 | 5:00 |
| Value 2 | ON |
| Time 3 | 17:00 |
| Value 3 | ECO |
| Time 4 | 20:00 |
| Value 4 | OFF |

Confirm 

Setting

Exit 

Select 

| d01 : Monday | |
|----------------|------------|
| Scheduled day | Active |
| Time 1 | xx:yy |
| Value 1 | Eco |
| Time 2 | |
| Value 2 | |
| Time 3 | |
| Value 3 | |

Confirm 

Setting

Exit 

8.12 KEYBOARD SETTINGS

Press 3 sec 

Select 

Confirm 

| HMI settings | |
|------------------|--|
| local connection | |

exit : 

| HMI settings | |
|-------------------------|-------|
| V9.08 | B0024 |
| Backlight color | Blue |
| Backlight turn off time | 0 |
| Contrast | 60 |
| Brightness | 100 |
| Firmware Update | No |

To exit :

Select 

Confirm 

| HMI settings | |
|--------------------------------|--|
| <u>local connection</u> | |

8.13 TO VISUALIZE ALARM IN PROGRESS

 Before resetting an alarm identify and remove its cause.
Repeated resets can cause irreversible damage.

Press 

alarm log detail

+ eE001 : Monitore fase : Fault

1 Critico (A)

14.02.2012 11.30.10

Press 

alarm list

Reset Passive 1

+ eE001 : Monitore fase : Fault

Press 

Press 

alarm log

Reset Passivo 10

+ eE001 : Monitore fase : Fault

- EE003 : Guasto P1 Util : Ok

+ EE003 : Guasto P1 Util : Fault

- eE001 : Monitore fase : Fault = active alarm
- - EE003 : Guasto P1 Util : Ok = resetted alarm

RESET ALARM

Press 

alarm log detail

+ eE001 : Monitore fase : Fault

1 Critico (A)

14.02.2012 11.30.10

Press 

alarm list

Reset Passive 1

+ eE001 : Monitore fase : Fault

Press 

Slide 

alarm log

Reset Passivo 10

+ eE001 : Monitore fase : Fault

- EE003 : Guasto P1 Util : Ok

+ EE003 : Guasto P1 Util : Fault

.....

Press 3 sec. 

Enter password:
Maintenance
Developer

Password

Password

0 - - -

Confirm 

Press 

Select 

Confirm 

alarm list

Reset Passive 1

+ eE001 : Monitore fase : Fault

Select 

Confirm 

Passivo

Attivo

Select 

alarm list

Reset Passivo 0

Exit:
Press 3 sec. 

Select 

Confirm 

password management

Log off

Cambia PSS user

Cambia PSS service

Cambia PSS manufacturer

ALARM LOG RESET

Press  **alarm log**

Reset **Passivo 10**

+ eE001 : Monitore fase : Fault
 - EE003 : Guasto P1 Util : Ok
 + EE003 : Guasto P1 Util : Fault

Press 3 sec. 

| | |
|------------------|----------|
| 10.02.2012 | 10:15:30 |
| SetPointAttuale | 8.5°C |
| T.InH2Outilizzo | 10.5°C |
| T.OutH2Outilizzo | 12.5°C |
| StatoAttuale | ON |
| ModoAttuale | Cool |
| 12 | 1 1 100% |

Press 3 sec. 

Password

Password
 0 - - -

Insert password:
 Maintenance
 Manufacturer

Confirm 

Select 

password management

Log off
 Cambia PSS utente
 Cambia PSS service
 Cambia PSS costruttore

Confirm 

Press  **alarm log**

Reset **Passivo 10**

+ eE001 : Monitore fase : Fault
 - EE003 : Guasto P1 Util : Ok
 + EE003 : Guasto P1 Util : Fault

Select 

Alarm cnf

AlarmSnapshot 0
 Lista allarmi :
 Ordinamento 1 Ora
 Ordinamento 2 Ora
 Ordine decrescente Passive
 Storico allarmi :
Reset

Confirm 

Select 

Confirm 

Execute

Select 

Allarmi cnf

AlarmSnapshot 0
 Lista allarmi :
 Ordinamento 1 Ora
 Ordinamento 2 Ora
 Ordine decrescente Passive
 Storico allarmi :
Reset

8.14 MAIN MENÙ - INSTALLER USE

Press 3 sec.



| | |
|----------|--|
| Password | |
| Password | |
| 0 - - - | |

insert maintenance password



| | |
|-----------------|------|
| Main index | |
| Cmd Local state | On |
| Cmd Local mode | Cool |
| Unit stata | |
| Unit parameters | |
| Scheduler | |

Select



| | |
|------------------------|------|
| Main index | |
| Cmd Local state | On |
| Cmd Local mode | Cool |
| Unit stata | |
| <u>Unit parameters</u> | |
| System Objects | |
| Scheduler | |

Confirm



Unit Stata

Circuit stata

Circuit 1 stata

Circuit 1 I/O stata

Thermostatic stata

General stata

Central POL687-IO

Expansion POL955 - I/O

Thermoregulator

exFlow option

Unit parameters

SetPoint

Unit setting

circuit setting

Circuit C1

Thermostatic C1

Unit option

Thermoregulator

Integrations

Compressor

Correction SH

Source

Ventilation

Supply fan

Return fan

Circuit alarms

Defrost - not used

Humidity control

Recovery renewal

Reset usure

Sensor settings

Serial communication

8.15 ALLARMS - TAB 1

| ID | Description | Reset |
|-------|--|-------|
| AA003 | Fire | M |
| aa004 | Dirty filters | A |
| aa008 | Supply air flow | A |
| eE001 | Phase monitor | A/M |
| EE002 | Compartment opening | M |
| EE005 | Electrostatic Filters | A |
| ee006 | POL955 Board Offline | A |
| eE007 | Supply fan protections | A/M |
| eE009 | Return, exhaust fan protections | A/M |
| EE010 | Additions high temp. | M |
| EE011 | Addition heater | M |
| ee020 | POL822 keyboard offline | A |
| ee027 | Return temperature probe | A |
| ee028 | Delivery temperature probe | A |
| ee029 | Outside temperature local probe | A |
| ee030 | Demam Limit input | A |
| ee031 | Relative return humidity probe | A |
| ee032 | Outside relative Humidity probe | A |
| ee033 | Air Quality probe | A |
| ee035 | Supply fan Pdiff. Probe | A |
| ee036 | External fan Pdiff. probe | A |
| ee037 | Return fan Pdiff. probe | A |
| ee038 | Coil antifreeze probe | A |
| ee039 | Supply pressure probe | A |
| ee040 | Signal from humidifier board | A |
| ee041 | Alarm from humidifier board | A |
| ee042 | Alarm from humidifier board | A |
| ee043 | Humidifier board offline | A |
| ee044 | POL925 (1) board offline | A |
| ee045 | POL925 (1) board offline | A |
| ee046 | Ambient pressure probe failure | A |
| ee101 | Circuit 1 module disconnection on ProcessBus | A |
| ee102 | Thermostatic valve driver timeout | A |
| ee104 | Thermostatic valve block | A |
| EE106 | Comp 1 Protec. | M |
| EE107 | Comp 2 Protec. | M |
| EE108 | Comp 3 Protec. | M |
| EE118 | Source Protec. | M |
| ee122 | Discharge temperature C1 probe | A |
| ee123 | Discharge temperature C2 probe | A |
| ee124 | Discharge temperature C3 probe | A |
| ee125 | Source 1 Temp. probe | A |
| ee126 | Source 2 Temp. probe | A |
| ee127 | Suction Temp. probe | A |

ALLARMS - TAB 2

| ID | Description | Reset |
|-------------|--|-------|
| ee128 | Discharge Pressure probe | A |
| ee129 | Suction Pressure probe | A |
| Ee137 | timeout | |
| Ee201 - 237 | Ee201 circuit 2 fault = ee 101 circuit 1 fault etc | A |
| ee202 | driver 1 module disconnection on ProcessBus | A |
| ee204 | thermostatic valve block | A |
| ff105 | Overheating below minimum limit | A |
| fF109 | DI Low Pressure | A/M |
| ff110 | Cool Low pressure Pre-alarm | A |
| ff111 | Low Heat Pressure pre-alarm | A |
| fF112 | AI Low Pressure | A/M |
| fF113 | DI High Pressure | A/M |
| ff114 | High pressure pre-alarm | A |
| fF115 | AI High Pressure | A/M |
| ff116 | Max. Press. rat. pre-alarm | A |
| fF117 | Min Press. Rat. pre-alarm | A/M |
| FF119 | Max Press. Rat. alarm | M |
| FF134 | Empty circuit alarm | M |
| FF136 | Defrost not manageable due to activated Demand Limit | M |
| Ff205 - 234 | ff205 circuit 2 fault = ff 105 circuit 1 fault etc | A |
| il012 | Addition antifreeze | A |
| il120 | Source flow | A |
| Il121 | Source frost | M |
| il220 | Source flow | M |
| Il221 | Source frost | M |

Type of alarm

A automatic reset

M manual reset

A/M automatic reset , after N alarm → manual reset

STATA - TAB 1

| MENU | ID | Short description | Description |
|----------------------------|----|-------------------------------|---|
| 1 Main Page | - | Machine status | Current unit status [0]:Off, [1]:ECO, [2]:ON, [3]:FAN |
| 1 Main Page | - | Machine mode | Current unit mode [0]:COOL, [1]:HEAT |
| 1 Main Page | - | Current setpoint | Current unit setpoint |
| 1 Main Page | - | No. of steps used | Number of compressors currently activated |
| 10 Main Index | - | Clean | Clean control from HMI |
| 3001 Central POL687 - IO | - | IntakeTemp_B1:AI-687 | Return temperature detected by the main board's analogue input |
| 3001 Central POL687 - IO | - | OutdoorTemp_B3:AI-687 | Outside temperature |
| 3001 Central POL687 - IO | - | SupplyTemp_B2:AI-687 | Supply temperature |
| 3001 Central POL687 - IO | - | %Cmd RicicDamper_X1:AO-687 | Recirculation damper opening control percentage |
| 3001 Central POL687 - IO | - | QualityAir_X2:AI-687 | Air quality value from analogical input |
| 3001 Central POL687 - IO | - | SupplyPDiff_X3:AI-687 | Supply fan differential pressure to calculate air flow rate |
| 3001 Central POL687 - IO | - | ExternalPDiff_X4:AI-687 | Return external differential pressure to examine pressure drops on the return channel and, if necessary, adjust the external damper |
| 3001 Central POL687 - IO | - | ON-OFFRem_DU1:DI-687 | On/off digital input status (open OFF, closed ON) |
| 3001 Central POL687 - IO | - | Heat/CoolRem_DU2:DI-687 | Digital input status for mode change (open COOL, closed HEAT) |
| 3001 Central POL687 - IO | - | PhaseControl_D1:DI-687 | Phase monitor alarm input status (open ALARM) |
| 3001 Central POL687 - IO | - | Ovl SupplyFan_DL1:DI-687 | Supply fan thermal digital input status (open ALARM) |
| 3001 Central POL687 - IO | - | Ovl RipEspFan_DL2:DI-687 | Return/exhaust fan thermal digital input status (open ALARM) |
| 3001 Central POL687 - IO | - | Diff. Filters_D2:DI-687 | Supply air filters differential input status (open INSUFFICIENT FLOW) |
| 3001 Central POL687 - IO | - | Fire Alarm_X8:DI-687 | Fire alarm input status (open ALARM) |
| 3001 Central POL687 - IO | - | %Cmd Supply Fan_X5:AO-687 | Modulating supply fan control percentage |
| 3001 Central POL687 - IO | - | %Cmd ExternalDamper_X7:AO-687 | External damper opening control percentage |
| 3001 Central POL687 - IO | - | %Cmd EjectionDamper_X6:AO-687 | Exhaust damper opening control percentage |
| 3001 Central POL687 - IO | - | Cmd CumAlarm_Q2:DO-687 | Alarm cumulative control status |
| 3001 Central POL687 - IO | - | Cmd EjectionDamper_Q5:DO-687 | Exhaust damper/fan control status |
| 3001 Central POL687 - IO | - | Cmd Humidifier_Q6:DO-687 | Humidifier control status |
| 3001 Central POL687 - IO | - | Cmd SupplyFan_Q3:DO-687 | Supply fan control status |
| 3001 Central POL687 - IO | - | Cmd ReturnFan_Q4:DO-687 | Return fan control status |
| 3001 Central POL687 - IO | - | Cmd ModeUnit_Q1:DO-687 | Unit mode control status (open COOL, closed HEAT) |
| 3001 Central POL687 - IO | - | AntifreezeHeater_Q8 | Control status of the antifreeze heaters for source side water exchangers |
| 3002 Expansion POL955 - IO | - | ReturnPDiff_X4:AI-955 | Return fan differential pressure to calculate air flow rate |
| 3002 Expansion POL955 - IO | - | Freeze Addition_X3:AI-955 | Water coil output temperature for additions' antifreeze function |
| 3002 Expansion POL955 - IO | - | RH% outdoor_X2:AI-955 | Outside relative humidity value |
| 3002 Expansion POL955 - IO | - | Supply Pressure_X5:AI-955 | Absolute pressure status on supply channel |
| 3002 Expansion POL955 - IO | - | RH% Return_X1:AI-955 | Relative return humidity value |
| 3002 Expansion POL955 - IO | - | HT Addition_X6:DI-955 | Additions' high temperature alarm input status |
| 3002 Expansion POL955 - IO | - | Ovl Addition_X7:DI-955 | Addition protections alarm input status |
| 3002 Expansion POL955 - IO | - | Supply Flux_X8:DI-955 | Supply air flow switch status |
| 3002 Expansion POL955 - IO | - | %Cmd Addition_Y2:AO-955 | Integration element control percentage |
| 3002 Expansion POL955 - IO | - | %Cmd Return Fan_Y1:AO-955 | Return fan control percentage |
| 3002 Expansion POL955 - IO | - | Cmd Addition Pump_Q1:DO-955 | Additions' pump control for water coil |
| 3002 Expansion POL955 - IO | - | Cmd Addition 1_Q2:DO-955 | Addition 1 control |

STATA - TAB 2

| MENU | ID | Short description | Description |
|----------------------------|----|---|---|
| 3002 Expansion POL955 - IO | - | Cmd Addition 2_Q2:DO-955 | Addition 2 control |
| 3002 Expansion POL955 - IO | - | Cmd Addition 3_Q2:DO-955 | Addition 3 control |
| 3003 Thermoregulator | 1 | Startup phase | Start-up phase |
| 3003 Thermoregulator | 2 | Time to end startup | Start-up end timer |
| 3003 Thermoregulator | 3 | Info to compressor | Information on the compressors |
| 3003 Thermoregulator | 4 | Info to freecooling/heatingFCHMsg | Freecooling/heating information |
| 3003 Thermoregulator | 5 | Maximum power available for freecooling/heating | Maximum power available for freecooling |
| 3003 Thermoregulator | 6 | Info to addition | Information on the additions |
| 3003 Thermoregulator | 7 | Thermoreg. total request | Thermoreg. total request |
| 3003 Thermoregulator | 8 | Thermoreg. compressor request | Thermoreg. compressor request |
| 3003 Thermoregulator | 9 | Thermoreg. freecooling/heating request | Thermoreg. freecooling/heating request |
| 3003 Thermoregulator | 10 | Thermoreg. addition request | Thermoreg. addition request |
| 3003 Thermoregulator | 11 | Actual compressor limit for supply T | Power limit of the compressors for supply temp.: |
| 3003 Thermoregulator | 12 | Actual fch limit for supply T | Freecooling/heating power limit for supply temp.: |
| 3003 Thermoregulator | 13 | Actual addition limit for supply T | Power limit of the additions for supply temp.: |
| 3003 Thermoregulator | 14 | Thermo req. compressor | Reg. requested for the compressors |
| 3003 Thermoregulator | 15 | Thermo req. Fch | Reg. requested for freecooling/heating |
| 3003 Thermoregulator | 16 | Fch state | Freecooling/heating status |
| 3003 Thermoregulator | 17 | Actual request for addition | Reg. requested for the additions |
| 3003 Thermoregulator | 18 | Addition state | Additions' status |
| 3003 Thermoregulator | 19 | CntDwn start regulation | Countdown to start regulation |
| 3003 Thermoregulator | 20 | CntDwn stop fan | Countdown to stop fans |
| 3003 Thermoregulator | 21 | Wait insert step | Minimum waiting time to enable power |
| 3003 Thermoregulator | 22 | Wait release step | Minimum waiting time to release power |
| 3003 Thermoregulator | 23 | Enth. outdoor | External air enthalpy |
| 3003 Thermoregulator | 24 | Enth. Return | Return air enthalpy |
| 3003 Thermoregulator | 25 | US outdoor | External air specific humidity |
| 3003 Thermoregulator | 26 | US return | Return air specific humidity |
| 3003 Thermoregulator | 27 | Renoval available | Renewal availability |
| 3003 Thermoregulator | 28 | CO2BMS | CO2 value passed BY BMS |
| 3003 Thermoregulator | 29 | Modulation external damper for CO2 | External damper modulation for CO2 |
| 3003 Thermoregulator | 30 | Correction external damper for Pdiff | External damper adjustment for diff. pressure |
| 3003 Thermoregulator | 31 | Power Humidifier | Humidifier power |
| 3003 Thermoregulator | 32 | Humidifier command | Humidifier control |
| 3003 Thermoregulator | 33 | H2O valve command | Adiabatic humidifier control |
| 3003 Thermoregulator | 34 | Power dehumidification | Post-heating power |
| 3003 Thermoregulator | 35 | Valve postheat state | Post-heating valve status |
| 3003 Thermoregulator | 36 | CPYCYlHr | Cylinder hours CPY humidifier |
| 3003 Thermoregulator | 37 | CPYHr | Operating hours CPY humidifier |
| 3003 Thermoregulator | 38 | CPYStage | CPY humidifier operating stage |
| 3003 Thermoregulator | 39 | CPYStatus | CPY humidifier operating status |

STATA - TAB 3

| MENU | ID | Short description | Description |
|---------------------------|------|-----------------------------|--|
| 3003 Thermoregulator | 40 | CPYCurrent | CPY humidifier absorbed current |
| 3003 Thermoregulator | 41 | CPYIstSteam | CPY humidifier output |
| 3003 Thermoregulator | 42 | Supply Q Air | Supply air flow rate |
| 3003 Thermoregulator | 43 | Return Q Air | Return air flow rate |
| 3003 Thermoregulator | 44 | Supply temp. ctrl low power | Supply temperature control activation status for low capacities |
| 3003 Thermoregulator | 45 | Max mod. damper low power | Maximum renewal for supply limit |
| 3003 Thermoregulator | 46 | SetActPAmbExt | Current external/return pressure setpoint |
| 3003 Thermoregulator | 47 | PressRoomExFlow | Status of the ambient pressure detector – ExFlow opt. |
| 3003 Thermoregulator | 48 | Nr Extractor Run ExFlow | Number of active extractors – ExFlow option |
| 3003 Thermoregulator | 49 | ExFlow Modulation | External damper modulation associated with ExFlow opt. |
| 3101 Circuit C1 Stata | 1100 | CMP1 starts | Compressor 1 start-ups |
| 3101 Circuit C1 Stata | 1101 | CMP2 starts | Compressor 2 start-ups |
| 3101 Circuit C1 Stata | 1102 | CMP3 starts | Compressor 3 start-ups |
| 3101 Circuit C1 Stata | 1104 | Source starts | Source motor start-ups |
| 3101 Circuit C1 Stata | 1105 | Hours Comp.1 | Compressor 1 hours |
| 3101 Circuit C1 Stata | 1106 | Hours Comp.2 | Compressor 2 hours |
| 3101 Circuit C1 Stata | 1107 | Hours Comp.3 | Compressor 3 hours |
| 3101 Circuit C1 Stata | 1108 | HoursScrew | Screw compressor hours |
| 3101 Circuit C1 Stata | 1109 | HoursSource | Source motor hours |
| 3101 Circuit C1 Stata | 1110 | Total steps | Total amount of active steps on the circuit |
| 3101 Circuit C1 Stata | 1111 | Comp.1 status | 0=Free 1=Active 2=Timed 3=Not enabled |
| 3101 Circuit C1 Stata | 1112 | Comp.2 status | 0=Free 1=Active 2=Timed 3=Not enabled |
| 3101 Circuit C1 Stata | 1113 | Comp.3 status | 0=Free 1=Active 2=Timed 3=Not enabled |
| 3101 Circuit C1 Stata | 1114 | Current cap. | Capacity currently employed on the circuit |
| 3101 Circuit C1 Stata | 1115 | Requested cap. | Capacity requested on the circuit |
| 3101 Circuit C1 Stata | 1116 | Pressure ratio | Compression ratio status (1+Hp/1+LP) |
| 3101 Circuit C1 Stata | 1117 | FANPreAlarm | Status of the maximum ventilation pre-alarm in progress 0=Off 1=On |
| 3101 Circuit C1 Stata | 1118 | Defrost delay | Current value of the countdown towards the cycle inversion due to defrosting. (defrosting starts when the value reaches zero) |
| 3101 Circuit C1 Stata | 1119 | Defrost status | Indicates the defrosting status 0=DfrOff (Cycle inversion phase for defrosting phase NOT active) 1=DfrON (Cycle inversion phase for defrosting phase ACTIVE) |
| 3101 Circuit C1 Stata | 1120 | HWErr | 0=Off 1=On_Hardware error of the POL94U module that does not preclude the possibility of moving the valve or closing it. Possible causes: anomalous voltage values in the valve motor |
| 3101 Circuit C1 Stata | 1121 | BlckingHWErr | 0=Off 1=On_Hardware error of the POL94U module that prevents the electronic valve from moving. Possible causes: UPS not available, wrong POL94U Bios, HW POL94U Error, Disconnected EEV Motor, calibration error associated with configuration parameters. |
| 3101 Circuit C1 Stata | 1122 | FailSafeSta | 0=Off 1=On_Active block status |
| 3101 Circuit C1 Stata | 1123 | UPSNotAval | 0=Off 1=On_UPS failure |
| 3101 Circuit C1 Stata | 1124 | CircWarning | Status associated with minor alarm on the circuit |
| 3101 Circuit C1 Stata | 1125 | CircBlock | Status associated with circuit block alarm |
| 3101 Circuit C1 Stata | 1126 | ThTempDischarge | Theoretical discharge temperature |
| 3102 Circuit C1 -IO Stata | - | T.DischargeC1_B1:AI-985 | Compressor 1 discharge temperature |

STATA - TAB 4

| MENU | ID | Short description | Description |
|----------------------------|------|---------------------------|--|
| 3102 Circuit C1 -IO Stata | - | T.DischargeC2_B2:AI-985 | Compressor 2 discharge temperature |
| 3102 Circuit C1 -IO Stata | - | T.DischargeC3_X2:AI-985 | Compressor 3 discharge temperature |
| 3102 Circuit C1 -IO Stata | - | T.Source1_B3:AI-985 | Source 1 temperature (for machines with reversible air source on gas = Probe 1 on the source coil. For machines with water source = Source input probe) |
| 3102 Circuit C1 -IO Stata | - | T.Source2_X1:AI-985 | Source 2 temperature (for machines with reversible air source on gas = Probe 2 on the source coil. For machines with water source = Source output probe) |
| 3102 Circuit C1 -IO Stata | - | T.Suction_X2:AI-94U | Intake temperature |
| 3102 Circuit C1 -IO Stata | - | DemandLimit_X2:AI-985 | Analogue input for demand limit function |
| 3102 Circuit C1 -IO Stata | - | P.Discharge_X3:AI-985 | High pressure transducer |
| 3102 Circuit C1 -IO Stata | - | P.Suction_X1:AI-94U | Low pressure transducer |
| 3102 Circuit C1 -IO Stata | - | Ovl Cmp1_D1:DI-985 | 0=Fault 1=OK Status of the thermal protection contact of compressor 1 |
| 3102 Circuit C1 -IO Stata | - | Ovl Cmp2_D2:DI-985 | 0=Fault 1=OK Status of the thermal protection contact of compressor 2 |
| 3102 Circuit C1 -IO Stata | - | Ovl Cmp3_D3:DI-985 | 0=Fault 1=OK Status of the thermal protection contact of compressor 3 |
| 3102 Circuit C1 -IO Stata | - | SourceFlow_X4:DI-985 | 0=Fault 1=OK Status of the source flow contact (Active only on machines with water source) |
| 3102 Circuit C1 -IO Stata | - | LP_X7:DI-985 | 0=Fault 1=OK Status of the low-pressure pressure switch contact |
| 3102 Circuit C1 -IO Stata | - | Cmpmnt opening_DL1:DI-985 | 0=Fault 1=OK Status of the machine compartments opening contact |
| 3102 Circuit C1 -IO Stata | - | HP_X8:DI-985 | 0=Fault 1=OK Status of the high-pressure pressure switch contact |
| 3102 Circuit C1 -IO Stata | - | Ovl Source_DL2:DI-985 | 0=Fault 1=OK Status of the thermal protection contact of the source motors |
| 3102 Circuit C1 -IO Stata | - | ElectFilter_X5:DI-985 | 0=Fault 1=OK Status of the electrostatic filters' protection contact |
| 3102 Circuit C1 -IO Stata | - | %Cmd Source_X6:AO-985 | Percentage value of the status of the control signal of the modulating source motor_X6:AO-985 |
| 3102 Circuit C1 -IO Stata | - | Cmd Cmp1_Q2:DO-985 | 0=Off 1=On_Status of compressor 1 control_Q2:DO-985 |
| 3102 Circuit C1 -IO Stata | - | Cmd Cmp2_Q3:DO-985 | 0=Off 1=On_Status of compressor 2 control_Q3:DO-985 |
| 3102 Circuit C1 -IO Stata | - | Cmd Cmp3_Q4:DO-985 | 0=Off 1=On_Status of compressor 3 control_Q4:DO-985 |
| 3102 Circuit C1 -IO Stata | - | Cmd Sorg_Q1:DO-985 | 0=Off 1=On_Status of source motor control_Q1:DO-985 |
| 3102 Circuit C1 -IO Stata | - | Cmd Inj.Cmp1_Q5:DO-985 | 0=Off 1=On_Status of the compressor 1 liquid injection valve_Q5:DO-985 |
| 3102 Circuit C1 -IO Stata | - | Cmd Inj.Cmp2_Q7:DO-985 | 0=Off 1=On_Status of compressor 2 liquid injection valve_Q7:DO-985 |
| 3102 Circuit C1 -IO Stata | - | Cmd Inj.Cmp3_Q8:DO-985 | 0=Off 1=On_Status of compressor 3 liquid injection valve_Q8:DO-985 |
| 3102 Circuit C1 -IO Stata | - | Cmd YV4 vie_Q6:DO-985 | 0=Off 1=On_Status of control of the cycle inversion valve_Q6:DO-985 |
| 3102 Circuit C1 -IO Stata | - | Cmd Digital_DO2:DO-985 | 0=Off 1=On_Status of button valve control for PWM compressors_DO2:DO-985 |
| 3200 Thermostatic C1 Stata | 1200 | SHSpOp | Operating overheating setpoint net with SH and MET adjustments |
| 3200 Thermostatic C1 Stata | 1201 | AlCalSuctSprHtP | Current overheating value calculated |
| 3200 Thermostatic C1 Stata | 1202 | ECVState | 0 = Idle 1 = ECVAlarm 2 = FailSafe 3 = Referencing 4 = Positioning 5 = Positioned 6 = ECVWaiting 7 = FastClosing |
| 3200 Thermostatic C1 Stata | 1203 | EEVSH_Limiter | Maximum valve opening determined by the minimum SH control function |
| 3200 Thermostatic C1 Stata | 1204 | EEVLET_Limiter | Status of the minimum LET intake temperature control |

STATA - TAB 5

| MENU | ID | Short description | Description |
|--|------|-------------------|---|
| 3200 Thermostatic C1 Stata | 1205 | EEVMode | 0=Idle (motor off) 1=Init (valve initialised when completely closed) 2=Manual (valve controlled in manual mode) 3=Control (the valve conducts adjustments to control SH) |
| 3200 Thermostatic C1 Stata | 1206 | Prepos | Positioning % required for thermostatics |
| 3200 Thermostatic C1 Stata | 1207 | ECVSetPos | Opening percentage of the valve when EEVMod = Manual |
| 3200 Thermostatic C1 Stata | 1208 | ECVMode | 0 = Idle 1 = Init 2 = Position 3 = FastClose |
| 3200 Thermostatic C1 Stata | 1209 | SHPIDOut | % value of the PID output to adjust the valve |
| 3200 Thermostatic C1 Stata | 1210 | EEVStatus | 0 - Closed (Ready) 1 - StartUpPositioning 2 - StartUpPositioned 3 - SuperHeat 4 - Prepositioning 5 - MET 6 - LET 7 - Closing 8 - PumpDown 9 - DangAlarm 10 - PumpDownStartUp 11 - ECVAlarm 12 - MinSHLmtr 13 - WaitValveClose 255 - Warning |
| 3200 Thermostatic C1 Stata | 1211 | SetPosSteps | Control of the number of steps the valve must reach to adjust overheating |
| 3200 Thermostatic C1 Stata | 1212 | SetPos% | Opening % control of the valve to adjust overheating |
| 3200 Thermostatic C1 Stata | 1213 | Pol94xCommOK | 0=NotOK 1=OK_Connection status of the POL94U module on processbus |
| 3200 Thermostatic C1 Stata | 1214 | ActPos% | % value of the current status of the EEV valve |
| 3200 Thermostatic C1 Stata | 1215 | ActPosSteps | Current number of steps of the EEV valve |
| 3200 Thermostatic C1 Stata | 1216 | ECVMode | 0 = Idle 1 = Init 2 = Position 3 = FastClose. |
| 3200 Thermostatic C1 Stata | 1217 | ECVState | 0 = Idle 1 = ECVAlarm 2 = FailSafe 3 = Referencing 4 = Positioning 5 = Positioned 6 = ECVWaiting 7 = FastClosing |
| Circuit 2 stata : 2100 circuit 2 = 1100 circuit 1 | | | |

| MENU | ID | Short description | Description |
|----------------------------|-----|----------------------------|--|
| 4300 ModBus | 750 | ModBusBios | Bios version of the ModBus RTU expansion module |
| 4301 BacNet | 700 | BacnetIPModul | Relative status with the Bacnet module 0=Absent 1 = Present |
| 4301 BacNet | 701 | BacnetIPState | 0=Null 1=Init 2=OK |
| 4301 BacNet | 702 | BacnetCnf | 0=NotOK 1=OK (se Current IP = Set IP, Current MASK = Set MASK, Current DHCP= Set DHCP allora OK) |
| 4301 BacNet | 703 | BacNetBios | Versione bios del modulo espansione BacNet |
| 4302 LonWorks | 800 | LonID | Universal identification status of the Lon device |
| 4302 LonWorks | 801 | LonState | Status of the Lon node |
| 4302 LonWorks | 802 | LonBios | Versione bios del modulo espansione LonWorks |
| 3004 Expansion POL925 - IO | - | Input 1 X4 - DIPOL687 | ExFlow option input 1 status |
| 3004 Expansion POL925 - IO | - | Input 2 DI1 - DIPOL926 (1) | ExFlow option input 2 status |
| 3004 Expansion POL925 - IO | - | Input 3 DI2 - DIPOL926 (1) | ExFlow option input 3 status |
| 3004 Expansion POL925 - IO | - | Input 4 DI3 - DIPOL926 (1) | ExFlow option input 4 status |
| 3004 Expansion POL925 - IO | - | Input 5 DI4 - DIPOL926 (1) | ExFlow option input 5 status |
| 3004 Expansion POL925 - IO | - | Input 6 DI1 - DIPOL926 (2) | ExFlow option input 6 status |
| 3004 Expansion POL925 - IO | - | Input 7 DI2 - DIPOL926 (2) | ExFlow option input 7 status |
| 3004 Expansion POL925 - IO | - | Input 8 DI3 - DIPOL925 (2) | ExFlow option input 8 status |
| 3004 Expansion POL925 - IO | - | Input 9 DI4 - DIPOL925 (2) | ExFlow option input 9 status |

9 Maintenance

9.1 General description

Maintenance must be done by authorized centres or by qualified personnel.

The maintenance allows to:

- maintain the unit efficiency
- increase the life span of the equipment
- assemble information and data to understand the state of the unit efficiency and avoid possible damages

Before checking, please verify the following:

- the electrical power supply line should be isolated at the beginning
- the unit isolator is open, locked and equipped with the suitable warning
- make sure no tension is present



After turning off the power, wait at least 5 minutes before accessing to the electrical panel or any other electrical component.



Before accessing check with a multimeter that there are no residual stresses.

9.2 Inspections frequency

Perform an inspection every 6 months minimum.

The frequency, however, depends on the use.



In the event of frequent use it is recommended to plan inspections at shorter intervals:

- frequent use (continuous or very intermittent use, near the operating limits, etc)
- critical use (service necessary)

| √ | intervention frequency (months) | 1 | 6 | 12 |
|----|--|---|---|----|
| 1 | presence corrosion | | | X |
| 2 | panel fixing | | | X |
| 3 | fan fixing | | X | |
| 4 | coil cleaning | | X | |
| 5 | bowl cleaning + sanitisation | | X | |
| 6 | outflow test | | X | |
| 7 | air filters cleaning / inspection | X | | |
| 8 | check of the fixing and the insulation of the power lead | | | X |
| 9 | check of the earthing cable | | | X |
| 10 | electric panel cleaning | | | X |
| 11 | capacity contactor status | | | X |
| 12 | terminal closing, cable insulation integrity | | | X |
| 13 | voltage and phase unbalancing (no load and on-load) | | X | |
| 14 | absorptions of the single electrical loads | | X | |
| 15 | test of the compressor crankcase heaters | | X | |
| 16 | Checking for leaks | | | * |
| 17 | survey of the refrigerant circuit operating parameters | | X | |
| 18 | safety valve | | | * |
| 19 | protective device test: pressure switches, thermostats, flow switches etc.. | | X | |
| 20 | control system test: setpoint, climatic compensations, capacity stepping, water / air flow-rate variations | | X | |
| 21 | control device test: alarm signalling, thermometers, probes, pressure gauges etc.. | | X | |

* Refer to the local regulations; and ensure correct adherence. Companies and technicians that effect interventions of installation, maintenance/repairs, leak control and recovery must be CERTIFIED as expected by the local regulations. The leak control must be effected with annual renewal.

9.3 Unit booklet

It's advisable to create a unit booklet to take notes of the unit interventions.

In this way it will be easier to adequately note the various interventions and aid any troubleshooting.

Report on the booklet:

- date
- intervention description
- carried out measures etc.

9.4 Standby mode

If a long period of inactivity is foreseen:

- turn off the power
- avoid the risk of frost (empty the system or add glycol)

Turn off the power to avoid electrical risks or damages by lightning strikes.



With lower temperatures keep heaters turned on in of the electrical panel (option).

It's recommended that the re-start after the stopping period is performed by a qualified technician, especially after seasonal stops or seasonal switching.

When restarting, refer to what is indicated in the "start-up" section.

Schedule technical assistance in advance to avoid hitches and to guarantee that the system can be used when required.

9.5 Outdoor air coil



Contact with the exchanger fins can cause cuts: wear protective gloves to perform the above described operations.

The finned surfaces of the cooling coils and, in particular, the condense collection bowls constitute places where microorganisms and moulds greatly flourish.

It is very important to foresee periodical cleaning with suitable detergents and, eventually, disinfect with sanitising products.

9.6 Condensation collection basin

Dirt or scale can give rise to clogging.

Also, microorganisms and mould can flourish in the bowl.

It is very important to foresee periodical cleaning with suitable detergents and, eventually, disinfect with sanitising products.

Once cleaning is completed, pour water inside the bowl to check the regular outflow.

9.7 G4 Folded air filters

It is very important for the air treatment coil to offer maximum thermal exchange: the unit must always work with clean and installed filters.

Cleaning and replacement of filters are very important from an hygienic-sanitary point of view.



Operation with clogged filters leads to a reduction in the air flow rate with malfunctionings and block, up to possible breaks in the unit.

The frequency with which the filters must be checked depends on the quality of the air, the unit operation hours, the dustiness and crowding of rooms.



Frequency can indicatively vary from WEEKLY to MONTHLY.



It is advised to start with frequent checks, subsequently adjusting frequency to degree of detected dirt.

1. Remove the closing panels
2. Delicately remove the filter avoiding dirtying the area below
3. Wash the filtering jacket in warm water with common detergent
4. Accurately rinse in running water avoiding spilling in the room
5. Dry the filter
6. Insert it back in its seat
7. Remount the closing panels

Old filters, washing wastewater and residues must be disposed of according to the current standards.

9.8 High efficiency air filter

Accessory

For details see:

10 Accessories p. 54

9.9 Water side exchanger

It is very important for the exchanger to be able to provide the maximum thermal exchange, therefore it is essential for the inner surfaces to be clean of dirt and incrustations.

Periodically check the difference between the temperature of the supply water and the condensation temperature: if the difference is greater than 8°C–10°C it is advisable to clean the exchanger.

The clearing must be effected:

- with circulation opposite to the usual one
- with a speed at least 1,5 times higher than the nominal one
- with an appropriate product moderately acid (95% water + 5% phosphoric acid)
- after the cleaning rinse with water to inhibit the action of any residual product

9.10 crankcase heater

Check:

- closure
- Operation

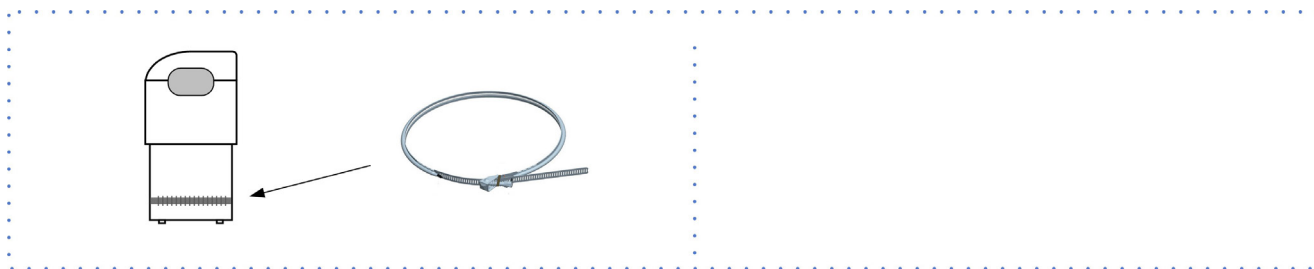

9.11 Copeland scroll compressor

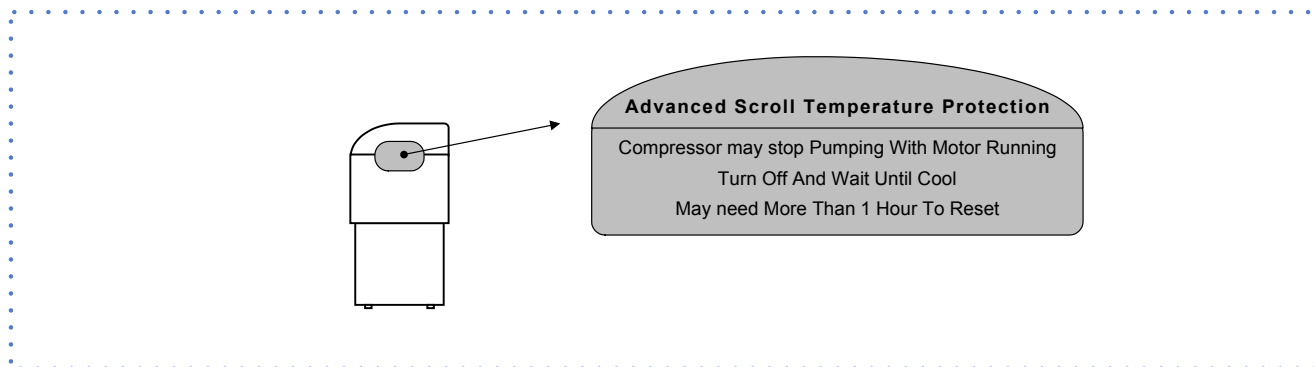

9.12 Electric heaters

Accessory

Check:

- cleaning state
- fastening
- presence of corrosion

9.13 Humidifier

Accessory

For details see:

10 Accessories p. 54

9.14 Supply fan: how to access

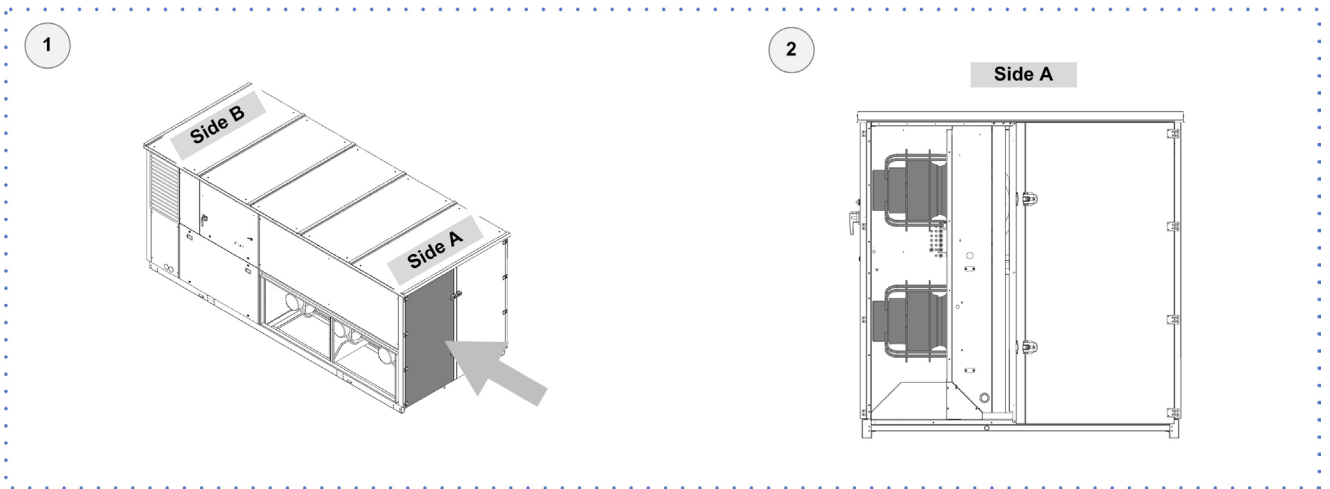

9.15 Exhaust fan: how to access

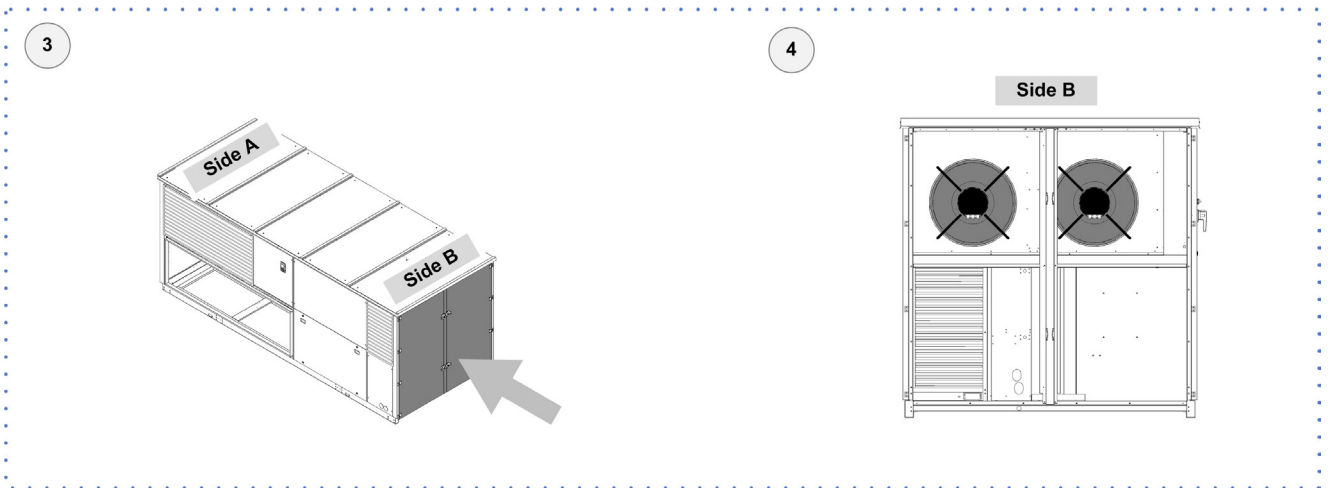

9.16 Water circuit: how to access

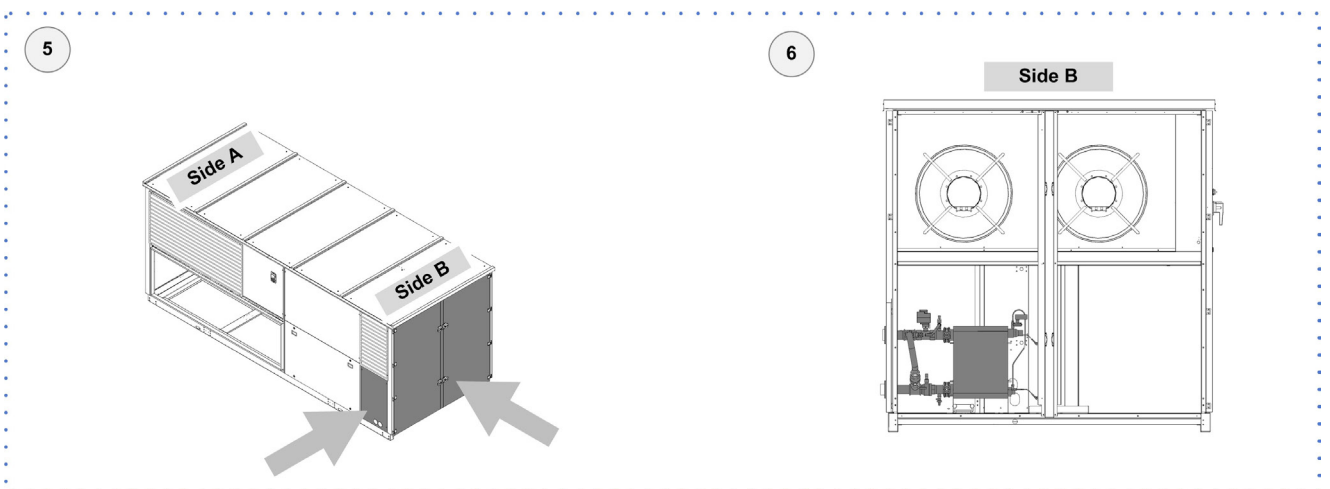

10 Accessories

10.1 Configurations

- CAK Configuration with single fan section for full recirculation
- CBK Configuration with single fan section for recirculation and fresh air
- CCK Configuration with double fan section for recirculation, fresh air, exhaust and Free-Cooling
- CCKP Configuration with double fan section with fresh air, exhaust and THOR thermodynamic recovery

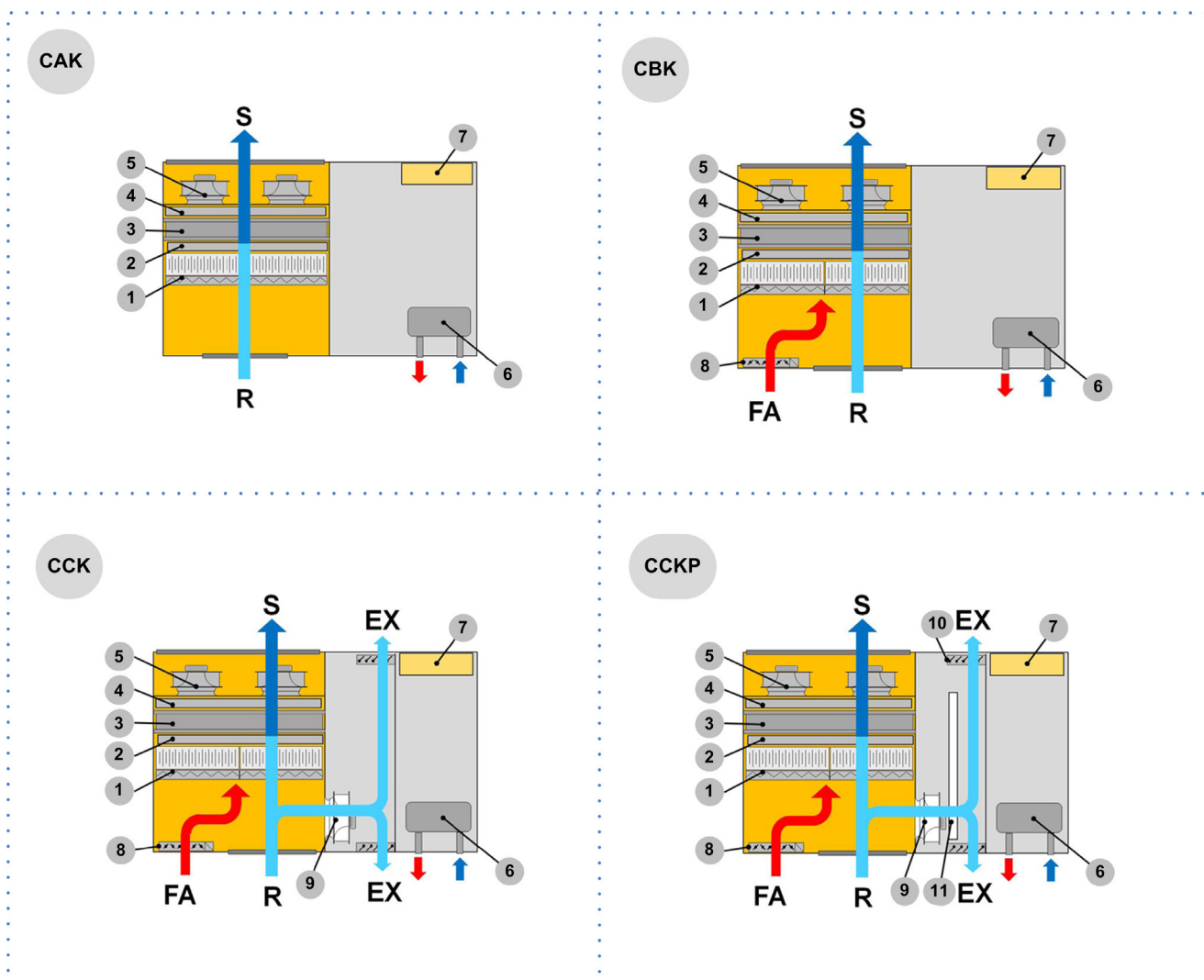

1. G4 efficiency filters + H10 equivalent electronic filters
2. Hot water exchanger or electric heaters
3. Handling exchanger
4. Hot gas reheating exchanger
5. Return + supply fan section
6. Source side exchanger

R Return air
S Supply air

7. Electrical panel
8. Renewal air damper
9. Exhaust fan
10. Overpressure damper
11. Thermodynamic recovery exchanger, THOR

FA Fresh air
EX Exhaust air

10.2 Hydraulic pipework arrangement for loop with constant flow-rate

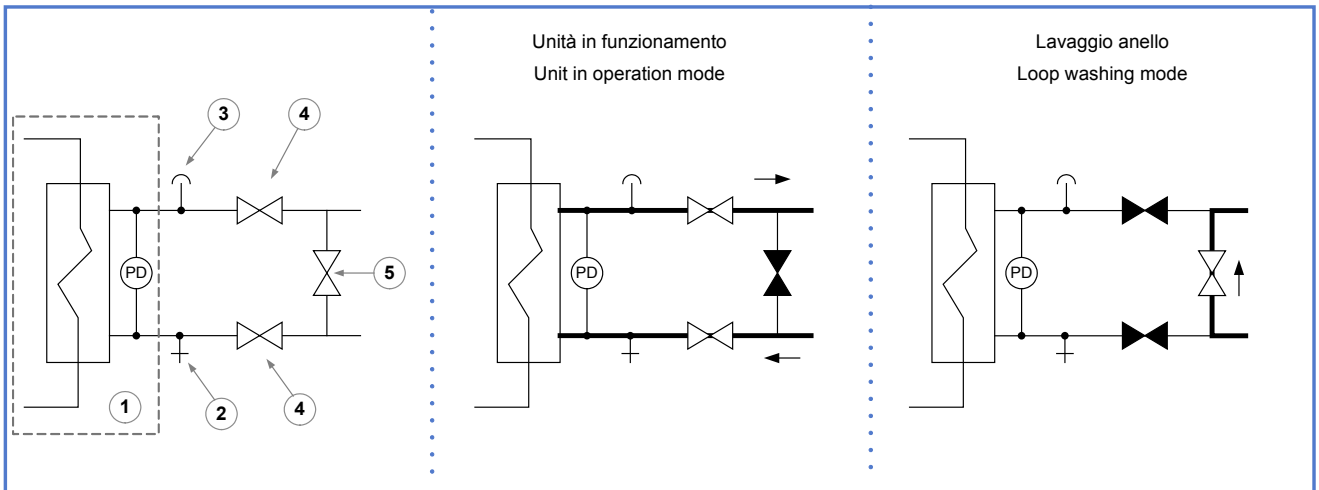

1. plate heat exchanger complete with water side differential pressure switch
2. drainage valve
3. vent valve
4. two-way manually activated valves
5. manually activated two-way valve for loop wash by-pass

10.3 Hydraulic pipework arrangement for loop with variable flow-rate

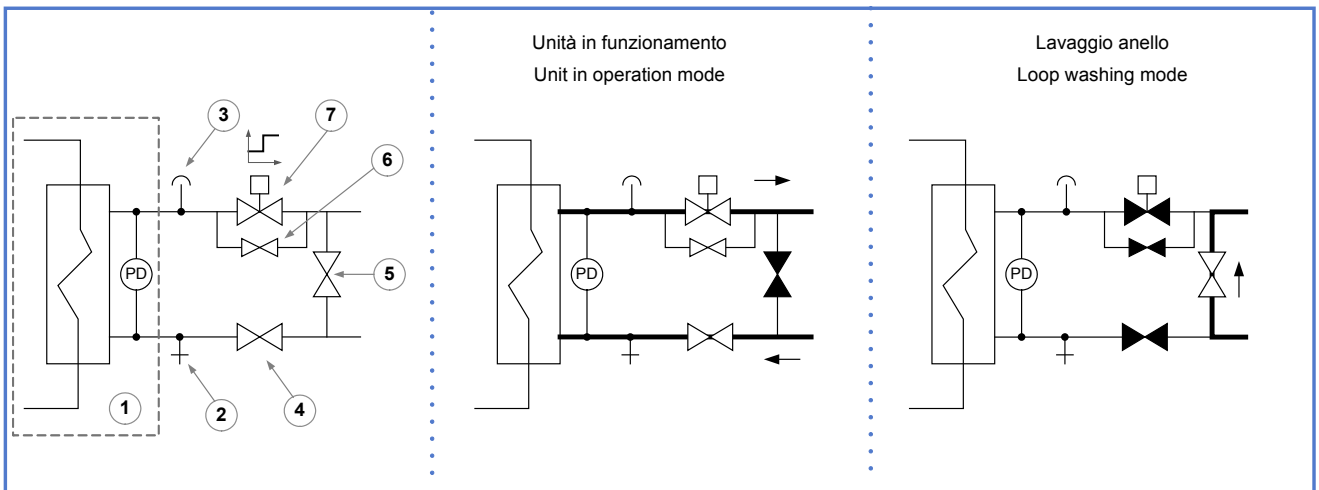

1. plate heat exchanger complete with water side differential pressure switch
2. drainage valve
3. vent valve
4. two-way manually activated valves
5. manually activated two-way valve for loop wash by-pass
6. anti-freeze by-pass with manual shut-off valve
7. two-way motorize ON/OFF valve

10.4 Hydraulic pipework arrangement for system with disposable water

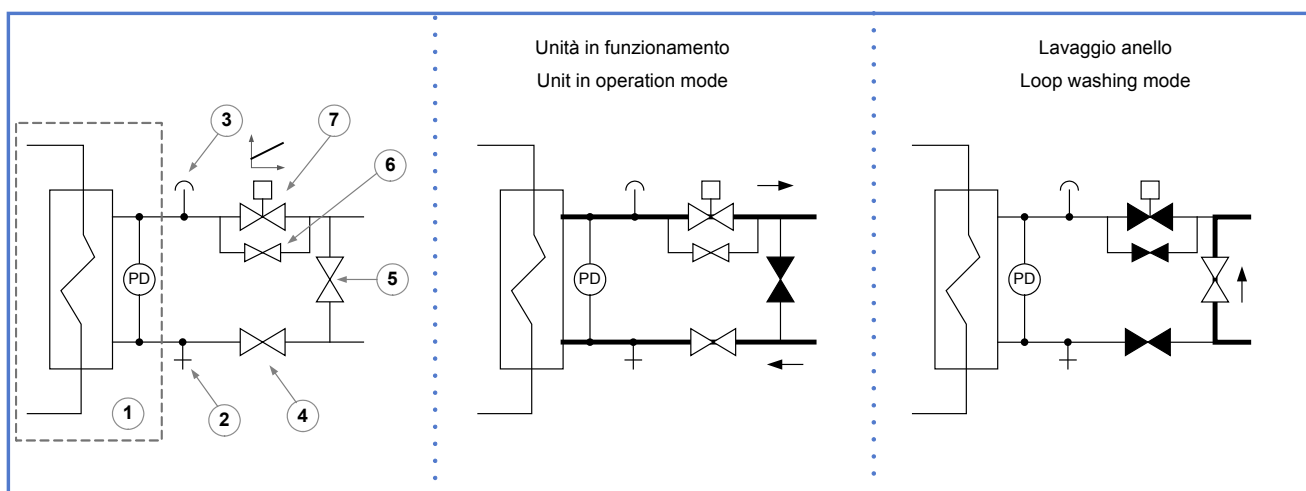

1. plate heat exchanger complete with water side differential pressure switch
2. drainage valve
3. vent valve
4. two-way manually activated valves
5. manually activated two-way valve for loop wash by-pass
6. anti-freeze by-pass with manual shut-off valve
7. two-way modulating motorized valve

10.5 Heater humidifier

Start-up

Check the water supply pressure is not higher than 3 bar.

Open the flow rate measuring device/regulator and adjust it on 50% of the value in the table.

Wait 10/15 minutes so the heater soaks and starts.

Adjust the water flow rate by choosing whether to give greater importance to comfort or containment of the water consumption.

With an EXCESSIVE flow rate, it is possible for the water to flow in the channels or overflow from the bowl.

With INSUFFICIENT flow rate there is no humidifier action.

The heater is correctly wet if a veil of water shows on the external surface (with fan still).

Maintenance

The duration in time and absence of faults require constant cleaning which periodicity depends on different factors:

concentration of dust in the air, water hardness, type of operation, etc..

When cleaning comply with the following prescriptions:

1. Close the water shut-off shutter
2. Remove the evaporating heater
3. Remove the casing panel corresponding to the humidifier
4. Remove the water distributor
5. Remove the evaporating heater
6. Was evaporating heater: the evaporating heater can be washed with water against lime deposits, but must be replaced if the deposits are of limescale type
7. Clean the spraying pipe, found on the alveolar distributor, with metal brush and steel points for the small holes
8. Check the water connection pipe is in good conditions, without holes or cuts that may cause water to leak
9. Wash inside the tank and the various components
10. Remount the evaporating heaters. ATTENTION: The evaporating heaters have a pre-set position to respect the air and water direction, that must be in counter-current. The incorrect position jeopardises the good operation and can cause flowing of the water downstream
11. Upon dehumidifier re-start, check operation again

10.6 Immersed electrode humidifier

SUPPLY WATER

The humidifier must be supplied with mains water having the following features:

- pressure between 0.1 and 0.8 Mpa (1 – 8 bar)
- temperature between 1 and 40°C

Do not use:

- water treated with softeners: it can corrode the electrodes and form foam with possible faults/malfunctionings
- pit, industrial or potentially polluted (chemically or bacteriologically) water
- disinfectants or anti-corrosive substances mixed with water, as potentially irritating

Supplying the humidifier with water treated with reverse osmosis filtering system gives the following advantages:

- reduces limescale deposits
- reduces energy consumptions
- reduces maintenance costs
- increases humidifier duration

Check that the filter guarantees a water flow rate higher than the flow rate of the installed humidifier.

DRAINAGE WATER

It can reach a temperature of 100°C

It contains the same substances of the supply water but in higher concentration.

As it is not toxic, it can be disposed of with white waters.

| Limit values for the supply water with medium-high conductivity in an immersed electrode humidifier | | | |
|---|---------------------------|---------|------|
| | | min | max |
| Hydrogen ions | pH | 7 | 8,5 |
| Specific conductivity at 20°C | µS/cm | 300 | 1250 |
| Total dissolved solids | TDS mg/l | (1) | (1) |
| Dry residue at 180°C | R ₁₈₀ mg/l | (1) | (1) |
| Total hardness | TH mg/l CaCO ₃ | 100 (2) | 400 |
| Temporary hardness | mg/l CaCO ₃ | 60 (3) | 300 |
| Iron + Manganese | mg/l Fe+Mn | 0 | 0,2 |
| Chlorides | ppm Cl | 0 | 30 |
| Silica | mg/l SiO ₂ | 0 | 20 |
| Residual chlorine | mg/l Cl | 0 | 0,2 |
| Calcium sulphate | mg/l CaSO ₄ | 0 | 100 |
| Metallic impurities | mg/l | 0 | 0 |
| Solvents, diluents, soaps, lubricants | mg/l | 0 | 0 |

| Limit values for the supply water with medium-low conductivity in an immersed electrode Humidifier | | | |
|--|---------------------------|--------|-----|
| | | min | max |
| Hydrogen ions | pH | 7 | 8,5 |
| Specific conductivity at 20°C | µS/cm | 125 | 500 |
| Total dissolved solids | TDS mg/l | (1) | (1) |
| Dry residue at 180°C | R ₁₈₀ mg/l | (1) | (1) |
| Total hardness | TH mg/l CaCO ₃ | 50 (2) | 250 |
| Temporary hardness | mg/l CaCO ₃ | 30 (3) | 150 |
| Iron + Manganese | mg/l Fe+Mn | 0 | 0,2 |
| Chlorides | ppm Cl | 0 | 20 |
| Silica | mg/l SiO ₂ | 0 | 20 |
| Residual chlorine | mg/l Cl | 0 | 0,2 |
| Calcium sulphate | mg/l CaSO ₄ | 0 | 60 |
| Metallic impurities | mg/l | 0 | 0 |
| Solvents, diluents, soaps, lubricants | mg/l | 0 | 0 |

(1) Values depending on specific conductivity; in general: TDS \cong 0,95 * σ_{20} ; R₁₈₀ \cong 0,65 * σ_{20}
 (2) not lower than 200% of the chloride content in mg/l of Cl
 (3) not lower than 300% of the chloride content in mg/l of Cl

Periodical checks

Do not use solvents or detergents to clean the plastic components.

For descaling use a vinegar or acetic acid solution at 20%, subsequently rinsing with water.

| | |
|---------|--|
| 15 days | Cylinder: not over 300 hours of work checking operation, general state, no leaks |
| 90 days | Cylinder: not over 1000 hours of work checking operation, general state, no leaks, any replacement |
| 1 year | Cylinder: not over 2500 hours of work (disposable cylinders) Load solenoid valve replacement: disconnect electric power supply, dismantle valve, clean the filter Drain solenoid valve: disconnect electric power supply, remove reel and dismantle valve body and any impurity and rinse The power supply bowl, piping: check they are free and without impurities |
| 5 years | Cylinder: not over 10000 hours of work (inspectional cylinders) replacement |

Humidifier cylinder drainage

Cylinder must be drained in these situations:

- cleaning of the cylinder
- emptying of the cylinder to avoid ice forming
- replacement of the cylinder

The manual drainage is carried out by means of selector SA7: see ELECTRIC CONNECTIONS chapter.

Replacement of the cylinder

To remove the cylinder:

- completely drain the water
- interrupt power supply voltage of humidifier by means of the unit isolator
- remove the vapour pipe from the cylinder
- disconnect the electric connections of the electrodes and remove the pins from the high level electrodes
- loosen the ring nut to remove the pipe unions and the filter (when filter is outside the cylinder)
- lift the cylinder to remove it

Before mounting it:

- the filter body does not require replacing, wash it with water and remount it on the new cylinder, using the new gasket provided with the latter
- check the seal gasket between the cylinder and the drain unit
- remount the cylinder repeating the operations in reverse order

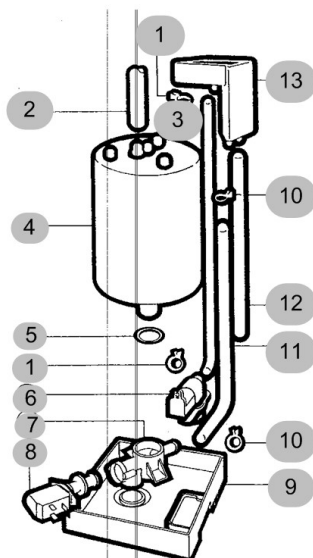

10.7 Electronic filters

The most common contaminants for which the filter is designed, are: air pollution by PM10, PM 2,5 and PM1

Contaminants that can be filtered:

- dry smokes
- powder (up to 0,3 microns)
- smoke electrostatically charged

⊘ Contaminants that can NOT be filtered:

- water vapors also in low concentration
- oil vapors
- large amounts of dust
- metal shavings, iron filing dusts and waste generally
- Gas

⊘ Absolutely to avoid:

- metal dusts also fine
- fumes produced by combustion of organic and not materials (wood, coal, gasoline, etc.)

MATERIALS NECESSARY FOR MAINTENANCE

- Plastic or steel tank (750x750x310 mm) with settling bottom
- Acid detergent B01212 (code CLIVET C6460316)
- Protective gloves and goggles
- Graduated jug
- Pump for manual or pneumatic spraying

⊘ Do not use aluminum tanks or galvanized

Foresee a stainless steel frame that keeps the filters lifted from the tank base to have a settling bottom for the muds.

The electronic adjustment is integrated in the filter; maintenance can be carried out without removing it.

Remove the pre-filter by lifting it of about 1 cm and remove it as shown in figure.

1. Position the filter to be washed on a support to facilitate work.
2. Prepare a tank with a solution of B01212 detergent and water at 1÷20.
3. Immerse the filter in this solution.
4. Ensure the solution covers the entire filter.
5. A slight chemical reaction is noticed within 2÷3 minutes with the development of foam. Wait 3 or 4 minutes.
6. Rinse the filter with a jet of water or using a low-pressure water jet machine.
7. Leave the electrostatic cells to dry in a hot room or directly in the sun for a few hours. Keep the cells lifted from the ground using two metal or wooden laths.
8. Check the ionisation wires before remounting the filter.

The cleaner can be used to clean about 20 filters.

Can be recovered and placed in plastic containers closed; the air oxidizes the cleaner and reduces its effectiveness.

IONISATION WIRES

The impurities can determine oxidation or scaling on the wires, which can be removed using a cloth soaked in alcohol or an abrasive scourer with very fine grain.

Due to the high voltage powering them, the ionisation wires are subject to wear.

To foresee a yearly replacement OF ALL WIRES avoids unexpected breaks.

In case of break:

1. remove all wire pieces present in the cell and remove the springs stretching the wire
2. hook the spring to the wire eyelet
3. grip the ionisation wire with curved beaks pliers
4. hook the top of the spring with the open eyelet to the wire stretcher rod of the electrostatic cell
5. keeping the ionisation wire stretched, with the other hand hook it to the other wire stretching rod, always by means of the curved beaks pliers

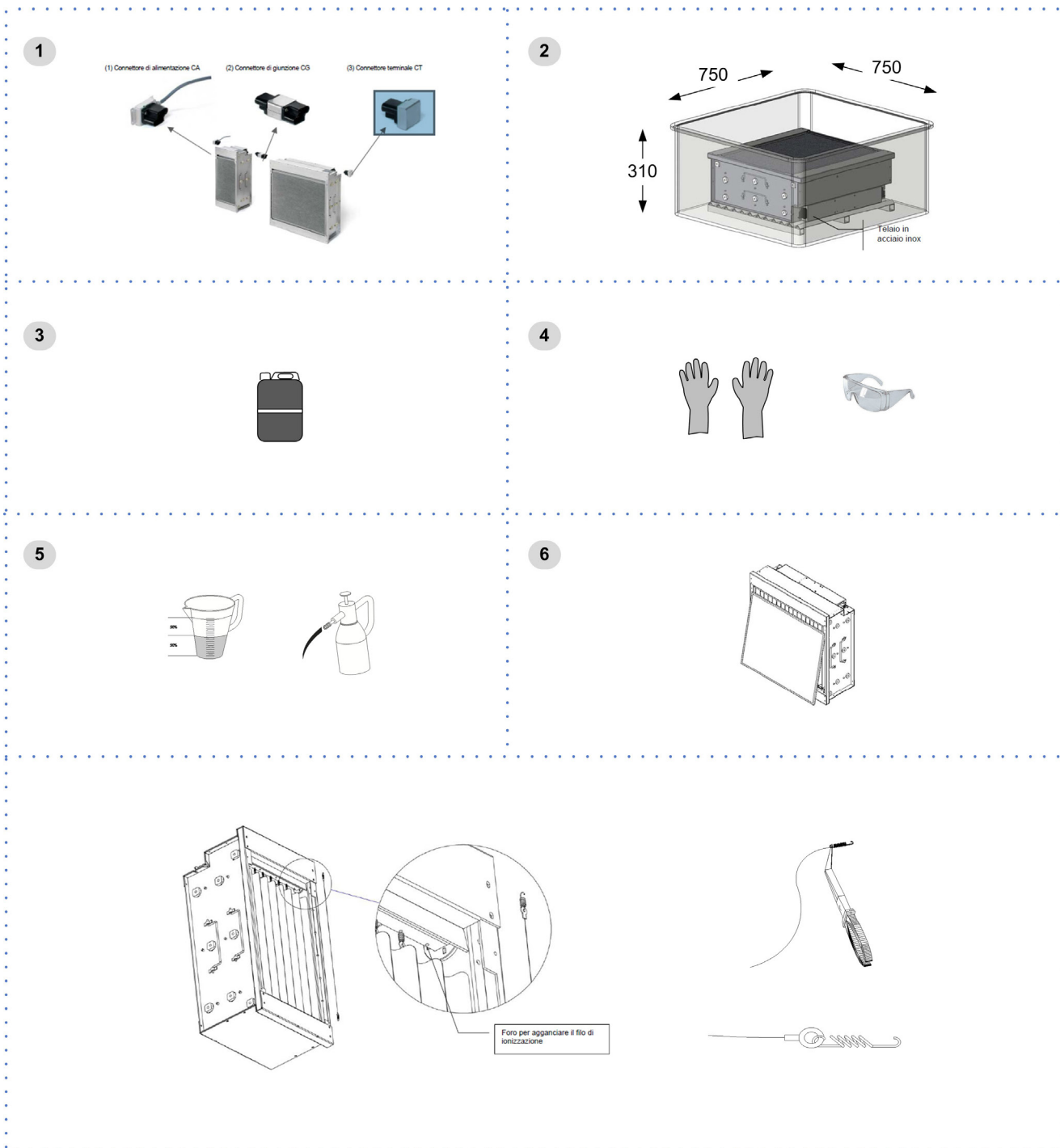

10.8 F7 Highly efficient filters

Accessory

The pocket filters are not renewable, once dirty they must be replaced

1. Open the access panel
2. Delicately remove the filter avoiding dirtying the area below
3. Insert the new filters
4. Close the panel
5. Dispose of the old filters sending them to specialised recycling or collection centres (keep to the standards in force)

11 Decommissioning

11.1 Disconnecting

Only authorised personnel must disconnect the unit.

Avoid leak or spills into the environment.

Before disconnecting the unit, the following must be recovered, if present:

- refrigerant gas
- anti-freeze solutions in the water circuit

Awaiting dismantling and disposal, the unit can also be stored outdoors, if the electrical, cooling and water circuits of the unit have 100% integrity and are isolated, bad weather and rapid change in temperature will not result in any environmental impact.

11.2 Dismantling and disposal

The unit must always be sent to authorised centres for dismantling and disposal.

When dismantling the unit, the fan, the motor and the coil, if operating, may be recovered by the specialist centres for reuse.

All the materials must be recovered or disposed of in compliance with the corresponding national standards in force.

For further information on the decommissioning of the unit, contact the manufacturer.

11.3 Directive EC RAEE

The manufacturer is registered on the EEE National Register, in compliance with implementation of Directive 2012/19/EU and relevant national regulations on waste electrical and electronic equipment.

This Directive requires electrical and electronic equipment to be disposed of properly.

Equipment bearing the crossed-out wheelee bin mark must be disposed of separately at the end of its life cycle to prevent damage to human health and to the environment.

Electrical and electronic equipment must be disposed of together with all of its parts.

To dispose of "household" electrical and electronic equipment, the manufacturer recommends you contact an authorised dealer or an authorised ecological area.

"Professional" electrical and electronic equipment must be disposed of by authorised personnel through established waste disposal authorities around the country.

In this regard, here is the definition of household WEEE and professional WEEE:

WEEE from private households: WEEE originating from private households and WEEE which comes from commercial, industrial, institutional and other sources which, because of its nature and quantity, is similar to that from private households. Subject to the nature and quantity, where the waste from EEE was likely to have been by both a private household and users of other than private households, it will be classed as private household WEEE;

Professional WEEE: all WEEE which comes from users other than private households.

This equipment may contain:

refrigerant gas, the entire contents of which must be recovered in suitable containers by specialised personnel with the necessary qualifications;

- lubrication oil contained in compressors and in the cooling circuit to be collected;
- mixtures with antifreeze in the water circuit, the contents of which are to be collected;
- mechanical and electrical parts to be separated and disposed of as authorised.

When machine components to be replaced for maintenance purposes are removed or when the entire unit reaches the end of its life and needs to be removed from the installation, waste should be separated by its nature and disposed of by authorised personnel at existing collection centres.



12 Residual risks

General description

In this section the most common situations are indicated, as these cannot be controlled by the manufacturer and could be a source of risk situations for people or things.

Danger zone

This is an area in which only an authorised operator may work.

The danger zone is the area inside the unit which is accessible only with the deliberate removal of protections or parts thereof.

Handling

The handling operations, if implemented without all of the protection necessary and without due caution, may cause the drop or the tipping of the unit with the consequent damage, even serious, to persons, things or the unit itself.

Handle the unit following the instructions provided in the present manual regarding the packaging and in compliance with the local regulations in force. Should the refrigerant leak please refer to the refrigerant "Safety sheet".

Installation

The incorrect installation of the unit could cause water leaks, condensate accumulation, leaking of the refrigerant, electric shock, poor operation or damage to the unit itself.

Check that the installation has been implemented by qualified technical personnel only and that the instructions contained in the present manual and the local regulations in force have been adhered to.

The installation of the unit in a place where even infrequent leaks of inflammable gas and the accumulation of this gas in the area surrounding the area occur could cause explosions or fires.

Carefully check the positioning of the unit.

The installation of the unit in a place unsuited to support its weight and/or guarantee adequate anchorage may result in consequent damage to things, people or the unit itself.

Carefully check the positioning and the anchoring of the unit.

Easy access to the unit by children, unauthorised persons or animals may be the source of accidents, some serious.

Install the unit in areas which are only accessible to authorised person and/or provide protection against intrusion into the danger zone.

General risks

Smell of burning, smoke or other signals of serious anomalies may indicate a situation which could cause damage to people, things or the unit itself.

Electrically isolate the unit (yellow-red isolator).

Contact the authorised service centre to identify and resolve the problem at the source of the anomaly.

Accidental contact with exchange batteries, compressors, air delivery tubes or other components may cause injuries and/or burns.

Always wear suitable clothing including protective gloves to work inside the danger zone.

Maintenance and repair operations carried out by non-qualified personnel may cause damage to persons, things or the unit itself.

Always contact the qualified assistance centre.

Failing to close the unit panels or failure to check the correct tightening of all of the panelling fixing screws may cause damage to persons, things or the unit itself.

Periodically check that all of the panels are correctly closed and fixed.

If there is a fire the temperature of the refrigerant could reach values that increase the pressure to beyond the safety valve with the consequent possible projection of the refrigerant itself or explosion of the circuit parts that remain isolated by the closure of the tap.

Do not remain in the vicinity of the safety valve and never leave the refrigerating system taps closed.

Electric parts

An incomplete attachment line to the electric network or with incorrectly sized cables and/or unsuitable protective devices can cause electric shocks, intoxication, damage to the unit or fires.

Carry out all of the work on the electric system referring to the electric layout and the present manual ensuring the use of a system thereto dedicated.

An incorrect fixing of the electric components cover may lead to the entry of dust, water etc inside and may consequently electric shocks, damage to the unit or fires.

Always fix the unit cover properly.

When the metallic mass of the unit is under voltage and is not correctly connected to the earthing system it may be as source of electric shock and electrocution.

Always pay particular attention to the implementation of the earthing system connections.

Contact with parts under voltage accessible inside the unit after the removal of the guards can cause electric shocks, burns and electrocution.

Open and padlock the general isolator prior to removing the guards and signal work in progress with the appropriate sign.

Contact with parts that could be under voltage due to the start up of the unit may cause electric shocks, burns and electrocution.

When voltage is necessary for the circuit open the isolator on the attachment line of the unit itself, padlock it and display the appropriate warning sign.

Moving parts

Contact with the transmissions or with the fan aspiration can cause injuries.

Prior to entering the inside of the unit open the isolator situated on the connection line of the unit itself, padlock and display the appropriate warning sign.

Contact with the fans can cause injury.

Prior to removing the protective grill or the fans, open the isolator on the attachment line of the unit itself, padlock it and display the appropriate warning sign.

Refrigerant

The intervention of the safety valve and the consequent expulsion of the gas refrigerant may cause injuries and intoxication.

Always wear suitable clothing including protective gloves and eyeglasses for operations inside the danger zone.

Should the refrigerant leak please refer to the refrigerant "Safety sheet".

Contact between open flames or heat sources with the refrigerant or the heating of the gas circuit under pressure (e.g. during welding operations) may cause explosions or fires.

Do not place any heat source inside the danger zone.

The maintenance or repair interventions which include welding must be carried out with the system off.

Hydraulic parts

Defects in tubing, the attachments or the removal parts may cause a leak or water projection with the consequent damages to people, things or shortcircuit the unit.

13 Technical information

STANDARD AIRFLOW

General technical data

| Size | | | | 49.4 | 54.4 | 60.4 | 70.4 | 80.4 | 90.4 | 100.4 | 110.4 |
|----------------------------|-----------|---|-----|--------|--------|--------|--------|--------|--------|--------|--------|
| Cooling | | | | | | | | | | | |
| Cooling capacity | CAK | 1 | kW | 175,0 | 187,0 | 215,6 | 255,4 | 283,2 | 338,4 | 366,4 | 392,5 |
| Sensible capacity | | 1 | kW | 123,8 | 133,5 | 142,6 | 162,6 | 186,2 | 239,2 | 258,2 | 277,0 |
| Compressor power input | | 1 | kW | 30,8 | 33,1 | 39,9 | 45,4 | 52,4 | 61,7 | 66,3 | 72,1 |
| EER | | 1 | - | 5,68 | 5,65 | 5,40 | 5,63 | 5,40 | 5,48 | 5,53 | 5,44 |
| SEER | | 9 | | 6,29 | 5,07 | 5,61 | 6,07 | 5,47 | 5,80 | 5,17 | 5,31 |
| ηsc | | 9 | % | 243,7 | 195,0 | 216,6 | 234,9 | 210,7 | 224,0 | 198,9 | 204,5 |
| Water flow-rate | | | l/s | 9,8 | 10,5 | 12,2 | 14,4 | 16,0 | 19,1 | 20,7 | 22,2 |
| Pressure drop water side | | | - | 33,64 | 38,23 | 43,77 | 38,48 | 47,34 | 52,21 | 40,98 | 39,73 |
| Cooling capacity | CBK / CCK | 2 | kW | 183,1 | 195,6 | 225,8 | 267,7 | 296,7 | 354,5 | 383,9 | 411,6 |
| Sensible capacity | | 2 | kW | 127,0 | 136,7 | 146,7 | 167,6 | 191,7 | 246,6 | 266,0 | 284,3 |
| Compressor power input | | 2 | kW | 30,9 | 33,3 | 40,1 | 45,6 | 52,7 | 62,1 | 66,8 | 72,7 |
| EER | | 2 | - | 5,93 | 5,87 | 5,63 | 5,87 | 5,63 | 5,71 | 5,75 | 5,66 |
| Water flow-rate | | | l/s | 10,2 | 10,9 | 12,7 | 14,8 | 16,7 | 19,9 | 21,5 | 23,1 |
| Pressure drop water side | | | - | 36,26 | 41,2 | 47,17 | 41,57 | 51,08 | 56,37 | 44,28 | 42,99 |
| Cooling capacity | CCKP | 3 | kW | 183,1 | 195,6 | 225,8 | 267,7 | 296,7 | 354,5 | 383,9 | 411,6 |
| Sensible capacity | | 3 | kW | 127,0 | 136,7 | 146,7 | 167,6 | 191,7 | 246,6 | 266,0 | 284,3 |
| Compressor power input | | 3 | kW | 30,9 | 33,3 | 40,1 | 45,6 | 52,7 | 62,1 | 66,8 | 72,7 |
| EER | | 3 | - | 5,93 | 5,87 | 5,63 | 5,87 | 5,63 | 5,71 | 5,75 | 5,66 |
| Water flow-rate | | | l/s | 9,3 | 9,9 | 11,5 | 13,7 | 15,2 | 18,1 | 19,6 | 21,1 |
| Pressure drop water side | | | - | 30,14 | 33,96 | 39,36 | 35,04 | 42,58 | 47,15 | 36,98 | 35,94 |
| Heating | | | | | | | | | | | |
| Heating capacity | CAK | 1 | kW | 186,3 | 200,2 | 223,1 | 259,3 | 297,2 | 359,4 | 386,0 | 422,5 |
| Compressor power input | | 1 | kW | 38,0 | 41,0 | 48,1 | 53,2 | 60,5 | 66,8 | 75,0 | 82,6 |
| COP | | 1 | - | 4,90 | 4,88 | 4,64 | 4,87 | 4,91 | 5,38 | 5,15 | 5,12 |
| SCOP | | 9 | | 4,92 | 4,52 | 4,04 | 4,73 | 4,31 | 4,54 | 4,55 | 4,60 |
| ηsh | | 9 | % | 194 | 178 | 159 | 186 | 169 | 179 | 179 | 181 |
| Heating capacity | CBK | 2 | kW | 191,8 | 206,1 | 230,5 | 267,5 | 305,9 | 367,3 | 396,7 | 435,5 |
| Compressor power input | | 2 | kW | 35,2 | 37,9 | 44,5 | 49,2 | 55,9 | 62,5 | 69,3 | 76,2 |
| COP | | 2 | - | 5,45 | 5,44 | 5,18 | 5,44 | 5,47 | 5,88 | 5,72 | 5,72 |
| Heating capacity | CCK | 3 | kW | 191,8 | 206,1 | 230,5 | 267,5 | 305,9 | 367,3 | 396,7 | 435,5 |
| Compressor power input | | 3 | kW | 35,2 | 37,9 | 44,5 | 49,2 | 55,9 | 62,5 | 69,3 | 76,2 |
| COP | | 3 | - | 5,45 | 5,44 | 5,18 | 5,44 | 5,47 | 5,88 | 5,72 | 5,72 |
| Heating capacity | CCKP | 3 | kW | 191,8 | 206,1 | 230,5 | 267,5 | 305,9 | 367,3 | 396,7 | 435,5 |
| Compressor power input | | 3 | kW | 35,2 | 37,9 | 44,5 | 49,2 | 55,9 | 62,5 | 69,3 | 76,2 |
| COP | | 3 | kW | 5,45 | 5,44 | 5,18 | 5,44 | 5,47 | 5,88 | 5,72 | 5,72 |
| Compressor | | | | | | | | | | | |
| Type of compressors | | 4 | | Scroll | Scroll | Scroll | Scroll | Scroll | Scroll | Scroll | Scroll |
| No. of compressors | | | Nr | 4 | 4 | 4 | 4 | 4 | 4 | 4 | 4 |
| Std Capacity control steps | | | Nr | 6 | 6 | 4 | 6 | 6 | 6 | 6 | 6 |
| Refrigerant charge (C1) | CCKP | 5 | Kg | 32 | 32 | 38 | 38 | 42 | 67 | 71 | 73 |
| Refrigerant charge (C2) | | 5 | Kg | 28 | 32 | 38 | 38 | 42 | 67 | 71 | 73 |
| Refrigeration circuits | | | Nr | 2 | 2 | 2 | 2 | 2 | 2 | 2 | 2 |

| Size | | | | 49.4 | 54.4 | 60.4 | 70.4 | 80.4 | 90.4 | 100.4 | 110.4 |
|--|--|---|-------------------|----------|----------|----------|----------|----------|----------|----------|----------|
| Air Handling Section Fans (Supply) | | | | | | | | | | | |
| Type of supply fan | | 6 | | RAD | RAD | RAD | RAD | RAD | RAD | RAD | RAD |
| No. of supply fans | | | Nr | 3 | 3 | 4 | 4 | 4 | 6 | 6 | 6 |
| Fan diameter | | | mm | 560 | 560 | 560 | 560 | 560 | 560 | 560 | 560 |
| Supply airflow | | | l/s | 7222 | 8056 | 9167 | 10278 | 12222 | 14167 | 15556 | 16667 |
| Supply airflow | | | m ³ /h | 26000 | 29000 | 33000 | 37000 | 44000 | 51000 | 56000 | 60000 |
| Installed unit power | | | kW | 2,9 | 2,9 | 2,9 | 2,9 | 2,9 | 2,9 | 2,9 | 2,9 |
| Max. static pressure supply fan | | 7 | Pa | 630 | 540 | 660 | 570 | 360 | 620 | 540 | 460 |
| High static pressure air handling section fans (OPTIONAL) | | | | | | | | | | | |
| Type of supply fan | | | | RAD | RAD | RAD | RAD | RAD | RAD | RAD | RAD |
| Number of supply fans | | | Nr | 3 | 3 | 4 | 4 | 4 | 6 | 6 | 6 |
| Fan diameter | | | mm | 500 | 500 | 500 | 500 | 500 | 500 | 500 | 500 |
| Supply airflow | | | l/s | 7222 | 8056 | 9167 | 10278 | 12222 | 14167 | 15556 | 16667 |
| Supply airflow | | | m ³ /h | 26000 | 29000 | 33000 | 37000 | 44000 | 51000 | 56000 | 60000 |
| Installed unit power | | | kW | 5.5 | 5.5 | 5.5 | 5.5 | 5.5 | 5.5 | 5.5 | 5.5 |
| Max. static pressure supply fan | | 7 | Pa | 1140 | 1080 | 1140 | 1140 | 900 | 1140 | 1140 | 1020 |
| Fans (Exhaust) (only CCK, CCKP-THOR configuration) | | | | | | | | | | | |
| Type of fans | | 6 | | RAD | RAD | RAD | RAD | RAD | RAD | RAD | RAD |
| No. of fans | | 8 | | 2 | 2 | 2 | 2 | 2 | 2 | 2 | 2 |
| Fan diameter | | 8 | mm | 500 | 500 | 630 | 630 | 630 | 630 | 630 | 630 |
| Installed unit power | | 8 | kW | 2,6 | 2,6 | 2,7 | 2,7 | 2,7 | 2,7 | 2,7 | 2,7 |
| Connections | | | | | | | | | | | |
| Condensate drain | | - | mm | 30 | 30 | 30 | 30 | 30 | 30 | 30 | 30 |
| Power supply | | | | | | | | | | | |
| Standard power supply | | - | V | 400/3/50 | 400/3/50 | 400/3/50 | 400/3/50 | 400/3/50 | 400/3/50 | 400/3/50 | 400/3/50 |

The Product is compliant with the Erp (Energy Related Products) European Directive. It includes the Commission delegated Regulation (EU) No 2016/2281, also known as Ecodesign Lot21.

Contains fluorinated greenhouse gases (GWP 2087,5)

Performances in cooling: Indoor air temp. 27°C/19°C W.B. Outdoor air 35°C D.B./24°C W.B. EER referred only to compressors, water entering/leaving temperature 30/35°C

Performance in Heating: Indoor air temp. 20°C D.B./12°C W.B. Outdoor air 7°C/6°C W.B. COP referred only to compressors, water entering/leaving temperature 15/10°C

1. Performance refers to operation at full re-circulation
2. Performance with 30% of outdoor air
3. Performance with 30% of outdoor air including the energy recovery on the exhaust air
4. SCROLL = scroll compressor
5. Indicative values for standard units (CCKP configuration) with possible +/-10% variation. The actual data are indicated on the label of the unit
6. RAD = radial fan electronically controlled
7. Net outside static pressure to win the outlet and intake onboard pressure drops
8. Configuration with double fan section for recirculation, fresh air, exhaust, thermodynamic recovery (CCK) and configuration with double fan section with fresh air and THOR thermodynamic recovery (CCKP)
9. Data calculated in accordance with EN 14825:2018

Sound levels

| Size | Sound power level (dB) | | | | | | | | Sound power level dB(A) | Sound pressure level dB(A) |
|-------|------------------------|-----|-----|-----|------|------|------|------|----------------------------|-------------------------------|
| | Octave band (Hz) | | | | | | | | | |
| | 63 | 125 | 250 | 500 | 1000 | 2000 | 4000 | 8000 | | |
| 49.4 | 74 | 81 | 80 | 82 | 82 | 80 | 77 | 77 | 87 | 67 |
| 54.4 | 76 | 83 | 83 | 84 | 84 | 82 | 79 | 80 | 88 | 69 |
| 60.4 | 74 | 81 | 80 | 82 | 82 | 81 | 78 | 77 | 88 | 67 |
| 70.4 | 76 | 84 | 83 | 85 | 84 | 85 | 79 | 80 | 90 | 70 |
| 80.4 | 78 | 85 | 85 | 86 | 87 | 87 | 82 | 81 | 92 | 72 |
| 90.4 | 76 | 83 | 83 | 85 | 86 | 86 | 81 | 79 | 92 | 71 |
| 100.4 | 78 | 85 | 85 | 87 | 88 | 88 | 82 | 81 | 93 | 73 |
| 110.4 | 80 | 87 | 86 | 88 | 89 | 89 | 84 | 83 | 94 | 74 |

The sound levels are referred to unit operating at full load in nominal conditions. The sound pressure level is referred at a distance of 1 m. from the ducted unit surface operating in free field conditions. External static pressure 50 Pa. (standard UNI EN ISO 9614-2)

Please note that when the unit is installed in conditions different from nominal test conditions (e.g. near walls or obstacles in general), the sound levels may undergo substantial variations.

Operating range (Cooling)

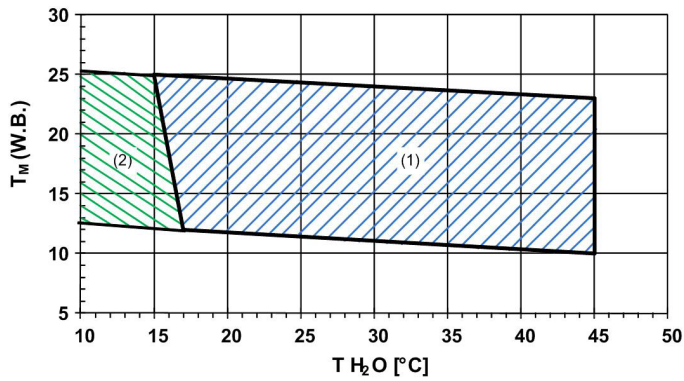

The limits are meant as an indication and they have been calculated by considering:

- general and non specific sizes,
- standard airflow,
- operating at full load
- non-critical positioning and correct use of the unit,
- difference between inlet / outlet water temperature = 5°C

To verify the operating range of the operating units with percentages of outdoor air, always calculate the T_m mixing temperature at the internal heat exchanger input.

T_m = entering internal exchanger air temperature
Attention! Temperature measured with wet bulb (W.B.=WET BULB)

TH20 = water loop temperature (°C) (plate exchanger input)

1. Standard operating range
2. Unit operating range with pumping unit for installation with disposable water (optional)

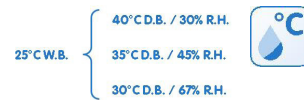

Operating range (Heating)

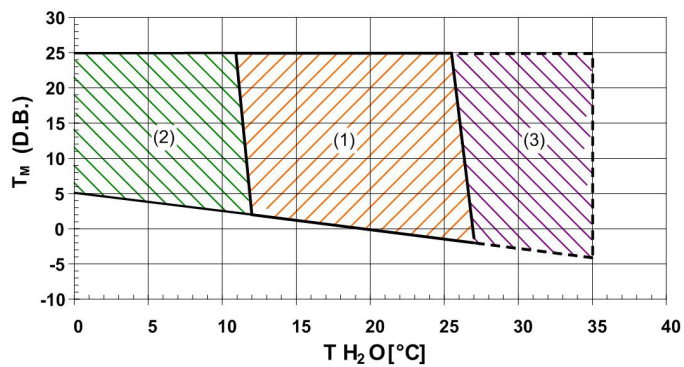

The limits are meant as an indication and they have been calculated by considering:

- general and non specific sizes,
- standard airflow,
- non-critical positioning and correct use of the unit,
- operating at full load
- difference between inlet / outlet water temperature = 5°C

To verify the operating range of the operating units with percentages of outdoor air, always calculate the T_m mixing temperature at the internal heat exchanger input.

T_m = entering internal exchanger air temperature
Attention! Temperature measured with dry bulb (D.B.=DRY BULB)

TH20 = water loop temperature (°C) (plate exchanger input)

1. Operating range at full load
2. Operating range for water glycol system (to prevent frost)
1. + 3. Unit operating range with pumping unit for installation with disposable water (optional) with modulating valve, also for loop high temperatures

Dimensional drawings

Size 49.4 - 54.4 - CAK,CBK, CCK and CCKP configurations

DAA7W49.4_CAK-CBK-CCK-CCKP_1 REV01
DATA/DATE 30/11/2018

Sez. A-A

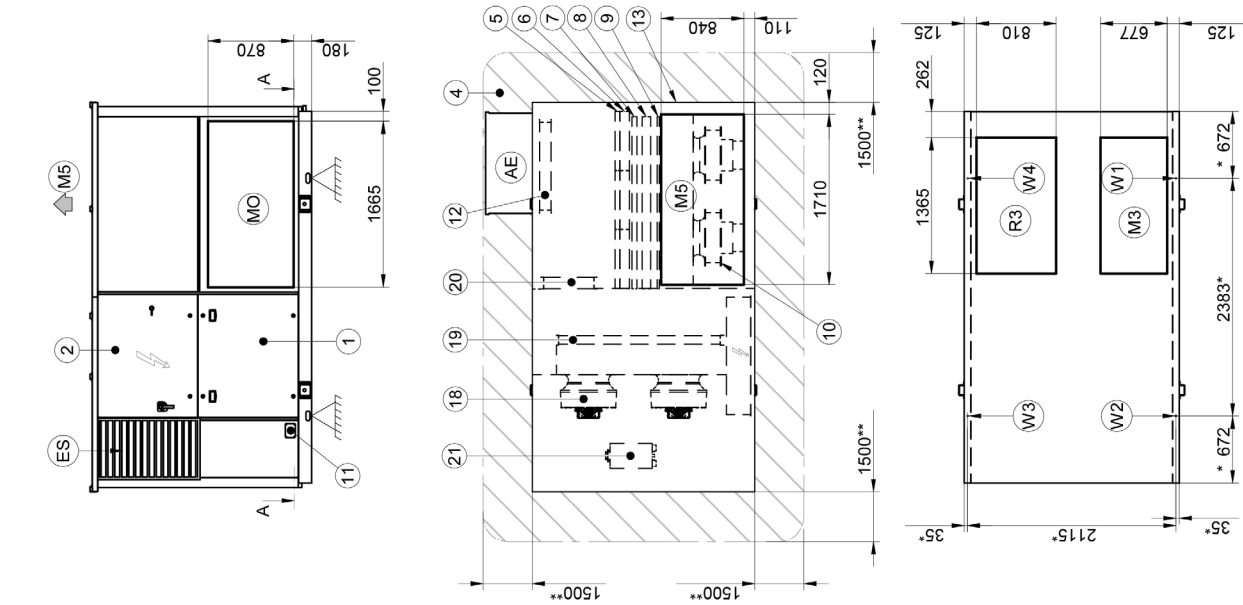

Data:

- 1. Compressor compartment and panel for exchanger inspection
 - 2. Electrical panel
 - 3. Condensate drain
 - 4. Functional clearances
 - 5. G4 air filters (Standard)
 - 6. F7 filters / electrostatic filters (Optional)
 - 7. H2O heating coil / Rec. from food refrigeration/Heating elements (Optional)
 - 8. Air treatment exchanger
 - 9. Re-heating coil (Optional)
 - 10. Electric fan (Supply - return)
 - 11. Power input
 - 12. Outdoor air damper (CBK,CCK and CCKP config.)
 - 13. Access for inspection of coils, filters, heating elements
 - 14. Lifting brackets (removable)
 - 15. Humidifier connections
 - 16. H2O heating coil input Ø 1"1/2" / Input of rec. from food refrigeration coil Ø 2" (Optional)
 - 17. H2O heating coil output Ø 1"1/2" / Output of rec. from food refrigeration coil Ø 2" (Optional)
 - 18. Exhaust electric fan (CCK and CCKP config.)
 - 19. Exhaust air recovery coil (CCKP config.)
 - 20. Exhaust air dampers (CCK and CCKP config.)
 - 21. Plate exchanger
 - 22. Plate exchanger water input 3"
 - 23. Plate exchanger water output 3"
 - 24. Outdoor air return cap, accessory disassembled supplied
- (RO) Horizontal air return
(R3) Floor air return (Optional)
(M0) Horizontal air supply
(M3) Downward airflow (Optional)
(M5) Upward airflow (Optional)
(AE) Outdoor air return (CBK,CCK and CCKP config.)
(ES) Air exhaust (CCK and CCKP config.)
(**) Suggested clearance
(**) Vibration mounts position

| Size | 49.4 | 49.4 | 49.4 | 54.4 | 54.4 | 54.4 |
|----------------------|----------------|------------|-------------|----------------|------------|-------------|
| Configuration | CAK/CBK | CCK | CCKP | CAK/CBK | CCK | CCKP |
| W1 supporting point | kg 561 | kg 588 | kg 612 | kg 648 | kg 675 | kg 698 |
| W2 Supporting point | kg 551 | kg 582 | kg 610 | kg 635 | kg 667 | kg 695 |
| W3 Supporting point | kg 463 | kg 490 | kg 514 | kg 535 | kg 561 | kg 586 |
| W4 Supporting point | kg 484 | kg 507 | kg 527 | kg 558 | kg 581 | kg 601 |
| Operating weight | kg 2080 | kg 2188 | kg 2284 | kg 2397 | kg 2505 | kg 2601 |
| Shipping weight | kg 2059 | kg 2167 | kg 2263 | kg 2376 | kg 2484 | kg 2580 |

The presence of optional accessories may result in a substantial variation of the weights shown in the table.

Size 60.4 - 70.4 - 80.4 CAK,CBK, CCK and CCKP configurations

DAA7W60.4_CAK-CBK-CCK-CCKP_1 REV01
DATA/DATE 21/12/2018

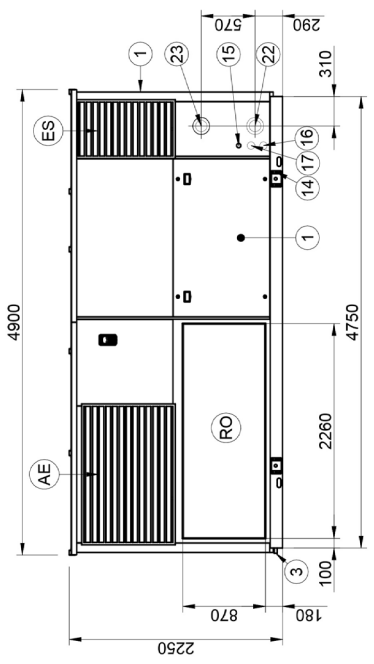
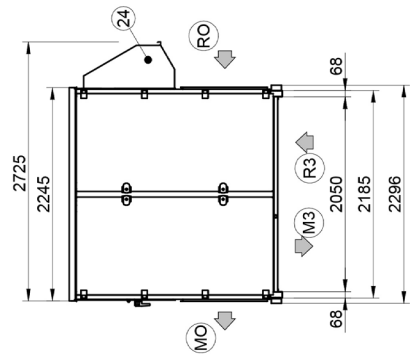
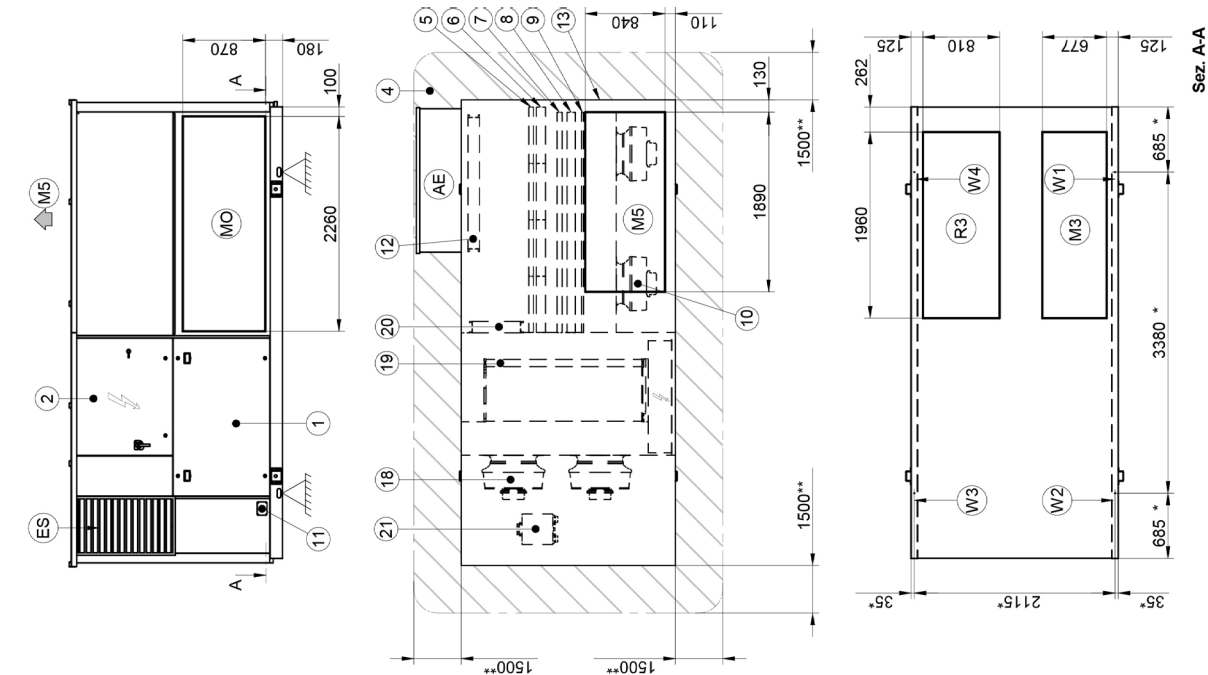

1. Compressor compartment and panel for exchanger inspection
 2. Electrical panel
 3. Condensate drain
 4. Functional clearances
 5. G4 air filters (Standard)
 6. F7 filters / electrostatic filters (Optional)
 7. H2O heating coil / Rec. from food refrigeration/Heating elements (Optional)
 8. Air treatment exchanger
 9. Re-heating coil (Optional)
 10. Electric fan (Supply - return)
 11. Power input
 12. Outdoor air damper (CBK,CCK and CCKP config.)
 13. Access for inspection of coils, filters, heating elements
 14. Lifting brackets (removable)
 15. Humidifier connections
 16. H2O heating coil input Ø 2" / Input of rec. from food refrigeration coil Ø 2" (Optional)
 17. H2O heating coil output Ø 2" / Output of rec. from food refrigeration coil Ø 2" (Optional)
 18. Exhaust electric fan (CCK and CCKP config.)
 19. Exhaust air recovery coil (CCKP config.)
 20. Exhaust air dampers (CCK and CCKP config.)
 21. Plate exchanger
 22. Plate exchanger water input 4"
 23. Plate exchanger water output 4"
 24. Outdoor air return cap, accessory disassembled splitted
- (RO) Horizontal air return
(R3) Floor air return (Optional)
(M0) Horizontal air supply
(M3) Downward airflow (Optional)
(M5) Upward airflow (Optional)
(AE) Outdoor air return (CBK,CCK and CCKP config.)
(ES) Air exhaust (CCK and CCKP config.)
(**) Suggested clearance
(**) Vibration mounts position

| Size | 60.4 | 60.4 | 70.4 | 70.4 | 70.4 | 80.4 | 80.4 | 80.4 |
|----------------------|---------|---------|---------|---------|---------|---------|---------|---------|
| Configuration | CAK/CBK | CCK | CAK/CBK | CCK | CCKP | CAK/CBK | CCK | CCKP |
| W1 supporting point | kg 706 | kg 703 | kg 721 | kg 753 | kg 804 | kg 830 | kg 862 | kg 892 |
| W2 Supporting point | kg 692 | kg 695 | kg 707 | kg 744 | kg 800 | kg 814 | kg 851 | kg 889 |
| W3 Supporting point | kg 583 | kg 585 | kg 595 | kg 627 | kg 674 | kg 685 | kg 717 | kg 749 |
| W4 Supporting point | kg 608 | kg 606 | kg 622 | kg 649 | kg 692 | kg 715 | kg 742 | kg 768 |
| Operating weight | kg 2613 | kg 2613 | kg 2740 | kg 2800 | kg 2997 | kg 3074 | kg 3202 | kg 3328 |
| Shipping weight | kg 2589 | kg 2589 | kg 2716 | kg 2773 | kg 2970 | kg 3044 | kg 3172 | kg 3298 |

The presence of optional accessories may result in a substantial variation of the weights shown in the table.

Size 90.4 - 100.4 - 110.4 - CAK,CBK, CCK and CCKP configurations

DAA7W90.4_CAK-CBK-CCK-CCKP_1 REV01
DATA/DATE 21/12/2018

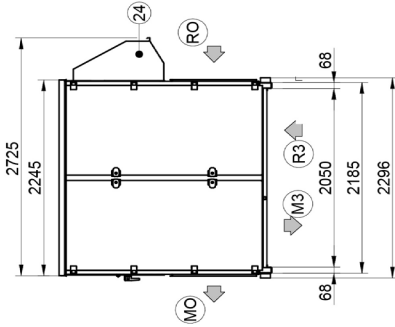
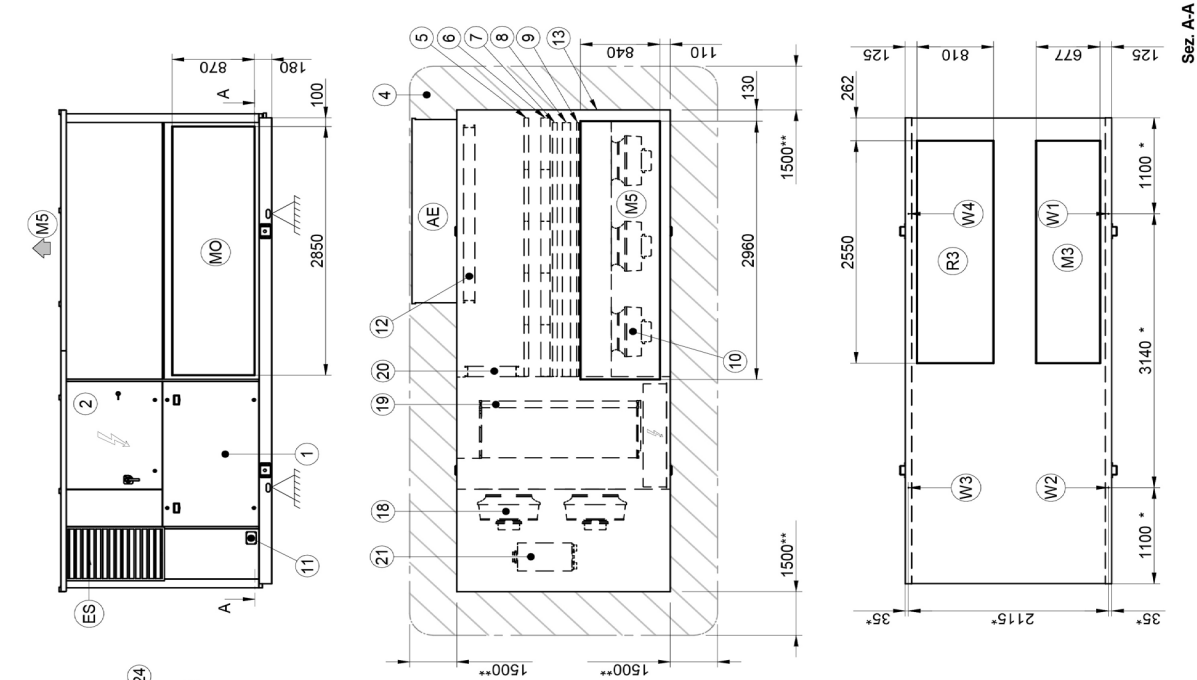

1. Compressor compartment and panel for exchanger inspection
 2. Electrical panel
 3. Condensate drain
 4. Functional clearances
 5. G4 air filters (Standard)
 6. F7 filters / electrostatic filters (Optional)
 7. H2O heating coil / Rec. from food refrigeration/Heating elements (Optional)
 8. Air treatment exchanger
 9. Re-heating coil (Optional)
 10. Electric fan (Supply - return)
 11. Power input
 12. Outdoor air damper (CBK, CCK and CCKP config.)
 13. Access for inspection of coils, filters, heating elements
 14. Lifting brackets (removable)
 15. Humidifier connections
 16. H2O heating coil input Ø 2" / Input of rec. from food refrigeration coil Ø 2" 1/2 (Optional)
 17. H2O heating coil output Ø 2" / Output of rec. from food refrigeration coil Ø 2" 1/2 (Optional)
 18. Exhaust electric fan (CCK and CCKP config.)
 19. Exhaust air recovery coil (CCKP config.)
 20. Exhaust air dampers (CCK and CCKP config.)
 21. Plate exchanger
 22. Plate exchanger water input 4"
 23. Plate exchanger water output 4"
 24. Outdoor air return cap, accessory disassembled supplied
- (R0) Horizontal air return
(R3) Floor air return (Optional)
(M0) Horizontal air supply
(M3) Downward airflow (Optional)
(M5) Upward airflow (Optional)
(AE) Outdoor air return (CBK, CCK and CCKP config.)
(ES) Air exhaust (CCK and CCKP config.)
(**) Suggested clearance
(*) Vibration mounts position

| Size | 90.4 | 90.4 | 100.4 | 100.4 | 100.4 | 100.4 | 110.4 | 110.4 | 110.4 |
|----------------------|------|----------------|------------|----------------|------------|----------------|------------|----------------|------------|
| Configuration | | CAK/CBK | CCK | CAK/CBK | CCK | CAK/CBK | CCK | CAK/CBK | CCK |
| W1 supporting point | kg | 875 | 907 | 946 | 931 | 962 | 951 | 1072 | 1103 |
| W2 Supporting point | kg | 859 | 896 | 943 | 913 | 951 | 999 | 1052 | 1090 |
| W3 Supporting point | kg | 722 | 754 | 795 | 768 | 801 | 841 | 885 | 918 |
| W4 Supporting point | kg | 754 | 781 | 816 | 803 | 829 | 863 | 924 | 950 |
| Operating weight | kg | 3245 | 3373 | 3535 | 3461 | 3589 | 3751 | 3987 | 4115 |
| Shipping weight | kg | 3210 | 3338 | 3500 | 3415 | 3543 | 3705 | 3933 | 4061 |

The presence of optional accessories may result in a substantial variation of the weights shown in the table.



CLIVET SPA

Via Camp Lonc 25, Z.I. Villapaiera - 32032 Feltre (BL) - Italy
Tel. + 39 0439 3131 - Fax + 39 0439 313300 - info@clivet.it

CLIVET GROUP UK Limited

Units F5&F6 Railway Triangle Ind Est, Walton Road - Portsmouth, Hampshire - PO6 1TG - United Kingdom
Tel. + 44 (0) 1489 572238 - Fax. +44 (0) 2392 381243 - enquiries@clivetgroup.co.uk

CLIVET ESPAÑA S.A.U.

C/ Bac de Roda, 36 - 08019 Barcelona - España
Tel: +34 93 8606248 - Fax +34 93 8855392 - info@clivet.es

Av.Manoteras Nº 38, Oficina C303 - 28050 Madrid - España
Tel. +34 91 6658280 - Fax +34 91 6657806 - info@clivet.es

CLIVET GmbH

Hummelsbütteler Steindamm 84, 22851 Norderstedt - Germany
Tel. + 49 (0) 40 32 59 57-0 - Fax + 49 (0) 40 32 59 57-194 - info.de@clivet.com

CLIVET RUSSIA

Elektrozavodskaya st. 24, office 509 - 107023, Moscow, Russia
Tel. + 74956462009 - Fax + 74956462009 - info.ru@clivet.com

CLIVET MIDEAST FZCO

Dubai Silicon Oasis (DSO), High Bay Complex, Office N. 20, PO BOX 342009, Dubai, UAE
Tel. + 9714 3208499 - Fax + 9714 3208216 - info@clivet.ae

CLIVET AIRCONDITIONING SYSTEMS PRIVATE LIMITED

501/502, Commercial-1, Kohinoor City, Old Premier Compound, Kirol Road, Off L B S Marg, Kurla West - Mumbai 400 070 - India
Tel. +91 22 30930250 - info.in@clivet.com

www.clivet.com
www.clivetlive.com