

Building & Industry

**NOVENCO** 

SCHAKO Group

# NOVENCO<sup>®</sup> centrifugal fans CAL Standard, ATEX and EX



# Product facts

## Product

The Novenco® CAL centrifugal fans are robustly built fans of the medium pressure type for operation in aggressive environments.

## Applications

The CAL fans suit a wide range of purposes; for process air in composting plants and other installations in aggressive environments and in industrial installations with high physical requirements. Versions for installation in ATEX zones and for marine EX applications are also available.

## Range

The range comprises nine installation sizes, all with directly-coupled motors.

## Fan specifications

- **Airflow rates:** 0.3 to 21 m<sup>3</sup>/s or 1,100 to 75,600 m<sup>3</sup>/h
- **Casing thicknesses:** 3 mm for impeller sizes  $\varnothing$ 400 -  $\varnothing$ 500, 4 mm for sizes  $\varnothing$ 630 -  $\varnothing$ 710, 5 mm for sizes  $\varnothing$ 800 -  $\varnothing$ 1000 and 6 mm for sizes  $\varnothing$ 1120 -  $\varnothing$ 1250
- **Fan total efficiency:** Up to 82%
- **Impeller blades:** Backward-curved
- **Impeller diameters:**  $\varnothing$ 400 to  $\varnothing$ 1250
- **Temperature range:** 0 to 70 °C
- **Total pressure:** Up to 8,500 Pa

## Motors

**Balancing:** ISO 2373

**Dimension standard:** IEC-72

**Efficiency classes:** IE1- IE4

**Electrical standard:** IEC-34

**Enclosures:** IP55, IP56 or IP65

**Insulation:** Class F or H

**Mounting:** On support frame connected directly to the impeller shaft on drive side and removable

**Speed control:** Direct or frequency drive

**Structural shape:** B3 for flanges

**Terminal boxes:** Boxes of steel mounted on fan casing

**Voltages:** Between 3x220 V and 3x690 V; f.x. 3x400 V, 50 Hz

Impeller sizes [ $\varnothing$ D, mm]	Fan widths		
	100%	85%	70%
400	132-180		132-180
500			132-180
630	160-225		160-225
710	160-225		160-225
800	160-225	160-280	160-280
900	160-280	160-280	160-280
1000	180-280	180-280	180-280
1120	250-280	250-280	250-315
1250	280	280	280-315

Available motor sizes

## Materials

**Bearing brackets and support frame:**

Heavy steel sections

**Housing:** Heavy sheet steel, steel 37-2 or stainless sheet AISI 316L

**Impeller:** Corten, DOMEX 500 and SAF-2205 steel qualities, AISI 316L at reduced RPMs

**Surface treatment:** Hot-dip galvanised

## Classifications

**ATEX:** Category 2G/D according to EU directive 2014/34/EU

**Calculation software:** AirBox program is certified by TÜV.

**Corrosion categories:** Meets the requirements for operation in medium-level corrosive environments in accordance with DS/EN ISO 12944-2 and category C4.

**Flange standard:** Eurovent 1/2 for inlet

**Marine EX:** Guideline IACS F29/2005 for non-sparking fans

**Marine motor classification:** Refer to AirBox program for available registers

**Sound:** ANSI/AMCA 300-14

**Technical classifications:** DS/ISO 21940-11:2016; DS/ISO 21940-14:2012; EN ISO 5801 2017, installation type D

**Temperature range, standard:**

0 to 70 °C

## Accessories

### Installation

- Anti-vibration mountings
- Counter flange
- Flexible connections (Perl / Maritex)

### Safety

- Copper inlet cone (ATEX and EX)
- Space heater for motor
- Thermal motor protection
- Wire guard

### Service

- Drain plug
- Inspection door

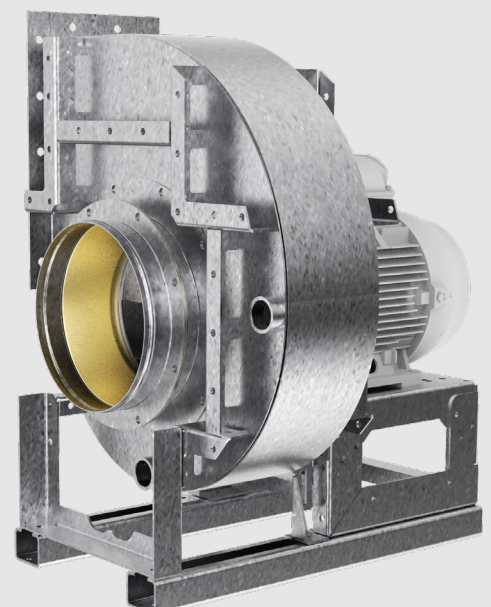

# Description

The Novenco® centrifugal fans type CAL are heavy-duty process-air fans for harsh environments. The output pressure is medium and available throughout the range for a wide field of applications. The universal installation adds flexibility and allows for precise fulfilment of most installation requirements.

## Construction

The fan housing is robustly welded and reinforced with angle stiffeners. A combined motor and bearing bracket is mounted on a support frame on the inlet side of the fan housing.

Stiffeners and brackets are all strong steel sections.

The motor is drive-side removable.

The impeller is mounted directly on the motor shaft and has backward-curved blades.

The shaft bushing in the fan housing is either a simple gap seal with approximately 1 mm gap between shaft and housing, or a double lip seal that prevents aggressive gases and condensate from leaking out. The fan housing has the following features.



Impeller

## FAN HOUSING FEATURES

- A duct boss and conical inlet funnel on the inlet side
- A discharge boss at the lowest point of the fan housing in those installation positions where it is necessary.
- A flange on the outlet side

## Materials and surface treatment

The fan housing and brackets are of heavy sheet steel.

The impeller is available in two stainless versions, either SAF 2205 or AISI 316L for limited RPMs. See "Dimensioning charts" on page 10. The surface is hot-dip galvanised and meets international requirements for operation in medium-level corrosive environments in accordance with DS/EN ISO 12944, part 2.

## Efficiency

The operating economy of the CAL fans is excellent with fan total efficiencies up to 82%, depending on fan size, configuration and motor.

## ATEX and Marine EX fans

The ATEX version complies with the directive 2014/34/EU for equipment installed in explosive atmospheres and environments. The ATEX fans are suited for removal of hot smoke from fires and for service in hazardous gas environments.

The EX version for marine use follows the guidelines in IACS F29/2005 for non-sparking fans. The EX fans are intended for transport of air containing flammable gases.

All ATEX and EX fans are CE-certified and approved in accordance with EN12101-3.



## Airbox calculation program

The AirBox program is Novenco's calculation and configuration tool. Input to the program are requirements for airflow and pressure as well as specific characteristics of the operating environment.

Further requirements for the fan, motor and accessories are also input and form the basis for calculation of possible solutions. Novenco AirBox is free and available on [www.novenco-building.com](http://www.novenco-building.com). It is certified by TÜV Süd in Germany, requires registration and checks automatically for updates.

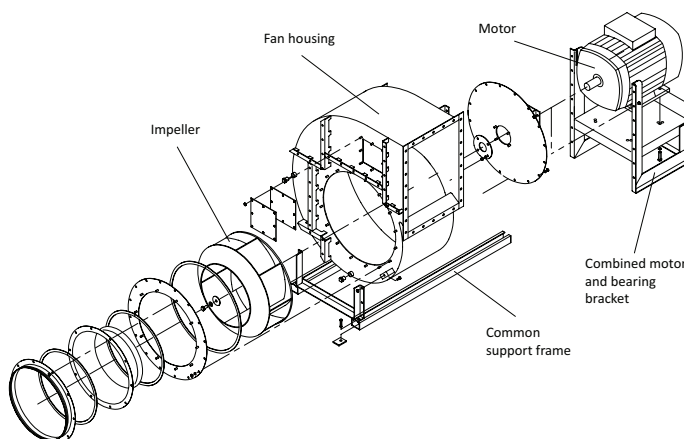

Exploded view of the CAL

# Performance curves

The performance is plotted for each of the three fan widths and for each fan size in which the efficiency is greater than 75%, with an indication of the peak efficiency of 82%.

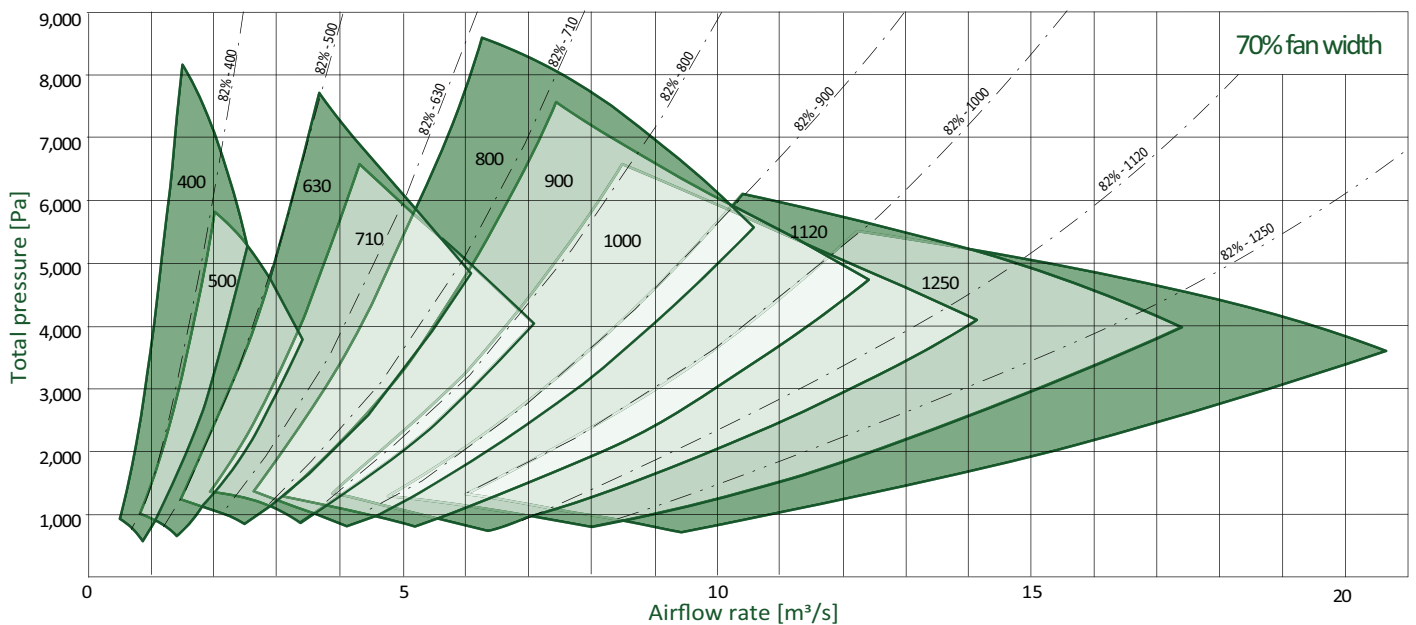
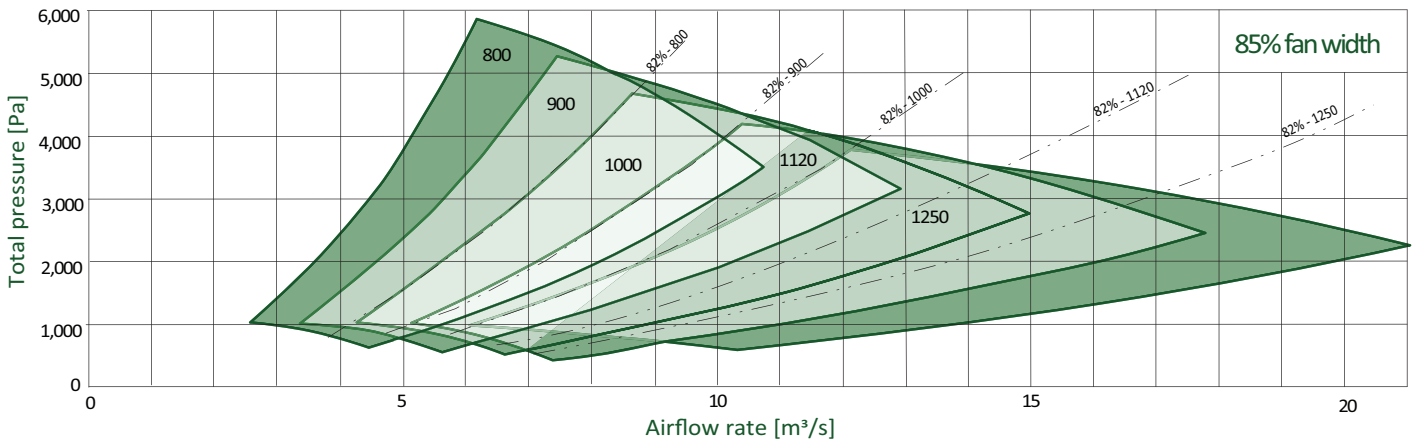
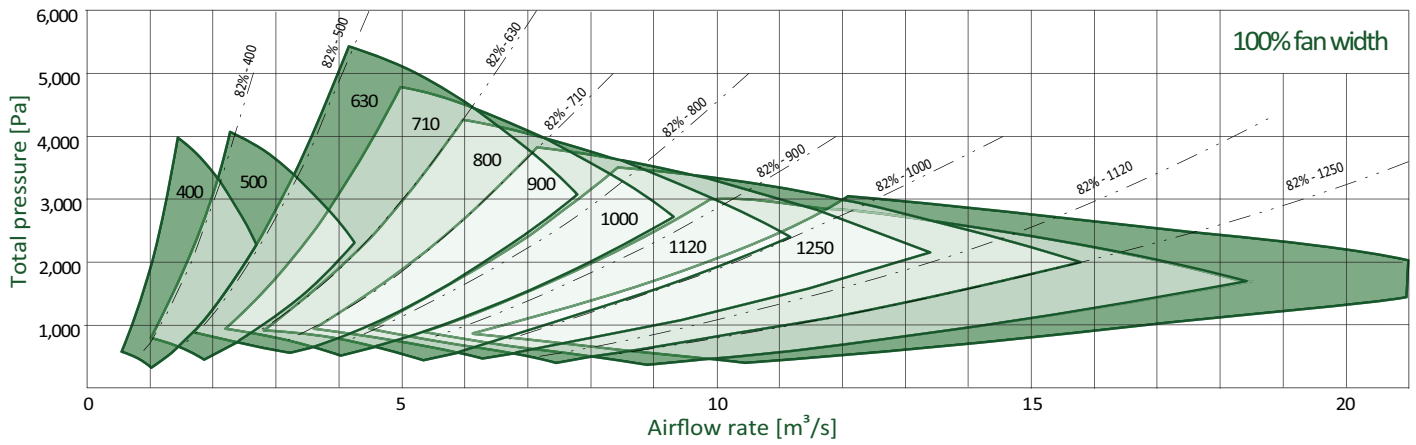

Performance curves

# Dimensions

CAL 100% fan width, motor sizes 132-160-180-200-225-250-280

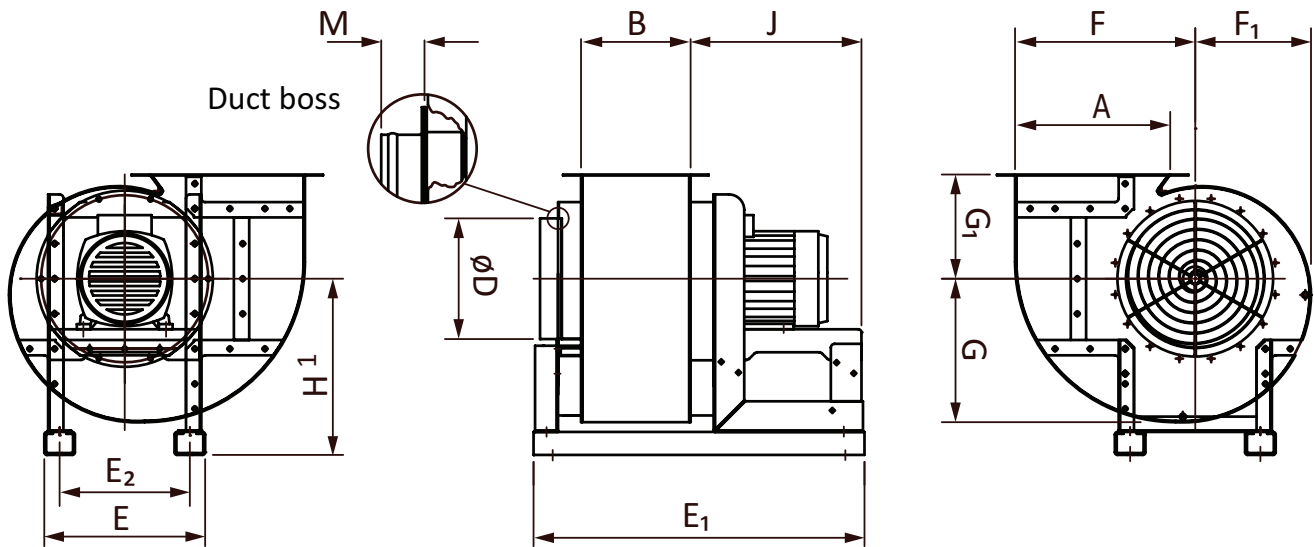

Drain plug is 1½' RG. Measurements are in mm.

	A	B	øD	E	E <sub>1</sub> (as to motor sizes)			E <sub>2</sub>	F	F <sub>1</sub>	G	G <sub>1</sub>	M			
					132-160-180	200-225	250-280						Pos 0	Pos 90	Pos 180	Pos 270
CAL-400	400	286	315	420	864			340	471	302	375	272	55	110	53	53 <sup>7</sup>
CAL-630	630	441	500	644 <sup>3</sup>	1219			564 <sup>4</sup>	737	470	591	429			64	64
CAL-710	710	497	560	708	1095	1275		628	835	536	667	483	64	64	64	53
CAL-800	800	560	630	780	1340			700	936	600	752	544				53
CAL-900	900	630	710	860	1410	1410 <sup>5</sup>	1486	780	1053	670	845	612	66	66	66	
CAL-1000	1000	700	800	925	1480			846	1170	745	939	680	66		66	
CAL-1120	1120	784	900	1016	1795			956	1310	845	1048	762	53			
CAL-1250	1250	875	1000		1907	1907		1060	1463	942	1169	850	55	69	55	55

	H				J								Weights [kg] <sup>2</sup>	
	Pos 0	Pos 90	Pos 180	Pos 270	Motors 132-160-180				Motors 200-225-250-280 <sup>8</sup>					
					Pos 0	Pos 90	Pos 180	Pos 270	Pos 0	Pos 90	Pos 180	Pos 270		
CAL-400	460	460	460	620	446	446	446	446						
CAL-630			510	860							630	630		
CAL-710	770	620	560	960	450					630	630	630		
CAL-800				1060										630
CAL-900	960	770	690		630				650	630 <sup>6</sup>				
CAL-1000	1060		770						630	630				
CAL-1120	1186								850					
CAL-1250	1250	1060		1600					1077	850 <sup>8</sup>			1083	1650

1. Depends on fan position. H is increased by 30-64 mm depending on anti-vibration mountings.
2. Maximum weights exclude motors.
3. For motor size 225 the distance is 664 mm.
4. For motor size 225 the distance is 584 mm.

5. For position RD180 the distance is 1390 mm.
6. For motor size 250 the distance is 795 mm.
7. For position RD270 the distance is 110 mm.
8. Values for motor size 280 are marked separately.

CAL 85% fan width, motor sizes 200-225-250-280

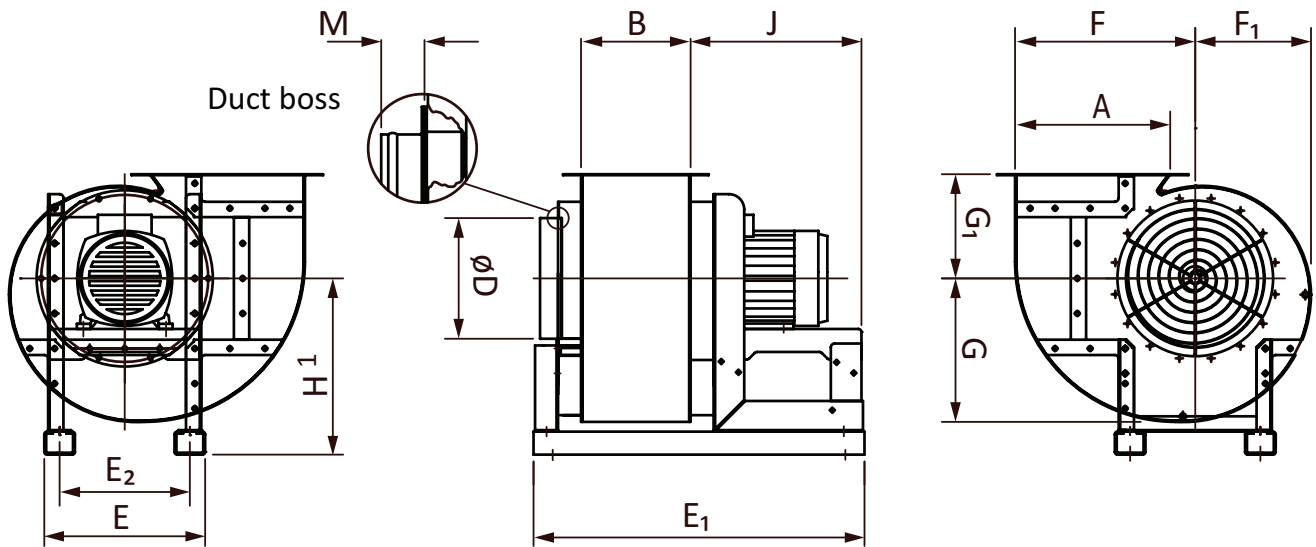

Drain plug is 1½' RG. Measurements are in mm.

	A	B	$\phi D$	E	E <sub>1</sub> (as to motor sizes)		E <sub>2</sub>	F	F <sub>1</sub>	G	G <sub>1</sub>	M			
					200-225	250-280						Pos 0	Pos 90	Pos 180	Pos 270
CAL-800	800	476 <sup>3</sup>	630	780 <sup>4</sup>	1256		700	941 <sup>5</sup>	604 <sup>6</sup>	749 <sup>7</sup>	544		114	114	53
CAL-900	900	536	710	860	1316	1486 <sup>8</sup>	780	1053	670 <sup>9</sup>	845	612		114	120 <sup>10</sup>	114
CAL-1000	1000	595	800	925		1545	846	1170	754 <sup>11</sup>	940	680		126	126	
CAL-1120	1120	667	900	1016		1699	956	1310	845	1048	762		53	53	
CAL-1250	1250	744	1000	1140		1776	1100	1463	942	1169	850	53			

	H				J								Weights [kg] <sup>2</sup>
	Pos 0	Pos 90	Pos 180	Pos 270	Motors 200-225				Motors 250-280				
					Pos 0	Pos 90	Pos 180	Pos 270	Pos 0	Pos 90	Pos 180	Pos 270	
CAL-800		690	620	1060						630	630	630	
CAL-900		770	690	1180		630	630	630		800	800	800	
CAL-1000		860	770							800	800		
CAL-1120		960	860							850	850		
CAL-1250	1300	1060			1077					1077	850		1650

1. H is increased by 30-64 mm depending on anti-vibration mountings.
2. Maximum weights exclude motors.
3. For positions RD180 with motor sizes 200 and 225, and LG270 with motor size 225 the distance is 486 mm.
4. For positions RD180 with motor sizes 200 and RD180 with motor sizes 225 the distance is 760 mm.
5. For position LG270 with motor size 225 the distance is 936 mm.
6. For position LG270 with motor size 225 the distance is 936 mm.

7. For positions RD180 with motor sizes 200 and 225, and LG270 with motor size 225 the distance is 752 mm.
8. For position RD90 with motor size 280 the distance is 1496 mm.
9. For position LG270 with motor sizes 225 and 250 the distance is 675 mm. For position RD180 with motor sizes 225, 250 and 280, and LG180 with motor sizes 225 and 250 the distance is 679 mm.
10. For position RD180 with motor size 225 the distance is 114 mm.
11. For position RD180 with motor size 250 the distance is 745 mm.

CAL 70% fan width, motor sizes 132-160-180-200-225-250-280

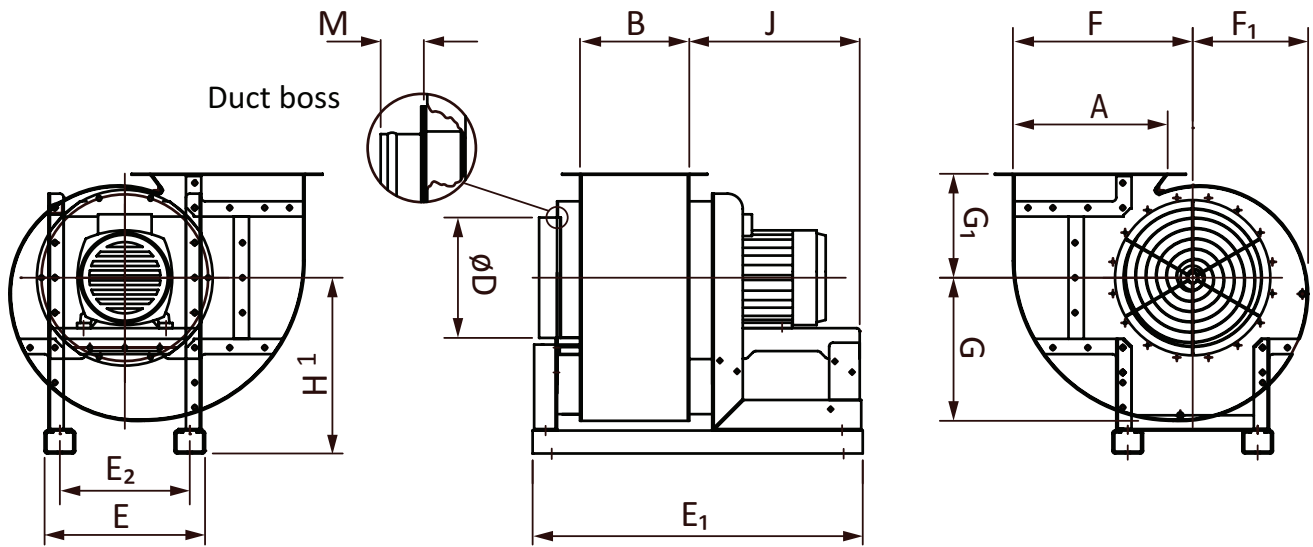

Drain plug is 1½' RG. Measurements are in mm.

	A	B	$\phi D$	E	E <sub>1</sub> (as to motor sizes)			E <sub>2</sub>	F	F <sub>1</sub>	G	G <sub>1</sub>	M (as to fan positions)			
					132-160-180	200-225	250-280						Pos 0	Pos 90	Pos 180	Pos 270
CAL-400	400	202	315	420	780			340	471	302	375	272	55	110	53	53
CAL-500	500	245	400	540	841			460	585	376	470	340	55	53	55	
CAL-630	630	309	500	644	887 <sup>3</sup>	1087	564	737	470	591	429	140	140 <sup>4</sup>	53		
CAL-710	710	348	560	708	1126			628	835	536	665	483	64	53		
CAL-800 <sup>5</sup>	800	486	630	780	1342			700	941	604	749	544	114		53	
CAL-900	900	441	710	860	1440	1391	780	1058	675	845	612	53		174	114	
CAL-1000	1000	490	800	926	1430			846	1175	745	680	640	186		186	
CAL-1120	1120	549	900	1036	1581			996	1310	845	1048	762	53	53		
CAL-1250	1250	613	1000	1140	1645			1060	1463	942	1171	850				

	H (as to fan positions)				J (as to motor sizes and fan positions)								Weights [kg] <sup>2</sup>		
	Pos 0	Pos 90	Pos 180	Pos 270	Motors 132-160-180				Motors 200-225-250-280						
					Pos 0	Pos 90	Pos 180	Pos 270	Pos 0	Pos 90	Pos 180	Pos 270			
CAL-400	460	460	460	620	446	446	446	446							
CAL-500		460	460	770	450	450	450								
CAL-630		560	510	860	450	450	450			630	630				
CAL-710		620	560						630	630					
CAL-800		690		1060					800			630			
CAL-900	960		690	1180				800		800	800				
CAL-1000		860		1310					800		800				
CAL-1120		960	860						850	850					
CAL-1250				1703						856					

1. H is increased by 30-64 mm with anti-vibration mountings.

2. Maximum weights exclude motors.

3. For position RD90 with motor size 160 and position RD180 with motor size 180 the distance is 907 mm.

4. For position RD180 with motor sizes 200 and 225 the distance is 64 mm.

5. For position LG270 with motor size 225 the following values apply: B = 486, E<sub>1</sub> = 1256, F = 936, F<sub>1</sub> = 600 and G = 752.

# Position designations

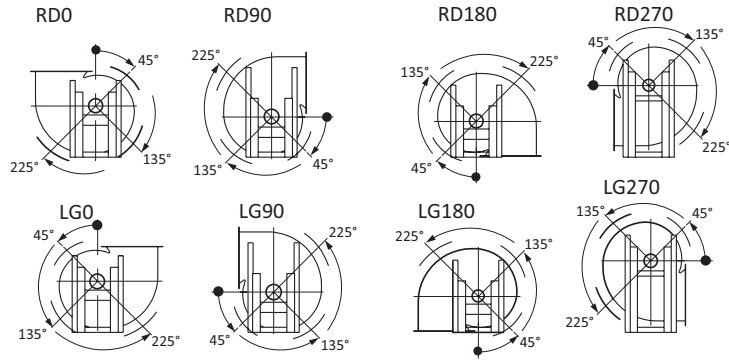

Eurovent position designations from shaft end

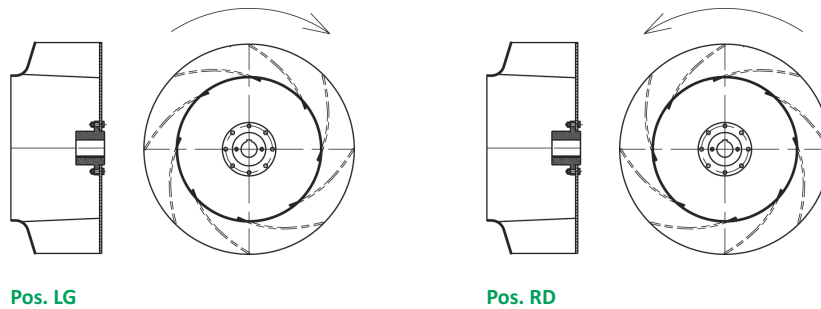

Impeller positions

## Accessories

### Anti-vibration mountings

These are cylindrical rubber discs fitted at the installation points to prevent spreading of vibrations from the fan unit to the surroundings and vice versa.

Anti-vibration mountings are available in three size combinations and depend on fan size and the mounted accessories.

Feet size	Diameter [mm]	Height [mm]
Small	40	40
Medium	50	45
Large	70	45

All fans are supplied with instructions that show the installation positions of the anti-vibration mountings.

### Flexible connections

The inlet and outlet can be fitted with flexible connections of flameproof material for max. 80 °C (Perl E6) or incombustible material for max. 250 °C (Alpha Maritex). Both variants have minimum pressure losses.

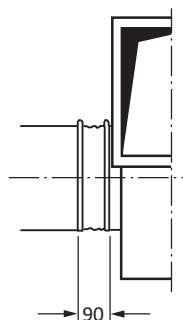

Standard flexible connection for inlet

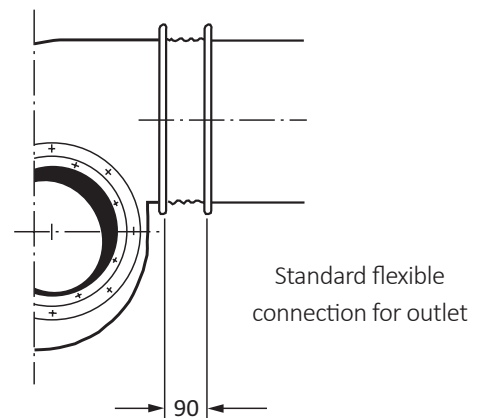

Standard flexible connection for outlet

### Inspection hatch

The hatch is on the side of the fan housing and locked with nuts for easy access. Tightness is ensured with a rubber seal and the pressure loss is minimal.

### Wire guards

Wire guards are available for mounting on the inlet.

### Copper inlet cones

The cones are for ATEX or EX fans and lined with spark-proof copper sheets.

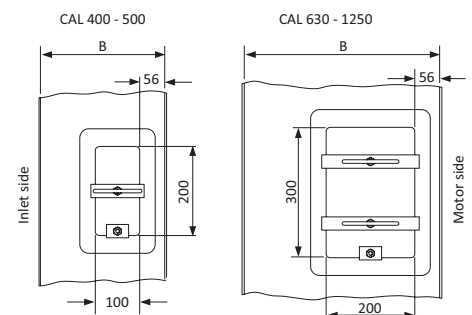

Dimensions of inspection hatches

# Calculation of sizes

The basis for calculations is the airflow rate and the system pressure loss. This is the fan static pressure,  $p_s = p_{s2} - p_{s1}$ .

To find the total fan pressure  $p_t$ , add the air speed pressure, the dynamic pressure  $p_d$  at the outlet and the installation loss at the inlet  $p_1$  and outlet  $p_2$ .

The values are stated in the dimensioning charts on the following pages.

All graphs are plotted for arrangement D.

## Example of motor choice

The power consumption in the dimensioning graphs refers to the fan shaft.

Arrangement B — free inlet and duct for outlet

Airflow rate  $q_v = 1.6 \text{ m}^3/\text{s}$

Pressure loss = static pressure =  $p_s = p_{s2} - p_{s1} = 2000 \text{ Pa}$

The chart on page 10 shows that type CAL-400 is best suited.

### CALCULATION

$p_{s2} - p_{s1}$	=	2000 Pa
+ $p_1$	=	12 Pa
+ $p_d$	=	120 Pa
Total pressure	=	2132 Pa

The chart also shows the following.

Fan speed of 2833 RPM

Efficiency of 81.8%

Power demand of 4.17 kW

Correction  $4.17 \times 1.2 = 5 \text{ kW}$

Choice of motor: 5 kW

### Arrangement A

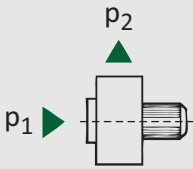

$p_{s2} - p_{s1}$	=	Pa
+ $p_1$	=	Pa
+ $p_d - p_2$	=	Pa
Total pressure	=	Pa

### Arrangement B

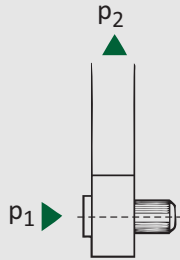

$p_{s2} - p_{s1}$	=	Pa
+ $p_1$	=	Pa
+ $p_d - p_2$	=	Pa
Total pressure	=	Pa

### Arrangement C

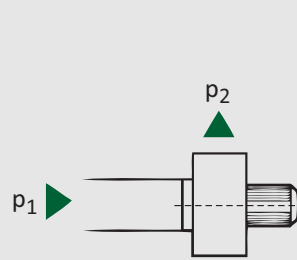

$p_{s2} - p_{s1}$	=	Pa
+ $p_1$	=	Pa
+ $p_d - p_2$	=	Pa
Total pressure	=	Pa

### Arrangement D

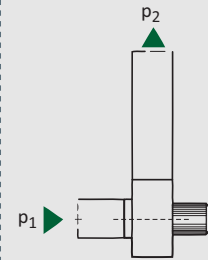

$p_{s2} - p_{s1}$	=	Pa
+ $p_1$	=	Pa
+ $p_d - p_2$	=	Pa
Total pressure	=	Pa

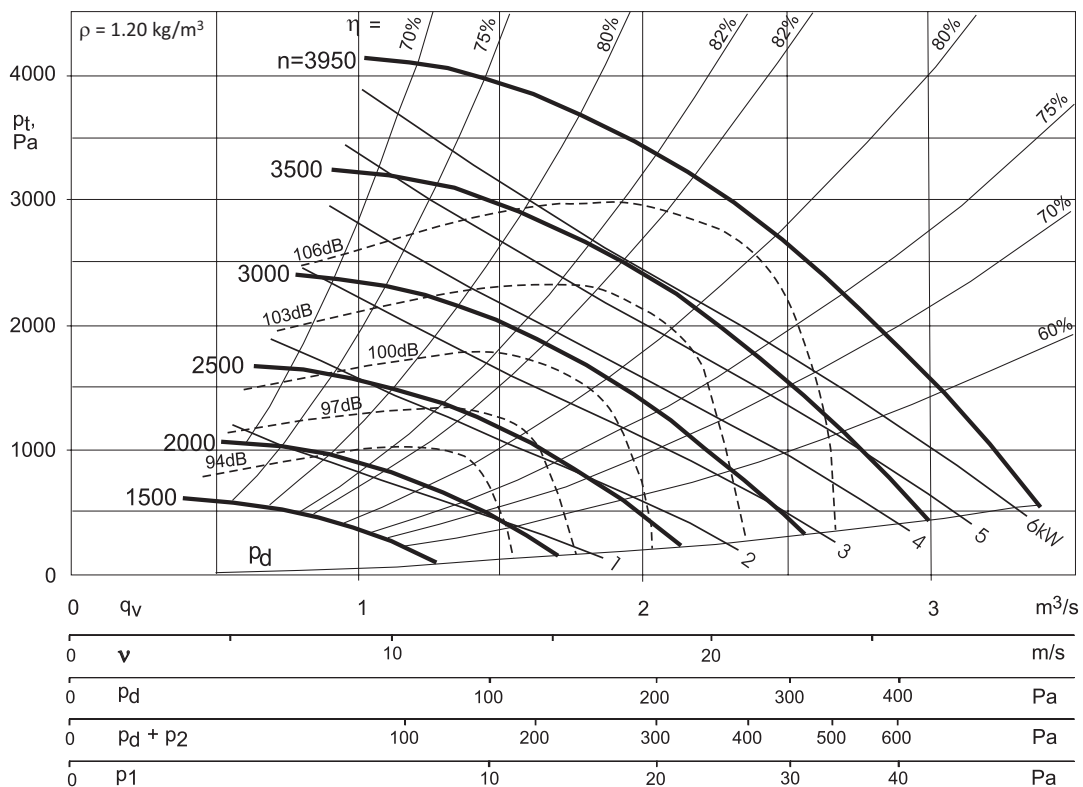

# Dimensioning charts

## CAL 400 - 100%

Moment of inertia:  $I_v = 0.38 \text{ kgm}^2$

Circumferential speed:  $u = 0.021 \times n, \text{ m/s}$

Impeller of DOMEX 500. Max. 3950 RPM

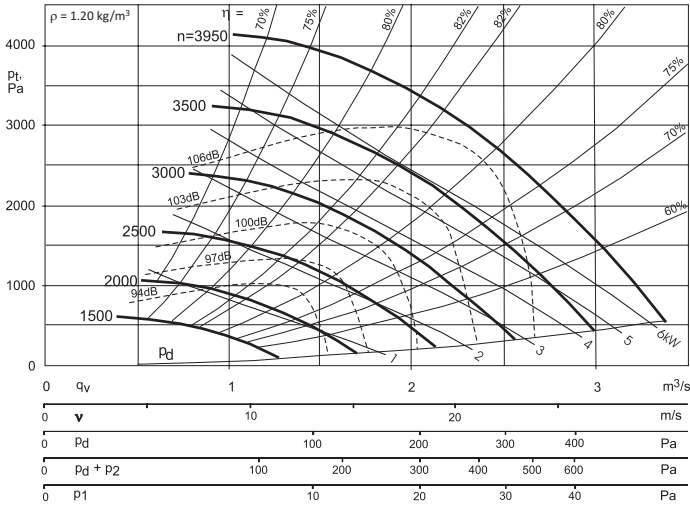

## CAL 500 - 100%

Moment of inertia:  $I_v = 1.17 \text{ kgm}^2$

Circumferential speed:  $u = 0.026 \times n, \text{ m/s}$

Impeller of DOMEX 500. Max. 3190 RPM

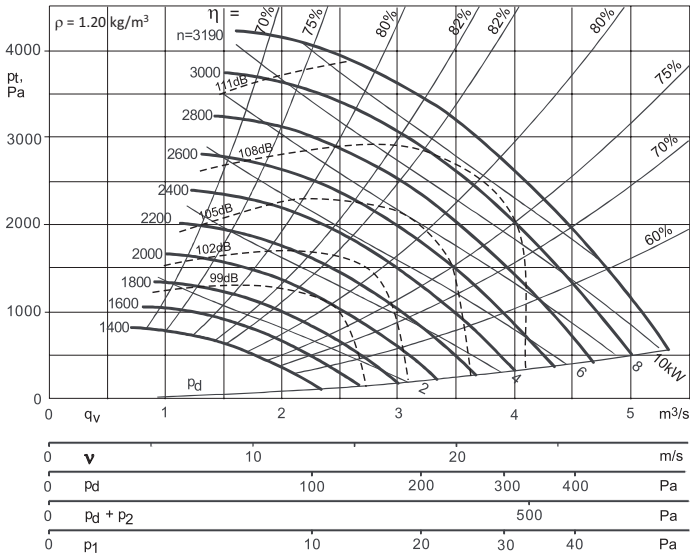

## Basis for chart

(Arr. D)

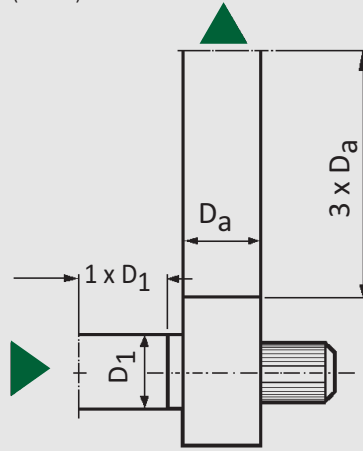

## Symbols

- $p_t$  = total pressure
- $p_d$  = dynamic pressure, outlet
- $p_1$  = connection loss, inlet
- $p_2$  = connection loss, outlet
- $v$  = air speed, outlet
- $q_v$  = volume flow
- $n$  = RPM
- $\eta$  = efficiency in %
- $\text{kW}$  = power demand, impeller
- $\text{dB}$  = sound power level, outlet

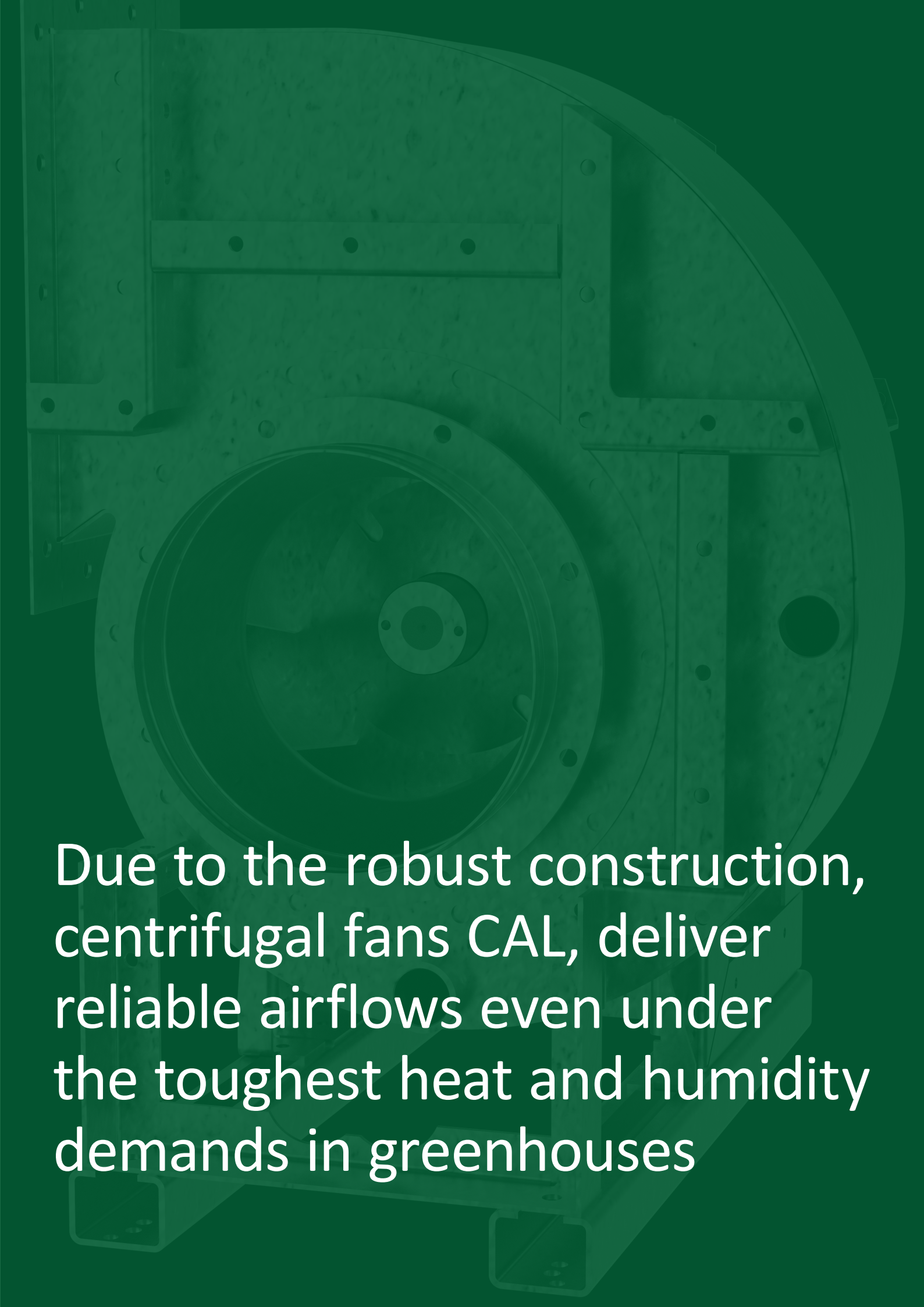

Due to the robust construction, centrifugal fans CAL, deliver reliable airflows even under the toughest heat and humidity demands in greenhouses

### CAL 630 - 100%

Moment of inertia:  $I_v = 3.56 \text{ kgm}^2$

Circumferential speed:  $u = 0.033 \times n, \text{ m/s}$

Impeller of DOMEX 500 or SAF-2205

Max. 2920 RPM

At 45 °C max. 2715 RPM

At 70 °C max 2601 RPM

Impeller of AISI 316L

Max. 1913 RPM

At 45 °C max. 1820 RPM

At 70 °C max. 1751 RPMs

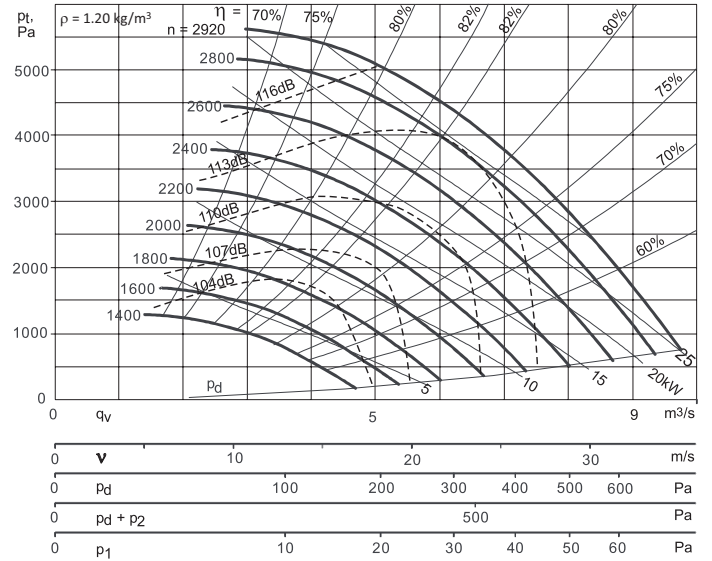

### CAL 710 - 100%

Moment of inertia:  $I_v = 5.76 \text{ kgm}^2$

Circumferential speed:  $u = 0.037 \times n, \text{ m/s}$

Impeller of DOMEX 500 or SAF-2205

Max. 2440 RPM

At 45 °C max. 2270 RPM

At 70 °C max. 2174 RPM

Impeller of AISI 316L

Max. 1599 RPM

At 45 °C max. 1521 RPM

At 70 °C max. 1464 RPM

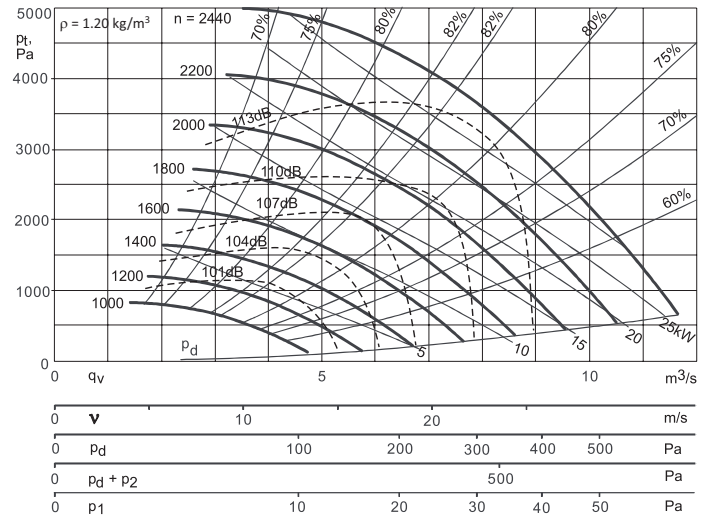

### CAL 800 - 100%

Moment of inertia:  $I_v = 9.31 \text{ kgm}^2$

Circumferential speed:  $u = 0.042 \times n, \text{ m/s}$

Impeller of DOMEX 500 or SAF-2205

Max. 2040 RPM

At 45 °C max. 1898 RPM

At 70 °C max. 1817 RPM

Impeller of AISI 316L

Max. 1337 RPM

At 45 °C max. 1272 RPM

At 70 °C max. 1224 RPM

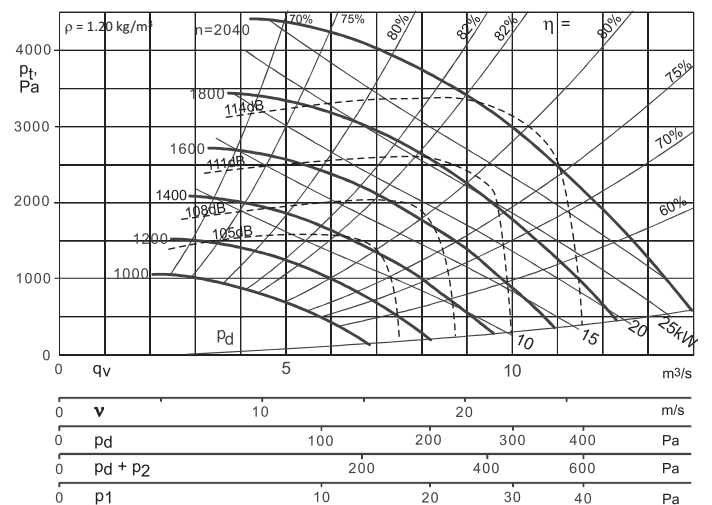

### CAL 900 - 100%

Moment of inertia:  $I_v = 15.0 \text{ kgm}^2$

Circumferential speed:  $u = 0.047 \times n, \text{ m/s}$

Impeller of DOMEX 500 or SAF-2205

Max. 1712 RPM

At 45 °C max. 1590 RPM

At 70 °C max. 1523 RPM

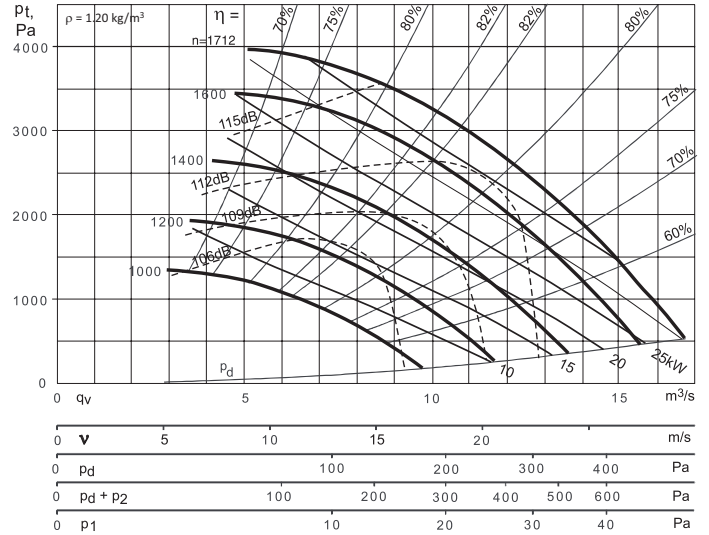

### CAL 1000 - 100%

Moment of inertia:  $I_v = 23.0 \text{ kgm}^2$

Circumferential speed:  $u = 0.052 \times n, \text{ m/s}$

Impeller of DOMEX 500 or SAF-2205

Max. 1461 RPM

At 45 °C max. 1358 RPM

At 70 °C max 1300 RPM

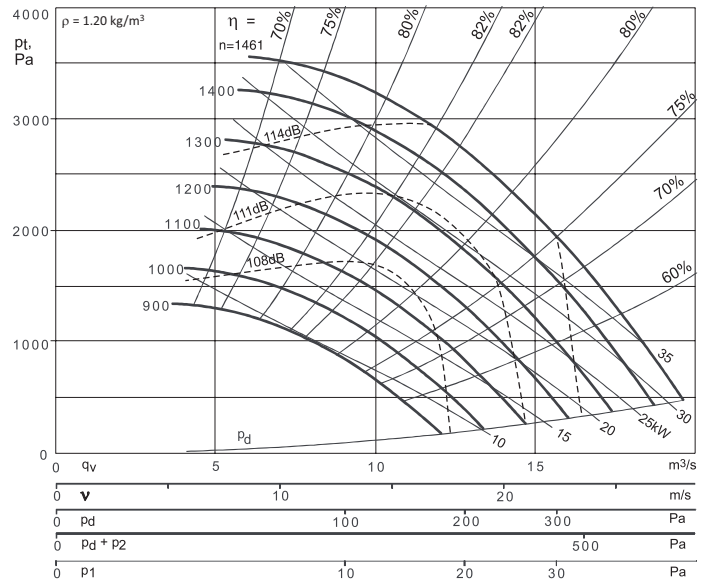

### CAL 1120 - 100%

Moment of inertia:  $I_v = 35.2 \text{ kgm}^2$

Circumferential speed:  $u = 0.059 \times n, \text{ m/s}$

Impeller of DOMEX 500 or SAF-2205

Max. 1233 RPM

At 45 °C max. 1146 RPM

At 70 °C max. 1097 RPM

Impeller of AISI 316L

Max. 957 RPM

At 45 °C max. 910 RPM

At 70 °C max. 876 RPM

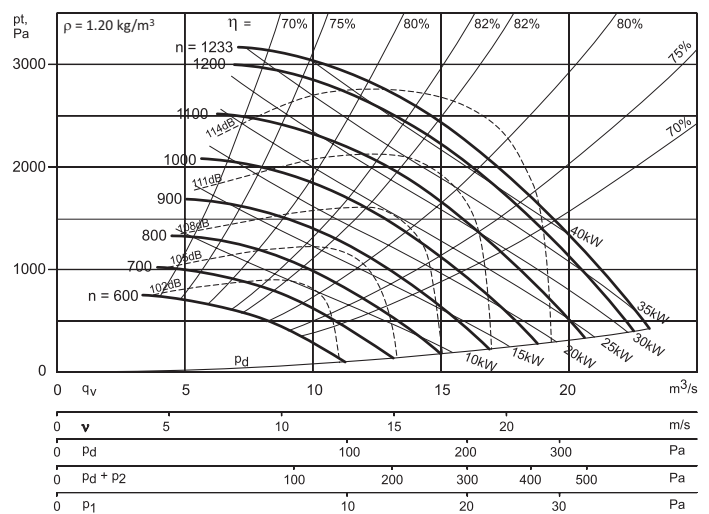

## CAL 1250 - 100%

Moment of inertia:  $I_v = 54.5 \text{ kgm}^2$

Circumferential speed:  $u = 0.065 \times n, \text{ m/s}$

Impeller of DOMEX 500 or SAF-2205

Max. 1046 RPM

At 45 °C max. 972 RPM

At 70 °C max 930 RPM

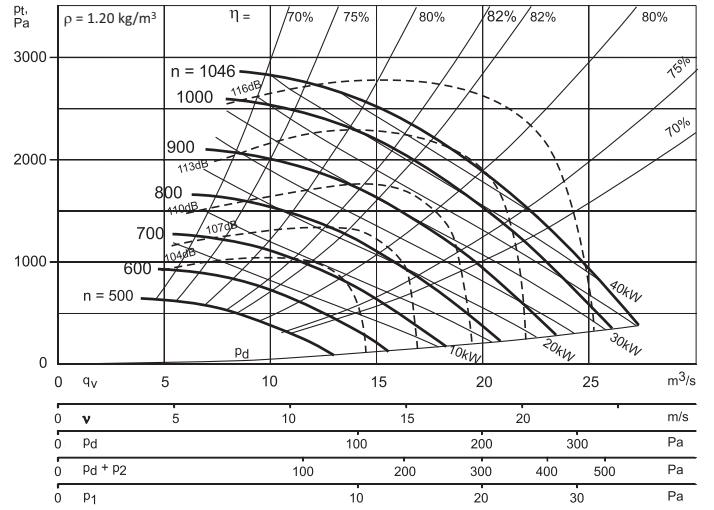

### CAL 800 - 85%

Moment of inertia:  $I_v = 8.81 \text{ kgm}^2$

Circumferential speed:  $u = 0.042 \times n, \text{ m/s}$

Impeller of DOMEX 500 or SAF-2205

Max. 2403 RPM

At 45 °C max. 2232 RPM

At 70 °C max 2138 RPM

Impeller of AISI 316L

Max. 1573 RPM

At 45 °C max. 1496 RPM

At 70 °C max. 1440 RPM

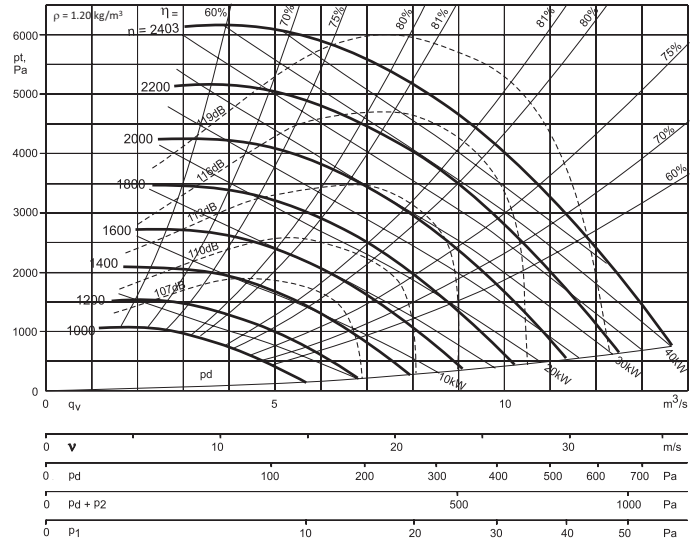

### CAL 900 - 85%

Moment of inertia:  $I_v = 14.2 \text{ kgm}^2$

Circumferential speed:  $u = 0.047 \times n, \text{ m/s}$

Impeller of DOMEX 500 or SAF-2205

Max. 2016 RPM

At 45 °C max. 1871 RPM

At 70 °C max. 1792 RPM

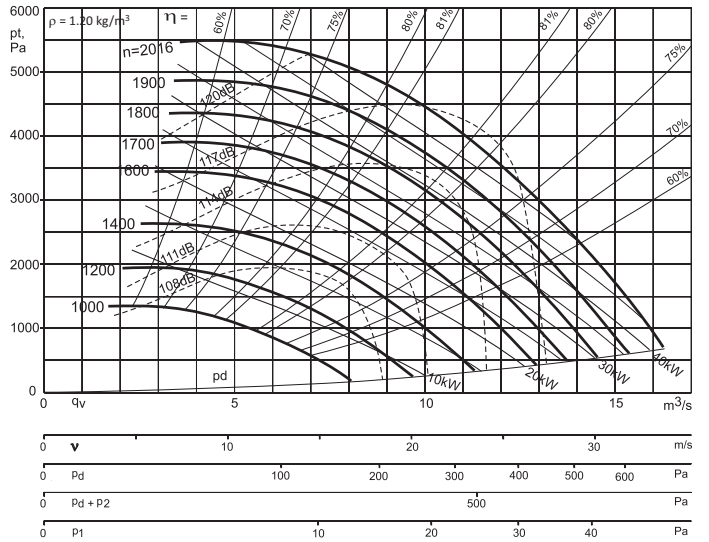

### CAL 1000 - 85%

Moment of inertia:  $I_v = 21.7 \text{ kgm}^2$

Circumferential speed:  $u = 0.052 \times n, \text{ m/s}$

Impeller of DOMEX 500 or SAF-2205

Max. 1719 RPM

At 45 °C max. 1597 RPM

At 70 °C max. 1530 RPM

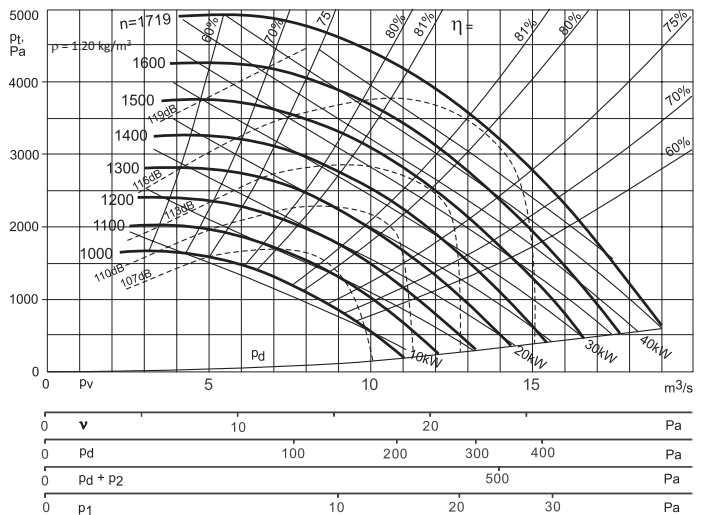

### CAL 1120 - 85%

Moment of inertia:  $I_v = 33.4 \text{ kgm}^2$

Circumferential speed:  $u = 0.059 \times n, \text{ m/s}$

Impeller of DOMEX 500 or SAF-2205

Max. 1450 RPM

At 45 °C max. 1348 RPM

At 70 °C max. 1291 RPM

Impeller of AISI 316L

Max. 1126 RPM

At 45 °C max. 1071 RPM

At 70 °C max. 1030 RPM

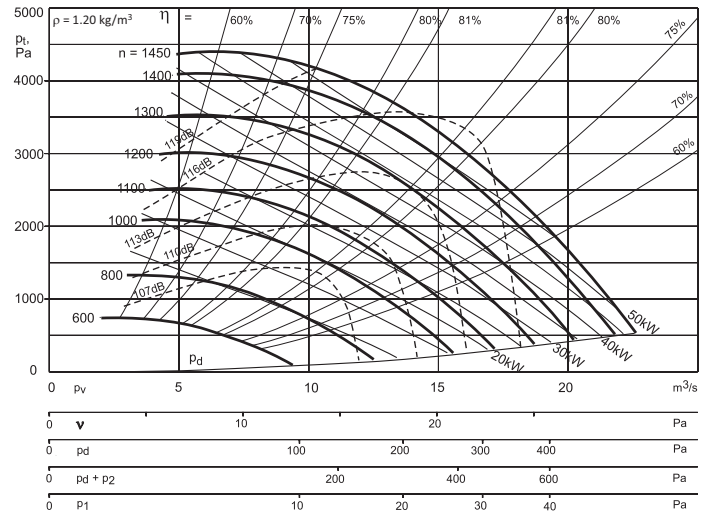

### CAL 1250 - 85%

Moment of inertia:  $I_v = 51.8 \text{ kgm}^2$

Circumferential speed:  $u = 0.065 \times n, \text{ m/s}$

Impeller of DOMEX 500 or SAF-2205

Max. 1230 RPM

At 45 °C max. 1143 RPM

At 70 °C max 1095 RPM

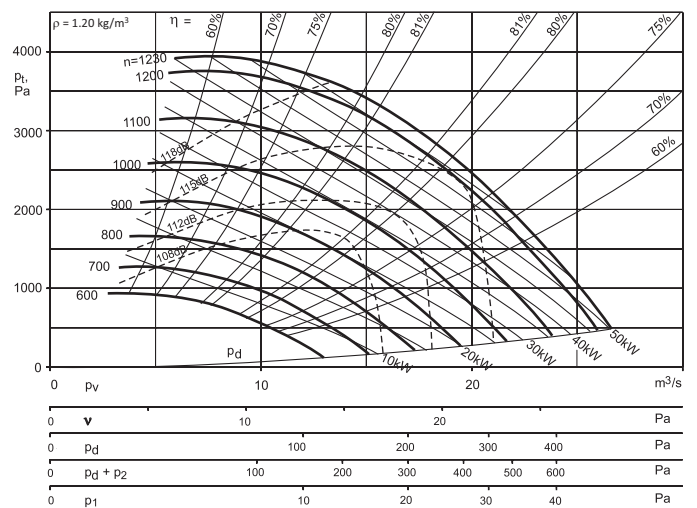

### CAL 400 - 70%

Moment of inertia:  $I_v = 0.34 \text{ kgm}^2$

Circumferential speed:  $u = 0.021 \times n, \text{ m/s}$

Impeller of DOMEX 500

Max. 5696 RPM

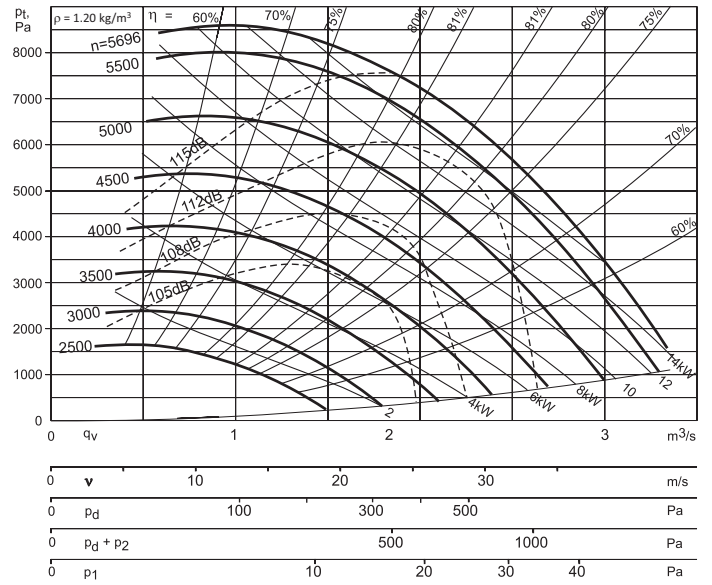

### CAL 500 - 70%

Moment of inertia:  $I_v = 1.05 \text{ kgm}^2$

Circumferential speed:  $u = 0.026 \times n, \text{ m/s}$

Impeller of DOMEX 500

Max. 3850 RPM

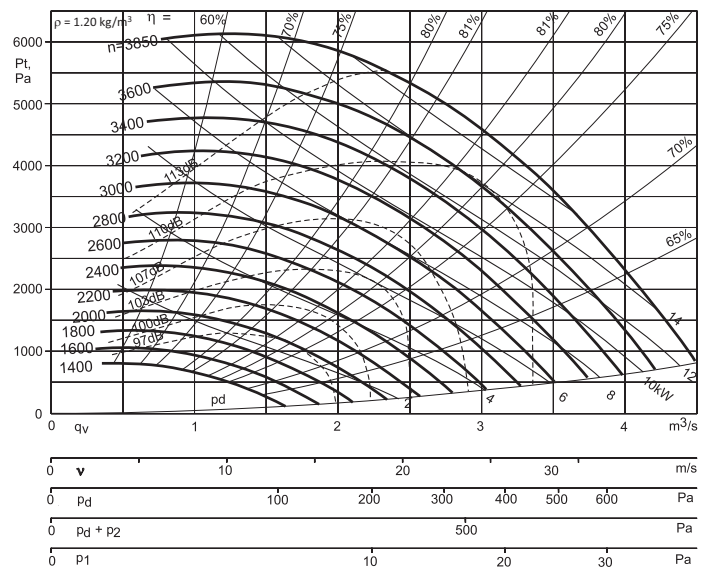

### CAL 630 - 70%

Moment of inertia:  $I_v = 3.20 \text{ kgm}^2$

Circumferential speed:  $u = 0.033 \times n, \text{ m/s}$

Impeller of DOMEX 500 or SAF-2205

Max. 3600 RPM

Impeller of AISI 316L

Max. 2733 RPM

At 45 °C max. 2600 RPM

At 70 °C max. 2502 RPM

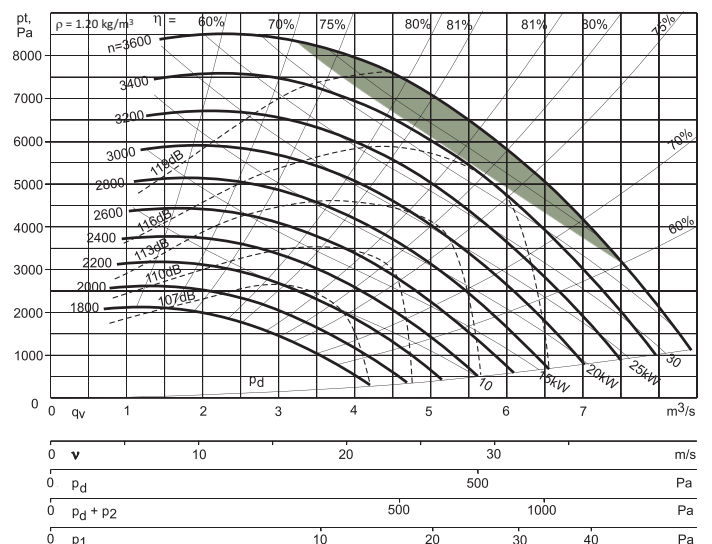

Please consider the choice of motor size carefully for fans to be used in the shaded area. The desired power may be unachievable.



Centrifugal fans CAL whip  
air into powerful motion  
- and deliver steady pressure  
where performance  
really matters

### CAL 710 - 70%

Moment of inertia:  $I_v = 5.20 \text{ kgm}^2$

Circumferential speed:  $u = 0.037 \times n, \text{ m/s}$

Impeller of DOMEX 500 or SAF-2205

Max. 3000 RPM

Impeller of AISI 316L

Max. 2284 RPM

At 45 °C max. 2173 RPM

At 70 °C max. 2091 RPM

Please consider the choice of motor size carefully for fans to be used in the shaded area. The desired power may be unachievable.

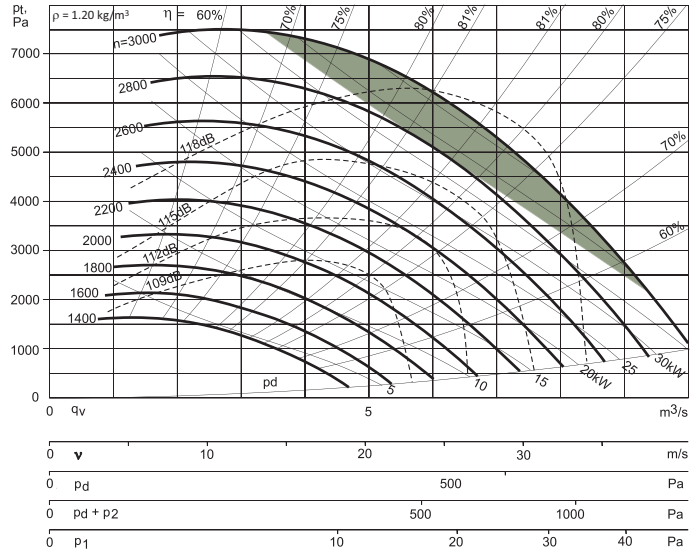

### CAL 800 - 70%

Moment of inertia:  $I_v = 8.40 \text{ kgm}^2$

Circumferential speed:  $u = 0.042 \times n, \text{ m/s}$

Impeller of DOMEX 500 or SAF-2205

Max. 2918 RPM

At 45 °C max. 2711 RPM

At 70 °C max. 2596 RPM

Impeller of AISI 316L

Max. 1910 RPM

At 45 °C max. 1817 RPM

At 70 °C max. 1749 RPM

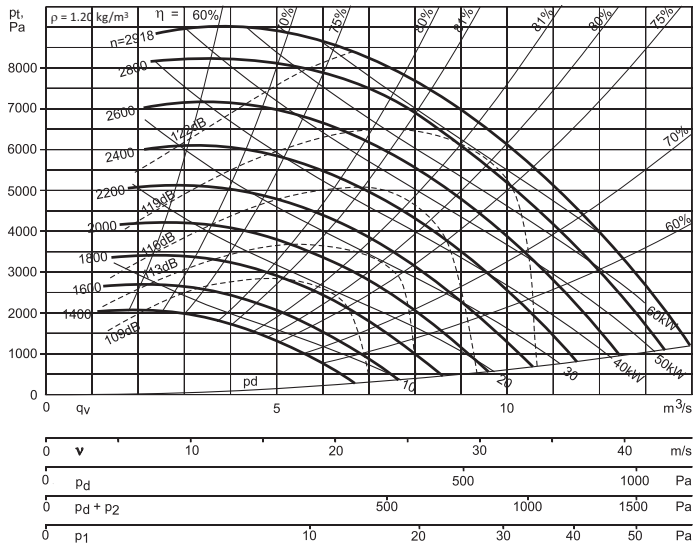

### CAL 900 - 70%

Moment of inertia:  $I_v = 13.5 \text{ kgm}^2$

Circumferential speed:  $u = 0.047 \times n, \text{ m/s}$

Impeller of DOMEX 500 or SAF-2205

Max. 2445 RPM

At 45 °C max. 2272 RPM

At 70 °C max. 2176 RPM

Please consider the choice of motor size carefully for fans to be used in the shaded area. The desired power may be unachievable.

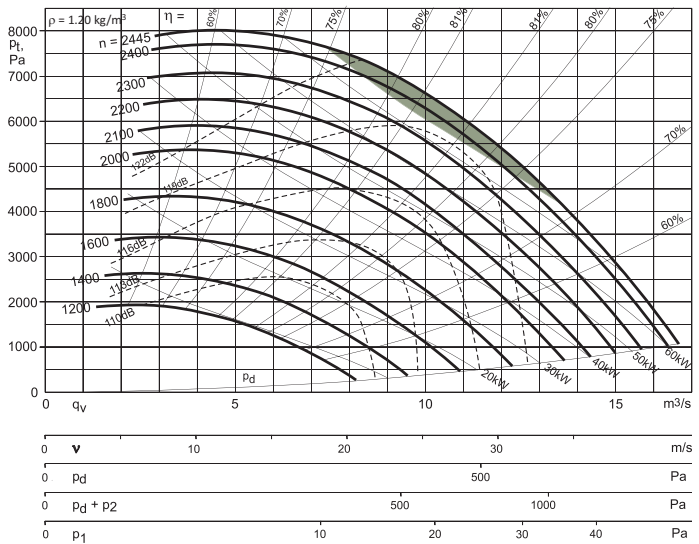

### CAL 1000 - 70%

Moment of inertia:  $I_v = 20.6 \text{ kgm}^2$

Circumferential speed:  $u = 0.052 \times n, \text{ m/s}$

Impeller of DOMEX 500 or SAF-2205

Max. 2088 RPM

At 45 °C max. 1940 RPM

At 70 °C max. 1858 RPM

Please consider the choice of motor size carefully for fans to be used in the shaded area. The desired power may be unachievable.

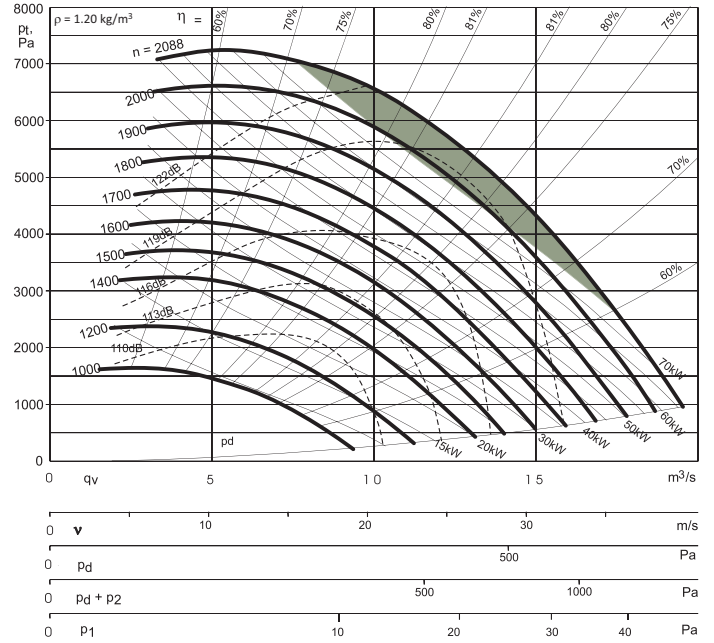

### CAL 1120 - 70%

Moment of inertia:  $I_v = 31.7 \text{ kgm}^2$

Circumferential speed:  $u = 0.059 \times n, \text{ m/s}$

Impeller of DOMEX 500 or SAF-2205

Max. 1761 RPM

At 45 °C max. 1636 RPM

At 70 °C max. 1567 RPM

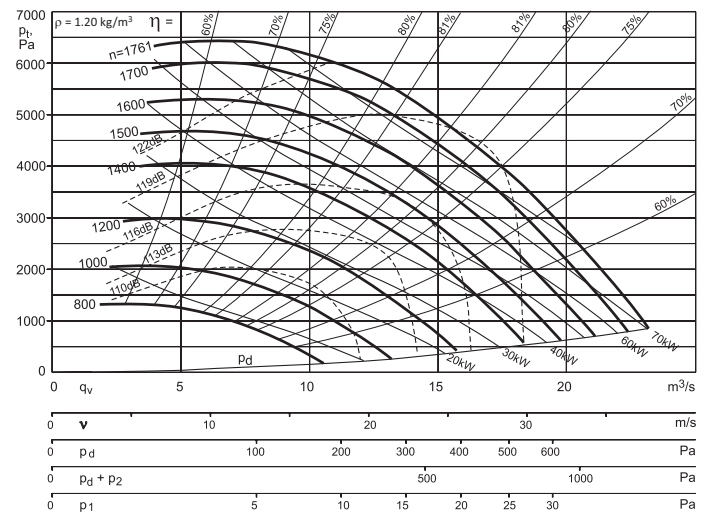

### CAL 1250 - 70%

Moment of inertia:  $I_v = 49.1 \text{ kgm}^2$

Circumferential speed:  $u = 0.065 \times n, \text{ m/s}$

Impeller of DOMEX 500 or SAF-2205

Max. 1494 RPM

At 45 °C max. 1388 RPM

At 70 °C max. 1329 RPM

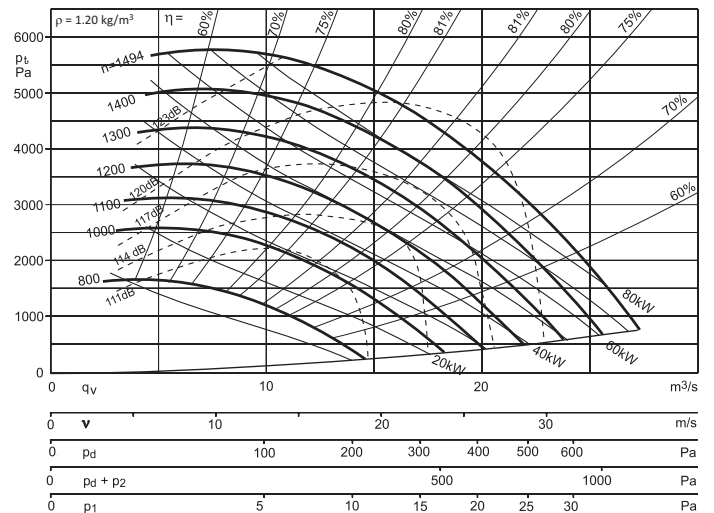

# Sound conditions

Fans in operation generate sound. The sound stems from electrical and mechanical workings inside the motor, bearings and other parts. Airflows that pass through the fan also contribute to the total sound picture.

The generation of sound is limited by careful design and production of fan parts. Particular important are the inlet funnel and impeller, which influence highly on the sound picture. In this connection, it must be noted that poor installation conditions, for example a sharp duct bend too close to the inlet opening, may increase sound generation considerably.

Electrical and mechanical sounds, as well as air sounds that pass out through the fan housing, can only be dampened by insulating the fan with a casing or walls of low-vibration materials.

Sounds generated in the impeller is distributed through the inlet and outlet openings to the duct system and further to the ventilated rooms. Calculation of sound conditions in the duct system and ventilated rooms, including dimensioning of silencers in the system, is only possible on the basis of the sound power level in the fan inlet and outlet openings. In connection with all considerations concerning sound, a sharp distinction must be made between the terms *sound power level* and *sound pressure level*.

The sound power level expresses how much sound energy is emitted through the fan inlet and outlet openings. It forms the basis for any calculation concerning the sound conditions in the connected duct systems and in served rooms.

The sound pressure level is a measure of the sound impression perceived by the human ear at a given location in the environment in which the fan is placed. It is measured with a sound meter and a microphone.

The sound pressure level depends on the fan sound power level, the distance from the fan and the silencing properties of the environment.

The fan sound properties are characterised by stating the sound pressure level, together with a precise description of the conditions under which the stated sound level occurs.

To compare the sound properties of fans, it is important to distinguish between the sound power and pressure levels. Remember to compare only identical levels, which also means that the distance from the fan and the silencing in the environment must be the same and hence comparable.

For a correctly designed fan, the sound power level depends primarily on the supplied airflow rate and the total fan pressure and can be read on the charts for the individual fans beginning on page 10.

The sound power level is stated in dB with reference value  $10^{-12}$  W, and applies within the normal working range of the fan and with a tolerance of  $\pm 5$  dB. If the sound power level needs to be divided into octave values, the sound power level in the different octave bands is determined by deducting the correction values in the table below from the total sound power level. The correction values depend on the blade frequency.

$$z \times \frac{n}{60}, \text{ where}$$

$z$  = number of blades = 8

$n$  = fan speed in RPM

Blade frequency [Hz]	Octave band [Hz]							
	63	125	250	500	1k	2k	4k	8k
90 - 180	7	4	7	12	17	22	27	32
180 - 360	11	7	4	7	12	17	22	27
360 - 710	13	11	7	4	7	12	17	22
710 - 1400	15	13	10	6	4	7	12	18

## Example

A centrifugal fan type CAL 710 has an output of  $5 \text{ m}^3/\text{s}$  at 3000 Pa and 2000 RPM.

**Blade frequency:**  $8 \times 2000 / 60 = 266 \text{ Hz}$

**Total sound power (page 12):** 111 dB

**Correction value (250 Hz):** 4 dB

**Sound power level:** 111 dB - 4 dB = 107 dB

The full octave analysis is in the table to the right.

Octave band [Hz]	63	125	250	500	1k	2k	4k	8k
Sound power level [dB]	100	104	107	104	99	94	89	84

# Regulation of airflow rate

Regulation of fan performance can be achieved in several ways, depending on the operating requirements.

## REGULATION METHODS

- Changing poles between two fixed RPMs in the ratio 3:2 (motor with 2 separate windings) or 2:1 (Dahlander winding motor).
- Frequency regulation
- A combination of the above



Danfoss frequency converter



WEG W22 motor

## Changing poles

For time-related variations in the airflow rate demand, for example night-time and daytime operation, it is recommended to fit the fan with a change-pole motor. When the fan is changed to different RPMs, the fan efficiency is unchanged.

The changing is usually controlled with a timer.

If other operating points are required and these cannot be achieved by changing poles, other regulation methods must be used.

## Frequency regulation

In systems with continually changing airflow rate demands or in systems with constant airflow rates regardless of external pressure conditions, frequency inversion can be used.

The fan efficiency remains virtually unchanged throughout the regulation range and no sound is generated as a result of the regulation.

# Quality and service



## Rest assured

The CAL centrifugal fans are produced in accordance with Novenco's well-known quality standards.

Novenco Building & Industry A/S is ISO certified and all fans are inspected and tested.

The fans are offered with options for technical guidance on installation, test of function and training of personnel.

## Warranty

Novenco provides according to law a standard 12 months warranty from the product is sent from the factory. The warranty covers materials and manufacturing defects. Wear parts are not covered. Extended warranty can be agreed upon.

## Important

This document is provided 'as is'. Novenco Building & Industry A/S reserves the right to changes without further notice due to continuous product development.

Pictures in the catalogue may show products with accessories fitted.

The fans are designed for continuous operation. The following kinds of operation may cause fatigue break in the impellers and endanger people.

- Operation in stall area, i.e. with counter pressure that pulsates – called pump mode
- Operation with exceedingly starts and stops
- Uneven flow velocity through fan

If in doubt, Novenco should be contacted to assess the suitability of the fans.

Copyright (c) 2009- 2025,  
Novenco Building & Industry A/S,  
All rights are reserved.

## Patents and trademarks

Novenco®, 诺文科, 诺万科 and 诺亮 are registered trademarks of Novenco Marine & Offshore A/S. ZerAx® is a registered trademark of Novenco Building & Industry A/S. AirBox™, NoVa™ and NovAx™ are trademarks of Novenco Building & Industry A/S. Other trademarks that appear in this document are the property of their respective owners.

## Quality and environment

Novenco Building & Industry A/S is certified in accordance with ISO 9001 and 14001. All Novenco Building & Industry's products are designed, developed and manufactured in Denmark.



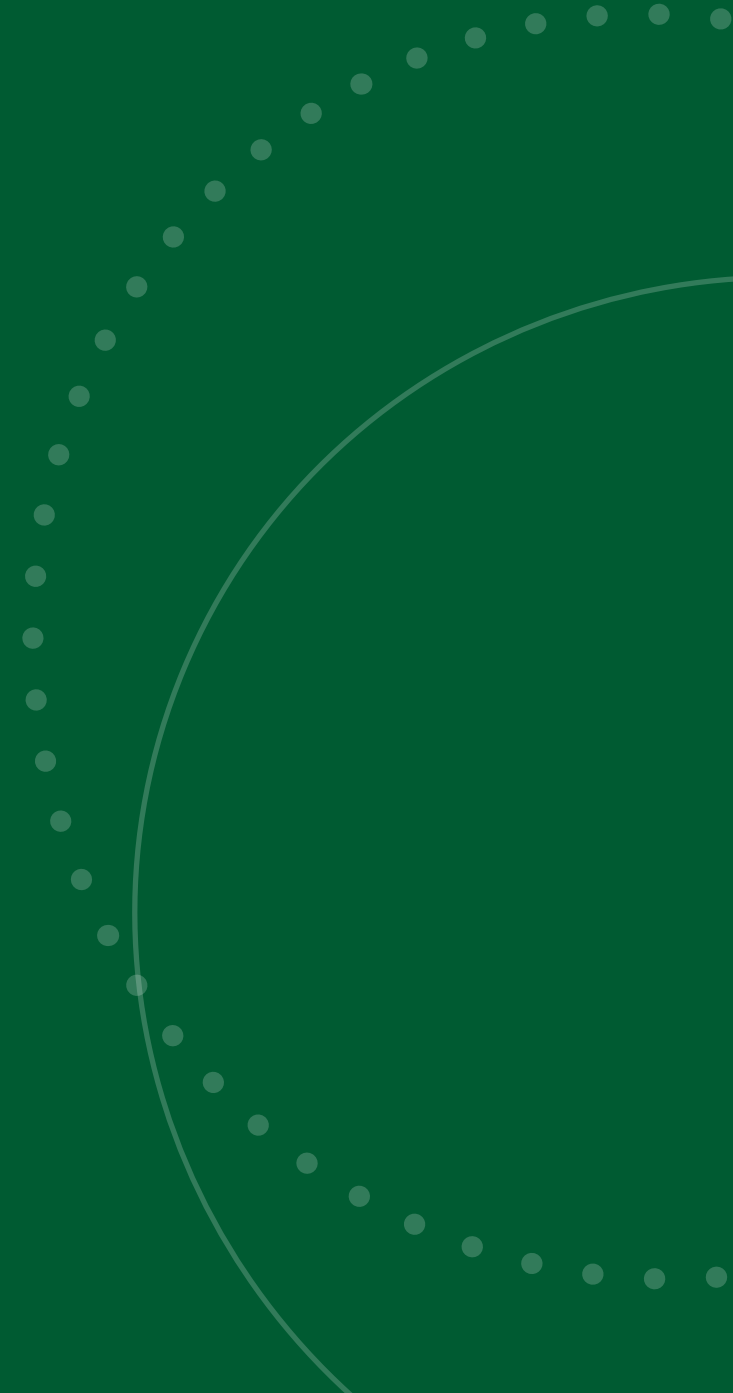

[info@novenco-building.com](mailto:info@novenco-building.com)

+45 70 77 88 99

[novenco-building.com](http://novenco-building.com)