

Building & Industry



SCHAKO Group

NOVENCO® ZerAx™ axial fans

Standard, hot smoke, ATEX and EX



Product facts

Product

The Novenco® ZerAx® series of axial flow fans uses innovative design to reduce power consumption and to better fan efficiency. The work environment benefits from the low fan sound levels.

Application

ZerAx fans are for comfort and industrial ventilation. Versions for standard temperature, hot smoke and ATEX zones and marine EX application are available.

Ranges

ZerAx fans for duct installation are designated AZN or AZW. Fans with integrated inlet cones for building in to air handling units are designated AZL.

The Standard Range fans include AZL and AZN fans and comprise a number of fixed size-airflow-pressure combinations.

Fan specifications

Casing sheet thicknesses: 2 or 3 mm for AZL, 2 or 4 mm for AZN, and 10 mm for AZW

Hub sizes: Ø160 or Ø350 mm for AZL, Ø160, Ø350 or Ø560 mm for AZN, and Ø350 or Ø560 mm for AZW

Impeller diameters: Ø250 to Ø500 mm for Ø160 hubs, Ø500 to Ø1250 mm for Ø350 hubs, Ø1000 to Ø2000 mm for Ø560 hubs

Blade angles: Adjustable between 25° and 80°, depends on pressure

Airflow rates: 0.1 to 125 m³/s

Air pressures: Increases up to 3400 Pa for standard temperature and up to 3100 Pa for hot smoke fans

Fan efficiencies, without motors: Up to 92% at standard temperature and up to 89% for hot smoke fans

Reverse operation: Shorter periods up to max. allowable RPMs for normal direction. Airflow is reduced to 50% and pressure to 25% for the same system characteristics.

Motors

Voltages: 3x220 - 3x690 V at 50 or 60 Hz

Efficiency classes: IE1- IE5

Speed control: Direct or frequency converter

Mounting: Enclosed in motor mount or outside the mount through a long hub

Terminal boxes: Steel or plastic mounted on fan casings

Dimension standard: IEC-72

Electrical standard: IEC-34

Enclosure: IP54, IP55, IP56, IP65 or IP66

Insulation: Class B to H

Materials

Blades, guide vanes and hub: AlSi10

Inner hub: Cast steel galvanised

Fan casing and inner tube: Metallic coated steel sheet according to EN10346:2015 for light motors and hot-dip galvanised steel for heavy motors

Hub cap: Sea-water resistant aluminium

Motor mount: Hot-dip galvanised steel

Classifications

Flange standards: Eurovent 1/2 for AZN and AZL; DIN 24154 R4 for AZW

Technical capacities: AMCA 211-13; DS/ISO 21940-11:2016; DS/ISO 21940-14:2012; EN ISO 5801:2017

Environment: DS/EN ISO 12944-2:2017, corrosion category C3, optionally C4 or C5

Sound: ANSI/AMCA 300-14; AMCA 311-16

Temperature range: -20 to 50 °C

Temperature range, max.: -40 to 120 °C

Temperature range, hot smoke: F300 according to EN 12101-3 for AZL and AZN fans for at least 1 hours at 300 °C

Marine motor classification:

Refer to AirBox program

ATEX and marine EX: AZN ATEX meet directive 2014/34/EU for category 2G/D; AZW EX meet guideline IACS F29/2005

Calculation software:

AirBox program is certified by TÜV for the ZerAx range of fans.

Accessories

- Acoustic diffusers with or without cores
- Anti-vibration mounts
- Anti-vibration mounting plate
- Counter flange
- Damper type SBC
- Duct spigots
- Fan casing extension
- Flexible connection (PERL / Maritex)
- Frequency converter
- Hub cover
- Inlet cone with wire guard
- Inlet wire guard
- Kit for lubrication of motor
- Low temperature motor option
- Measuring pipe
- Outlet wire guard
- Painted for C4/5 environments
- Plate for vertical mounting
- Roof hood type HAN
- Round-to-square diffuser
- Short, long, extra long and double length diffusers
- Silencers with or without cores
- Space heater for motor
- Support frame for horizontal mounting
- Thermal motor protection



Description

The design of the Novenco ZerAx fans builds on our renowned No-vAx™ fans and includes several improvements. The materials and fan design are contemporary and form the basis for high fan efficiencies. The efficiencies ensure low enough power consumption and noise levels to comply with future environmental legislation.

As with previous fan series, the ZerAx application span is as wide as the product range. The fans already help keep high levels of performance at minimum costs within as diverse areas as the windmill sector, data centres, residential housing, car park ventilation and built into air handling units.

On-board ships and in offshore facilities, the fans save barrels of oil and improve crew conditions by lowering noise levels.

Design

Central to the design is the impeller assembled from aluminium cast hub parts and blades. The impeller is fitted in an inner tube, in which cast profiled guide vanes are mounted on the motor mount.

All ZerAx versions have the same impeller and motor arrangement in the fan casing. The installation requires precision and is essential to the fan efficiency and the very little blade clearance.

Materials

The materials and characteristics of these are key to the fan performance. The weight is relatively low through use of light and strong materials. Most parts are of aluminium and can withstand high strains.

For further weight savings, the fan casing is shortened and parts are cast and machined with high precision.

Ground-breaking efficiency

Isolated measurements of the fan efficiencies show these to go up to 92%. To complement these the ZerAx fans are offered with a wide motor range in efficiency classes up to IE5 for PM motors. Together with highly efficient frequency converters it thereby is possible to design systems with total efficiencies of up to 85%.

All ZerAx fans can operate in reverse for shorter periods.

Classifications

The ZerAx fans are CE-certified and the design has been tested and specifications verified according to the standards EN ISO 5801 and AMCA 300 by the largest laboratory in Northern Europe.

In the standard version, the ZerAx fans are for operation in unheated low corrosive environments according to DS/EN ISO 12944-2 and corrosion category C3. Versions for categories C4 and C5 are also available.

Fans for hot smoke and high temperature operation are available as fan types AZL and AZN. These are tested and certified for smoke

and heat control systems and for use with frequency converters as variable speed-control of smoke fans according to EN 12101-3.

The ZerAx fan type AZN size Ø1600 is certified by the Underwriters Laboratories (UL).

Optimal blade angles

The optimal fan performance is a unique balance between RPMs and the angle of the impeller blades. The angles are found with the AirBox program and input to the fan production. The angles lie between 25° and 80° in 1° increments for all hub sizes.

ATEX and EX applications and classifications

The AZN ATEX fans with hub sizes Ø350 and Ø560 comply with the directive 2014/34/EU for equipment installed in explosive atmospheres and environments. The fans are suited for removal of hazardous gases and for service in such environments.

The AZW EX fans with hub size Ø350 for marine use follow the guidelines in IACS F29/2005 for non-sparking fans. The fans are intended for transport of air containing flammable gases.

Hot smoke applications

The AZL and AZN fans for removal of hot smoke from fires are approved according to EN12101-3.



AirBox calculation program

The AirBox program is Novenco's calculation and configuration tool. Input to the program are requirements for airflow and pressure as well as specific characteristics of the operating environment. Further requirements for the fan, motor and accessories are also input and form the basis for calculation of possible solutions.

Novenco AirBox

is free and available on www.novenco-building.com.

It is certified by TÜV Süd in Germany, requires registration and checks automatically for updates.



AirBox™ TÜV certificate



AMCA Certification

Novenco Building & Industry A/S certifies that the ZerAx fans shown herein are licensed to bear the AMCA Seal. The ratings shown are based on tests and procedures performed in accordance with AMCA Publications 211 and 311 and comply with the requirements of the AMCA Certified Ratings Program.

Inside ZerAx

Minimum blade tip clearance

The clearance between the impeller blade tips and the fan casing is decisive for the performance. The high precision in the production of the casing, in the fan assembly and in the milling of the impeller blades, are key to the minimum clearance.

Unique blade efficiency

The blades are designed to move air efficiently and bring the fan efficiency up to 92%, which is the highest level ever for axial flow fans.

Profiled guide vanes of aluminium

Vanes are cast in aluminium and screwed on to the motor mount and fan casing. The vanes are optimised to reduce air rotation after the fan.

Innovative hub design

The hub parts, cap and cover (optional) are designed for optimal performance. All parts are in aluminium. The hub is assembled from cast parts in between which the impeller blade roots are inserted.

Durable fan casing

The fan casing is of strong material and kept short to optimise durability. The design and material add rigidity and minimises critical vibrations.

Extended fan casing - optional

Large motor sizes are accommodated through a long hub and extension of the fan casing. The long hub allows for position of the motor outside the motor mount.

Frequency regulated motor - optional

Motors offered in connection with ZerAx can be regulated with external frequency converters.

High efficiency motors

Motors are available in efficiency classes IE1 to IE5. Both traditional AC motors and high efficiency PM motors are part of the motor programme.

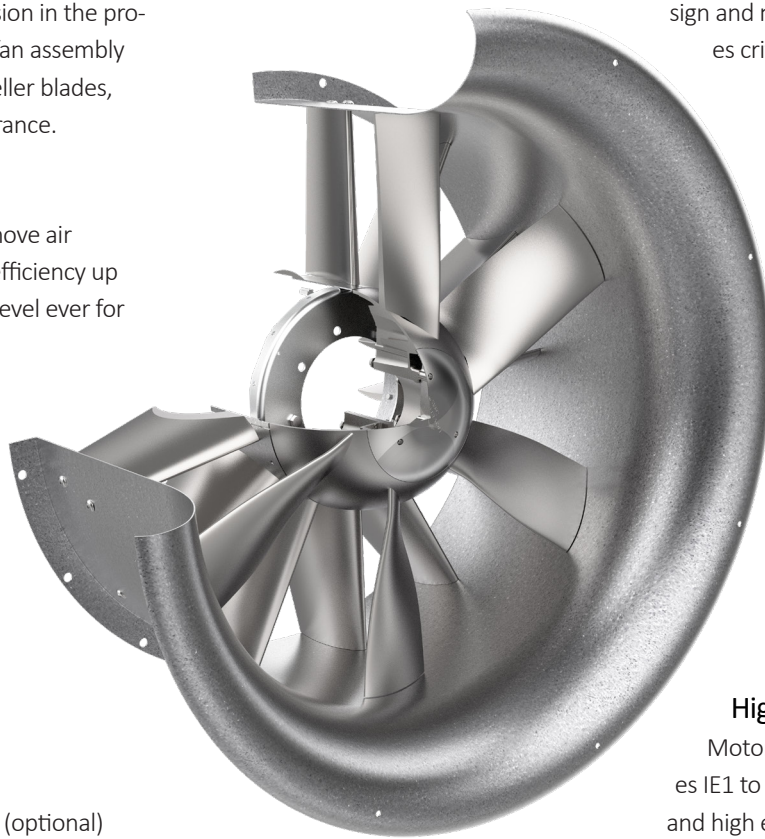

Types

The Novenco ZerAx fan series comprises types and installation sizes for land and marine environments and a wide range of purposes.

The airflow rates depend on type and size and range from 0.1 to 125 m³/s. Pressure increases are up to 3400 Pa for standard temperature, 3300 Pa for ATEX and EX, and 3100 Pa for hot smoke fans.

The fan casings are cylindrical with connection flanges at both ends for AZN and AZW, and at one end for AZL.

The motor mounts are aerodynamically designed to optimise airflows.

The motor mounts and fan casings are of pre-coated sheet metal or hot-dip galvanised steel.



AZN with Ø350 hub

The impellers are mounted directly on the motor shafts. Large motors are displaced outside the motor mounts and connected to the impellers through extended hubs.

The blades are mounted on the hubs and adjusted to the correct angles according to order specifications.

The motors are flange motors, mounted on the outlet sides, and fitted with electrical cables that pass out through the fan casings to terminal boxes.

The direction of airflow for ZerAx fans is impeller -> motor.

AZN for duct installation

The AZN fans for duct installation can be fitted with cones or diffusers and thereby easily turned into fans with free inlet or outlet. The fan casing is quite durable and with a sheet thickness that depends on motor size. It is made in either 2 or 4 mm metallic coated steel sheet.

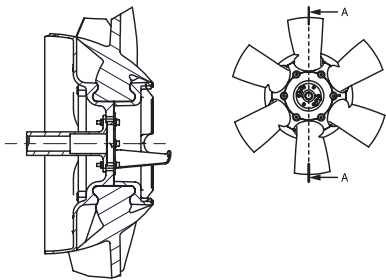

AZN 1000 impeller with Ø560 hub

The flange pitch diameter, number of holes and hole sizes follow the Eurovent 1/2 standard.

AZW for heavy duty

The AZW fans display the same characteristics as and have almost specifications identical to the AZN. The main difference is the 10 mm thick fan casing sheet. This much thicker casing makes the AZW well-suited for rough conditions, for example marine environments, where durability is essential.



AZW 1000 with Ø350 hub

The flange pitch diameter, number of holes and hole sizes follow the DIN 24154 R4 standard.

AZL for AHUs and retrofit

The AZL fans are compact and with integrated inlet cones intended for installation in air handling units.

The design and specifications are similar to the AZN fans with some modifications. The fan casing sheet thickness is kept to a minimum of 2 or 3 mm and with impeller diameters between Ø250 and Ø1000, depending on hub size.

The flange pitch diameter, number of holes and hole sizes follow the Eurovent 1/2 standard.

Hot smoke fans

The fan types AZL and AZN are approved as hot smoke fans in accordance to EN 12101-3 for at least 1 hour at 300 °C. The max. pressure and fan efficiencies are reduced to 3100 Pa and 89%, respectively.



AZL 315 with Ø160 hub

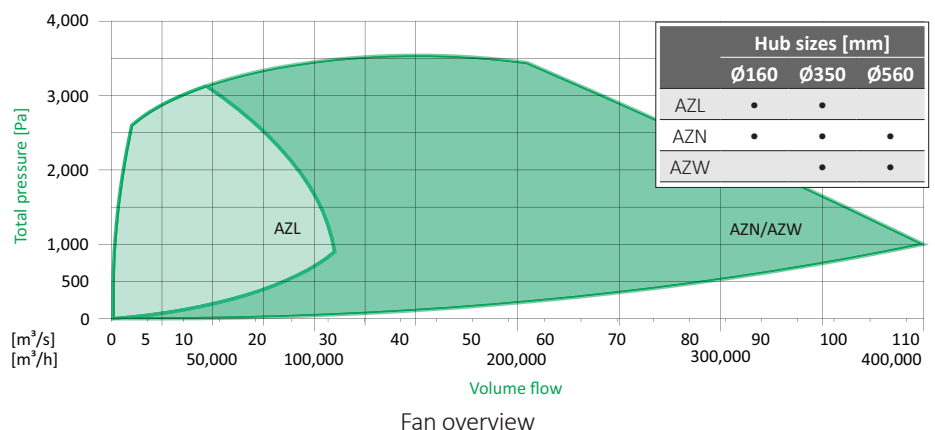

Fan sizes and performance

The general performance curves show the fan efficiencies of each of the three hub sizes. Compare these to the specific performance curves to see what fan sizes have the desired efficiencies.

The specific curves are for fans with frequency converters and with capacities based on installation type D for fans with ducts on inlet and outlet. Installation type D is in accordance with DS/EN ISO 5801:2017. The air density is $\rho = 1.20 \text{ kg/m}^3$.

Refer to Novenco AirBox for configuration and calculation of blade angles, motors, power consumption, sound levels etc. See section "AirBox calculation program" on page 3.

Please note that ZerAx fans have smaller form factors than other fans, as ZerAx fan sizes quite often are smaller for comparable airflows and pressures. Hence, operational cost and space requirements are lower.

The ZerAx fans present a sound alternative to centrifugal fans in ventilation and air conditioning systems with varying airflow rate requirements.

Hub diameters	Impeller diameters [mm] ³																			
	Ø250	Ø280	Ø315	Ø355	Ø400	Ø450	Ø500	Ø560	Ø630	Ø710	Ø800	Ø900	Ø1000	Ø1120	Ø1250	Ø1400	Ø1600	Ø1800	Ø2000	
Ø160 ²	4919	4747	4570	4408	4269	4145	4086													
Ø350							3660	3460	3238	3000	2751	2498	2270	2029	1809					
Ø560													2034	1893	1751	1599	1419	1262	1130	

Optimal RPMs for frequency regulated ZerAx impellers ¹

1. This is for optimal installation conditions at 20 °C. Other temperatures reduce the RPMs.
2. For hub size Ø160 the RPMs are maximum values. Refer to AirBox for specific calculations.

3. All hub-impeller combinations are available as fans for standard temperatures and for hot smoke. Hub sizes Ø350 and Ø560 are, furthermore, also available as ATEX compliant fans.

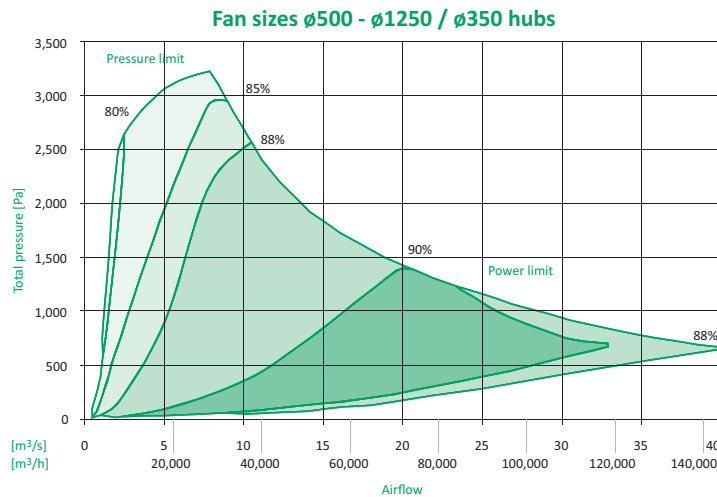
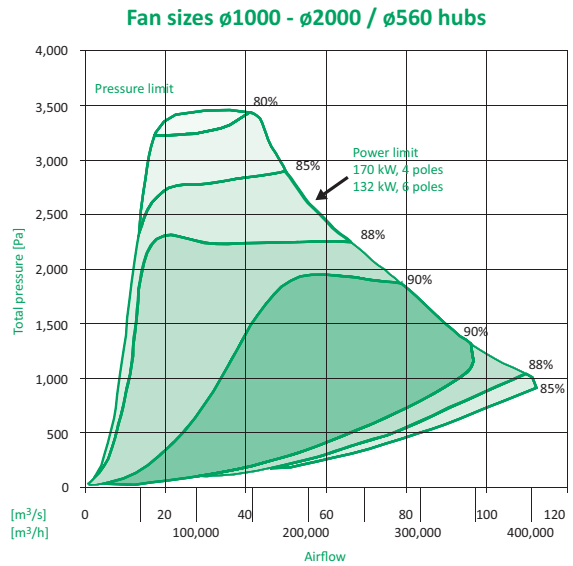
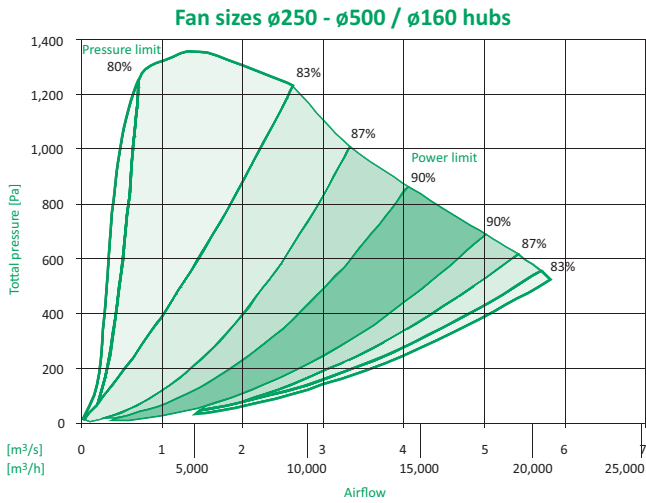

General performance curves

The AMCA performance certified is for installation type D, ducted inlet, ducted outlet.

The standard fans as well as the certified smoke fans are ready for frequency converter operation with RFI filters according to the product standard EN61800-3 class C2.

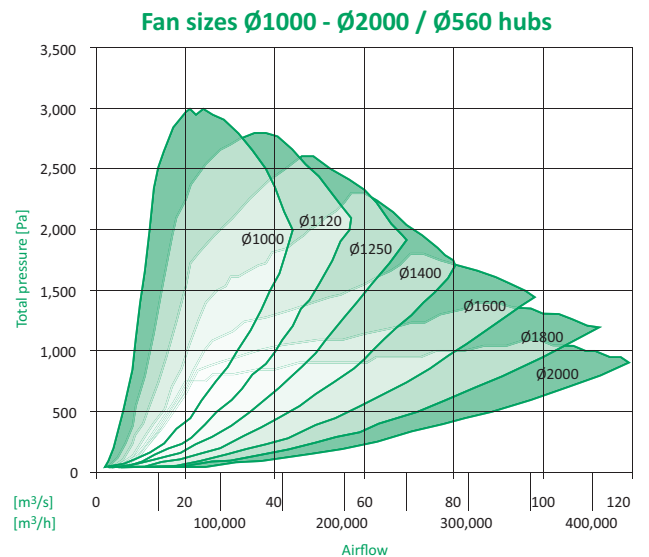
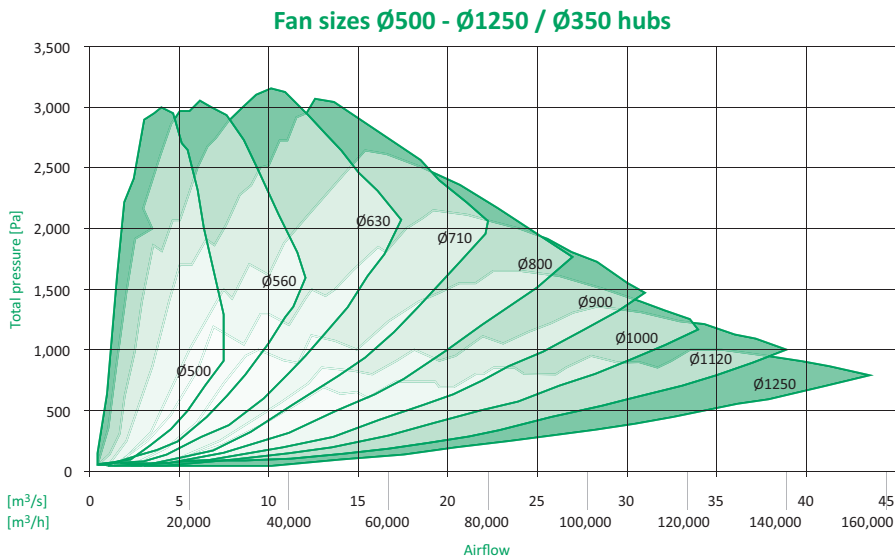
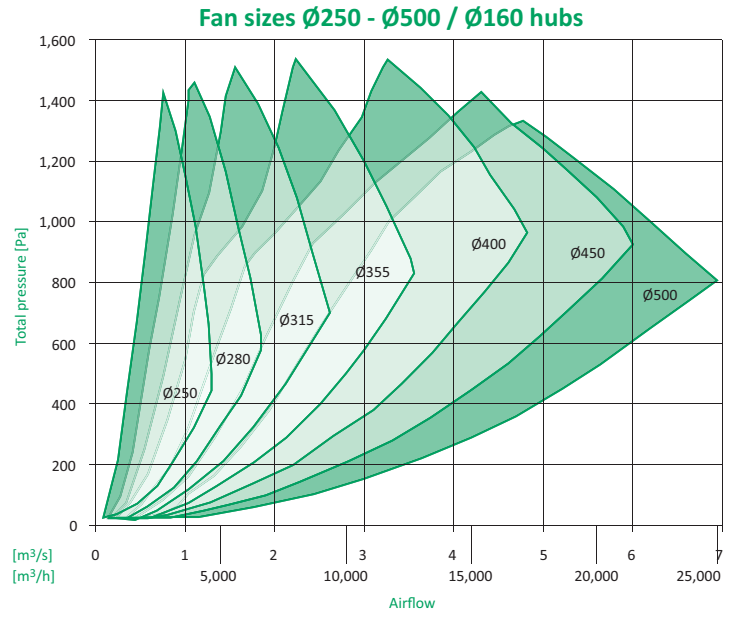

Specific performance curves for fans with frequency converters

Standard range fans

The Standard Range fans are pre-defined fan configurations available for quick delivery. The range is based on sales statistics from the introduction of the ZerAx fans in 2010 and to 2015. The analysis shows a demand for relatively small and high efficient fans. Big fans and fans with high airflows are, however, also in the range.

The Standard Range fans comprise fans for operation at temperatures between -20 to +50 °C. The range covers flange and bracket mounted AZL fans with Ø160 and Ø350 hubs and flange-mounted AZN fans, also with Ø160 and Ø350 hubs.

The standardisation encompass impeller diameters, hub sizes, blade angles and motors. The fan configurations cannot be

modified. Please note that fans with IE4 motors include frequency converters, while fans with IE3 motors do not.

Parts from the accessory programme fit the fans, but has to be ordered on separate orders.

All Standard Range fan configurations are available in AirBox and calculate the same way as custom configurations.

The AMCA performance certified is for installation type D, ducted inlet, ducted outlet.

Item no.	Fan size [mm]	Optimal performance						Total pressure performance indicators									
		Airflow [m ³ /s]	Airflow [m ³ /h]	Total pressure [Pa]	Static pressure [Pa]	Fan eff. [%]	Power input [kW]	200 Pa		400 Pa		600 Pa		800 Pa		1,000 Pa	
								Airflow [m ³ /s]	Power input [kW]	Airflow [m ³ /s]	Power input [kW]	Airflow [m ³ /s]	Power input [kW]	Airflow [m ³ /s]	Power input [kW]	Airflow [m ³ /s]	Power input [kW]
30043418	Ø250	0.75	2,700	1,000	859	81.8	1.135	0.35	0.08	0.49	0.24	0.60	0.44	0.69	0.68	0.77	0.94
30043419	Ø280	0.91	3,276	874	743	84.3	1.168	0.48	0.11	0.67	0.32	0.83	0.59	0.95	0.90		
30043420	Ø315	1.10	3,960	709	589	86.1	1.109	0.66	0.15	0.93	0.44	1.15	0.80				
30043421		1.25	4,500	920	765	86.6	1.599	0.63	0.15	0.89	0.41	1.10	0.76	1.27	1.17		
30043422		1.40	5,040	1,150	956	86.9	2.188	0.65	0.15	0.92	0.42	1.12	0.78	1.29	1.20	1.45	1.67
30043423	Ø355	1.40	5,040	594	474	86.5	1.178	0.86	0.20	1.21	0.56	1.48	1.02				
30043424		1.55	5,580	757	609	87.1	1.623	0.83	0.19	1.17	0.54	1.43	0.98				
30043425		1.80	6,480	960	761	87.5	2.332	0.87	0.20	1.23	0.56	1.50	1.03	1.73	1.59		
30043426	Ø400	2.00	7,200	1,111	865	87.6	2.964	0.85	0.19	1.20	0.55	1.47	1.01	1.70	1.55	1.90	2.17
30043427		1.80	6,480	482	358	86.0	1.238	1.19	0.28	1.68	0.78						
30043428		2.00	7,200	597	445	86.6	1.663	1.18	0.27	1.67	0.77						
30043429	Ø450	2.25	8,100	775	582	87.2	2.362	1.18	0.27	1.67	0.76	2.04	1.40				
30043430		2.50	9,000	960	722	87.6	3.202	1.19	0.27	1.68	0.77	2.06	1.41	2.37	2.17		
30043431		2.75	9,900	1,081	793	87.8	3.910	1.18	0.27	1.67	0.76	2.05	1.40	2.37	2.16	2.64	3.02
30043432	Ø500	2.10	7,560	338	233	85.3	1.017	1.71	0.40								
30043433		2.40	8,640	462	325	86.1	1.550	1.68	0.39	2.37	1.10						
30043434		2.80	10,080	621	434	87.0	2.359	1.66	0.38	2.35	1.08	2.88	1.98				
30043435	Ø550	3.10	11,160	764	535	87.6	3.161	1.66	0.38	2.35	1.07	2.87	1.97				
30043436		3.50	12,600	925	633	88.1	4.244	1.67	0.38	2.36	1.07	2.89	1.97	3.34	3.04	3.74	4.24
30043437		2.80	10,080	314	192	87.3	1.216	2.25	0.51								
30043439	Ø600	3.10	11,160	391	241	88.0	1.641	2.26	0.51								
30043440		3.50	12,600	508	317	88.7	2.367	2.24	0.51	3.17	1.43						
30043441		3.90	14,040	630	392	89.4	3.213	2.22	0.50	3.15	1.41	3.85	2.59				
30043442		4.30	15,480	769	480	89.9	4.247	2.22	0.49	3.14	1.40	3.84	2.57				

Flange-mounted ZerAx AZL fans with Ø160 hubs and IE3 motors

The AMCA performance certified is for installation type D, ducted inlet, ducted outlet.

Item no.	Fan size [mm]	Optimal performance						Total pressure performance indicators									
								200 Pa		400 Pa		600 Pa		800 Pa		1,000 Pa	
		Airflow [m ³ /s]	Airflow [m ³ /h]	Total pressure [Pa]	Static pressure [Pa]	Fan eff. [%]	Power input [kW]	Airflow [m ³ /s]	Power input [kW]	Airflow [m ³ /s]	Power input [kW]	Airflow [m ³ /s]	Power input [kW]	Airflow [m ³ /s]	Power input [kW]	Airflow [m ³ /s]	Power input [kW]
30043625	Ø560	2.92	10,512	788	704	83.1	3.205	1.45	0.35	2.05	0.98	2.51	1.80	2.89	2.78		
30043626		3.11	11,196	995	899	84.0	4.232	1.37	0.33	1.94	0.93	2.38	1.70	2.75	2.62	3.07	3.66
30043627		3.51	12,636	1,217	1,094	84.3	5.771	1.40	0.33	1.98	0.94	2.43	1.73	2.80	2.66	3.13	3.71
30043628		3.47	12,492	1,434	1,314	84.9	6.657	1.27	0.30	1.79	0.84	2.19	1.55	2.53	2.38	2.83	3.33
30043629		4.03	14,508	1,795	1,634	85.2	9.509	1.32	0.31	1.87	0.88	2.29	1.61	2.65	2.48	2.96	3.47
30043630		4.44	15,984	1,940	1,744	85.0	11.353	1.40	0.33	1.99	0.93	2.43	1.72	2.81	2.64	3.14	3.69
30043631		4.78	17,208	2,418	2,191	85.3	15.020	1.37	0.32	1.94	0.91	2.38	1.67	2.75	2.58	3.07	3.60
30043632		3.67	13,212	643	560	85.2	3.207	2.02	0.47	2.85	1.34	3.49	2.45				
30043633	Ø630	4.05	14,580	780	678	85.8	4.231	2.02	0.47	2.86	1.33	3.51	2.45	4.05	3.77		
30043634		4.50	16,200	974	849	86.4	5.771	2.01	0.46	2.84	1.31	3.48	2.41	4.02	3.72	4.50	5.19
30043635		4.89	17,604	1,231	1,083	87.0	7.783	1.94	0.45	2.75	1.26	3.36	2.31	3.88	3.56	4.34	4.98
30043636		5.28	19,008	1,403	1,231	87.4	9.505	1.96	0.45	2.78	1.27	3.40	2.33	3.93	3.59	4.39	5.02
30043637		5.64	20,304	1,576	1,379	87.6	11.289	1.98	0.45	2.80	1.28	3.43	2.35	3.96	3.61	4.43	5.05
30043638		6.07	21,852	1,816	1,588	87.9	13.927	1.97	0.45	2.78	1.27	3.41	2.32	3.94	3.58	4.40	5.00
30043639		6.67	24,012	2,256	1,980	88.2	18.813	1.96	0.44	2.77	1.25	3.39	2.30	3.91	3.55	4.38	4.96
30043640		7.00	25,200	2,385	2,082	88.2	20.787	2.03	0.46	2.87	1.30	3.51	2.39	4.05	3.68	4.53	5.14
30043641	Ø710	4.58	16,488	536	455	88.8	3.207	2.76	0.62	3.90	1.76						
30043642		5.00	18,000	659	563	89.4	4.227	2.74	0.61	3.87	1.73	4.74	3.18				
30043643		5.58	20,088	816	696	89.9	5.766	2.72	0.60	3.85	1.71	4.71	3.14	5.44	4.83		
30043644		6.14	22,104	1,018	873	90.4	7.782	2.68	0.59	3.79	1.68	4.64	3.08	5.36	4.74	5.99	6.63
30043645		6.67	24,012	1,152	981	90.5	9.506	2.74	0.60	3.87	1.71	4.74	3.14	5.48	4.83	6.12	6.75
30043646		6.70	24,120	1,367	1,195	90.7	11.231	2.59	0.57	3.66	1.61	4.48	2.96	5.17	4.56	5.78	6.37
30043647		7.75	27,900	1,600	1,369	90.8	15.093	2.73	0.60	3.85	1.70	4.72	3.12	5.45	4.81	6.09	6.72
30043648		7.92	28,512	1,679	1,439	90.8	16.182	2.75	0.61	3.89	1.71	4.76	3.15	5.50	4.85	6.15	6.78
30043649		9.00	32,400	1,900	1,589	90.5	20.756	2.89	0.64	4.09	1.81	5.01	3.32	5.79	5.12	6.47	7.15
30043624		Ø800	5.55	19,980	400	326	89.5	2.955	4.24	0.95	5.99	2.68					
30043650	6.33		22,788	463	367	89.5	3.753	4.11	0.92	5.82	2.59						
30043651	7.28		26,208	608	482	89.5	5.626	4.20	0.94	5.94	2.65	7.27	4.87				
30043652	8.22		29,592	746	585	89.5	7.715	4.23	0.95	5.98	2.68	7.33	4.92				
30043653	8.78		31,608	864	680	89.5	9.504	4.20	0.94	5.94	2.65	7.27	4.88	8.40	7.51		
30043654	9.25		33,300	975	771	89.5	11.211	4.15	0.93	5.87	2.62	7.19	4.82	8.31	7.42	9.29	10.37
30043655	10.20		36,720	1,211	964	89.5	15.242	4.13	0.92	5.84	2.61	7.15	4.79	8.25	7.38	9.23	10.31
30043656	11.03		39,708	1,380	1,090	89.5	18.696	4.18	0.93	5.91	2.64	7.23	4.85	8.35	7.46	9.34	10.43
30043657	11.80		42,480	1,529	1,197	89.5	22.105	4.24	0.95	6.00	2.68	7.35	4.93	8.49	7.58	9.49	10.60
30043658	12.39		44,604	1,751	1,386	89.5	26.663	4.19	0.94	5.92	2.65	7.25	4.86	8.37	7.49	9.36	10.46
30043659	6.50		23,400	384	283	88.5	3.231	4.62	1.04	6.53	2.95						
30043660	7.69		27,684	524	383	88.5	5.184	4.67	1.05	6.61	2.98						
30043661	8.56		30,816	712	538	88.5	7.746	4.50	1.02	6.36	2.88	7.80	5.28				
30043662	9.25		33,300	810	606	88.5	9.482	4.57	1.03	6.46	2.92	7.91	5.36	9.13	8.25		
30043663	9.39		33,804	953	744	88.3	11.280	4.28	0.97	6.06	2.74	7.42	5.04	8.56	7.76		
30043664	10.33		37,188	1,177	923	88.3	15.225	4.24	0.96	6.00	2.72	7.35	4.99	8.48	7.69	9.48	10.75
30043665	11.03		39,708	1,352	1,062	88.3	18.572	4.22	0.96	5.97	2.71	7.31	4.97	8.45	7.66	9.44	10.70
30043666	12.53		45,108	1,424	1,050	88.5	22.063	4.67	1.05	6.61	2.98	8.09	5.48	9.34	8.44	10.45	11.79
30043667	14.17	51,012	1,818	1,340	88.5	31.762	4.70	1.06	6.65	3.00	8.14	5.52	9.40	8.49	10.51	11.87	

Flange-mounted ZerAx AZL fans with Ø350 hubs and IE3 motors

Item no.	Fan size [mm]	Optimal performance						Total pressure performance indicators									
								200 Pa		400 Pa		600 Pa		800 Pa		1,000 Pa	
		Airflow [m3/s]	Airflow [m3/h]	Total pressure [Pa]	Static pressure [Pa]	Fan eff. [%]	Power input [kW]	Airflow [m3/s]	Power input [kW]	Airflow [m3/s]	Power input [kW]	Airflow [m3/s]	Power input [kW]	Airflow [m3/s]	Power input [kW]	Airflow [m3/s]	Power input [kW]
30043668	Ø900	9.67	34,812	468	329	89.3	5,873	6.27	1.40	8.87	3.97						
30043669		10.44	37,584	543	381	89.3	7,138	6.27	1.40	8.87	3.97						
30043670		11.19	40,284	672	485	89.3	9,439	6.05	1.35	8.55	3.83	10.48	7.03				
30043671		12.25	44,100	737	514	89.3	11,250	6.32	1.42	8.94	4.01	10.95	7.36				
30043672		13.56	48,816	910	637	89.3	15,259	6.29	1.41	8.90	3.99	10.90	7.33	12.59	11.28		
30043673		14.39	51,804	1,057	748	89.3	18,718	6.20	1.39	8.76	3.93	10.73	7.21	12.39	11.10	13.86	15.52
30043674		15.22	54,792	1,189	844	89.3	22,185	6.20	1.39	8.76	3.92	10.73	7.21	12.39	11.10	13.86	15.51
30043675		17.22	61,992	1,479	1,038	89.3	31,172	6.33	1.42	8.96	4.01	10.97	7.37	12.66	11.35	14.16	15.86
30043676		Ø1000	11.52	41,472	386	256	90.6	5,687	8.13	1.79	11.50	5.08					
30043677	12.14		43,704	416	272	90.6	6,263	8.28	1.83	11.71	5.17						
30043678	13.64		49,104	509	327	90.6	8,593	8.43	1.86	11.92	5.26						
30043679	14.38		51,768	605	403	90.6	10,679	8.06	1.78	11.40	5.03	13.96	9.24				
30043680	16.19		58,284	774	518	90.6	15,280	8.16	1.80	11.53	5.09	14.13	9.35				
30043681	17.38		62,568	870	575	90.6	18,340	8.20	1.81	11.60	5.12	14.21	9.41	16.41	14.48		
30043682	18.58		66,888	984	648	90.6	22,112	8.25	1.82	11.67	5.16	14.29	9.47	16.51	14.58	18.45	20.38
30043683	19.61		70,596	1,080	705	90.6	25,754	8.44	1.86	11.94	5.27	14.62	9.68	16.89	14.91	18.88	20.83

Flange-mounted ZerAx AZL fans with Ø350 hubs and IE3 motors (continued)

Item no.	Fan size [mm]	Optimal performance						Total pressure performance indicators									
								200 Pa		400 Pa		600 Pa		800 Pa		1,000 Pa	
		Airflow [m3/s]	Airflow [m3/h]	Total pressure [Pa]	Static pressure [Pa]	Fan eff. [%]	Power input [kW]	Airflow [m3/s]	Power input [kW]	Airflow [m3/s]	Power input [kW]	Airflow [m3/s]	Power input [kW]	Airflow [m3/s]	Power input [kW]	Airflow [m3/s]	Power input [kW]
30043443	Ø560	2.86	10,296	806	725	83.4	3.208	1.45	0.35	2.05	0.98	2.51	1.80	2.89	2.78		
30043444		3.11	11,196	995	899	84.0	4.232	1.37	0.33	1.94	0.93	2.38	1.70	2.75	2.62	3.07	3.66
30043445		3.51	12,636	1,217	1,094	84.3	5.771	1.40	0.33	1.98	0.94	2.43	1.73	2.80	2.66	3.13	3.71
30043446		3.47	12,492	1,503	1,383	85.0	6.901	1.27	0.30	1.79	0.84	2.19	1.55	2.53	2.38	2.83	3.33
30043447		4.03	14,508	1,795	1,634	85.2	9.509	1.32	0.31	1.87	0.88	2.29	1.61	2.65	2.48	2.96	3.47
30043448		4.44	15,984	1,940	1,744	85.0	11.353	1.40	0.33	1.99	0.93	2.43	1.72	2.81	2.64	3.14	3.69
30043450		3.67	13,212	643	560	85.2	3.207	2.02	0.47	2.85	1.34	3.49	2.45				
30043451	Ø630	4.06	14,616	780	678	85.8	4.231	2.02	0.47	2.86	1.33	3.51	2.45	4.05	3.77		
30043452		4.50	16,200	974	849	86.4	5.771	2.01	0.46	2.84	1.31	3.48	2.41	4.02	3.72	4.50	5.19
30043453		4.89	17,604	1,231	1,083	87.0	7.783	1.94	0.45	2.75	1.26	3.36	2.31	3.88	3.56	4.34	4.98
30043454		5.28	19,008	1,403	1,231	87.4	9.505	1.96	0.45	2.78	1.27	3.40	2.33	3.93	3.59	4.39	5.02
30043455		5.64	20,304	1,576	1,379	87.6	11.289	1.98	0.45	2.80	1.28	3.43	2.35	3.96	3.61	4.43	5.05
30043456		6.07	21,852	1,903	1,675	88.0	14.507	1.97	0.45	2.78	1.27	3.41	2.32	3.94	3.58	4.40	5.00
30043457		6.67	24,012	2,256	1,980	88.2	18.813	1.96	0.44	2.77	1.25	3.39	2.30	3.91	3.55	4.38	4.96
30043458		7.00	25,200	2,385	2,082	88.2	20.787	2.03	0.46	2.87	1.30	3.51	2.39	4.05	3.68	4.53	5.14

Bracket-mounted ZerAx AZL fans with Ø350 hubs and IE3 motors

The AMCA performance certified is for installation type D, ducted inlet, ducted outlet.

Item no.	Fan size [mm]	Optimal performance						Total pressure performance indicators										
								200 Pa		400 Pa		600 Pa		800 Pa		1,000 Pa		
		Airflow [m ³ /s]	Airflow [m ³ /h]	Total pressure [Pa]	Static pressure [Pa]	Fan eff. [%]	Power input [kW]	Airflow [m ³ /s]	Power input [kW]	Airflow [m ³ /s]	Power input [kW]	Airflow [m ³ /s]	Power input [kW]	Airflow [m ³ /s]	Power input [kW]	Airflow [m ³ /s]	Power input [kW]	
30043459	Ø710	4.58	16,488	536	455	88.8	3.207	2.76	0.62	3.90	1.76	4.77	3.23	5.51	4.97	6.16	6.95	
30043460		5.00	18,000	659	563	89.4	4.227	2.74	0.61	3.87	1.73	4.74	3.18	5.47	4.90	6.12	6.85	
30043461		5.58	20,088	816	696	89.9	5.766	2.72	0.60	3.85	1.71	4.71	3.14	5.44	4.83	6.08	6.76	
30043462		6.14	22,104	1,018	873	90.4	7.782	2.68	0.59	3.79	1.68	4.64	3.08	5.36	4.74	5.99	6.63	
30043463		6.67	24,012	1,152	981	90.5	9.506	2.74	0.60	3.87	1.71	4.74	3.14	5.48	4.83	6.12	6.75	
30043464		6.39	23,004	1,397	1,240	90.5	10.975	2.42	0.53	3.42	1.51	4.18	2.77	4.83	4.27	5.40	5.96	
30043465		7.83	28,188	1,602	1,366	90.7	15.278	2.73	0.60	3.85	1.70	4.72	3.12	5.45	4.81	6.09	6.72	
30043466		8.08	29,088	1,650	1,399	90.7	16.253	2.75	0.61	3.89	1.71	4.76	3.15	5.50	4.85	6.15	6.78	
30043467		9.08	32,688	1,896	1,579	90.4	20.915	2.89	0.64	4.09	1.81	5.01	3.32	5.79	5.12	6.47	7.15	
30043417		Ø800	6.11	21,996	405	316	89.5	3.293	4.24	0.95	5.99	2.68						
30043468	6.39		23,004	462	365	89.5	3.779	4.11	0.92	5.82	2.59							
30043469	7.44		26,784	609	477	89.5	5.766	4.20	0.94	5.94	2.65	7.27	4.87					
30043470	8.28		29,808	747	584	89.5	7.779	4.23	0.95	5.98	2.68	7.33	4.92					
30043471	8.83		31,788	859	673	89.5	9.509	4.20	0.94	5.94	2.65	7.27	4.88	8.40	7.51			
30043472	9.30		33,480	975	768	89.5	11.281	4.15	0.93	5.87	2.62	7.19	4.82	8.31	7.42	9.29	10.37	
30043473	10.28		37,008	1,204	953	89.5	15.283	4.13	0.92	5.84	2.61	7.15	4.79	8.25	7.38	9.23	10.31	
30043474	11.11		39,996	1,374	1,080	89.5	18.759	4.18	0.93	5.91	2.64	7.23	4.85	8.35	7.46	9.34	10.43	
30043475	11.89		42,804	1,526	1,189	89.4	22.221	4.24	0.95	6.00	2.68	7.35	4.93	8.49	7.58	9.49	10.60	
30043476	12.39		44,604	1,751	1,386	89.5	26.663	4.19	0.94	5.92	2.65	7.25	4.86	8.37	7.49	9.36	10.46	
30043477	Ø900	6.55	23,580	385	283	88.5	3.265	4.62	1.04	6.53	2.95							
30043478		7.78	28,008	525	381	88.5	5.250	4.67	1.05	6.61	2.98							
30043479		8.61	30,996	711	534	88.5	7.784	4.50	1.02	6.36	2.88	7.80	5.28					
30043480		9.30	33,480	807	600	88.5	9.503	4.57	1.03	6.46	2.92	7.91	5.36	9.13	8.25			
30043481		9.44	33,984	949	736	88.4	11.292	4.28	0.97	6.06	2.74	7.42	5.04	8.56	7.76			
30043482		10.41	37,476	1,172	914	88.3	15.273	4.24	0.96	6.00	2.72	7.35	4.99	8.48	7.69	9.48	10.75	
30043483		11.14	40,104	1,351	1,056	88.3	18.739	4.22	0.96	5.97	2.71	7.31	4.97	8.45	7.66	9.44	10.70	
30043484		12.64	45,504	1,421	1,040	88.5	22.218	4.67	1.05	6.61	2.98	8.09	5.48	9.34	8.44	10.45	11.79	
30043485		14.17	51,012	1,818	1,340	88.5	31.762	4.70	1.06	6.65	3.00	8.14	5.52	9.40	8.49	10.51	11.87	
30043486		Ø1000	9.72	34,992	465	324	89.3	5.869	6.27	1.40	8.87	3.97						
30043487	10.53		37,908	540	375	89.3	7.162	6.27	1.40	8.87	3.97							
30043488	11.25		40,500	673	484	89.3	9.495	6.05	1.35	8.55	3.83	10.48	7.03					
30043489	12.30		44,280	736	511	89.3	11.288	6.32	1.42	8.94	4.01	10.95	7.36					
30043490	13.61		48,996	907	631	89.3	15.278	6.29	1.41	8.90	3.99	10.90	7.33	12.59	11.28			
30043491	14.44		51,984	1,055	745	89.3	18.760	6.20	1.39	8.76	3.93	10.73	7.21	12.39	11.10	13.86	15.52	
30043492	15.31		55,116	1,184	836	89.3	22.228	6.20	1.39	8.76	3.92	10.73	7.21	12.39	11.10	13.86	15.51	
30043493	17.22		61,992	1,479	1,038	89.3	31.172	6.33	1.42	8.96	4.01	10.97	7.37	12.66	11.35	14.16	15.86	
30043494	Ø1000		11.58	41,688	396	265	90.6	5.866	8.13	1.79	11.50	5.08						
30043495			12.22	43,992	416	270	90.6	6.306	8.28	1.83	11.71	5.17						
30043496		13.70	49,320	507	324	90.6	8.598	8.43	1.86	11.92	5.26							
30043497		14.47	52,092	621	417	90.6	11.043	8.06	1.78	11.40	5.03	13.96	9.24					
30043498		16.25	58,500	771	513	90.6	15.268	8.16	1.80	11.53	5.09	14.13	9.35					
30043499		17.50	63,000	883	584	90.6	18.733	8.20	1.81	11.60	5.12	14.21	9.41	16.41	14.48			
30043500		18.61	66,996	988	650	90.6	22.220	8.25	1.82	11.67	5.16	14.29	9.47	16.51	14.58	18.45	20.38	
30043501	19.61	70,596	1,080	705	90.6	25.754	8.44	1.86	11.94	5.27	14.62	9.68	16.89	14.91	18.88	20.83		

Bracket-mounted ZerAx AZL fans with Ø350 hubs and IE3 motors (continued)

Item no.	Fan size [mm]	Optimal performance						Total pressure performance indicators											
								200 Pa		400 Pa		600 Pa		800 Pa		1,000 Pa		1,200 Pa	
		Airflow [m3/s]	Airflow [m3/h]	Total pressure [Pa]	Static pressure [Pa]	Fan eff. [%]	Power input [kW]	Airflow [m3/s]	Power input [kW]	Airflow [m3/s]	Power input [kW]	Airflow [m3/s]	Power input [kW]	Airflow [m3/s]	Power input [kW]	Airflow [m3/s]	Power input [kW]	Airflow [m3/s]	Power input [kW]
30041957	Ø250	0.83	2,988	1,297	1,125	81.9	1.460	0.32	0.08	0.45	0.22	0.56	0.41	0.64	0.63	0.72	0.88	0.79	1.15
30041958	Ø280	1.10	3,960	1,255	1,063	84.7	1.806	0.44	0.10	0.62	0.29	0.76	0.54	0.88	0.83	0.98	1.16	1.08	1.52
30041959	Ø315	1.43	5,148	1,178	975	86.9	2.152	0.58	0.13	0.82	0.38	1.01	0.70	1.16	1.07	1.30	1.50		
30041960	Ø355	1.90	6,840	982	760	87.4	2.378	0.80	0.18	1.13	0.52	1.39	0.95	1.61	1.46	1.79	2.05		
30041961	Ø400	2.30	8,280	795	593	87.3	2.341	1.15	0.26	1.63	0.75	2.00	1.38						
30041962		2.70	9,720	1,107	829	87.8	3.816	1.15	0.26	1.62	0.74	1.99	1.36	2.30	2.09	2.57	2.92		
30041963	Ø450	2.80	10,080	614	427	87.0	2.217	1.62	0.37	2.29	1.06	2.80	1.94						
30041964		3.43	12,348	852	572	87.9	3.753	1.66	0.38	2.35	1.07	2.88	1.96	3.32	3.02				
30041965		3.75	13,500	1,074	739	88.3	5.095	1.62	0.37	2.29	1.04	2.80	1.90	3.24	2.93	3.62	4.10		
30041966	Ø500	3.10	11,160	426	276	88.0	1.682	2.12	0.48	3.00	1.36								
30041967		4.01	14,436	644	393	89.4	3.258	2.23	0.50	3.16	1.41	3.87	2.60						
30041968		4.70	16,920	892	547	90.2	5.212	2.23	0.49	3.15	1.40	3.85	2.57	4.45	3.95				
30041969		4.60	16,560	940	610	90.2	5.344	2.17	0.48	3.07	1.36	3.77	2.49	4.35	3.84	4.86	5.37		

Flange-mounted ZerAx AZL fans with Ø160 hubs and IE4 motors

Item no.	Fan size [mm]	Optimal performance						Total pressure performance indicators											
								200 Pa		400 Pa		600 Pa		800 Pa		1,000 Pa		1,200 Pa	
		Airflow [m3/s]	Airflow [m3/h]	Total pressure [Pa]	Static pressure [Pa]	Fan eff. [%]	Power input [kW]	Airflow [m3/s]	Power input [kW]	Airflow [m3/s]	Power input [kW]	Airflow [m3/s]	Power input [kW]	Airflow [m3/s]	Power input [kW]	Airflow [m3/s]	Power input [kW]	Airflow [m3/s]	Power input [kW]
30041970	Ø560	2.80	10,080	993	915	85.7	3.666	1.26	0.29	1.78	0.83	2.18	1.52						
30041971		2.90	10,440	941	858	83.9	3.621	1.34	0.32	1.89	0.90	2.32	1.65						
30042036		3.00	10,800	880	791	82.8	3.550	1.43	0.35	2.02	0.98	2.48	1.80	2.86	2.77				
30042037		3.50	12,600	988	866	82.9	5.347	1.57	0.38	2.23	1.07	2.73	1.97	3.15	3.04				
30042038		3.80	13,680	1,389	1,246	83.9	7.203	1.44	0.34	2.04	0.97	2.50	1.79	2.88	2.75	3.22	3.84	3.53	5.05
30042039		3.50	12,600	979	857	82.1	4.907	1.58	0.39	2.24	1.09	2.74	2.00	3.16	3.08				
30042040		4.20	15,120	1,236	1,061	82.4	7.060	1.69	0.41	2.39	1.16	2.93	2.13	3.38	3.28	3.78	4.58	4.14	6.03
30042041	Ø630	4.30	15,480	1,201	1,017	81.4	7.054	1.75	0.43	2.48	1.21	3.04	2.22	3.51	3.42	3.92	4.78	4.30	6.28
30042042		3.60	12,960	643	563	85.2	3.033	2.01	0.47	2.84	1.33	3.48	2.45						
30042043		4.30	15,480	834	719	86.0	4.694	2.11	0.49	2.98	1.39	3.65	2.54	4.21	3.92				
30042044		4.30	15,480	900	785	86.2	4.929	2.05	0.43	2.89	1.22	3.54	2.25	4.09	3.46	4.58	4.84	5.01	6.36
30042045		4.50	16,200	787	662	84.9	4.620	2.27	0.53	3.21	1.51	3.93	2.78						
30042046		5.40	19,440	999	818	85.6	6.869	2.42	0.56	3.42	1.60	4.18	2.93	4.83	4.51	5.40	6.31		
30042047		5.40	19,440	988	807	84.6	6.892	2.43	0.57	3.44	1.63	4.21	2.99	4.86	4.60	5.43	6.43		
30042048	Ø710	5.20	18,720	719	615	89.6	4.627	2.74	0.61	3.88	1.73	4.75	3.18						
30042049		6.10	21,960	932	789	90.2	6.885	2.83	0.63	4.00	1.77	4.89	3.26	5.65	5.02				
30042052		6.60	23,760	850	683	88.9	6.908	3.20	0.72	4.53	2.04	5.55	3.74	6.40	5.76				
30042054		7.00	25,200	989	801	89.2	8.276	3.15	0.71	4.45	2.00	5.45	3.67	6.30	5.65				
30042055		6.30	22,680	891	739	87.4	7.047	2.98	0.67	4.22	1.90	5.17	3.49	5.97	5.37				
30042056		8.20	29,520	1,041	783	88.5	10.274	3.59	0.81	5.08	2.30	6.23	4.22	7.19	6.49	8.04	9.08		
30042057		8.60	30,960	987	703	87.5	10.432	3.87	0.88	5.47	2.50	6.71	4.60	7.74	7.08				

Bracket-mounted ZerAx AZL fans with Ø350 hubs and IE4 motors

Item no.	Fan size [mm]	Optimal performance						Total pressure performance indicators												
		Air-flow [m ³ /s]	Airflow [m ³ /h]	Total pressure [Pa]	Static pressure [Pa]	Fan eff. [%]	Power input [kW]	200 Pa		400 Pa		600 Pa		800 Pa		1,000 Pa		1,200 Pa		
								Airflow [m ³ /s]	Power input [kW]	Airflow [m ³ /s]	Power input [kW]	Airflow [m ³ /s]	Power input [kW]	Airflow [m ³ /s]	Power input [kW]	Airflow [m ³ /s]	Power input [kW]	Airflow [m ³ /s]	Power input [kW]	
30042058	Ø800	7.80	28,080	698	553	86.4	6.899	4.18	0.97	5.90	2.73	7.23	5.02	8.35	7.73	9.34	10.80	10.23	14.20	
30042060		8.60	30,960	776	599	86.1	8.265	4.37	1.01	6.17	2.87	7.56	5.27	8.73	8.11	9.76	11.34	10.69	14.90	
30042061		7.90	28,440	715	566	89.5	6.922	4.18	0.93	5.91	2.64	7.24	4.85	8.36	7.47	9.34	10.44	10.23	13.72	
30042063		9.10	32,760	955	758	89.5	10.386	4.16	0.93	5.89	2.63	7.21	4.84	8.33	7.44					
30042064		9.50	34,200	901	686	88.5	10.431	4.48	1.01	6.33	2.86	7.75	5.25	8.95	8.09					
30042065		10.00	36,000	850	611	87.6	10.506	5.05	1.15	7.15	3.26	8.75	5.98	10.11	9.21	11.30	12.87	12.38	16.92	
30042069	Ø900	8.33	29,988	500	396	87.7	5.193	5.27	1.20	7.45	3.39	9.13	6.23	10.54	9.59	11.79	13.41	12.91	17.63	
30042071		11.50	41,400	700	503	89.3	9.766	6.14	1.38	8.69	3.89	10.64	7.15	12.29	11.00	13.74	15.38	15.05	20.21	
30041973	Ø1000	14.03	50,508	558	366	90.6	9.407	8.40	1.85	11.88	5.24									
30041974		14.00	50,400	471	280	88.5	8.156	9.14	2.07	12.93	5.84									

Bracket-mounted ZerAx AZL fans with Ø350 hubs and IE4 motors (continued)

Item no.	Fan size [mm]	Optimal performance						Total pressure performance indicators											
		Airflow [m ³ /s]	Airflow [m ³ /h]	Total pressure [Pa]	Static pressure [Pa]	Fan eff. [%]	Power input [kW]	200 Pa		400 Pa		600 Pa		800 Pa		1,000 Pa		1,200 Pa	
								Airflow [m ³ /s]	Power input [kW]	Airflow [m ³ /s]	Power input [kW]	Airflow [m ³ /s]	Power input [kW]	Airflow [m ³ /s]	Power input [kW]	Airflow [m ³ /s]	Power input [kW]	Airflow [m ³ /s]	Power input [kW]
30041975	Ø250	0.83	2,988	1,297	1,125	81.9	1.460	0.32	0.08	0.45	0.22	0.56	0.41	0.64	0.63	0.72	0.88	0.79	1.15
30041976	Ø280	1.10	3,960	1,255	1,063	84.7	1.806	0.44	0.10	0.62	0.29	0.76	0.54	0.88	0.83	0.98	1.16	1.08	1.52
30041977	Ø315	1.40	5,040	1,164	970	86.9	2.081	0.58	0.13	0.82	0.38	1.01	0.70	1.16	1.07	1.30	1.50		
30041978	Ø355	1.90	6,840	983	761	87.5	2.380	0.80	0.18	1.13	0.52	1.39	0.95	1.61	1.46	1.79	2.05		
30041979	Ø400	2.30	8,280	795	593	87.3	2.341	1.15	0.26	1.63	0.75	2.00	1.38						
30041980		2.70	9,720	1,107	829	87.8	3.815	1.15	0.26	1.62	0.74	1.99	1.36	2.30	2.09	2.57	2.92		
30041981	Ø450	2.70	9,720	558	385	86.8	1.942	1.62	0.37	2.29	1.06	2.80	1.94						
30041982		3.43	12,348	852	572	87.9	3.753	1.66	0.38	2.35	1.07	2.88	1.96	3.32	3.02				
30041983		3.75	13,500	1,074	739	88.3	5.093	1.62	0.37	2.29	1.04	2.80	1.90	3.24	2.93	3.62	4.10		
30041984	Ø500	3.10	11,160	426	276	88.0	1.681	2.12	0.48	3.00	1.36								
30041986		4.01	14,436	644	393	89.4	3.257	2.23	0.50	3.16	1.41	3.87	2.60						
30041987		4.70	16,920	892	547	90.2	5.210	2.23	0.49	3.15	1.40	3.85	2.57	4.45	3.95				
30041988		5.00	18,000	1,058	668	90.5	6.501	2.17	0.48	3.07	1.36	3.77	2.49	4.35	3.84	4.86	5.37		

Flange-mounted ZerAx AZN fans with Ø160 hubs and IE4 motors

The AMCA performance certified is for installation type D, ducted inlet, ducted outlet.

Item no.	Fan size [mm]	Optimal performance						Total pressure performance indicators											
								200 Pa		400 Pa		600 Pa		800 Pa		1,000 Pa		1,200 Pa	
		Airflow [m3/s]	Airflow [m3/h]	Total pressure [Pa]	Static pressure [Pa]	Fan eff. [%]	Power input [kW]	Airflow [m3/s]	Power input [kW]	Airflow [m3/s]	Power input [kW]	Airflow [m3/s]	Power input [kW]	Airflow [m3/s]	Power input [kW]	Airflow [m3/s]	Power input [kW]	Airflow [m3/s]	Power input [kW]
30041989	Ø500	2.30	8,280	1,111	1,028	78.6	4,081	0.98	0.25	1.38	0.70	1.69	1.29	1.95	1.99	2.18	2.78		
30041991	Ø560	3.60	12,960	955	826	82.5	6,396	1.65	0.40	2.33	1.13	2.85	2.08	3.29	3.20				
30041994		3.80	13,680	1,393	1,250	83.9	7,229	1.44	0.34	2.04	0.97	2.49	1.78	2.88	2.75	3.22	3.84	3.53	5.05
30041999	Ø630	4.30	15,480	834	720	86.0	4,695	2.11	0.49	2.98	1.39	3.65	2.54	4.21	3.92				
30042000		4.90	17,640	1,117	968	86.8	7,003	2.07	0.48	2.93	1.35	3.59	2.48	4.15	3.82	4.64	5.35		
30042003	Ø710	5.20	18,720	719	615	89.6	4,627	2.74	0.61	3.88	1.73	4.75	3.18						
30042004		6.10	21,960	932	789	90.2	6,886	2.83	0.63	4.00	1.77	4.89	3.26	5.65	5.02				
30042017	Ø800	7.90	28,440	715	566	89.5	6,922	4.18	0.93	5.91	2.64	7.24	4.85	8.36	7.47	9.34	10.44	10.23	13.72
30042019		9.20	33,120	944	742	89.5	10,381	4.23	0.95	5.99	2.68	7.33	4.92	8.47	7.57				
30042025	Ø900	9.20	33,120	578	452	87.9	6,651	5.41	1.23	7.65	3.48	9.37	6.40	10.82	9.85	12.10	13.77	13.26	18.10
30042027		11.94	42,984	726	513	89.3	10,523	6.27	1.40	8.86	3.97	10.85	7.30						

Flange-mounted ZerAx AZN fans with Ø350 hubs and IE4 motors

The AMCA performance certified is for installation type D, ducted inlet, ducted outlet.

Dimensions

AZN for duct installation

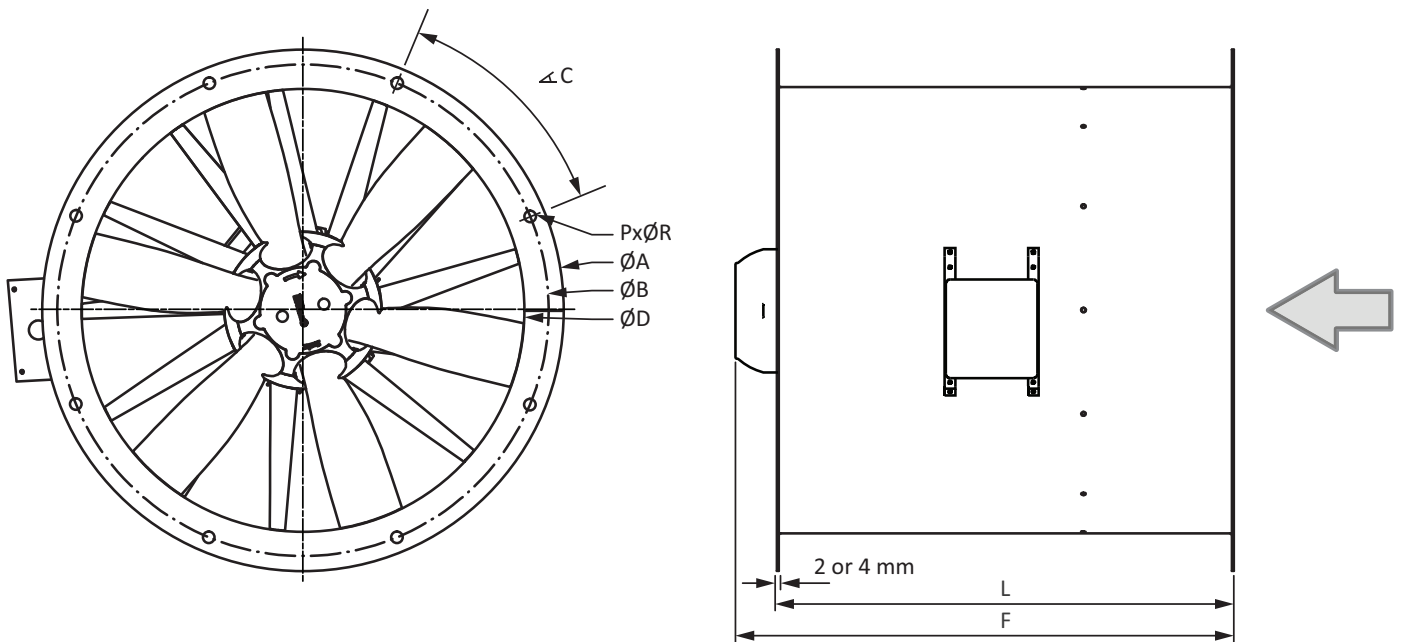

Hub sizes [mm]	ØD [mm]	ØB [mm]	ØA [mm]	C [°]	P	ØR [mm]	Max. weight ² [kg]
Ø160	250	280	310	90	4	10	9
	280	320	350	90	4	10	11.5
	315	355	385	45	8	10	13.5
	355	395	435	45	8	10	15.5
	400	450	480	45	8	12	17.5
	450	500	530	45	8	12	19.5
	500	560	590	30	12	12	21.5
Ø350 ¹	500	560	590	30	12	12	46.5
	560	620	650	30	12	12	50.5
	630	690	720	30	12	12	55.5
	710	770	800	22.5	16	12	61
	800	860	890	22.5	16	12	67
	900	970	995	22.5	16	15	73.5
	1000	1070	1095	22.5	16	15	104
	1120	1190	1215	18	20	15	113
	1250	1320	1345	18	20	15	123
	Ø560 ¹	1000	1070	1100	22.5	16	15
1120		1190	1230	18	20	15	239
1250		1320	1375	18	20	15	239
1400		1470	1540	18	20	15	307
1600		1680	1760	15	24	19	353
1800		1880	1970	15	24	19	383
2000		2080	2170	15	24	19	425

Hub sizes [mm]	Motor sizes	F ³ [mm]	L [mm]
Ø160	71	450	450
	80	450	
	90	450	
	100	527	
	112	574	
Ø350 ¹	90S	452	410
	90L	477	
	100L	514	
	112M	531	
	132S	585	
	132M	623	
	160M	832	
	160L	876	
	180M	898	
	180L	936	
Ø560 ¹	132S	754,5	700
	132M	792,5	
	132M/L	817,5	
	160M	870,5	
	160L	914,5	
	180M	936,5	
	180L	974,5	
	200M	1001,5	
	200L	1039,5	
	225S/M	1338,5	
250S/M	1417,5		
280S/M	1523,5		

1. The AZN ATEX is only available with Ø350 or Ø560 hubs. Refer to AirBox for the ATEX motors.

2. Exclude motors.

3. Values are max. values and for standard motors and may vary depending on motor make. Refer to the technical specifications from AirBox and for the ZerAx Standard Range for specific values.

AZW for heavy duty

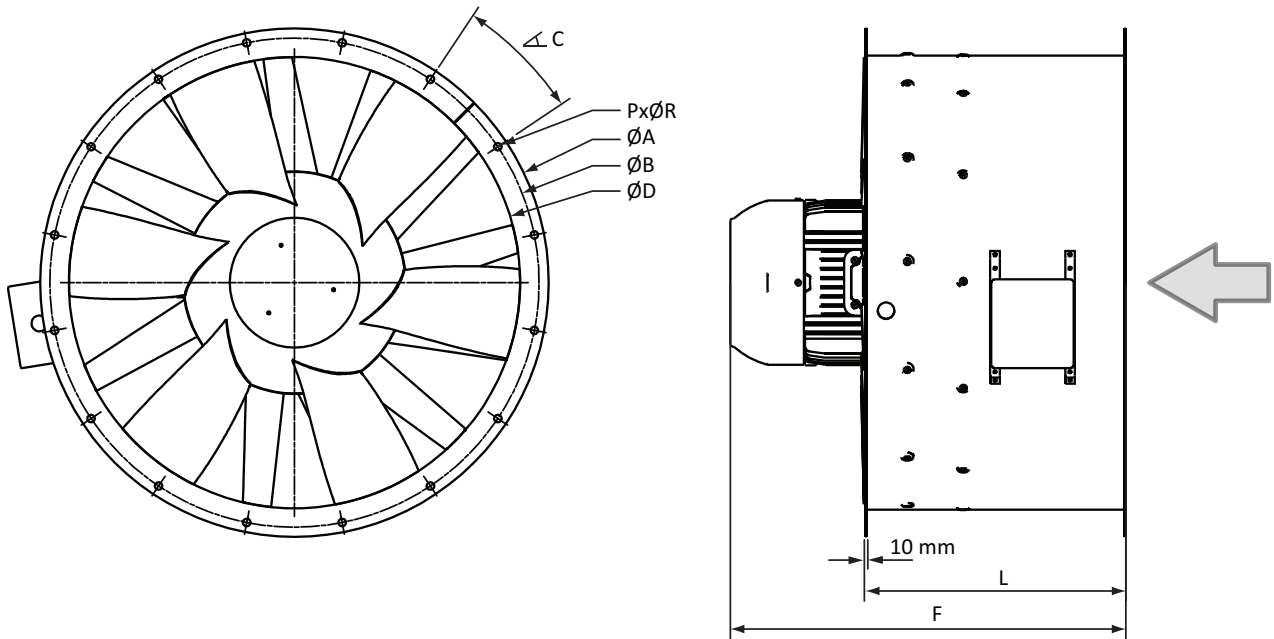

Hub sizes [mm]	ØD [mm]	ØB [mm]	ØA [mm]	C [°]	P	ØR [mm]	Max. weight ² [kg]	
Ø350 ¹	500	551	592	30	12	12	93	
	560	629	672		16	14	105	
	630	698	742		22.5	16	14	117
	710	775	822			16	14	129.5
	800	861	912	15	24	14	144	
	900	958	1012		24	14	160	
	1000	1067	1113		24	14	175	
	1120	1200	1263	11.25	32	18	201	
	1250	1337	1393		32	18	221	
	Ø560	1000	1067	1113	15	24	14	288
1120		1200	1263	11.25	32	18	378	
1250		1337	1393		32	18	411	
1400		1491	1543		32	18	452	
1600		1663	1753	9	40	18	512	
1800		1856	1953		40	18	566	
2000		2073	2153		40	18	619	

Hub sizes [mm]	Motor sizes	F ³ [mm]	L [mm]
Ø350 ¹	90S	452	410
	90L	477	
	100L	514	
	112M	531	
	132S	585	
	132M	623	
	160M	832	
	160L	876	
	180M	898	
	180L	936	
Ø560	132S	754,5	700
	132M	792,5	
	132M/L	817,5	
	160M	870,5	
	160L	914,5	
	180M	936,5	
	180L	974,5	
	200M	1001,5	
	200L	1039,5	
	225S/M	1338,5	
250S/M	1417,5		
280S/M	1523,5		

1. The AZW EX is only available with Ø350 hubs. Refer to AirBox for the marine EX motors.

2. Exclude motors.

3. Values are max. values and for standard motors and may vary depending on motor make. Refer to the technical specifications from AirBox and for the ZerAx Standard Range for specific values.

AZL for free inlet

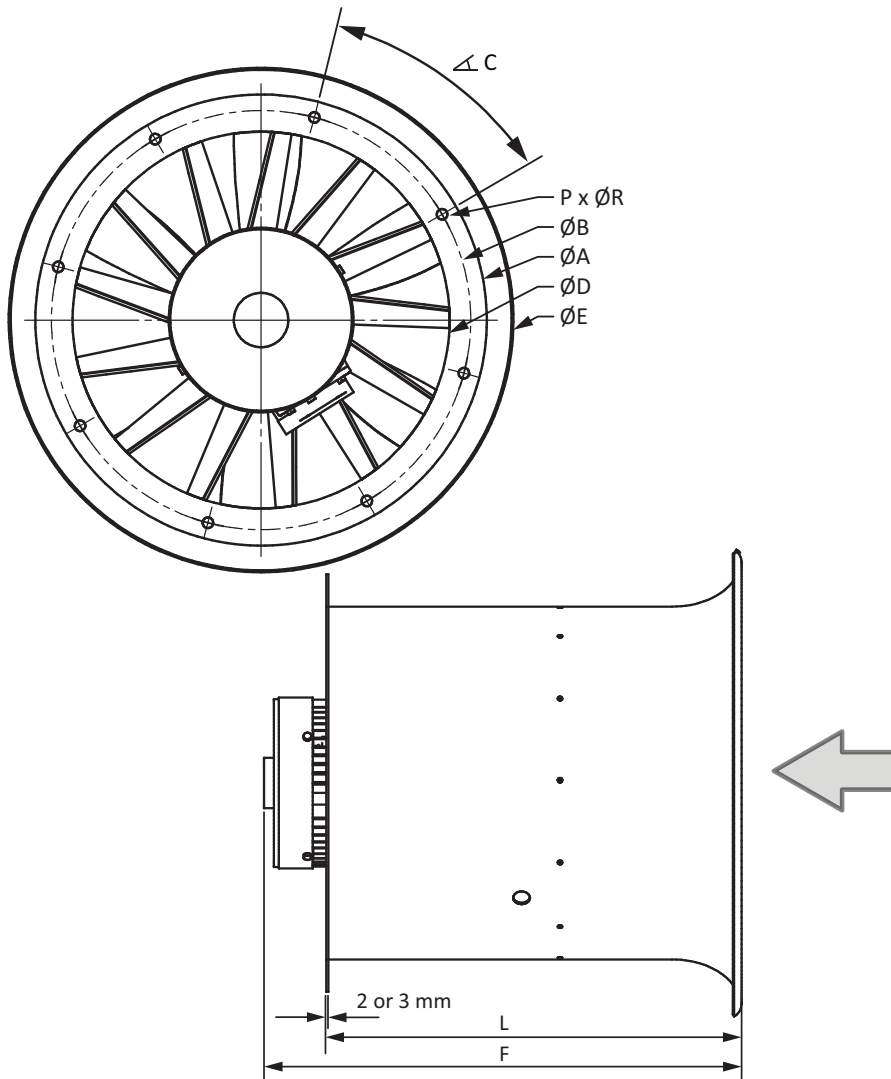

Hub sizes [mm]	ØD [mm]	Motor sizes	F ² [mm]
Ø160	250	80	461
	280	80	467
	315	80	474
		90	521
		100	558
	355	80	482
		90	529
		100	566
	400	80	491
		90	538
		100	575
		112	619
	450	80	501
		90	548
		100	585
		112	629
500	80	511	
	90	558	
	100	595	
	112	639	
500	90		
	100	610	
	112		
	132	673	
	160	930	
	180	990	
560 + 630	90		
	100	630	
	112		
	132	698	
	160	955	
	180	1015	
Ø350	90		
	100	650	
	112		
	132	728	
	160	985	
	180	1045	
900 + 1000	90		
	100	690	
	112		
	132	768	
	160	1025	
	180	1085	

Hub sizes [mm]	ØD [mm]	ØB [mm]	ØA [mm]	ØE [mm]	C [°]	P	ØR [mm]	L [mm]	Max weight ¹ [kg]
Ø160	250	280	310	329	90	4	10	225	7
	280	320	350	369	90	4	10	231	9.5
	315	355	385	416	45	8	10	238	10.5
	355	395	425	470	45	8	10	246	12.5
	400	450	480	530	45	8	12	255	13.5
	450	500	530	597	45	8	12	265	15
	500	560	590	664	30	12	12	275	16
	500	560	590	664	30	12	12	460	36.5
Ø350	560	620	650	753	30	12	12	485	61
	630	690	720	843	30	12	12		72
	710	770	800	949	22.5	16	12	515	58
	800	860	890	1068	22.5	16	12		97
	900	970	1000	1203	22.5	16	15	555	115
	1000	1070	1100	1336	22.5	16	15		130

1. Exclude motors.

2. Values are max. values and for standard motors and may vary depending on motor make. Refer to the technical specifications from AirBox and for the ZerAx Standard Range for specific values.

Fan accessories

The ZerAx accessory programme is wide and makes it possible to customise fan solutions for virtually any purpose and installation conditions. All accessory options are selectable in the AirBox program.

Anti-vibration mounts

The fitting of anti-vibration mounts is an effective way to prevent spreading of vibrations from fan units to the installation environment and vice versa. The kind of mounts depends on the fan size. Smaller and medium fans are typically fitted with cylindrical rubber discs on the support frame or on the mounting plates. Larger fans are fitted with steel springs as rubber discs cannot provide sufficient damping due to heavy weight and low speeds.



Anti-vibration mounts

The anti-vibration mounts are available in different size combinations. Types and sizes are dimensioned by Novenco based on fan type and size, air pressure and accessories.

Fan features	AZN	AZW	AZL
Acoustic diffuser type YAD with or without core	•		•
Acoustic diffuser type YAZ without core	•		•
Fan casing extension ¹	•	•	•
Hub cover	•		•
Inlet cone with wire guard	•	•	
Inlet wire guard	•	•	•
Outlet wire guard	•	•	•
Short diffuser	•		•
Long diffuser	•		•
Extra long diffuser	•		
Double length diffusers ²	•		•
Round-to-square diffuser ⁴	•		
Painted impeller for C4/5 environments	•	•	•
Silencer type YAA with or without core		•	
Silencer type YAH with or without core	•	•	•

1. The fan casing extension is made of 2 mm metallic coated steel sheet and is usually selected for fans where the motors cannot be encased otherwise. It is also referred to as an extension duct.

2. Double length diffusers are two diffusers in series where the connection diameter, ØD, of the second diffuser matches the end diameter, ØD2, of the first diffuser.



AZN with acoustic diffuser type YAZ

Support frames and vertical mounting plates

Support frames are for fan installations where the arrangements become too heavy or where there, for example, is a need for an elevated fan position.

The support frames are of sheet steel and can be fitted with anti-vibration mounts.

Mounting plates for installation on to walls or other plane surfaces are also part of the mounting accessory programme.

Hub covers

A hub cover is a plate that installs in the fan rear on the motor dish

Mounting	AZN	AZW	AZL
Anti-vibration mounting plate	•	•	
Anti-vibration mounts	•	•	
Support frame for horizontal mounting	•		•
Vertical mounting plate	•		•
Connection			
Counter flange	•	•	•
Duct spigots	•	•	•
Flexible connection (PERL / Maritex)	•	•	•
Measuring pipe	•		•
External			
Damper type SBA-SBC	•	•	•
Roof hood type HAN	•		
Roof hood type HAT		•	
Motor			
Frequency converter	•	•	•
Kit for lubrication ³	•	•	•
Low temperature option	•	•	•
Space heater	•	•	•
Thermal protection	•	•	•

3. The kits are available for WEG motor sizes 160, 180 and 200. Smaller sizes are greased for life and bigger sizes are fitted with grease nipples as standard. Refer to the motor manufacturer's documentation.

4. Round-to-square diffusers allow for direct connection to square ducts.

to prevent dust and water from entering the hub. Dust that settles or ice that forms in cavities, can result in impeller imbalance. The covers are available for hub sizes $\varnothing 350$ and $\varnothing 560$ and are recommended in special circumstances.

Inlet cones

Inlet cones screw directly on to the fan flanges to even out the inlet airflow, improve performance and reduce the noise level. All accessories include components necessary for assembly and mounting.

Wire guards for inlet cones and ducts

Novenco wire guards are for mounting on standard temperature and smoke fans with free inlet to prevent contact with the impellers and to stop objects from entering the fans. The guard nets attach with screws to inlet cones or in ducts.

Duct pieces and inlet cones with integrated wire guards for flange mounting are also available.

The wire guards cause a loss of 2% of the total pressure when fitted on inlet cones and a loss of 5% of the dynamic pressure when fitted in ducts.

Spark-proof linings

The linings prevent flying of sparks from blade tips in case these come in contact with the fan casing. The material is aluminium for ATEX and brass for EX fans. Brass executions are primarily for marine environments.

Inspection hatches

The hatches are square holes in the fan casing, which are closed off with metal hatches. The hatches are for verification purposes.

Counter flanges

Counter flanges duplicate the hole patterns of the fan flanges. They are produced in different kinds of materials depending on the intended use. Counter flanges in sheet steel are for welding on to existing ducts to enable fan attachment, while counter flanges in galvanised material are for installation as backing on wall-like surfaces.

Duct spigots

Duct spigots mount on to the fan flanges and allow for connection to ducts. Ducts are fitted to the spigots with clamping rings.

Welding spigots

Welding spigots mount on the fan flanges and allow for connection to ducts. Ducts are welded directly on to these spigots.

Silencers

Silencers have round connection profiles, attenuate noise in installations and are available with or without cores. Versions with cores remove high frequency sounds.

Two silencers can be joined with a standard clamping ring. More than two silencers in series require other measures for joining.

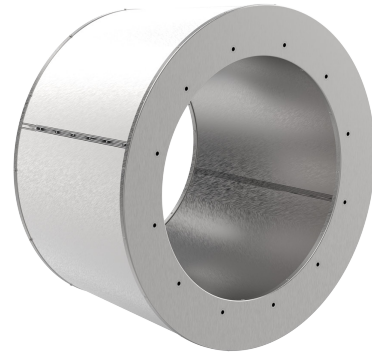

Silencer types YAA-YAH

Diffusers and acoustic diffusers

The diffusers are for use in installations for comfort and industrial ventilation. The basic versions have limited noise reduction capabilities, but smooth airflow, reduce pressure loss and are available in short, long, extra long (AZN) or double lengths. A round-to-square diffuser is also available for the AZN. The acoustic diffusers attenuate noise well and are available with cores for removal of high frequency sounds.

Flexible connections

The flexible material in these connections absorb vibrations from the fans and ducts. The pressure loss is minimal due to the strength and short length of the material. Versions with one or two connection spigots are available.



Flexible connections

Dampers

Dampers shut off, regulate and mix airflows in ventilation systems and air handling installations.

Hoods

Hoods are for roof mounting to prevent wind, rain and objects from entering ventilation systems with subsequent noise-generation and clogging. The design and materials are very durable.

Frequency converters and EC+

Installation of a frequency converter for fan control facilitates optimal operation and minimisation of energy consumption through velocity control of the fan motor. Frequency converters remove the classic limitations caused by fixed net frequencies and are available for both standard temperature and hot smoke fans.

Permanent Magnet (PM) motors in Novenco fans must be connected to frequency converters for power. Direct connection of PM motors, i.e. directly to a power source, invalidates the warranty.

The use of Alternating Current (AC) motors is also possible in connection with frequency converters.

Benefits of frequency-converter fan operation

- Reduction of fan and motor wear through smooth control of starts, accelerations and stops
- Better motor reversal control
- Reduction of harmonics
- Improvement of power factor

- Low noise levels
- Reduction of operating and maintenance costs, i.e. low Total Cost of Ownership (TCO)
- Flexible installation and connection to both new and existing automation systems
- Manual as well as remote operation

The main characteristic and benefit of frequency converter operation is undoubtedly the high energy efficiency. The converter controls the fan motor speed through intelligent frequency management in accordance with operational conditions and user demands.

The total efficiency of a system is, for example, found with the EC+ efficiency equation, which is the basis of the EC+ concept. The concept is the result of a cooperation between Danfoss® and Novenco® Building & Industry A/S for optimisation of fan and ventilation operation with premium-efficiency components. The performance losses in each of the EC+ components are low and ensure a high total system efficiency.

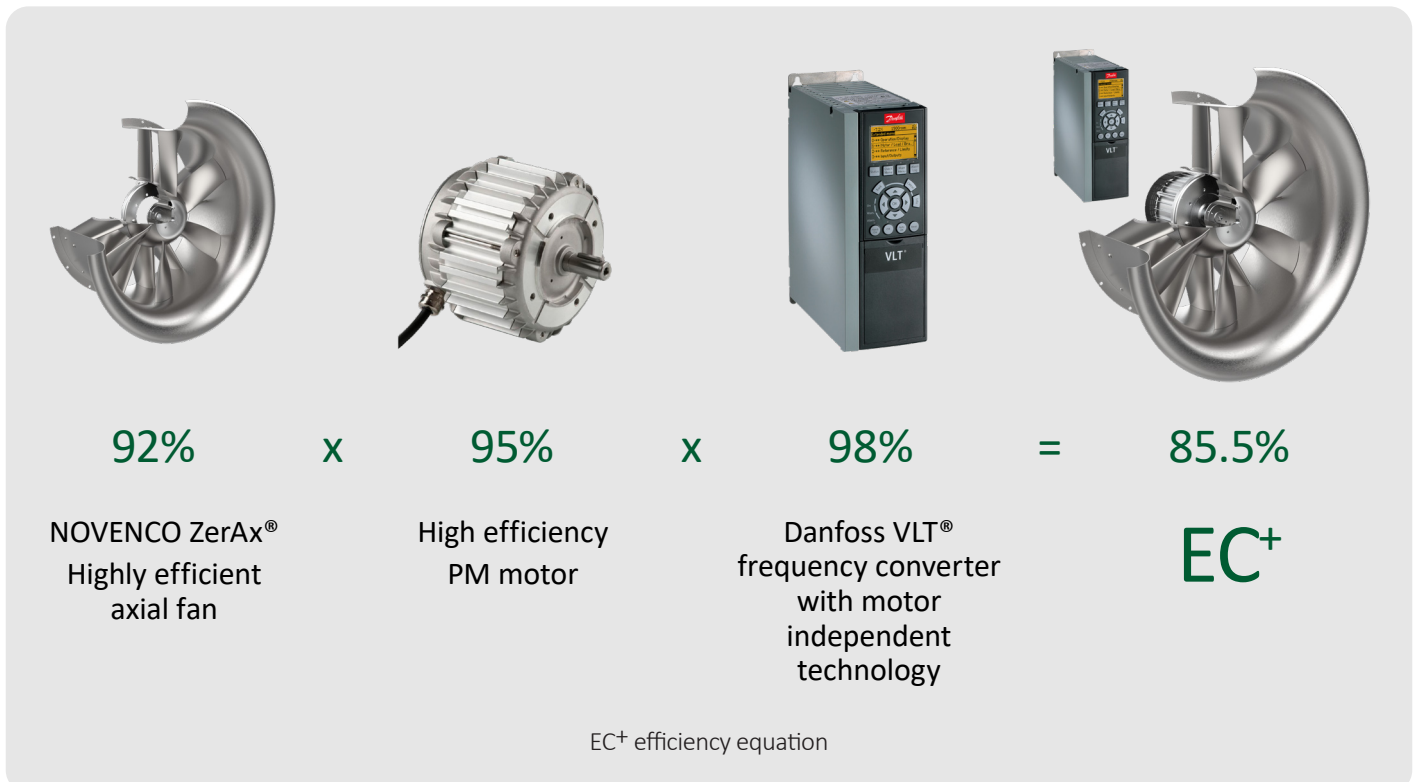

Support frames, diffusers and casing extensions

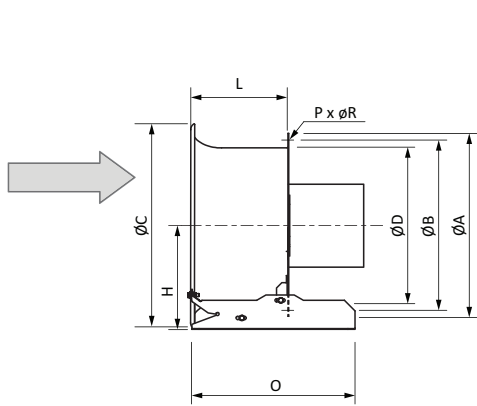

Support frame for AZL with Ø160 hubs

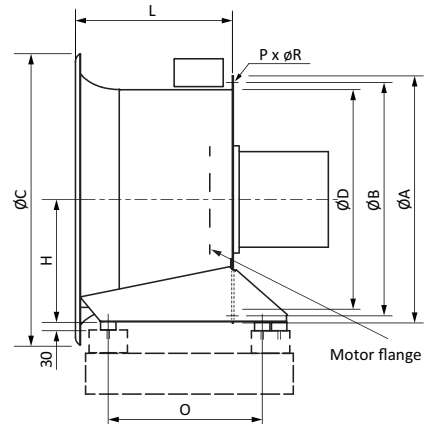

Support frame for AZL with Ø350 hubs

	Installation sizes according to impeller diameters ² [mm]													
	Hub Ø160							Hub Ø350						
	Ø250	Ø280	Ø315	Ø355	Ø400	Ø450	Ø500	Ø500	Ø560	Ø630	Ø710	Ø800	Ø900	Ø1000
ØA	310	350	385	425	480	530	590	590	650	720	800	890	1000	1100
ØB	280	320	355	395	450	500	560	560	620	690	770	860	970	1070
ØC	333	373	420	473	545	600	675	675	753	842	948	1068	1202	1338
ØD	250	280	315	355	400	450	500	500	560	630	710	800	900	1000
O ⁴	290	290	290	290	290	290	290	340	340	340 622	380 632.5	380 631	430 642.5	430 621.5
P	4	8	8	8	8	8	12	12	12	12	16	16	16	16
ØR	10	10	10	10	12	12	12	12	12	12	12	12	15	15
H ⁴	165	185	209	235.2	265.5	299	332	300	301	400.5 400	400.7 400	450.9 450	501 501	550 549
L ⁴	225	231	238	246	255	265	275	460	485	485 485.5	515 516	515 516	555 556	555 556
Weight ¹ [kg]	2.5	2.6	3.7	4	3.7	4.1	3.5	36 52	43 61	50 72	58 84	70 97	80 115	91 130

Support frames for AZL ²

1. Weights exclude fans and motors. For hub sizes Ø350 top values are for fans with 2 mm casings and bottom values are for 3 mm casings. Refer to Novenco AirBox for weights of specific configurations.

2. The width and design of the mounting support construction depend on hub size.

3. The flange standards are according to Eurovent 1/2.

4. For hub size Ø350 the top values are for motor sizes ≤132 and bottom values for motor sizes >132. Motor sizes > 132 are available for fan sizes ≥ 630.



Built-in AZL in AHU section

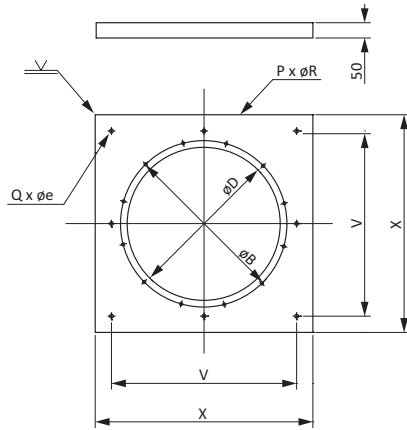

Vertical mounting plate

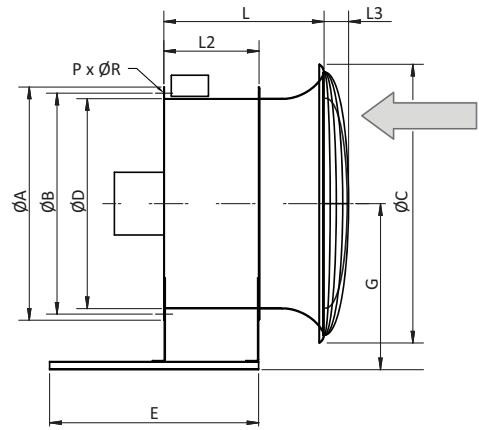

Support frame, inlet cone and wire guard for AZN

		Installation sizes according to impeller diameters ¹ [mm]																							
		Hub Ø160						Hub Ø350						Hub Ø560											
		Ø250	Ø280	Ø315	Ø355	Ø400	Ø450	Ø500	Ø500	Ø560	Ø630	Ø710	Ø800	Ø900	Ø1000	Ø1120	Ø1250	Ø1000	Ø1120	Ø1250	Ø1400	Ø1600	Ø1800	Ø2000	
Vertical mounting plates	ØB	280	320	355	395	450	500	560	560	620	690	770	860	970	1070	1190	1320	1070	1190	1320	1470	1680	1880	2080	
	ØD	250	280	315	355	400	450	510	510	570	640	720	810	910	1010	1130	1260	1010	1130	1260	1410	1610	1810	2010	
	øe	8	8	8	8	12	12	12.5	12.5	12.5	12.5	12.5	12.5	12.5	12.5	12.5	12.5	12.5	12.5	12.5	12.5	12.5	12.5	12.5	
	Q ⁷	8	8	8	8	8	8	4	4	4	4	4	4	4	4	4	4	4	4	4	4	4	4	4	
	P	4	4	8	8	8	8	12	12	12	12	16	16	16	16	20	20	16	20	20	20	24	24	24	
	ØR	10	10	10	10	12	12	12	12	12	12	12	12	12	15	15	15	15	15	15	15	19	19	19	
	V	544	544	544	544	544	544	745	745	805	875	954	1044	1142	1242	1362	1492	1242	1362	1492	1640	1850	1890	2090	
	X	600	600	600	600	600	600	830	830	890	960	1040	1130	1230	1330	1450	1580	1330	1450	1580	1730	1930	1990	2190	
	Weights [kg] ⁵		9.8	9.5	9.1	8.5	8.0	7.2																	
		15.4	14.8	14.2	13.5	12.4	11.2	12.4	13.7	15.2	20.2	22.6	33.6	37.5	42.2	47.6	37.5	42.2	47.6	66.2	77.3	68	80		
Support frames, inlet cones and wire guards for AZN ²	ØA	310	340	385	435	480	530	590	590	650	720	800	890	1000	1100	1220	1360	1100	1220	1360	1510	1760	1922	2170	
	ØB	280	320	355	395	450	500	560	560	620	690	770	860	970	1070	1190	1320	1070	1190	1320	1470	1680	2122	2080	
	ØC	335	375	422	475	536	602	669	669	765	845	952	1060	1205	1338	1505	1569	1338	1505	1569	1757	2007	2257	2508	
	ØD	250	280	315	355	400	450	500	500	560	630	710	800	900	1000	1120	1250	1000	1120	1250	1400	1600	1800	2000	
	E ⁴		900																						
									700	700	700	700	700	700	700	700	700	700	880	880	880	880	880	880	880
								940	940	940	940	940	940	940	940	940	940	940	1500	1500	1500	1500	1500	1500	1500
	P	4	4	8	8	8	8	12	12	12	12	12	16	16	16	16	20	20	16	20	20	20	24	24	24
	ØR	10	10	10	10	12	12	12	12	12	12	12	12	12	12	15	15	15	15	15	15	15	19	19	19
	G	350	365	395	420	395	415	435	435	485	525	575	625	725	785	845	895	812	872	972	1072	1172	1322	1422	
	L	650	650	650	650	655	655	655	615	670	675	675	670	690	710	730	730	1000	1046	1055	1083	1120	1158	1195	
	L2		450																						
L3	31	37	45	57	73	89	60	60	74	92	116	142	90	111	138	138	111	138	138	176	223	280	342		
Total weights [kg] ¹								128	137	145	154	164	179	192	207	221	221	385	423	469	512	573	636	709	
								290	301	318	284	297	314	330	347	364	364	554	590	622	659	707	814	876	
Weights of AZN support frames [kg] ⁶								7.4	8	8.4	9	9.8	11.8	13	14	15	13	14	15	34.5	46.5	n/a	n/a		
		9.4	9.8	10.7	11.2	10.9	11.4	11.4	11	11.6	12	12.6	13.4	15.4	16.6	17.6	18.6	16.6	17.6	18.6	34.5	46.5	n/a	n/a	
								12.2	12.8	13.2	13.8	14.6	16.6	17.8	18.8	19.8	17.8	18.8	19.8	34.5	46.5	n/a	n/a		
							n/a	26	27	27	28	30	31	32	33	33	31	32	33	49	61	150	162		

1. Weights are total weights including motor sizes 132 (top) or 180 (bottom) with lowest rated power and speed.

2. The length of the side members on the support frame depends on the motor size.

3. The flange standards are according to Eurovent 1/2 for AZL and AZN, and DIN 24154 R4 for AZW.

4. For AZN with Ø350 hubs the top values are for motor sizes 90-132 and the bottom values for sizes 132-180. For AZN with Ø560 hubs the top values are for motor sizes 132-200 and the bottom values are for sizes 225-280.

5. Weights exclude fans and motors. Top values are for AZL fans and bottom values are for AZN.

For heavy constructions the vertical mounting plates are reinforced with two rails. Refer to Novenco AirBox or contact Novenco.

6. In cells with multiple values, top values are for fans without ext. ducts, 2nd for Ø410 ext. ducts, 3rd for Ø550 and 4th for Ø850 ext. ducts.

Refer to Novenco AirBox for specific weights.

7. Vertical mounting plates for hub sizes Ø350 and Ø560 have a fixation bolt in each corner.

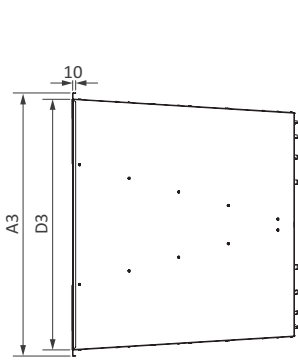

Round-to-square diffuser

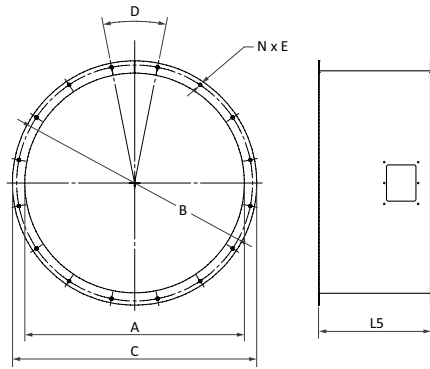

Fan casing extension ⁶

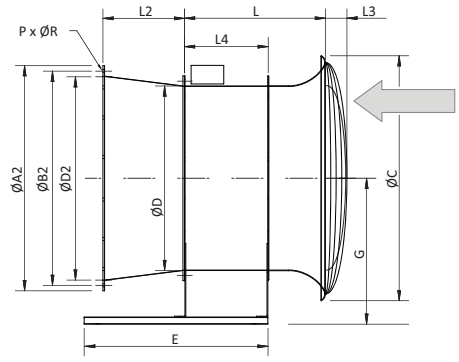

Support frame, inlet cone and round diffuser for AZN

		Installation sizes according to impeller diameters [mm] ⁷																								
		Hub Ø160							Hub Ø350							Hub Ø560										
		Ø250	Ø280	Ø315	Ø355	Ø400	Ø450	Ø500	Ø500	Ø560	Ø630	Ø710	Ø800	Ø900	Ø1000	Ø1120	Ø1250	Ø1000	Ø1120	Ø1250	Ø1400	Ø1600	Ø1800	Ø2000		
AZN with support frame, inlet cone, diffuser and wire guard ²	Dimensions	ØD	250	280	315	355	400	450	500	500	560	630	710	800	900	1000	1120	1250	1000	1120	1250	1400	1600	1800	2000	
		ØD2 ⁵	279	314	354	399	449	499	559	559	630	710	800	900	1000	1120	1250	1400	1120	1250	1400	1600	1800	2000	n/a	
		D3	n/a							802	902	1006	1124	n/a												
		ØA2 ⁵	340	375	415	470	520	580	640	660	730	810	810	888.5	1010	1103	1223	1363	1513	1223	1363	1513	1723	1923	2125	2365
			375	415	470	520	580	640	710	710	810	810	1002	1102	1222	1223	1363	1513	1723	1363	1513	1723	1923	2123	n/a	n/a
		A3	n/a							842	942	1046	1164	n/a												
		ØB2 ⁵	320	355	395	450	500	560	620	620	690	770	770	860	970	1070	1190	1320	1470	1190	1320	1470	1680	1880	2080	2320
			355	395	450	500	560	620	690	690	770	770	860	970	1070	1190	1320	1470	1680	1320	1470	1680	1880	2080	n/a	n/a
		ØC	375	375	422	475	536	602	669	669	765	845	952	1060	1205	1338	1505	1569	1338	1505	1569	1757	2007	2257	2508	
		L	661	n/a	650	n/a	655	n/a	655	615	670	675	675	670	690	710	756	765	1000	1046	1055	1083	1120	1158	1195	
		L2 ⁵	125	140	157.5	175	200	225	250	250	280	315	355	400	400	500	560	600	500	560	600	800	800	900	1000	
			250	280	315	355	400	450	500	500	560	630	710	800	900	1000	1100	1400	1000	1100	1400	1600	1700	1900	2120	
		L3	n/a	45	n/a	73	n/a	60	60	74	92	116	142	90	111	138	138	111	138	138	138	176	223	280	342	
		L4	450																							
	E ⁴	n/a							1000			1300			1600			2100			2900					
	P ⁵	4	8	8	8	8	12	12	12	12	12	16	16	16	20	20	20	20	20	20	24	24	24	32		
		8				12					16	20	20	24	24	24	24	24	24	24	24	24	24	32		
	ØR ⁵	10	10	10	12	12	12	12	12	12	12	12	12	15	15	15	15	15	15	15	19	19	19	19		
				12							15	15	15	15	15	15	15	15	15	19	19	19	19			
	G	350	n/a	395	n/a				433	483.5	523.5	573	623	723.5	783	843.5	893.5	812	872	972	1072	1172	1322	1422		
Weights of diffusers [kg]		Short	n/a				6.9	6.9	8.4	10.3	12.7	15.9	33	40	48	57	40	48	57	77	86	110	133			
		Long	4.6	5.7	7.1	8.9	11.1	13.7	16.9	16.9	20.9	22.9	n/a		52	62	74	102	62	74	102	123	139	246	300	
		Round-square	n/a						26	32	40	49	n/a													
		Extra long	n/a						—	—	47.2	62.4	77.3	n/a												
Fan casing extensions		A	250	280	315	355	400	450	500	500	560	630	710	800	900	1000	1120	1250	1000	1120	1250	1400	1600	1800	2000	
		B	280	320	355	395	450	500	560	560	620	690	770	860	970	1070	1190	1320	1070	1190	1320	1470	1680	1880	2080	
		C	310	350	385	435	480	530	590	590	650	720	800	890	1000	1100	1220	1350	1100	1220	1350	1540	1760	1916	2180	
		L5 ¹	410 or 550							410 or 850																
		D	90	90	45	45	45	45	30	30	30	30	22.5	22.5	22.5	22.5	18	18	22.5	18	18	18	15	15	15	
		E	10	10	10	10	12	12	12	12	12	12	12	12	15	15	15	15	15	15	15	15	19	19	19	
		N	4	4	8	8	8	8	12	12	12	12	16	16	16	16	20	20	16	20	20	20	24	24	24	
		Weights ³ [kg]	n/a				12.4	13.8	15.5	17.5	19.6	22.3	24.8	27.7	30.9	49.5	55.4	63.1	70.6	81.3	91.4	101.5	151	169.8	188.6	
			n/a				15.9	17.7	19.9	22.4	25.2	28.6	31.7	35.5	40.0	93.1	104.2	117.6	131.6	151	169.8	188.6				

- Extensions for fans with Ø160 or Ø350 hubs are available in two lengths. For fans with Ø560 hubs they are made in a short version for motor sizes <= 200 and a long version for larger motors or casing thicknesses of 10 mm.
- The length of the side members on the support frame depends on the motor size.
- Weights for Ø350 hubs for casing extension lengths L5 = 410 (top) and for lengths L5 = 850 (bottom). Weights for Ø560 hubs for casing extension lengths L5 = 410 (top) and for lengths L5 = 850 (bottom).

- Lengths for Ø560 hubs with or without short extensions (top), with long extensions (middle) and with acoustic diffusers (bottom).
- Single values cover all diffusers. Two values mean short (top), and long and extra long (bottom). Three values mean short (top), long (middle) and extra long (bottom).
- Extension ducts with inspection hatch is limited to duct diameters Ø500 to Ø1250.
- Cells with 'n/a' mean that the accessories are unavailable. A dash means that data is unavailable at the time of publication.

Wire guards, cones and flanges

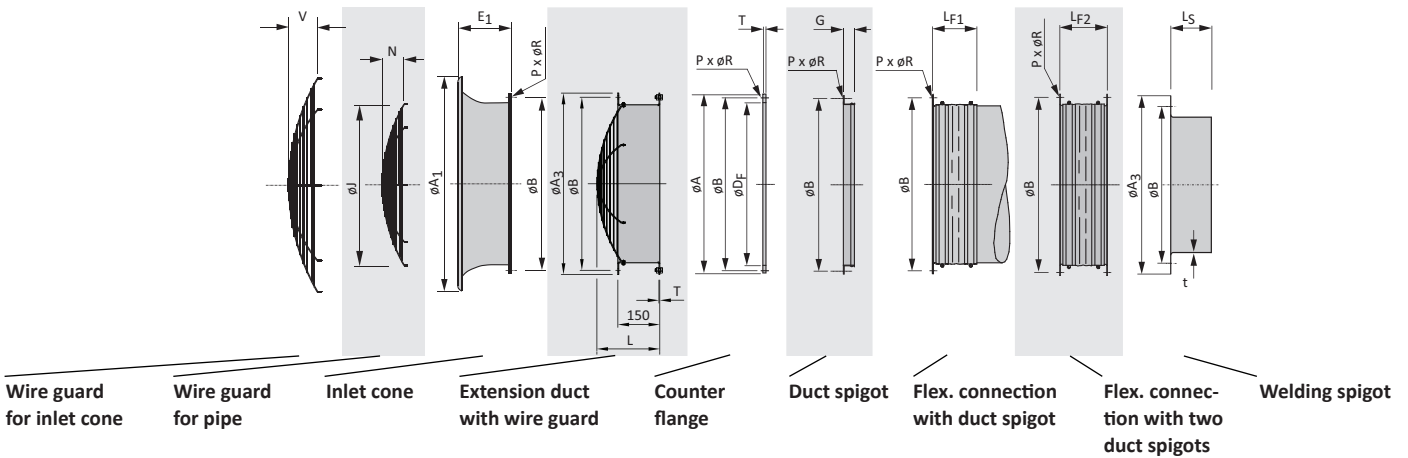

		Installation sizes according to impeller diameters [mm]																		
		Ø250	Ø280	Ø315	Ø355	Ø400	Ø450	Ø500	Ø560	Ø630	Ø710	Ø800	Ø900	Ø1000	Ø1120	Ø1250	Ø1400	Ø1600	Ø1800	Ø2000
Wire guard for inlet cone	V	31	—	45	—	73	—	60	69	87	111	137	85	106	133	133	171	218	275	337
	Weight [kg]	0.1	—	0.2	—	0.3	—	0.5	0.6	0.8	0.9	1.1	2.5	3.0	3.6	3.6	4.2	5.7	6.6	7.8
Wire guard for pipe	N	19	—	29	—	43	—	68	88	55	69	87	111	137	85	106	133	171	218	275
	ØJ	246	—	310	—	396	—	496	556	626	706	796	896	996	1114	1244	1394	1594	1794	1994
	Weight [kg]	0.1	—	0.1	—	0.2	—	0.3	0.3	0.5	0.6	0.8	0.9	1.1	2.5	3.0	3.6	4.2	5.7	6.6
Inlet cone ¹	E ₁	200	200	200	200	205	205	205	260	265	265	260	280	300	325	355	383	420	458	495
	ØA ₁	335	375	422	475	536	602	669 675	760	840	947	1055	1200	1333	1500 1520	1650	1800	2000	2252	2503
	Weight [kg]	3.2	3.6	4.2	4.9	5.8	6.7	7.7	17	19	22	26	32	38	45	51	57	66	130	155
Extension duct with wire guard	L	—	—	340	—	—	—	478	498	465	479	497	521	687	635	656	543	581	1125	1187
	ØA ₃	—	350	—	425	490	540	590	650	720	800	890	1000	1100	1220	1350	1540	1760	1970	2170
	ØB	280	320	355	395	450	500	560	620	690	770	860	970	1070	1190	1320	1470	1680	1880	2080
Counter flange	T	—	—	—	2	2	—	4	4	4	4	4	8	8	8	8	8	8	8	8
	ØD _f	260	290	325	365	410	460	510	570	640	720	810	910	1010	1130	1260	1410	1610	1810	2010
	Weight [kg]	—	3.8	—	5.6	—	9.1	2.2	2.4	2.7	3.0	3.4	8.5	9.4	10.2	12.2	14.2	17.2	22	24
Duct spigot	G	55	55	55	55	55	55	55	55	55	55	55	85	85	85	85	85	85	85	85
	Weight [kg]	1.0	1.2	1.4	1.6	1.8	2.1	2.4	2.7	3.1	3.5	3.9	5.9	6.6	7.4	8.6	9.6	11.3	12.7	14.1
Flexible connection	L _{F1}	Min. 65 mm - max. 100 mm									Min. 110 mm - max. 175 mm									
	Weight w. 1 spigot [kg]	1.3	1.7	2.3	3.0	3.5	3.8	4.3	5.0	7.8	8.9	10.0	11.6	13.1	20	18	20			
	L _{F2}	Min. 120 mm - max. 145 mm									Min. 210 mm - max. 250 mm									
	Weight w. 2 spigots [kg]	2.3	3.0	4.2	5.5	6.2	6.9	7.8	8.8	13.7	15.5	17.4	20.2	22.7	26.6	31	34			
Welding spigots ²	L _S	100	100	100	100	100	100	120	120	120	120	120	150	150	150	150	150			
	t	4	4	4	4	4	4	6	6	6	6	6	6	6	6	6	6			
	ØA3	310	385	480	590	650	720	800	890	1000	1100	1220	1360	1510	1720					
	Weight [kg]	3.1	3.9	5.4	6.7	7.5	15.0	16.9	19.0	21.4	29.0	32.4	36.2	40.5	46.3					

Values for ØA and ØR are in section "Dimensions" on page 15.

1. In cells with two values the bottom value is for AZW.

2. ØB is identical to ØB for extension ducts with wire guards.

Silencers, hoods and dampers

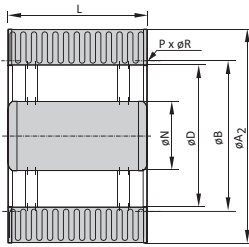

Silencer type YAH

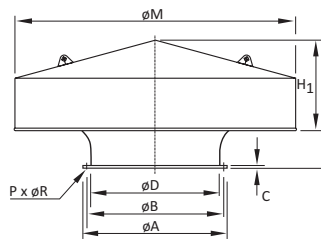

Hood type HAN

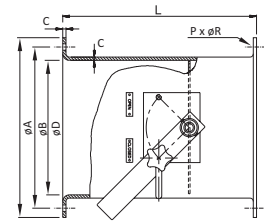

Damper type SBC

		Installation sizes according to impeller diameters [mm]																		
		Ø250	Ø280	Ø315	Ø355	Ø400	Ø450	Ø500	Ø560	Ø630	Ø710	Ø800	Ø900	Ø1000	Ø1120	Ø1250	Ø1400	Ø1600	Ø1800	Ø2000
All	ØD	250	280	315	355	400	450	500	560	630	710	800	900	1000	1120	1250	1400	1600	1800	2000
	ØB	280	320	355	395	450	500	560	620	690	770	860	970	1070	1190	1320	1470	1680	1880	2080
	ØA	310	350	385	425	480	530	590	650	720	800	890	1000	1100	1220	1360	1510	1720	1922	1880
	P	4	4	8	8	8	8	12	12	12	16	16	16	16	20	20	20	24	24	24
	ØR	10	10	10	10	12	12	12	12	12	12	12	15	15	15	15	15	19	19	19
Silencers type YAH	L	250	280	315	355	400	450	500	560	630	710	800	900	1000	1120	1250	1400	1600	1800	2000
	ØN	125	—	160	—	200	—	250	280	315	355	400	450	500	560	578	578	578	578	578
	ØA ₂	463	495	526	570	614	665	715	775	845	925	1015	1115	1215	1335	1463	1613	1813	2013	2213
	ØR	M8	—	M8	—	M10	—	M10	M10	M10	M10	M10	M12	M12	M12	M12	M12	M16	M16	M16
	Weight without core [kg]	6.2	—	8.9	—	12.5	—	19.1	22.8	27.6	33.8	41.3	50.6	61.1	74.5	122	148	188	270	327
Weight w/ core [kg]	7.9	—	11.5	—	16.8	—	26.5	32.8	40.8	52.1	69.2	86.8	110	134	184	220	277	351	417	
Hoods type HAN	H	361	—	412	—	476	—	540	641	694	744	811	868	890	1140	1252	1402	1602	—	—
	H ₁	180	—	228	—	290	—	364	405	450	506	569	645	710	800	853	983	1153	—	—
	ØM	598	—	724	—	906	—	1106	1266	1406	1586	1766	2016	2236	2436	2810	3110	3510	—	—
	C	2.5	—	2.5	—	3	—	3	3	3	3	3	3	3	3	4	4	4	—	—
	Weight [kg]	13	—	19	—	40	—	58	79	97	120	151	206	250	313	625	776	1020	—	—
Dampers type SBC	L	360	—	400	—	520	—	560	620	670	730	810	910	1010	1130	1250	1400	—	—	—
	C	2	—	2	—	3	—	3	3	3	3	3	3	4	4	5	6	—	—	—
	Weight [kg]	9.5	—	12.5	—	24	—	32	41.5	49	63	86	107	149	183	274	386	—	—	—

Technical data for silencer YAH

YAH- Pressure loss

Without core: Insignificant

With core: $0.2 \times p_{dF}$

Two YAH in series: $0.35 \times p_{dF}$ (dynamic pressure)

Inlets on AZN-AZW use silencers without cores.

Example

YAH-800 with core

Conditions: Airflow rate, $q_v = 5 \text{ m}^3/\text{s}$; Air speed,

inlet = 10 m/s ; $P_{dF} = 60 \text{ Pa}$

Pressure loss: $0.2 \times 60 \text{ Pa} = 12 \text{ Pa}$

Average values for sound attenuation

Type	Octave band [Hz]							
	63	125	250	500	1k	2k	4k	8k
Without core [dB]	0	1	10	13	11	9	7	7
With core [dB]	2	4	10	17	17	15	12	11

Acoustic diffusers

Acoustic diffusers are an effective and easy way of attenuating fan noise. Diffusers without cores are suitable for simple attenuation while diffusers with cores are for removal of high frequencies as well.

All diffusers may be mounted directly on the fan casing flanges. Diffusers with relatively large cores, may require casing extensions to be fitted between the fans and diffusers. These diffusers should be supported separately at installation.

With one exception all acoustic diffusers are type YAD. For fan size $\varnothing 1800$ with a diffuser without core the diffuser is type YAZ.

Environment

The diffusers are intended for temperatures between -40 and $+120$ °C.

The basic versions are designed to operate in corrosion class C3. Refer to DS/EN ISO 12944.

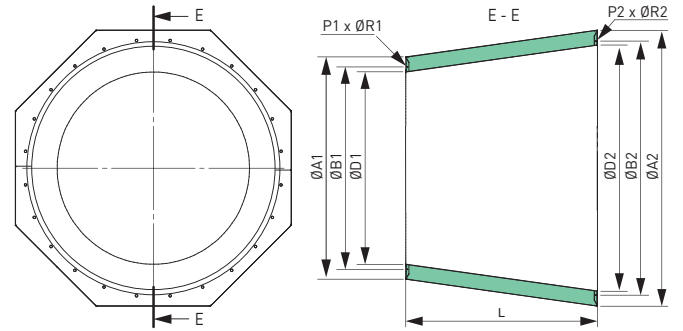

Type YAZ without core

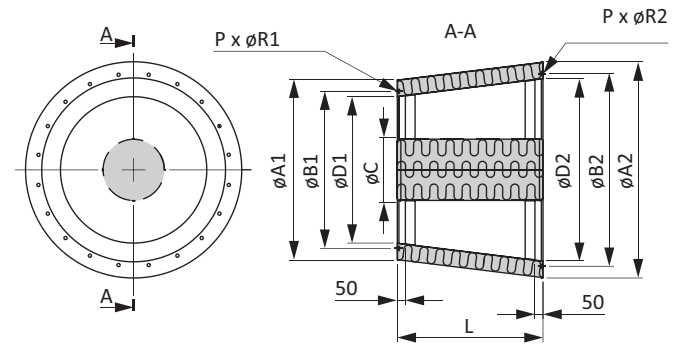

Type YAD with core

Sizes	ØCore [mm]	Fan size [mm]				Fan size [mm]				L [mm]	Weights [kg]	
		ØA1	ØB1	ØD1	P1 x ØR1	ØA2	ØB2	ØD2	P2 x ØR2		with cores ²	without cores
250	160	463	280	253	4 x M8	524	355	318	8 x M8	250	12	n/a
280		491	320	283	4 x M8	564	395	358	8 x M8	280	15	n/a
315		524	355	318	8 x M8	612	450	404	8 x M8	315	18	n/a
355		564	395	358	8 x M10	663	500	454	8 x M10	355	20	n/a
400		612	450	404	8 x M10	716	560	504	12 x M10	400	23	n/a
450		663	500	454	8 x M10	773	620	564	12 x M10	450	27	n/a
500	330	716	560	504	12 x M10	846	690	634	12 x M10	500	31	25
500		700	560	504	12 x M10	830	690	634	12 x M10	500	40	25
560	380	776	620	564	12 x M12	926	770	714	16 x M10	560	47	30
630		846	690	634	12 x M10	1011	860	804	16 x M10	630	56	37
710		926	770	714	16 x M10	1116	960	904	16 x M12	710	73	45
800		1016	860	804	16 x M10	1216	1070	1004	16 x M12	800	87	55
900	578	1116	970	904	16 x M12	1336	1190	1124	20 x M12	900	116	68
1000		1216	1070	1004	16 x M12	1466	1320	1254	20 x M12	1000	157	83
1120		1333	1190	1124	20 x M12	1613	1470	1404	20 x M12	1120	154	100
1250		1466	1320	1254	20 x M12	1816	1680	1604	24 x M12	1250	198	123
1400		1613	1460	1404	20 x M12	2013	1880	1804	24 x M12	1400	274	158
1600		1816	1680	1604	24 x M12	2216	2080	2004	24 x M12	1600	320	192
1800	578	2016	1870	1804	24 x M12	2416	2284	2204	24 x M12	1800	482	390 ¹
2000		2216	2070	2004	24 x M12	2616	2484	2404	24 x M12	2000	582	480

1. The acoustic diffuser size $\varnothing 1800$ is type YAZ.

2. Values are maximum values.

Attenuation values for YAZ without cores

External diameters	Hub diameters	Octave band [Hz]							
		63	125	250	500	1k	2k	4k	8k
1800	560	1	3	8	6	5	4	4	4
2000		1	3	8	6	5	4	4	4

Dimensions are in mm. Attenuation values are in dB.

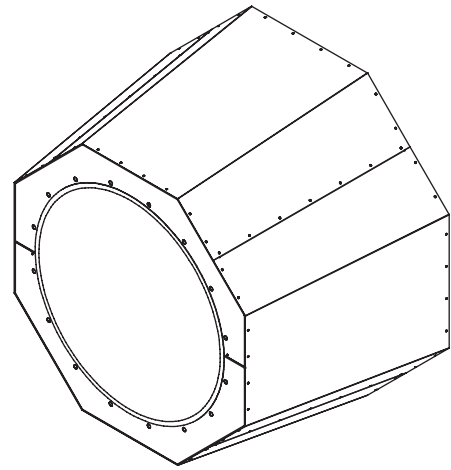

Acoustic diffuser type YAZ without core

Attenuation values for YAD with and without cores

External diameters	ØHub	ØCore	with cores								
			Octave band [Hz]								
			63	125	250	500	1k	2k	4k	8k	
250	160	160	1	1	2	9	11	11	8	5	
315			1	1	2	9	11	11	8	5	
400			0	2	3	12	11	11	7	4	
500			0	1	4	10	12	10	6	4	
400		230	0	2	2	11	14	13	10	6	
500		230	0	2	9	12	12	12	8	5	
		280	0	2	2	12	15	15	11	7	
		330	0	2	3	15	18	18	13	8	
500		330	0	2	3	15	18	18	13	8	
560		350	380	0	2	3	15	19	18	14	8
630	0			2	11	15	15	15	11	6	
710	0			1	5	14	16	13	9	6	
800	1			3	8	16	15	11	7	6	
900	0		1	9	16	15	11	7	5		
1000	1		3	7	14	11	8	6	6		
1120	403		403	1	3	7	14	11	8	6	5
1250				2	2	7	9	10	7	6	5
1000				0	4	9	19	18	13	9	7
1120	560		578	0	1	11	19	17	13	8	5
1250		1		4	8	16	13	9	7	6	
1400		2		3	8	10	11	8	6	5	
1600		2		3	8	9	10	8	6	5	

Dimensions are in mm. Attenuation values are in dB.

External diameters	ØHub	ØCore	without cores								
			Octave band [Hz]								
			63	125	250	500	1k	2k	4k	8k	
250	160	160	1	0	2	8	5	1	1	2	
315			1	0	2	8	5	1	1	2	
400			0	0	3	11	6	1	1	1	
500			0	1	4	11	7	3	3	2	
400		230	0	0	2	10	8	3	3	3	
500		230	0	0	9	11	7	3	2	2	
		280	0	0	2	11	9	5	4	4	
		330	0	0	3	14	12	8	6	5	
500		330	0	0	3	14	12	8	6	5	
560		350	380	0	0	3	14	13	8	7	5
630	0			1	11	13	9	6	4	3	
710	0			1	5	15	11	6	5	4	
800	0			3	8	16	12	6	5	4	
900	0		1	9	16	9	6	4	3		
1000	1		3	7	14	6	3	4	4		
1120	403		403	1	3	7	11	6	4	4	4
1250				1	2	7	5	4	4	4	3
1000				0	4	9	19	14	8	6	5
1120	560		578	0	1	11	19	12	8	5	4
1250		1		4	8	13	7	5	5	5	
1400		1		3	8	6	5	5	5	4	
1600		1		3	8	6	5	4	4	4	

Calculation examples

Basis

The basis for the calculation of solutions is the arrangements C and D.

Installing a fan with free outlet (arr. C) causes loss of the entire velocity energy. However, fitting a diffuser on the outlet side lowers the outlet velocity, whereby some of the dynamic pressure loss is recovered as static pressure. Hence, the energy consumption of the fan is reduced. Novenco diffusers are designed to achieve optimal recovery of the dynamic energy.

A-factor

This is a loss factor, which is used if the fan is used with free outlet (arrangement C). It is related to the speed loss (Δp_d) which results from the difference in air speed between the net inlet area and the total outlet area.

The effect of the a-factor is reduced if a diffuser is mounted on the outlet side. The AirBox program compensates for the a-factor when the fan outlet is to a duct or as free outlet.

For fans with duct connections on the outlet and otherwise unchanged dimensions (arr. B and D) the a-factor is included in the performance data and no correction is necessary.

Formulas for pressure

$$\begin{aligned}
 p_{tF} &= p_{t2} - p_{t1} \\
 &= p_{s2} + p_{d2} - (p_{s1} + p_{d1}) \\
 &= (p_{s2} - p_{s1}) + (p_{d2} - p_{d1}) \\
 p_{sF} &= p_{tF} - p_{dF} \text{ (Definition)}
 \end{aligned}$$

Designations	Symbols	Units	Formula
Mass flow	q_m	kg/s	
Air quantity, airflow	q_v	m ³ /s	$\frac{q_m}{\rho}$
Inlet diameter	D_1	mm	
Outlet diameter	D_2	mm	
Density	ρ	kg/m ³	
Flow area	A	m ²	
Mean speed of plane	c_x	m/s	$\frac{q_v}{A_x}$
Static pressure of plane	p_{sx}	Pa	
Dynamic pressure of plane	p_{dx}	Pa	$0.5 \rho \times c^2$
Total pressure of plane	p_{tx}	Pa	$p_{sx} + p_{dx}$
Total pressure of fan	P_{tF}	Pa	
Dynamic pressure of fan	P_{dF}	Pa	$0.5 \rho \times c_2^2$
Static pressure of fan	P_{sF}	Pa	$P_{tF} - P_{dF}$
System loss	p_t	Pa	
Power consumption	P	kW	
Correction factor	a		

The fan inlets are designated with sub-index 1 and the outlets with sub-index 2.

Arr. A — free inlet and outlet

$$p_{sF} = p_{s2} - p_{t1}$$

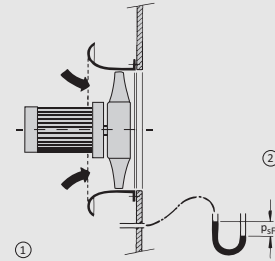

Arr. B — free inlet and duct on outlet

$$\begin{aligned}
 p_{tF} &= p_{t2} - p_{t1} \\
 &= (p_{s2} + p_{d2}) - (p_{s1} + p_{d1})
 \end{aligned}$$

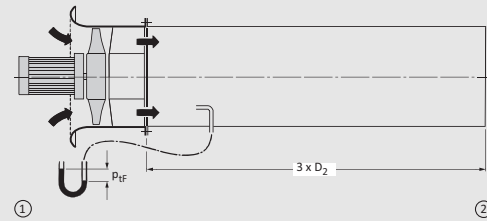

Arr. C — Duct on inlet and free outlet

$$\begin{aligned}
 p_{tF} &= p_{t2} - p_{t1} \\
 &= p_{s2} + a \times p_{d2} - (p_{s1} + p_{d1})
 \end{aligned}$$

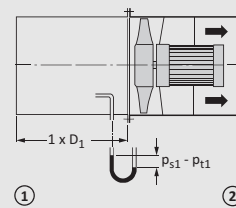

Arr. D — Duct on inlet and outlet

$$\begin{aligned}
 p_{tF} &= p_{t2} - p_{t1} \\
 &= (p_{s2} - p_{s1}) + (p_{d2} - p_{d1})
 \end{aligned}$$

If $p_{d2} = p_{d1}$; then $p_{tF} = p_{s2} - p_{s1}$

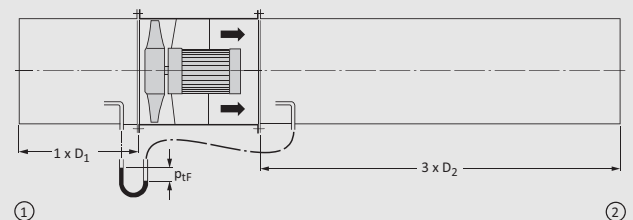

Overall efficiency

The overall efficiency tells how effective the fan arrangement is.

$$\eta_{\text{overall}} = \eta_{\text{fan}} \times \eta_{\text{motor}} \times \eta_{\text{converter}}, \text{ where}$$

η_{overall} : Overall efficiency

η_{fan} : Fan efficiency

η_{motor} : Motor efficiency

$\eta_{\text{converter}}$: Frequency converter

The EU directive 2009/125/EU describes how to calculate overall efficiency with regard to Eco-design requirements. Values for the overall efficiency, measurement category, efficiency category and more are calculated by AirBox and included on the report. The information is also written on the fan nameplates.

Built into duct

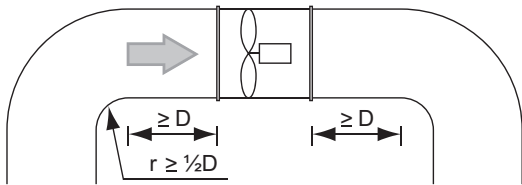

Free inlet

D = Fan diameter

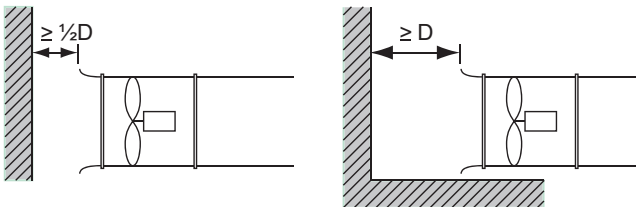

Reduced conditions

Hub diameters	Fan sizes, ØD [mm]	RPM	
		Optimal	Reduced
Ø160	250	4919	—
	280	4747	—
	315	4570	—
	355	4408	—
	400	4269	—
	450	4145	—
	500	4086	—
Ø350	500	3660	3483
	560	3460	3286
	630	3238	3059
	710	3000	2804
	800	2751	2523
	900	2498	2217
	1000	2270	1918
	1120	1900	1568
Ø560	1250	1500	1201
	1000	2034	1904
	1120	1893	1727
	1250	1751	1552
	1400	1599	1371
	1600	1419	1166
	1800	1262	1002
	2000	1130	878

Max. allowable speeds at 20 °C ^{1 2 3}

1. Fan speeds depend on the installation conditions.
2. Fans with Ø160 hubs can run at maximum RPMs at the reduced installation conditions. See table on page 6.
3. All fans are subject to run with reduced RPMs when installed for operation at temperatures outside the interval -20 to 50 °C. Refer to AirBox for specific RPMs.

Installation considerations

Whether ZerAx fans are built into ducts or installed as part of other installations, minimum distances to nearby objects in the airflow path must be observed.

The space at the inlet side must be optimal to ensure a smooth and undisturbed airflow. At less than optimal conditions, the fan speed must be reduced.

Free inlet requires an inlet cone to get optimal performance with regard to efficiency and sound.

Pressure loss example

The air pressure builds up across the fan whereafter it decreases. In this example an acoustic diffuser controls the profile of the airflow and most importantly recovers a large part of the pressure loss. AirBox calculates the desired total pressure available at the system outlet. Here this is the diffuser outlet.

The example here was calculated with AirBox for the following fan and conditions.

- Fan type : AZN
- Airflow : 3 m³/s
- Total pressure, p_{tF} : 369 Pa
- Fan diameter, D_F : Ø500 mm
- Hub size : Ø350 mm
- Blade angle : 60°
- Efficiency : 87%

Built into duct

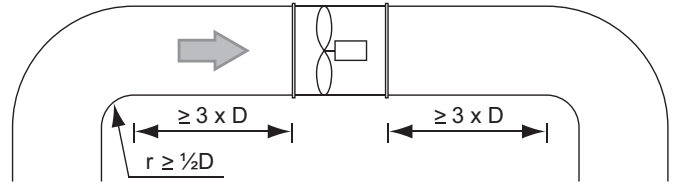

Free inlet

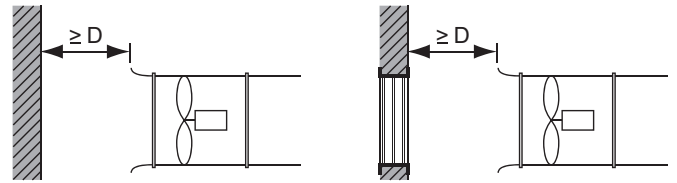

Optimal conditions

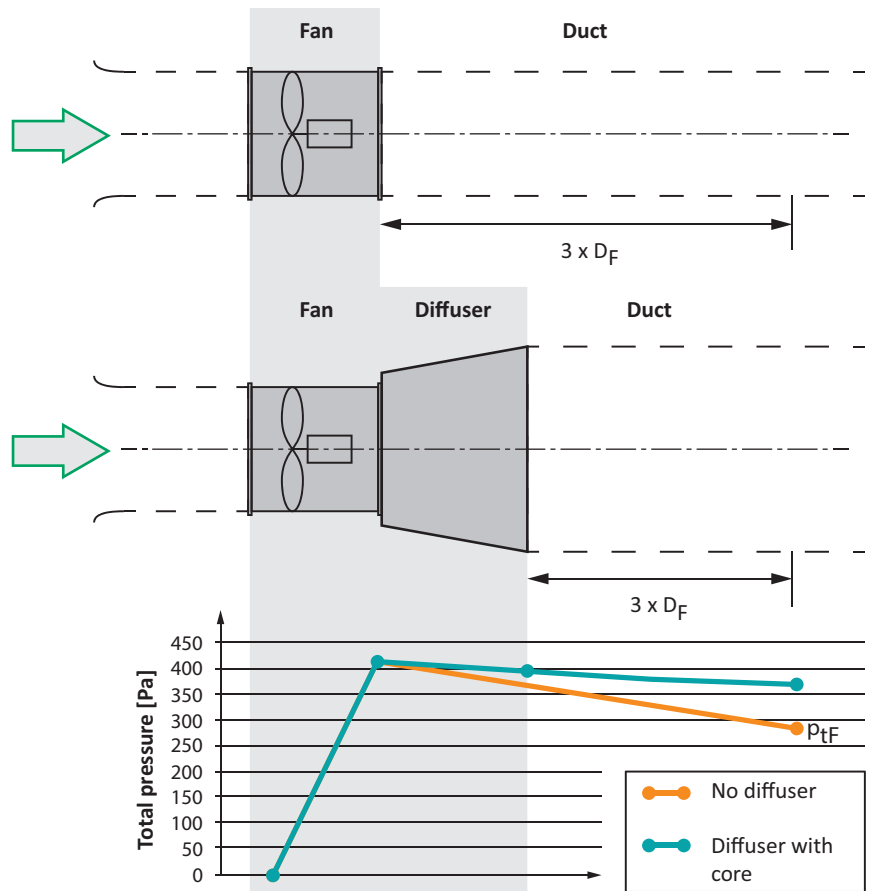

Pressure loss example

Quality and service



Rest assured

The ZerAx axial flow fans are produced in accordance with Novenco's well-known quality standards.

Novenco Building & Industry A/S is ISO certified and all fans are inspected and tested.

The fans are offered with options for technical guidance on installation, test of function and training of personnel.

Important

This document is provided 'as is'. Novenco Building & Industry A/S reserves the right to changes without further notice due to continuous product development.

Pictures in the catalogue may show products with accessories fitted.

The fans are designed for continuous operation. The following kinds of operation may cause fatigue break in the impellers and endanger people.

- Operation in stall area, i.e. with counter pressure that pulsates – called pump mode
- Operation with exceedingly starts and stops
- Uneven flow velocity through fan

If in doubt, Novenco should be contacted to assess the suitability of the fans.

Copyright © 2009 - 2025,
Novenco Building & Industry A/S,
all rights are reserved.

Patents and trademarks

Novenco®, 诺文科, 诺万科 and 诺克 are registered trademarks of Novenco Marine & Offshore A/S. ZerAx® is a registered trademark of Novenco Building & Industry A/S. AirBox™, NoVa™ and NovAx™ are trademarks of Novenco Building & Industry A/S. Other trademarks appearing in this document are the property of their respective owners.

The Novenco ZerAx processes of manufacture, technologies and designs are patented by Novenco A/S or Novenco Building & Industry A/S.

Pending patents include PCT no. EP2012/064908 and EP2012/064928.

Granted patents include Brazil no. BR-11-2012-008543-3; BR-11-2012-008545-0; BR-11-2012-008607-3; BR-11-2014-002282-8 and BR-11-2014-002426-0; Canada

Warranty

Novenco provides according to law a standard 12 months warranty from the product is sent from the factory. The warranty covers materials and manufacturing defects. Wear parts are not covered. Extended warranty can be agreed upon.

no. 2.777.140, 2.777.141, 2.777.144, 2.832.131 and 2.843.132; China no. ZL2010800458842, ZL2010800460965, ZL2010800464275 and ZL2012800387210; EU no. 2488759, 2488760, 2488761, 2739860 and 2739861; India no. 312464, 360298, 367515, 400863 and 403692; South Korea no. 10-1907239, 10-1933724, 10-1980600, 10-2011515 and 10-2127529; US no. 8.967.983, 9.200.641, 9.273.696 B2, 9.683.577 and 9.926.943 B2.

Granted designs include Brazil no. BR-30-2012-003932-0; Canada no. 146333; China no. 1514732, 1517779, 1515003, 1555664 and 2312963; EU no. 001622945-0001 to 001622945-0009 and 001985391-0001; India no. 246293; South Korea no. 30-0735804; UK no. 001622945-0001 to 001622945-0009 and 001985391-0001; US no. D665895S, D683840S, D692119S, D704323S, D712023S, D743018S, D755363S, D756500S, D821560S and D823452S.

Quality and environment

Novenco Building & Industry A/S is certified in accordance with ISO 9001 and 14001.



All Novenco Building & Industry's products are designed, developed and manufactured in Denmark.





info@novenco-building.com

+45 70 77 88 99

novenco-building.com