

Installation Instructions

GLOBAL RX/PX/PX LP

Follow the various changes to this manual on our website:
www.swegon.com

Swegon 

GLOBAL RX/PX/PX LP

Table of Contents

1.0 Installation instructions applicable for the following units	4
2.0 Symbols and abbreviations	6
3.0 Product Overview	7
4.0 Unloading and transport	13
5.0 Installation	14
6.0 QR codes	33

1.0 Installation instructions

Applicable for the following units

EXCHANGER	SIZES	INTEGRATED PRE-HEATING	INTEGRATED POST-HEATING	HANDING
GLOBAL PX Counterflow	04/05/08/12/ 13/16/18/20/24/26	Yes, electrical	Yes, electrical or water	Left/Right
GLOBAL PX Top Counterflow	05/08/10/12/14/18	Yes, electrical	Yes, electrical or water	Left/Right
GLOBAL RX Rotary	08/13/16/18/20/26	No	Yes, electrical or water	Left/Right
GLOBAL RX Top Rotary	05/08/13/16	No	Yes, electrical or water	Left/Right
GLOBAL PX LP Counterflow	02/04/06/08 10/12/13/14/16/18	Yes, electrical	Yes, electrical or water	Left/Right

Disclaimer

Danger/Warning/Caution

- All relevant staff must acquaint themselves with these instructions before beginning any work on the unit. Any damage to the unit or its components caused by improper handling or misuse by the purchaser or the installer are not covered by the guarantee if these instructions have not been followed correctly.
- Make sure that the mains supply to the unit is disconnected before performing any maintenance or electrical work!
- All electrical connections must be made by a qualified electrician and in accordance with local rules and regulations.
- There is still risk of injury due to rotating parts that have not come to a complete standstill even though the mains supply to the unit has been disconnected.
- Beware of sharp edges during assembly and maintenance. Make sure that a proper lifting device is used. Wear protective clothing.
- The unit may only be operated with the doors and panels closed.
- If the unit is installed in a cold location make sure that all joints are covered with insulation and are well taped.
- Duct connections/duct ends should be covered during storage and installation, in order to avoid condensation inside of the unit.
- Check that there are no foreign objects in unit, ducting system or functional sections.
- The unit is packed to prevent damage of the external and internal parts of the unit, dust and moisture penetration. If the unit is not to be installed immediately, it should be stored in a clean, dry area. If stored externally, it should be adequately protected from the weather influences.
- If the filter or any other spare parts are not replaced as the original model, Swegon cannot be responsible for any damages that might occur on the unit or on all the installation.

RANGE OF APPLICATION

The GLOBAL units are designed for use in comfort ventilation applications.

Depending on the variant selected, GLOBAL units can be utilised in buildings such as office buildings, schools, day nurseries, public buildings, shops, residential buildings, etc.





















GLOBAL units equipped with plate heat exchangers (PX) can also be used for the ventilation of moderately humid buildings; however not where the humidity is continuously high, such as in indoor swimming baths, saunas, spas or wellness centres.

Please do contact us if you have a need for a unit that is suited for such an application

HOW TO READ THIS DOCUMENT

Please make sure that you have read and understood the safety precautions below. For new users, please read the chapter where the Symbols and Abbreviations used for GLOBAL are listed.

2.0 Symbols and abbreviations

	BW	BACKWARD CURVED FAN			
	BF	BAG FILTER		PF	PLEATED FILTER
	RX	ROTARY HEAT EXCHANGER		PX	PLATE HEAT EXCHANGER
	WARNING			<p>Electronic boards contains ESD sensitive components. Wear antistatic wrist strap connected to protective earth before to manipulate them. In alternative, discharge by touching the unit, handle boards at corners only and use antistatic gloves.</p>	
	<p>Must be connected by a qualified Electrician. Warning! Hazardous voltage.</p>				
	OUTDOOR AIR		Air from outdoor to the AHU (OA)		
	SUPPLY AIR		Air from the AHU to the building (SA)		
	EXTRACT AIR		Air from the building to the AHU (ETA)		
	EXHAUST AIR		Air from the AHU to outdoor (EHA)		
	COOLING COIL	BA-		NV/KW	HEATING COIL (WATER/ELECTRICAL)
	SILENCER	GD		CTm	MOTORISED DAMPER
	PRESSURE SENSOR	P		Tx	TEMPERATURE SENSOR No = x (1,2,3...)
	SLIP CLAMP Sliding bar and screws are not included	SC		MS	FLEXIBLE CONNECTION
CIRCULAR DUCT CONNECTION		ER	For inlet	SR	For outlet

3.0 Product Overview

3.1 GENERAL OVERVIEW

RIGHT HAND UNIT (SUPPLY AIR TO THE RIGHT)

LEFT HAND UNIT (SUPPLY AIR TO THE LEFT)

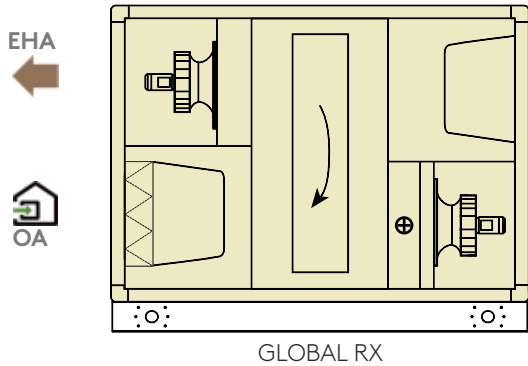

GLOBAL RX

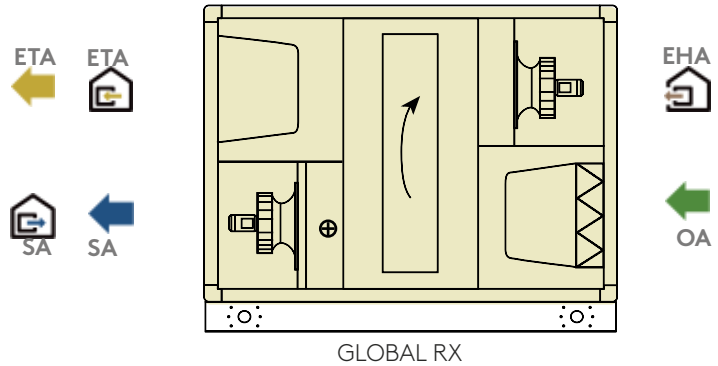

GLOBAL RX

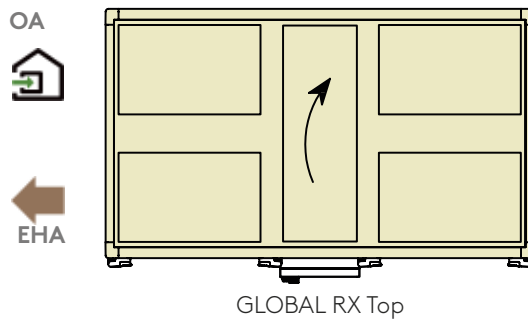

GLOBAL RX Top

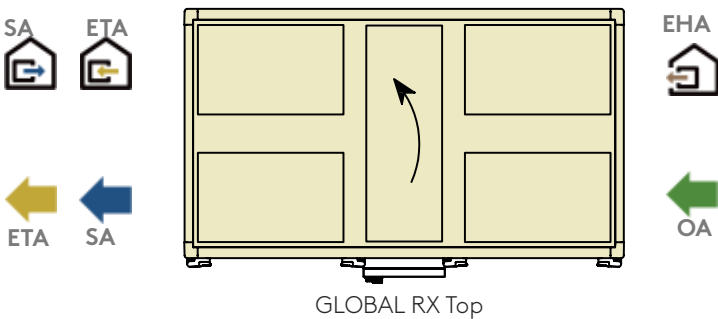

GLOBAL RX Top

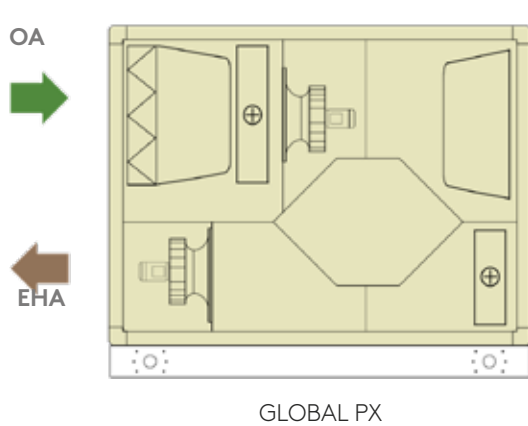

GLOBAL PX

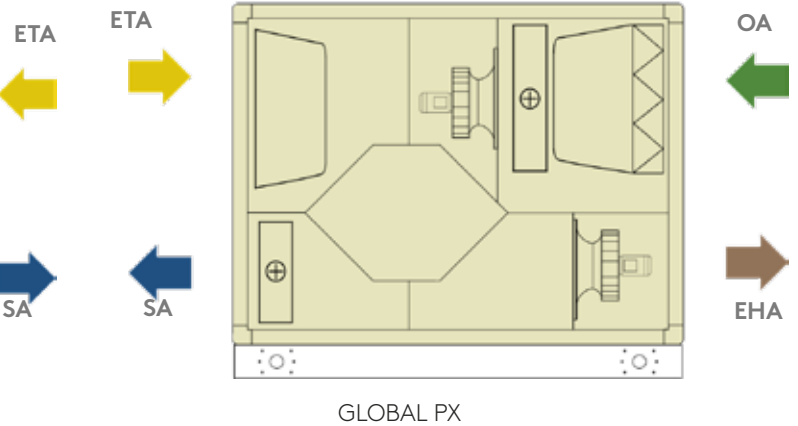

GLOBAL PX

RIGHT HAND UNIT (SUPPLY AIR TO THE RIGHT)

LEFT HAND UNIT (SUPPLY AIR TO THE LEFT)

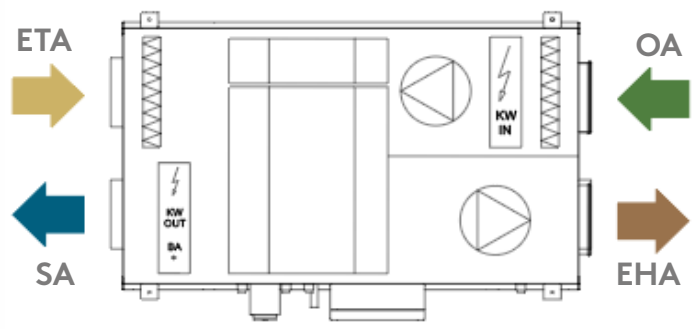
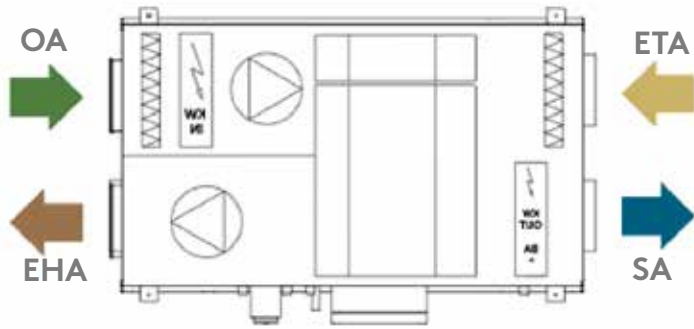

GLOBAL PX LP 02-04-06-08-10-14-18
(top view)

GLOBAL PX LP
(top view)

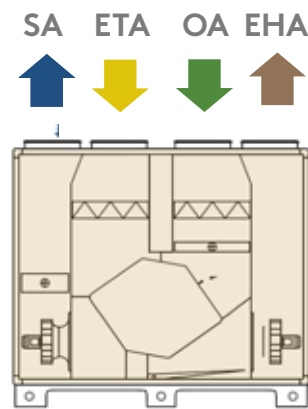
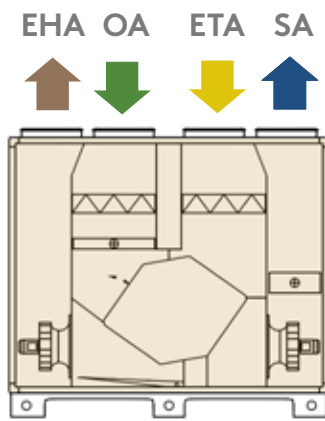

GLOBAL PX Top 05 - 10

GLOBAL PX Top 05 - 10

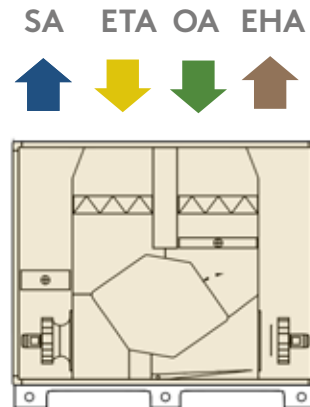
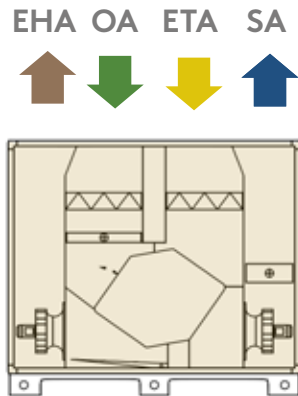

GLOBAL PX Top 12 - 18

GLOBAL PX Top 12 - 18



ATTENTION

Right and left hand units have different article numbers and should be ordered accordingly. Main version described in the manuals is always the hand right version.

The difference between left and right PX LP units is the factory placement of the controls box on opposite sides.



- | | |
|--|--|
| <ul style="list-style-type: none"> 1. Main switch for power supply AHU 2. Main switch for power supply electrical coils (both internal pre-heating and post-heating) 3. Electrical cabinet 4. Supply fan 5. Extract fan 6. Kit CA -airflow measurement (option) 7. Outdoor air filter (bag or pleated) 8. Extract air filter (bag or pleated) 9. Heat exchanger (Plate or Rotary) 10. Modulating 100% bypass (PX only) 11. Drain pan and drain pipe (PX only) | <ul style="list-style-type: none"> 12. Preheating coil (PX only) 13. Internal post-heating water or electrical coil (option) 14. Motorised damper (accessory) 15. Motorised damper (accessory) 16. Access panel 17. Flexible sleeve (accessory) 18. Slip clamp (accessory) 19. Water connection for post-heating (accessory) 20. Box I/O (inlet/outlet) 21. Additional feet 205 mm (accessory) 22. Protection cover |
|--|--|



1, 2 and 3 must be installed by a qualified electrician

Note: internal electrical coils, motorised dampers, internal fan-pressure sensors, flexible connections and slip-clamps must be ordered and are all pre-installed and factory wired. The internal heating water-coil accessory is pre-installed, but must be connected, hydraulically and electrically, by the installer.

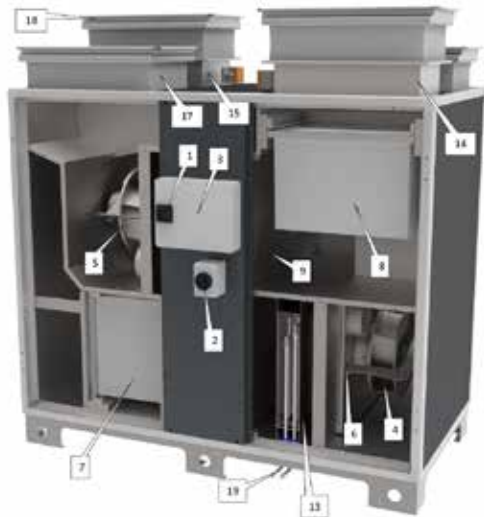

GLOBAL RX TOP

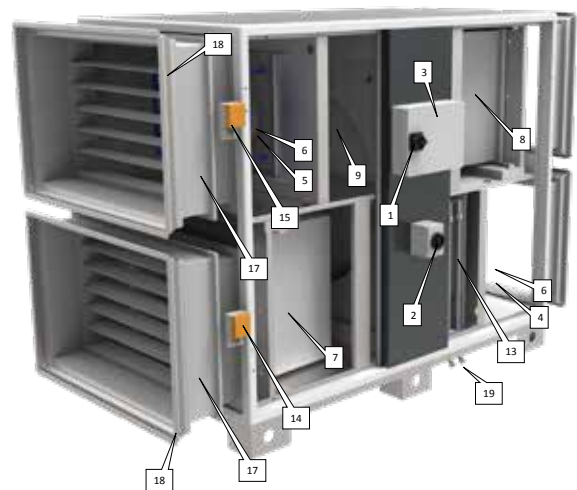

GLOBAL RX

1. Main switch for power supply AHU
2. Main switch for power supply electrical coils (both internal pre-heating and post-heating)
3. Electrical cabinet
4. Supply fan
5. Extract fan
6. Kit CA -airflow measurement (option)
7. Outdoor air filter (bag or pleated)
8. Extract air filter (bag or pleated)
9. Heat exchanger (Plate or Rotary)
10. Modulating 100% bypass (PX only)
11. Drain pan and drain pipe (PX only)
12. Preheating coil (PX only)
13. Internal post-heating water or electrical coil (accessory)
14. Motorised damper (accessory)
15. Motorised damper (accessory)
16. Access panel (PX LP only)
17. Flexible sleeve (accessory)
18. Slip clamp (accessory)
19. Water connection for post-heating (accessory)



1, 2 and 3 must be installed by an accredited electrician

Note: internal electrical coils, motorized dampers, internal fan-pressure sensors, flexible connections and slip-clamps have to be ordered initially and are all pre-mounted and factory wired. Internal heating water-coil accessory is pre-mounted but has to be hydraulically and electrically connected by the installer.

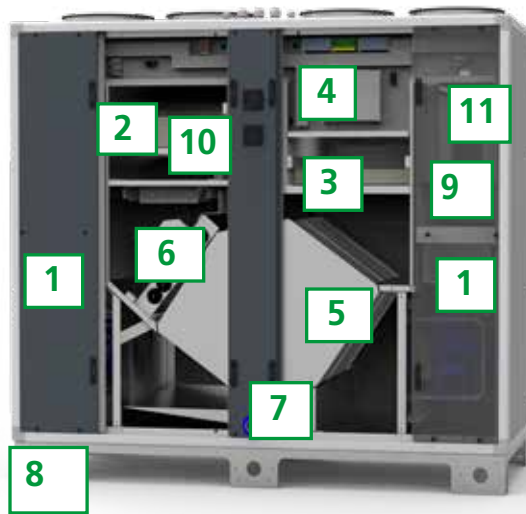

GLOBAL PX TOP

1. EC Plug fan w/composite fan blades (aluminium blades optional)
2. Fresh air filter ePM1≥60% filter class
3. Extract air filter ePM1≥50% filter class
4. Integrated TAC controller
5. High efficiency counterflow plate heat exchanger
6. Modulating 100% BYPASS
7. Stainless steel drain pan
8. Base frame for easy on site transport
9. Integrated post-heating (water/electrical)
10. Integrated pre-heating (electrical)
11. Silencer

3.2 MAINTENANCE AREA



SIZE		WITHOUT COIL [MM]	WITH COIL [MM]	SIZE		WITHOUT COIL [MM]	WITH COIL [MM]
GLOBAL PX	04	500	550	GLOBAL PX Top	05	500	550
	05				550	750	
	06				600	750	750
	08					900	900
	12	900	1100	GLOBAL RX Top	12	600	1100
	13				1300		
	16	600	1550	GLOBAL RX Top	05	650	750
	18	900	1950		08		
	20	600	1550		13	750	900
	24		1950		16	900	1100
GLOBAL RX	13	750	900				
	16	900	1100				
	18	750	1300				
	20						
	26				1550		

There should be 600mm of space on both sides of the device

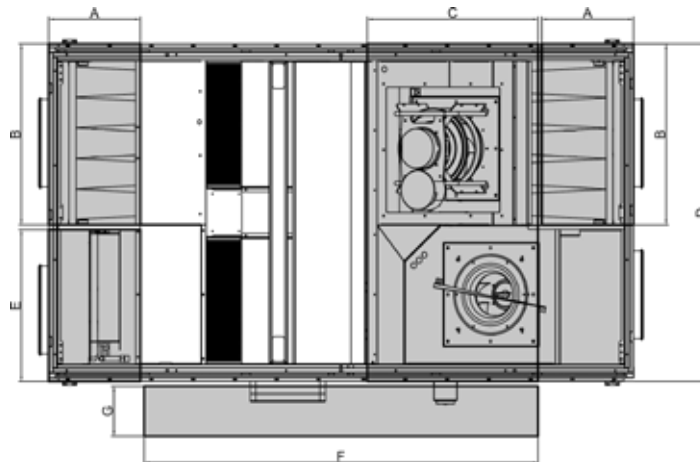

SIZE		A [MM]	B [MM]	C [MM]	D [MM]	E [MM]	F [MM]	G [MM]	SPACE REQUIRED FOR DOORS OPENING [MM]	SPACE REQUIRED FOR COMPONENT HANDLING [MM]
GLOBAL PX LP	02	200	400	300	800	400	900	500	50	300
	04		500		1000	500				
	06	350	500	600	950	500	1400			600
	08		650		1200	550				
	10		950	650	1500	550				
	12				1600	650	1550			
	13	1200	1000	1850	900	1750				
	14	900								
	16									
	18									

4.0 Unloading and transport

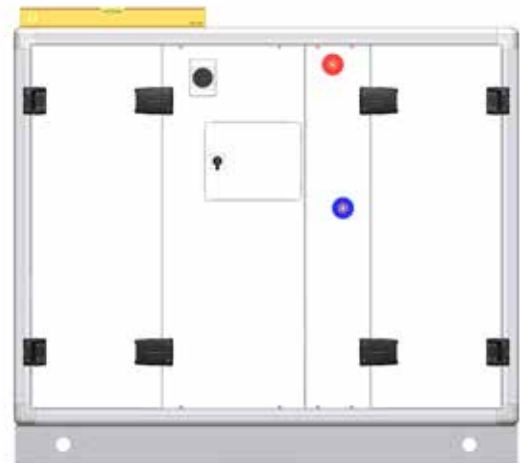

If it is necessary to dismantle and re-assemble the unit due to the delivery through size-limited openings; the unit must be specifically ordered from the factory with the "dismantle option". For information on how to dismantle and re-assemble the unit please download the "Dismantling and Re-Assembly guide" on our website.

5.0 Installation

Since some of the wiring is dependent on the chosen functionality, connection of external controls signals such as 0-10 V signals are described in the "Start-up, Operation and Maintenance Manual" downloadable on our website.

5.1 MECHANICAL INSTALLATION

Note: Some accessories are shipped inside of the unit.

SLIP CLAMPS (SC)

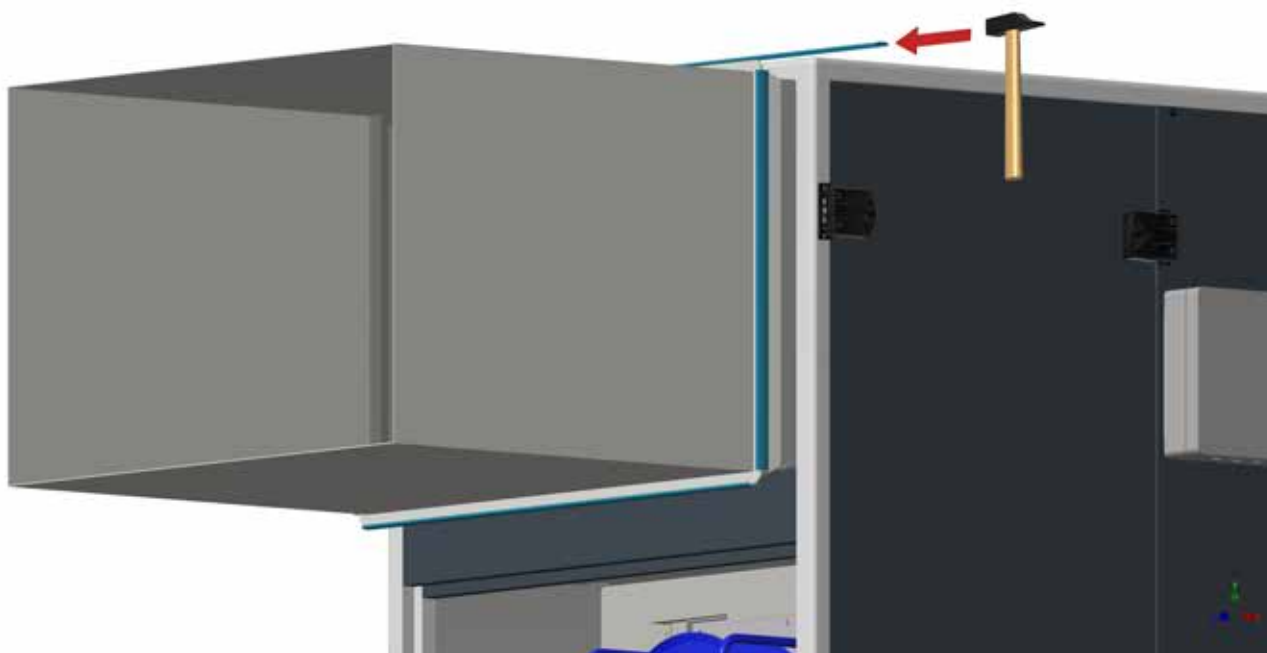

Sliding bar and screws are not included

EXTERNAL INSULATED CASING (ECA)

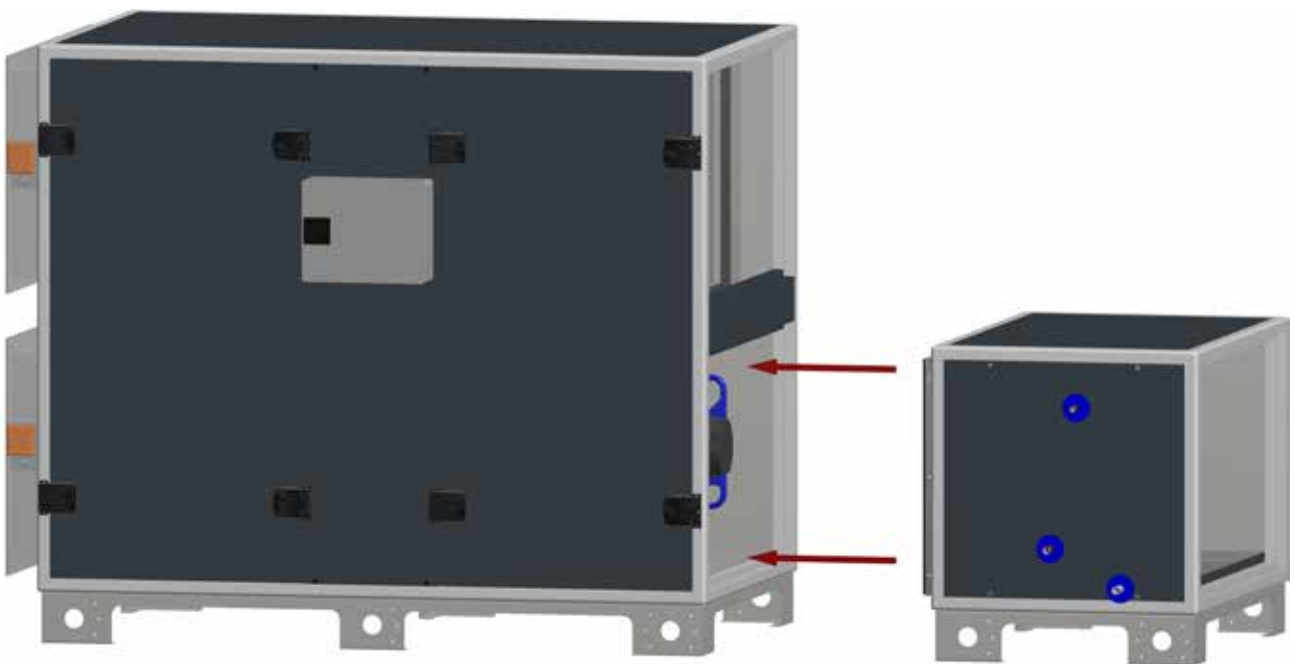
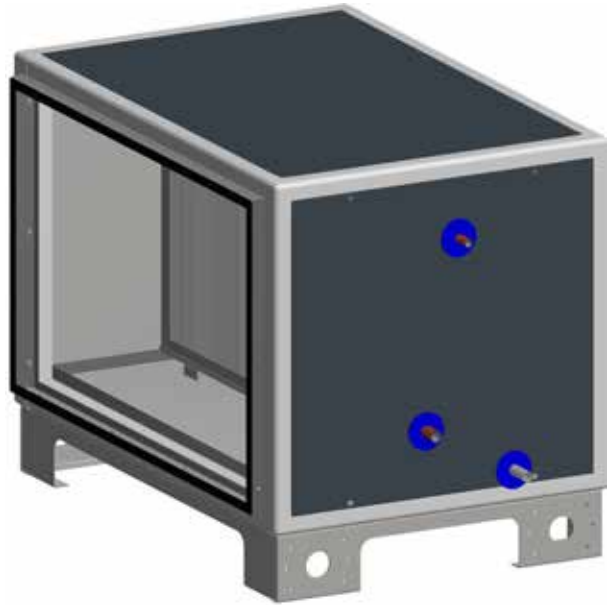

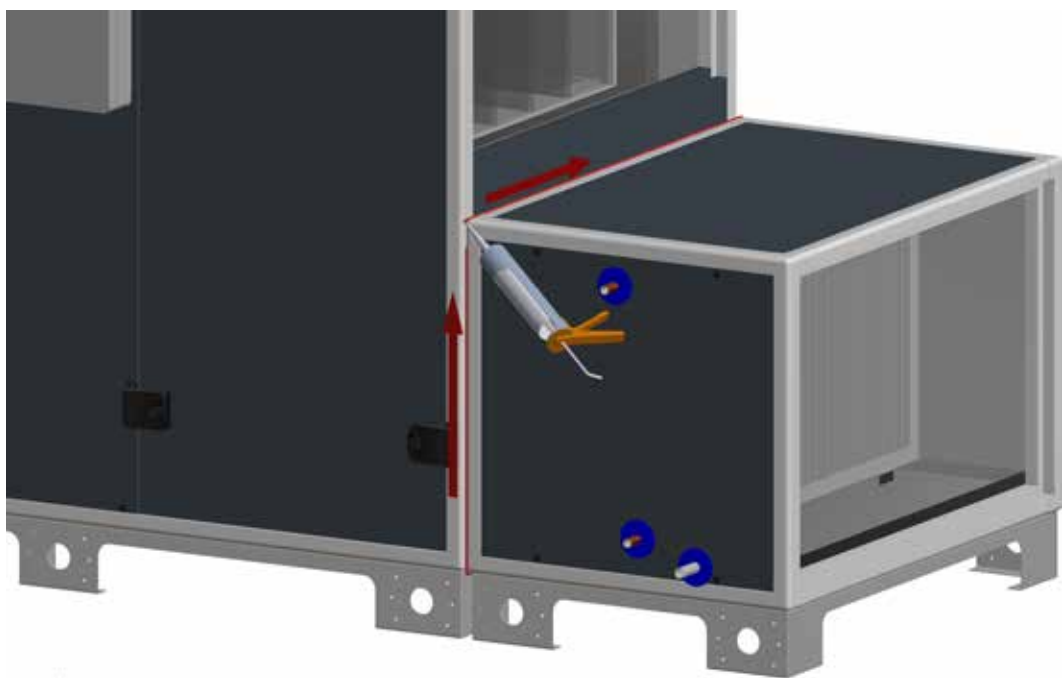
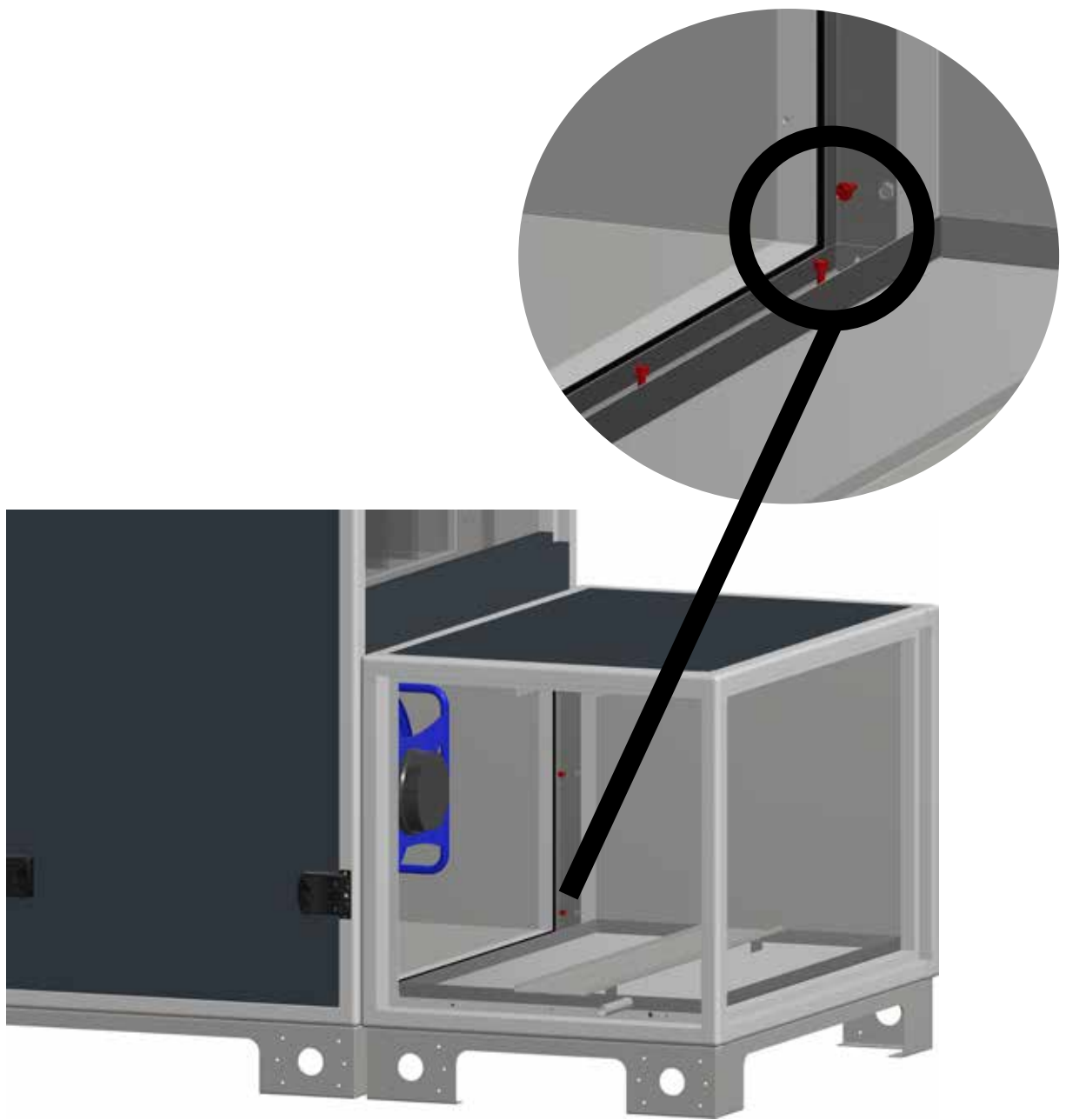

FLEXIBLE CONNECTIONS (MS)

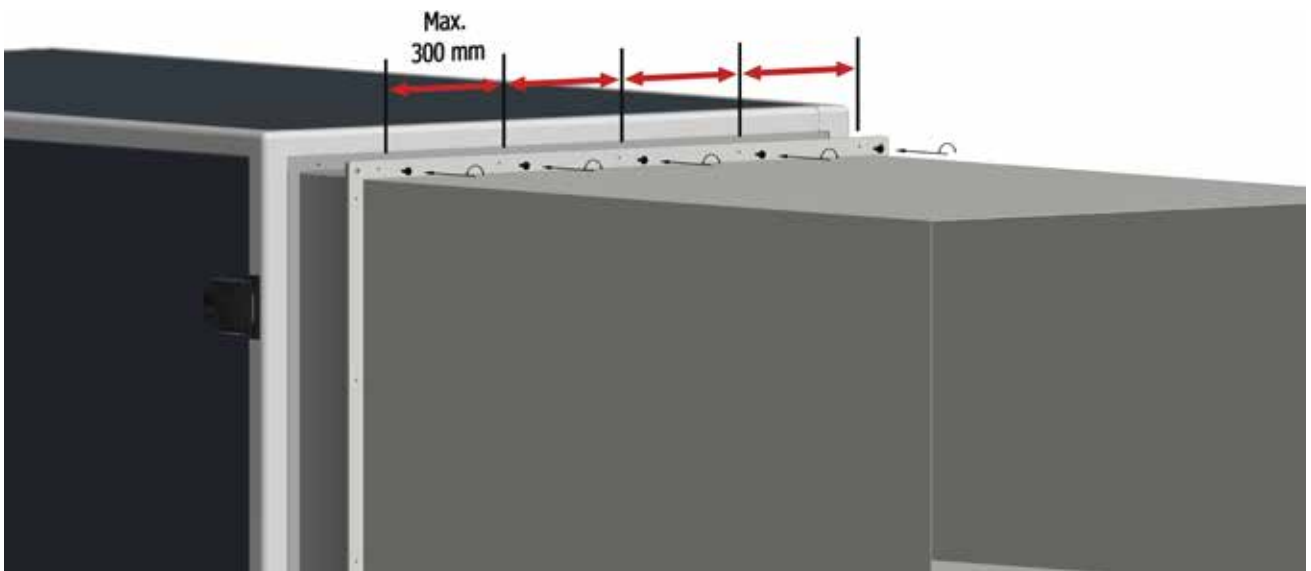
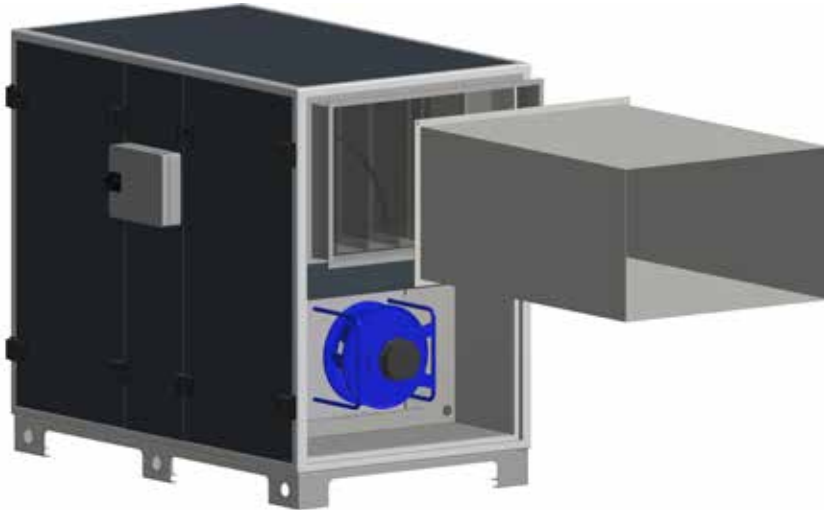

CIRCULAR CONNECTIONS

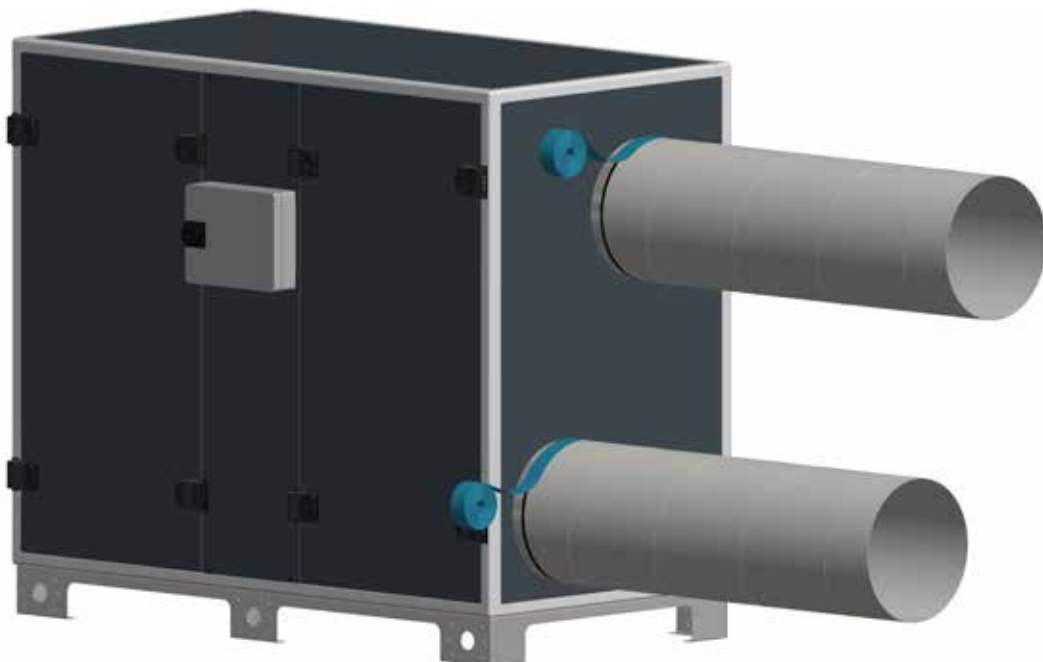

INSTALLATION OF ROOF FOR MOUNTING OUTDOORS (OUT)

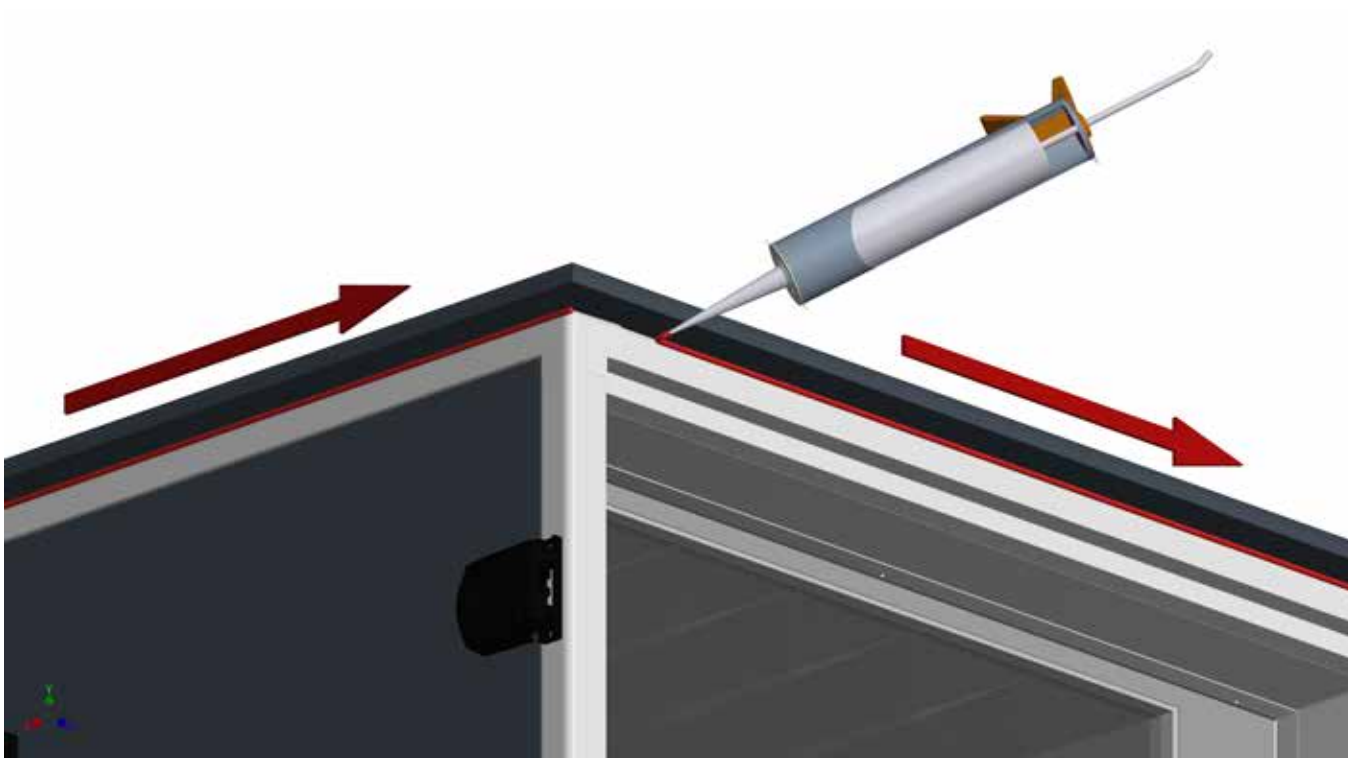
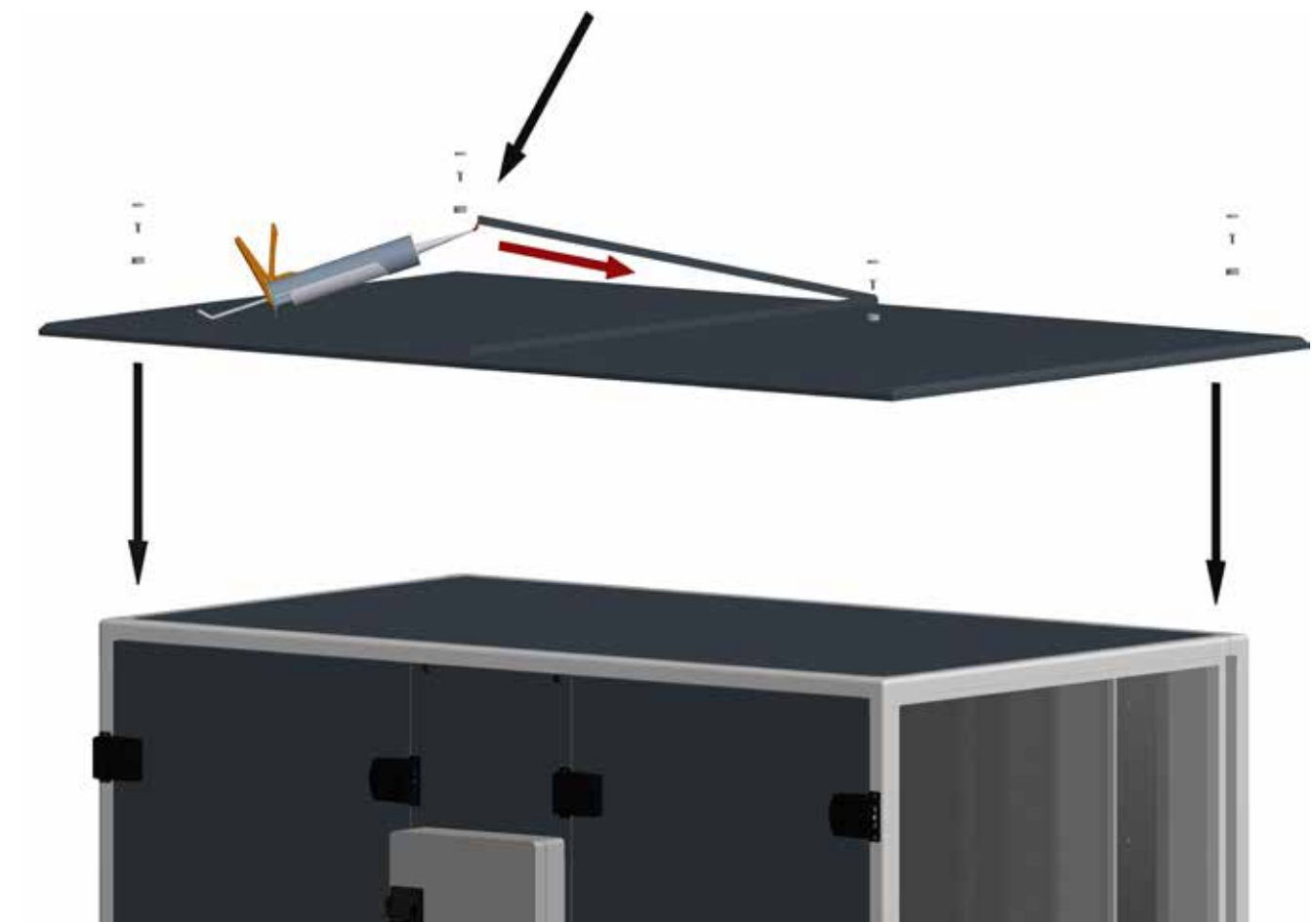

MECHANICAL INSTALLATION FOR GLOBAL PX LP 16/18

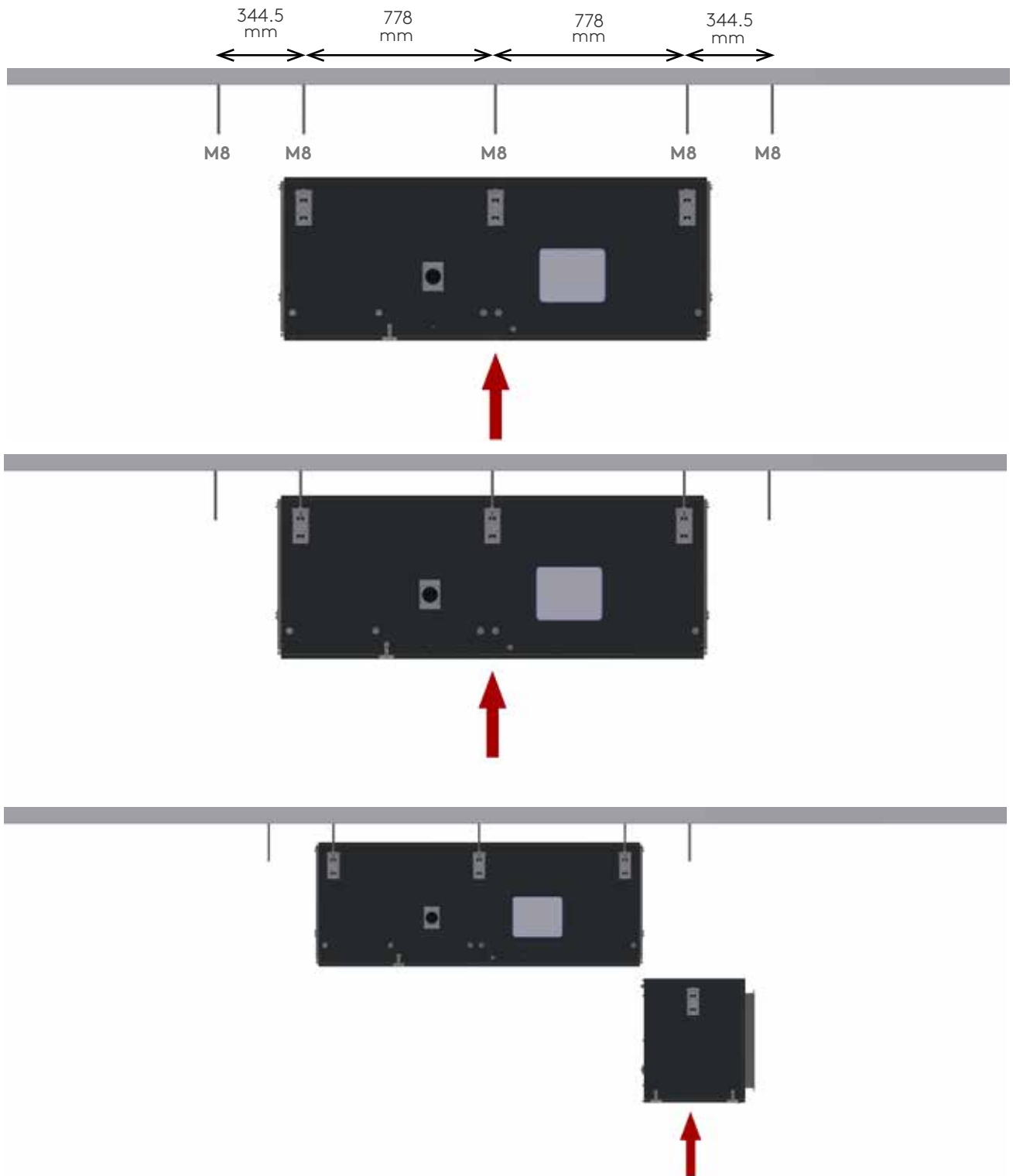

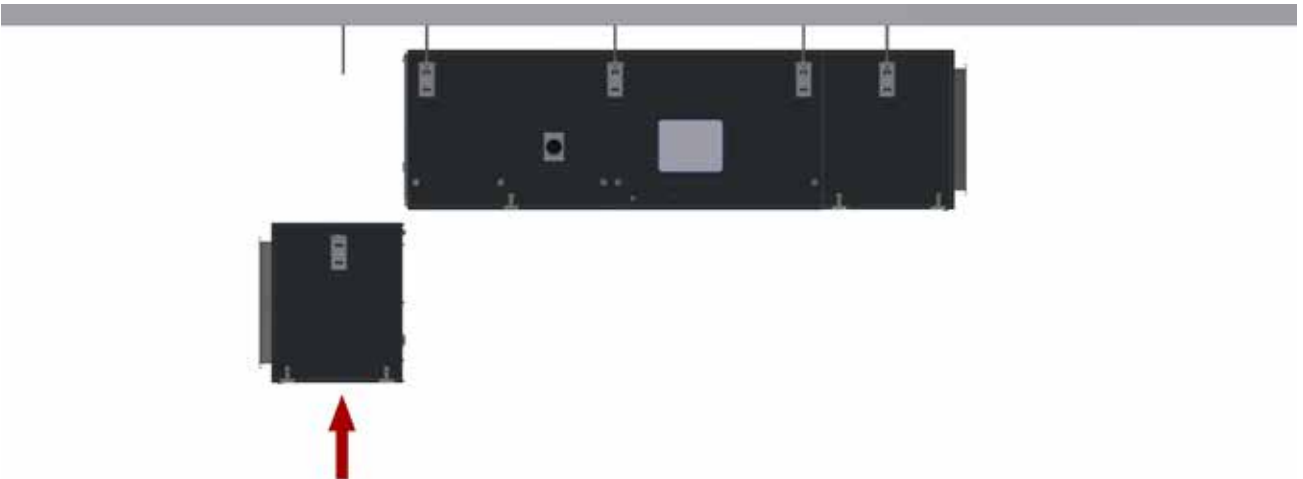
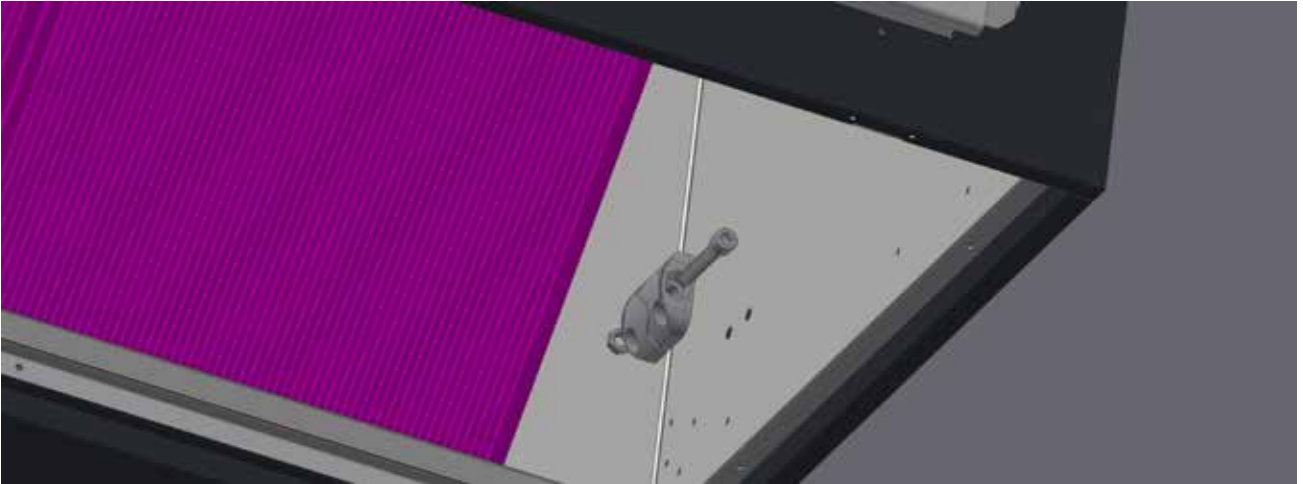

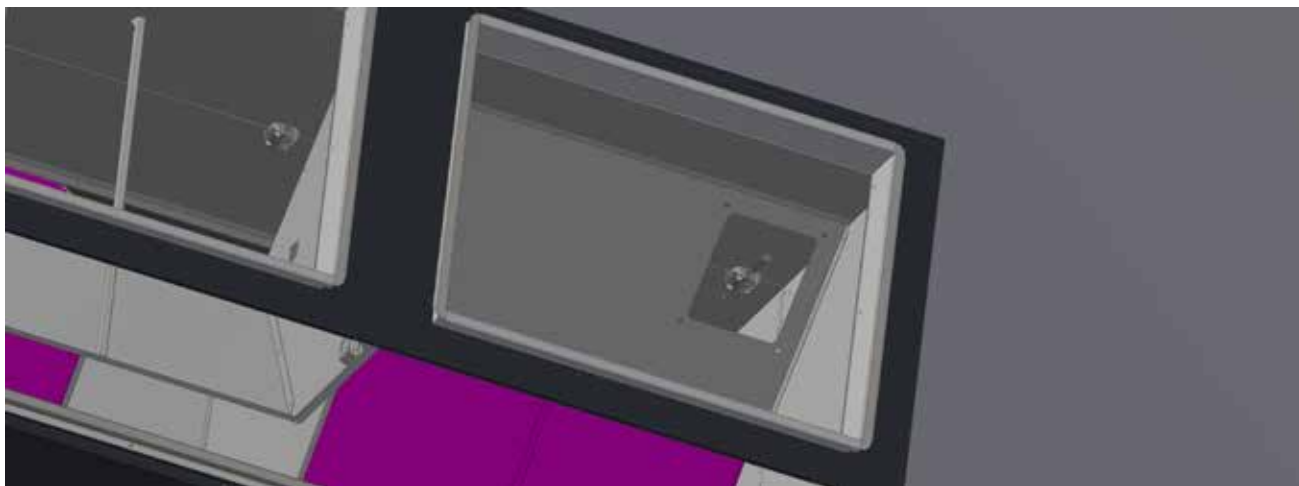
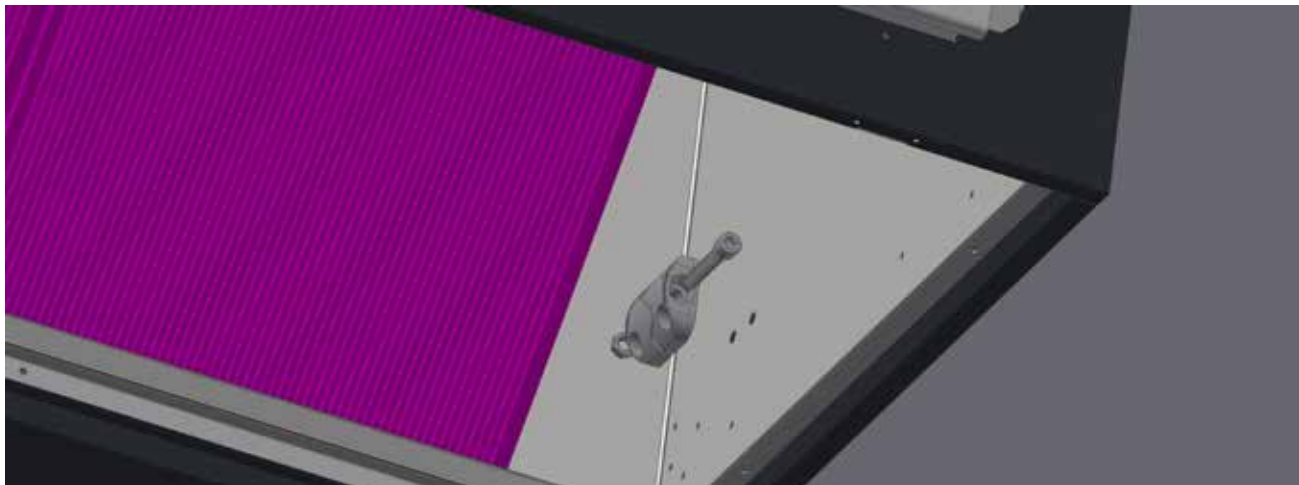

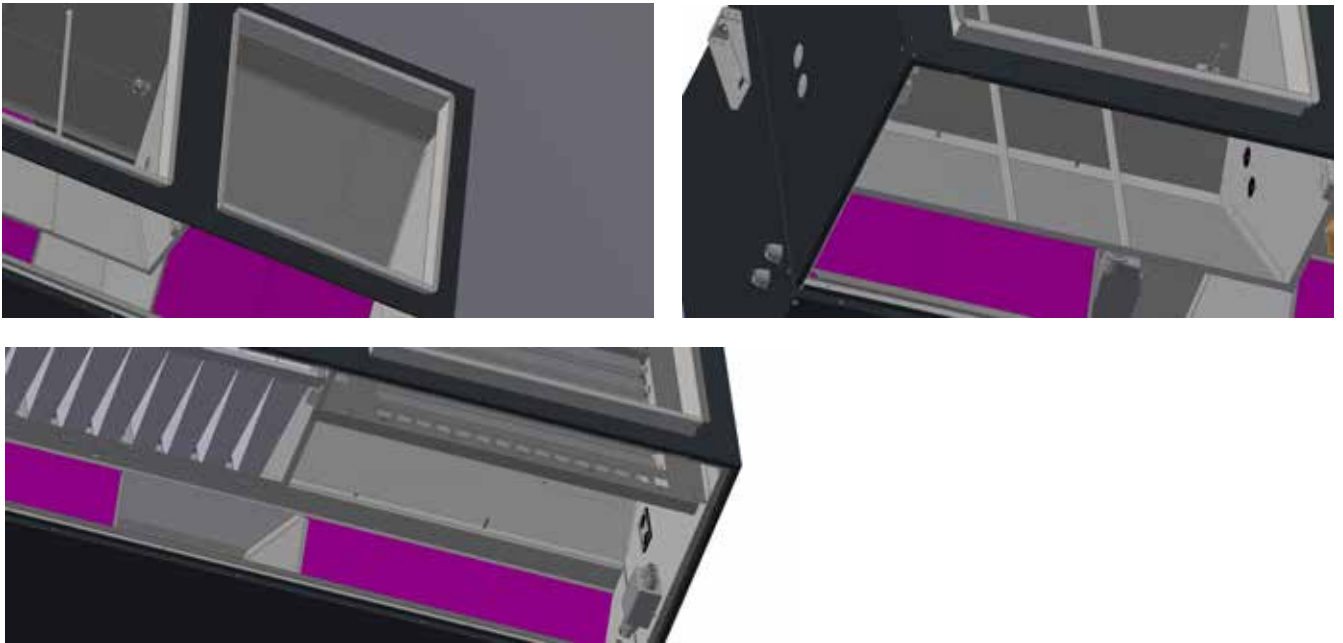

IMPORTANT: for the GLOBAL PX LP unit:

- The two central panels must remain free of access to allow removal of the panels giving access to the fans and condensate tray,
- The side doors must remain freely accessible for maintenance,
- There must be a minimum clearance of 5 cm between the doors and the false ceiling.

GLOBAL PX LP 16/18

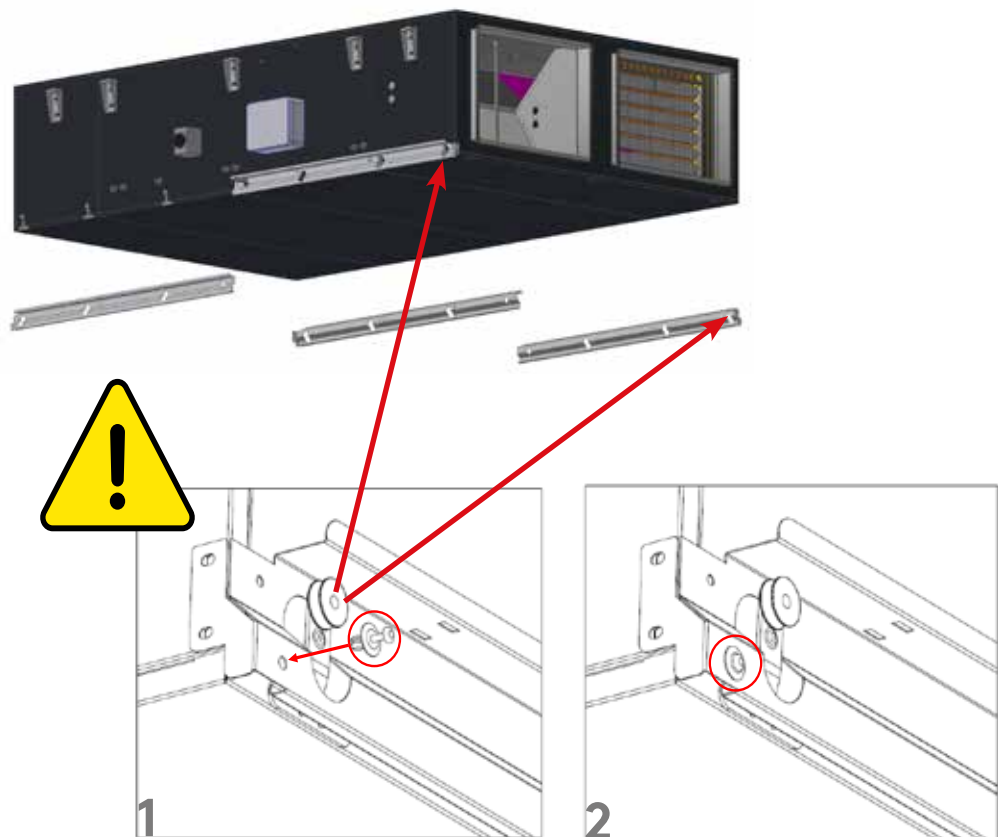

MECHANICAL INSTALLATION FOR GLOBAL PX

Assembly procedure for Global PX 20-24-26 multi-block units



1. Remove the front and rear doors of the secondary block

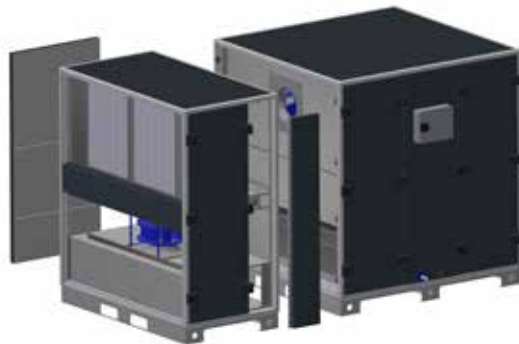

2. Place the 2 blocks side by side.



- Using a hexagonal key, tighten the clams screws (4 at the front and 4 at the back). Insert the tool through the bore hole in the profile.

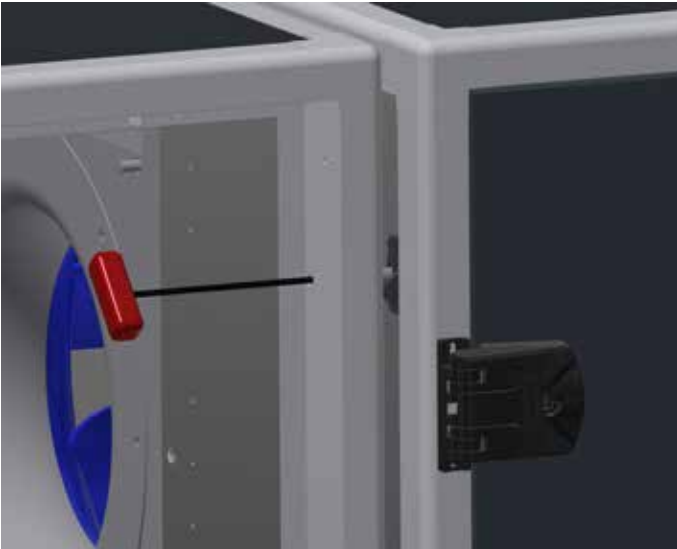

- Blank off the profile holes with the small black plugs to ensure suitable tightness.



- Connect the jumper wires of the main block to the terminal blocks inside a sliding connection box.

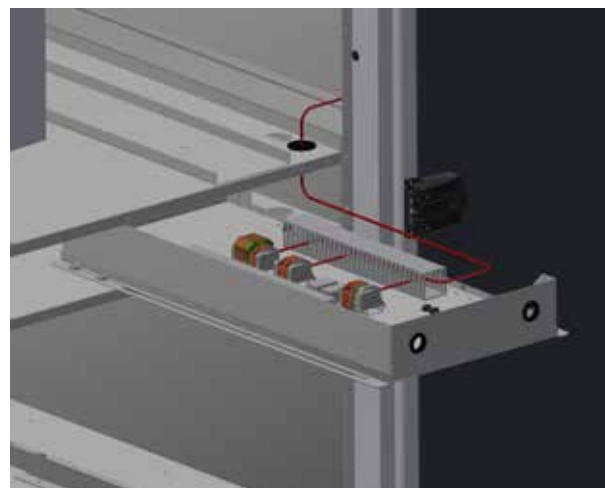

6. The assembly procedure is now complete.



5.2 HYDRAULICAL INSTALLATION

CONDENSATE PUMP FOR GLOBAL PX LP

Specifications	Power supply:	120/240 Vac, 50/60 Hz Auto sensing
	Power consumption:	16 W max., 0.25 W when idle
	Alarm relay:	5A, 30 Vdc, 250 Vac Break on fault
	Capacity:	12 litres/hour max. (3.17 US gal/h)
	Maximum head:	Vertical >20 m (65 ft), Horizontal >100 m (328 ft)
		Suction 1 m max. (3.28 ft)
	Ambient temp:	0 - 40°C
	Water temp:	25°C max.
	Material:	Flame retardant ABS UL94 5VA
	Discharge tube:	6 mm (1/4") ID
	Dimensions:	160 x 43 x 34 mm (6.3" x 1.7" x 1.3")
IP:	68	

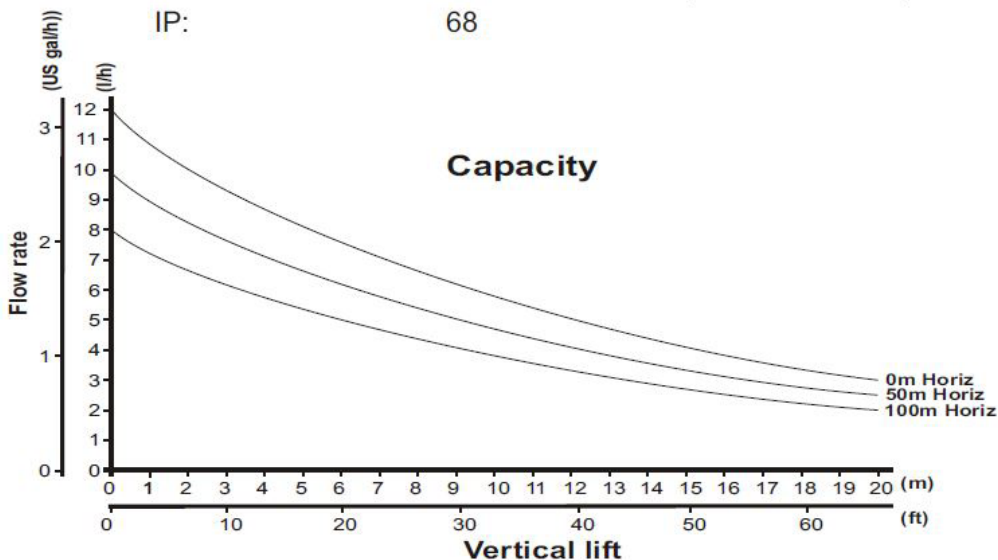

DRAIN-PAN CONNECTION FOR GLOBAL PX

SYPHON FOR INDOOR INSTALLATION

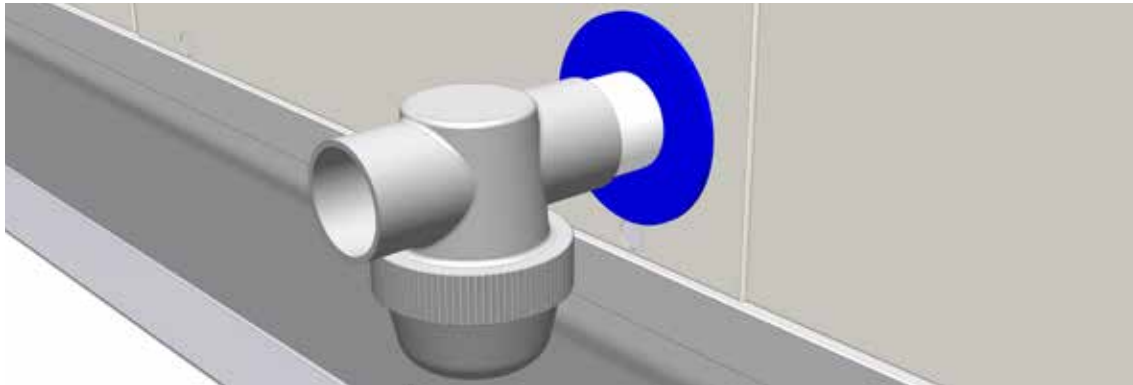

SYPHON FOR OUTDOOR INSTALLATION

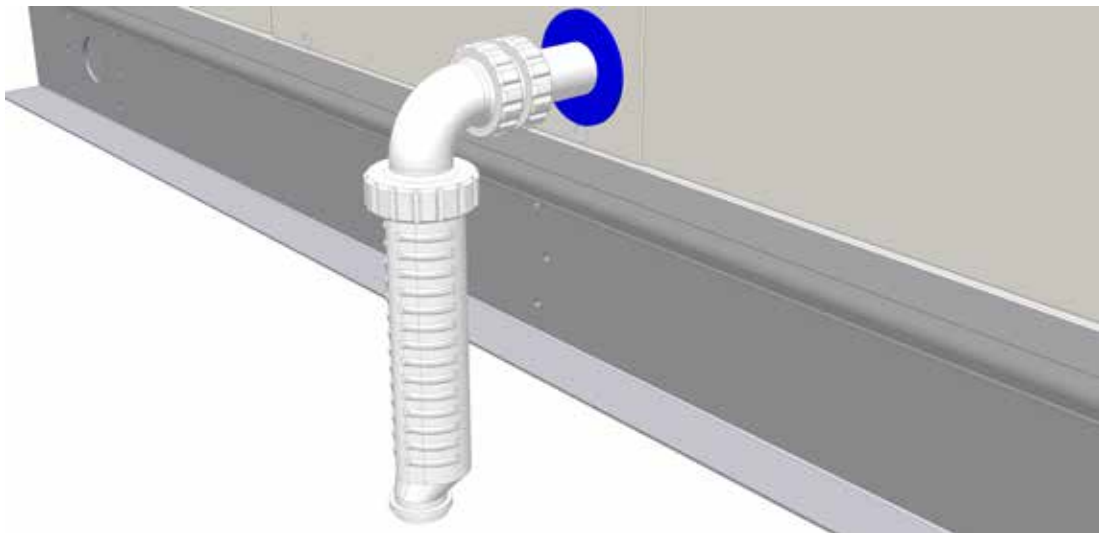

INTERNAL POST-HEATING COIL
GLOBAL RX (Top)

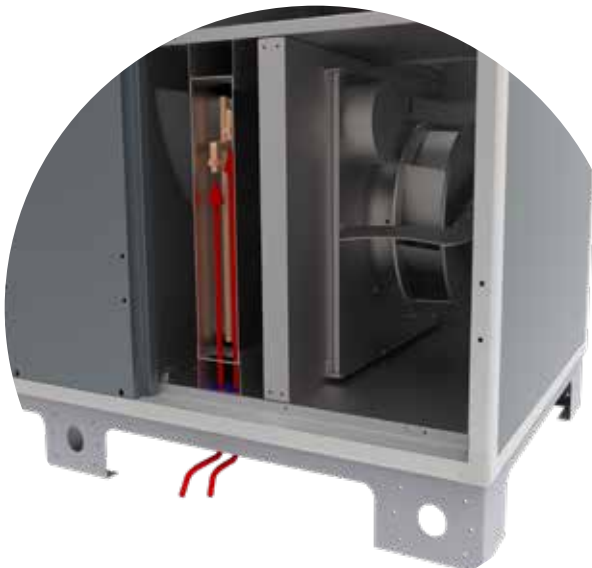

GLOBAL PX

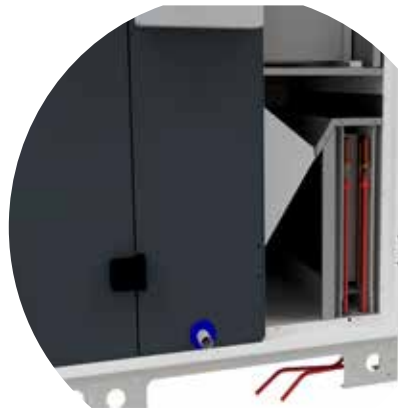

GLOBAL PX Top

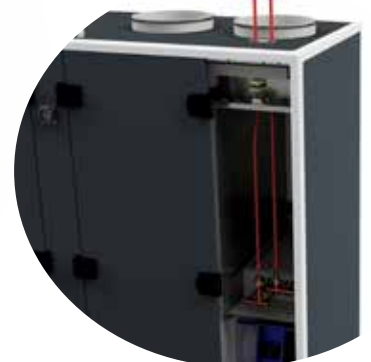

INTERNAL POST-HEATING WATER COIL GLOBAL RX (Top)

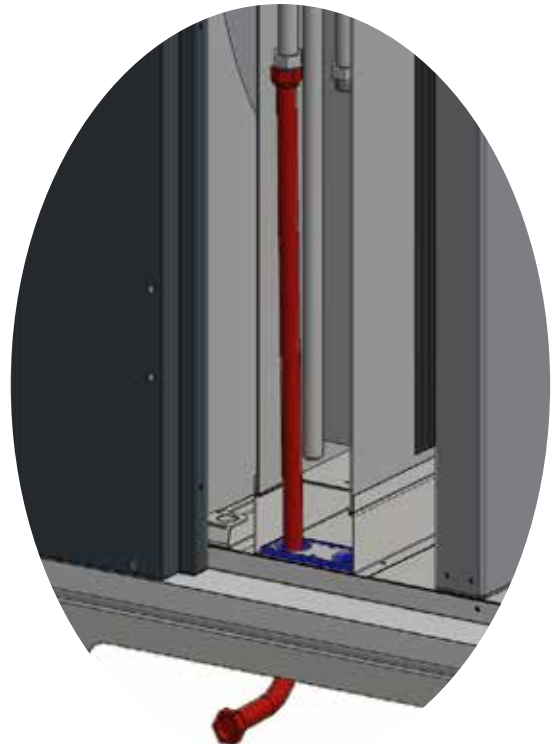
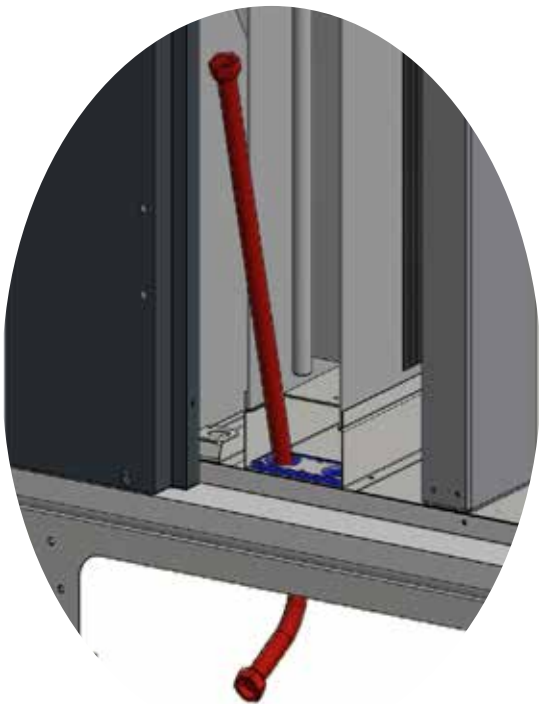
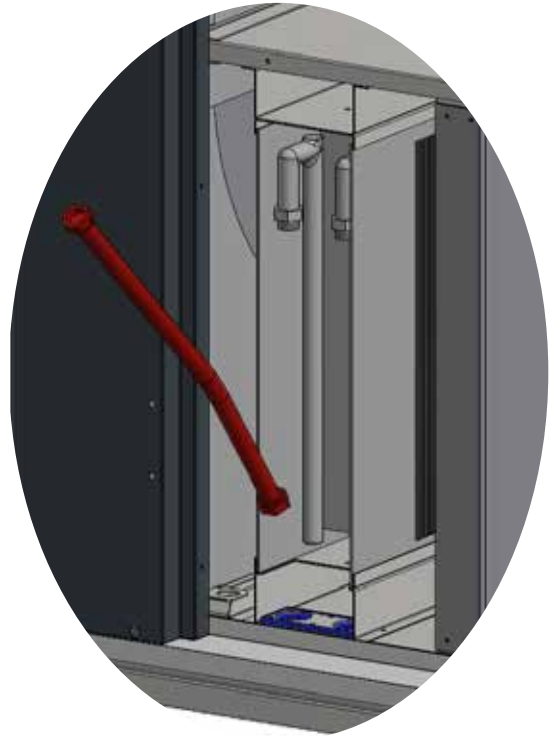
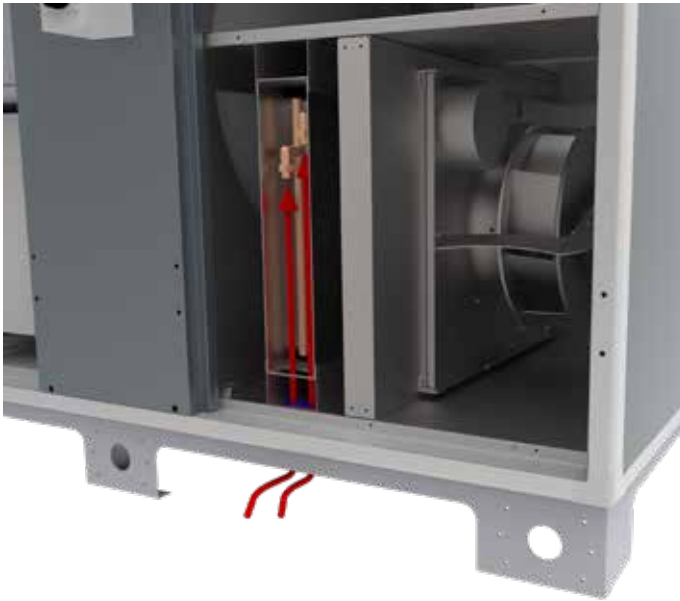

5.3 ELECTRICAL CONNECTIONS

SUPPLY AIR TEMPERATURE SENSOR T5

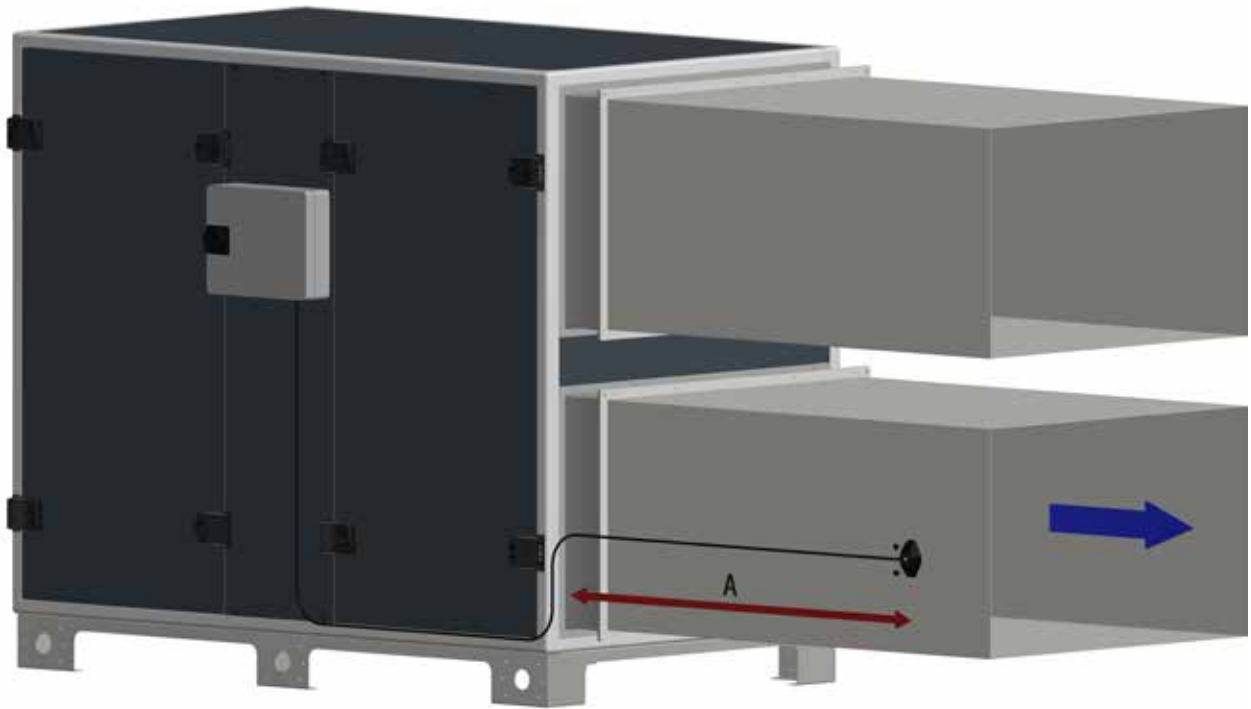

A = minimum 1.5 m

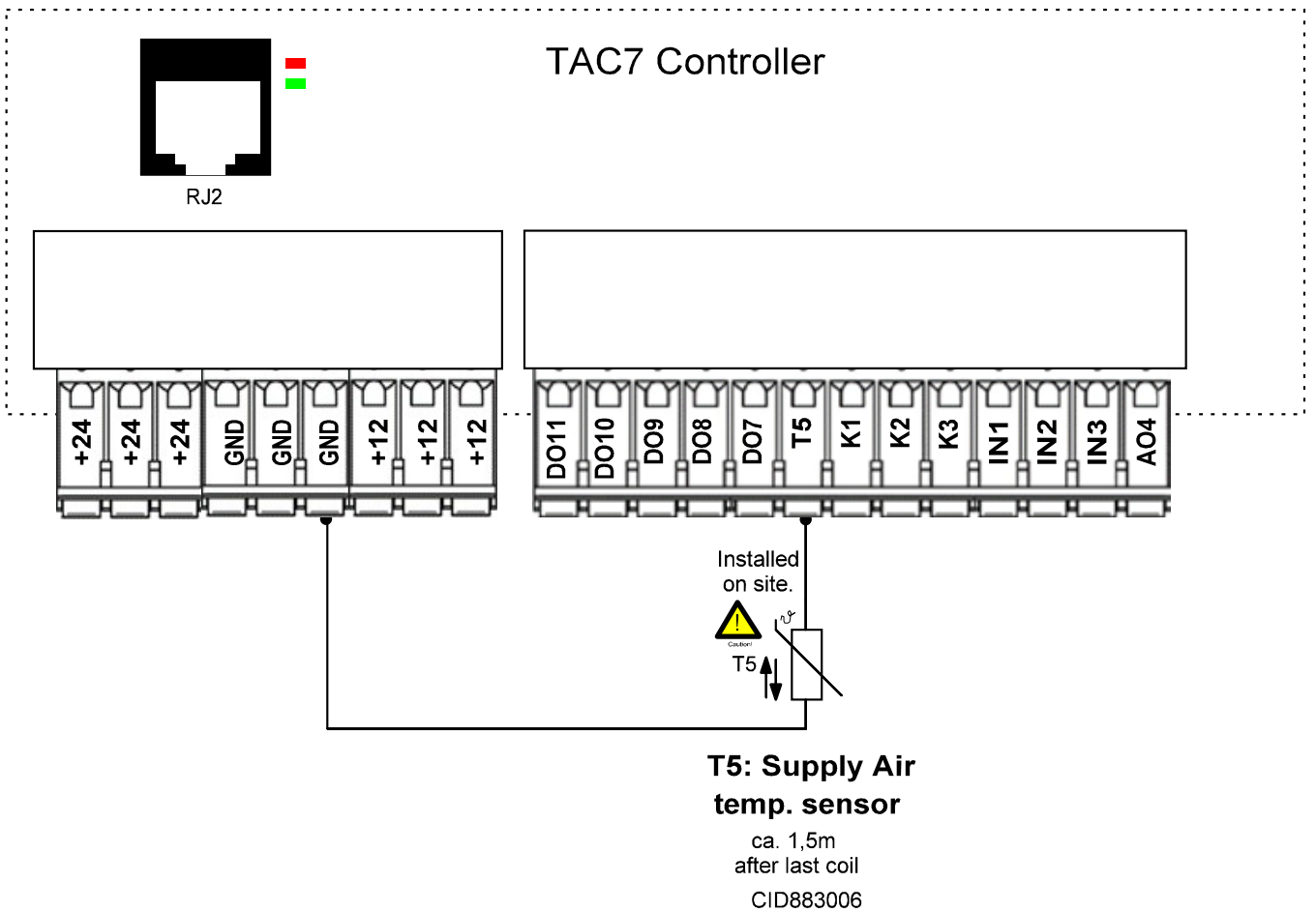

TOUCH SCREEN HMI (TACtouch)

The HMI consists of a 4.3" touch screen with a 1.5m long cable for connection to the AHU control circuit board. If the HMI is not used for 20 min., it switches over to the sleep mode. The touch screen controller can be used outdoors, but it must be kept at a weatherproof place.

Data:
 Operating temperature: 0...+50°C
 Max. length of the cable [m]: ≤ 100
 Protection class: IP20
 Dimensions [mm]: 144x97x20
 Power consumption: 1.8 VA

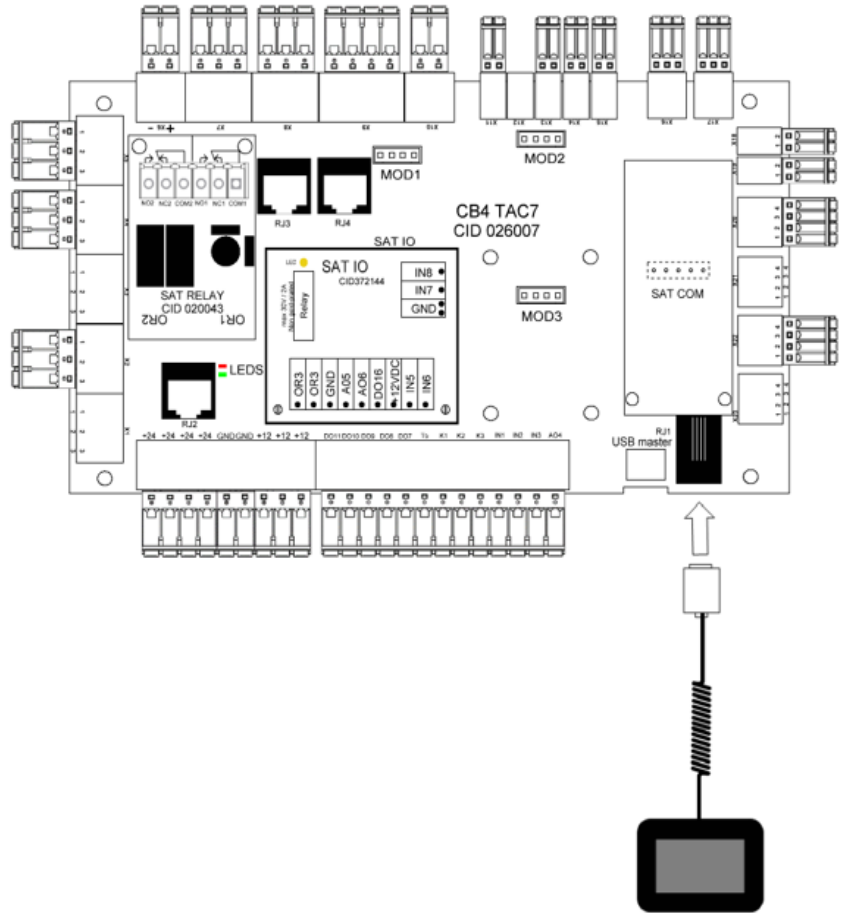

Extender cable wiring

In installation where an extender cable is necessary, this last one must conform to the RS-485 Standard with twisted pair conductors. The cable must be shielded. Conductor Area min 0.2 mm². The total length must not exceed 100 meters.

2 pairs connected to RJ12 connectors at cable extremities, straight wired. Pinout for each connector as in figure below (colors are indicative for the wires of the extender cable):

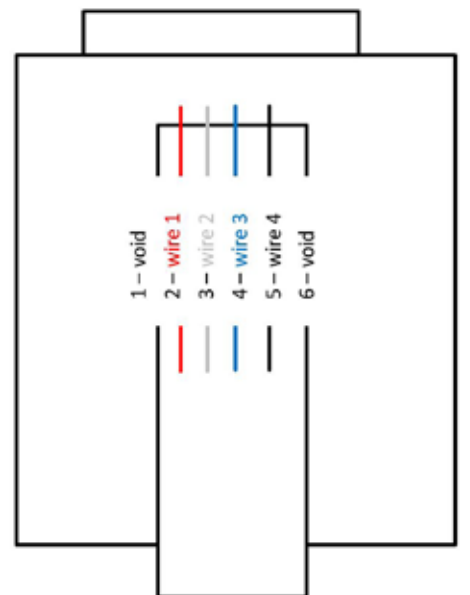

Electrical cable: Installers need to foresee extra electrical cable length for easier future maintenance of the AHU.

DAMPER CONNECTION

SMO1

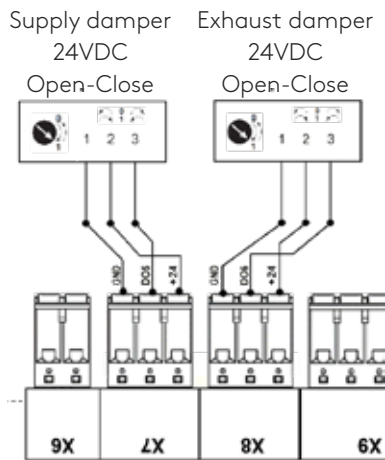

SMO2

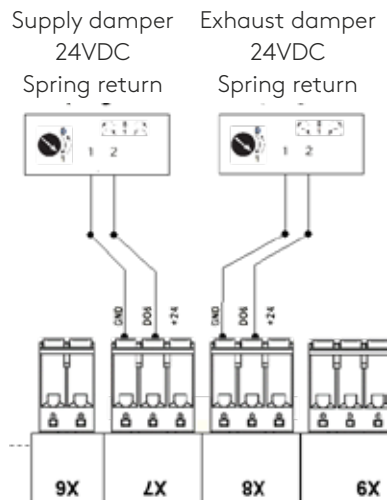

X7 = Damper 1 (Exhaust)
X8 = Damper 2 (Supply)

If the cables have been properly connected, the damper will open correctly.

Otherwise, it will be closed when the unit is in operation. To correct the error, simply turn the pointer on the servo motor to the opposite position (from 1 to 0, from L to R or vice versa, depending on the version of the register).

ELECTRICAL POWER SUPPLY

	SIZE	AHU WITHOUT ACCESSORIES		ELECTRICAL HEATER	
GLOBAL RX	08	1 X 230 V	5,3 A	3 X 400 V	8,7 A
	13	1 X 230 V	7,7 A	3 X 400 V	13 A
	16	1 X 230 V	7,7 A	3 X 400 V	17,3 A
	18	3 X 400 V + N	6,5 A	3 X 400 V	21,7 A
	20	3 X 400 V + N	6,5 A	3 X 400 V	26 A
	26	3 X 400 V + N	6,5 A	3 X 400 V	32,5 A
GLOBAL RX Top	05	1 X 230 V	5,3 A	3 X 400 V	6,5 A
	08	1 X 230 V	5,3 A	3 X 400 V	8,7 A
	13	1 X 230 V	7,7 A	3 X 400 V	13 A
	16	1 X 230 V	7,7 A	3 X 400 V	17,3 A
GLOBAL PX LP	02	1 X 230 V	3,1 A	1 X 230 V	13 A
	04	1 X 230 V	3,1 A	1 X 230 V	13 A
	06	1 X 230 V	5,3 A	3 X 400 V	6,5 A
	08	1 X 230 V	5,3 A	3 X 400 V	8,7 A
	10	1 X 230 V	4,9 A	3 X 400 V	8,7 A
	12	1 X 230 V	7,7 A	3 X 400 V	13 A
	13	1 X 230 V	7,7 A	3 X 400 V	13 A
	14	1 X 230 V	7,7 A	3 X 400 V	13 A
	16	1 X 230 V	12,7 A	3 X 400 V	17,3 A
	18	1 X 230 V	12,7 A	3 X 400 V	17,3 A
GLOBAL PX	04	1 X 230 V	5,3 A	3 X 400 V	4,3 A
	05	1 X 230 V	5,3 A	3 X 400 V	4,3 A
	06	1 X 230 V	5,3 A	3 X 400 V	8,7 A
	08	1 X 230 V	5,3 A	3 X 400 V	8,7 A
	12	1 X 230 V	7,7 A	3 X 400 V	13 A
	13	1 X 230 V	7,7 A	3 X 400 V	13 A
	16	1 X 230 V	7,7 A	3 X 400 V	17,3 A
	18	1 X 230 V	12,7 A	3 X 400 V	21,7 A
	20	1 X 230 V	12,7 A	3 X 400 V	21,7 A
	24	3 X 400 V + N	6,5 A	3 X 400 V	32,5 A
26	3 X 400 V + N	6,5 A	3 X 400 V	32,5 A	
GLOBAL PX Top	05	1 X 230 V	5,3 A	3 X 400 V	4,3 A
	08	1 X 230 V	5,3 A	3 X 400 V	8,7 A
	10	1 X 230 V	7,7 A	3 X 400 V	8,7 A
	12	1 X 230 V	7,7 A	3 X 400 V	13 A
	14	1 X 230 V	7,7 A	3 X 400 V	13 A
	18	1 X 230 V	12,7 A	3 X 400 V	17,3 A



Please refer to our selection software for more detailed information of any specific lay-out or configuration.

All internal components (fans, controls, sensors, actuators...) to the control board are pre-wired at the factory. The power supply must be connected to the safety isolating switch by a qualified electrician. Earthing is obligatory according EN61557. The fuses are of D-type.

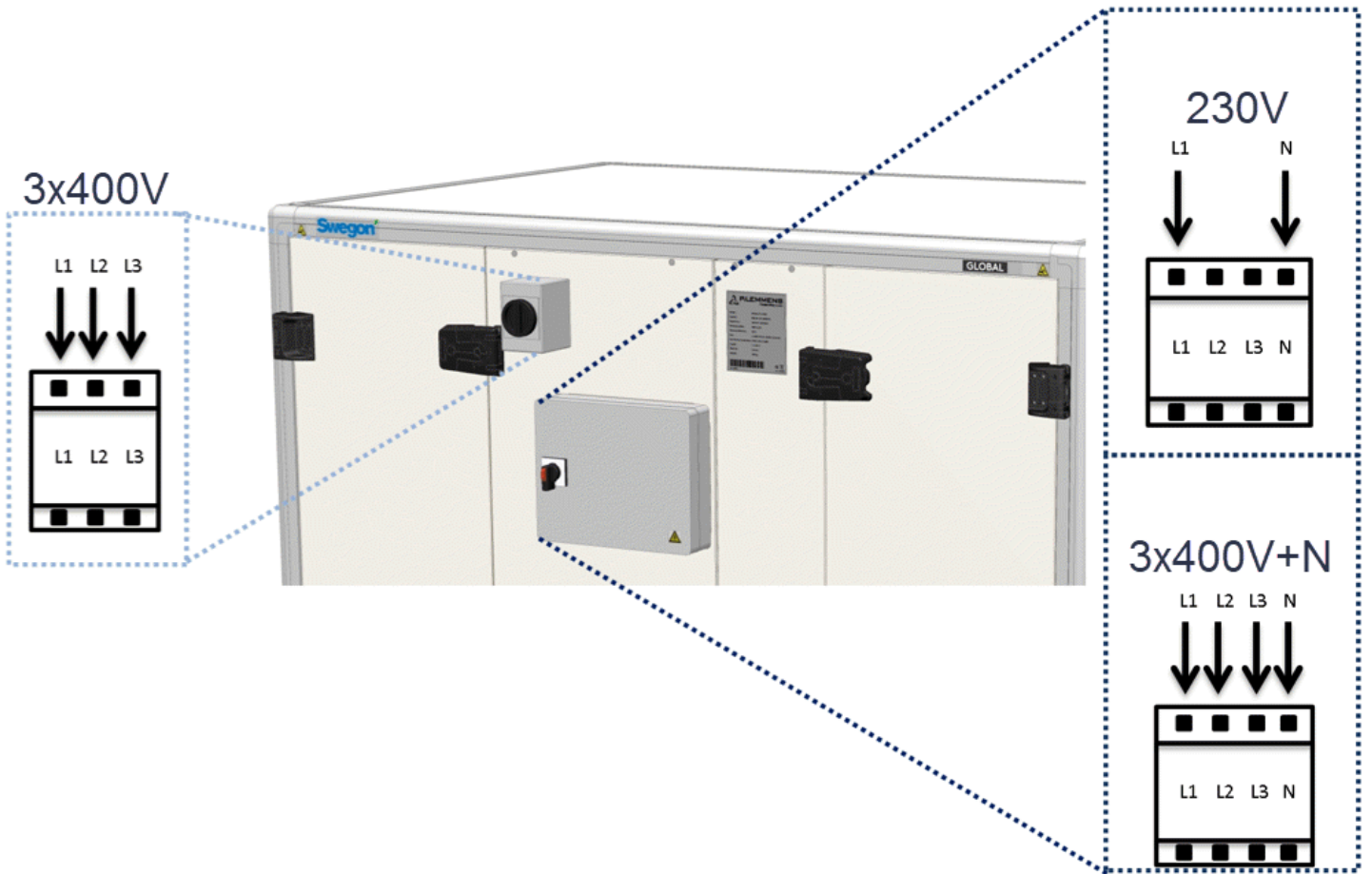



6.0 QR codes

Manuals	QR codes
OPERATION & MAINTENANCE MANUAL	
QUICK COMMISSIONING MANUAL	
FUNCTIONS MANUAL	
ALARMS MANUAL	

TAC CONTROL BOARD

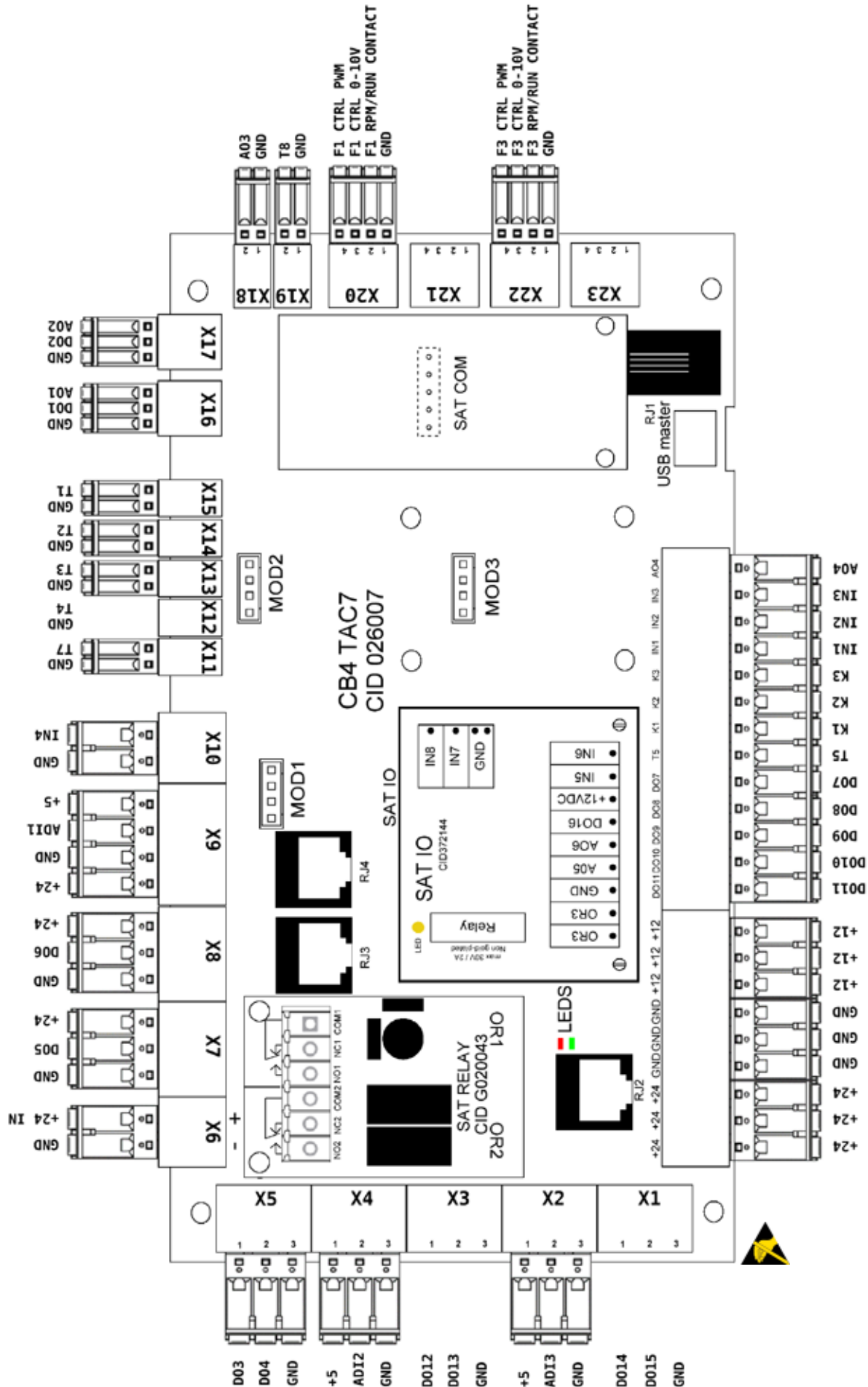

AO1 = output 0-10V for external waterborne reheater (Prewired or option)	T1 = from outdoor T° sensor (prewired)	
DO1 = KWout = output PWM for electric reheater power control (Prewired or option)	T2 = from indoor T° sensor (prewired)	
DO2 = KWIn- PX: output PWM for electric pre-heater power control (Prewired or option) RX SPEED PWM - RX	T3 = to outdoor T° sensor (prewired)	
	T4 = Waterborne pre-heater (EBAin) T° sensor (option)	
AO2 = RX SPEED 0-10V - RX (option)	T5 = supply T° sensor for waterborne reheater (IBA)/electric reheater coil (KWout) (option)	
AO3 = 0-10V output to control cooling capacity or reversible heat/cool	T7 = Waterborne reheater (IBA)/waterborne pre-heater (EBA) anti freeze protection T° sensor (option)	
AO4 = output 0-10V for internal waterborne reheater (option)	T8 = Cooling coil frost protection sensor	
DO3 = BYPASS OPEN- PX (with rotary actuator) (prewired)	IN1 + 12/24V = FIRE ALARM	
DO4 = BYPASS CLOSE - PX (with rotary actuator) (prewired)	IN2 + 12/24V = BOOST	
DO5 = DAMPER 1 (with or without spring return, I _{max} = 0.5A DC) (Prewired or option)	IN3 + 12/24V = BYPASS ACTIVATION OVERRIDE	
DO6 = DAMPER 2 (with or without spring return, I _{max} = 0.5A DC) (Prewired or option)	IN4 + GND = Drain pan full contact (only for PX LP Unit - prewired)	
DO7 = HEAT OUTPUT (open collector; V _{max} =24 VDC; I _{max} =0,1 A)	K1 + 12/24V: Airflow MODE	= m ³ /h or l/s K1
DO8 = COOL OUTPUT (open collector; V _{max} =24 VDC; I _{max} =0,1 A)	Demand/Pressure control	= START/STop
DO9 = ALARM OUTPUT (open collector; V _{max} =24 VDC; I _{max} =0,1 A)	K2 + 12/24V: Airflow control	= m ³ /h or l/s K2
DO10 = AL dPA OUTPUT (open collector; V _{max} =24 VDC; I _{max} =0,1 A)	Demand/Pressure control	= 0-10V INPUT
DO11 = FAN ON OUTPUT (open collector; V _{max} =24 VDC; I _{max} =0,1 A)	K3 + 12/24V: Airflow control	= m ³ /h or l/s K3
ADI1 = BYPASS POS - PX RX SPEED FEEDBACK - RX (prewired)	Demand/Pressure control	= % ON K3 or 0-10V INPUT
ADI2 = SUPPLY FILTER dPa	RJ1 = RJ12 connector for TACTouch (option)	
ADI3 = EXTRACT FILTER dPa	RJ2 = RJ12 connector for Modbus Pressure CP mode (option); Modbus Air quality sensors for demand control mode (option); Modbus Air quality sensors for BOOST in all modes (option)	
F1 = FAN 1 (SUPPLY)	RJ3 = RJ12 connector for ESENSA or GLOBAL PX LP: free; for GLOBAL PX/RX: Modbus Pressure sensors kit CA (prewired) and/or filters monitoring (option - prewired), on supply flow	
F3 = FAN 3 (EXHAUST)	RJ4 = RJ12 connector for Modbus Pressure sensors kit CA (prewired) and/or defrost detecting (option - prewired) and/or filters monitoring (option - prewired); NB: for GLOBAL PX/RX: sensor used for extract flow only	
SAT COM = SAT MODBUS or SAT KNX or SAT WIFI-ETHERNET - (option)		
GREEN LED ON = POWERED ON RED LED ON = ALARM		

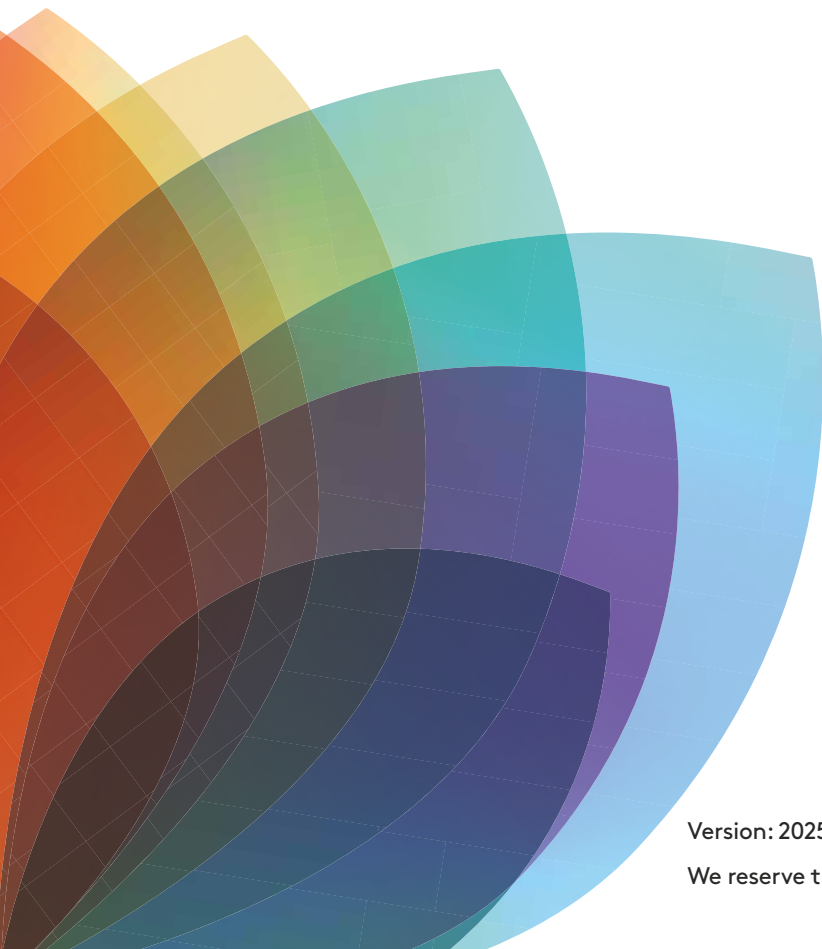

050504

Swegon 

Version: 20250528

We reserve the right for changes.