

# GLOBAL RX-PX-LP- LP OUT

## Quickguide

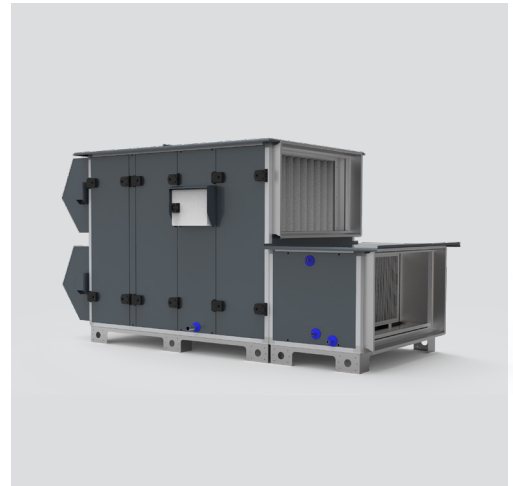
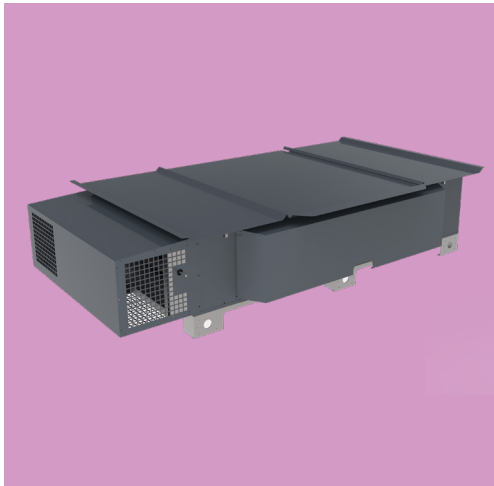
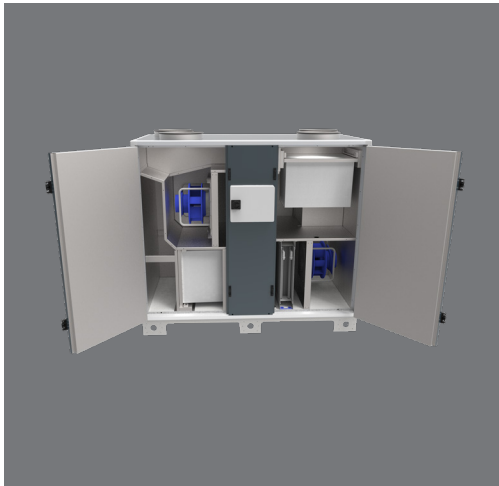
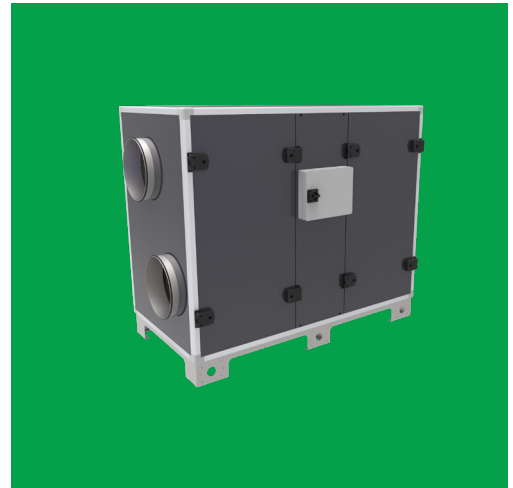
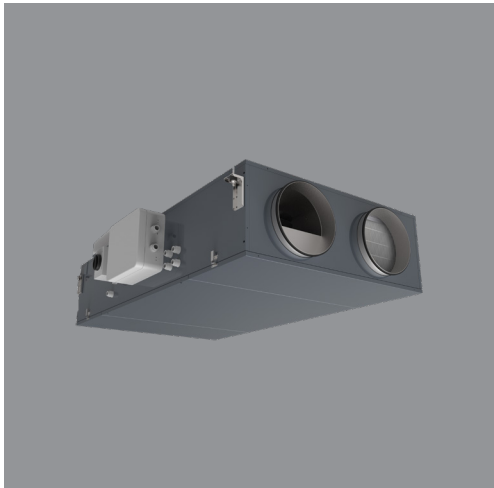
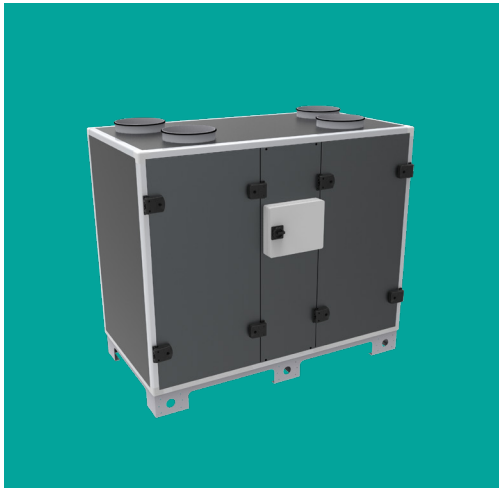

Dimensioning guide

# GLOBAL RX TOP



## RX TOP 05 - 08 -10

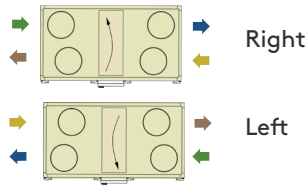

## RX TOP 12-13-14-16

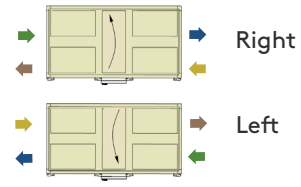

Size	RX TOP	Fan type	L (mm)	W (mm)	H (mm)	Weight (kg)	Ø (mm)	□ (mm)	Min.		Max.		Ecodesign LOT6			Filter type (EN16890)		⚡
									m³/h	l/s	m³/h	l/s	Nom. airflow (m³/s)	Effic. (EN308) *	LWA dB(A)**	Supply	Extract	
05 TOP std	comp	1530	815	1315	340	250	na	100	28	950	260	0,19	78%	52	ePM1 70%	ePM10 50%	1 x 230V / 5.3A	
05 TOP pre	comp	1530	815	1315	340	250	na	200	56	1300	360	0,19	81%	54	ePM1 70%	ePM10 50%	1 x 230V / 5.3A	
08 TOP std	comp	1530	815	1315	340	250	na	200	56	1300	360	0,25	79%	47	ePM1 70%	ePM10 50%	1 x 230V / 5.3A	
08 TOP pre	comp	1530	815	1315	340	250	na	200	56	1300	360	0,25	82%	50	ePM1 70%	ePM10 50%	1 x 230V / 5.3A	
10 TOP std	comp	1680	885	1465	400	315	na	160	44	1600	440	0,31	79%	47	ePM1 70%	ePM10 50%	1 x 230V / 4.9A	
10 TOP pre	comp	1680	885	1465	400	315	na	160	44	1600	440	0,31	82%	49	ePM1 70%	ePM10 50%	1 x 230V / 4.9A	
12 TOP std	comp	1680	885	1465	390	opt	593 x 354	200	56	2000	550	0,39	77%	50	ePM1 70%	ePM10 50%	1 x 230V / 7.7A	
12 TOP pre	comp	1680	885	1465	390	opt	593 x 354	200	56	2000	550	0,39	80%	53	ePM1 70%	ePM10 50%	1 x 230V / 7.7A	
13 TOP std	comp	1680	995	1465	420	opt	593 x 408	200	56	2300	630	0,45	79%	48	ePM1 70%	ePM10 50%	1 x 230V / 7.7A	
13 TOP pre	comp	1680	995	1465	420	opt	593 x 408	200	56	2300	630	0,45	82%	49	ePM1 70%	ePM10 50%	1 x 230V / 7.7A	
14 TOP std	comp	1680	1182	1465	460	opt	593 x 503	250	69	2900	800	0,56	79%	48	ePM1 70%	ePM10 50%	1 x 230V / 7.7A	
14 TOP pre	comp	1680	1182	1465	460	opt	593 x 503	250	69	2900	800	0,56	82%	49	ePM1 70%	ePM10 50%	1 x 230V / 7.7A	
16 TOP std	comp	1680	1182	1465	470	opt	593 x 503	300	83	3050	840	0,59	80%	48	ePM1 70%	ePM10 50%	1 x 230V / 7.7A	
16 TOP pre	comp	1680	1182	1465	470	opt	593 x 503	300	83	3050	840	0,59	83%	49	ePM1 70%	ePM10 50%	1 x 230V / 7.7A	

std = standard heat exchanger /pre = premium heat exchanger / comp = composite (aluminium available in option) / opt = IRS adapter available in option / tba = to be advised  
 Controls : All units are equipped with the smart control system TAC with optional connectivity by BACNET, Modbus RTU, TCP IP over Ethernet, TCP IP over Wifi, KNX.

Hardware : All units have a casing in RAL 7016, are insulated with 50mm Rockwool and can be delivered as left or right units. Operating temperatures are from -20°C to +50°C

\*Heat exchanger efficiency dry bulb (EN308) at nominal airflow

\*\*Casing radiated sound power level at nominal airflow and 200 Pa of external pressure

# GLOBAL LP

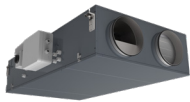

## LP 02 - 18

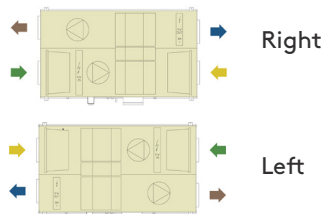

Size	LP	Fan type	L (mm)	W (mm)	H (mm)	Weight (kg)	Supply Exhaust	Extract Outdoor	Supply Exhaust	Extract Outdoor	Min.		Max.		Ecodesign LOT6			Filter type (EN16890)		⚡
							Ø (mm)	Ø (mm)	□ (mm)	□ (mm)	m³/h	l/s	m³/h	l/s	airflow	ic. (EN308)	LWA dB(A)	Supply	Extract	
02	comp	1300	890	350	130	200	200	na	na	100	30	580	160	0,11	81	58	ePM10 55%	ePM10 55%	1 x 230V / 3.1A	
04	comp	1300	1100	350	150	250	250	na	na	100	30	650	180	0,13	82	58	ePM10 55%	ePM10 55%	1 x 230V / 3.1A	
06	comp	2100	1050	435	240	315	315	na	na	200	55	1000	270	0,19	82	64	ePM1 70%	ePM10 50 %	1 x 230V / 5.3A	
08	comp	2100	1300	435	280	315	315	na	na	200	55	1420	390	0,28	82	61	ePM1 70%	ePM10 50 %	1 x 230V / 5.3A	
10	comp	2100	1600	435	340	opt	opt	400 x 300	800 x 300	250	70	1800	500	0,35	82	61	ePM1 70%	ePM10 50 %	1 x 230V / 4.9A	
12	comp	2250	1700	510	390	opt	opt	400 x 300	800 x 400	300	80	2200	610	0,43	81	60	ePM1 70%	ePM10 50 %	1 x 230V / 7.7A	
13	comp	2250	1700	510	390	opt	opt	500 x 400	800 x 400	300	80	2550	700	0,5	81	61	ePM1 70%	ePM10 50 %	1 x 230V / 7.7A	
14	comp	2250	1940	510	430	opt	opt	500 x 400	1000 x 400	300	80	2870	790	0,56	81	61	ePM1 70%	ePM10 50 %	1 x 230V / 7.7A	
16	comp	2900	1935	660	610	opt	opt	700 x 500	700 x 500	400	110	3300	920	0,64	85	60	ePM1 70%	ePM10 50 %	1 x 230V / 12.7A	
18	comp	2900	1935	660	610	opt	opt	700 x 500	700 x 500	400	110	3720	1030	0,72	85	62	ePM1 70%	ePM10 50 %	1 x 230V / 12.7A	

comp = composite (aluminium available in option) / opt = IRS adapter available in option / tba = to be advised / na = not available as standard feature

Controls : All units are equipped with the smart control system TAC5 with optional connectivity by BACNET, Modbus RTU, TCP IP over Ethernet, TCP IP over Wifi, KNX.

Hardware : All units have a casing in RAL 7016, are insulated with 30mm Rockwool and can be delivered as left or right units. Operating temperatures are from -20°C to +50°C

\*Heat exchanger efficiency dry bulb (EN308) at nominal airflow

\*\*Casing radiated sound power level at nominal airflow and 200 Pa of external pressure

# GLOBAL RX



## RX 05 - 26

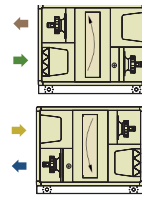

Right

Left

Size RX	Fan type	L (mm)	W (mm)	H (mm)	Weight (kg)	Ø (mm)	□ (mm)	Min.		Max.		Ecodesign LOT6			Filter type (EN16890)		⚡
								m³/h	l/s	m³/h	l/s	Nom. airflow (m³/s)	Effic. (EN308) *	LWA dB(A)**	Supply	Extract	
05 std	comp	1530	815	1315	330	315	na	200	56	1100	300	0,21	77%	50	ePM1 70%	ePM10 50%	1 x 230V / 5.3A
05 pre												0,21	80%	53			
08 std	comp	1530	815	1315	330	315	na	200	56	1600	440	0,31	77%	46	ePM1 70%	ePM10 50%	1 x 230V / 5.3A
08 pre												0,31	80%	49			
10 std	comp	1680	885	1465	380	400	na	250	69	1650	450	0,32	79%	47	ePM1 70%	ePM10 50%	1 x 230V / 4.9A
10 pre												0,32	82%	48			
12 std	comp	1680	885	1465	360	opt	808 x 583	300	83	2250	620	0,44	76%	49	ePM1 70%	ePM10 50%	1 x 230V / 7.7A
12 pre												0,44	79%	51			
13 std	comp	1680	995	1465	390	opt	918 x 583	300	83	2800	770	0,54	77%	48	ePM1 70%	ePM10 50%	1 x 230V / 7.5A
13 pre												0,54	81%	49			
14 std	comp	1680	1182	1465	420	opt	1105 x 583	300	83	3050	840	0,59	79%	48	ePM1 70%	ePM10 50%	1 x 230V / 7.8A
14 pre												0,59	82%	49			
16 std	comp	1680	1182	1465	430	opt	1105 x 583	300	83	3200	880	0,62	80%	48	ePM1 70%	ePM10 50%	3 x 400V + N / 6.3A
16 pre												0,62	83%	49			
18 std	comp	1880	1382	1725	610	opt	1305 x 713	600	167	4500	1250	0,88	80%	51	ePM1 70%	ePM10 50%	3 x 400V + N / 6.7A
18 pre												0,88	83%	53			
20 std	comp	1880	1382	1725	610	opt	1305 x 713	600	167	5400	1500	1,05	78%	52	ePM1 70%	ePM10 50%	3 x 400V + N / 6.5A
20 pre												1,05	82%	53			
24 std	comp	1880	1640	1725	670	opt	1563 x 713	600	167	6350	1760	1,23	79%	55	ePM1 70%	ePM10 50%	3 x 400V + N / 6.5A
24 pre												1,23	82%	54			
26 std	comp	1880	1640	1725	680	opt	1563 x 713	600	167	6900	1910	1,34	79%	55	ePM1 70%	ePM10 50%	3 x 400V + N / 6.7A
26 pre												1,34	83%	55			

std = standard heat exchanger / pre = premium heat exchanger / comp = composite (aluminium available in option) / tba = to be advised

Controls : All units are equipped with the smart control system TAC with optional connectivity by BACNET, Modbus RTU, TCP IP over Ethernet, TCP IP over Wifi, KNX.

Hardware : All units have a casing in RAL 7016, are insulated with 50mm Rockwool and can be delivered as left or right units. Operating temperatures are from -20°C to +50°C

\*Heat exchanger efficiency dry bulb (EN308) at nominal airflow

\*\*Casing radiated sound power level at nominal airflow and 200 Pa of external pressure

# GLOBAL LP OUT

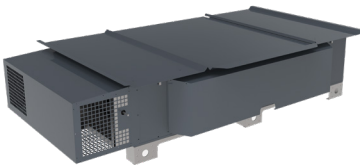

## LP 08 - 10

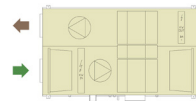

Right

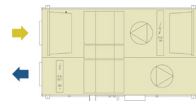

Left

Size LP	Fan type	L with I/O box (mm)	L without I/O box (mm)	H with additional feet (mm)	H with standard baseframe (mm)	W (mm)	Weight (kg)	Supply Exhaust	Extract Outdoor	Supply Exhaust	Extract Outdoor	Min.		Max.		Ecodesign LOT6			Filter type (EN16890)		⚡
								Ø (mm)	Ø (mm)	□ (mm)	□ (mm)	m³/h	l/s	m³/h	l/s	Nom. airflow (m³/s)	Effic. (EN308) *	LWA dB(A)**	Supply	Extract	
08	comp	2540	2310	795	590	1450	275	315	315	na	na	200	55	1420	390	0,28	82	61	ePM1 70%	ePM10 50 %	1 x 230V / 5.3A
10	comp	2540	2310	795	590	1750	335	opt	opt	400 x 300	800 x 300	250	70	1800	500	0,35	61	61	ePM1 70%	ePM10 50 %	1 x 230V / 4.9A

comp = composite (aluminium available in option) / opt = IRS adapter available in option / tba = to be advised / na = not available as standard feature

Controls : All units are equipped with the smart control system TAC with optional connectivity by BACNET, Modbus RTU, TCP IP over Ethernet, TCP IP over Wifi, KNX.

Hardware : All units have a casing in RAL 7016, are insulated with 30mm Rockwool and can be delivered as left or right units. Operating temperatures are from -20°C to +50°C

\*Heat exchanger efficiency dry bulb (EN308) at nominal airflow

\*\*Casing radiated sound power level at nominal airflow and 200 Pa of external pressure

# GLOBAL PX

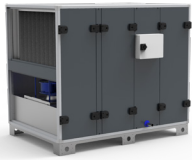

## PX 04 - 26

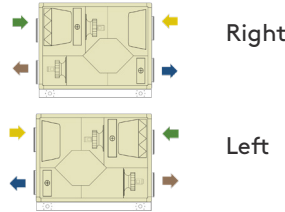

Size	PX	Fan type	L (mm)	W (mm)	H (mm)	Weight (kg)	Ø (mm)	□ (mm)	Min.		Max.		Ecodesign LOT6			Filter type (EN16890)		⚡
									m³/h	l/s	m³/h	l/s	Nom. airflow (m³/s)	Effic. (EN308) *	LWA dB(A) **	Supply	Extract	
04	comp	1680	610	1465	330	315	na	200	55	800	220	0,16	83%	54	ePM1 70%	ePM10 50%	1 x 230V / 5.3A	
05	comp	1680	610	1465	330	315	na	200	55	1000	270	0,19	82%	54	ePM1 70%	ePM10 50%	1 x 230V / 5.3A	
06	comp	1680	815	1465	390	400	na	200	55	1400	380	0,27	83%	48	ePM1 70%	ePM10 50%	1 x 230V / 5.3A	
08	comp	1680	815	1465	400	400	na	200	55	1600	440	0,31	82%	49	ePM1 70%	ePM10 50%	1 x 230V / 5.3A	
10	comp	1680	995	1465	440	400	na	250	70	1850	510	0,36	83%	48	ePM1 70%	ePM10 50%	1 x 230V / 4.9A	
12	comp	1680	1182	1465	450	opt	1069 x 547	400	110	2300	630	0,45	83%	49	ePM1 70%	ePM10 50%	1 x 230V / 7.7A	
13	comp	1680	1182	1465	450	opt	1069 x 547	400	110	2650	730	0,52	82%	49	ePM1 70%	ePM10 50%	1 x 230V / 7.7A	
14	comp	1680	1382	1465	540	/	1269 x 547	300	85	2850	790	0,55	83%	48	ePM1 70%	ePM10 50%	1 x 230V / 7.7A	
16	comp	1680	1640	1465	610	/	1105 x 583	300	85	3250	900	0,63	83%	49	ePM1 70%	ePM10 50%	1 x 230V / 7.7A	
18	comp	1880	2015	1465	670	/	1938 x 583	400	115	4000	1110	0,78	83%	49	ePM1 70%	ePM10 50%	1 x 230V / 12.7A	
20	comp	2557	1640	1825	920	/	1563 x 713	600	170	4600	1270	0,89	82%	51	ePM1 70%	ePM10 50%	1 x 230V / 12.7A	
24	comp	2557	2015	1825	1110	/	1938 x 713	600	170	5900	1640	1,15	82%	54	ePM1 70%	ePM10 50%	3 x 400V + N / 6.5A	
26	comp	2557	2396	1825	1250	/	2318 x 713	600	170	6800	1890	1,32	82%	55	ePM1 70%	ePM10 50%	3 x 400V + N / 6.5A	

comp = composite (aluminium available in option) / opt = IRS adapter available in option / tba = to be advised

Controls : All units are equipped with the smart control system TAC with optional connectivity by BACNET, Modbus RTU, TCP IP over Ethernet, TCP IP over Wifi, KNX.

Hardware : All units have a casing in RAL 7016, are insulated with 50mm Rockwool and can be delivered as left or right units. Operating temperatures are from -20°C to +50°C

\*Heat exchanger efficiency dry bulb (EN308) at nominal airflow

\*\*Casing radiated sound power level at nominal airflow and 200 Pa of external pressure

# GLOBAL PX TOP



## PX TOP 05 - 10



## PX TOP 12 - 18



Size	PX TOP	Fan type	L (mm)	W (mm)	H (mm)	Weight (kg)	Inlet / Outlet W*H (mm)	Min.		Max.		Ecodesign LOT6			Filter type (EN16890)		⚡
								m³/h	l/s	m³/h	l/s	Nom. airflow (m³/s)	Effic. (EN308) *	LWA dB(A) **	Supply	Extract	
05	comp	1680	610	1625	340	Ø 250	200	60	950	260	0,18	83%	54	ePM1 60%	ePM10 50%	1 x 230V / 5.3A	
08	comp	1680	815	1625	400	Ø 315	200	60	1500	410	0,29	83%	49	ePM1 60%	ePM10 50%	1 x 230V / 5.3A	
10	comp	1960	815	1725	500	Ø 315	300	80	1850	510	0,36	82%	54	ePM1 60%	ePM10 50%	1 x 230V / 7.7A	
12	comp	1960	995	1725	560	500*300	300	80	2450	680	0,48	82%	49	ePM1 60%	ePM10 50%	1 x 230V / 7.7A	
14	comp	1960	1182	1725	620	600*300	300	80	2800	770	0,54	83%	48	ePM1 60%	ePM10 50%	1 x 230V / 7.7A	
18	comp	1960	1382	1725	710	800*300	400	110	3600	1000	0,7	82%	49	ePM1 60%	ePM10 50%	1 x 230V / 12.7A	

comp = composite (aluminium available in option except for size 18) / opt = IRS adapter available in option / tba = to be advised / na = not available as standard

Controls : All units are equipped with the smart control system TAC with optional connectivity by BACNET, Modbus RTU, TCP IP over Ethernet, TCP IP over Wifi, KNX.

Hardware : All units have a casing in RAL 7016, are insulated with 50mm Rockwool and can be delivered as left or right units. Operating temperatures are from -20°C

\*Heat exchanger efficiency dry bulb (EN308) at nominal airflow

\*\*Casing radiated sound power level at nominal airflow and 200 Pa of external pressure

## THE 3 MAIN OPERATING MODES

### AIRFLOW OR PRESSURE

Whether the ventilation system is operated on the basis of constant pressure or constant airflow or via a 0–10V control system depends on the area of application and the specific on-site requirements. The integrated master/slave control system ensures that operation is always well-balanced.

#### Constant airflow mode

A typical area of application is non-residential buildings, e.g. offices and business premises as well as schools, nurseries and sports halls with stable volumes of air.

#### Demand control mode

Alternatively, the airflow can be automatically adapted in line with the ventilation requirements and on a user-specific basis via the 0–10 V input, e.g. by means of a CO<sub>2</sub> sensor, or the control system can be used via the customer's building service management/instrumentation and control system.

#### Constant pressure mode

A prime example is undoubtedly apartment buildings with the opportunity to control the ventilation in individual apartments separately. The pressure remains constant even when the ventilation is increased or decreased in one apartment as required, by means of an airflow control unit.

The airflow stays the same in all the other apartments, i.e. the ventilation system always runs within the ideal range. An external pressure sensor is required for constant pressure mode.

### THE ADVANTAGES IN

#### DETAIL

- Sufficiently high reserve pressure
- Constant airflow
- Demand control: constant airflow linked to a 0–10 V signal
- Constant pressure via an external pressure sensor

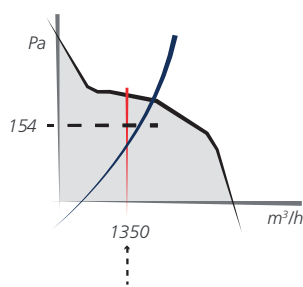

#### Constant Airflow mode

The airflow is kept constant, irrespective of external changes in pressure.

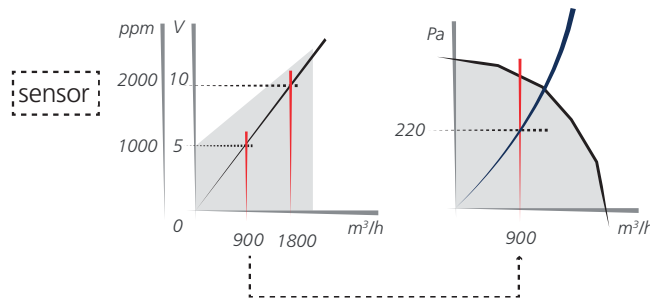

#### Demand control mode

A linear voltage/airflow ratio. The airflow can be controlled via a 0–10 V signal.

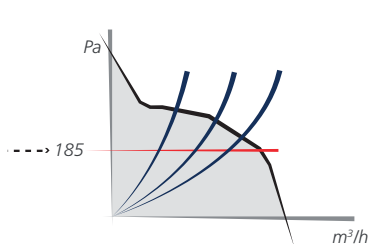
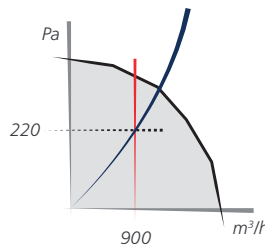

#### Constant pressure mode

The pressure is kept constant, regardless of external changes in pressure. A pressure sensor is required.

## CASING PERFORMANCES

The casing of the GLOBAL units is fabricated of aluminum profiled sections held together by synthetic corners. The outer skin is made of painted steel sheet, RAL7016. The inner skin is made of galvanized sheet steel. The panel thickness is 50mm (GLOBAL RX & PX) or 30mm (GLOBAL LP) with intervening insulation consisting of mineral wool. The doors are hung on four hinges, two on every side, with integrated handles (GLOBAL RX & PX). GLOBAL LP features a sliding rail.

	PX	PX TOP	LP	LP OUT	RX	RX TOP
Mechanical resistance class of the envelope	D1 (R)	D1 (R)	D1 (R)	D1 (R)	D1 (R)	D1 (R)
Thermal transmittance class U	T3 (M) Optionally: T2	T3 (M) Optionally: T2	T3 (M)	T3 (M)	T3 (M) Optionally: T2	T3 (M) Optionally: T2
Thermal bridge class Kb	TB2 (M)	TB2 (M)	TB2 (M)	TB2 (M)	TB2 (M)	TB2 (M)
Airtightness of the envelope class (exhaust and supply airstreams)	L2 (R)	L2 (M)	L2 (R)	L2 (R)	L2 (R)	L2 (R)
Airtightness around the filters class (exhaust and supply airstreams)	F9 (R)	F9 (R)	F9 (R)	F9 (R)	F9 (R)	F9 (R)

(\*) T/TB Classes according to tests on modelboxes (M), F/L/D classes according to tests on real units (R)

# TECHNICAL OVERVIEW

EC PLUG FAN WITH  
COMPOSITE FAN BLADES  
(ALUMINUM BLADES  
OPTIONAL)

1

FRESH AIR FILTER  
ePM1 $\geq$ 60%  
FILTER CLASS

2

EXTRACT AIR FILTER  
ePM10 $\geq$ 50%  
FILTER CLASS

3

INTEGRATED TAC  
CONTROLLER

4

HIGH EFFICIENCY  
COUNTERFLOW PLATE  
HEAT EXCHANGER

5

HIGH EFFICIENCY ROTARY  
HEAT EXCHANGER

6

STEPLESS ROTOR DRIVE  
WITH SOLDERED BELT

7

MODULATING  
100% BYPASS

8

STAINLESS STEEL  
DRAIN PAN

9

BASE FRAME FOR EASY  
ON SITE TRANSPORT

10

EASY ACCESS HINGES

11

EASY ACCESS  
SLIDING RAILS

12

INTEGRATED POST  
HEATING (WATER/  
ELECTRICAL)

13

INTEGRATED PREHEATING  
(ELECTRICAL)

14

SILENCER

15

## GLOBAL RX TOP

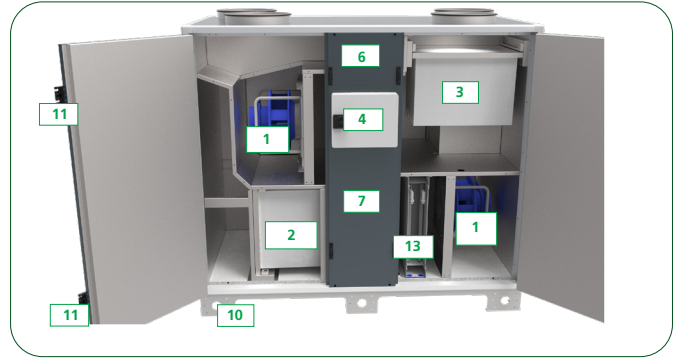

## GLOBAL RX



## GLOBAL PX TOP

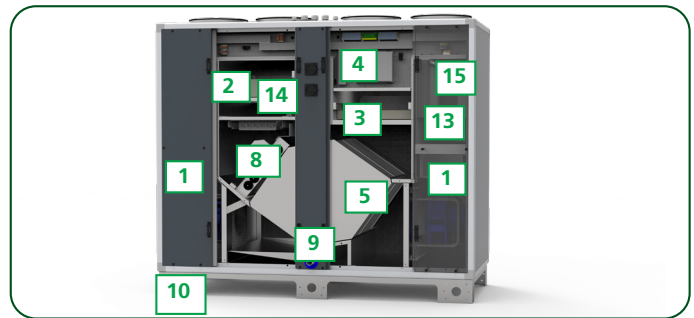

## GLOBAL PX

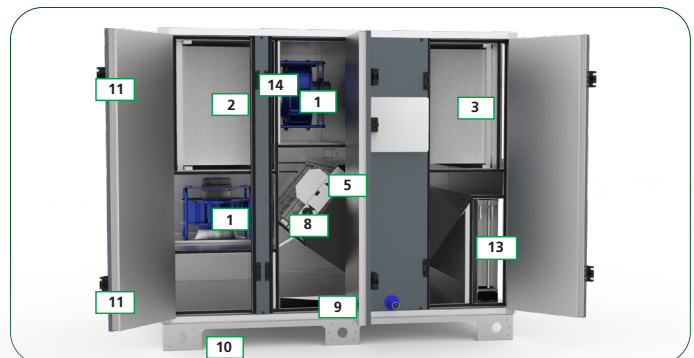

# TECHNICAL OVERVIEW

- EC PLUG FAN WITH COMPOSITE FAN BLADES (ALUMINUM BLADES OPTIONAL) 1
  
- FRESH AIR FILTER ePM1≥60% FILTER CLASS 2
  
- EXTRACT AIR FILTER ePM10≥50% FILTER CLASS 3
  
- INTEGRATED TAC CONTROLLER 4
  
- HIGH EFFICIENCY COUNTERFLOW PLATE HEAT EXCHANGER 5
  
- HIGH EFFICIENCY ROTARY HEAT EXCHANGER 6
  
- STEPLESS ROTOR DRIVE WITH SOLDERED BELT 7
  
- MODULATING 100% BYPASS 8
  
- STAINLESS STEEL DRAIN PAN 9
  
- BASE FRAME FOR EASY ON SITE TRANSPORT 10
  
- EASY ACCESS HINGES 11
  
- EASY ACCESS SLIDING RAILS 12
  
- INTEGRATED POST HEATING (WATER/ELECTRICAL) 13
  
- INTEGRATED PREHEATING (ELECTRICAL) 14
  
- SILENCER 15

## GLOBAL LP

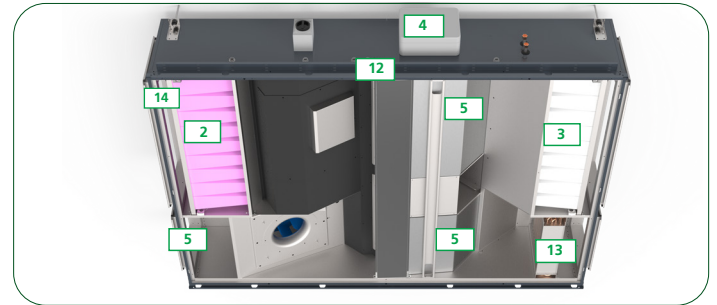

## GLOBAL LP OUT

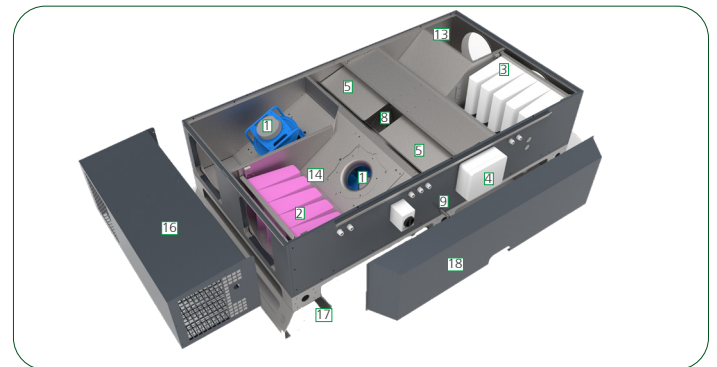

- BOX I/O (INLET / OUTLET) 16
  
- ADDITIONAL LEGS 17
  
- PROTECTION COVER 18

# OPTIONS & ACCESSORIES

Option	Shortcut	Category		RX TOP	RX	PX	LP	LP OUT	PX TOP
TACtouch	HMI	Controls		x	x	x	x	x	x
BACnet gateway	BACnet	Controls		x	x	x	x	x	x
Modbus RTU	Modbus	Controls		x	x	x	x	x	x
Ethernet	Ethernet	Controls		x	x	x	x	x	x
Wifi	Wifi	Controls		x	x	x	x	x	x
SAT 3*	SAT	Controls		x	x	x	x	x	x
KNX	KNX	Controls		x	x	x	x	x	x
Internal water post heating	IBA	Coils		x	x	x	x	x	x
Internal electrical pre heating	Kwin	Coils				x	x	x	x
Internal electrical post heating	Kwout	Coils		x	x	x	x	x	x
External insulated casing for coils	ECA	Coils		x	x	x	x	x	x
Coils for external casing	EBA	Coils		x	x	x	x	x	x
Roof	OUT	Outdoor			x	x			
Motorised damper	CT	Outdoor		x	x	x	x**	x**	x
Air inlet	AUi	Outdoor			x	x			
Air Outlet	AUe	Outdoor			x	x			
BOX I/O***	I/O	Outdoor						x	
ADDITIONAL LEGS***		Outdoor						x	
Flexible sleeves	MS	Adapters		x	x	x	x	x	x
Circular adapters	IRS	Adapters		x	x	x	x	x	x
Prefilter G4	G4	Filters		x	x	x			x
Filter kits	Filters	Filters		x	x	x	x	x	x
Condensate pump	Pump	Others					x	x	
Silencer	GD	Others							x

\* Only available for GLOBAL PX/PX TOP/LP/LP OUT

\*\* Option for GLOBAL LP / LP OUT - not mounted

\*\*\* Only available for GLOBAL LP OUT



Version: 20220421

We reserve the right for changes.

**Swegon** 