

COLIBRI Ceiling VF

Square ceiling diffuser with nozzles for supply air with variable flow



QUICK FACTS

- Circular nozzle pattern
- Suitable for VAV and DCV applications
- Manages large temperatures below room temperature (High ΔT)
- Fast and easy installation and commissioning through Swegon Quick Access
- 100% flexible distribution pattern
- Designed for modular suspended ceiling
- Used together with the REACT ALS commissioning box for variable flow regulation
- Commissioning box ALS with one- or two-dimensional changes between duct and air diffuser connection
- ADAPTER for suspended ceiling system
- Standard colour White RAL 9003
 - 5 alternative standard colours
 - Other colours upon request

AIR FLOW - SOUND PRESSURE ROOM (Lp10A) *)							
COLIBRI Ceiling VF Size		25 dB (A)		30 dB (A)		35 dB (A)	
		l/ s	m ³ /h	l/ s	m ³ /h	l/ s	m ³ /h
250-600		73	263	86	310	101	364
315-600		93	335	109	392	127	457
COLIBRI Ceiling VF Size	REACT ALS Size	25 dB (A)		30 dB (A)		35 dB (A)	
		l/ s	m ³ /h	l/ s	m ³ /h	l/ s	m ³ /h
250-600	160-250	62	223	73	263	87	313
315-600	250-315	93	335	109	392	127	457
COLIBRI Ceiling VF Size	ALS Size	25 dB (A)		30 dB (A)		35 dB (A)	
		l/ s	m ³ /h	l/ s	m ³ /h	l/ s	m ³ /h
250-600	160-250	62	223	73	263	87	313
250-600	200-250	66	238	78	281	91	328
315-600	200-315	84	302	98	353	115	414
315-600	250-315	89	320	103	371	119	428

Data is specified for supply air with an open damper when a REACT ALS or ALS commissioning box is used.

*) Lp10A = Sound pressure incl. A-filter with 4 dB room attenuation and 10 m² room absorption area.

Contents

Technical description	3
Design	3
Material and surface treatment	3
Accessories	3
Planning	3
Installation	3
Commissioning with ALS	4
Maintenance.....	4
Environment	4
Sizing	5
Sound data – Air diffuser only.....	5
Sound data – Air diffuser with REACT ALS.....	5
Sound data – Air diffuser with ALS	5
Sizing diagram	6
Dimensions and weights.....	8
Nozzle pattern and nozzle settings.....	9
Specification.....	10
Specification text.....	10

Technical description

Design

- The square supply air diffuser COLIBRI Ceiling VF comprises a backing box and a diffuser face with rotatable nozzles in a circular pattern.
- The diffuser face is hung on hinges on one side and secured by springs on the opposite side.
- Quick Access gives simpler and faster handling during installation, commissioning and cleaning, see Figure 1.

Material and surface treatment

The backing box and diffuser face are made of sheet steel. The sleeve coupling is made of galvanised sheet steel. The interior and exterior of the air diffuser is painted.

- Standard colour:
 - White semi-gloss, lustre 40, RAL 9003/NCS S 0500-N
 - Alternative standard colours:
 - Silver gloss, lustre 80, RAL 9006
 - Grey aluminium gloss, lustre 80, RAL 9007
 - White semi-gloss, lustre 40, RAL 9010
 - Black semi-gloss, lustre 35, RAL 9005
 - Grey semi-gloss, lustre 30, RAL 7037
 - Non-painted finish and other colours available on request.
- The nozzles are made of plastic (PP-polypropylene).

Accessories

Commissioning boxes

REACT ALS/ALS

- The commissioning box is made of galvanized sheet steel.
- Removable commissioning damper, fixed measurement tappings.
- Sound-absorbing material*) with reinforced surface layer.
- Tightness class C on the housing according to SS-EN 12237.
- The commissioning box ALS is available with 1 or 2 changes in dimension between the inlet and outlet.

*) Fire resistance rated to B-s1,d0 in accordance with EN ISO 11925-2

Frame

SAR K

- For aesthetic installation of a lowered diffuser face.

Adapter

ADAPTER

For adaptation to various variants and makes of systemised false ceilings: Ecophon, Gyproc, Dampa, etc. Also used for adaptation to optional sizes of lay-in ceilings, for instance 625 x 625 or 675 x 675. Specification can be found in the product sheet for ADAPTER.

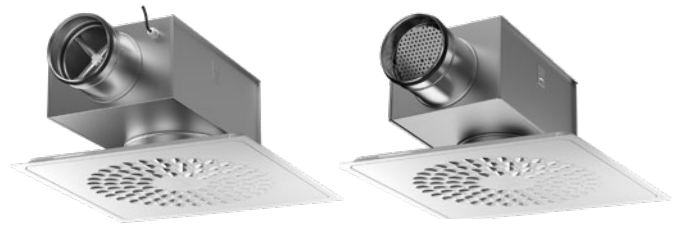

COLIBRI Ceiling VF with REACT ALS COLIBRI Ceiling VF with ALS

Planning

- COLIBRI Ceiling VF has the dimensions 595 x 595 mm in all connection sizes.
- The air diffuser is easy to install in modular suspended ceilings with modular dimensions of 600 x 600 mm.

Installation

- To dismantle the diffuser face, insert a thin object, for example a Quick Access card, in between the diffuser face and the backing box in order to release the springs. Slide the card from the centre out towards the corners, see Figure 1.
- The inlet spigot of the backing box can be secured to the connecting duct by means of screws or blind rivets.
- For flush-mounting in fixed suspended ceilings, the air diffuser is secured to the building structure by means of screws through either the sides or top of the backing box.
- Secure the air diffuser in the correct position with screws or blind rivets in the underside of the commissioning box.
- For mounting in modular suspended ceilings, it is advisable to select air diffusers with outer dimensions of 595 x 595 mm. Position these directly in the T-bar framework, and then secure them to the duct system or to the commissioning box.
- When a REACT ALS or ALS commissioning box is used, it must be secured to the building structure by means of hangers or mounting brackets.
- The distance between the commissioning box and the air diffuser can be increased up to 500 mm with a circular duct, without having to lengthen the measuring tubes and damper adjustment cords. See figure 2.

Commissioning with ALS

- Commissioning should be carried out with the diffuser face mounted.
- The measuring tubes and damper adjustment cords are pulled out through the diffuser face.
- Connect a pressure gauge to the measuring tube/tubes.
- The red and the blue tubes respectively from the ALS commissioning box of the one or two-step version are used for supply air.
- The rated coefficient of performance of the air diffuser can be used in a calculation to determine the required commissioning pressure.
- The adjusted damper position is saved by tying together the damper cord in an adjustment knot.
- Measurement accuracy and straight section requirement before the commissioning box. See Figure 2.
- Length of straight section of duct depends on type of obstruction upstream of the commissioning box.
- Figure 2 shows a bend, a change in dimension and T-piece.
- Other types of disturbances require at least $2xD$ straight section ($D =$ connection dimension) to obtain a measurement accuracy of $\pm 10\%$ on the flow.
- The K-factor is specified on the product's identification label, as well as in the relevant commissioning instructions at www.swegon.com.

Maintenance

- The air diffuser can be cleaned, if necessary, using luke-warm water with dishwashing detergent.
- Alternatively a vacuum cleaner and brush nozzle is used.
- The duct system can be reached for cleaning by opening the diffuser face. If a REACT ALS or ALS commissioning box is used, pull the distributor plate aside and then grip and twist the damper unit from of its mounting.

Environment

The Building Materials Declaration can be downloaded from www.swegon.com.

Installation

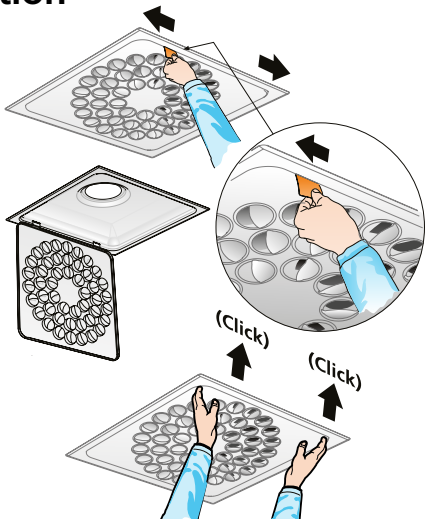

Figure 1. Quick Access, dismantling the diffuser face.

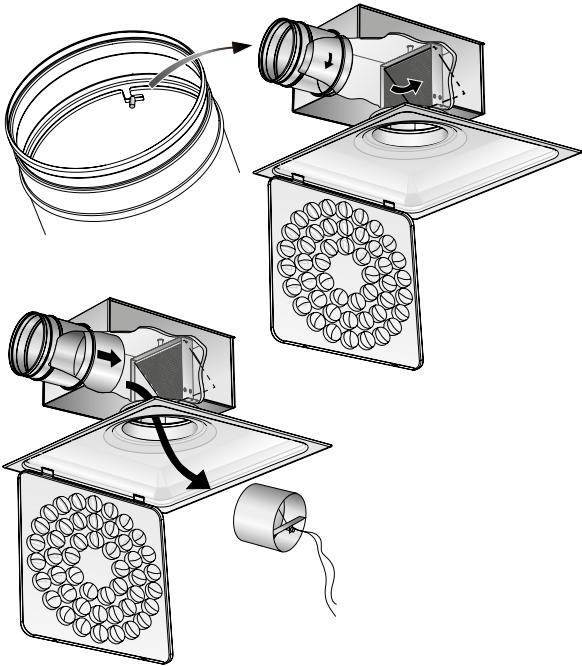

Figure 3. Dismantling the damper when using REACT ALS and ALS commissioning box.

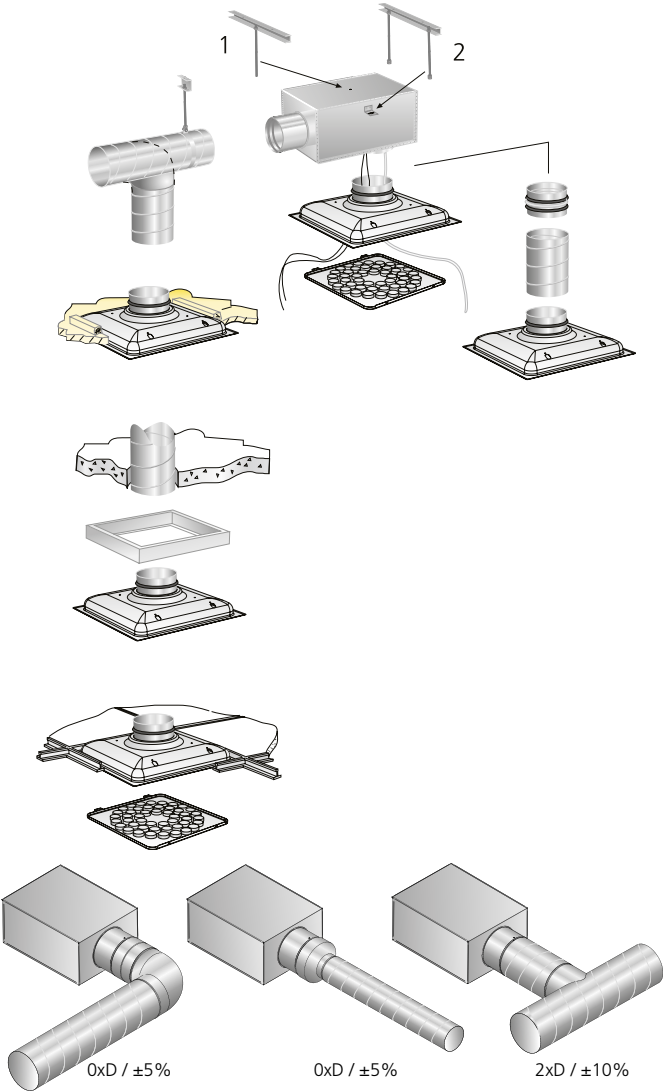

Figure 2. Installation options for the ALS commissioning box. See the REACT ALS product sheet for installation options with active commissioning box.

Sizing

- Sound pressure level dB(A) applies to rooms with an equivalent sound absorption area of 10 m².
- Sound attenuation (ΔL) below is shown in the octave band. Orifice attenuation is included in the values.
- The throw length $l_{0,2}$ is measured under isothermal discharge conditions.
- The recommended max. permissible temperature below room temperature is 14 K.

- To calculate the air stream diffusion, air velocities in the occupied zone or sound levels in rooms with other dimensions, please refer to our calculation software available on www.swegon.com.

L_w = Sound power level

L_{p10A} = Sound pressure level dB (A)

K_{ok} = Correction for producing the L_w values in the octave band

$L_w = L_{p10A} + K_{OK}$ gives the frequency divided octave band

Sound data – Air diffuser only

COLIBRI Ceiling VF – Supply air

Sound power level L_w (dB)

Table K_{ok}

Size	Mid-frequency (octave band) Hz							
	63	125	250	500	1000	2000	4000	8000
250-600	-5	-1	1	4	0	-11	-26	-28
315-600	0	0	-1	2	2	-11	-27	-29
Tol. ±	2	2	2	2	2	2	2	2

Sound attenuation ΔL (dB)

Table ΔL

Size	Mid-frequency (octave band) Hz							
	63	125	250	500	1000	2000	4000	8000
250-600	16	11	5	4	2	3	4	4
315-600	14	9	4	2	2	2	3	3
Tol. ±	2	2	2	2	2	2	2	2

Sound data – Air diffuser with REACT ALS active commissioning box

COLIBRI Ceiling VF + REACT ALS – Supply air

Sound power level L_w (dB)

Table K_{ok}

Size	Mid-frequency (octave band) Hz							
	63	125	250	500	1000	2000	4000	8000
160-250	-2	2	-3	-7	-9	-11	-12	-5
250-350	-2	2	-3	-6	-6	-9	-12	-7
Tol. ±	2	2	2	2	2	2	2	2

Sound attenuation ΔL (dB)

Table ΔL

Size	Mid-frequency (octave band) Hz							
	63	125	250	500	1000	2000	4000	8000
160-250	15	9	9	20	19	15	16	14
250-350	13	8	10	19	16	13	16	16
Tol. ±	2	2	2	2	2	2	2	2

Sound data – Air diffuser with ALS commissioning box

COLIBRI Ceiling VF + ALS – Supply air, one step

Sound power level L_w (dB)

Table K_{ok}

Size	Mid-frequency (octave band) Hz							
	63	125	250	500	1000	2000	4000	8000
200-600	-3	6	3	3	-1	-9	-18	-23
250-600	-3	5	2	2	1	-10	-22	-26
Tol. ±	2	2	2	2	2	2	2	2

Sound attenuation ΔL (dB)

Table ΔL

Size	Mid-frequency (octave band) Hz							
	63	125	250	500	1000	2000	4000	8000
200-600	13	8	8	16	17	12	12	13
250-600	11	6	7	19	14	10	10	13
Tol. ±	2	2	2	2	2	2	2	2

COLIBRI Ceiling VF + ALS – Supply air, two steps

Sound power level L_w (dB)

Table K_{ok}

Size	Mid-frequency (octave band) Hz							
	63	125	250	500	1000	2000	4000	8000
160-600	0	7	5	2	-3	-8	-16	-20
200-600	-3	7	5	1	-1	-9	-19	-21
Tol. ±	2	2	2	2	2	2	2	2

Sound attenuation ΔL (dB)

Table ΔL

Size	Mid-frequency (octave band) Hz							
	63	125	250	500	1000	2000	4000	8000
160-600	15	9	9	20	19	15	16	14
200-600	13	8	10	19	16	13	16	16
Tol. ±	2	2	2	2	2	2	2	2

Sizing diagram

Air flow – Pressure drop – Sound level – Throw length

- The diagrams illustrate data for recessed air diffuser in a ceiling.
 - The diagrams should not be used for commissioning.
 - The dB(A) values apply to rooms with normal acoustic absorption, 4 dB room attenuation/10 m² equivalent room absorption area.
 - The dB(C) value is normally 6-9 dB higher than the dB(A) value.
 - The throw length $l_{0,2}$ is measured under isothermal discharge conditions.
 - The recommended max. permissible temperature below room temperature is 14 K.
 - To calculate the air stream diffusion, air velocities in the occupied zone or sound levels in rooms with other dimensions, please refer to our calculation software available on www.swegon.com
- ∇ = Min. flow required for obtaining sufficient commissioning pressure.
 - Low installation height generates about 3 dB(A) higher sound level than the value plotted in the graph.
 - Throw length based on rotation setting. For other adjustments, see the graphs for diffuser with REACT ALS or ALS commissioning box.

COLIBRI Ceiling VF – Air diffuser only – Supply air

COLIBRI Ceiling VF 250-600, 315-600

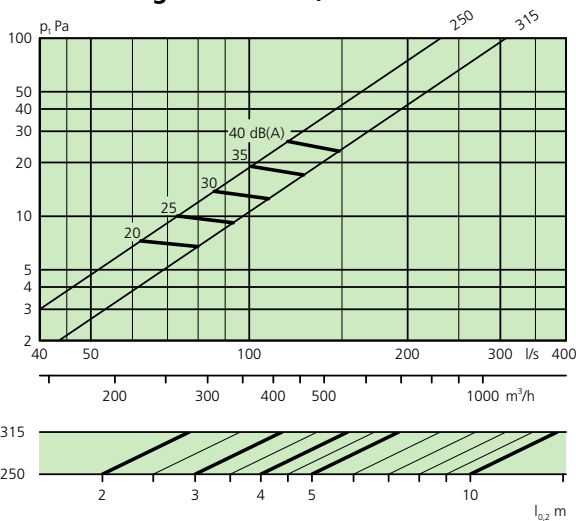

COLIBRI Ceiling VF with REACT ALS active commissioning box – Supply air

COLIBRI Ceiling VF 250-600 + REACT ALS 160-250

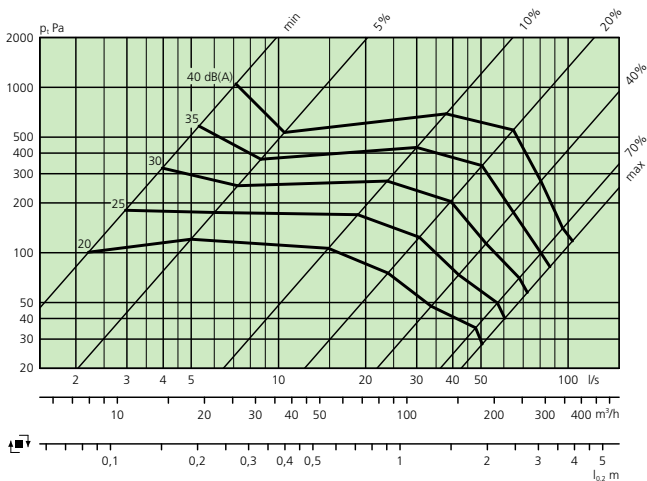

COLIBRI Ceiling VF 315-600 + REACT ALS 250-315

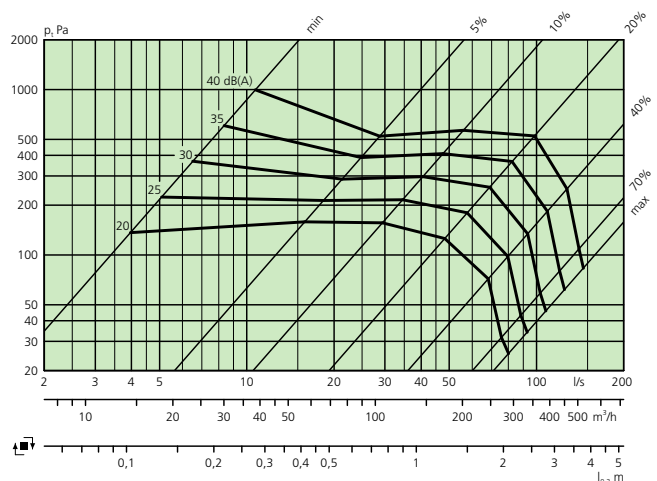

COLIBRI Ceiling VF with ALS commissioning box – Supply air

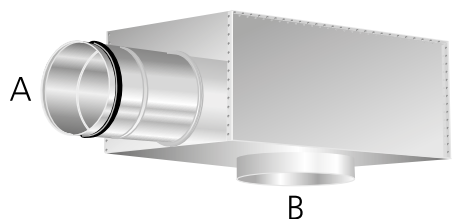

Correlation, connection dimensions.

A = duct connection, B = air diffuser connection.

Explanation of step model:

- One step = A dimensional change between A and B, e.g. A = Ø160 mm and B = Ø200 mm.
- Two steps = Two-dimensional changes between A and B, e.g. A = Ø160 mm and B = Ø250 mm.

COLIBRI Ceiling VF 250-600 + ALS 160-250

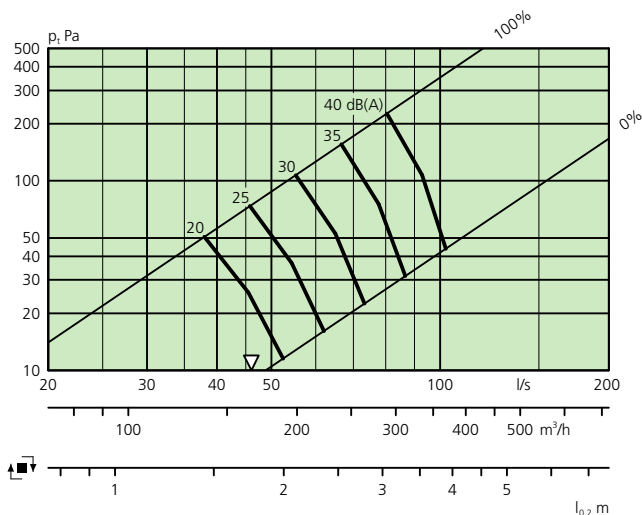

COLIBRI Ceiling VF 250-600 + ALS 200-250

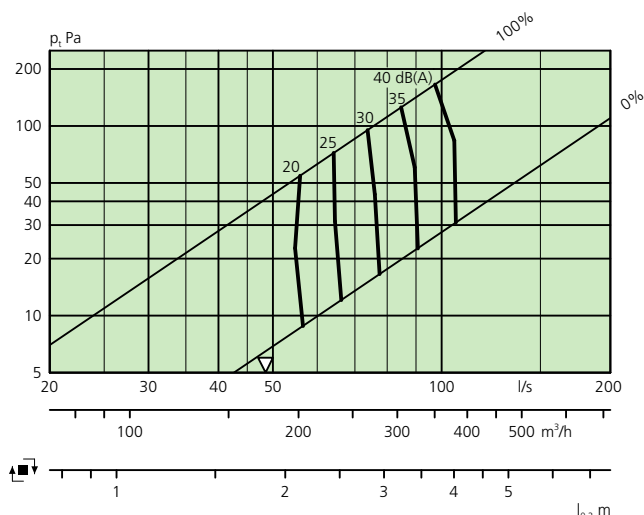

COLIBRI Ceiling VF 315-600 + ALS 200-315

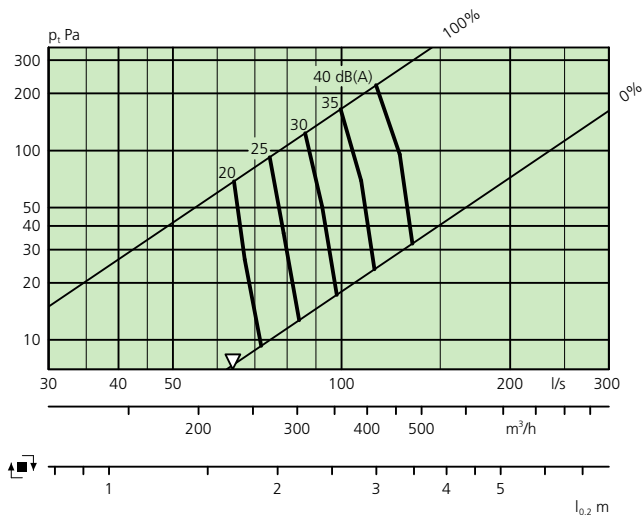

COLIBRI Ceiling VF 315-600 + ALS 250-315

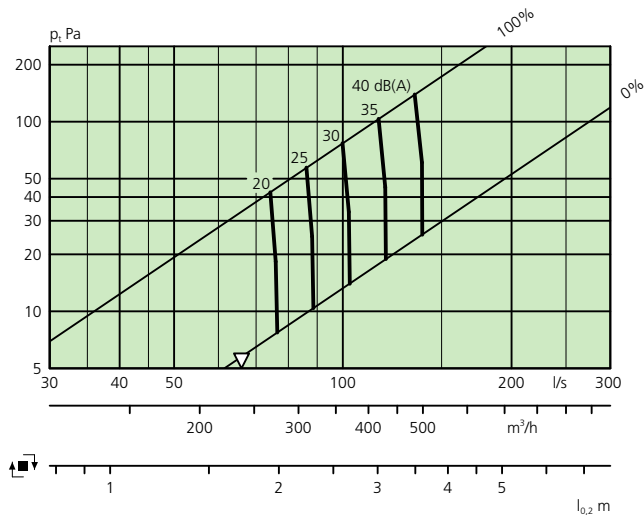

Dimensions and weights

COLIBRI Ceiling VF

Size	Dimensions (mm)				Weight (kg)	Number of nozzles
	A	Ød1	I	M		
250-600	595	249	575	70	3.5	90
315-600	595	314	575	50	3.5	130

Dimensions of opening in ceiling l x l

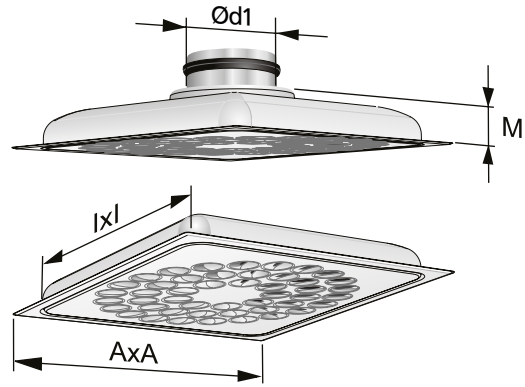

Figure 4. COLIBRI Ceiling VF.

COLIBRI Ceiling VF with REACT ALS active commissioning box

Size	Dimensions (mm)											Weight (kg)
	A	B	C	ØD	Ød	E1	F1	G1	H	K	Q	
250-600	595	504	332	159	250	314	113	214	450	100	40	8.4
315-600	595	622	388	249	315	395	95	247	575	140	40	11.3

COLIBRI Ceiling VF with ALS commissioning box – One step

Size	Dimensions (mm)											Weight (kg)
	A	B	C	ØD	Ød	E1	F1	G1	H	K	Q	
250-600	595	504	332	199	250	354	113	225	465	115	40	8.7
315-600	595	622	388	249	315	395	93	230	575	140	40	11.8

COLIBRI Ceiling VF with ALS commissioning box – Two steps

Size	Dimensions (mm)											Weight (kg)
	A	B	C	ØD	Ød	E1	F1	G1	H	K	Q	
250-600	595	504	332	159	250	314	113	205	450	100	40	7.0
315-600	595	622	388	200	315	334	93	205	550	100	40	8.7

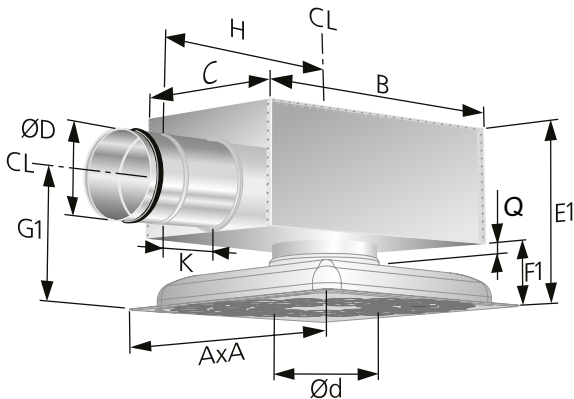

Figure 5. COLIBRI Ceiling VF with REACT ALS or ALS commissioning box.
CL = Centreline.

Frame - SAR K

Size	L	Weight (kg)
600	595	1.0

When installing size 315-600 diffusers, position the ALS box so that its branch extends 20 mm below the ceiling surface

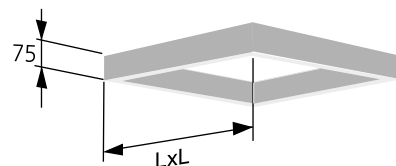

Figure 6. Frame, SAR K.

Nozzle pattern and nozzle settings

Standard and optional nozzle settings for various air distribution patterns. Note the air flow direction in the figures.



Example, nozzle pattern:

**Clock-wise swirl
(standard)**

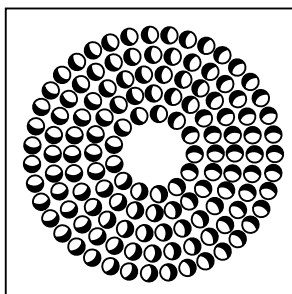

1-way

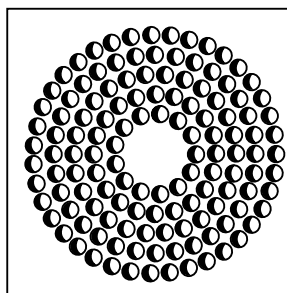

2-way

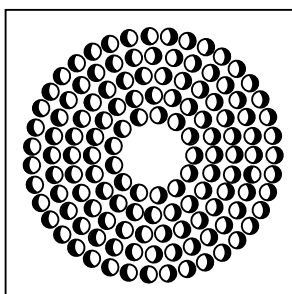

3-way

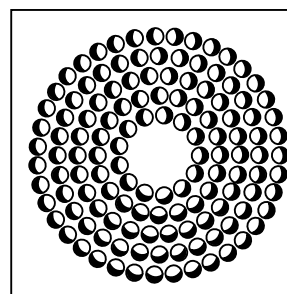

4-way

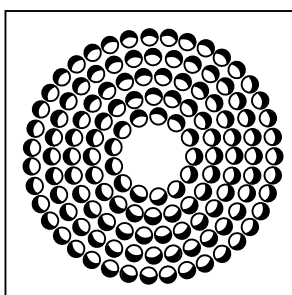

Counter-flow distribution pattern

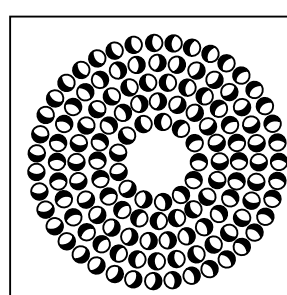

VD Vertical, diffused

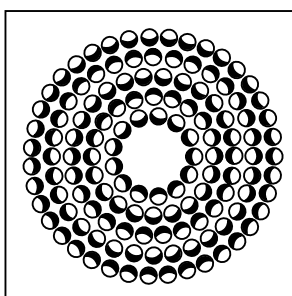

VK Vertical, concentrated

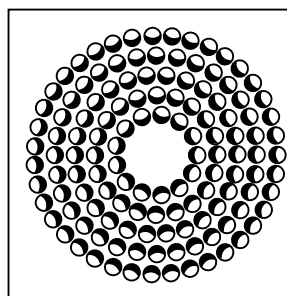

Specification

Product

Square ceiling diffuser for supply air with variable flow COLIBRI CC VF a aaa -bbb

Version:

Nom. connection dimension, mm:
250, 315

Nom. square dimension, mm: 600

Size – Standard range: 250-600
315-600

Accessories

Commissioning box with variable flow regulation REACT ALS a aaa-bbb

Version:

For COLIBRI Ceiling VF	REACT ALS
250-600	160-250
315-600	250-315

Commissioning box ALS d aaa-bbb

Version:

For COLIBRI Ceiling VF	ALS
250-600	160-250 and 200-250
315-600	200-315 and 250-315

Frame SAR b K aaa

Version

Square = K

For size:	250-600	600
	315-600	600

ADAPTER for modular suspended ceiling ADAPTER
See specification in separate product sheet

Specification text

Swegon's complete square ceiling diffuser type COLIBRI Ceiling VF with circular nozzle pattern and REACT ALS or ALS commissioning box including the following functions:

- Designed for modular suspended ceilings (600x600 mm).
- 100% flexible distribution pattern.
- Individually adjustable nozzles.
- Quick Access for rapid access to the commissioning box and the duct system.
- Cleanable REACT ALS or ALS commissioning box with removable commissioning damper.
 - Method of measurement with low systematic error.
 - Interior sound absorbing lining with reinforced surface layer.
- Powder-painted and baked white finish, RAL 9003/NCS S 0500-N.

Size: COLIBRI CC VFa aaa-bbb with REACT ALSa aaa-bbb xx pcs

Accessories

Frame: SARb K aaa xx pcs