

Catalogue

air diffusion

Linear Slot Diffusers



Model 20CSlot and Model 25CSlot



Contents

	Page
Introduction.....	Page 3
Diffuser Specification.....	Page 4
Air Patterns.....	Page 5
Flange Styles.....	Page 6
Corner Sections.....	Page 7
Selection Procedure.....	Page 8 and 9
Selection Nomograms.....	Page 10 and 11
Standard Fixing and Option Details.....	Page 12
Dimensions - Diffuser.....	Page 13
Ordering Information - Diffuser.....	Page 14
Plenum Boxes.....	Page 15
Dimensions - Plenum Boxes.....	Page 16 and 17
Ordering Information - Plenum Boxes.....	Page 18
Product Range.....	Page 19

Introduction

The Air Diffusion Model Slot is designed to combine a high air change rate capacity with maximum flexibility in air pattern and volume control, suitable for either ceiling or sidewall applications. Linear slot diffusers offer unobtrusive good looks together with functional efficiency. Linear slot diffusers are particularly suited to large open plan offices, where changing occupancy layouts demand an air distribution system that includes built in adaptability to suit the relocation of internal partitioning. Other applications include restaurants, meeting / conference rooms, atriums etc.

Available in two slot widths; a 20mm wide or 25mm wide and from 1 to 8 slot sizes offers the widest range of variations to provide the designer with performance for higher airflows when required.

SLOT20 and SLOT25 are both suitable for use in either Ceiling or Sidewall applications; the internal vanes are adjustable to provide either a horizontal or vertical air pattern discharge.

The standard flange border is 25mm but a multitude of different flange types are also available to allow the slot diffuser to be fully integrated with the ceiling design.

Purpose designed and correctly selected co-ordinating sheet metal plenum boxes may also be provided to ensure the overall performance and characteristics of the diffuser are maintained. For uniform air distribution it is recommended that plenum boxes are fitted with an equalising grid.



Specification Diffuser

Material

Extruded aluminium, architectural anodising quality complying with BS EN 755-92001 6063T6

Finishes Standard

Matt white RAL 9010 30% gloss frame with black aluminium blades.

Optional Frame Finishes

Anodised finish and other colours available to special order.

Blades

Standard black blades.
White blades optional.



End Flanges Single Units

Supplied fitted both ends, standard mechanical fixing with welded option.

Linear Runs

Supplied fitted one end only for both end units and make-up pieces without ends.

Fixing Standard

Sliding fit alignment strips, Type SP1 are supplied as standard with all linear diffuser modules for continuous appearance.

Optional

'U' bracket fixing to hemmed plenum F6 / flat foot for plaster ceilings without plenums.

Size Width

1 - 8 slots in 20mm or 25mm spacing.
Larger to special order if required.

Length

Standard lengths up to 2400mm nominal opening size.

Linear runs will be supplied, as standard, in 2400mm long sections with end flanges as necessary. The exact length of the run will be made up with intermediate make-up sections.



Where exact lengths are difficult to ascertain, we recommend that make-up sections include 200mm of solid mullion at one end for site trimming.
e.g. 1000mm make-up section cut at 1100mm with 200mm solid mullion.

Option

Linear run made up of equal sections.

Blanking Plates Light baffles* / Air Handling Light Baffles

(if specified) Supplied loose for cutting and fitting on site in sections.

*Air handling light baffle.

Extract Applications

Unless specially requested otherwise, diffusers for use in extract mode will be supplied with pattern control blades fitted to match the appearance of supply units.

Mitred Corners

These are provided as 90° composite sections (refer to tables).

Special Order

Other angles can be supplied, a template or drawing will be required. This should always be as viewed from above.

Ordering

Diffusers should be ordered by the length of the opening into which they are fitted (nominal length). Specify slot 20 or slot 25. Alternatively specify overall flange dimensions.

Please refer to ordering information.



Air Patterns

Single direction supply

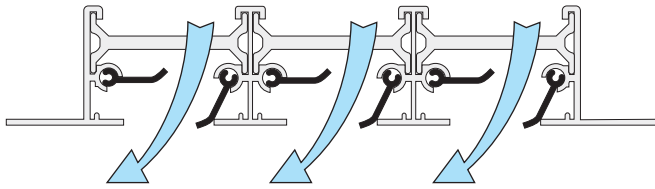

Multidirectional supply

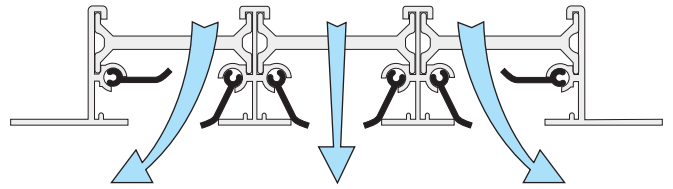

Single direction with extract

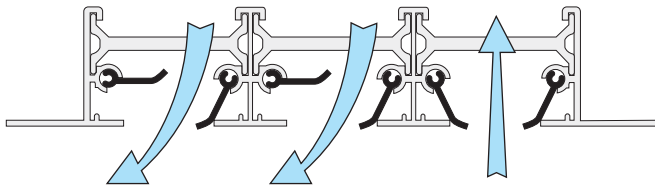

Extract

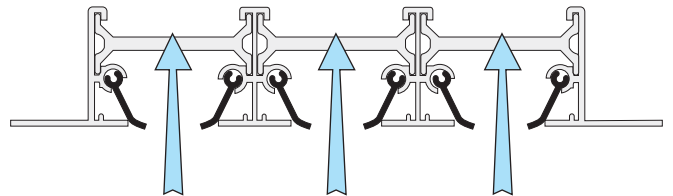

Supply with ceiling effect

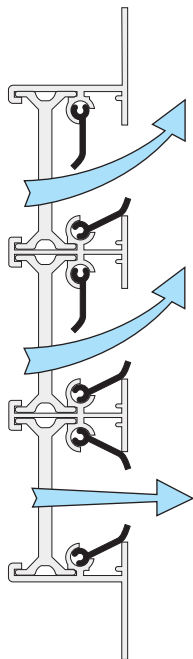

Extract

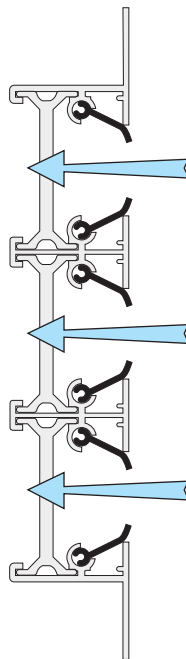

Supply free space

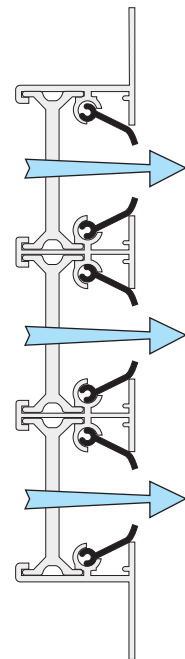

Flange Styles

All dimensions are shown in mm

25mm and 32 Frame Type

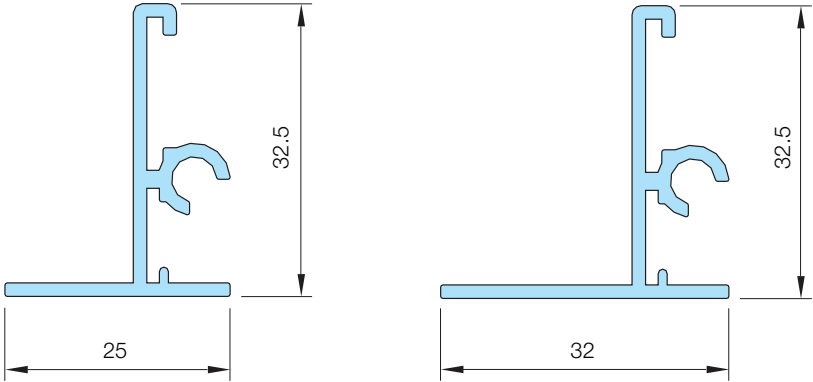

Examples of Special Frames available on request

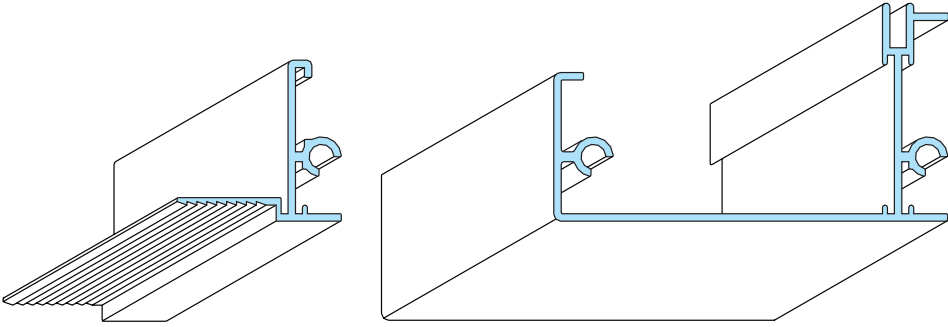
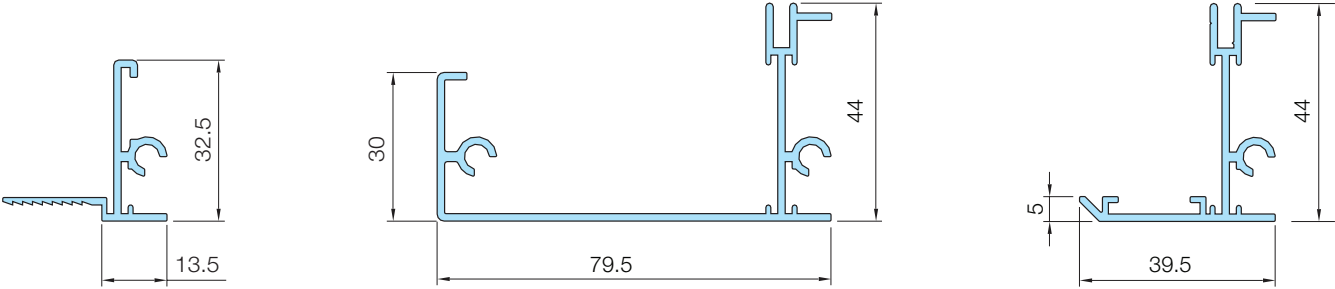

13P Plaster Type

Wide Plank Type

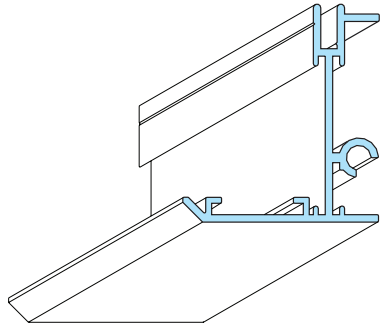

Beveledge Type



Slot Diffuser to coordinate with ceiling, having extra wide outer flange. (4 Slot 20mm shown).

Corner Sections

All dimensions are shown in mm

90° Mitred corner

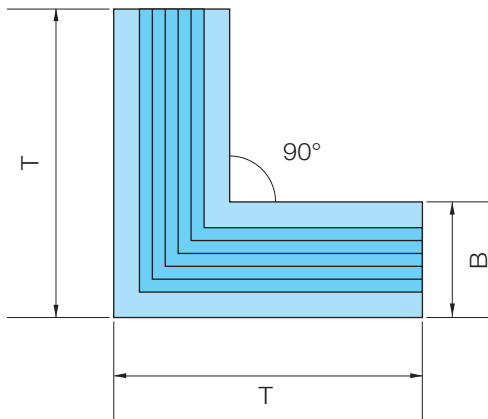

Multidirectional supply

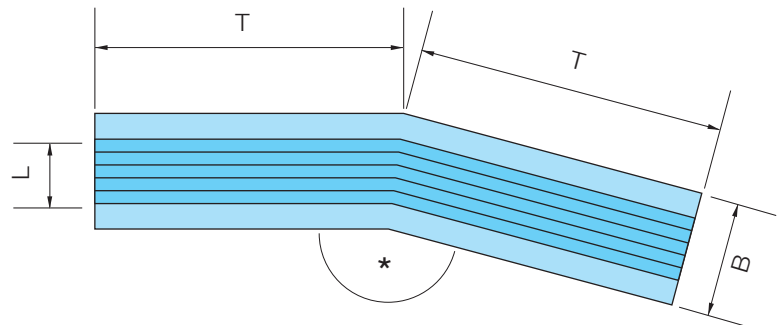

- * = Specify Angle
- B = Overall width
- T = Overall length
- L = No. of slots

25C Slot 20

No. of Slots	T	B
1	200	70
2	200	110
3	300	150
4	300	190
5	400	230
6	400	270
7	600	310
8	600	350

25C Slot 25

No. of Slots	T	B
1	200	75
2	200	120
3	300	165
4	300	210
5	400	255
6	400	300
7	600	345
8	600	390

32C Slot 20

No. of Slots	T	B
1	200	84
2	200	124
3	300	164
4	300	204
5	400	244
6	400	284
7	600	324
8	600	364

32C Slot 25

No. of Slots	T	B
1	200	89
2	200	134
3	300	179
4	300	224
5	400	269
6	400	314
7	600	359
8	600	404



Linear Slot Diffusers Selection Procedure

Data

1. Horizontal projection with ceiling effect nomogram readings are based on 10 °C cooling application. Use this nomogram for horizontal projection ceiling mounted diffusers or horizontal projection wall mounted diffusers with ceiling effect.

2. Vertical/sidewall projection nomogram readings are based on Isothermal conditions in free space without wall effect. For supply/room temperature differential for vertical throw applications from ceiling see 'Vertical Throw Multipliers for Differential Temperatures' table.

3. Use vertical/sidewall projection nomogram readings for sidewall supply application in free space. Please note that throw values apply to Isothermal conditions only and technical advice should be sought before using this method of supply for heating or cooling.

4. Nomograms are based on 1.0 metre active slot lengths. For other active slot lengths see correction table.

5. Pressure drop and sound power level readings obtained from nomograms are for slot diffusers only.

6. For pressure drop additions and sound ratings for plenum boxes see separate table.

7. When using slot diffuser in extract applications select performance using vertical/sidewall projection nomogram and ignore throw values.

8. Sound values given for plenum boxes are approximate only and dependent on spigot entry conditions. Where sound requirements are critical acoustic lining of plenum boxes should be considered. Any space requirement to accommodate lining material must be added to selected box size.

Selection Procedure

The method set out below used in conjunction with the tabulated data allows slot 20 and 25 linear diffusers to be selected for supply or extract modes in either ceiling or sidewall applications.

Air pattern is determined by the position of the pattern control blades as illustrated on page 3.

Method – Slot Diffuser

1. Establish volume flow rate per metre by dividing total air volume by the active slot length to give litres/metre.

2. Using appropriate nomogram place a straight edge through the volume as calculated and position to pass through required throw value with satisfactory noise and pressure readings. Select suitable slot width and number of slots where straight edge passes through slot selection line. Finally realign straight edge through volume and slot selected points and read exact throw, sound and pressure figures.

3. Readings obtained from the above using horizontal ceiling nomogram are based on 1 metre active slot length. (See note on nomogram). For other active lengths see 'Active Length Correction Table' for throw multiplier and sound level adjustment.

4. Readings obtained from the methods above using vertical/sidewall projection nomogram are based on Isothermal conditions. For vertical throw values for temperature differential see 'Vertical Throw Multipliers for Differential Temperatures' correction table to obtain throw multiplier for varying number of slots.

Method – Plenum Boxes

1. Determined volume of plenum box by multiply chosen length of box x volume/metre of slot. (A maximum box size of 2.0m long is recommended). Plenum boxes in excess of 1500mm long require 2 or more inlet spigots.

2. Select plenum spigot size from table on page 9. Maximum entry velocity of 3.5 m/sec is recommended. Velocities in excess of this may lead to noise generation.

3. From table of 'Plenum Box Pressure Drops and Sound Ratings' read off additional pressure drop to be added to slot diffuser pressure drop from

nomogram. Ensure that plenum box sound power level is not more than slot diffuser reading if latter is design criteria.

4. Where it is not possible to accommodate standard plenum boxes, special configurations are available, but should always maintain an equivalent cross-sectional area to a standard box. Consideration should also be given to the inlet spigot in respect of positioning, sizing and inlet velocities. Consult our technical department for detailed advice

Commissioning

Calculation

Volume $9m^3/s$ =

Av. measured velocity (m/s) x
active length (m) x
number of slots x
flow factor.

The flow factor is simply the width of the slot in metres at the point where the velocity is measured.

Maximum flow factors

Slot 20		Slot 25	
Hor.	Ver.	Hor.	Ver.
0.009	0.011	0.011	0.011

It should be noted that throw figures given apply to maximum blade openings in the configurations listed. If blade opening size as measured (in metres) should be substituted.

Velocity measurement

To measure the velocity it is important that an instrument with a measuring head small enough to fit the blade opening is used. The most suitable instrument is a hot wire anemometer. Take velocity readings at the blade openings at a maximum of 150mm centres along the active length to obtain an accurate average velocity and use this value in the formula above.

Exhaust

Procedure same as supply but with the anemometer probe reversed.

Linear Slot Diffusers

Selection Procedure

Example

An 8.0 metres long ceiling mounted horizontal throw slot diffuser is required to deliver a total volume of 600 L/sec with a maximum throw of 6.1 metres to a terminal velocity of 0.50 m/s. The active length of diffuser is 6.0 metres supplied from:-

4 - 1500mm long supply plenums.

$$\text{Active slot volume rate} = \frac{600}{6} = 100 \text{ L/s/m}$$

Active slot lengths are 1500mm and from 'Active length Correction Table', a multiplier of 1.15 must be applied.

Nomogram throw x 1.15 = Required throw.

$$\text{Therefore: } \frac{\text{Required throw}}{1.15} = \frac{6.1\text{m}}{1.15} = 5.3\text{m}$$

for nomogram selection.

From nomogram using volume of 100 L/s/m and throw of 5.3m select 3 slot 20 diffuser with NR sound power level of 27 and total pressure drop of 17 Nm². From 'Active Length Correction Table', obtain a sound power level correction of + 2 NR giving a total of 29 NR.

$$\text{Volume for each plenum box} = \frac{600}{4} = 150 \text{ L/s.}$$

From Plenum Box Spigot Sizing table opposite select spigot size relative to chosen inlet velocity. At 3.0 m/s we obtain a spigot size of 275mm diameter and referring to 'Plenum Box Pressure Drops and Sound Ratings' opposite, we can see that the plenum pressure drop is 8.0 Pa with a sound rating NR of 30.

As sound power level reading is in excess of nomogram reading of 29 NR use latter figure. If 29 NR is maximum critical design criteria increase spigot size to 300 diameter at 2.5 m/s and NR 25.

Total pressure drop for slot diffuser and plenum box = 17 Pa + 8 Pa = 25 Pa.

Plenum box drops and sound ratings

	Spigot velocity m/s					
	1.5	2.0	2.5	3.0	3.5	4.0
Pressure drop Pa*	2	4	6	8	12	16
Sound power level N*			25	30	35	40

*approximate - dependent upon entry conditions.

Pressure drops additional to slot diffuser.

Sound power level - use higher of slot or plenum value.

Vertical throw multipliers for differential temperatures

No. of slots	Temperature differential ambient / supply (°C)						
	-15	-10	-5	0	+5	+10	+15
1	1.54	1.33	1.15	1.0	0.87	0.75	0.65
2	2.0	1.59	1.26	1.0	0.79	0.63	0.50
3	2.46	1.88	1.37	1.0	0.75	0.53	0.41
4-8	2.71	1.95	1.4	1.0	0.71	0.51	0.37

Plenum box spigot volumes (l/s)

Diameter mm	Spigot velocity m/s					
	1.5	2.0	2.5	3.0	3.5	4.0
100	10	15	19	22	26	30
125	18	24	30	35	41	47
150	25	34	42	51	60	68
175	35	46	58	70	82	94
200	45	60	75	91	109	121
225	58	77	96	117	137	151
250	71	95	120	142	170	191
275	86	115	145	172	205	230
300	103	139	172	208	240	275
325	120	160	200	240	280	320
350	140	188	235	280	328	375
400	185	245	310	370	430	495

Linear Slot Diffusers Selection Nomogram

Horizontal Projection with Ceiling Effect

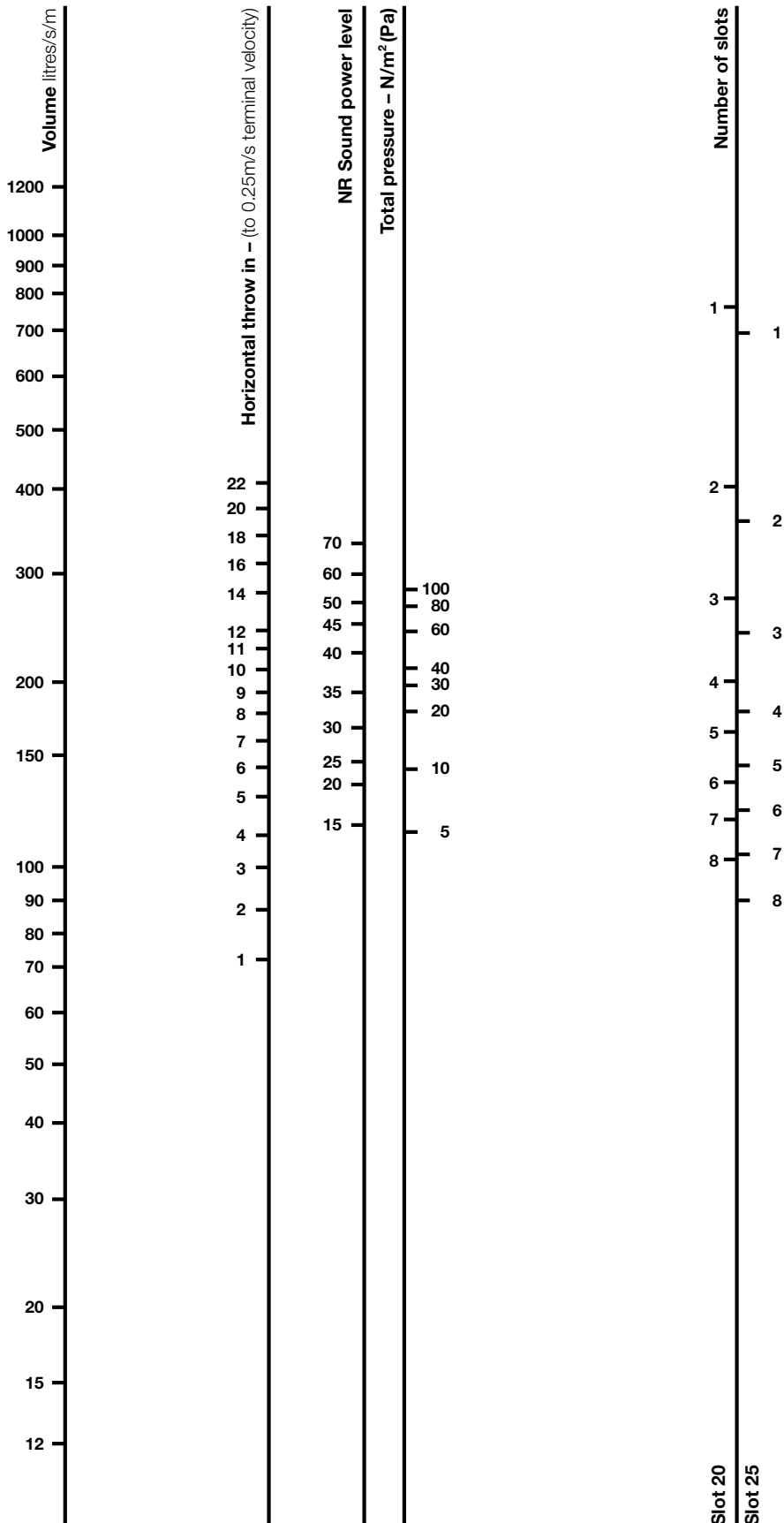

Active length correction table

Diffuser Active length (m)	throw multiplier	Sound level correction
0.4	0.6	-4 db
0.5	0.7	-3 db
1.0	1.0	0
1.5	1.15	-2 db
2.0	1.25	-3 db
3.0+	1.30	-5 db

Throw is based on a temperature differential of 10 °C cooling to terminal velocity of 0.25 m/s for 1 metre active length with a room height of 2.7m when mounted flush with an unobstructed flat ceiling.

For other active lengths refer to above correction table.

Throw factors are for throw in one direction by alternating throw direction at each blade length (600mm) a factor of x 0.6 can be used.

All NR ratings are based on a room absorption of 8 db.

Linear Slot Diffusers Selection Nomogram

Vertical/Sidewall projection in free space
(No Wall or Ceiling Effect)

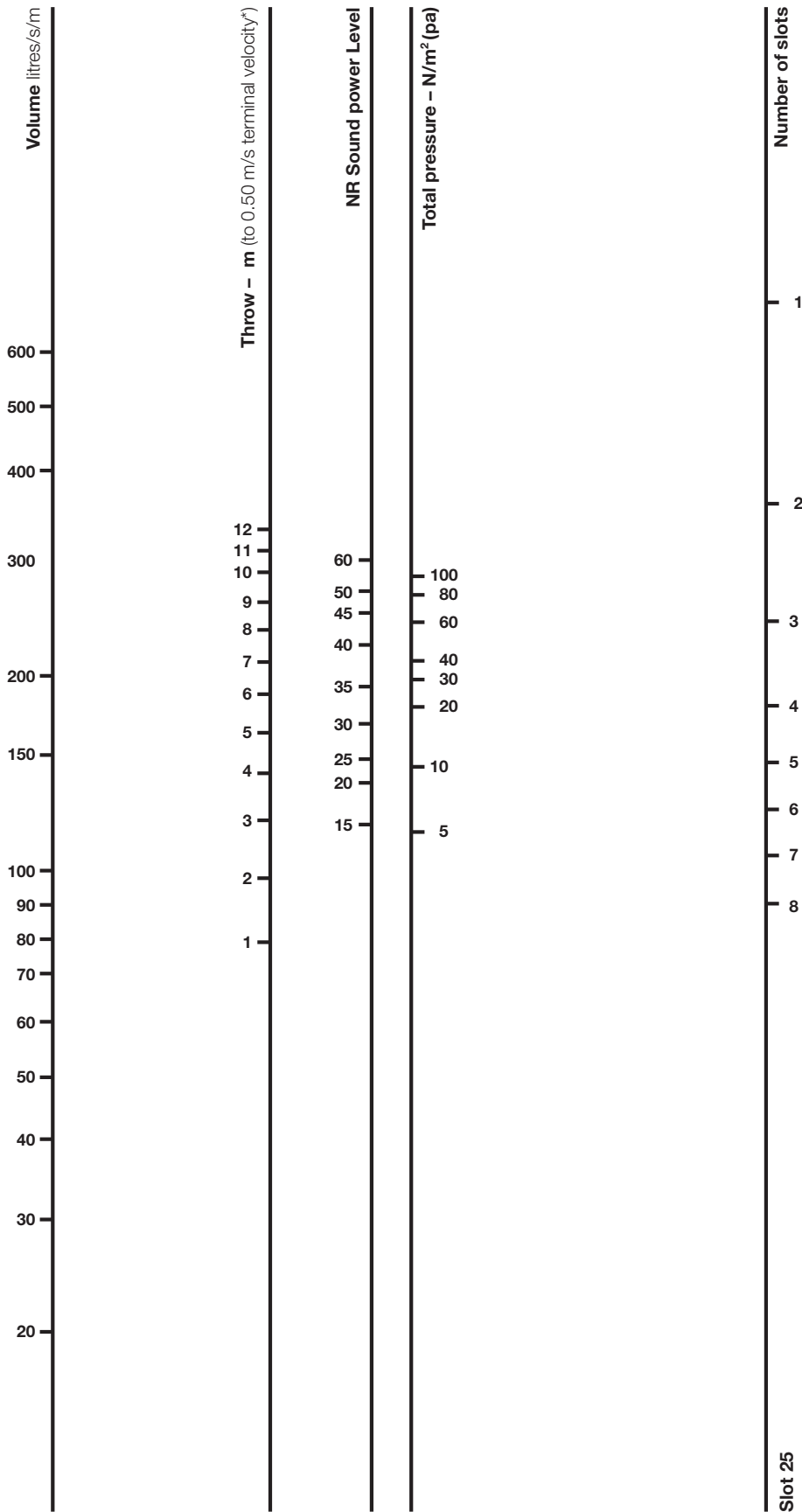

Active length correction table

Diffuser Active length (m)	throw multiplier	Sound level correction
0.4	0.6	-4 db
0.5	0.7	-3 db
1.0	1.0	0
1.5	1.15	-2 db
2.0	1.25	-3 db
3.0+	1.30	-5 db

Throw is based on a isothermal conditions to a terminal velocity of 0.50 m/s for 1 metre active lengths.

For other active lengths refer to above correction table.

For other temperature differentials for vertical projection see throw multiplier correction tables.

Throw factors are for throw in one direction by alternating throw direction at each blade length (600mm) a factor of x 0.6 can be used.

All NR ratings are based on a room absorption of 8 db.

Standard Fixing and Option Details

All dimensions are shown in mm

F6 (Plaster Fix) Using 32mm Flange

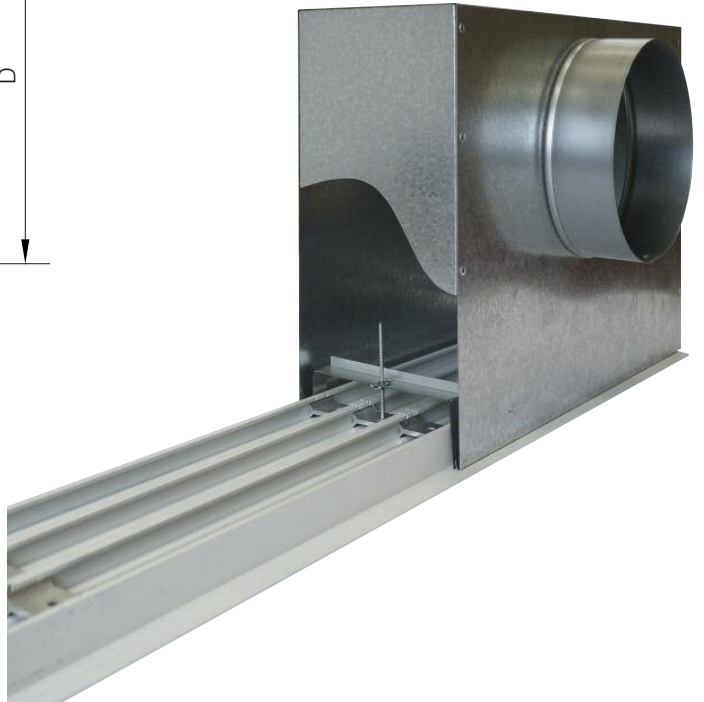
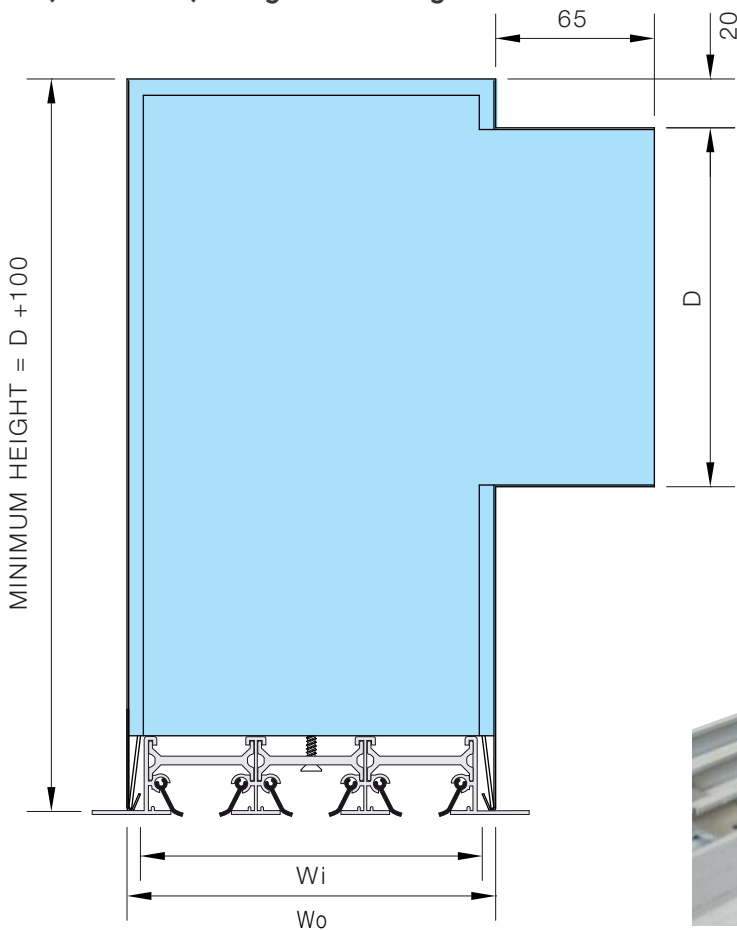

Blanking Plate using 32mm Flange

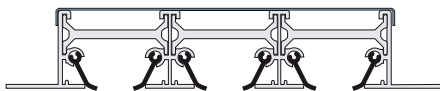

Note: Blanking Plate shown only

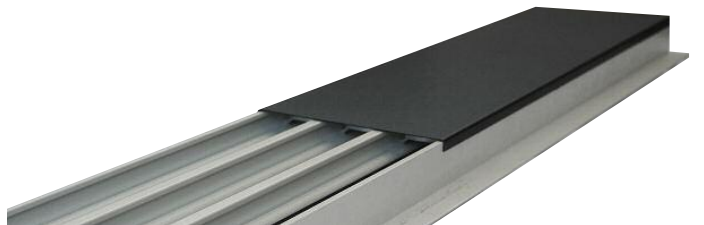

Air Handling Light Baffle using 32mm Flange

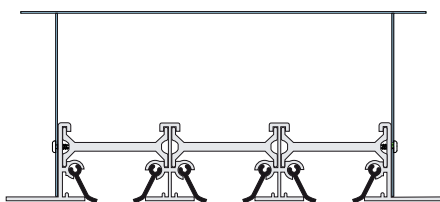

Note: Light Baffle shown only



Dim Description	Number of Slots															
	1		2		3		4		5		6		7		8	
Wo Overall width hemmed box	56	61	96	106	136	151	176	196	216	241	256	286	296	331	336	376
Wi Clear inside hemmed box	48	53	88	98	128	143	168	188	208	233	248	278	288	323	328	368
Wf Clear internal size-fork fixing	40	45	80	90	120	135	160	180	200	225	240	270	280	315	320	360

Dimensions and Details

All dimensions are shown in mm

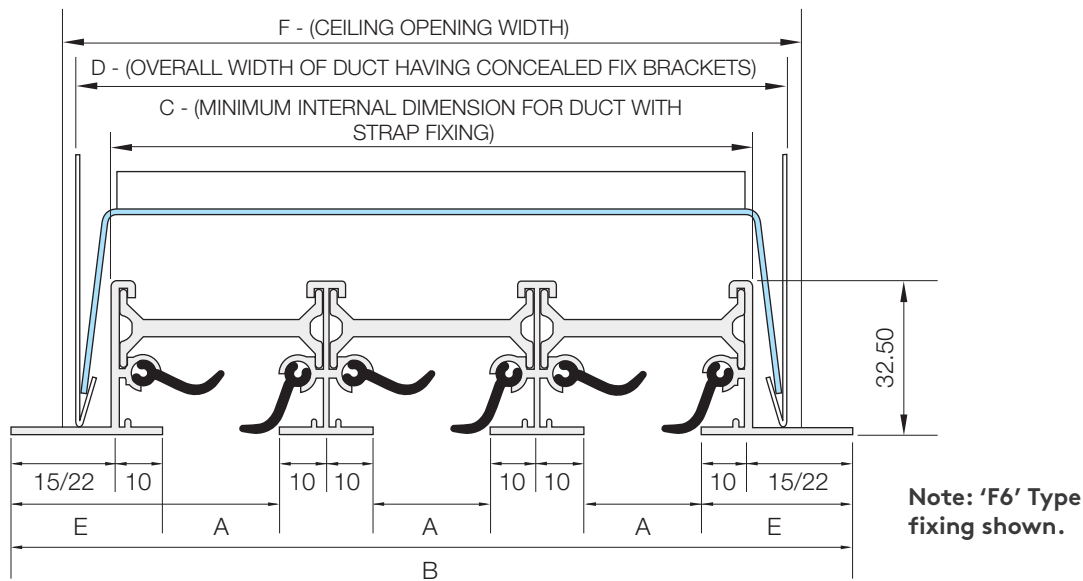

25C Slot 20

No. of Slots	A	B	C	D	E	F
1	20	70	43	56	25	60
2	20	110	83	96	25	100
3	20	150	123	136	25	140
4	20	190	163	176	25	180
5	20	230	203	216	25	220
6	20	270	243	256	25	260
7	20	310	283	296	25	300
8	20	350	323	336	25	340

25C Slot 25

No. of Slots	A	B	C	D	E	F
1	25	75	48	61	25	65
2	25	120	93	106	25	110
3	25	165	138	151	25	155
4	25	210	183	196	25	200
5	25	255	228	241	25	245
6	25	300	273	286	25	290
7	25	345	328	331	25	335
8	25	390	363	376	25	380

32C Slot 20

No. of Slots	A	B	C	D	E	F
1	20	84	43	56	32	60
2	20	124	83	96	32	100
3	20	164	123	136	32	140
4	20	204	163	176	32	180
5	20	244	203	216	32	220
6	20	284	243	256	32	260
7	20	324	283	296	32	300
8	20	364	323	336	32	340

32C Slot 25

No. of Slots	A	B	C	D	E	F
1	25	89	48	61	32	65
2	25	134	93	106	32	110
3	25	179	136	151	32	155
4	25	224	183	196	32	200
5	25	269	228	241	32	245
6	25	314	273	286	32	290
7	25	359	328	331	32	335
8	25	404	363	376	32	380

25C Type slot run

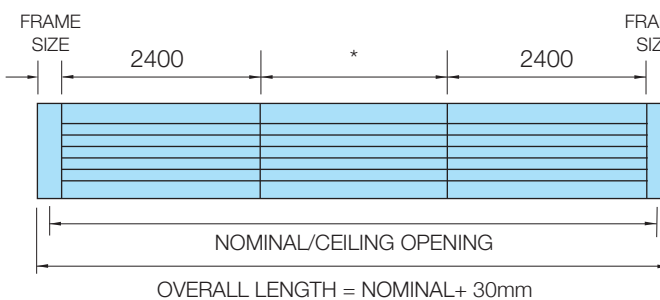

* Make up pieces manufactured to suit
Maximum single section slot length = 2400mm

32C Type slot run

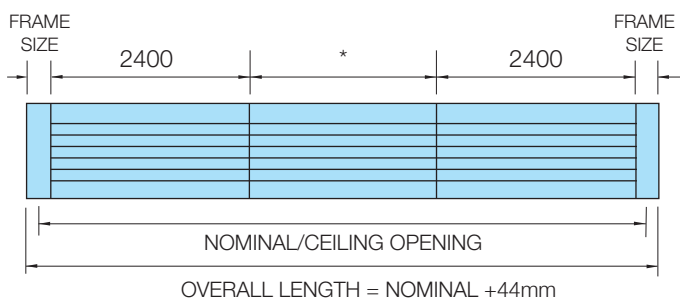

* Make up pieces manufactured to suit

Ordering Information Slot Diffuser

Example

Frame	Slot	No. of Slots	Slot Width	End Flanges	Fix	Frame Finish	Blade Finish
25C	Slot	4	25	E1	F6	3	4
		1		E0 Open end		3 White RAL 9010 30% gloss matt	
		2		E1 End border one end			
		3		E2 End border two ends		6 Other finish / colours available to special order	
		4		EP1 End plate one end			
		5		EP2 End plate two ends			
		6					
		7					
		8					
25C	25mm, flat surface flange		20		F6 'U' Bracket plenum fixing and plaster ceiling flat foot option	3 - White	
32C	32mm, flat surface flange (suitable for plaster ceiling)		25		SP Special fixing	4 - Black/white (Aluminium blade)	
13P	Plaster frame					6 - Other colours available to special order	
79WP	Plank type						
39B	Beveled type						

The model described in the example above would be : 25C - Slot 4 - 25 - E1 - F6 - 3 - 4

Important: please allow for any lighting zones when selecting plenum boxes

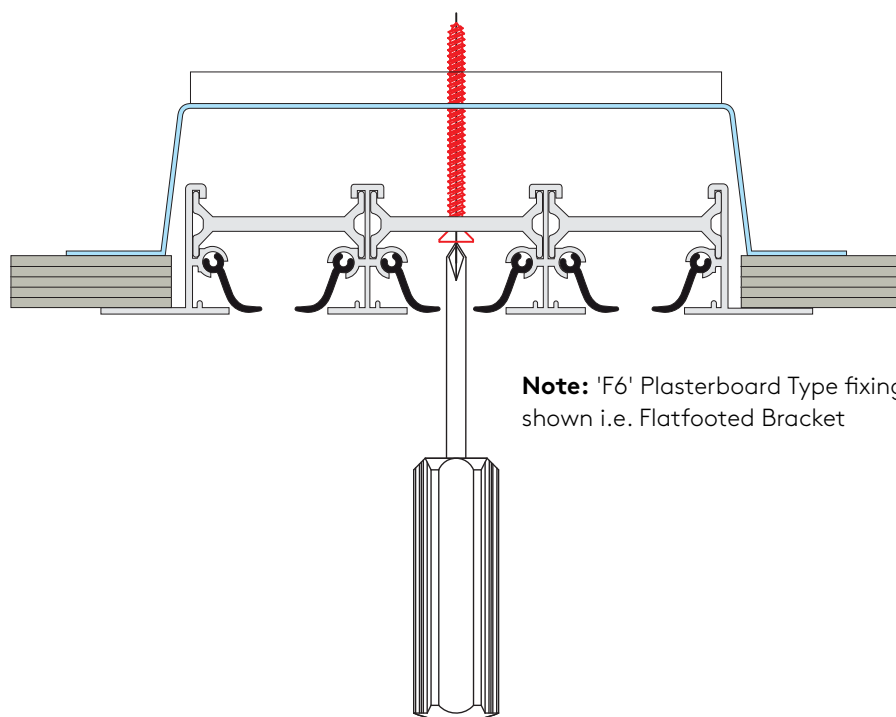

Note: 'F6' Plasterboard Type fixing shown i.e. Flatfooted Bracket

Important Note: All orders must be addressed to Swegon Air Management Ltd.

Plenum Boxes

Plenum Boxes

Supplied unlined as standard with side entry spigot.

Plenum boxes can be supplied internally lined with 6mm class "O" foam at extra cost. Apply to sales office for price.

Specifications

Material

Standard is a nominal 0.7mm thick galvanised or zinc coated steel.

Construction

Plenum boxes are generally fabricated in 3 sections having tray ends, which are either mechanically joined or spot welded to form an airtight seal. Flush ends (no tray indents) are also available. As standard, spigots are side entry and located centrally. All boxes are supplied with plain edges, as standard, (F0 fixing).

Standard Installation Method

The tray ends of the plenum box incorporate a 15mm indent, on each side to allow for 8mm drop rod fixings, which gives space for holes to be drilled (by others) without disturbing the active section.

Installation Options

Fixing lugs can be factory fitted if

preferred or special fixing methods (by others) may be used.

For plenum boxes having flush ends separate hanging brackets/fixing lugs need to be fitted to allow independent support of diffuser and plenum box.

Accessories

Joggled style plenum boxes or pan adapters.

Spigot dampers include cord operated and manual quadrant.

6mm thick acoustic lining Class 'O' fire rating (Standard).

Equalising grids (50% free area perforated mesh).

Fixing lugs or special fixings (by others).

Flush ends or indented ends.

Finish

Self finish galvanised or zinc coated steel as standard.

Optional specialists finishes available.

Pressure Drops and Sound Rating

The pressure drop given is for supply grille with damper fully open. When the grille is installed with plenum box, the pressure loss of the box has to be added to the grille.

	Spigot Velocity m/s					
	1.5	2.0	2.5	3.0	3.5	4.0
Pressure Drop Pa*	2	4	6	8	12	16
Sound Power Level NR*	-	-	25	30	35	40

* The figures given are approximate - dependent upon spigot entry conditions

Plenum Box Spigot Volumes (l/s)

Diameter (mm)	Spigot Velocity m/s					
	1.5	2.0	2.5	3.0	3.5	4.0
100	10	15	19	22	26	30
125	18	24	30	35	41	47
150	25	34	42	51	60	68
175	35	46	58	70	82	94
200	45	60	75	91	109	121
225	58	77	96	117	137	151
250	71	95	120	142	170	191
275	86	115	145	172	205	230
300	103	139	172	208	240	275
325	120	160	200	240	280	320
350	140	188	235	280	328	375
400	185	245	310	370	430	495

Plenum Box Dimensions

All dimensions are shown in mm

Type PBL-1

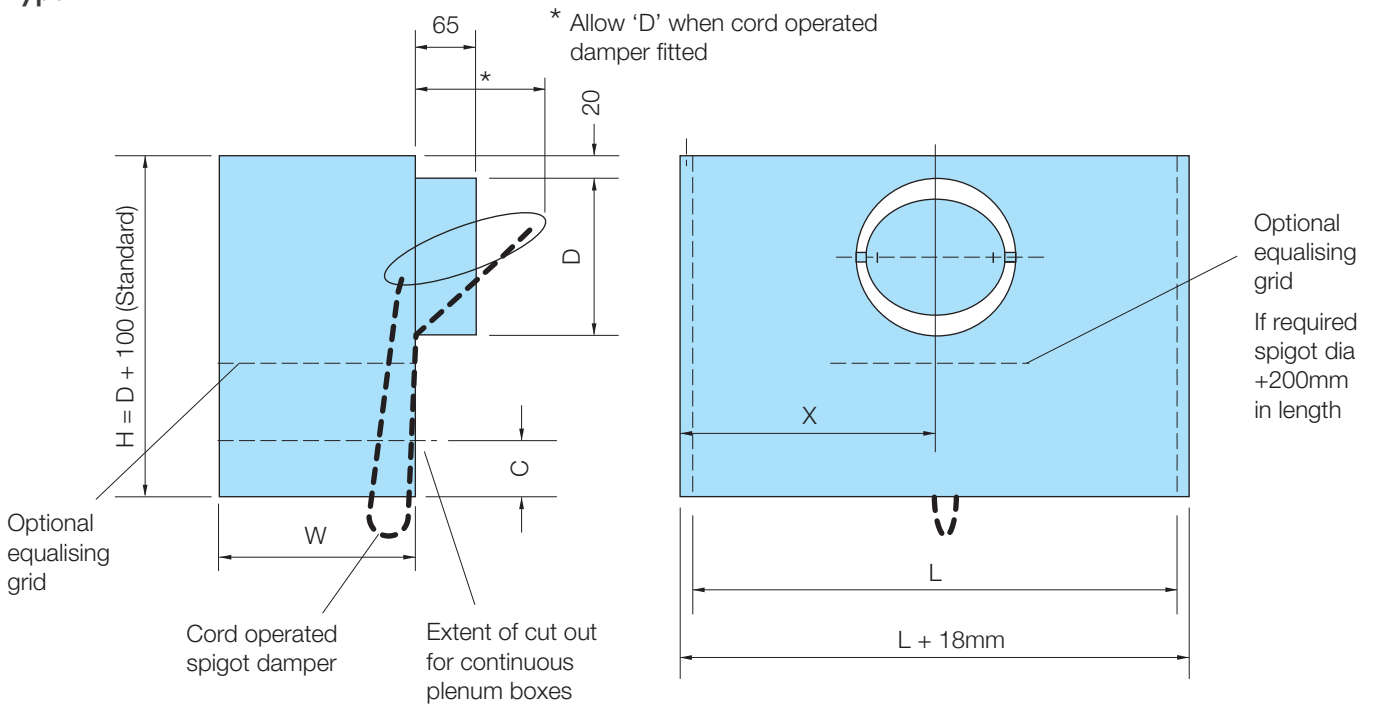

Order Detail

H	L	W	D	C		
				LH	RH	X
-	-	-	-	-	-	-

Angle Bracket fixing available if required.

Type PBL-1 for F6 fixing

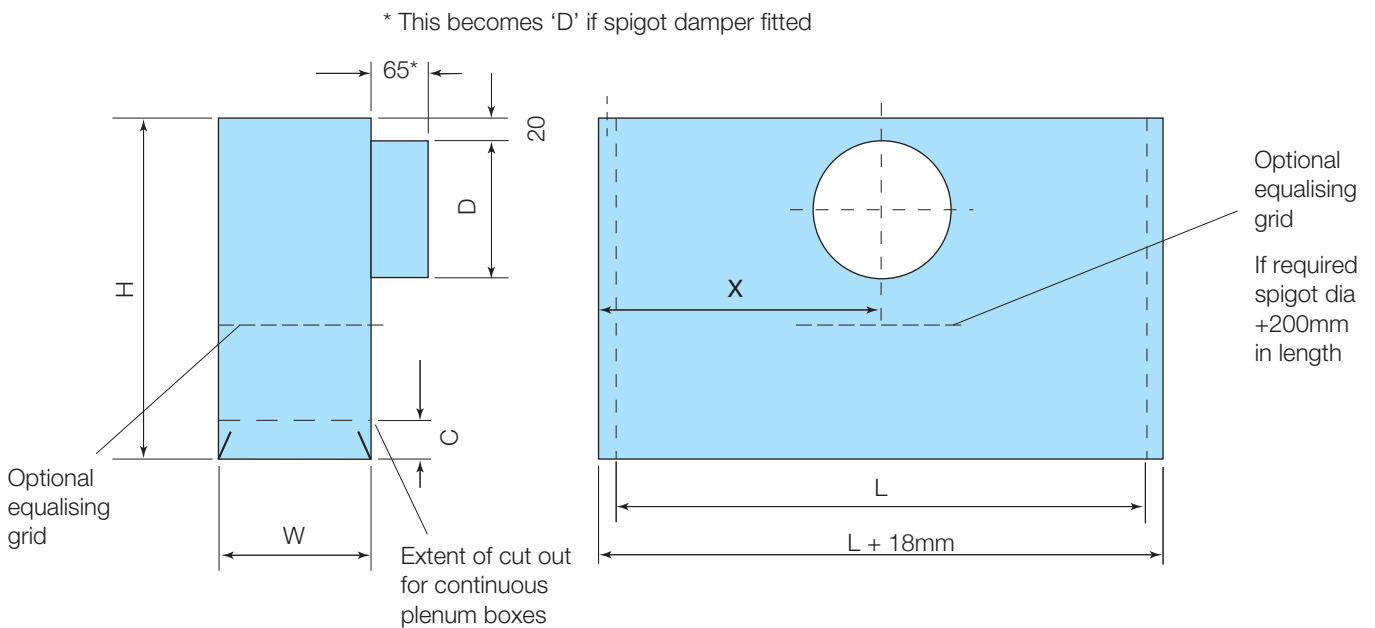

Order Detail

H	L	W	D	C		
				LH	RH	X
-	-	-	-	-	-	-

Boxes shown with Indented Ends.

Plain End boxes also available.

NB: For plenum boxes longer than 1500mm two or spigots may be required.

Other spigot options available including flat oval rectangular and specialist.

Plenum Box Dimensions Continued

Manual Quadrant Control Damper

All dimensions are shown in mm

6mm Acoustic Lining

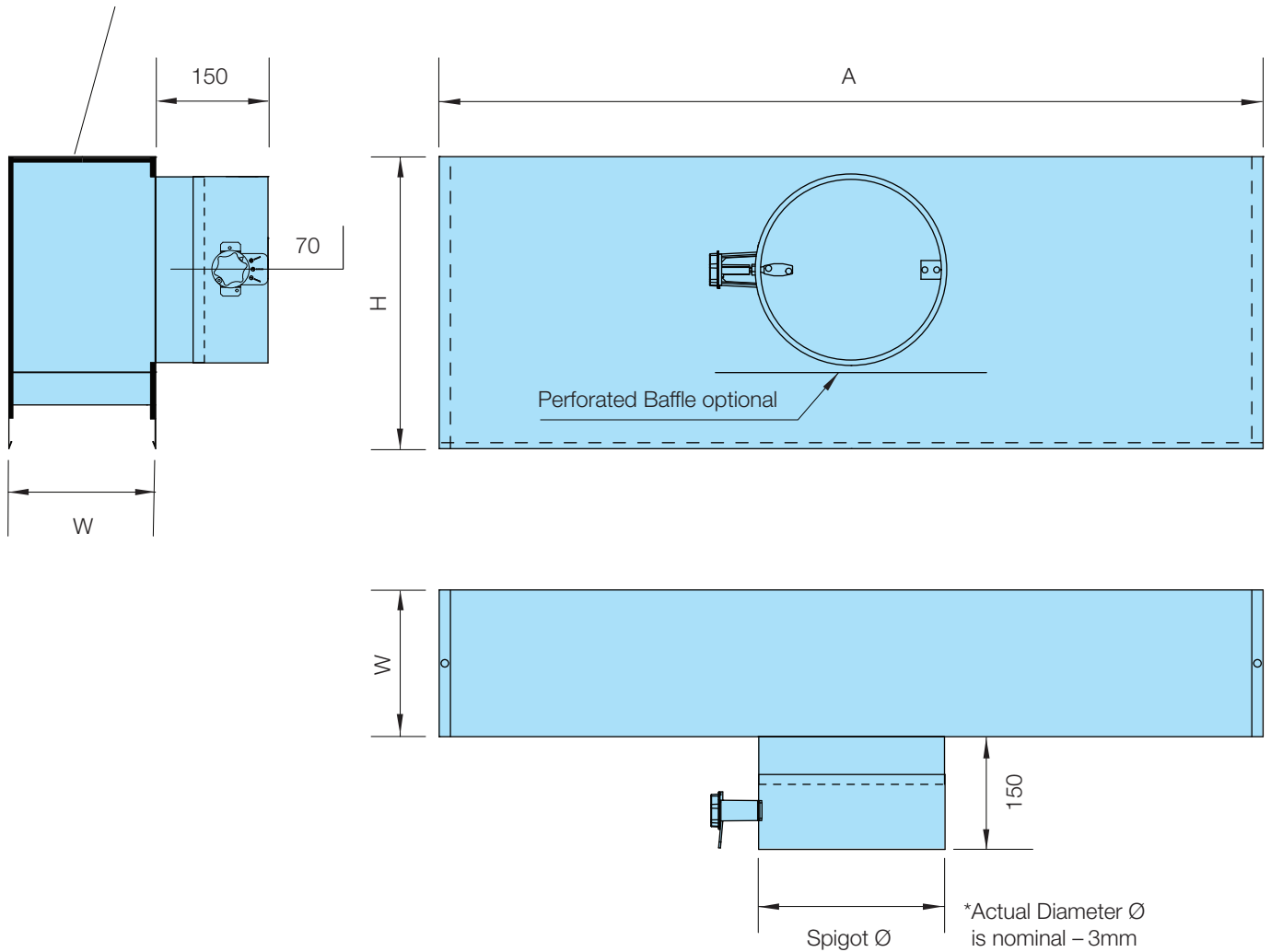

Model Ref	Nominal * Spigot Ø	Open Blade Protrusion (mm)
CB	100	-
CB	125	-
CB	150	-
CB	160	-
CB	200	-
CB	250	20.5
CB	300	45.5
CB	315	53
CB	350	70.5
CB	355	73

NB: CB is a balancing damper only and is not suitable for use as a shut off damper.

Ordering Information Plenum Boxes

Example

Model	Internal Lining	Spigot Damper	Options	Dimensions
PBL-1	U	N	0	

Plenum Boxes

PBL-1 Linear Plenum Box with either a circular or square side entry spigot

PBL-2 Linear Plenum Box having either a circular or square top entry spigot

PBL-3 Linear Plenum Box with joggle section having either a circular or square side entry spigot

U - Standard Unlined Plenum Box

L - 6mm Class 'O' Black Internal Lining. (Standard)

N - Plain spigot no damper.

Q - Quadrant damper.

C - Cord operated damper fitted to spigot.

0 - No options.

2 - Equalising grid.

3 - Fixing lugs fitted to side of plenum.

4 - Tongued ends on each end of plenum.

5 - Hemmed Edge for secret strap fixing.

See example below

Dimensions 25C - SLOT - 4 - 25, Example

Neck Size	Plenum Height	Circular Spigot Diameter	OR	Sq./Rect. Spigot Width x Height	Centre Line of Spigot
L x W 1000 x 196	H 350	∅D 250		C x E 0	X 515

'0' Denotes Standard.

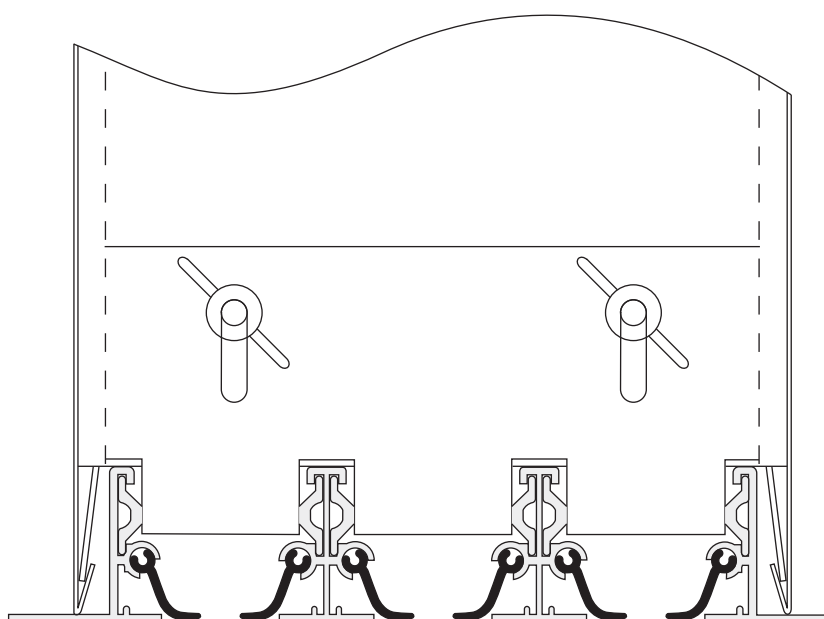

Option 4
Tongue end of plenum box.

Product Range



Flowbar High Capacity Slot Diffuser



Linear Slot Diffuser



Circular Ceiling Diffuser



Square and Rectangular Diffuser



Exhaust and Supply Air Valves



Egg Crate Grilles



Linear Narrow Blade Bar Grille



Circular Floor Swirl



Fixed Blade Grille



Linear Floor Grille



Single Deflection Grille



Perforated Face Ceiling Diffuser



Variable Air Pattern Ceiling Swirl Diffuser



Double Deflection Grille

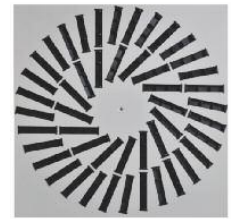

Ceiling Swirl Diffuser



Non Vision Grille



Linear Wide Blade Bar Grille



Security Grille



Fixed Blade External Louvre

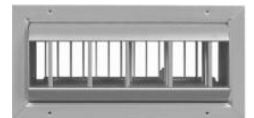

Cylinder Jet Diffuser



Displacement Ventilation Diffuser



Fixed Blade Linear Ceiling Diffuser



Jet Diffuser

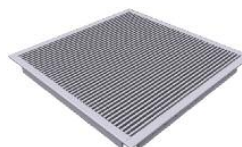

Panel Floor Grille

Note: Redesign may occur which supersedes the information in this brochure. Please refer to our website for latest information.

actionair | air diffusion | airfiltrera | airovolution | naco

Stourbridge Rd, Bridgnorth,
WV15 5BB, Shropshire, UK

Tel: +44 (0)1746 761921

Email: sales@air-diffusion.co.uk

Website: air-diffusion.co.uk

The statements made in this brochure or by our representatives in consequence of any enquiries arising out of this document are given for information purposes only. They are not intended to have any legal effect and the company is not to be regarded as bound thereby. The company will only accept obligations which are expressly negotiated for and agreed and incorporated into a written agreement made with its customers.

Due to a policy of continuous product development the specification and details contained herein are subject to alteration without prior notice.