

SWAN™ WTW

Linear slot air diffusers of wall-to-wall design for ceilings



QUICK FACTS

- Wall-to-wall installation
- Diffuser face of light aluminium design
- 2, 3 or 4 slots
- Horizontal/vertical air distribution
- Telescopic installation
- White-painted or natural anodized diffuser parts
- Black air deflectors made of ABS plastic
- Corner module, 90°
- Removable damper
- Standard colour White RAL 9003
 - 5 alternative standard colours
 - Other colours upon request

SWAN WTW Size	AIR FLOW - SOUND PRESSURE ROOM (Lp10A) *)					
	25 dB(A)		30 dB(A)		35 dB(A)	
	l/s	m ³ /h	l/s	m ³ /h	l/s	m ³ /h
2-1158-160	40	144	54	194	78	281
2-1158-200	57	205	77	277	100	360
2-1158-250	70	252	88	317	110	396
3-1158-160	41	148	60	216	89	320
3-1158-200	59	212	84	302	115	414
3-1158-250	85	306	110	396	145	522
4-1158-160	36	130	48	173	76	274
4-1158-200	60	216	82	295	115	414
4-1158-250	85	306	115	414	160	576

Data specified in the table applies to an air diffuser with SWAN T commissioning box, 1-way and 2-way air diffusion at 50 Pa total pressure.

*) L_{p10A} = Sound pressure incl. A-filter with 4 dB room attenuation and 10 m² room absorption area.

Technical Description

Version

Rectangular linear supply air diffuser with two to four air slots for wall-to-wall installation. Each slot is equipped with black air deflectors and the direction of air discharge is adjustable. Active and passive slot air diffusers are included in the delivery. On delivery, the standard setting is for 1-way diffusion for two and three air slots and 2-way diffusion for four air slots. The SWAN slot diffusers for wall-to-wall installation have a SWAN T commissioning box mounted on the active slot diffusers. The various parts are described below the headings Supply air sections and Accessories.

Supply air sections

SWAN ACT: Active air diffuser section with 2-4 slots and 1158 mm long for installation in a SWAN T commissioning box.

SWAN PASS: Passive air diffuser section with 2-4 slots and 1158 mm long (looks like the active section) with cover plate for installation between the active slot diffusers.

SWAN END: Passive end diffuser section with 2-4 slots and varying length 595-1174 mm (looks like the active section) with cover plate for installation as the start and end diffuser including the end-piece, 16mm).

Materials and finish

The SWAN is made of aluminium. The air diffuser is painted in out standard colour, with black air deflectors or it can be supplied with a natural anodized finish with black air deflectors. Black air deflectors are recommended in order to have a less visible joint between the diffusers. The air deflectors are made of ABS plastic. The standard module length is 1158 mm.

- Standard colour:
 - White semi-gloss, lustre 40, RAL 9003/NCS S 0500-N
- Alternative standard colours:
 - Silver gloss, lustre 80, RAL 9006
 - Grey aluminium gloss, lustre 80, RAL 9007
 - White semi-gloss, lustre 40, RAL 9010
 - Black semi-gloss, lustre 35, RAL 9005
 - Grey semi-gloss, lustre 30, RAL 7037
- Non-painted finish and other colours available on request.

Accessories

Commissioning box:

SWAN T: Made of galvanised sheet steel. The commissioning box contains a commissioning damper and fixed measurement tapping. The same commissioning box as standard in one-off deliveries. The box is supplied with a connection in the long side (L).

Sound absorber:

An accessory for the commissioning box, consisting of sound absorbing material with a reinforced surface layer, fire resistance rated to B-s1,d0 in accordance with EN ISO 11925-2.

Corner module:

SWAN CORN90: Used for continuous installation around a corner. The same extruded profile material is used as in SWAN slot diffuser to provide a uniform design at a standard 90° angle.

Project design

Wall to wall design is achieved by joining several 1158 mm long modules to the desired continuous length. The modules can be active or passive. In either end of the length a passive end module is placed. On the short side of the end-module an

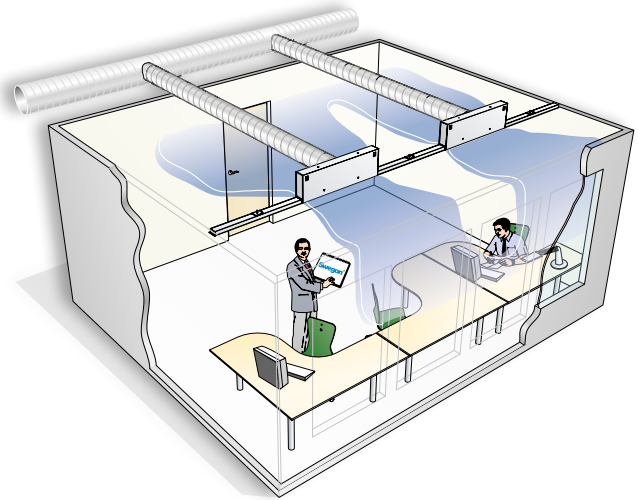

end piece is mounted. The length of the end module can be adapted to fit the desired length of the wall to wall installation. Cover plates are included on the passive slot diffusers and on the slot diffusers that are placed first and last in the installation. See Figures 1, 2 and 6a-6d.

Installation

The commissioning box should be suspended by means of threaded rods from the ceiling which are secured with screws in blind rivets in the top of the commissioning box, or by means of the mounting brackets on the sides of the commissioning box for attachment to mounting strips or wires. See Figures 1 and 2.

Cut an appropriate opening for air diffusers according to the dimension table. Secure the active slot diffusers with screws to the commissioning box by means of the fixed mounting brackets in the diffuser face and the commissioning box respectively. Install the passive diffuser sections and end diffuser sections by screwing a threaded rod (hanger) into the blind rivet of the cover plate. As an alternative, wire or mounting strips can be secured with screws directly into the cover plate. For wall-to-wall installation, jointing pieces are included in the supply for aligning the diffuser sections in a straight line. The jointing pieces are mounted in one end of each diffuser section. Installation: See Figure 6c, step 7.

Commissioning

Prior to commissioning, you can change the direction of air discharge from the diffuser slots, see Figures 4 and 5. The diffuser face must be mounted in the commissioning box before you begin commissioning the system. Pull the measuring tubes and damper-adjustment cords out of the air diffuser through the slots, blue measuring tube for supply air and transparent tube for extract air, see Figure 3. When you have finished measuring the air pressure and have determined the appropriate damper position, stretch both damper-adjustment cords and tie them together in a so-called commissioning knot.

K-factors are specified in the relevant commissioning instructions at www.swegon.com.

Maintenance

Clean the air diffuser if needed with lukewarm water and dishwashing detergent added. Or use a vacuum cleaner with a brush nozzle for cleaning. The duct system can be accessed after removing the diffuser face and the damper assembly, see Figure 3.

Environment

The Building Materials Declaration is available from www.swegon.com.

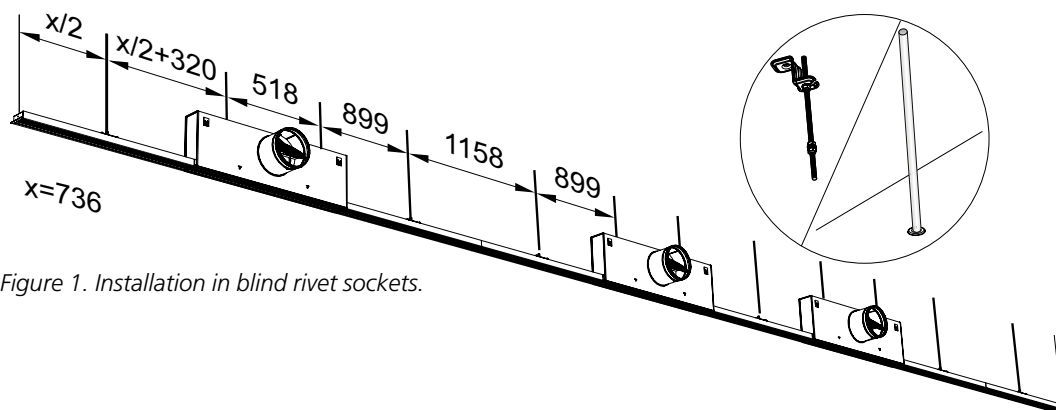

Figure 1. Installation in blind rivet sockets.

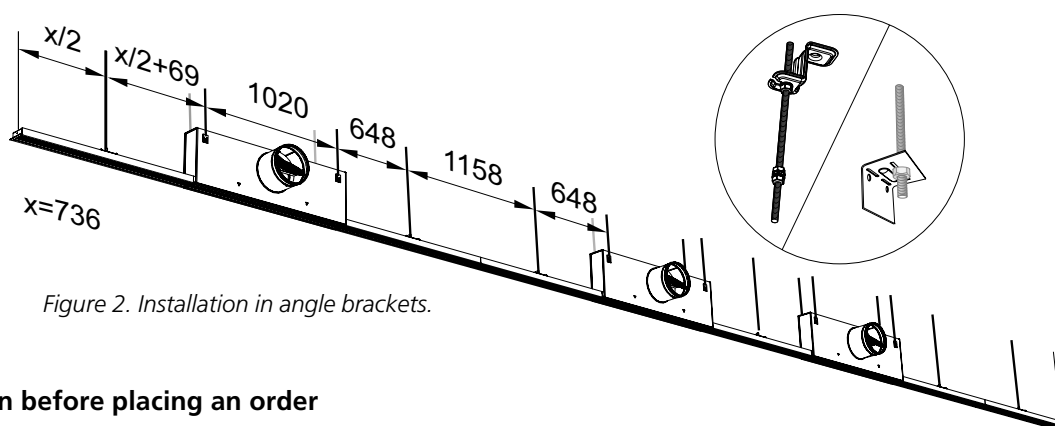

Figure 2. Installation in angle brackets.

Wall-to-wall calculation before placing an order

Example:

Installation of 10 m long linear slot diffusers which of three are active.

Calculate the number of complete modules (1158 mm). Recalculate 10 m to millimetres and divide by the module length:

$$10 \times 1000 / 1158 = 8.636 = 8 + 0.636$$

Check that the length of the SWAN END air diffusers will be sufficient, i.e. between 579 and 1174 mm:

$$1158 \times 0.636 = 736 \text{ mm}$$

736 mm is left over, which is not enough for two SWAN END air diffusers.

Recalculate:

Add a whole module, which gives $1158 + 736 = 1894 \text{ mm}$ (= 2 x 947).

Two end air diffusers, each 947 mm long.

Seven 1158 modules to be distributed as active SWAN ACT and passive SWAN PASS linear slot air diffusers.

Order:

- Four SWAN PASS, length: 1158 mm.
- Three are SWAN ACT, length: 1158 mm.
- Three SWAN Ta commissioning boxes for active diffusers.
- Two SWAN END passive end modules, length: 947 mm (includes an end-piece, 16 mm).

Calculation check: $(7 \times 1158) + (947 \times 2) = 10\,000 \text{ mm}$

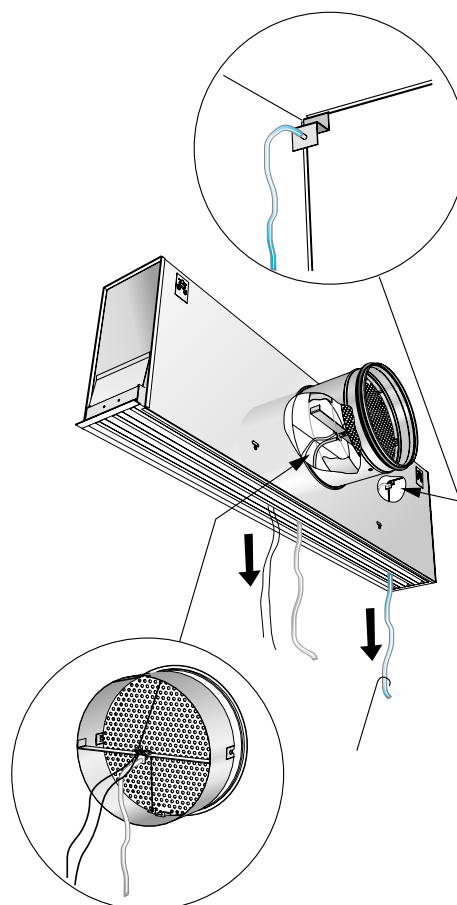

Figure 3. Measurement tappings for commissioning.

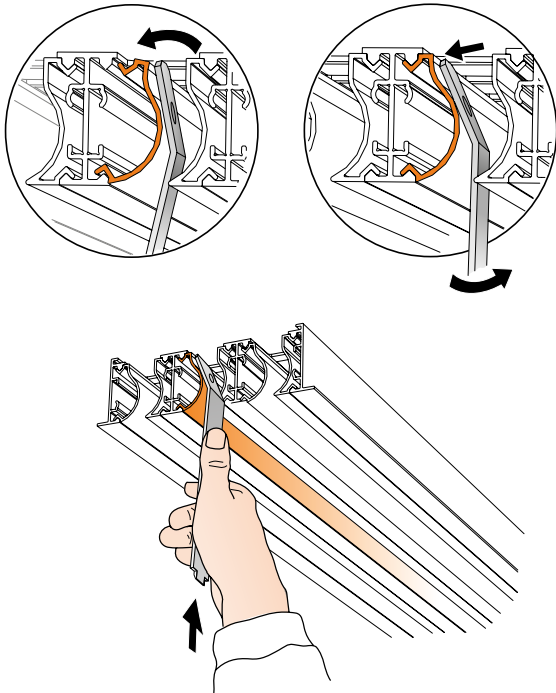

Figure 4a. Installing of the air deflectors.

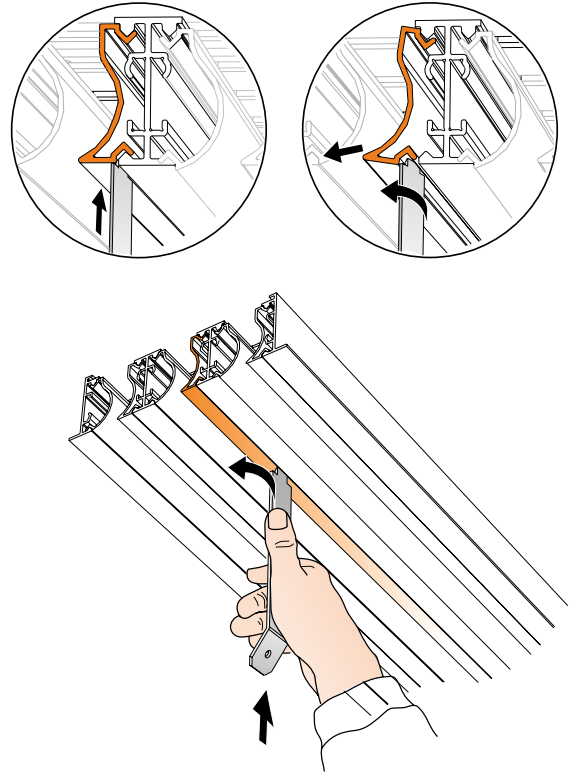

Figure 4b. Dismantle of the air deflectors.

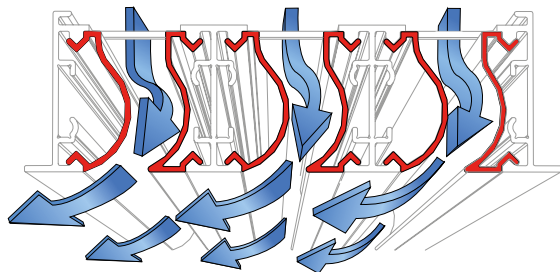

Figure 5a. 1-way air discharge.

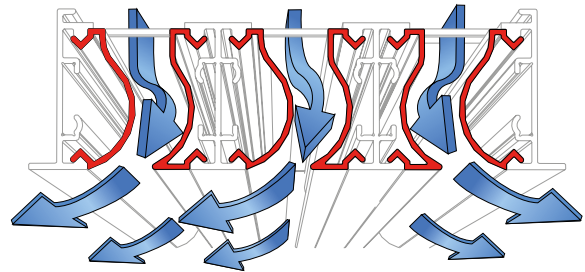

Figure 5b. 2-way air discharge.

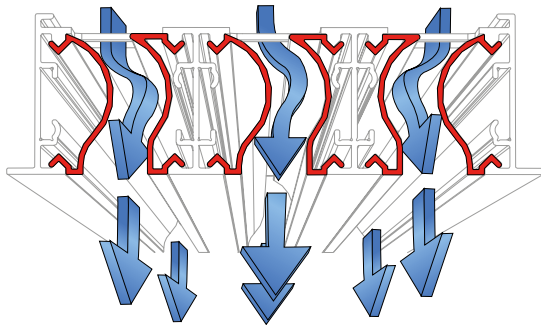

Figure 5c. Vertical air discharge.

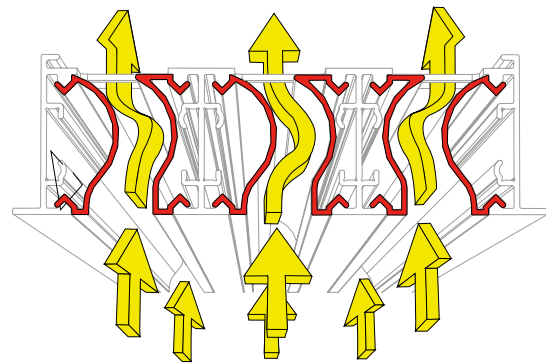

Figure 5d. Extract air.

Installation example:

According to Figures 6a-6d

1. Measure the location of the commissioning boxes and the slot diffusers.
2. Start by mounting the commissioning boxes (the products are supplied without mounting accessories).
3. Then install the first slot diffuser, which is a SWAN END. (end- piece in the left end and jointing piece in the right end)

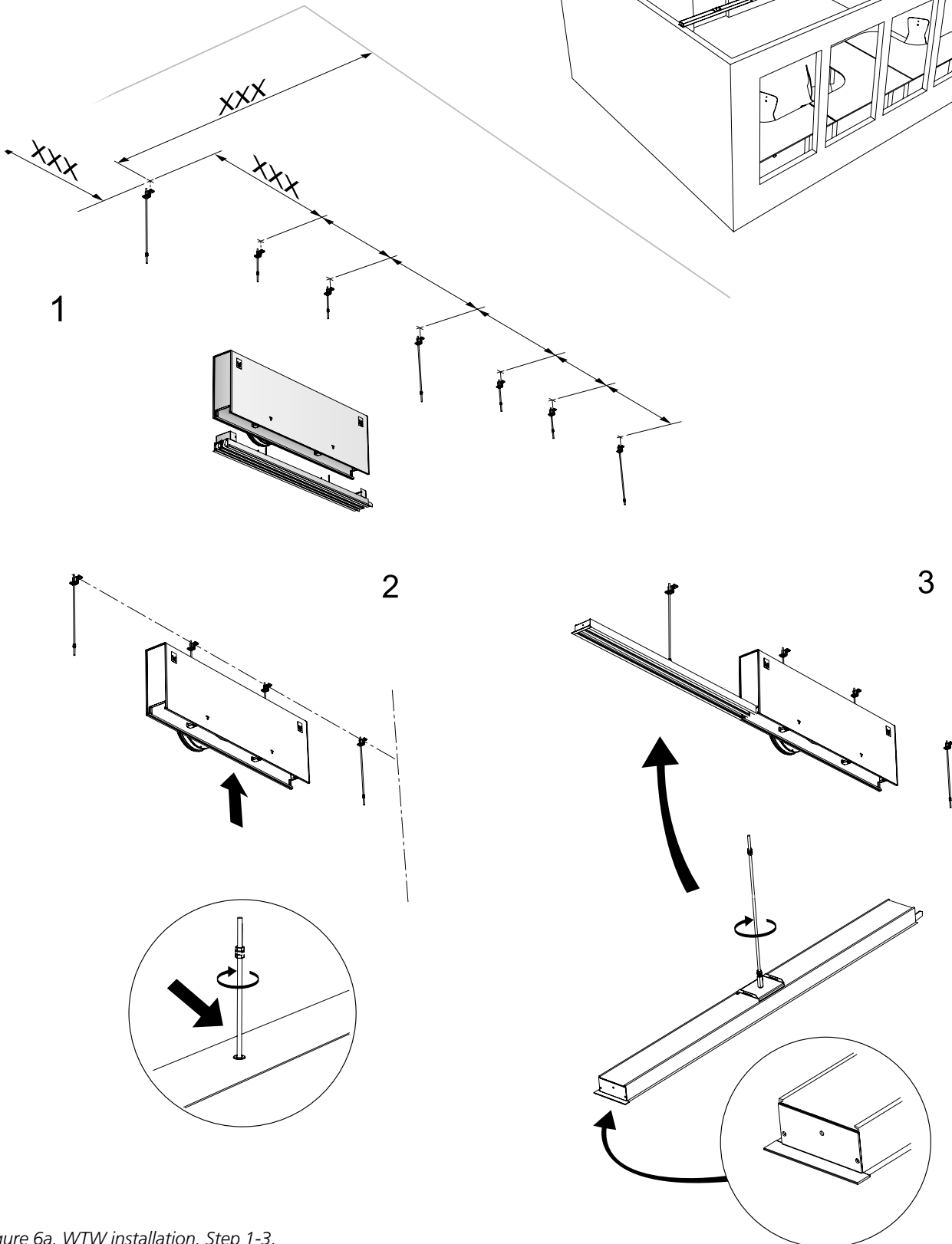
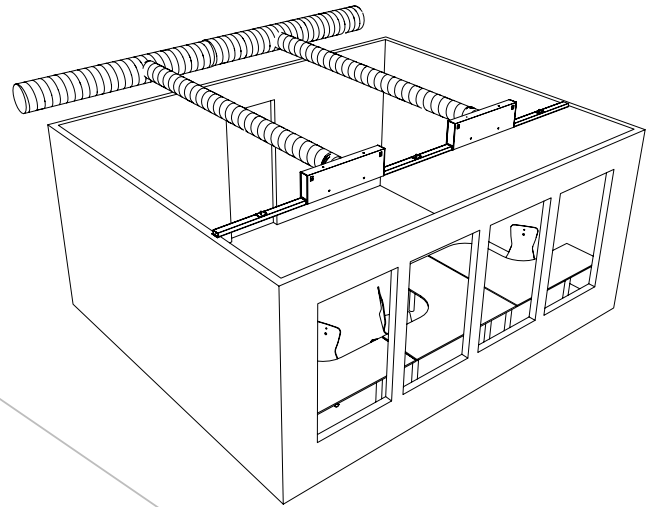

Figure 6a. WTW installation, Step 1-3.

- 4 & 5. Remove the outer air deflectors from the next diffuser (which is an active slot diffuser) to enable you to access and tighten the locking screw against the jointing pieces.
6. Install the SWAN ACT active slot diffuser against the SWAN END's jointing piece and secure the diffuser against the commissioning box with screws.

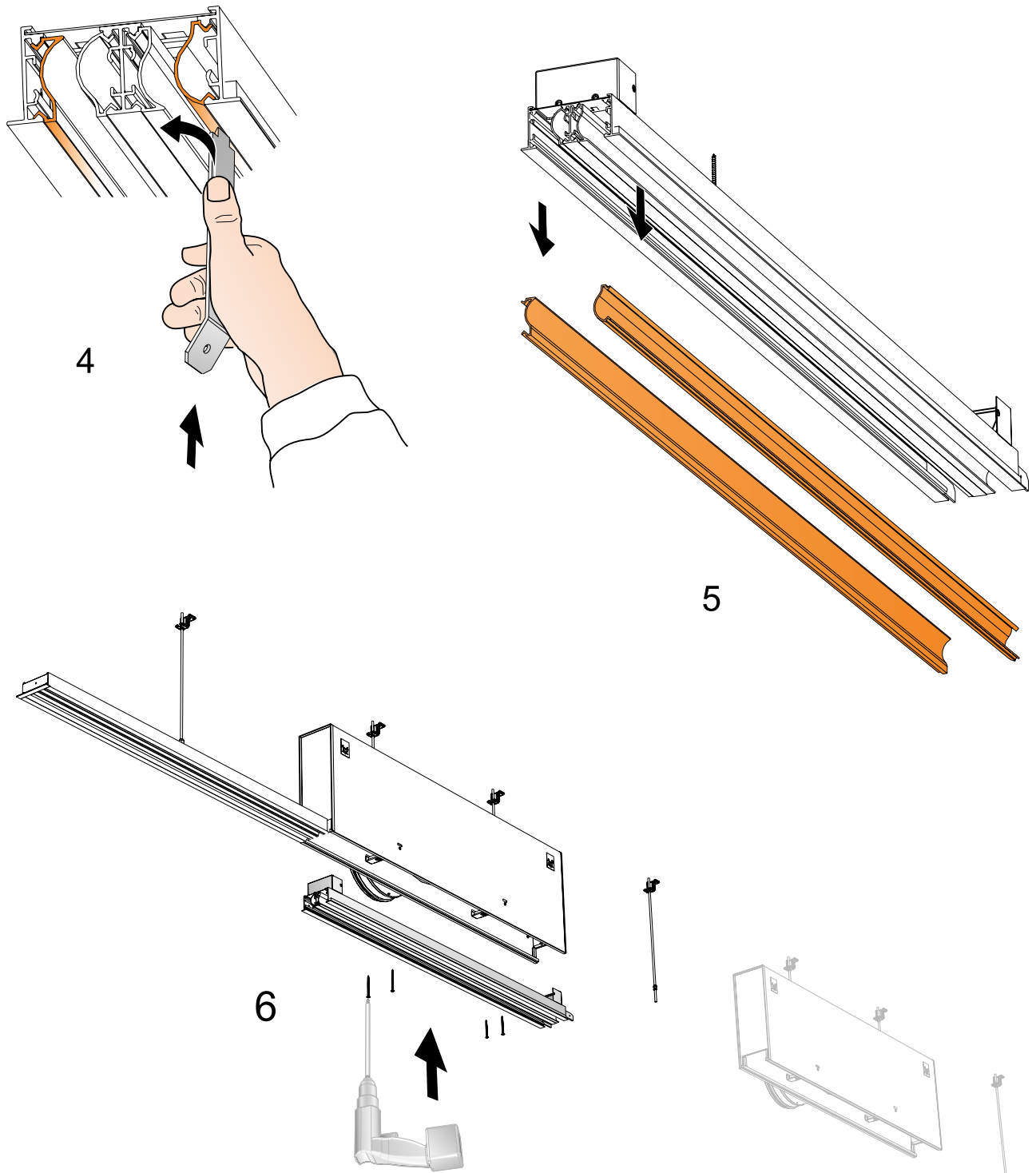

Figure 6b. WTW installation, Step 4-6.

7. Adjust the slot diffuser ends against each other in order to obtain a good joint between the diffusers and lock the jointing pieces with a hexagon spanner (size: 2 mm).

8. Refit the air deflectors into the SWAN ACT slot diffuser and remove the outer air deflectors on the next slot diffuser, in this case: a SWAN PASS which will be located between two commissioning boxes.

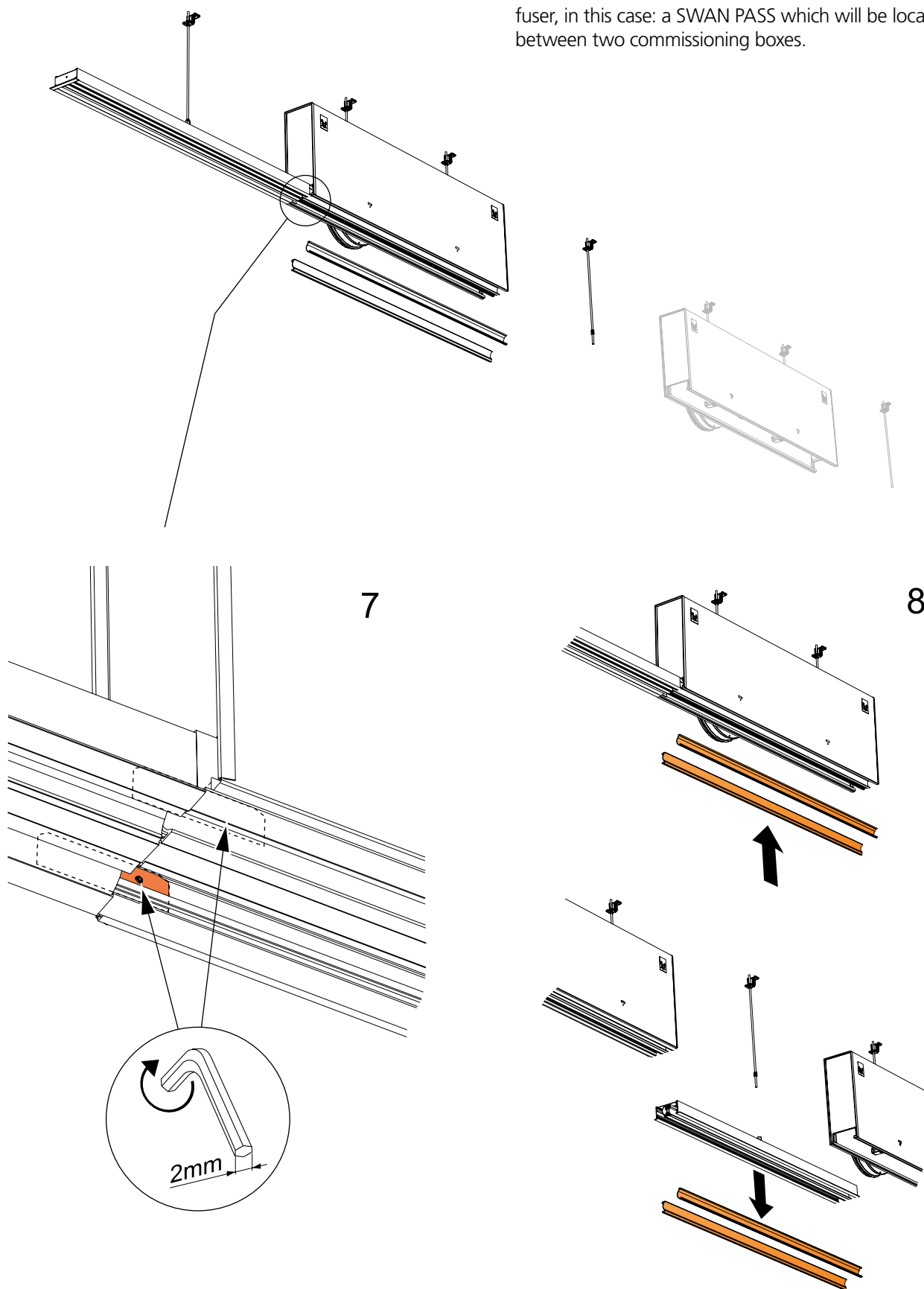

Figure 6c. WTW installation, Step 7 and 8.

- 9 & 10. Install the SWAN PASS slot diffuser against the preceding slot diffuser and lock the jointing pieces as shown in Item 7.
11. Refit the air deflectors in the SWAN PASS slot diffuser.

Then continue the installation with the next active slot diffuser, in the same way as in Steps 4-8. The last slot diffuser is a SWAN END which in this case should be installed against the other active slot diffuser. It might be necessary to remove the jointing pieces from this last SWAN END slot diffuser.

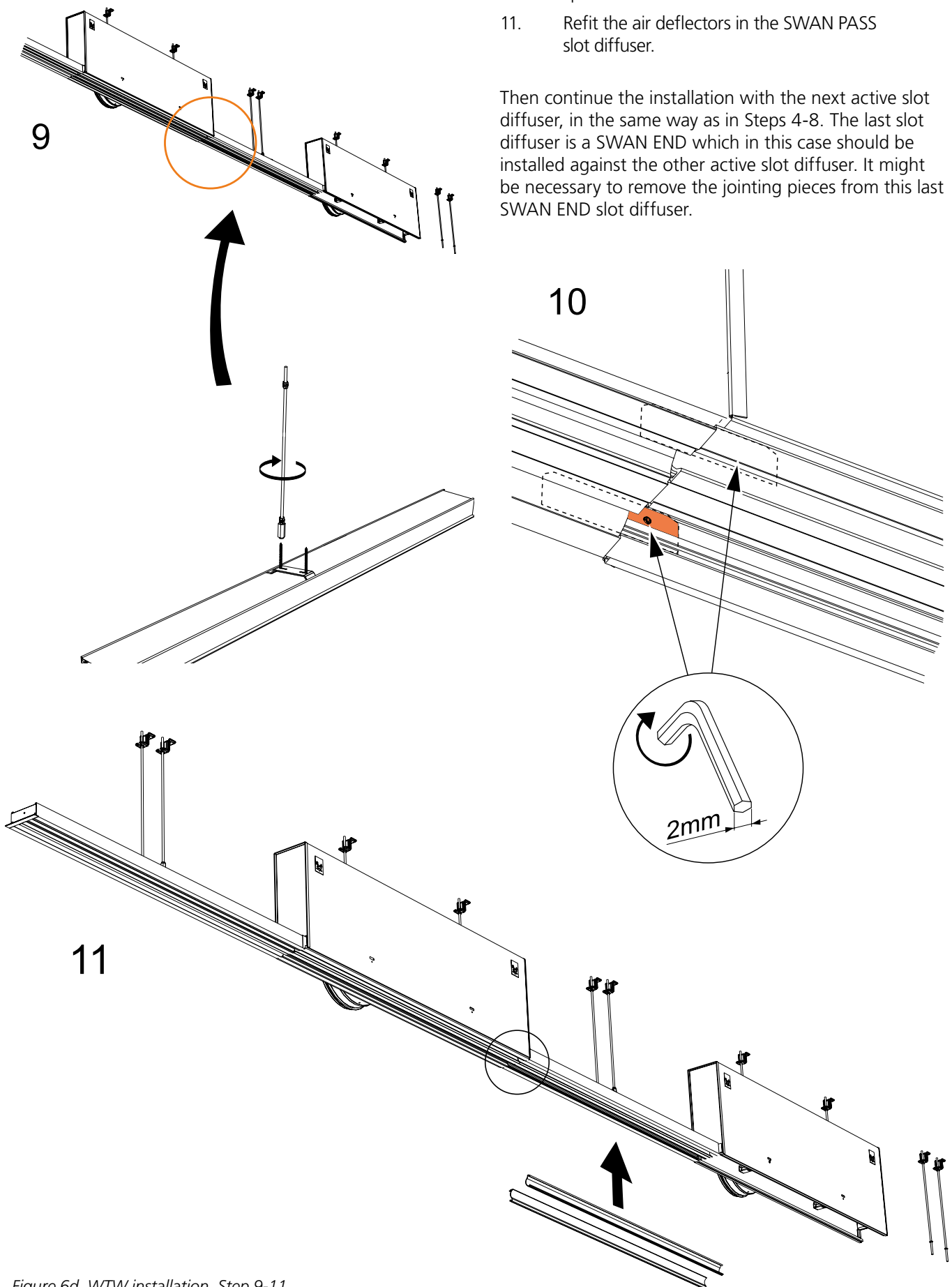

Figure 6d. WTW installation, Step 9-11.

Sizing

- Sound pressure level dB(A) applies to rooms with 10 m² equivalent sound absorption area.
- Sound attenuation (ΔL) below is shown in the octave band. Orifice attenuation is included in the values.
- The throw $l_{0,2}$ is measured under isothermal discharge conditions.
- The recommended max. permitted temperature below room temperature is 8 K.
- To calculate the air stream diffusion, air velocities in the occupied zone or sound levels in rooms with other dimensions, please refer to our ProAir web computer program at www.swegon.com.

- N.B.! Technical data applies for SWAN ACT active diffusers and are the same as for standard 1200 mm (1158 mm + end-pieces).

L_w = Sound power level

L_{p10A} = Sound pressure level dB (A)

K_{ok} = Correction for producing the L_w value in the octave band

$L_w = L_{p10A} + K_{ok}$ gives the frequency divided octave band

Acoustic data

SWAN ACT + SWAN T – Supply air

1-way and 2-way air discharge

Sound power level L_w (dB)

Table K_{ok}

Size SWAN ACT	Mid-frequency (Octave band) Hz							
	63	125	250	500	1000	2000	4000	8000
2-160	-6	7	7	0	-5	-9	-15	-22
2-200	-5	7	8	0	-4	-9	-14	-19
2-250	-1	8	8	1	-3	-10	-16	-23
3-160	-6	7	7	-1	-4	-7	-13	-19
3-200	-3	6	6	-2	-4	-8	-13	-18
3-250	-1	7	8	0	-4	-9	-15	-20
4-160	-5	6	6	-3	-4	-7	-13	-20
4-200	-4	6	6	-2	-3	-8	-12	-18
4-250	-1	8	7	-2	-5	-9	-14	-19
Tol. ±	2	2	2	2	2	2	2	2

Sound attenuation ΔL (dB), without sound absorber in the SWAN T

Table ΔL, 1-way, 2-way and vertical

Size SWAN ACT	Mid-frequency (Octave band) Hz							
	63	125	250	500	1000	2000	4000	8000
2-160	12	9	6	6	8	9	6	8
2-200	11	9	6	6	9	11	6	9
2-250	12	8	7	6	10	11	7	10
3-160	13	8	6	6	8	7	5	7
3-200	11	8	6	6	9	8	5	7
3-250	10	7	7	6	9	9	6	9
4-160	12	8	6	5	7	5	5	7
4-200	11	7	5	6	7	6	5	7
4-250	10	7	6	7	7	7	5	7
Tol. ±	2	2	2	2	2	2	2	2

SWAN ACT + SWAN T – Supply air

Vertical air discharge

Sound power level L_w (dB)

Table K_{ok}

Size SWAN ACT	Mid-frequency (Octave band) Hz							
	63	125	250	500	1000	2000	4000	8000
2-160	-5	8	8	-1	-6	-9	-15	-22
2-200	-4	8	9	0	-3	-9	-14	-20
2-250	1	10	8	1	-3	-10	-16	-24
3-160	-7	7	8	-1	-4	-8	-13	-20
3-200	-4	7	8	-1	-4	-9	-13	-19
3-250	0	7	9	0	-3	-8	-14	-22
4-160	-5	6	7	-2	-5	-8	-15	-20
4-200	-3	6	8	-1	-4	-9	-13	-19
4-250	0	8	8	-1	-4	-9	-14	-20
Tol. ±	2	2	2	2	2	2	2	2

Sound Attenuation ΔL (dB), with sound absorber in the SWAN T

Table ΔL, 1-way, 2-way and vertical

Size SWAN ACT	Mid-frequency (Octave band) Hz							
	63	125	250	500	1000	2000	4000	8000
2-160	12	7	8	8	14	16	12	14
2-200	11	8	8	9	15	16	11	14
2-250	11	8	9	10	14	16	13	17
3-160	12	8	6	8	14	11	10	12
3-200	10	8	7	8	13	13	10	13
3-250	11	8	8	9	13	13	12	16
4-160	12	7	7	7	12	10	9	13
4-200	9	8	7	9	12	10	9	13
4-250	11	6	8	9	12	11	11	15
Tol. ±	2	2	2	2	2	2	2	2

SWAN ACT + SWAN T – Extract air

Sound power level L_w (dB)

Table K_{ok}

Size SWAN ACT	Mid-frequency (Octave band) Hz							
	63	125	250	500	1000	2000	4000	8000
2-160	-8	8	6	0	-3	-6	-11	-20
2-200	-4	7	6	-2	-4	-6	-13	-22
2-250	-4	7	6	-1	-3	-6	-17	-25
3-160	-8	5	4	0	-3	-4	-11	-20
3-200	-7	6	4	-1	-2	-5	-11	-19
3-250	-5	8	6	-2	-3	-6	-14	-23
4-160	-8	7	4	-2	-3	-4	-11	-20
4-200	-9	6	3	-2	-2	-5	-13	-22
4-250	-3	8	4	-2	-2	-6	-15	-23
Tol. \pm	2	2	2	2	2	2	2	2

Sound attenuation ΔL (dB), without sound absorber in the SWAN T

Table ΔL

Size SWAN ACT	Mid-frequency (Octave band) Hz							
	63	125	250	500	1000	2000	4000	8000
2-160	12	9	6	6	8	9	6	8
2-200	11	9	6	6	9	11	6	9
2-250	12	8	7	6	10	11	7	10
3-160	13	8	6	6	8	7	5	7
3-200	11	8	6	6	9	8	5	7
3-250	10	7	7	6	9	9	6	9
4-160	12	8	6	5	7	5	5	7
4-200	11	7	5	6	7	6	5	7
4-250	10	7	6	7	7	7	5	7
Tol. \pm	2	2	2	2	2	2	2	2

Sound attenuation ΔL (dB), with sound absorber in the SWAN T

Table ΔL

Size SWAN ACT	Mid-frequency (Octave band) Hz							
	63	125	250	500	1000	2000	4000	8000
2-160	12	7	8	8	14	16	12	14
2-200	11	8	8	9	15	16	11	14
2-250	11	8	9	10	14	16	13	17
3-160	12	8	6	8	14	11	10	12
3-200	10	8	7	8	13	13	10	13
3-250	11	8	8	9	13	13	12	16
4-160	12	7	7	7	12	10	9	13
4-200	9	8	7	9	12	10	9	13
4-250	11	6	8	9	12	11	11	15
Tol. \pm	2	2	2	2	2	2	2	2

Sizing diagram

SWAN ACT – Supply air

Airflow - Pressure drop - Sound level – Throw

- The diagrams illustrate data for a SWAN ACT recessed in a ceiling.
- The diagrams should not be used for commissioning.
- The dB(A) values are for rooms with normal acoustic absorption (4 dB room attenuation).
- The dB(C) value is normally 6-9 dB higher than the dB(A) value.
- ∇ = Min. airflow required for obtaining sufficient commissioning pressure.

SWAN ACT – Supply air, 1-way and 2-way

SWAN ACT 2-1158 + SWAN T 2-160

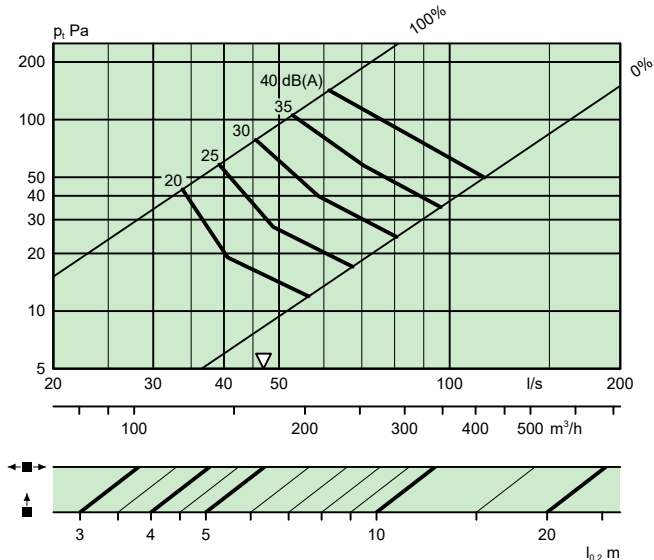

SWAN ACT 2-1158 + SWAN T 2-200

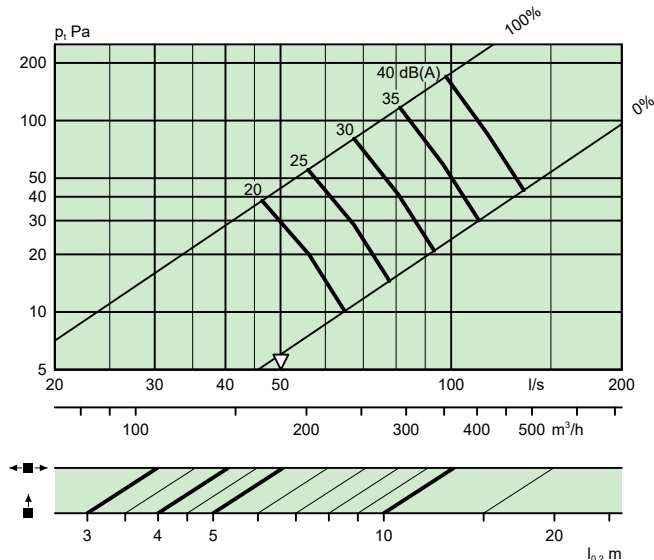

SWAN ACT 2-1158 + SWAN T 2-250

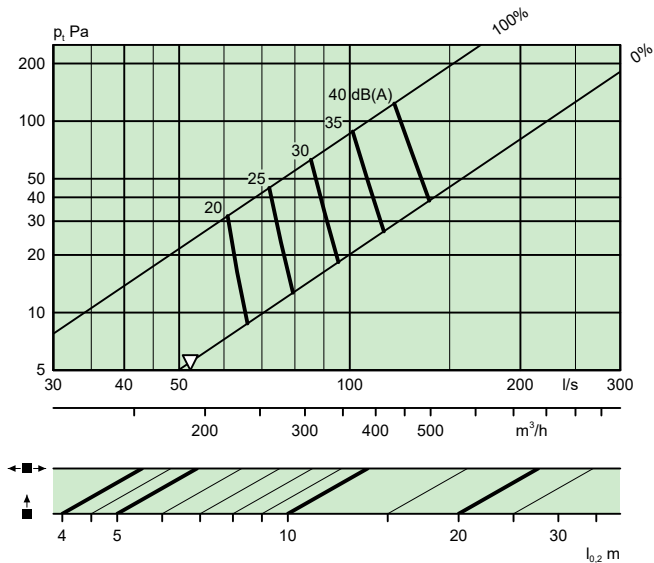

SWAN ACT 3-1158 + SWAN T 3-160

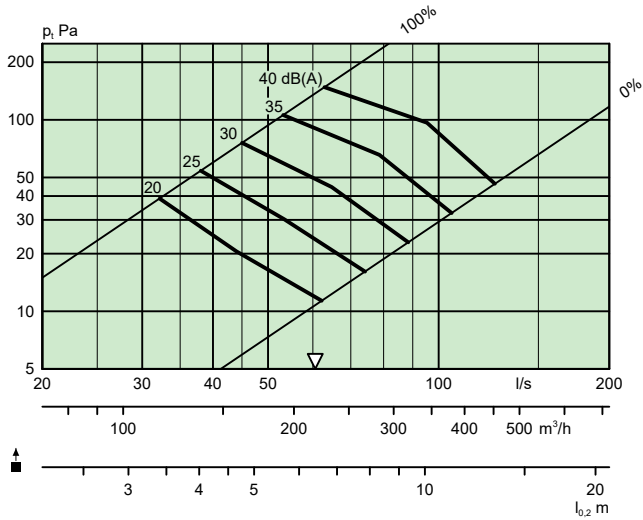

SWAN ACT 3-1158 + SWAN T 3-200

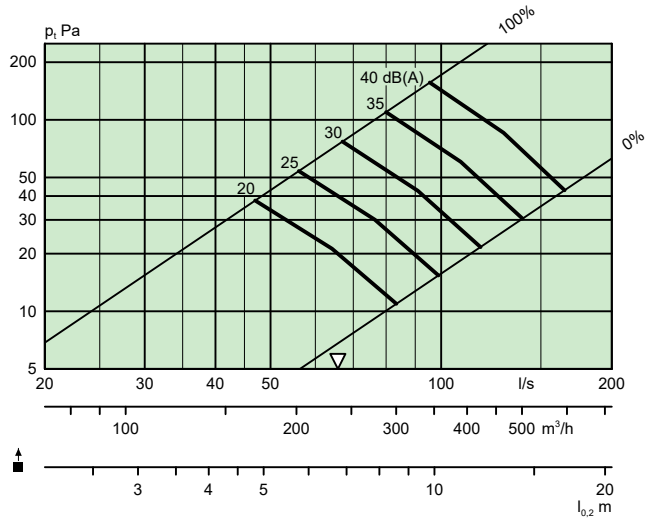

SWAN ACT 3-1158 + SWAN T 3-250

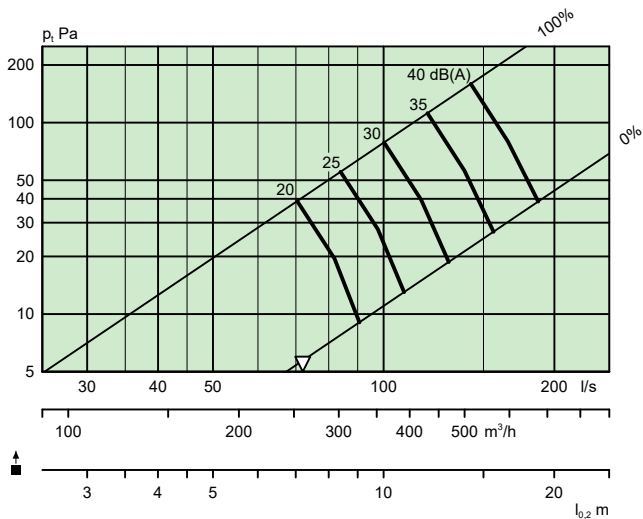

SWAN ACT 4-1158 + SWAN T 4-160

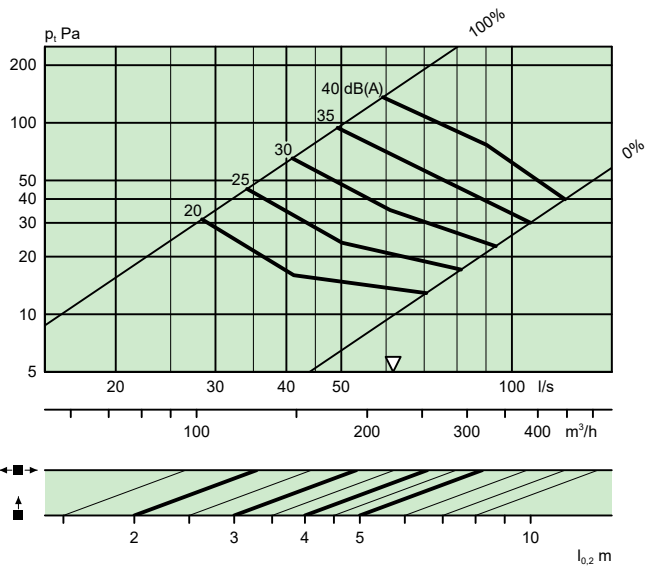

SWAN ACT 4-1158 + SWAN T 4-200

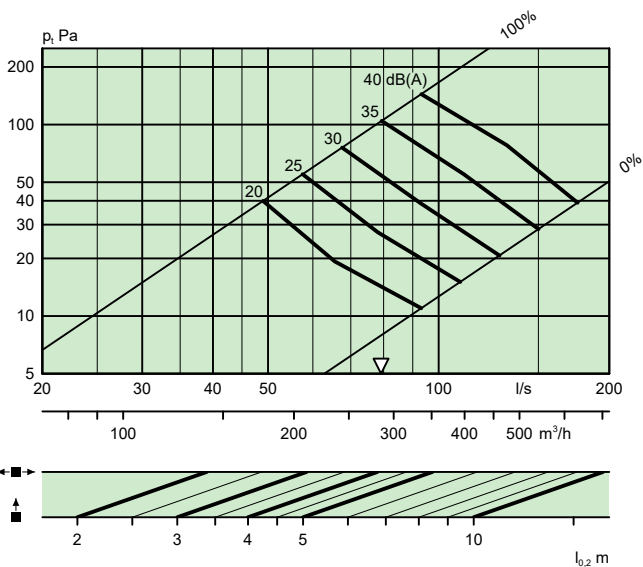

SWAN ACT 4-1158 + SWAN T 4-250

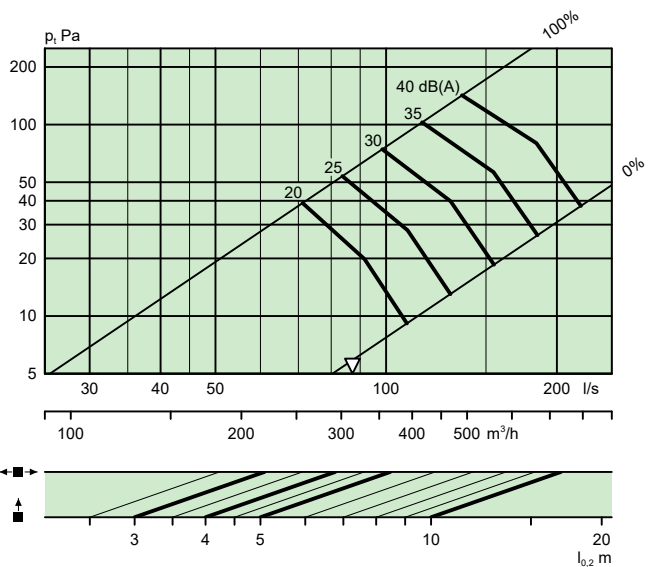

SWAN ACT – Supply air, vertical air discharge

SWAN ACT 2-1158 + SWAN T 2-160

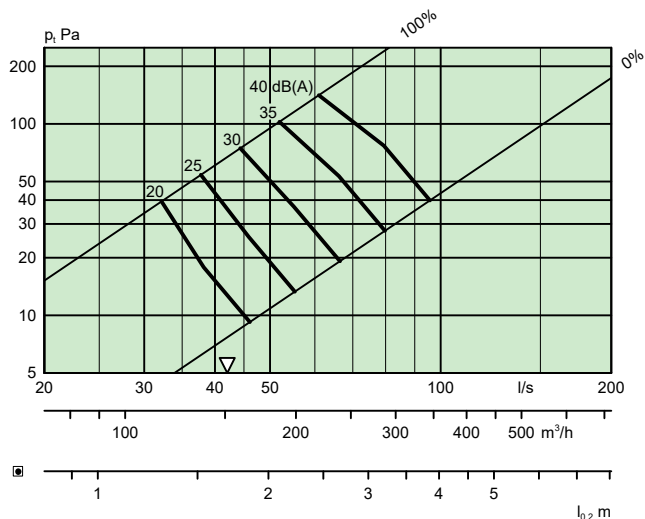

SWAN ACT 2-1158 + SWAN T 2-200

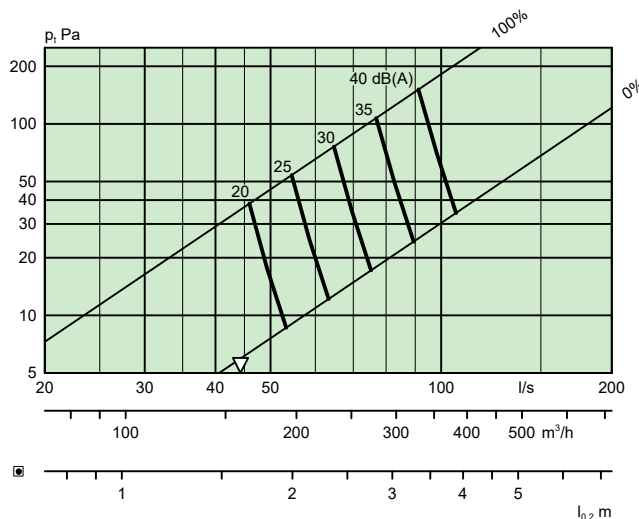

SWAN ACT 2-1158 + SWAN T 2-250

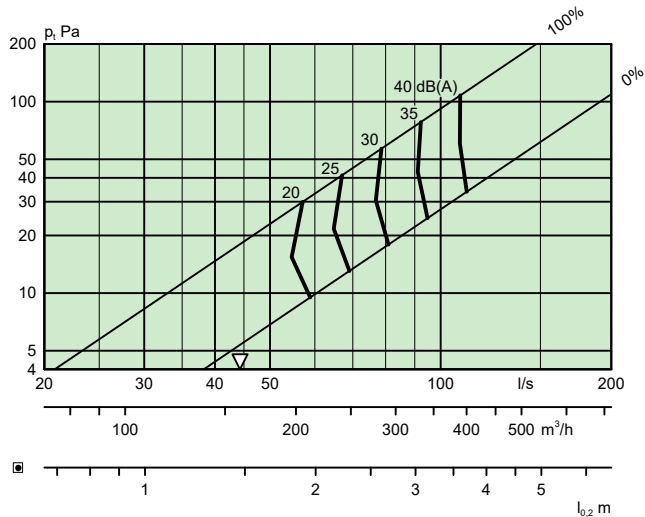

SWAN ACT 3-1158 + SWAN T 3-160

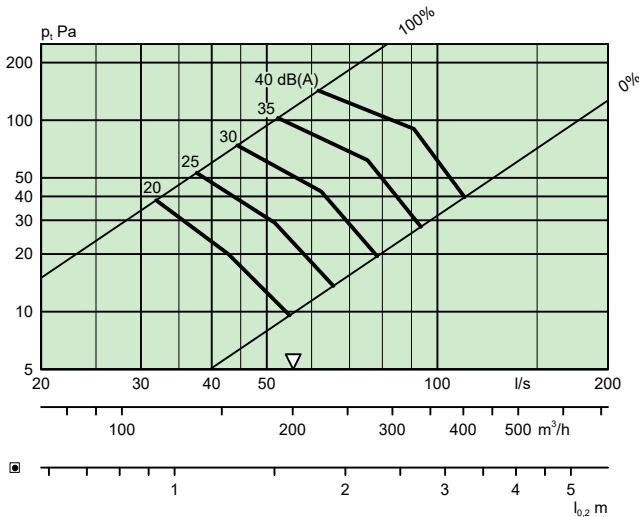

SWAN ACT 3-1158 + SWAN T 3-200

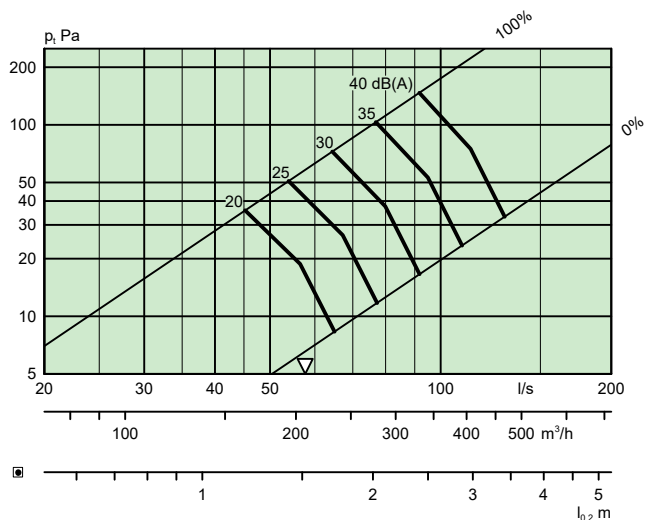

SWAN ACT 3-1158 + SWAN T 3-250

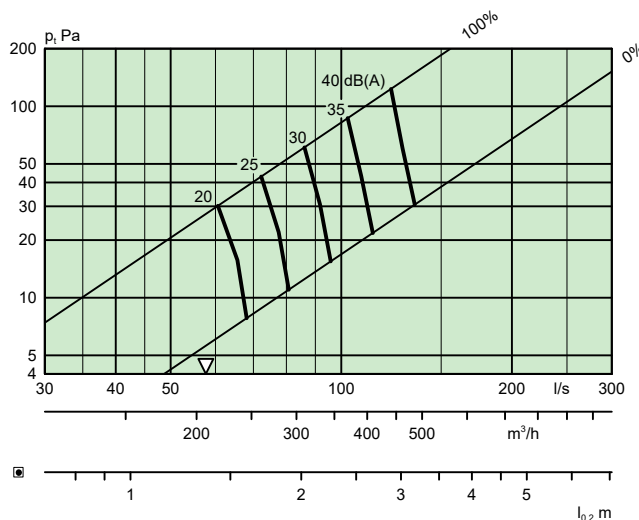

SWAN ACT 4-1158 + SWAN T 4-160

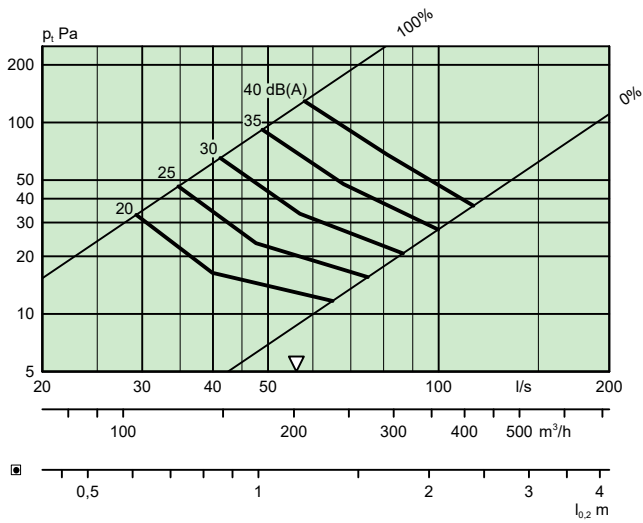

SWAN ACT 4-1158 + SWAN T 4-200

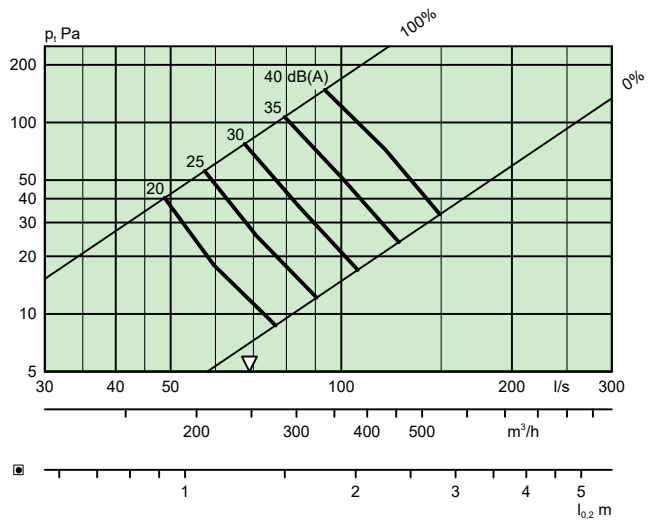

SWAN ACT 4-1158 + SWAN T 4-250

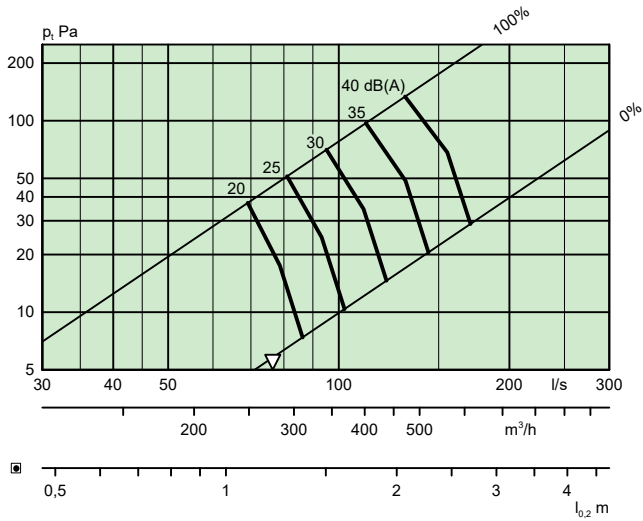

Sizing diagram – SWAN ACT – Extract air

Airflow - Pressure drop - Sound level

- The diagrams illustrate data for a SWAN ACT for flush installation.
- The diagrams should not be used for commissioning.
- The dB(A) values are for rooms with normal acoustic absorption (4 dB room attenuation).
- The dB(C) value is normally 6-9 dB higher than the dB(A) value.
- ∇ = Min. airflow required for obtaining sufficient commissioning pressure.

SWAN ACT 2-1158 + SWAN T 2-160

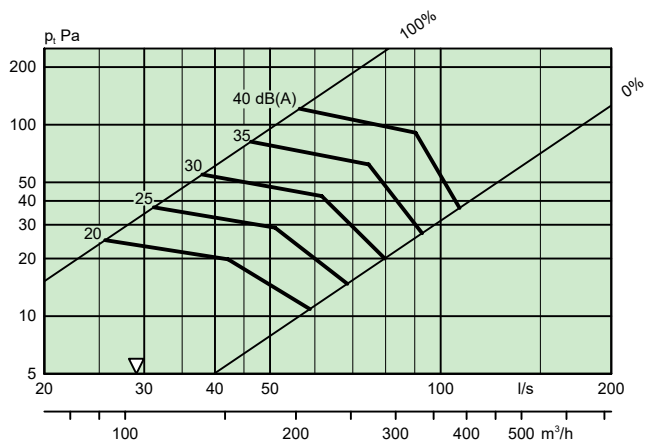

SWAN ACT 2-1158 + SWAN T 2-200

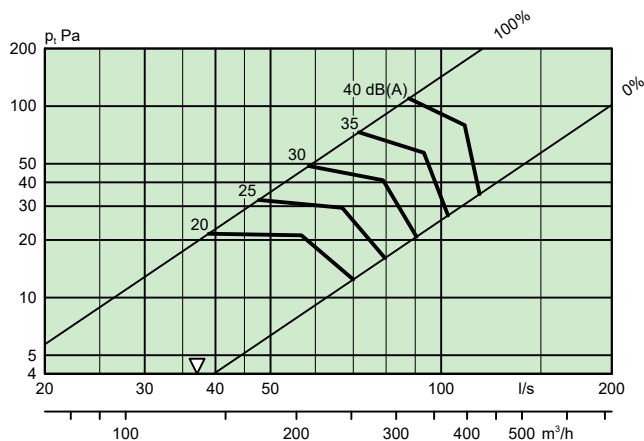

SWAN ACT 2-1158 + SWAN T 2-250

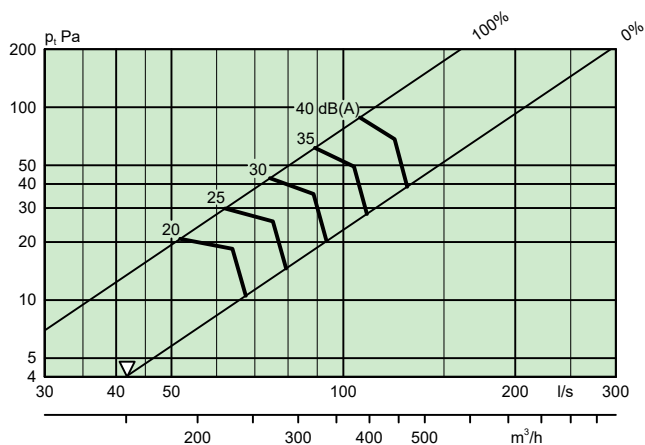

SWAN ACT 3-1158 + SWAN T 3-160

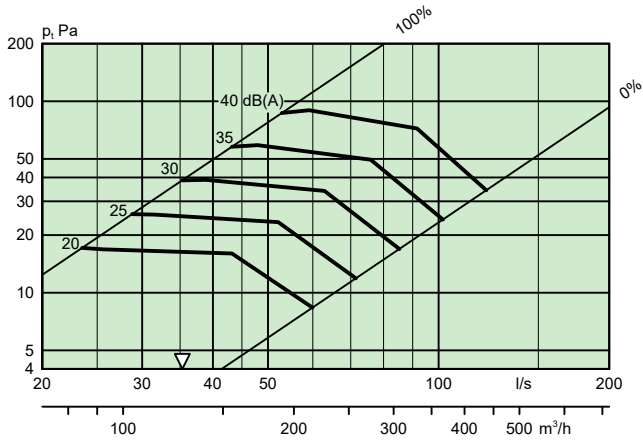

SWAN ACT 3-1158 + SWAN T 3-200

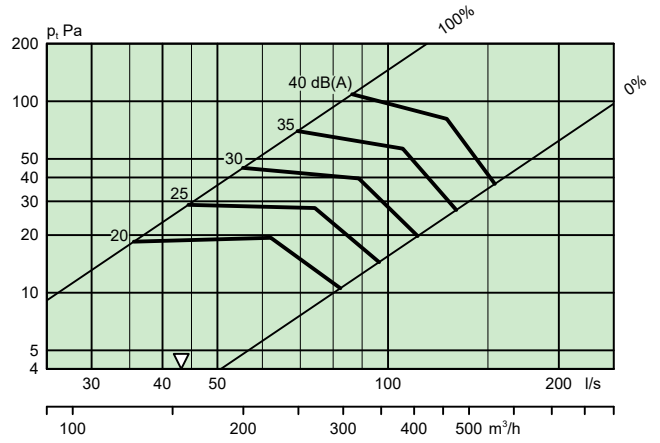

SWAN ACT 3-1158 + SWAN T 3-250

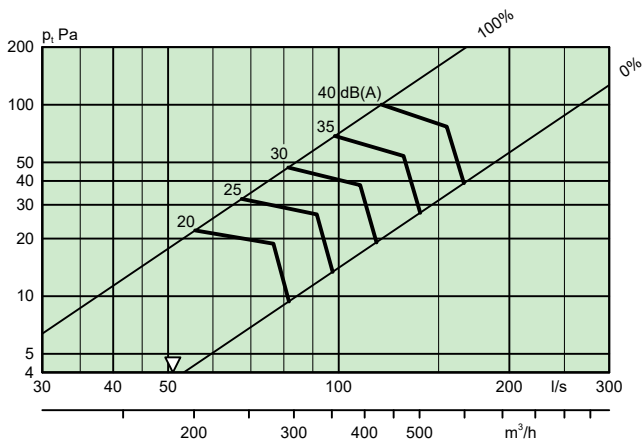

SWAN ACT 4-1158 + SWAN T 4-160

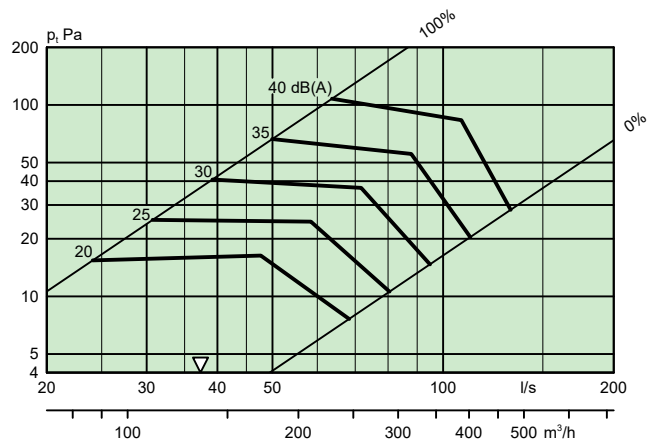

SWAN ACT 4-1158 + SWAN T 4-200

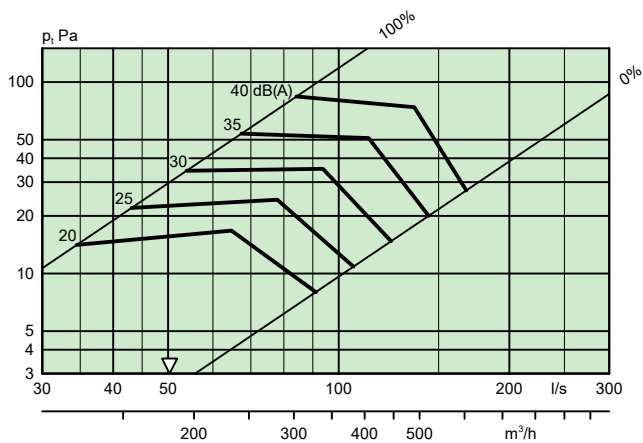

SWAN ACT 4-1158 + SWAN T 4-250

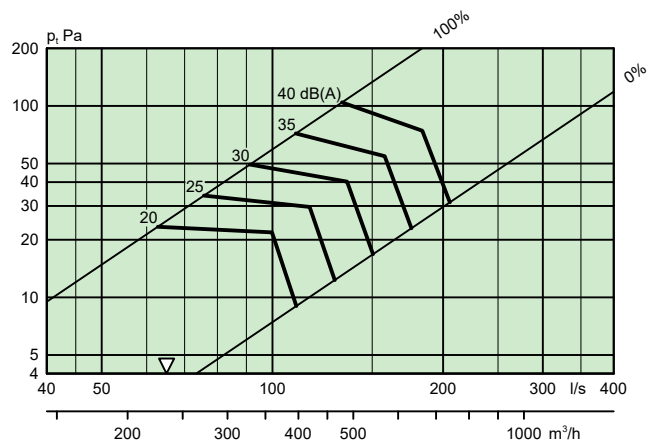

Dimensions and weights

SWAN WTW - Dimensions (mm)

Size	A	A1	B	B1	ØD	H-(H+25)	J	K	L
2-1158-160	1158	200	107	92	159	265-290	124	1151	146
2-1158-200	1158	200	107	92	199	304-329	124	1151	166
2-1158-250	1158	200	107	92	249	354-379	124	1151	194
3-1158-160	1158	245	153	137	159	265-290	170	1151	146
3-1158-200	1158	245	153	137	199	304-329	170	1151	166
3-1158-250	1158	245	153	137	249	354-379	170	1151	194
4-1158-160	1158	290	198	182	159	265-290	215	1151	146
4-1158-200	1158	290	198	182	199	304-329	215	1151	166
4-1158-250	1158	290	198	182	249	354-379	215	1151	194

Holemaking size: length = X -32 mm. Width = B -12 mm.

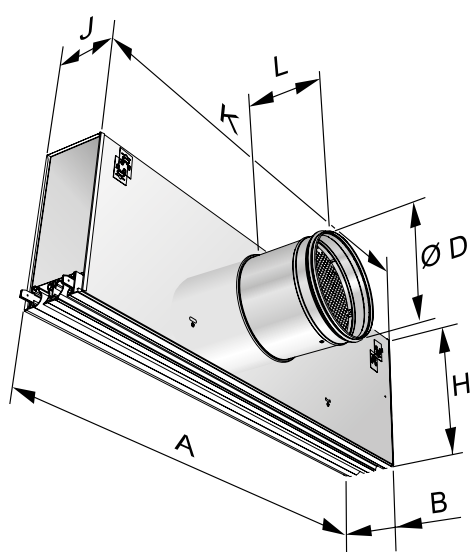

Figure 7. SWAN ACT with SWAN T.

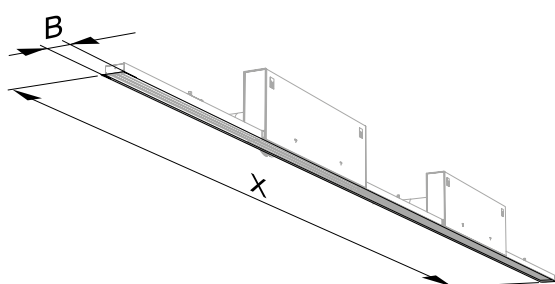

Figure 8. SWAN WTW, overview in a room

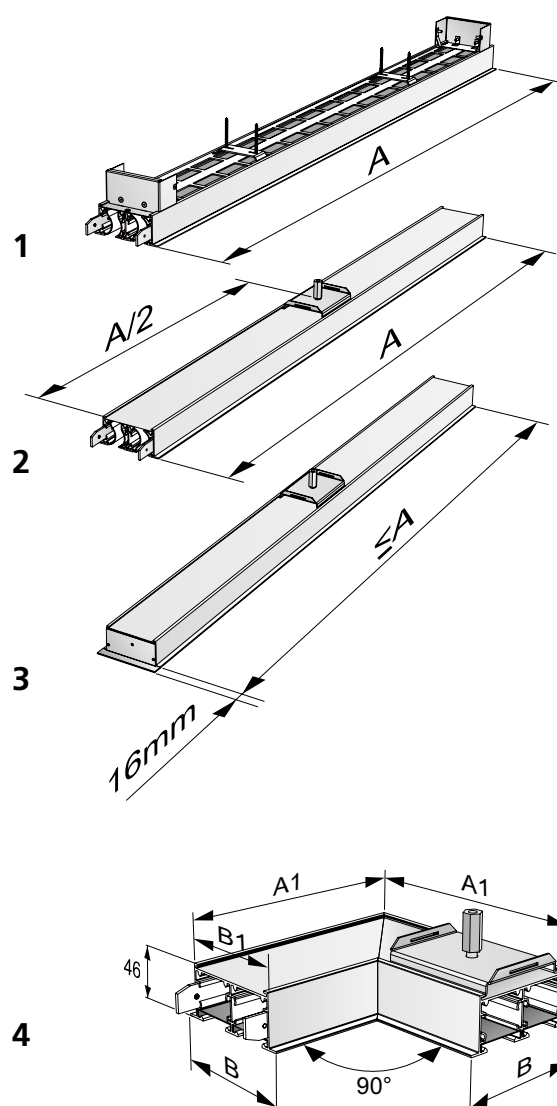
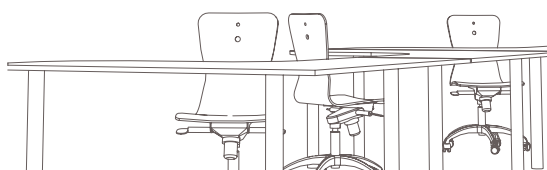

Figure 9. SWAN WTW, parts included:
 1) SWAN ACT
 2) SWAN PASS
 3) SWAN END
 4) SWAN CORN90 (accessory)

SWAN T – Location, duct connection (mm)

SWAN T	P	R	S
Ø160 mm	102	22	163
Ø200 mm	122	22	182
Ø250 mm	147	22	207

SWAN WTW – Weight, parts included (kg)

Size	SWAN ACT	SWAN PASS	SWAN END ^{*)}	SWAN T
2-1158-160	2,6	2,8	1,4 - 2,8	4.2
2-1158-200	2,6	2,8	1,4 - 2,8	4.9
2-1158-250	2,6	2,8	1,4 - 2,8	5.9
3-1158-160	3,6	4,0	2,0 - 4,0	5.2
3-1158-200	3,6	4,0	2,0 - 4,0	5.8
3-1158-250	3,6	4,0	2,0 - 4,0	6.7
4-1158-160	4,6	5,3	2,7 - 5,3	6.0
4-1158-200	4,6	5,3	2,7 - 5,3	6.7
4-1158-250	4,6	5,3	2,7 - 5,3	7.7

^{*)} SWAN END, min. weight for A=579 and max. weight for A=1158

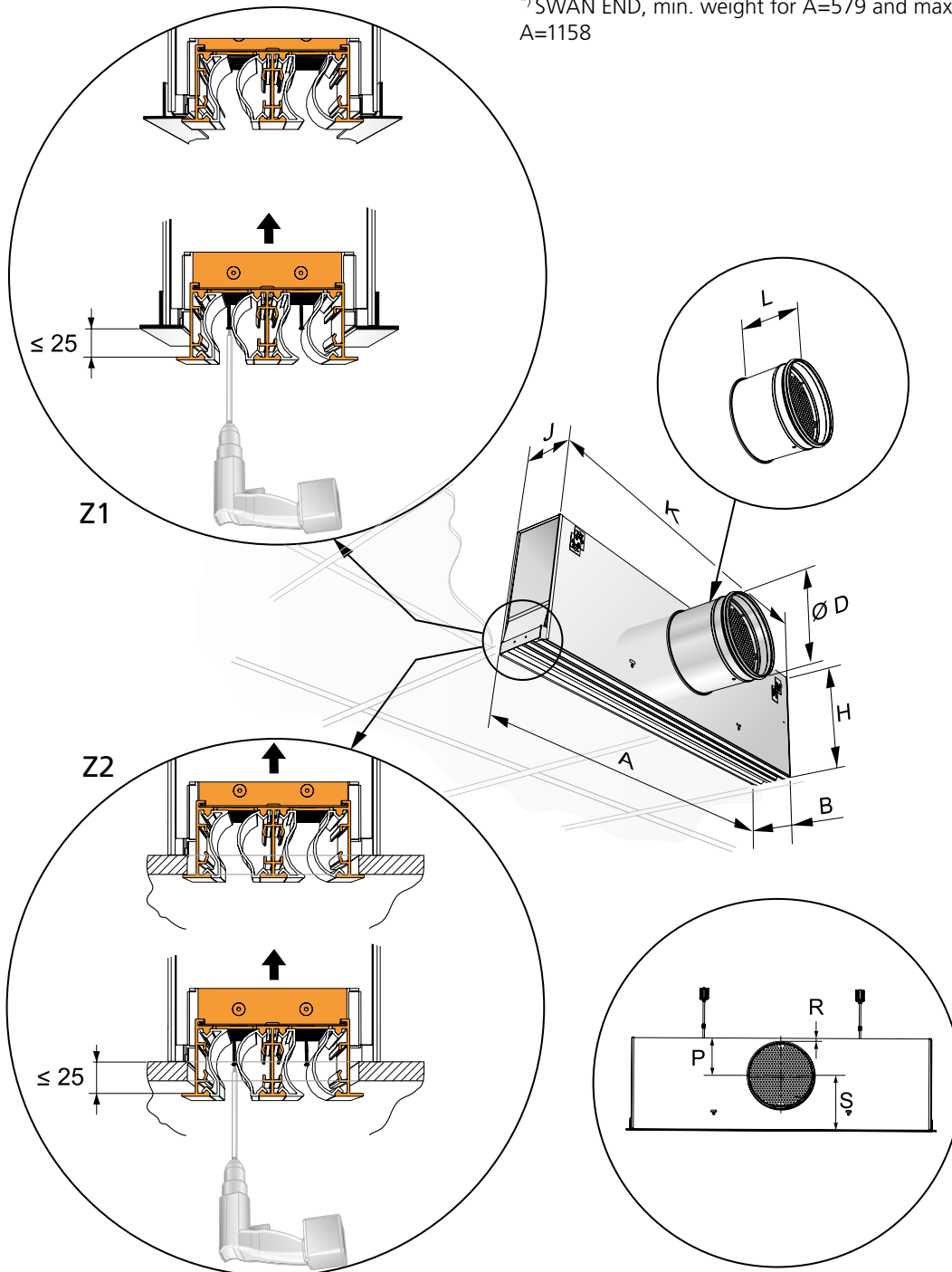

Figure 8. SWAN WTW with SWAN T commissioning box. Z1 = False ceilings, Z2 = Plasterboard ceilings.

Ordering key

Product – SWAN WTW

Active linear slot air diffuser SWAN a ACT -b -1158 -d

Version

ACT = Active air diffuser installed with SWAN T commissioning box

Number of slots: 2, 3, 4

Length: 1158 mm standard

Version: W = white

A = natural anodized

Note in plain text whether the active slot diffuser should have an end-piece.

Passive linear slot air diffuser SWAN a PASS -b -1158 -d

Version

Passive air diffuser with cover plate

Number of slots: 2, 3, 4

Length: 1158 mm standard

Version: W = white

A = natural anodized

End linear slot air diffuser SWAN a END -b -cccc -d

Version

End, passive air diffuser with cover plate and one end-piece

Number of slots: 2, 3, 4

Length: 579-1,174 mm

Version: W = white

A = natural anodized

Accessories^{*)}

Commissioning box, standard for active slot air diffusers SWAN T a -a -bbb

Version

Number of slots: 2, 3, 4 (1158 mm length)

Connecting duct dimension Ø: 160, 200, 250

Without sound absorber in the standard version.

With sound absorber; please specify this in plain text in the order.

Corner module SWAN a CORN90 -b -c

Version

Corner module, 90°, passive section with cover plate

Number of slots: 2, 3, 4

Version: W = white

A = natural anodized

^{*)}The products are supplied without mounting accessories. Mounting strips, hanger brackets/rods, ceiling mounting brackets etc. can be purchased from local suppliers.

Standard product range

For the SWAN WTW	2-1158-W	SWAN T	2-160 2-200 2-250
SWAN WTW	3-1158-W	SWAN T	3-160 3-200 3-250
SWAN WTW	4-1158-W	SWAN T	4-160 4-200 4-250

Specification text

Swegon's type SWAN WTW linear slot diffuser for wall-to-wall installation with commissioning boxes for active linear slot diffusers and in between them passive linear slot diffusers with the following features:

- Individually adjustable air deflectors made of ABS plastic.
- Natural anodized or white powder paint sprayed and baked white finish, RAL 9003/NCS S 0500-N
- Cleanable commissioning box with removable commissioning damper with lockable flow adjustment cords, measuring method with low systematic error.

Size	SWAN a ACT-3-1158-W	xx items
	SWAN a PASS 3-1158-W	xx items
	SWAN a END 3-650-W	xx items
	SWAN Ta 3-200	xx items
	SWAN a CORN90 3-W	xx items