

ADRIATIC VAV

Energy-saving climate beam for demand-controlled ventilation



QUICK FACTS

- Climate beam with cooling, heating and ventilation for demand-controlled indoor climate.
- Equipped with control equipment for stand-alone or connectable to BMS via Modbus
- Designed for suspended installation, either hanging or mounted directly against the ceiling.
- Complete product with integrated damper for variable air flow control 0-100%.
- Stylish design component in two optional versions
- Energy-efficient operation since the room is ventilated, heated and cooled exactly as called for by the load, neither more or less.
- Highest possible comfort with provision for individual control at a product or room level.
- Large working range in one and the same product simplifies planning.
- As an optional extra, there is a connection casing for concealing the ventilation duct and water pipes.
- Service-friendly with folding design component for easy accessibility.
- Standard colour White RAL 9003
 - 5 alternative standard colours
 - Other colours on request

Variant		Supply air			Performance	
Size (m)	Air connection Ø	Pa*	l/s	m ³ /h	Total cooling capacity [W]**	Sound level [dB(A)] ***
1.2	125	50	14	50.4	518	<20
1.2	125	50	21	75.6	596	24
1.8	125	50	10	36	539	<20
1.8	125	50	20	72	796	<20
1.8	125	50	31	111.6	934	25
2.4	125	50	14	50.4	788	<20
2.4	125	50	30	108	1101	21
2.4	125	50	44	158.4	1236	28
3.0	125	50	17	61.2	946	<20
3.0	125	50	34	122.4	1298	20
3.0	125	50	52	187.2	1467	30

*Total pressure duct (Pa)

**Air: $\Delta T_{air}=7K$, Water: $\Delta T_{mk}=8.5K$, water flow=0.05 l/s for 1.2 m and 1.8 m, water flow=0.1 l/s for 2.4 m and 3.0 m

***Including -4dB room attenuation

Contents

Technical description	3
Variants	4
Compact and intelligent unit.....	5
Factory fitted components	5
Air distribution.....	6
Control equipment.....	7
Operating modes.....	8
Functions.....	8
Room controller, LOCUS.....	9
Sensor module.....	10
SWICCT.....	11
Flow distribution.....	12
Installation	13
Connection.....	14
Water	14
Air	14
Control equipment.....	14
Technical data.....	15
Cooling.....	15
Heating.....	15
Optional extras and accessories	18
Factory-fitted optional extras and accessories.....	18
Loose accessories.....	19
Accessory kits	22
Dimensions and weight.....	23
Specification.....	24
Product.....	24
Accessories	24
Contractor demarcation	25
Specification text.....	26

Technical description

Version

- The product is a suspended climate beam with two-way air discharge and stepless air flow control, which is also equipped with functions for demand control of the indoor climate.
- The product has an attractive design and extremely low installation height that fits in well in all types of room decor.
- The ADRIATIC VAV climate beam has mounted control equipment, demand-controlled air flow and cooling and heating for the best energy efficiency and comfort.
- ADRIATIC VAV can be adapted and combined to meet comfort requirements in most projects. ADRIATIC VAV is a complete and fully flexible product with Swegon's unique slot adjustment, an adjustable air distribution pattern with the help of ADC and the option of factory-fitted accessories.
- The increased cooling capacity also enables a lower duct pressure or a higher cooling water temperature can be used, which saves energy and even improves room comfort further.
- The connection components are concealed in a simple manner by an attractive connection casing. The casing is installed after the chilled beam has been suspended and connected.

Demand-controlled indoor climate

Demand-controlled ventilation involves ventilating and conditioning the air in a room precisely to meet our needs – no more and no less. The potential for savings is substantial, especially in premises where there is considerable variation between low and high load conditions in rooms and during times when there are few or no occupants - which is the case in many premises. Offices, for example, often have a degree of occupancy below 50%!

ADRIATIC VAV combines the best of both worlds – demand-controlled ventilation with all its potential for savings combined with the power and performance of the climate beam for air conditioning the room. All this packaged in a compact unit that is easy to install.



Figure 1. ADRIATIC VAV with design component Prisma

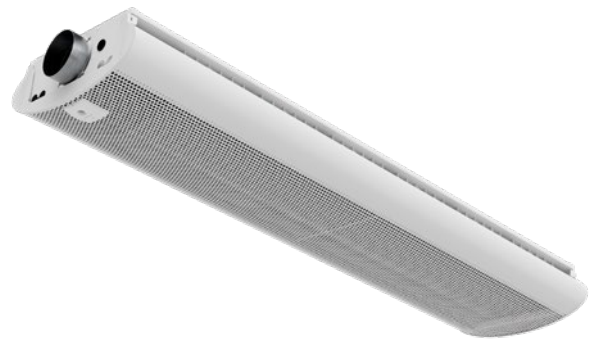

Figure 2. ADRIATIC VAV with design component Ellips

Variants

Sizes

- 1.2, 1.8, 2.4 and 3.0 m

With its high capacity, the new ADRIATIC VAV can often replace another, larger product.

Versions

- Prisma, design component with a more traditional form
- Ellips, design component with a softer, rounder form

Functions

- Cooling and ventilation
- Cooling, heating and ventilation

Installation

The ADRIATIC VAV is designed for suspended installation, either hanging or mounting directly against the ceiling. In those instances you wish to conceal the ventilation duct and water pipes, there is also a connection casing as an optional extra.

Material

The casing is made from prepainted sheet steel.

The face plate on the Prisma is made of prepainted sheet steel, while for Ellips it is made of aluminium and sheet steel.

The coil is made of copper and aluminium.

The connection casing is made of prepainted sheet steel.

Maintenance

The product does not require any maintenance/service, except for any cleaning when necessary. See the separate Instructions for Use, available on www.swegon.com.

Environment

The Building Materials Declaration is available from www.swegon.com.

Colour

The product, the connection casing and the surface mounted assembly piece are painted as standard in RAL 9003 standard colour, white, gloss ratio $30 \pm 6\%$, but can also be ordered in the following colours.

RAL 7037 Grey, gloss ratio 30-40%

RAL 9010 White, gloss ratio 30-40%

RAL 9005 Black, gloss ratio 30-40%

RAL 9006 Silver, gloss ratio 70-80%

RAL 9007 Grey, gloss ratio 70-80%

Special types

On request, the product, the connection casing and the surface mounted assembly piece can also be supplied painted in an optional colour or relief finish paint. For further details about special types, get in touch with your nearest Swegon representative.

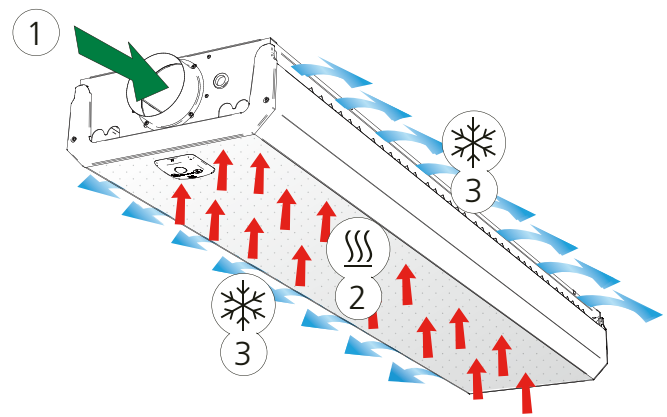

Figure 3. Cooling and supply air function

1 = Primary air

2 = Induced room air

3 = Primary air mixed with cooled room air

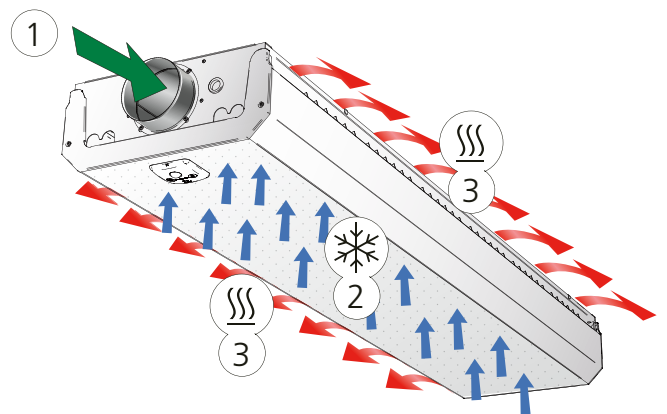

Figure 4. Heating and supply air function

1 = Primary air

2 = Induced room air

3 = Primary air mixed with heated room air



www.eurovent-certification.com

www.certiflash.com

Compact and intelligent unit

ADRIATIC VAV comes as a compact and intelligent unit, where the damper and control equipment are integrated in the product and concealed below the design cover.

The only additional connections are the power and a possible connection to a main control system.

ADRIATIC VAV is a future-proof product that can control the air flow and the temperature depending on the temperature of the air or occupancy in the room. The product can also be used to synch multiple units in a larger area by means of one becoming a Main unit that controls several other Sub-units.

The product is configured with:

- LOCUS room controller, as the configuration tool if necessary or wall-mounted
- Computer connected with RJ12 cable

ADRIATIC VAV is equipped as standard with the following components

- Controller
- Motor 0-10 V for regulation of the internal damper.

Factory fitted components as an option

- Condensation sensor CG-IV or WCD2
- Temperature sensor
- Set point selector switch that includes occupancy detector and temperature sensor (mounted in the face plate or supplied separately for wall mounting)
- CO₂ sensor. Detect Qa
- VOC Sensor
- Valves and actuator
- Hygiene design hinged coil

Loose accessory kit

There is also several accessory kits available for retrofitting if you wish to expand the functionality:

- CG-IV kit
- WCD2

Factory fitted components

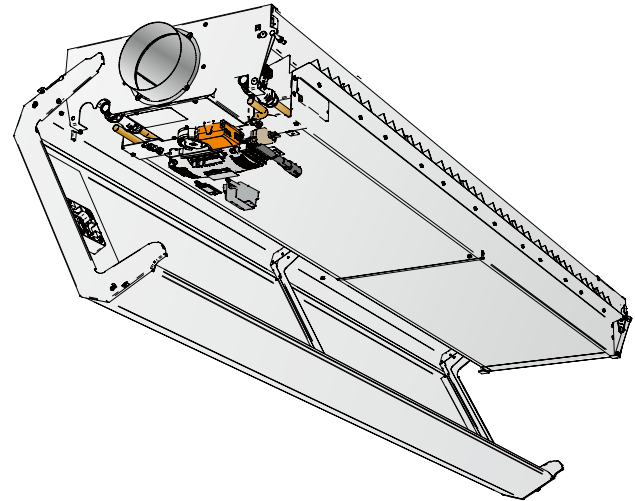

Figure 5. Factory fitted components such as controller, valves and actuators are concealed below the face plate, but are easily accessible by folding down the face plate.

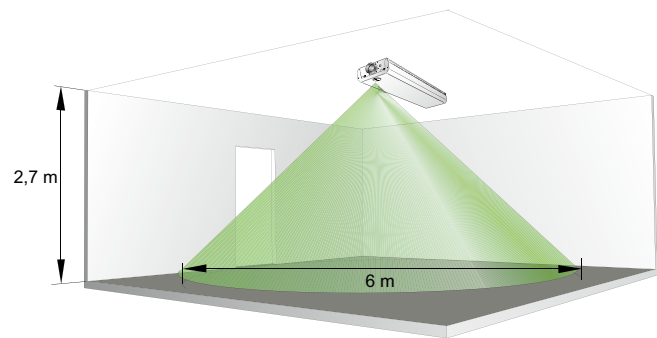

Figure 6. Detection range for use of sensor module in the face plate

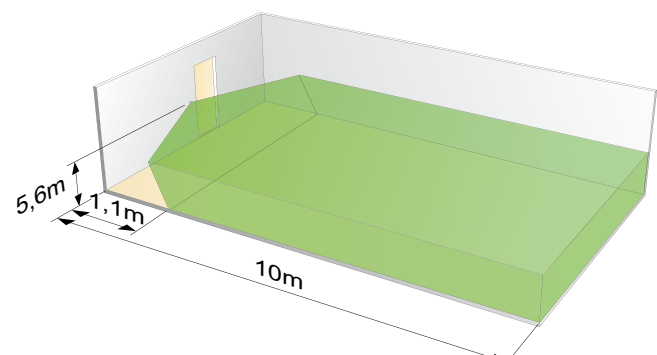

Figure 7. Detector range from wall

Air distribution

The climate beam uses supply air to operate the cooling and heating function of a central air handling unit and therefore does not include an integrated fan or other moving parts. This gives very quiet operation and minimal maintenance requirements.

The distribution air is spread from two sides of the unit, and utilises a large part of the ceiling to spread the air and ensure comfort in the occupancy zone.

Adriatic has variable k-factor setting and large air flow range. The product is a VAV variant complete with mounted control equipment for demand-controlled ventilation, but is also available as a CAV product with fixed k-factor ADRIATICd and a DCV variant WISE Adriatic. ADRIATIC VAV has variable control.

It is also possible to set an asymmetric air flow in order to adapt to various room types and refurbishments.

The integrated slot control of the air flow means that the product can retain pressure internally and at the same time supply air with the correct throw lengths, even at low flows.

Induction principle

Primary air (A) from the air handling unit provides ADRIATIC VAV with supply air via a supply air duct and builds up positive pressure in the unit's plenary.

The supply air is forced out at high speed through small slots (B). The high speed means that the surrounding air is drawn in and mixed with supply air, which generates negative pressure above the unit's integrated heat exchanger (C). Room air (D) is continuously drawn up from the room through the water-based heat exchanger where, if necessary, it is cooled or heated before it mixes with the supply air.

The mixed air is then distributed to the room via aerodynamically designed outlets. The outlets are designed to ensure that the distributed air follows the suspended ceiling by utilising the so-called Coanda effect (E). The supplied air is then mixed with additional room air, which further lowers the air velocity and lessening the temperature difference before it reaches the occupied zone.

The proportion of recirculated room air drawn through the heat exchanger is typically about 3-5 times the proportion of primary air, i.e. if 20 l/s supply air comes from the air handling unit, then approximately 60-100 l/s room air will pass through the exchanger and be tempered.

Condensation-free cooling

ADRIATIC VAV has been developed to work condensation-free and therefore requires no drainage system or filter. Normally inlet temperatures between 14-16 °C are used for the cooling water.

High comfort – today and tomorrow.

Through its control function, ADRIATIC VAV can be used in an energy-efficient manner, adapted for various needs, and consequently will be able to be used for a long time to come. Climate and comfort-smart for a long time to come.

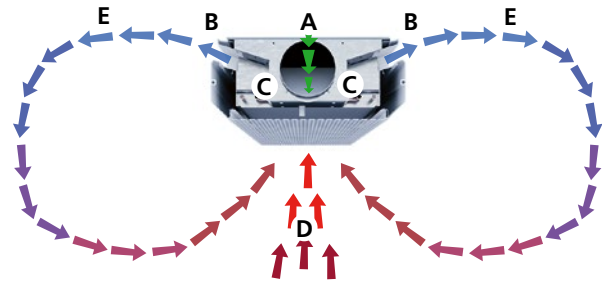

Figure 8. Induction principle in ADRIATIC VAV

Control equipment

VAV - Control equipment for demand-controlled ventilation, heating and cooling

In order to meet changing needs, with varying degrees of occupancy during the day or individual preferences, the beam needs to be regulated. The product is controlled with a VAV controller with a number of I/O, which control the product according to configured guidelines and measurement data from sensors or can easily be integrated in a BMS system via Modbus.

ADRIATIC VAV is fully equipped with actuator, controller, pressure sensor, valves and valve actuators for optimum demand control according to the actual need during the day.

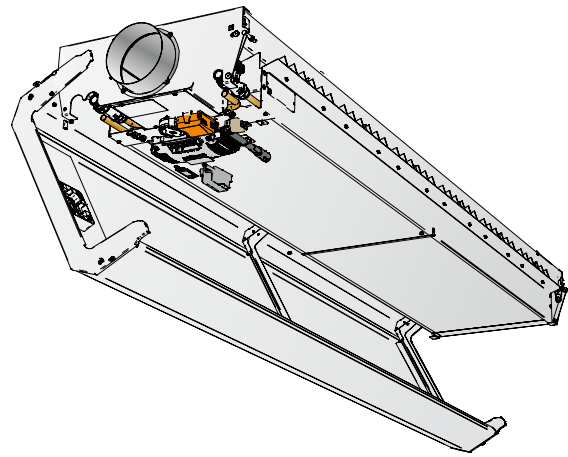

Figure 9. ADRIATIC VAV, complete with factory-fitted controller, actuator, pressure sensor and valves and valve actuators for cooling and heating water.



Figure 10. VAV controller for demand-controlled ventilation



Figure 11. Room controller LOCUS is suited for use along with VAV controller for configuration or use



Figure 12. Sensor module for used together with VAV controller for demand-controlled ventilation. Selected as a product accessory and mounted in the face plate or on the wall.

Operating mode

Depending on the status of connected sensors, the VAV controller adjusts the actuator and air supply according to various operating modes.

Occupancy mode

In the case of measured occupancy via sensors, the ventilation and temperature are controlled as required in order to meet the set values.

Unoccupancy mode

The system goes into energy-saving mode and minimises ventilation and cooling/heating, based on the sensor values.

Holiday

When Holiday mode is enabled, the system automatically switches to energy save mode exactly as in No occupancy mode, but with the possibility to permit an even greater temperature difference. Controlled from the main control system.

Standby mode

When the control system registers that a window is open the controller switches to Standby mode. When the window is closed the controller switches to Occupancy mode. When the controller is in Standby mode the room temperature is kept above 10 °C (frost protection).

Emergency mode

In the event of a fire alarm, the air damper in the extract air duct is open or closed, depending on how the control system has been set. In Emergency mode cooling and heating are switched off. Supply air is normally switched off.

Operating mode EMERG can only be handled in control systems that are connected to the main control system via Modbus RTU.

Commissioning mode

The "first open" function means that the water valves are open during installation, which simplifies filling, pressure testing and venting the water system.

The function is disabled automatically after being energised for about 6 minutes.

Summer night cooling

The function means that cold outdoor air is used to cool the room during the night to the predefined level.

The function can only be handled in control systems that are connected to the main control system via Modbus RTU.

Activating valves

The function requires regular automatic activation of the water valves to avoid them beginning to stiffen or stick. During activation, all valves connected to the regulator are open for a maximum of 6 minutes, and then closed. The valves for the cooling system are activated first, followed by those for the heating system.

Frost protection

The function means that heating operations start at 10°C to counteract the risk of damage that can otherwise occur due to freezing.

Functions

Change over

The function involves the use of only one valve actuator which should be wired to the cooling output terminal. This actuator then controls both the heating water and the cooling water, which is transported in the same pipe. An external temperature sensor should be used and this should measure on the main pipe where the water always circulates.

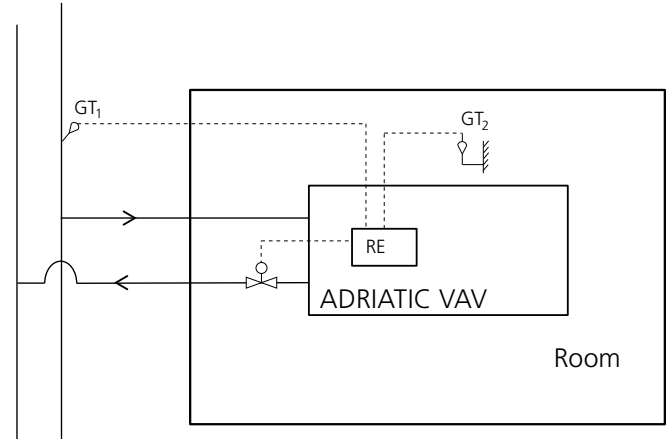

Figure 13.

- 2-pipe system with cooling water in the summer and heating water in the winter
- GT1 is placed where heating or cooling water always circulates
- Summer: If the room temperature T2 is higher than the water temperature T1, the valve opens when cooling is required.
- Winter: If the room temperature T2 is lower than the water temperature T1, the valve opens when heating is required.
- GT1 is connected to the regulator as an external temperature sensor
- In SWICCT or with LOCUS, it is possible to change the parameters so that the sensor is used for the change-over function.
- GT2 is the temperature sensor which is located in the Sensor module
- The valve actuator must be connected to the regulator's cooling output.

SWICCT:

External temperature sensor use

Change over temperature	▼
Not used	
Room temperature	
Change over temperature	
Temperature (read only)	
Window contact NO	
Window contact NC	

Room controller, LOCUS

Main menu and explanation of symbols

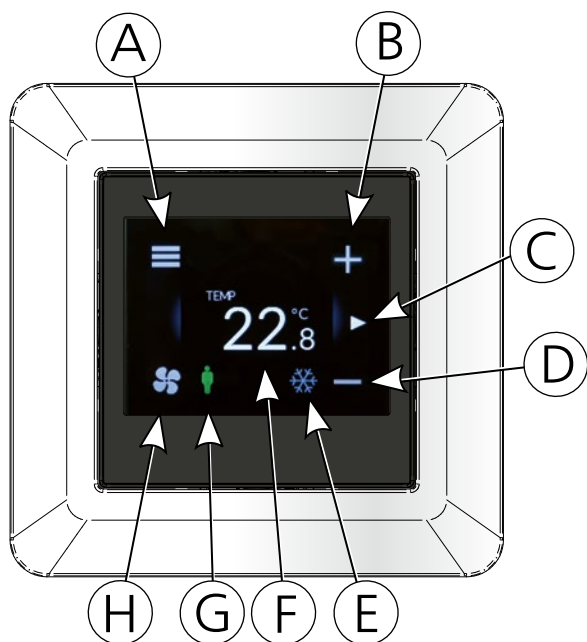

- A. menu
- B. increase
- C. swipe left to go to the next page
- D. decrease
- E. symbol showing ongoing cooling or heating
- F. shows programmed setpoint or measured temperature
- G. shows occupancy in the room
- H. press to activate boost flow

Technical data

Display	Capacitive touch TFT Display QVGA 2.3"
Screen resolution	320x240
Communication	Modbus RTU via RS-485
Temperature sensor	Internal 10K NTC sensor
Operating temperature	+5 ... +40°C
Degree of protection	IP20
Dimensions	88 x 88 x 35 mm
Colour	Optional white or black frame
Operating voltage	12-40 VDC
Current requirement	0.5 W

Connection

LOCUS	Connection	Description
VDD	RJ12	12-40 VDC power supply
A+	RJ12	RS-485 bus connection
B-	RJ12	RS-485 bus connection
GND	RJ12	Earth for 12-40 VDC power supply
LOCUS	RJ12	Connection on the URC1 controller
Memory card slot		The user panel's software can be updated via a Micro SD card

Standards and directives

The following standards have been observed:

EC Directive:	93/68/EEC
Low Voltage Directive:	2014/35/EU
Machinery Directive:	2006/42/EEC
EMC Directive:	2014/30/EU
RoHS Directive:	2002/95/EC
Vibrations:	EN-60721-3-3

Description of display

Display	Description	Explanation
	Display in standby mode	Activated with a click
	Active main menu	Click on the + or - signs to increase/decrease the setpoint temperature
	Activated boost mode	
	Swipe left for next display page	Shows input values from connected sensors
	Swipe right to go back to the main menu	

For more detailed information about LOCUS room controller. See the following documentation at www.swegon.com

LOCUS Product datasheet

LOCUS Instructions for Use (IOM)

Sensor module

The sensor module consists of an occupancy sensor and a temperature sensor in the same unit.

On delivery, the sensor module is connected and mounted on the end. It is simply secured to the face plate on ADRIATIC VAV. It can also be ordered as an accessory for installation on the wall, in which case it is either recess mounted in a standard junction box or surface mounted.

The pushbuttons on the sensor module allow you to adjust the temperature in the room, put the ADRIATIC VAV in commissioning mode and read the alarm list.

In the event of a fault, the relevant alarm is indicated in the form of flashing LEDs that is translated with the help of an alarm list.

The sensor module is connected to the controller with the help of an RJ12 cable.

The floor surface that the presence sensor covers is approximately 24 m² when installed at a height of 2.7 m above the floor and parallel to it.

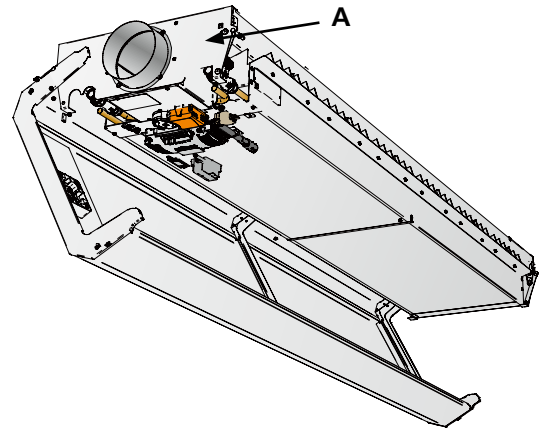

Figure 16. Placement of the sensor module on delivery (A).

Temperature adjustment

Reduce the temperature by pressing the left-hand button



Increase the temperature by pressing the right-hand button

Each LED corresponds to an increase or decrease of the set point by one degree. Base setting of temperatures is made in SWICCT or SuperWISE

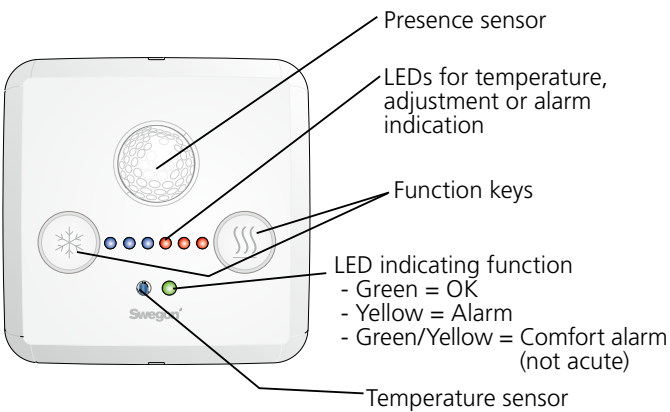

Figure 14. Sensor module seen from the front

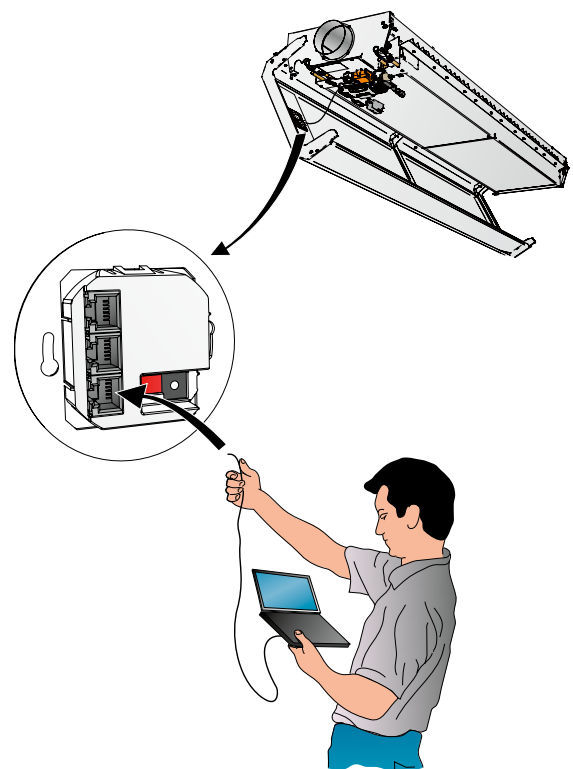

Figure 17. With the help of CABLE CONVERTER USB-RJ12 (RS485), you can easily connect a PC or LOCUS room controller to make e.g. software settings. The connection can either be made on the rear of the sensor module as illustrated, or directly on the controller. How to do this is described in the SWICCT manual.

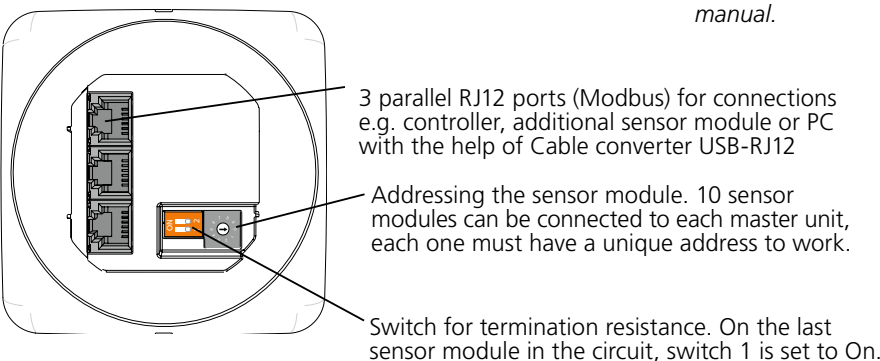

Figure 15. Sensor module seen from the back

SWICCT

SWICCT (SWegon Indoor Climate Configuration Tool) is the software that makes it easy to make settings in the controller. (To make settings requires the cable "CABLE CONV. USB RJ-12", and the installation of this, see the SWICCT manual)
Here it is possible to make all essential settings for the Product, for example;

- Base settings for temperature
- Use of external sensors, e.g. for air quality
- Air flows
- Commissioning

The screenshot displays the SWICCT v1.22 software interface with the following sections:

- Temperature setpoint settings:** Cooling setpoint OCC (2350 °C * 100), Heating setpoint OCC (2250 °C * 100), Cooling setpoint NoOCC (2400 °C * 100), Heating setpoint NoOCC (2100 °C * 100), Cooling setpoint Holiday (2300 °C * 100), Heating setpoint Holiday (2400 °C * 100), Cooling setpoint SNC (2400 °C * 100), Heating setpoint SNC (2100 °C * 100).
- Regulator settings:** P-band Heating (200 °C * 100), P-Band Cooling (200 °C * 100), Hime Heating (10 min), I-Time Cooling (10 min), P-Band airflow (1000 l/s * 10), Hime airflow (120 s).
- CO2/VOC:** VOC use (Auto), CO2/VOC min set value (850 ppm), CO2/VOC max set value (1050 ppm), Input 3 usage (CO2 2-10V), CO2/Volt (sensor) (200 ppm).
- Controller settings:** Ventilation boost delay (72 h), Ventilation boost time (1 min), Temperature offset timer (8 h), Occupancy on delay (10 s), Occupancy off delay (1024 s), Occupancy type (Auto), Two step cooling delay (10 min), Air cooling sequence (Air - Water), Slave air function (Variable), Heat type (Radiator), Cold draft protection level (0 % * 100), Cold draft protection stop (0 % * 100), Cold draft protection UnOcc (checkbox), Actuator period time (600 s), Continuous airflow type (Linear).
- Temperature settings:** Room temperature sensor use (Mean value of sensor module(s)), Input 1 usage (External temp) (Window contact NO), ChOv-4 Dead Zone low limit (550 V * 100), ChOV-4 Dead Zone high limit (650 V * 100).
- Airflow settings:** Kfactor short side (1+3) (0 k * 100), Kfactor long side (2+4) (580 k * 100), Zero cal. pressure sensor (checkbox), Airflow setpoint HOLIDAY (100 l/s * 10), Airflow setpoint UNOCC (90 l/s * 10), Airflow setpoint OCC (200 l/s * 10), Airflow setpoint MAX (450 l/s * 10), Min cooling Pressure (50 dPa), ADAPT EA analog min (90 l/s * 10), ADAPT EA analog max (460 l/s * 10), ADAPT EA offset (0 % * 100).
- Commissioning:** Air (Off selected), Water (Off selected), Min unoccupied, Min occupied, Max, Min holiday, Valve first open function (checkbox), STOP water actuators (checkbox).
- Buttons:** Check slave bus, Write settings to file, Read current values, Exit.
- Device tree:** 1 URC1.
- Status bar:** Selected controller: URC1 with Modbus ID 1.

SWICCT is available for download from www.swegon.se, both the software and a separate manual.

Flow distribution

symmetric and asymmetric setting

For symmetric and asymmetric setting, see ADRIATIC VAV installation instructions.

ADC

The climate beam is supplied with the ADC air deflector. ADC stands for Anti Draught Control, which enables you to set the diffusion pattern of the air being distributed to avoid risk of draught. A number of ADC sections with four air deflectors per section are arranged on each long side. Each section is adjustable from a straight setting to 40° air deflection to the right or left in increments of 10°. This provides great flexibility and can be easily adjusted without having to affect the system as a whole.

The ADC does not affect the noise level or static pressure at all. The water capacity is reduced by 5-10% if the ADC is adjusted to “fan-shape”.

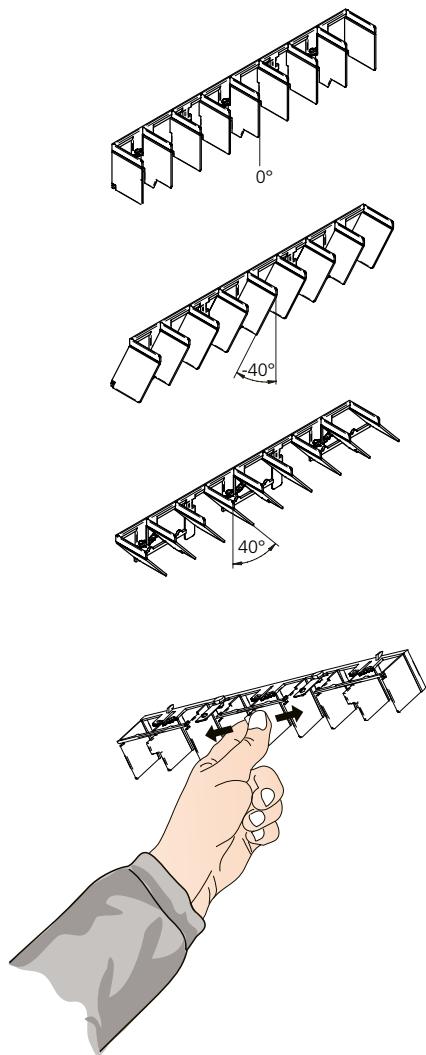

Figure 18. ADC, setting range from -40° to +40° in increments of 10°

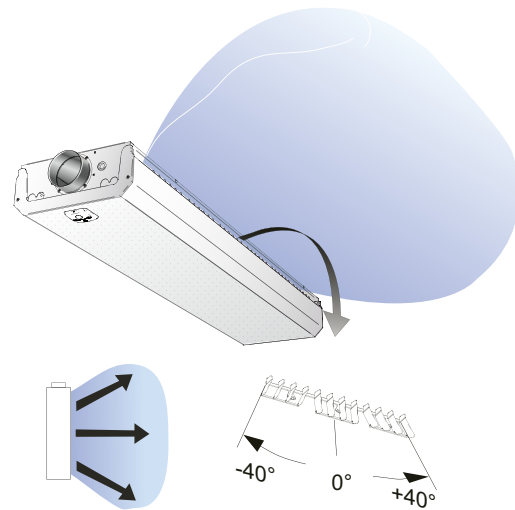

Figure 19. Possible settings for the ADC, Fan-shape

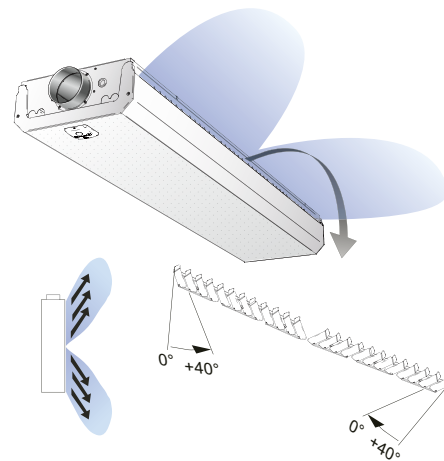

Figure 20. Possible settings for the ADC, V-shape

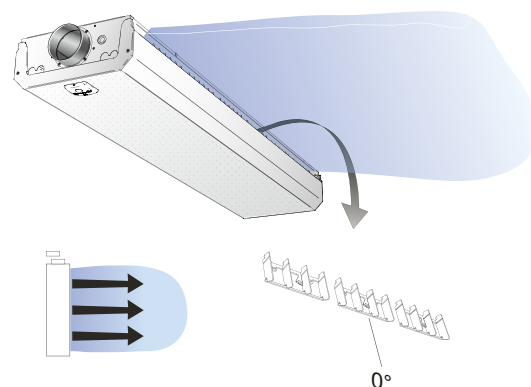

Figure 21. Setting options ADC, Straight setting

Installation

Suspension:

The new Adriatic is equipped with threaded blind rivets at each corner for simple installation with threaded rods in the ceiling.

The units are delivered without mounting parts. If assembly fittings are required, these can be ordered separately.

Installation accessories:

SYST MS-M8 is available for suspended installation.

ADRIATIC d-T-MD-4S is available for installation directly against the ceiling

Folding of the design component

The unit is fitted with a pushbutton at either end of one long side, for simple folding of the design component and access to e.g. control equipment. When folding, one long side is opened and the design component then hangs from the opposite long side.

Connection casing

The connection casings are available in several lengths and several selectable colours, and are ordered separately (ceiling brackets included).

Connection to wall

Connection casing that is mounted in the extended section of the climate beam a connected to a wall, designed for concealing pipe and duct connections.

Connection to ceiling

Connection casing with end connection panel is mounted in the extended section of the climate beam and connected to a ceiling, designed for concealing pipe and duct connections.

Note: Min. 3xØ before elbow.

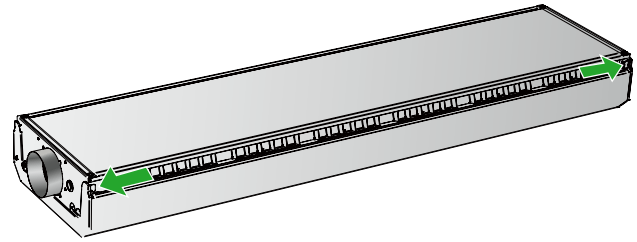

Figure 22. ADRIATIC Prisma with pushbutton for simple folding of the design component.

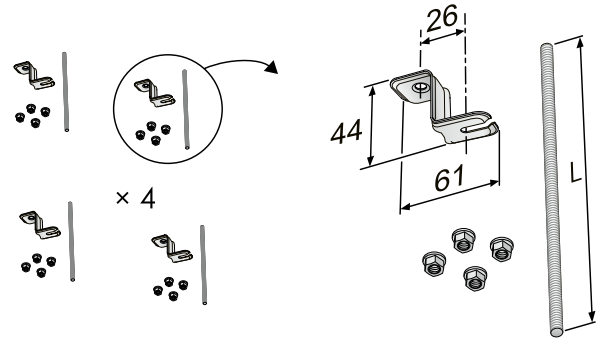

Figure 23. Assembly fitting SYST MS M8-1, ceiling mount and threaded rod

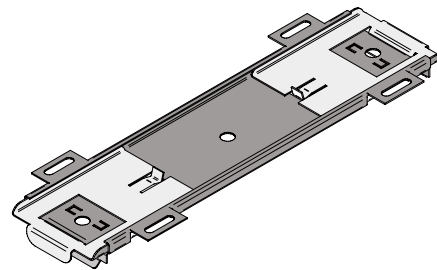

Figure 24. Assembly fitting ADRIATIC d-T-MD-4S, for direct ceiling installation.

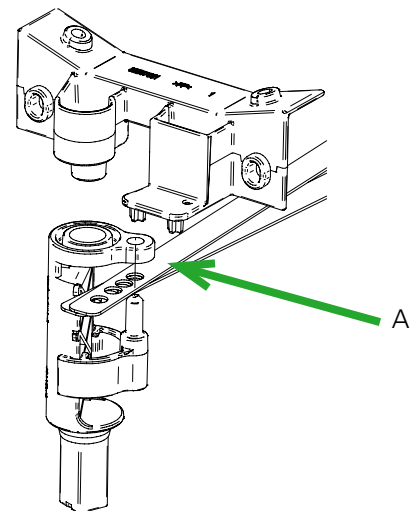

Figure 25. It is also possible to e.g. lock one side. Using the rods (A), the slots are controlled on either side of the beam.

Connection Water

Connection dimensions

Unit	Cooling and Heating
(m)	Supply and return
1.2, 1.8, 2.4, 3.0	plain pipe ends (Cu) Ø 12 x 1.0 mm

Alternative to factory-fitted valves

Unit	Cooling and Heating
(m)	Return
1.2, 1.8, 2.4, 3.0	DN15 male thread

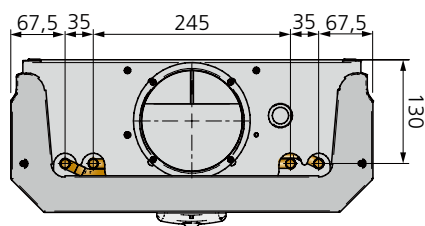

Figure 26. Dimensions ADRIATIC VAV Prisma, end view water connection

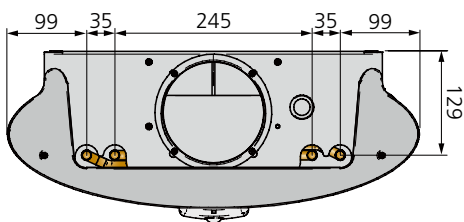

Figure 27. Dimensions ADRIATIC VAV Ellips, end view water connection

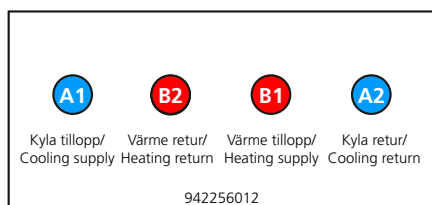

Figure 28. Water connection

- A1 = Supply cooling water Ø12x1.0 mm (Cu)
- A2 = Return cooling water Ø12x1.0 mm (Cu)
- B1 = Supply heating water Ø12x1.0 mm (Cu)
- B2 = Return heating water Ø12x1.0 mm (Cu)

Connecting water

The water pipes are placed on the same side as the air connection on the product's short side.

Connect the water pipes using push-on couplings or compression ring couplings when the product is ordered without valves. Note that compression ring couplings require support sleeves inside the pipes.

Do not use solder couplings to connect the water pipes. High temperatures can damage the unit's existing soldered joints.

Flexible connecting hoses for water are available for flat-end pipes and valves, and can be ordered separately.

Water quality

Swegon recommends water quality according to VDI 2035-2 for both the heating and cooling systems. In order to maintain the oxygen content in the water below the levels (<0.1 mg/l) prescribed in VDI 2035-2, it is recommended to install a vacuum degasser, particularly in the cooling system where it's more challenging to dissolve gas. It is also important that the pre-pressure in the expansion vessel is dimensioned according to EN-12828 for both the heating and cooling systems and that regular checks are made of the pre-pressure. The cooling and heating systems must be designed to prevent oxygen from entering the system, this is particularly important to consider when selecting flex hose, pipes and expansion vessels.

When the system is filled with fresh water, it has an oxygen content of approximately 8 mg/l, however, this oxygen is consumed quickly through corrosion processes and within a few days the oxygen in the water should be consumed. Nevertheless, it is important to avoid filling the system with fresh water unnecessarily.

Automatic deaerators are often installed to facilitate filling of the system. It is recommended that the automatic deaerators are turned off once the system has been fully vented to avoid these drawing in air in the system if the pre-pressure in the expansion vessel should drop.

Air

Unit (m)	Air connection, diameter Ø
1.2, 1.8, 2.4, 3.0	125

To connect the air

ADRIATIC VAV comes with open air connection on one short side. The spigot must be connected to the primary air duct.

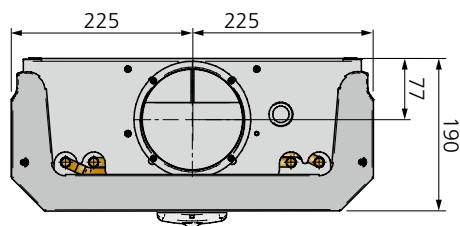

Figure 29. Dimensions ADRIATIC VAV Prisma, end view air connection

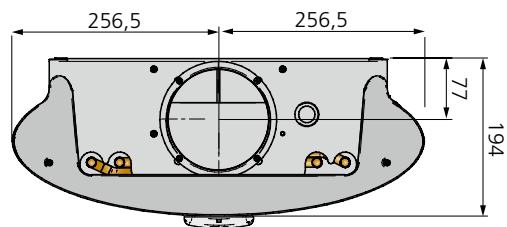

Figure 30. Dimensions ADRIATIC VAV Ellips, end view air connection

Control equipment

Factory mounted control equipment is supplied connected to the controller. Any other control equipment is connected in to the controller according to the wiring diagram in the enclosed Instructions for Use.

Technical data

The following tables are only examples. For a precise calculation of the product, use RUD or SPC, which can be obtained from our website. www.swegon.com

Key figures

Air flow range	min.	max.	
	0	98	l/s
	0	353	m ³ /h
Pressure range	min.	max.	
	20	150	Pa
Cooling capacity, total: *	Up to 3620 W		
* $\Delta t_{air}=10K, \Delta t_{mk}=12K$			
Heating capacity, water: *	Up to 6833 W		
*At $\Delta t_{mk} = 30K, \text{water flow}=0.08 \text{ l/s}, \text{changeover system}$			

Designations

ΔT_m :	Temperature difference [$t_r - t_m$] K
t_r :	Room temperature
t_m :	Average temperature of the water in the beam
ΔT :	Temperature difference between supply - return K
ΔT_{mk} :	Temperature difference, cooling
ΔT_{mv} :	Temperature difference, heating

Supplementary index: $v = \text{heating}, k = \text{cooling}, l = \text{air}, i = \text{commissioning}$

Cooling

Cooling capacities are measured in accordance with EN 15116.

Note: The total cooling capacity is the sum of the airborne and waterborne cooling capacities.

ADRIATIC VAV is always supplied with cooling/heating, even if only cooling is required.

Heating

A beam that also has integrated heating is good, as this is an energy-efficient form of heating. It is also a single system, rather than needing to add another system, such as radiators.

The heat is conducted along the ceiling which, in order to work properly, requires a low supply flow temperature and a certain impulse. A temperature gradient of 3 K is normally obtained between floor and ceiling.

Recommended limit values

Pressure levels

Coil working pressure, max.	1600 kPa *
Coil test pressure, max.	2400 kPa *

*Applies without valves or other extra equipment mounted on the coil

Commissioning pressure

Recommended lowest commissioning pressure, cooling	Air flow (l/s)	Commissioning pressure (Pa)
	<10	50
	10-25	30
	>25	20

Water flow

Min. water flow ensures evacuation of any air pockets in the coil.

Size	Cooling water, min. (l/s)	Heating water, min. (l/s)
1.2, 1.8	0.025	0.015
2.4, 3.0	0.05	0.015

The recommended max. water flow ensures that the pressure drop in the coil is not greater than max. 20 kPa

Size	Cooling water, max. (l/s)	Heating water, max. (l/s)
1.2, 1.8	0.1	0.11
2.4	0.14	0.11
3.0	0.2	0.11

Supply flow temperature

Cooling water, min.	**
Heating water, max.	60 °C

** Cooling water must always be kept at a level that ensures that no condensation is formed.

Recommendations for excess heat operation

Max. permissible supply flow temperature:	60°C
Min. permissible heating water flow:	0.013 l/s
Nozzle pressure, p_i :	>30 Pa

Table 1 – data – cooling. * Dimensioning guide for Adriatic d at total pressure 30 Pa

Unit	Air flow		Sound level	Cooling capacity of primary air at ΔT_1 (K)				Cooling capacity, water at ΔT_{mk} (K)					Pressure drop constant, air
	l/s	m3/h		6	8	10	12	6	7	8	9	10	
m													cmpl
1.2	11	40	<20	79	106	132	158	223	262	301	340	379	2.02
1.2	16	58	<20	115	154	192	230	243	283	323	363	404	2.96
1.8	16	58	<20	115	154	192	230	353	416	474	537	595	2.96
1.8	24	86	<20	173	230	288	346	388	455	516	582	643	4.50
2.4	11	40	<20	79	106	132	158	363	424	485	546	602	2.02
2.4	23	83	<20	166	221	276	331	487	567	647	727	806	4.31
2.4	34	122	21	245	326	408	490	503	586	669	752	834	6.57
3.0	13	47	<20	94	125	156	187	426	497	568	638	702	2.39
3.0	27	97	<20	194	259	324	389	580	673	767	860	954	5.10
3.0	40	144	23	288	384	480	576	594	691	787	892	987	7.91

Table 2 – data – cooling. Dimensioning guide for Adriatic d at total pressure 50 Pa

Unit	Air flow		Sound level	Cooling capacity of primary air at ΔT_1 (K)				Cooling capacity, water at ΔT_{mk} (K)					Pressure drop constant, air
	l/s	m3/h		6	8	10	12	6	7	8	9	10	
m													cmpl
1.2	14	50	<20	101	134	168	202	280	327	374	422	469	1.99
1.2	21	76	24	151	202	252	302	295	344	393	447	496	3.01
1.8	10	36	<20	72	96	120	144	320	373	426	479	537	1.42
1.8	20	72	<20	144	192	240	288	438	514	590	666	743	2.86
1.8	31	112	25	223	298	372	446	472	553	634	714	795	4.50
2.4	14	50	<20	101	134	168	202	477	556	627	706	784	1.99
2.4	30	108	21	216	288	360	432	601	698	805	902	999	4.35
2.4	44	158	28	317	422	528	634	607	709	820	923	1025	6.59
3.0	17	61	<20	122	163	204	245	569	661	753	846	938	2.42
3.0	34	122	20	245	326	408	490	722	836	950	1075	1189	4.97
3.0	52	187	30	374	499	624	749	729	847	976	1095	1214	7.98

Table 3 – Data – Cooling. Dimensioning guide for Adriatic d at total pressure 70 Pa

Unit	Air flow		Sound level	Cooling capacity of primary air at ΔT_1 (K)				Cooling capacity, water at ΔT_{mk} (K)					Pressure drop constant, air
	l/s	m3/h		6	8	10	12	6	7	8	9	10	
m													cmpl
1.2	16	58	<20	115	154	192	230	308	365	417	469	521	1.92
1.2	24	86	28	173	230	288	346	329	384	439	499	554	2.90
1.8	12	43	<20	86	115	144	173	374	441	502	569	631	1.44
1.8	24	86	21	173	230	288	346	501	586	672	757	843	2.90
1.8	36	130	30	259	346	432	518	532	621	710	800	890	4.42
2.4	17	61	<20	122	163	204	245	560	651	742	834	925	2.04
2.4	35	126	25	252	336	420	504	677	785	904	1012	1121	4.29
2.4	52	187	33	374	499	624	749	679	793	917	1032	1157	6.58
3.0	20	72	<20	144	192	240	288	657	762	868	983	1088	2.41
3.0	40	144	25	288	384	480	576	813	940	1079	1207	1346	4.94
3.0	61	220	35	439	586	732	878	815	947	1091	1236	1369	7.90

Water flow=0.05 l/s for 1.2 m and 1.8 m, water flow=0.1 l/s for 2.4 m and 3.0m, temperature inlet flow +14°C.
The specified sound level applies to straight connection without damper or with fully open damper. Room attenuation = 4 dB.

Table 4 – data – heating. Dimensioning guide for Adriatic d at 30 Pa

Unit	Air flow		Sound level	Heating capacity, water at ΔT_{mv} (K)					Pressure drop constant, air
	l/s	m ³ /h		15	20	25	30	35	
m			dB(A)						cmpl
1.2	11	40	<20	263	367	473	584	697	2.02
1.2	16	58	<20	284	394	509	628	749	2.96
1.8	16	58	<20	422	587	759	935	1118	2.96
1.8	24	86	<20	456	634	821	1009	1205	4.50
2.4	11	40	<20	476	658	842	1033	1222	2.02
2.4	23	83	<20	564	783	1004	1229	1462	4.31
2.4	34	122	21	619	850	1091	1337	1586	6.57
3.0	13	47	<20	572	787	1009	1234	1467	2.39
3.0	27	97	<20	672	928	1192	1466	1744	5.10
3.0	40	144	23	739	1014	1302	1594	1889	7.91

Table 5 – data – heating. Dimensioning guide for Adriatic d at 50 Pa

Unit	Air flow		Sound level	Heating capacity, water at ΔT_{mv} (K)					Pressure drop constant, air
	l/s	m ³ /h		15	20	25	30	35	
m			dB(A)						cmpl
1.2	14	50	<20	284	394	509	628	749	1.99
1.2	21	76	24	326	453	584	719	856	3.01
1.8	10	36	<20	399	550	709	871	1036	1.42
1.8	20	72	<20	483	669	866	1064	1268	2.86
1.8	31	112	25	522	727	939	1160	1381	4.50
2.4	14	50	<20	551	759	973	1191	1416	1.99
2.4	30	108	21	660	909	1166	1426	1690	4.35
2.4	44	158	28	717	990	1265	1551	1839	6.59
3.0	17	61	<20	665	917	1175	1438	1709	2.42
3.0	34	122	20	779	1076	1380	1690	2010	4.97
3.0	52	187	30	855	1181	1514	1853	2195	7.98

Table 6 – data – heating. Dimensioning guide for Adriatic d at 70 Pa

Unit	Air flow		Sound level	Heating capacity, water at ΔT_{mv} (K)					Pressure drop constant, air
	l/s	m ³ /h		15	20	25	30	35	
m			dB(A)						cmpl
1.2	16	58	<20	322	447	576	709	845	1.92
1.2	24	86	28	352	491	632	779	927	2.90
1.8	12	43	<20	435	602	774	954	1132	1.44
1.8	24	86	21	526	728	940	1162	1383	2.90
1.8	36	130	30	570	790	1018	1256	1497	4.42
2.4	17	61	<20	609	836	1073	1310	1554	2.04
2.4	35	126	25	716	989	1264	1550	1838	4.29
2.4	52	187	33	784	1079	1382	1689	2005	6.58
3.0	20	72	<20	723	1000	1284	1573	1860	2.41
3.0	40	144	25	847	1172	1505	1845	2187	4.94
3.0	61	220	35	934	1290	1650	2021	2395	7.90

Water flow=0.05 l/s, room temperature 20°C

The specified sound level applies to straight connection without damper or with fully open damper. Room attenuation = 4 dB

Optional extras and accessories

Factory-fitted optional extras and accessories

Valve, cooling & heating

Factory fitted valves for cooling and heating.

Length	Function	Type	Dim.	K_v (m ³ /h)
1.2 - 3.0	Cooling/ heating	VDN215	DN15 (1/2")	0.07-0.89

The valve is mounted on the product and preset fully open.

For more information about the valve, see the separate product data sheet on www.swegon.com.



Actuator cooling & heating, ACTUATORc 24 V NC

Factory fitted valve actuators for cooling and heating.
24 V AC/DC, NC (Normally Closed).

For more information about the actuator, see the separate product data sheet on www.swegon.com.



Transformer, Power Adapt 20 VA

Transformer for the voltage supply of the product.
Protective transformer with plug type F.
Input voltage 230 V 50-60 Hz

Output voltage 24 V AC
Power 20 VA
Double insulation
Enclosure IP33



Condensation sensor WCD2

The detector operates at the dew point temperature rather than a fixed relative humidity value.

The dew-point is calculated from a temperature compensated RH element and an extremely accurate sensor element that is bound to the metal plate on the detector.

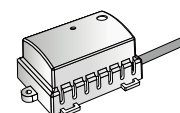

Condensation sensor, CG IV

The condensation sensor is supplied fitted and connected from the factory. The actual sensor element consists of a circuit board with gold plated conductive paths that react when condensation occurs between these. When condensation arises, the cooling valve closes the incoming water flow to the product. When the condensation on the conductive paths has been wiped off, the cooling valve is permitted to open again.

The sensor is positioned on the coil fins by the cooling supply.

For more information about the condensation sensor, see the separate product data sheet on www.swegon.com.

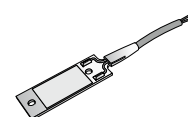

Temperature sensor, T-TG-1

External temperature sensor. Used for example if the room temperature must be measured elsewhere than at the sensor module, or to measure the temperature of the main pipe in change-over systems.

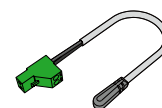

Sensor module

Rectangular sensor module with temperature and presence sensors.

Selected for mounting in either the face plate or for wall mounting.

Sensor module for wall mounting supplied loose. Mounting frame is then supplied for the most common junction boxes and a spacer frame for surface mounting.



Co₂ sensor. Detect Qa

Analogue carbon dioxide sensor that is mounted concealed, above the face plate.

See separate product datasheet at www.swegon.com.



VOC sensor Detect VOC

Modbus connected air quality sensor that is mounted concealed above the face plate.



Loose accessories

Transformer, Power ADAPT 20 VA (ARV)

Input voltage 230 V, 50-60 Hz, Output voltage 24 V AC
Power 20 VA, Enclosure IP33

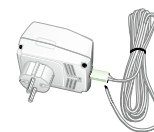

Transformer, SYST TS-1

Double-insulated protective transformer 230 V, AC/24 V AC
Input voltage 230 V, 50-60 Hz, Output voltage 24 V AC,
Power 20 VA, Enclosure IP33

For more information, see the separate product data sheet on www.swegon.com.

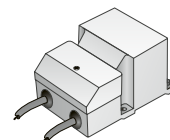

Temperature sensor, T-TG-1

External temperature sensor. Used for example if the room temperature must be measured elsewhere than at the sensor module, or to measure the temperature of the main pipe in change-over systems.

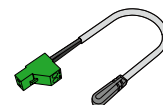

Six-way valve, CCO

Compact Change Over, for maximum utilisation of the coil and thus high cooling and heating capacity.

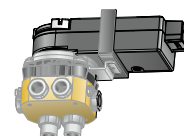

Valve (Straight)

Valves for cooling and heating.

The valve is mounted on the product and is preset to fully open.

Length	Function	Type	Dim.	K_v (m ³ /h)
1.2 - 3.0	Cooling/heating	VDN215	DN15 (1/2")	0.07-0.89
2.4, 3.0	Cooling/heating	VDN220	DN20 (3/4")	0.22-1.41

Note: VDN220 has to be installed outside the product

For more information about the valve, see the separate product data sheet on www.swegon.com.



Valve actuator, cooling & heating, ACTUATORc 24 V NC

Valve actuators for cooling and heating.

24V AC/DC, NC (Normally Closed).

For more information about the actuator, see the separate product data sheet on www.swegon.com.



Card switch, SYST SENSO II

Key card holder for hotel rooms.



Room controller, LOCUS

Setpoint selector switch with built-in temperature sensor, designed for Swegon's products with a VAV controller (URC1). It has a digital, colour touch-display, where you can regulate the indoor climate by increasing or decreasing the setpoint temperature. You can also see air flows, pressure, VOC, CO₂ and alarms.



Sensor module, external

Rectangular sensor module with temperature and occupancy sensors for wall mounting.

Always supplied with both a mounting frame for the most common junction boxes and a spacer frame for surface mounting.



Cable, SYST KABEL RJ12 6-LED.

Cable for the connection of an external sensor module to the controller or between sensor modules. Available in different standard lengths.



Cable, CABLE CONVERTER USB-RJ12 (RS485)

Cable with integrated modem to connect a PC to the controller. Needed to run e.g. SWICCT or ModbusPoll.



Cable adapter, ADAPTER RJ12-WIRE

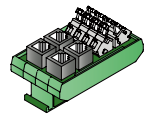

LINK Wise

Network cable for Modbus communication in the WISE system. The cable conforms to the EIA 485 standard. Shielded four conductor AWG 24, external diameter Ø 9.6 mm, Grey PVC. The cable is only supplied in reels of 500 m.



Co₂ sensor. Detect Qa

Analogue carbon dioxide sensor that is mounted concealed, above the face plate. See separate product datasheet at www.swegon.com.

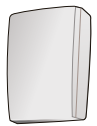

VOC sensor Detect VOC

Modbus connected air quality sensor that is mounted concealed above the face plate.

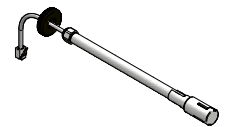

Assembly fitting, SYST MS M8

For installation use the assembly fitting containing threaded rods, ceiling brackets and nuts to all four mounting brackets.



Assembly piece, ADRIATIC d-T-MD-4S

Special assembly piece for installation directly against the ceiling. Available in 2-packs and 3-packs.

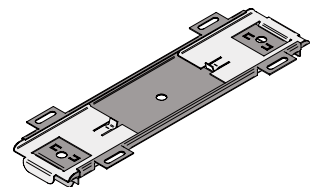

Condensation sensor WCD2

The detector operates at the dew point temperature rather than a fixed relative humidity value. The dew-point is calculated from a temperature compensated RH element and an extremely accurate sensor element that is bound to the metal plate on the detector.

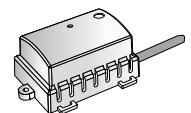

Condensation sensor, CG IV

The condensation sensor's sensor element consists of a circuit board with gold plated conductive paths that react when condensation occurs between these. When condensation arises, the cooling valve closes the incoming water flow to the product. When the condensation on the conductive paths has been wiped off, the cooling valve is permitted to open again.

Sensor is positioned on the coil fins by the cooling supply.

For more information about the condensation sensor, see the separate product data sheet on www.swegon.com.

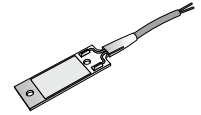

Connection casing, connection to wall, ADRIATIC d KA

Connection casing in two parts to be mounted in the extended section of the climate beam and beyond to a wall designed for concealing pipe and duct connections.

The casing is available in eleven different length ranges.

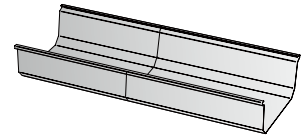

Connection casing, connection to ceiling, ADRIATIC d KA-G

Connection casing with end connection panel designed for concealing pipe and duct connections when connecting to a ceiling.

The casing is available in six different lengths.

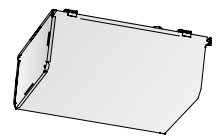

Flexible connection hoses, SYST FH

Flexible hoses are available with quick-fit, push-on couplings as well as clamping ring couplings for quick and simply connection. The hoses are also available in various lengths. Note that compression ring couplings require support sleeves inside the pipes.

F1 = Clamping ring couplings at both ends.

F20 = Push-on couplings at both ends.

F30 = Push-on coupling at one end and union nut G20ID at the other end.

F4/F5 = Clamping ring coupling at one end and union nut with flat seal at the other end.

F40 = Push-on coupling at one end, union nut 90° at the other end.

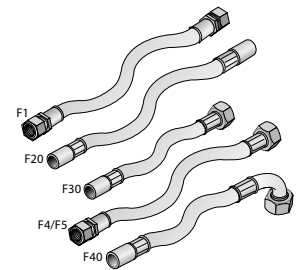

Venting nipple, SYST AR-12

A venting nipple is available as a complement to the flexible hoses with push-on couplings. The venting nipple fits directly in the push-on hose coupling and can be fitted in an instant.

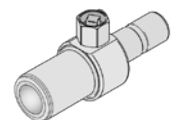

Connection piece, air – insertion joint, SYST AD1

SYST AD1 is used as a joint between ADRIATIC VAV and the duct system.

Dimension: Ø125 mm.



Connection piece, air, SYST CA

90° duct bend

Dimension: Ø125 mm.



Accessory kits

CG-IV-KIT

Condensation sensor CG-IV and assembly parts for retrofitting.

Condensation sensor's sensor element consists of a circuit board with gold plated conductive paths that react when condensation occurs between these. When condensation arises, the cooling valve closes the incoming water flow to the product. When the condensation on the conductive paths has been wiped off, the cooling valve opens again. The sensor is positioned on the coil fins by the cooling supply.

For more information about the condensation sensor, see the separate product data sheet and installation instructions on www.swegon.com.

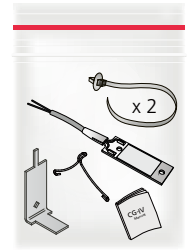

WCD2-KIT

Condensation sensor WCD2 and assembly parts for retrofitting.

The detector operates at the dew point temperature rather than a fixed relative humidity value.

The dew-point is calculated from a temperature compensated RH element and an extremely accurate sensor element that is bound to the metal plate on the detector.

For more information about the condensation sensor, see the separate product data sheet and installation instructions on www.swegon.com.



Dimensions and weight

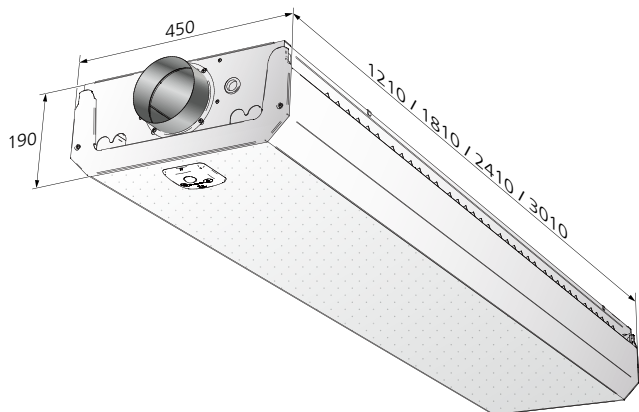

Figure 31. Dimensions - ADRIATIC VAV Prisma
With a sensor module in the face plate, the height measurement increases by 12 mm.

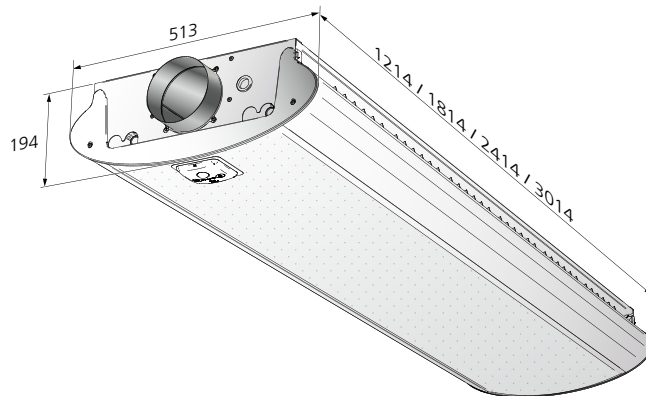

Figure 32. Dimensions - ADRIATIC VAV Ellips
With a sensor module in the face plate, the height measurement increases by 12 mm.

Installation

The c-c spacing is the same for ADRIATIC VAV with design modules Prisma and Ellips. Prisma is shown in the examples to the right.

Length (m)	Suspended installation		Surface mounted installation	
	c-c (mm)	c-c (mm)	c-c (mm)	c-c (mm)
	Short side	Long side	Short side	Long side *
1.2	392	1173	280	250
1.8	392	1773	280	250
2.4	392	2373	280	250
3.0	392	2973	280	250

* Max. distance from the end of the product.

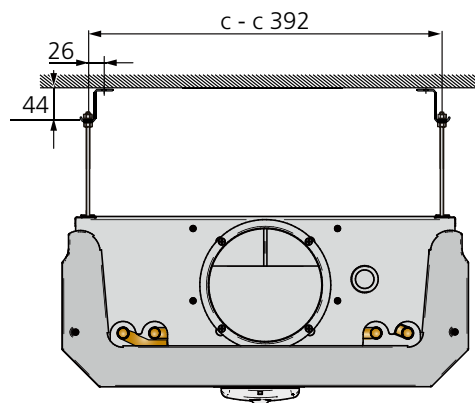

Figure 33. Installation - suspended installation with assembly fitting SYST MS-M8.

Weight - ADRIATIC VAV with design component Prisma

Length (m)	Dry weight* (kg)	Weight, filled with water* (kg)	
		A: Cooling	B: Cooling/Heating
1.2	20.1	21.1	21.3
1.8	28.8	30.3	30.7
2.4	37.1	39.2	39.7
3.0	44.8	47.4	48.1

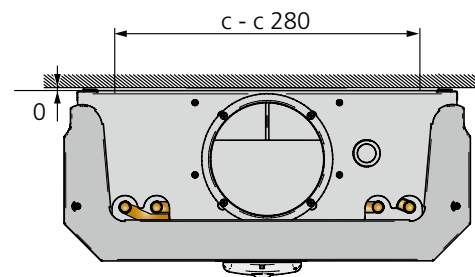

Figure 34. Installation - directly against ceiling with assembly fitting ADRIATIC d-T-MD-4S.

Weight - ADRIATIC VAV with design component Ellips

Length (m)	Dry weight* (kg)	Weight, filled with water* (kg)	
		A: Cooling	B: Cooling/Heating
1.2	20.5	21.5	21.7
1.8	29.2	30.7	31.1
2.4	37.7	39.8	40.3
3.0	45.8	48.4	49.1

* excl. controller (VAV = 0.723 kg, WISE = 0.598 kg), valves, actuators and sensors.

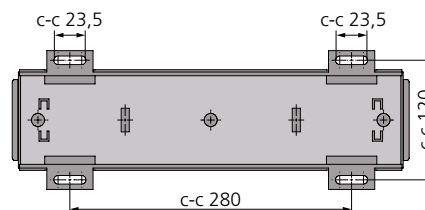

Figure 35. ADRIATIC d-T-MD-4S c-c measure

Specification

ADRIATIC VAV climate beam for demand-controlled ventilation, including ADC air deflector for cooling and ventilation or cooling, heating and ventilation.

The units are supplied painted in Swegon's standard shade of white, RAL 9003, gloss ratio 30 ±6%.

Product

Climate beam for demand-controlled ventilation

ADRIATIC VAV	d	a-	bbb-	c-	d
Version					
Function:					
A = Cooling and supply air					
B = Cooling, heating and supply air					
Length m:					
1.2, 1.8, 2.4, 3.0					
Variant:					
P = Prisma					
E = Ellips					
With sensor module in the design component					
1 = no					
2 = yes					

Colour

The product, the connection casing and the surface mounted assembly piece are painted as standard in RAL 9003 standard colour, white, gloss ratio 30 ± 6%, but can also be ordered in the following colours.

RAL 7037 Grey, gloss ratio 30-40%

RAL 9010 White, gloss ratio 30-40%

RAL 9005 Black, gloss ratio 30-40%

RAL 9006 Silver, gloss ratio 70-80%

RAL 9007 Grey, gloss ratio 70-80%

Special Types

On request, the product, the connection casing and the surface mounted assembly piece can also be supplied painted in an optional colour or relief finish paint.

For further details about special types, get in touch with your nearest Swegon representative.

Accessories

Connection casing	ADRIATIC d KA-	aaaa bbbb
Length: (mm)		
200-350, 300-450, 400-550,		
500-650, 500-1000, 900-1050		
900-1350, 900-1750, 1600-1750,		
1600-2450, 1600-3150		

Connection casing with end connection panel	ADRIATIC d- KA-G	aaaa
Length: (mm)		
200, 300, 400, 500, 900, 1600		

Assembly fitting (For suspended installation)	SYST MS M8	aaaa-	b-	RAL9003
Length of threaded rod:				
200, 500, 1000 mm				
1 = threaded rod only				
2 = Double threaded rods with thread locking device				

Assembly fitting (For installation directly against the ceiling)	ADRIATIC d-T-MD-4S	a
Quantity per pack		
2 = 2 pcs		
3 = 3 pcs		

Room unit	LOCUS	a-	b
Version:			
Frame colour:			
W = white			
B = black			

Flexible connection hose (1) Clamping ring coupling against pipe on both ends Length: 300, 500 and 700 mm Dimension (Ø) mm: 12	SYST FH F1	aaa	12
---	------------	-----	----

Flexible connection hose (1) Quick-fit coupling (push-on) against pipes at both ends Length: 275; 475 or 675 mm Dimension (Ø) mm: 12	SYST FH F20	aaa	12
---	-------------	-----	----

Flexible connection hose (1) Quick-fit coupling (push-on) against pipe on one end, G20ID sleeve nut on the other end Length: 200; 400 or 600 mm Dimension (Ø) mm: 12	SYST FH F30	aaa	12
---	-------------	-----	----

Connection piece (90° duct bend)	SYST CA-125-90		
-------------------------------------	----------------	--	--

Contractor demarcation

Swegon's delivery ends at the connection points for water and air and the connection of the room control equipment, see figures 26-30 and 31-35.

- Contractor demarcation at the connection points for water and air according to dimensional drawings
- The contractor demarcation for electric connection point according to dimension print
- The pipe contractor connects the connections points for water to the plain pipe ends and fills the system, bleeds it and tests the pressure, and assumes responsibility for the design water flows reaching each branch of the system and the index unit

Cooling, supply and return (Cu) Ø 12 x 1.0 mm	Heating, supply and return (Cu) Ø 12 x 1.0 mm
--	--

Observe recommendations regarding water quality!

When the room control equipment is installed at the factory, the cooling and heating water's return line is connected to the valve.

Function		Type	Dim.
Cooling	Cooling/heating	VDN215	DN15 (½")

- The ventilation contractor connects ducting to the air connecting piece ø125 mm.
- The ventilation contractor conducts initial commissioning of the air flows
- The electrical contractor connects the power (24 V) and signal cables to the connection terminal with spring-loaded snap-in connections. Maximum cable cross section 2.5 mm². For safe operation, we recommend cable ends with ferrules.

Further information is available for download from www.swegon.com

ADRIATIC VAV installation instructions (IOM)

LOCUS Product datasheet

LOCUS Instructions for Use

SWICCT manual

VAV-Modbus manual, Modbus settings for VAV products

Specification text

VVS AMA PTD.4 0	Product with cooling & heating	
AMA-codes	XXX	Page 1
CODE	TEXT	QUANTITY
P	UNITS; PIPES ETC IN PIPE SYSTEMS OR PIPE NETWORKS	
PT	ROOM MOUNTED HEATER AND COOLER	
PTD	ROOM DEVICES FOR HEATING AND COOLING	
PTD.4	Duct connected room devices for heating and cooling	
P	UNITS; PIPES ETC. IN PIPE SYSTEMS OR PIPE NETWORKS	
PT	ROOM MOUNTED HEATER AND COOLER	
PTC	ROOM CHILLERS	
PTC.3	Chilled beams and convectors	
PTC.31	Chilled beams	
PTC.312	Duct connected chilled beams	
XXXX		
Make:	Swegon	
Type:	<p>ADRIATIC VAVd – A or ADRIATIC VAVd – B (cooling and heating are always included in the coil, regardless of whether A or B is selected).</p> <p>Climate beam with the potential to add integrated, pressure-independent VAV control.</p> <p>Waterborne cooling and heating for suspended installation or installation directly against the ceiling.</p> <p>Slot adjustment for retained air distribution and function, and to ensure that throw lengths are achieved, even at low air flows.</p> <p>Two-way air discharge climate beam with integrated comfort guarantee (ADC) for setting of the desired direction of the distributed air.</p> <p>Asymmetric air flow on the different sides is possible.</p> <p>Steplessly adjustable air flow.</p> <p>Two possible choices of design component, an angular variant "Prisma" and a rounded variant "Ellips".</p> <p>The design component is easily opened with the aid of "pushbuttons", and then hangs down along one long side.</p> <p>Actuators and controllers are concealed below the design component for a more minimalist expression.</p> <p>Air connection and water on the product's short side.</p> <p>Connection casing for covering pipes, designed to fit the selected design component.</p> <p>The product is Eurovent certified (verified cooling capacity according to EN-15116).</p>	
CODE	TEXT	QUANTITY
Colour:	White, RAL 9003, gloss ratio 30 ± 6 %	
Length (nominal):	1210, 1810, 2410, 3010 mm (Prisma) 1214, 1814, 2414, 3014 mm (Ellips)	
Width (nominal):	450 mm (Prisma), 513 mm (Ellips)	
Height:	190 (Ø125) mm (Prisma), 194 (Ø125) mm (Ellips)	
Tolerances:	± 2 mm	
Water connection:	Plain pipe ends Cu Ø12 x 1.0 mm; Cu Ø12 x 1.0 mm Alt.: 1.2/1.8/2.4/3.0: Male thread cooling and heating DN 15 (applies to factory-fitted valves).	
Air connection:	Spigot Ø125 Air and water connect to the same short side	
Product:	ADRIATIC VAVd-B-ccc-d or ADRIATIC VAVd-A-ccc-d	X pcs.

VS AMA PTD.4 0	Product with cooling & heating, continued	Page 2
AMA-codes	XXX	
CODE	TEXT	QUANTITY
Options/accessories Factory-fitted:		
	Various Design components	X pcs.
	Prisma, a design component with angles and a severe appearance.	
	Ellips, a design component with rounded lines that give a calm and gentle expression.	
	SYST VDN 215	X pcs.
	Valve (straight)	
	DN15 (1/2"), Normally open, Kv-value 0.89 (adjustable 0.07-0.89)	
	ACTUATORc Thermal actuator	X pcs.
	On/off - 24 V AC/DC Normally closed	
Accessories, supplied loose		
	ADRIATIC d-T-MD-4S	X pcs.
	Assembly fitting for installation directly against ceiling	
	SYST MS M8 aaaa-b-RAL9003	X pcs.
	Assembly piece for suspended installation	
	assembly fitting containing threaded rods, ceiling brackets and nuts to all four mounting brackets.	
	SYST VDN 215 / SYST VDN 220	X pcs.
	Valve (straight)	
	DN15 (1/2"), Normally open, Kv-value 0.89 (adjustable 0.07-0.89)	
	DN20 DN20 (3/4") Normally open, Kv-value 1.41 (adjustable 0.22-1.41)	
	90 SYST CA	X pcs.
	90° duct bend for air connection. Nipple connections with seals.	
	Dimension: Ø125 mm	
	SYST FH aaa- bbb - 12	X pcs.
	Flexible connection hose (available in different variants)	
	SYST AR-12 X pcs.	X pcs.
	Nipple for venting the water circuit. Push-on connector adapted for installation with flexible connection hose type F20 and F30.	
	SYST AD1	X pcs.
	Double nipple for the connection of the air duct to the product's air connection sleeve.	
	ADRIATIC d-KA-aaaa bbbb	X pcs.
	Connection casing	
	ADRIATIC d-KA-G aaaaa	X pcs.
	Connection casing with end connection panel etc.	