

ABSORPTION CHILLERS

GREEN SOLUTIONS FOR ENERGY SAVING

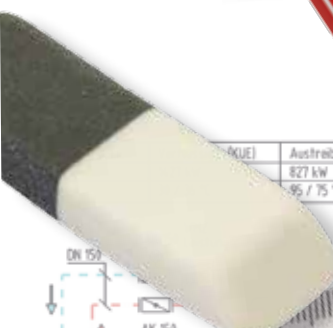

AKUE1	Austrreiber (H2O)
	827 kW
	95 / 75 °C





1. Introduction	Page 4
Types of absorption chillers	Page 4
Working principle	Page 4
Water/Lithium bromide type absorption chillers classification	Page 8
Double effect cycle	Page 8
Chemicals	Page 9
General considerations	Page 10
2. Available solution	Page 12
3. Product range - General overview	Page 13
4. 5G Small series	Page 15
5. 5G Twin series	Page 23
6. HD 10, SD 10, ED 10 and GD 10 series	Page 31
7. HS/SS series	Page 39
8. 2G/2B series	Page 47
9. 2D series	Page 55
10. 2V series	Page 61
11. EJ series	Page 67
12. High efficiency Chiller/Heater	Page 73
13. 3B/3D series Triple effect	Page 79
14. Heat pumps	Page 85
15. Low temperature machines	Page 91
16. References	Page 96



Conventional, mechanical compression refrigeration is used in many different ways and is well proven, with a good support network of suppliers and maintenance companies. It is unlikely that absorption cooling will replace conventional systems on a large scale, but there are many applications where it can offer an environmentally and economically superior alternative. Generally speaking, absorption cooling is worth considering if one of the following factors apply:

- There is a cogeneration plant and it is not possible to use all the available heat, or there is a new cogeneration plant under design.
- Waste heat is available
- A low cost source of fuel is available (for example gas)
- Plant boiler efficiency is low due to a poor load factor (particularly in summer)
- It is not possible to satisfy the electrical load of the plant
- The site is particularly sensitive to noise and vibrations.
- The site needs more cooling but has an electrical load limitation that is expensive to overcome, and there is an adequate supply of heat.

In short, absorption cooling will find its application when a source of free or low cost heat is available, and/or if there are objections to the use of conventional refrigeration.

TYPES OF ABSORPTION CHILLERS

There are several types of absorption chillers; the two basic ones are:

1. Lithium bromide/water systems
2. Ammonia/water systems

THERMAX absorption chillers belong to the first category: water is the refrigerant and lithium bromide is the absorbent.

WORKING PRINCIPLE

Absorption chillers operate on the basis of three well known physical phenomena:

- A. When a liquid evaporates (or boils) it absorbs heat, and when it condenses it gives up heat.
- B. Boiling temperature of a liquid is a function of the pressure: as this one decreases, the first one decreases.
- C. There are some pairs of chemicals that have a strong affinity to dissolve in one another.

In a conventional, mechanical vapour compression cycle, the refrigerant evaporates at a low pressure producing cooling. It is then compressed in a mechanical compressor to a higher pressure, where it condenses. In most of the machines in the market, the compressor is normally powered by an electric motor.

In an absorption chiller the evaporator and condenser are essentially the same, but a chemical absorber and a thermal generator replace the compressor, with a pump to provide pressure change. As a pump requires much less power than a compressor, electrical power consumption is much lower.

Let's see how the physical basics illustrated above are used in an absorption chiller.

1. Introduction



1. Consider a tube bundle in a closed vessel with some water to be cooled flowing in the tubes. Let's make vacuum inside the vessel. For what is said at point B, pressure and accordingly boiling temperature of water inside the vessel decrease. For example at a pressure of 0,8 kPa corresponds a boiling temperature of approximately 3,7°C. Let's spray some water on the outside surface of the tube bundle inside the vessel: if the temperature of the water flowing in the tubes is higher than the boiling water temperature corresponding to that pressure, for what is said at point A sprayed water evaporates, absorbing heat from the water flowing inside the tubes. So the cooling process is obtained. The vessel section where this tube bundle is located is called EVAPORATOR.

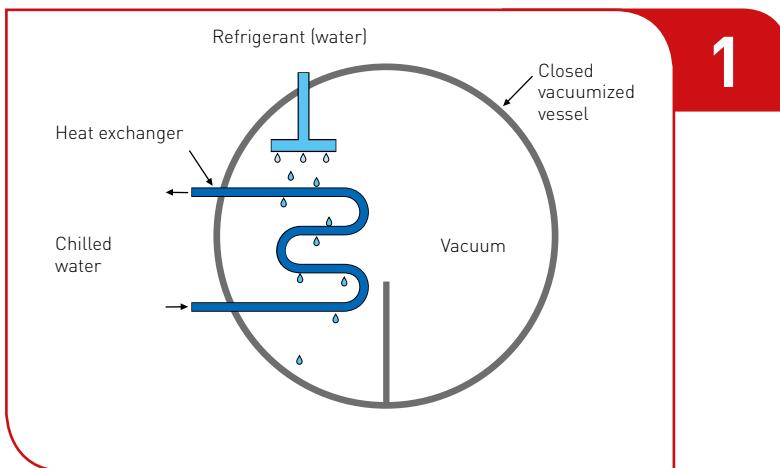

2. Actually the above illustrated process is going to stop itself very quickly if necessary adjustments are not taken. As the water evaporates, pressure inside the vessel (and accordingly boiling temperature of water) increases. When boiling temperature becomes higher than the temperature of the water flowing in the tubes, evaporation process (and consequently cooling process) stops. The problem is solved using what is said at point C: in this case the chemicals used are water and lithium bromide. Lithium bromide has a great affinity with water and it has a great hygroscopic power. If we spray a solution of water and lithium bromide inside the vessel, this will absorb all the vapours generated by the evaporation of water on the evaporator tube bundle. So pressure inside the vessel is kept constant at 0,8 kPa and the cooling process can go on. The absorption of the water by the lithium bromide is an exothermic process, it means heat is generated that has to be removed from the system. For this reason there is a second tube bundle in the vessel where some cooling water is flowing in: so temperature inside the vessel is kept constant. The vessel section where this second tube bundle is located is called ABSORBER.

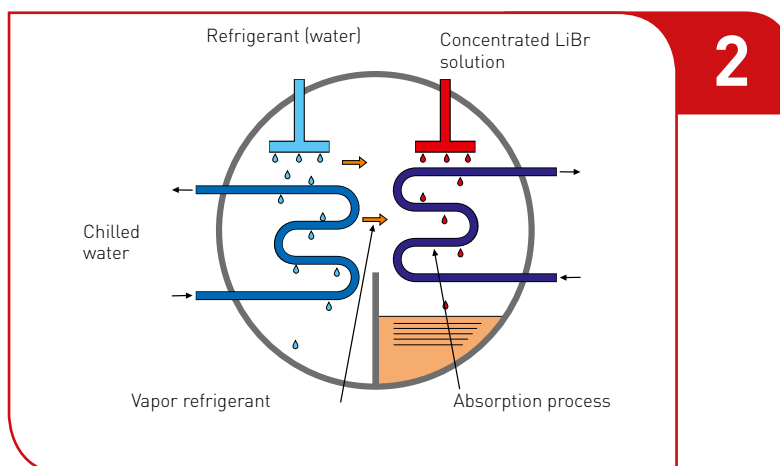

3. Hygroscopic properties of the solution of water and lithium bromide don't remain constant. They basically depend on two factors:
 - a) Temperature: the affinity between lithium bromide and water increases itself as temperature decreases.
 - b) Concentration: when this one is very low (it means the quantity of the salt in the solution is very low) the absorption capacity of the solution is very low.

Regarding the first point, the water flowing inside the absorber tubes keeps the temperature inside constant. Regarding the second point, the absorption process starts to become less effective as the amount of water absorbed in the solution grows. To keep constant the effectiveness of the process it is necessary to bring the concentration levels back to the initial point. The easiest way to do it is to boil the solution: due to the different vapour pressures of water and lithium bromide, during the evaporation process only the water evaporates. So the concentration of the solution increases. The boiling process takes place in dedicated vessel called GENERATOR where the dilute solution is collected. The generator is fired with the available heat source: hot water, steam or directly the combustion of a fuel. Once the boiling process is completed, the concentrated solution is sent to the absorber to absorb the vapours generated in the evaporator .

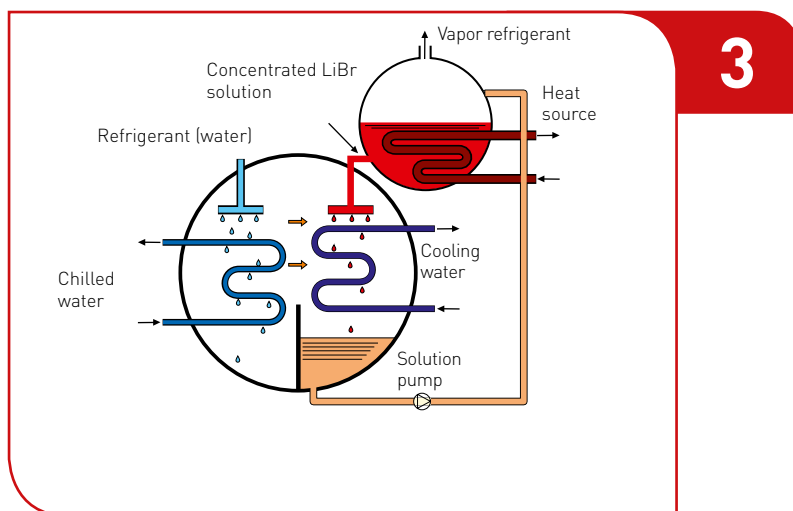

4. In the generator also water vapours are generated together with the concentrated solution. They are sent to another heat exchanger called CONDENSER where they are condensed by a cooling water flow (the same water that is flowing in the absorber). This condensed water is used as refrigerant to be sprayed in the evaporator to generate the cooling effect. So the working cycle of the machine is completely closed.

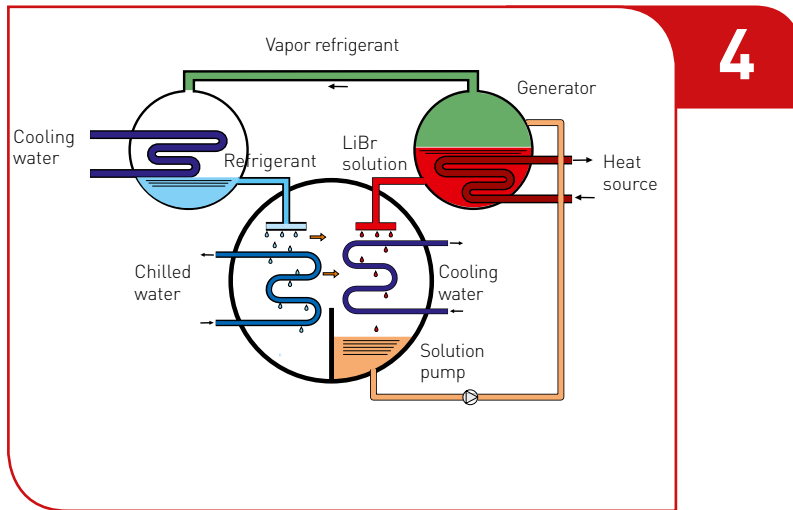

5. Basic working cycle for a single effect absorption chiller.

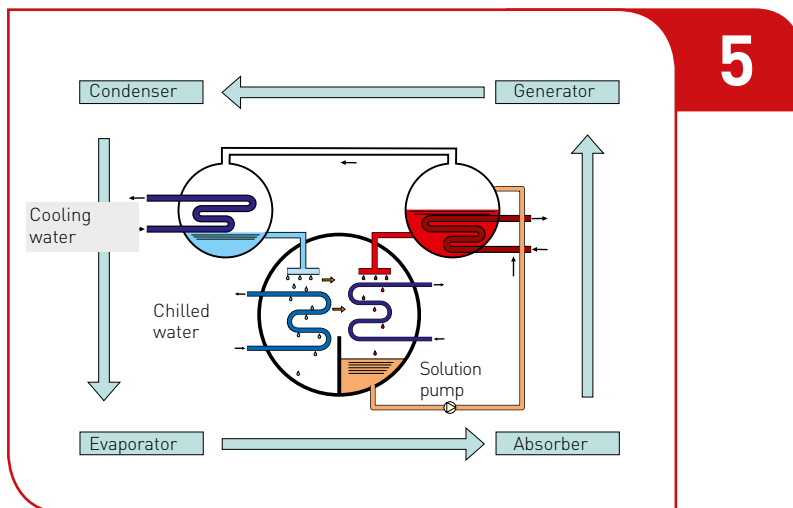

WATER/LITHIUM BROMIDE TYPE ABSORPTION CHILLERS CLASSIFICATION

It is useful and common practice to divide absorption chillers into categories in different ways: by the type of heat source and by the number of effects.

Type of heat source

Heat is generally supplied to the absorption unit as one of the following:

- hot water
- steam
- directly by burning fuel (direct fired)
- exhaust gases

Number of effects

In the market it is possible to purchase single and double effect machines. Triple effect units have been recently launched. Double effect machines are more efficient than single effect, but also cost more.

The determining factor in the choice of one type respect to the other is the temperature at which heat is available.

Furthermore, for each type of machine, single or double stage evaporation/absorption is available. Single or double stage evaporation/absorption must not be confused with single or double effect.

Following there is a simplified scheme showing the different heat sources (and their temperatures) with the number of effects.

Hot water	from 75°C to 150°C single effect, from 150°C a 185°C double effect, from 185°C to 240°C triple effect
Steam	from 50 to 350 kPa (g) single effect, from 400 to 1000 kPa (g) double effect, from 1200 to 2500 kPa (g) triple effect
Direct fired	double effect
Exhaust gases	double effect/ triple effect

DOUBLE EFFECT CYCLE

The cycle described in the above pages refer to a single effect machine. It can be well illustrated by the following scheme:

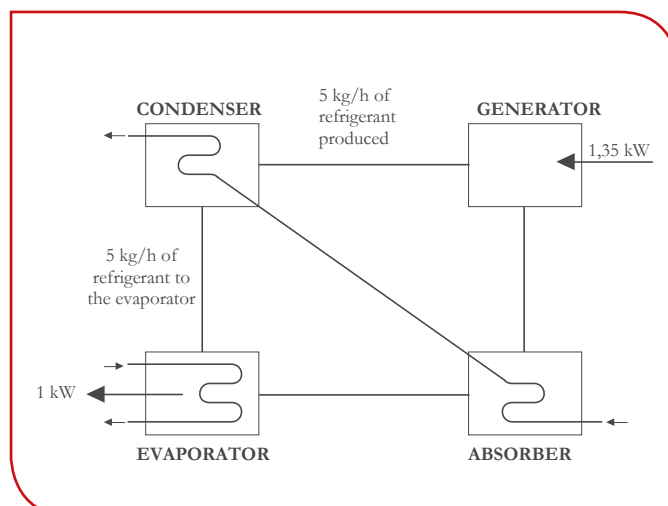

In a hot water fired single effect machine approximately 5 kg/h of refrigerant have to evaporate in the evaporator to produce 1 kW of cooling: it means that the generator should receive enough heat to boil 5 kg/h of refrigerant out from the solution that will be sent to the evaporator once condensed. When the available heat source is very hot, the refrigerant vapours coming out from the generator and going to the condenser are also very hot. Their temperature is so high that they can be used to boil the solution a second time, so that an extra quantity of refrigerant is available to be sprayed in the evaporator. For this purpose a second generator is added to the machine (it is called low temperature generator, while the main one is called high temperature generator): in this one the heat source is the refrigerant vapour coming from the first generator.

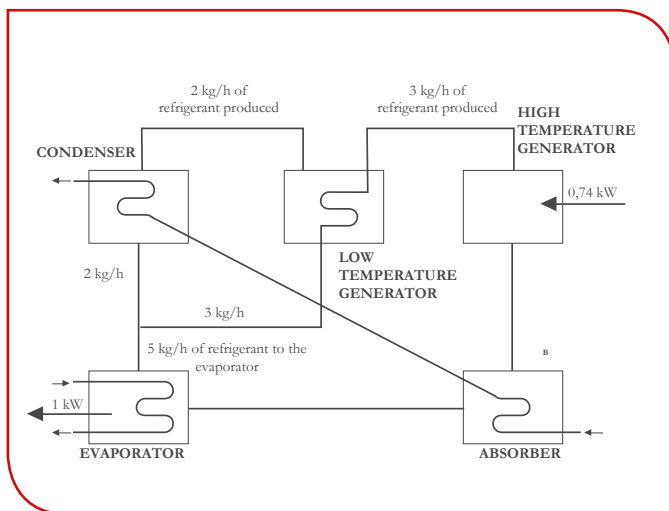

Analysing this scheme it is possible to notice that in this case only 3 kg/h of refrigerant are generated in the high temperature generator. It means that to produce 1 kW of cooling the machine has to be fired with less heat than a single effect one: in fact 2 kg/h of refrigerant are generated by waste heat inside the machine that otherwise would have been dissipated. So a double effect machine requires less quantity of primary energy to produce the same cooling capacity, or in other words its efficiency is greater than the one of a single effect machine.

In double effect machines the second generator makes it possible to design different working cycles, changing the path of the solution from one generator to the other: so there are parallel, series or reverse cycles. Main features of each cycle are described in the description of each model series.

CHEMICALS

- **Lithium Bromide (LiBr)**

Lithium bromide is a salt with similar characteristic of sodium nitrate (NaCl), the common salt. So it is easy to imagine lithium bromide properties. It is well known that when salt is left in a high humidity atmosphere, it becomes sticky. This is because it absorbs moisture from the atmosphere. Lithium bromide has the same characteristic and its absorption power is 17 times stronger than the one of the common salt. The higher the concentration and the lower the temperature of lithium bromide solution are, the stronger its absorption power is.

- **Lithium molybdate**

LiBr has a corrosive action towards a metal in the presence of oxygen. Since the absorption chiller is a vacuumed vessel, almost no oxygen is present in the vessel. However due to some maintenance operation or some bad action, air could come inside the machine. To be on safer side the corrosion inhibitor is added in the solution and further the alkalinity is also adjusted. The inhibitor forms a hard protective layer on the metallic surfaces, protecting them from corrosion. As this layer starts form-

ing, the inhibitor concentration decreases. For this reason a periodic chemical analysis of the solution to check the amount of inhibitor (ppm) and to add the calculated make up quantity is recommended. Excessive quantities of molybdate have to be avoided, since it may react with lithium bromide, affecting chiller performances.

- **Water**

The refrigerant used in the absorption machines is water. The water has to be pure and without contaminants. For this reason distilled water is used.

- **Octyl alcohol**

In order to increase the absorption effect of the solution, a small quantity of octyl alcohol is added into the machine. Main purpose of this alcohol is to make the liquid layer covering the tube bundle more turbulent, increasing heat and mass transfer. Overcharging however has to be avoided since it causes the choking of the heat exchangers resulting in a decrease of the capacity.

GENERAL CONSIDERATIONS

Temperature limitation

Lithium bromide/water units have a limitation on the chilled water temperature they can produce. For most practical purposes, this is limited to 3,5-4°C. This limitation is caused by the use of water as refrigerant and cannot be solved by adding an antifreeze agent to the chilled water, as for conventional chillers. As of now, THERMAX can offer a line of special designed machines where chilled water temperature can be reduced as low as -5°C under certain circumstances.

Heat rejection

Absorption chillers reject into the atmosphere a greater amount of heat than conventional electrical chillers. This means that cooling towers will be larger. As a general rule the heat that has to be dissipated is approximately 2,4 times the cooling capacity in single effect machines and 1,7 times in double effect machines.

Extremely important is also the temperature at which heat is rejected from the system, so inlet and outlet cooling water temperatures are important. This is because the cooling water is flowing in both the cooling and the condensing section of the machine. Absorption chillers are much more affected by the cooling water temperature than conventional mechanical ones. This has to be taken into account while sizing the cooling tower or the cooling system. Anyway there is also a lower limit to the cooling water temperature: too low temperatures can lead to crystallisation.

Crystallisation

Crystallisation has always been considered one of the major problems of the lithium bromide/water absorption chillers. PLC based control systems development occurred in the last ten years has greatly reduced the possibilities of the phenomenon to take place or to grow. In spite of this, talking about lithium bromide/water absorption chillers, crystallisation is the first word that is associated to the machine. So let's try to understand what crystallisation is.

What is crystallization?

Suppose to have a solution of water and salt. Having fixed a certain temperature, if the solvent (water) is continuously removed from the solution, this one becomes saturated, it means the solvent has reached the maximum capacity to solve the solute (the salt). If more quantity of solvent is removed from the solution, the excess solute will form solid aggregates called crystals. This phenomenon is known as crystallisation. So crystallisation is nothing more that the appearing of the salt in the solid state inside the solution. Actually it depends upon the following:

1. Introduction



- Temperature of the solution.
- Concentration of the solution.

For a particular solution, it is possible to draw a graph temperature-vapour pressure at different concentrations. An example is reported below. In this graph a particular line called "crystallisation line" is underlined: it shows the highest concentration that can be reached for every temperature: at the right of this line the salt is present in solid state and not more diluted in the solution.

In this graph also a double effect machine working cycle is reported. As temperatures inside the machine change the cycle shifts in the graph: the temperatures and the concentration levels inside the machine have to be such that this cycle never pass over the crystallisation line.

In an absorption chiller, crystallisation of the solution can occur due to one of these reasons or to a combination of them:

- a) Low cooling water inlet temperature.

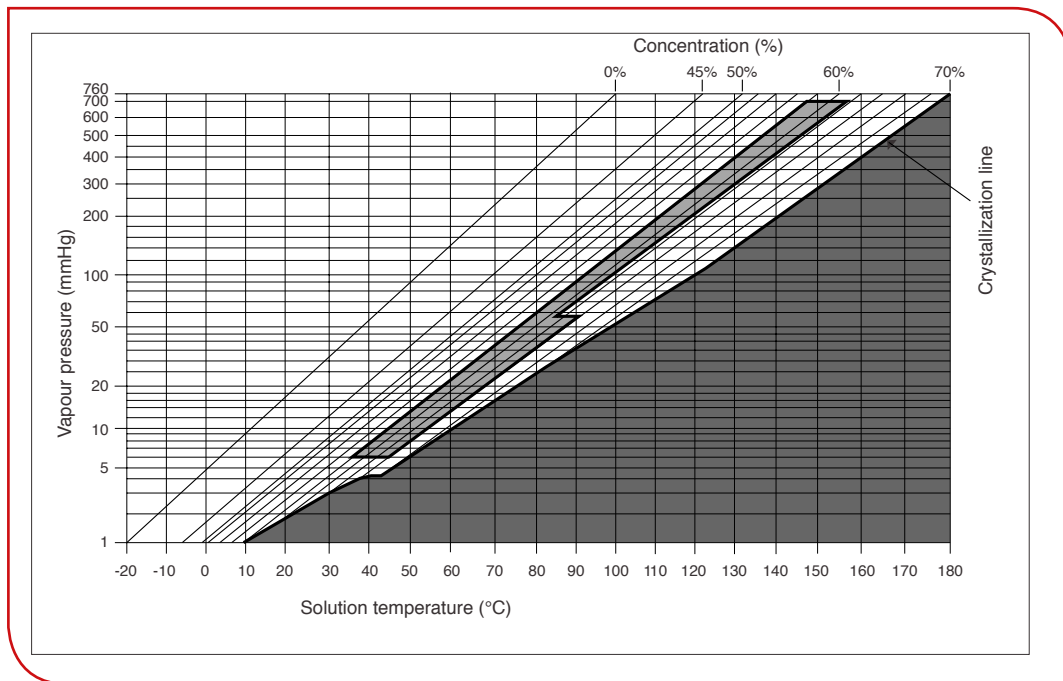

- b) Insufficient vacuum inside the machine.
- c) Insufficient solution flow.
- d) Excessive generator heating.

Each machine is provided with several safeties in order to prevent the appearing of the crystallisation: all these applies are illustrated in each series description.



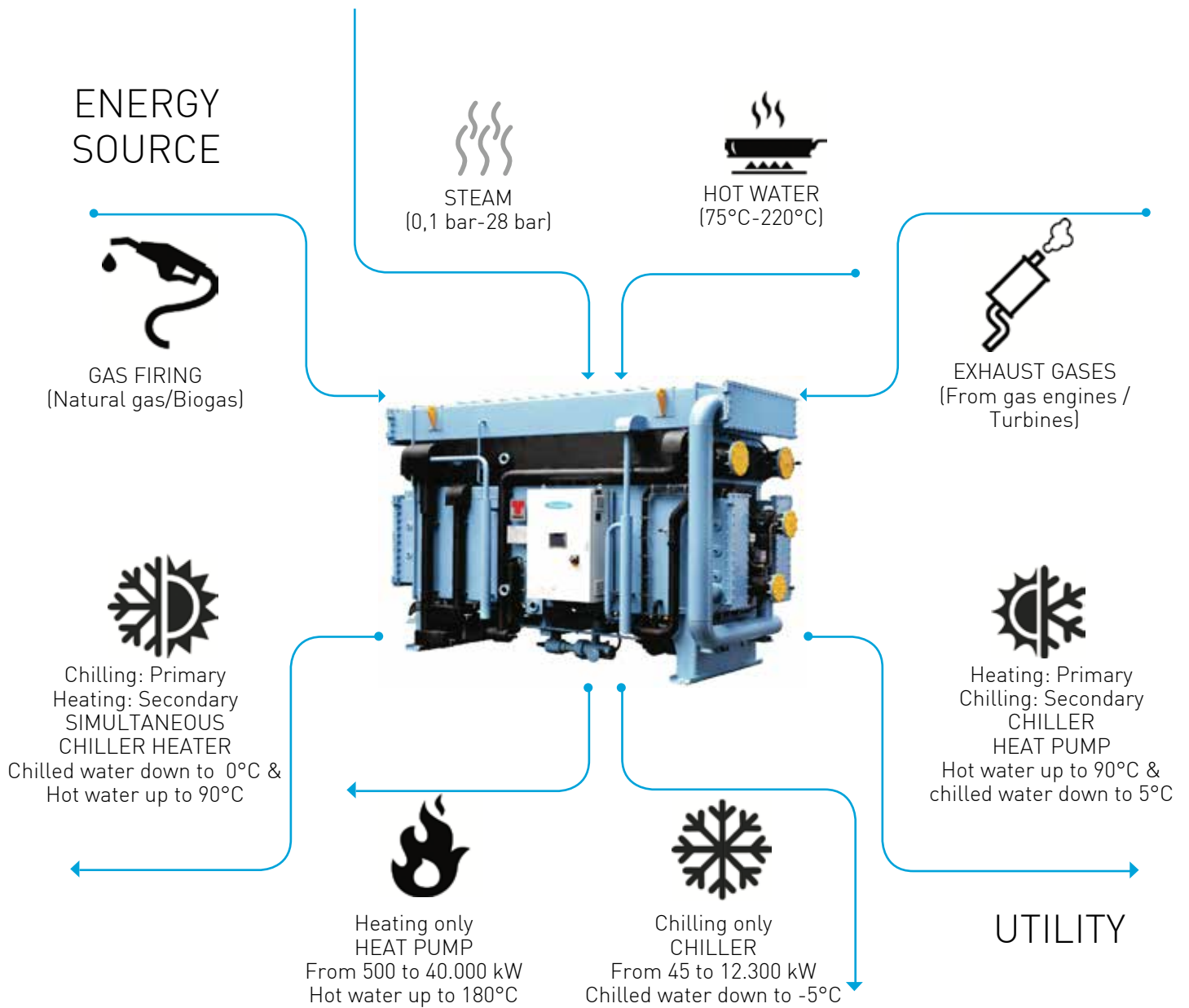

3. Product range - General overview



SS/HS Series
Capacity: from 350 to 12.300 kW
Heat source: Steam (SS)/Superheated water (HS)
Steam pressure: 0-3,5 bar g
Superheated water temperature: 120-150°C
COP: 0,7-0,75



2B series
Capacity: from 176 to 12.300 kW
Heat source: Steam
Steam pressure: 4-10 bar g
COP: 1,4



3B Series
Capacity: from 176 to 5.300 kW
Heat source: Steam
Steam pressure: 12-25 bar g
COP: 1,6-1,9



5G Series
Capacity: from 45 to 5.800 kW
Heat source: Hot water
Hot water temperature: 75-120°C
COP: 0,75-0,8



2G Series
Capacity: from 176 to 12.300 kW
Heat source: Superheated water
Superheated water temperature: 140-180°C
COP: 1,4



3G Series
Capacity: from 176 to 5.300 kW
Heat source: Superheated water
Superheated water temperature: 180-240°C
COP: 1,6-1,9



2V Series
Capacity: from 176 to 10.500 kW
Heat source: Natural gas/Biogas
COP: 1,4



2D Series
Capacity: from 176 to 12.300 kW
Heat source: Exhaust gases
Exhaust gases temperature: 250-600°C
COP: 1,4



EJ Multi Energy Series
Capacity: from 350 to 12.300 kW
Heat source: Exhaust gases+Hot water
Exhaust gases temperature: 250-600°C
Hot water temperature: 80-120°C
COP: 1-1,1



Heat pump - TYPE I
Capacity: from 500 to 40.000 kW
Heat source: Steam/Hot water/
Natural Gas/Exhaust gases
COP: 1,7-1,85



Heta pump - TYPE II
Capacity: from 500 to 15.000 kW
Heat source: Steam/Hot water
COP: 0,45-0,47



High Efficiency Chiller/Heater
Cooling capacity: from 176 to 10.500 kW
Heating capacity: from 100 to 9250 kW
Heat source: Steam
Steam pressure: 3-10,5 bar g





5G Small



IGT
IGT
ASCHI
MALE BEDIENUNGS- UND WARTUNGSFREIRÄUME
ALTSCHRANKSEITE : 1200
RHALB DER MASCHINE : 200
RE : 500

MINUTENTOLERANZEN:

L (MTR)	TOL (MM)
0-3	4
3-5	5
5-7	7
-10	10
VER 10	15

TSCHIBENAUSTRIIT IST ANZUSCHLIESS
OKALEN GESETZE UND RICHTLINIEN BI
AUSSEITIGE BERTSCHIBENVERROHRUN
ASCHINENOBBERKANTE NICHT ÜBERSCH
RUME ZUM ZIEHEN DER ROHRE NUR AUF
N FÄLLEN IN DENEN DIE BAUSEITIGE VER
TGEHEND IM VORFELD, VOR ANLIEFERUNG
CHLOSSEN WERDEN SOLL, DIE SCHWEIBNA
WEISEN, UM NACH DEM NIVELLIEREN DER
IKTURMAßNAHMEN VORNEHMEN ZU KÖNNEN
LICH DER FUNDAMENTARBEITEN BEZIEHEN
IE FUNDAMENTZEICHNUNG

1834 (W)

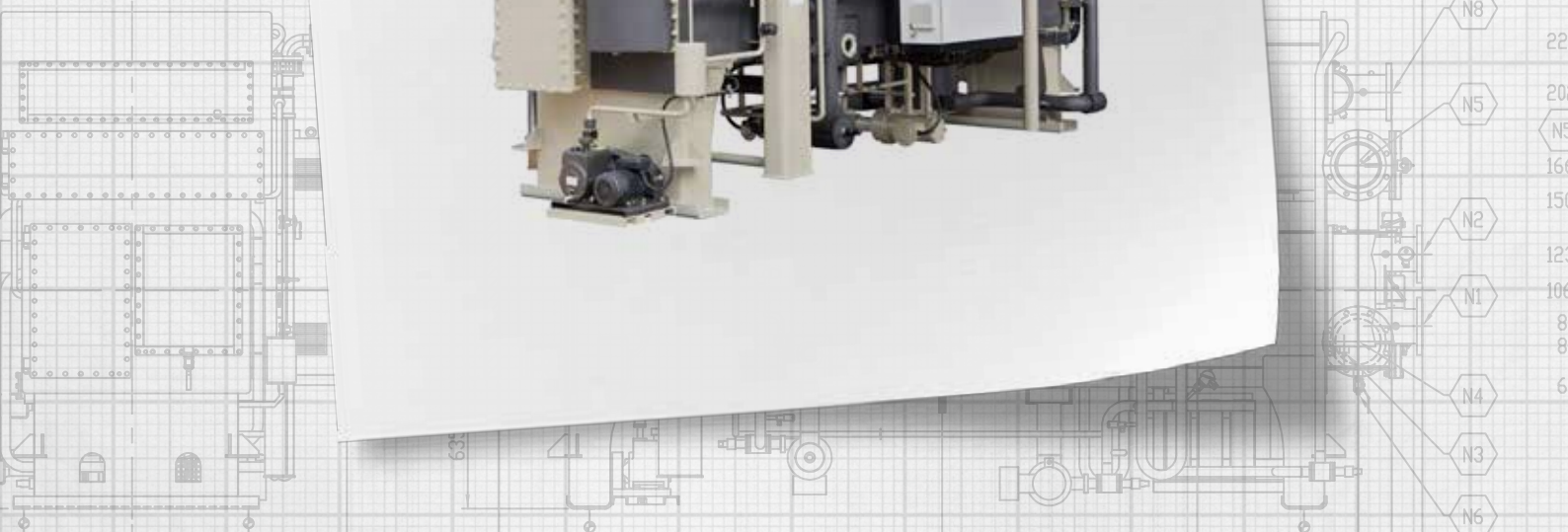
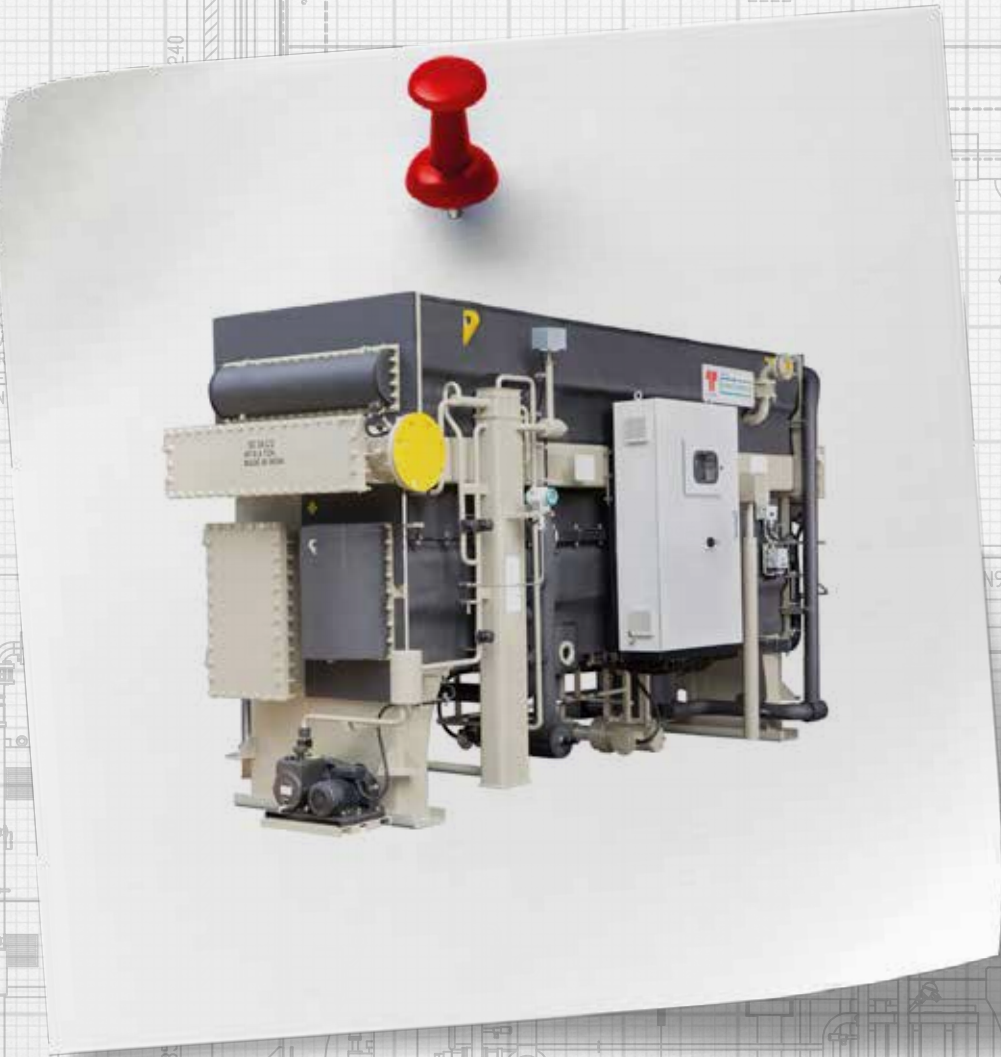

4. – 5G SMALL

Latest generation of single effect low temperature hot water fired absorption chillers.

The machines are specifically designed to be used with low temperature hot water, to maximize the efficiency and they are suitable to be used with high DT in water circuits.

This new generation of machines feature compact dimensions, easy to use, easy to maintenance and a high efficiency.

Cooling capacities from 45 kW to 780 kW.

Hot water inlet temperature between 75 °C and 120 °C.

COP: between 0,70 and 0,76

STANDARD FEATURES:

- Double shell design: the upper shell (including condenser and generator), the lower shell (including evaporator and the absorber).
- Compact design.
- Straight tubes in the generators for easy maintenance.
- Gravity feed spraying technology in evaporator and absorber. Liquids are sprayed downwards on the tubes to ensure good film thickness and better heat transfer.
- Marine type headers in absorber and condenser.
- Crystallization control and prevention based on on-line determination of actual measured concentration.
- Refrigerant autoblowdown solenoid valve controlled by solution concentration
- Level electrodes for refrigerant level monitoring in the evaporator. (excluded model 5G 1A C)
- PLC based control panel SIEMENS SIMATIC S7-1200
- Alarm state annunciation through an audio signal and appropriate messages display on the operator interface terminal.
- Operator panel SIEMENS TP700, 7" touchscreen.
- MODBUS RTU connectivity as a standard feature.
- Several field interlocks available for plant automation.
- Mini-finned SS 430 Ti tubes in generator
- DLP copper tubes in evaporator, absorber and condenser.
- Crystallization prevention safeties: overflow pipe for auto decrystallisation, low/high cooling water inlet temperature cut-out, high temperature control for generator, hot water control valve PLC control based on generator temperature.
- PID algorithm capable of achieving part load operation from 10 to 100% stepless, based on chilled water outlet temperature.
- Purge system, which continuously and automatically removes non condensable gases from the shell side and stores them in a tank. A purge pump is provided as standard feature.
- Regenerative heat exchanger to increase the efficiency of the cycle. The heat exchanger is plate type, with copper brazed stainless steel plates, designed for the maximum heat exchange with minimum pressure loss. The use of a plate heat exchanger ensures a compact design of the unit.
- Isolating valves for easy removal of the pumps for maintenance without breaking the vacuum inside the chiller (excluded model 5G 1A C)

- Antifreeze protection safeties: PLC inbuilt antifreeze alarm, antifreeze thermostat, low temperature cut-out for refrigerant pump (L-cut), flow switch (starting from model 5G 2A C) and D.P. switch for chilled water.
- Completely factory assembled and wired.
- Potential free contacts for remote and automatic operation of the machine: chilled, cooling and hot water pumps start/stop, cooling tower fans start/stop, remote start/stop of the machine, remote indication of machine status (on/off) and machine trip, remote setpoint.
- Rupture disk
- Digital vacuum transmitter
- Insulation of cold surfaces.
- TRG, a patented bearing monitoring system for monitoring the wear and tear of the bearings (through contacts inside control panel, starting from model 5G 2A C)

OPTIONAL:

- Stand by refrigerant and solution pumps (only for models from 5G 2E C to 5G 3B C).
- Special metallurgy for tubes (CuNi 95/5, CuNi 90/10, Stainless steel, Titanium).
- Tubesheet and headers cladding in case of use of bad quality water not suitable for carbon steel
- On line indication of healthiness of bearings of refrigerant and solution pump (on line TRG, starting from model 5G 2A C).
- Insulation of hot surfaces.
- Two pieces shipment: unit can be shipped in two pieces to be reassembled on site.
- Profibus connection.
- Ethernet or Modbus TCP/IP connection.
- Palladium cell for automatic and static removal of hydrogen from purge tank.
- Autopurge system for automatic purging of purge tank (electric or pneumatic, starting from model 5G 2A C). Alternative to palladium cell.



Absorption chiller of 5G Small series

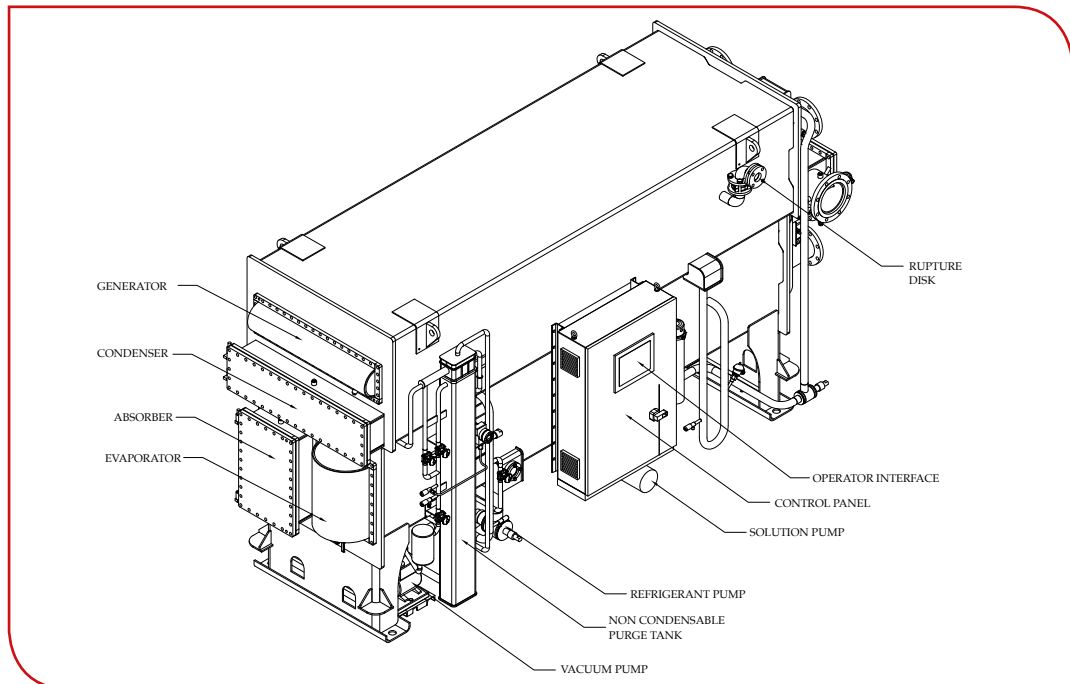

3D view of a 5G Small machine with main components - Control panel side view

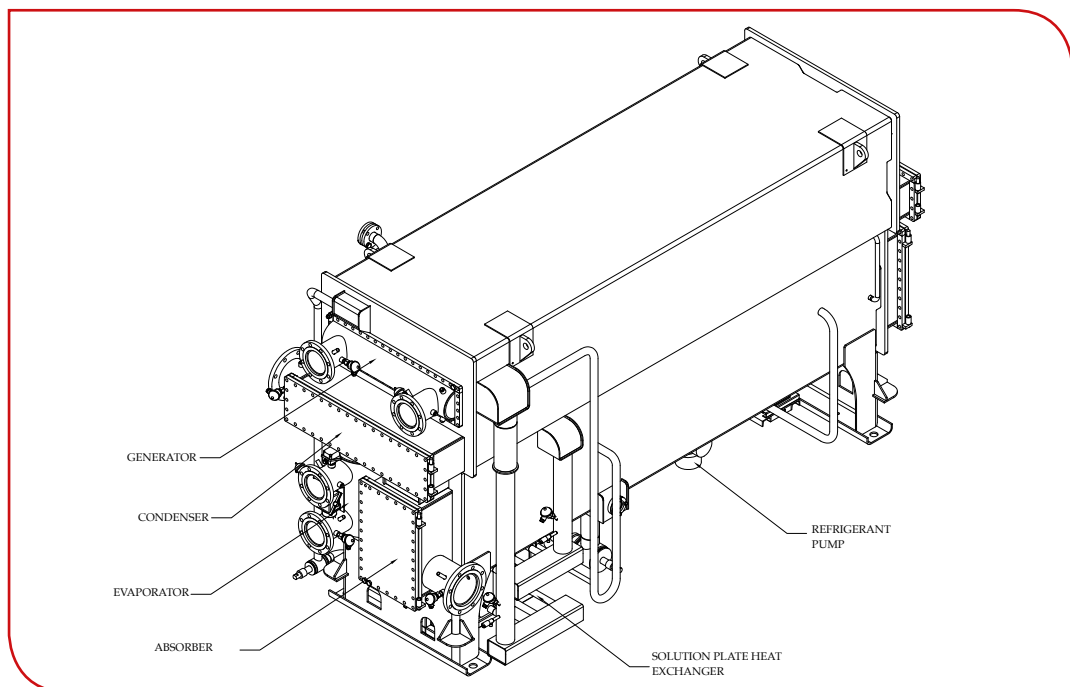

3D view of a 5G Small machine with main components - Rear view

4. 5G Small series

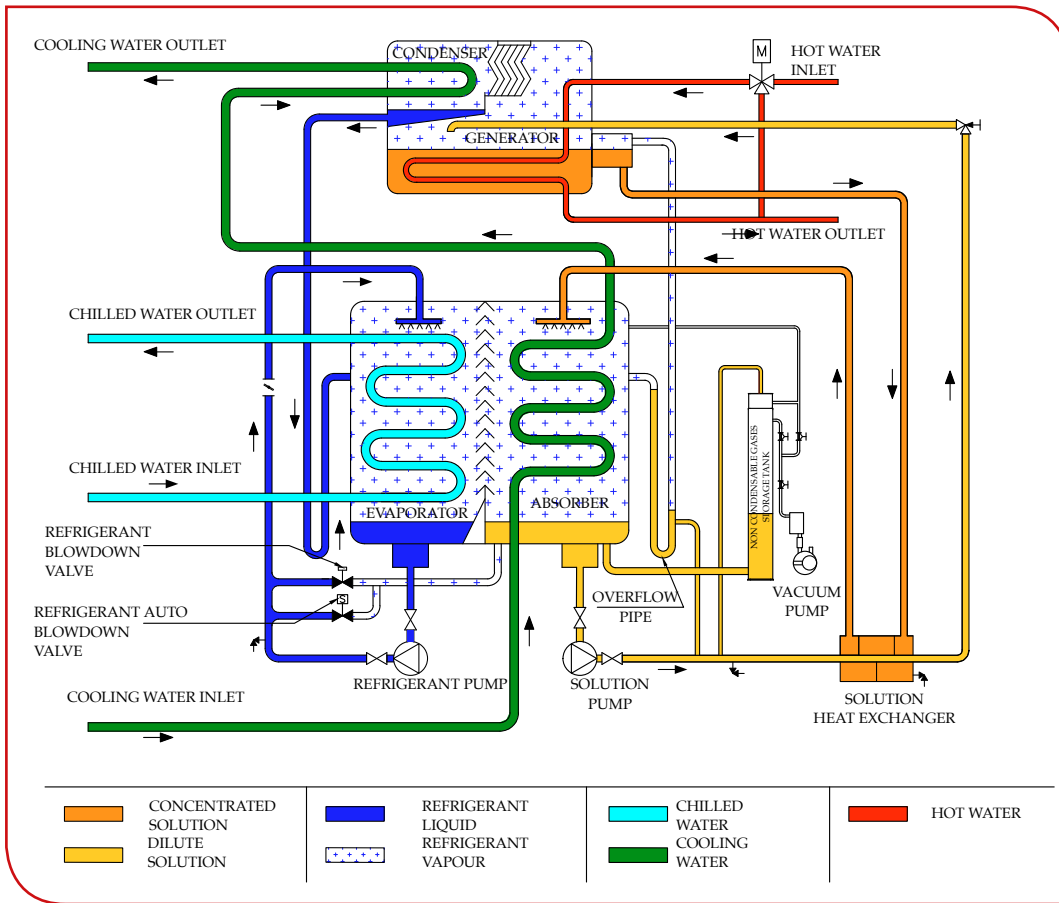

5G Small series working cycle

		UNITS	5G 1A C	5G 1B C	5G 1C C	5G 2A C	5G 2B C	5G 2C C	5G 2D C	5G 2E C	5G 3A C	5G 3B C
Cooling capacity		kW	61	122	182	238	324	395	470	568	692	792
	Chilled water	Flow	m ³ /h	10,5	21	31,3	40,9	55,7	67,9	80,8	97,6	119
	Connection diameter	DN	50	80		100		125		150		200
Cooling water	Flow	m ³ /h	26	48,5	75,9	93,6	135	160	190	230	282	321
	Connection diameter	DN	80	100		125		150		200		250
Hot water	Flow	m ³ /h	7,9	15,4	22,8	29,7	40,2	47	56	67,6	82,3	94,2
	Connection diameter	DN	50	80		100		125		150		200
Dimensions	Length (L)	mm	1670	2535		2840		3755		4360		4415
	Width (W)	mm	1400	1635		1575		1655		1870		1870
	Height (H)	mm	1820	2200				2310				2420
Weights	Shipping weight	x1000 kg	2,0	3,6	3,8	4,4	4,6	5,7	5,9	6,6	7,7	8,0
	Working weight	x1000 kg	2,2	3,9	4,2	5,0	5,2	6,5	6,8	7,7	9,1	9,5
Clearance	Clearance for tube removal	mm	1250	2110		2350		3390		4000		4060
Electrical data	Solution pump	kW(A)		1,1 (3,4)					1,5 (5)			
	Refrigerant pump	kW(A)		0,1 (0,55)					0,3 (1,4)			
	Vacuum pump	kW(A)					0,75 (1,8)					
	Power consumption	kVA		5,1					6,9			
	Power supply			415 V (±10 %), 50 Hz (±5 %), 3 Phase+N								

1) Model code: 5G XX - C low temperature hot water fired absorption chiller, 2) Inlet/Outlet chilled water temperature = 12/7 °C, 3) Inlet/Outlet cooling water temperature = 29/34 °C (29/34,3°C for models 5G 1B C and 5G 2A C), 4) Inlet/Outlet hot water temperature = 90°C/80°C, 5.a) Fouling factors: chilled water and hot water - 0,018 m²-K/kW, b) Fouling factor cooling water - 0,044m²-K/kW, 6) Minimum chilled water outlet temperature 3,5°C; lower temperatures upon request, 7) Minimum cooling water inlet temperature 18 °C, 8) Plantroom minimum/maximum temperature 5-45 °C, 9) Maximum working pressure in water circuits = 8 bar(g); higher pressures available upon request at extra price, 10) Please contact Thermax representative/office for customised specifications.



NOZZLES ORIENTATION DEPENDING ON NUMBER OF PASSES:

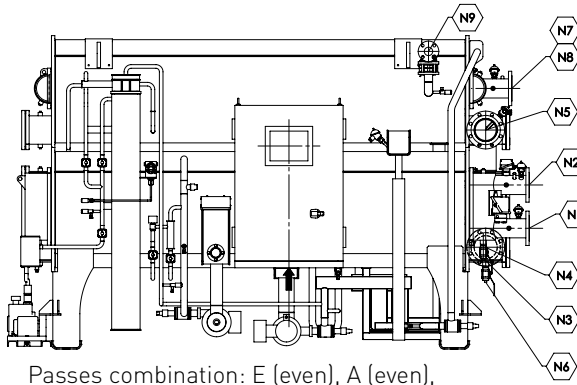

Passes combination: E (even), A (even),
C (even), G (even)

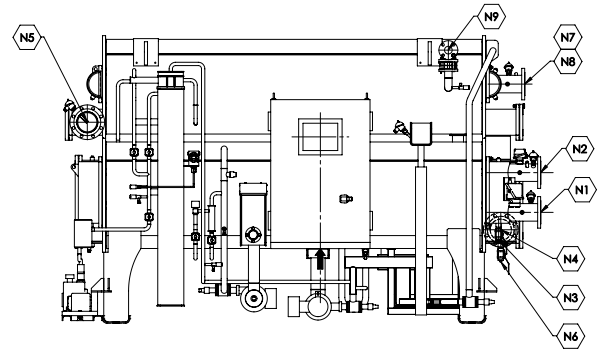

Passes combination: E (even), A (even),
C (odd), G (even)

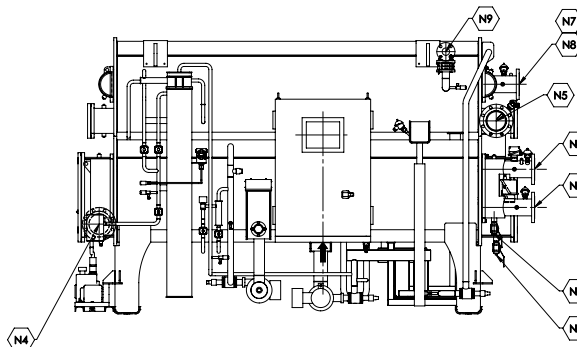

Passes combination: E (even), A (odd),
C (even), G (even)

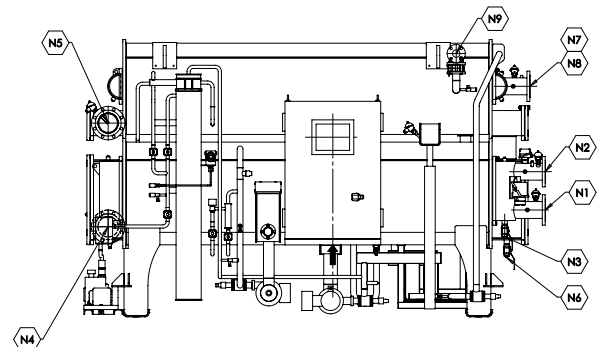

Passes combination: E (even), A (odd),
C (odd), G (even)

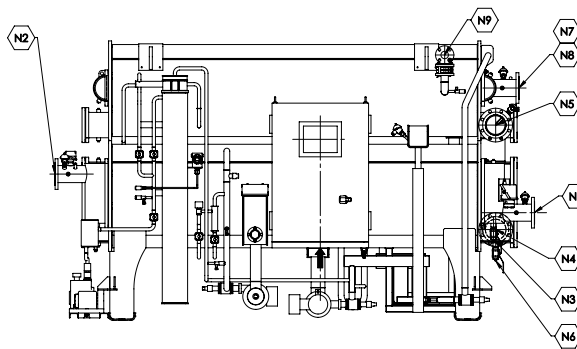

Passes combination: E (odd), A (even),
C (even), G (even)

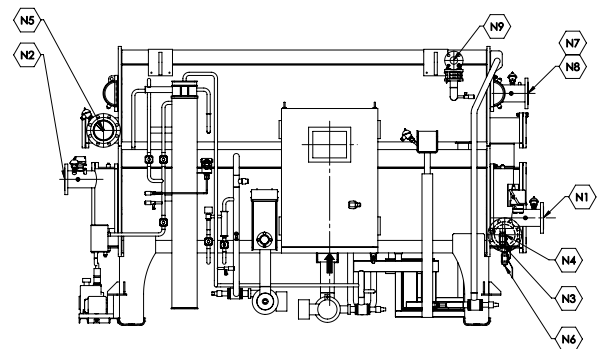

Passes combination: E (odd), A (even),
C (odd), G (even)

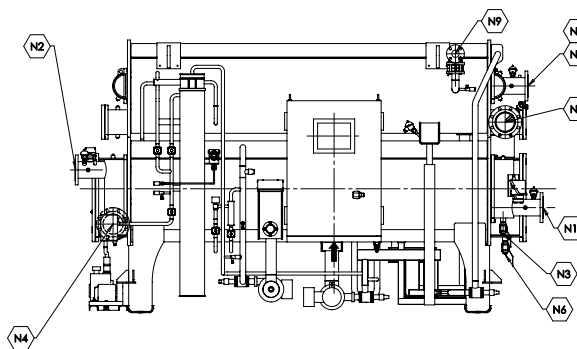

Passes combination: E (odd), A (odd),
C (even), G (even)

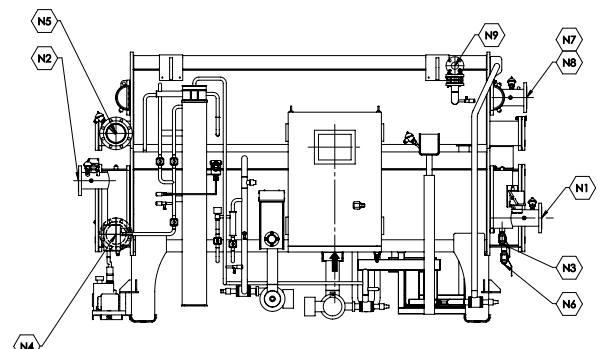

Passes combination: E (odd), A (odd),
C (odd), G (even)

4. 5G Small series



E = Evaporator, A = Absorber, C = Condenser, G = Generator

N1 = Chilled water inlet

N2 = Chilled water outlet

N3 = Chilled water drain

N4 = Cooling water inlet

N5 = Cooling water outlet

N6 = Cooling water drain

N7 = Hot water inlet

N8 = Hot water outlet

N9 = Rupture disk connection

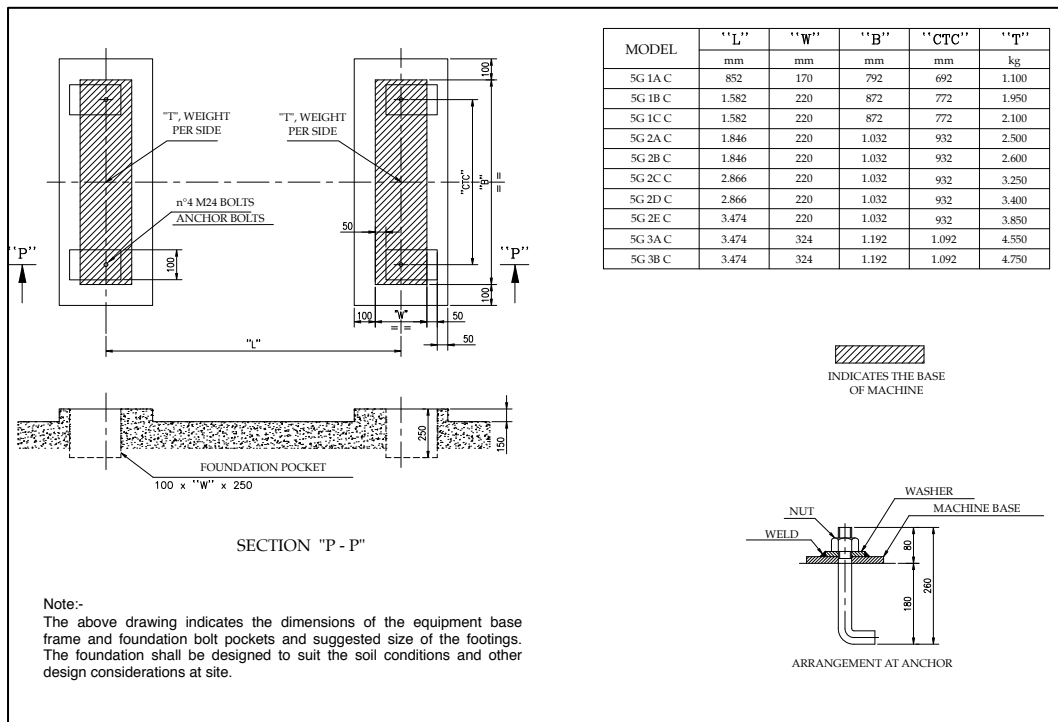

Foundation details

5G SMALL POSSIBLE APPLICATIONS:

- District heating/cooling
- Cogeneration/Trigeneration
- Food industry
- Automotive industry
- Solar cooling

NECESSARY DATA TO PREPARE AN OFFER

- Cooling capacity required (or alternatively the available heat capacity)
- Chilled water inlet/outlet temperatures
- Cooling water inlet/outlet temperatures
- Hot water inlet/outlet temperatures



A series of horizontal dotted lines for writing notes, with a large, faint watermark of the number '11' in the lower-left quadrant.



5G TWIN

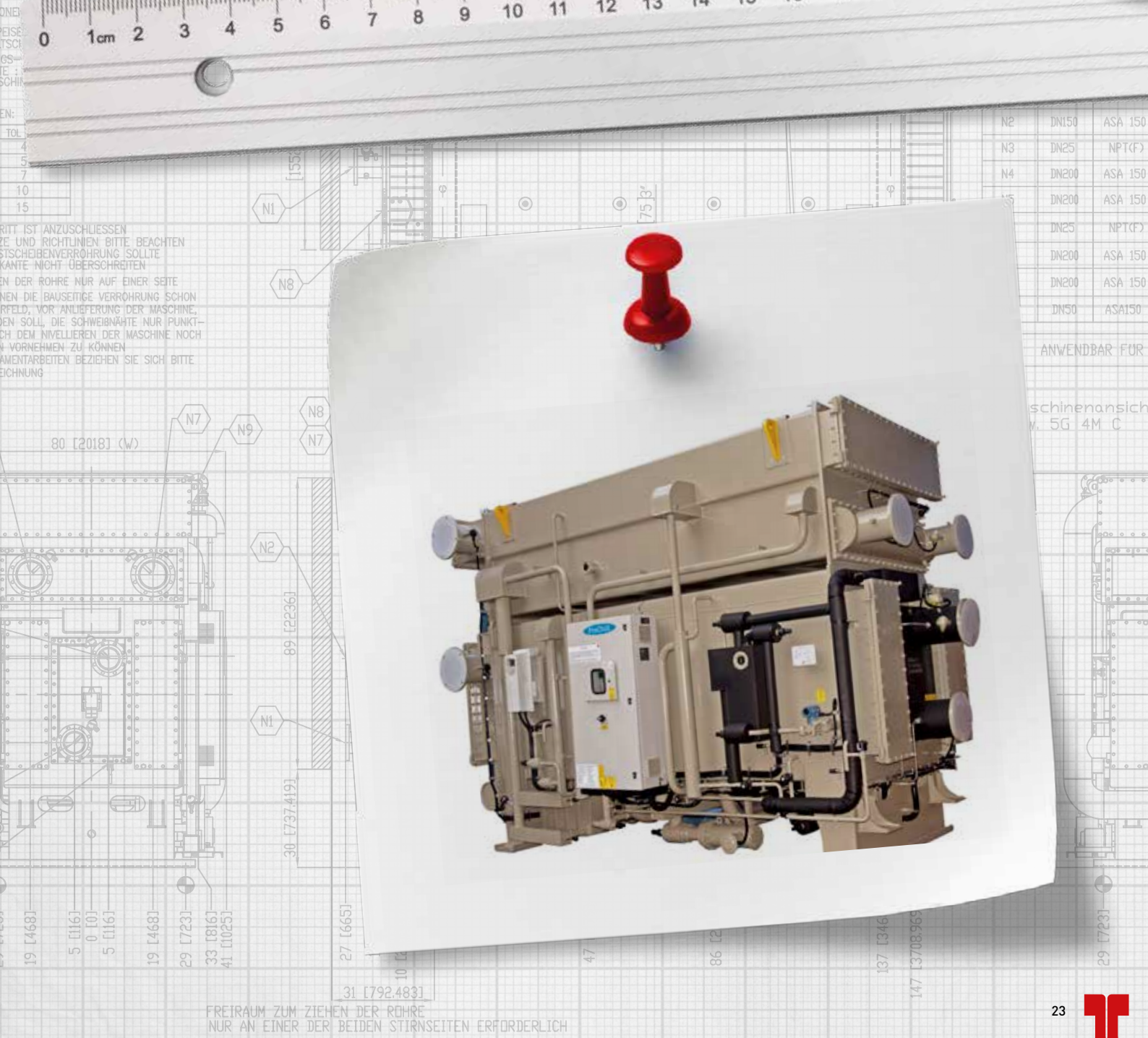
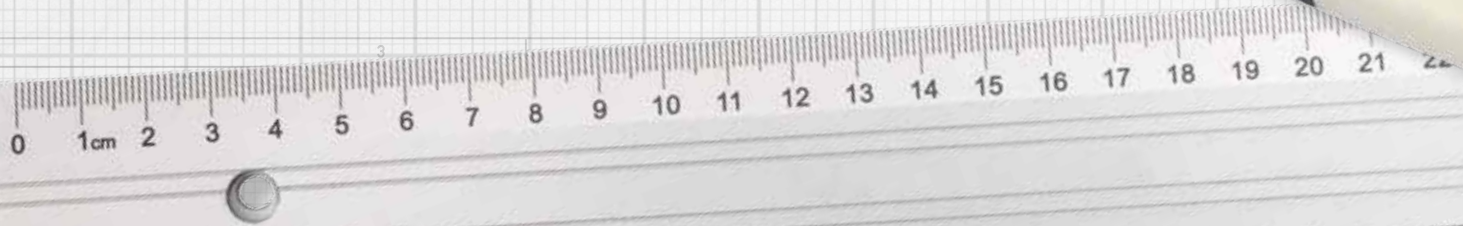
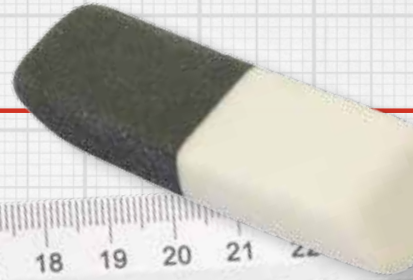

BRITT IST ANZUSCHLIESSEN
 UND RICHTLINIEN BITTE BEACHTEN
 STSCHEIBENVERROHRUNG SOLLTE
 KANTE NICHT ÜBERSCHREITEN
 EN DER ROHRE NUR AUF EINER SEITE
 NEN DIE BAUSEITIGE VERROHRUNG SCHON
 RFELD, VOR ANLIEFERUNG DER MASCHINE,
 EN SOLL, DIE SCHWEIßNÄHE NUR PUNKT-
 CH DEM NIVELLIEREN DER MASCHINE NOCH
 VORNEHMEN ZU KÖNNEN
 AMENTARBEITEN BEZIEHEN SIE SICH BITTE
 EICHNUNG

N2	DN150	ASA 150
N3	DN25	NPT(F)
N4	DN200	ASA 150
N5	DN200	ASA 150
	DN25	NPT(F)
	DN200	ASA 150
	DN200	ASA 150
	DN50	ASA150

ANWENDBAR FÜR
 schinenansich
 v. 5G 4M C

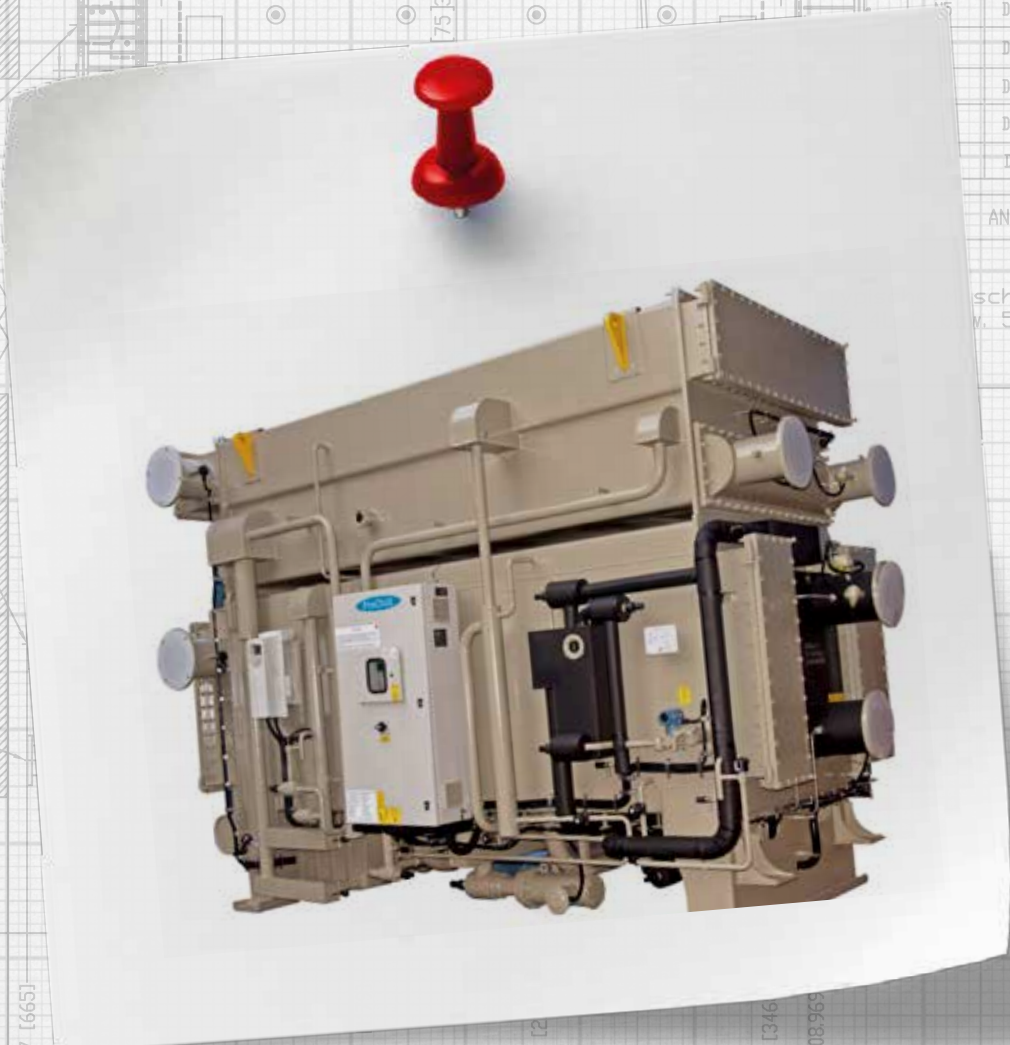

FREIRAUM ZUM ZIEHEN DER ROHRE
 NUR AN EINER DER BEIDEN STIRNSEITEN ERFORDERLICH



5. – 5G TWIN

Latest generation of single effect low temperature hot water fired absorption chillers. This series features a double stage evaporation/absorption technology.

The machines are specifically designed to be used with low temperature hot water, to maximize the efficiency and they are suitable to be used with high DT in water circuits.

This new generation of machines feature compact dimensions, easy to use, easy to maintenance and one of the highest efficiency of the market.

Cooling capacity from 780 kW to 5.500 kW.

Hot water inlet between 75 °C and 120 °C.

COP: between 0,75 and 0,80

In normal absorption chiller, capacity is decided by capacity achieved at maximum concentration that can be practically used without posing a danger of crystallization. Hence usually absorber is considered as most critical section. In hot water chillers where heat source temperatures are low, capacity is decided by maximum concentration that generator can achieve. Such concentrations are usually low and far away from crystallization concentration. Thus the generator becomes more critical than the absorber in many hot water chillers. At a given temperature lithium bromide concentration increases at lower pressure. Hence if generator is maintained at lower pressure higher concentration and higher capacity can be achieved. This is done by changing cooling water flow direction.

To facilitate lithium bromide boiling at low hot water temperature, either very high generator area is required or high cooling water flow is needed. Both are costly options. Hence TWIN type machines are introduced.

WORKING CYCLE.

By installing vertical plates in lower and upper shell two machines are housed in single machine.

Lithium bromide flows in both machines in parallel while hot, cooling and chilled water flow in series. Low pressure – low temperature generator supplies lithium bromide to high pressure absorber and high pressure – high temperature generator supply lithium bromide to low pressure absorber. High temperature generator can generate higher concentration, which can generate low pressure in absorber. Low absorber pressure facilitates low temperature chilled water. Low temperature generator can generate lower concentration. Such a lithium bromide has limited absorptivity. However this lithium bromide is used in high pressure absorber where chilled water temperatures are higher. This lithium bromide goes to high pressure absorber. At higher pressure absorptivity of lithium bromide improves. Thus effective use of concentrations and pressures can generate better capacity at same heat transfer area.

STANDARD FEATURES:

- Double shell design: the upper shell (including the condensers and the generators) and the lower shell (including the evaporators and the absorbers).
- The unique TWIN design feature helps to deliver high efficiencies with low hot water temperatures and can take higher temperature differences (DT). The TWIN design encompasses 2 separate cycles, each working at different lithium bromide concentrations and pressures, in order to optimise the heat



and mass transfer and maximize the efficiency.

- Split absorber construction, with evaporator sandwiched between absorbers. The cold surfaces to be insulated are drastically reduced.
- Straight tubes in the generators for easy maintenance.
- Gravity feed spraying technology in evaporator and absorber. Liquids are sprayed downwards on the tubes to ensure good film thickness and better heat transfer.
- Marine type headers in absorber and condenser.
- Crystallization control and prevention based on on-line determination of actual measured concentration.
- Refrigerant autoblowdown solenoid valve controlled by solution concentration
- Level electrodes for refrigerant level monitoring in the evaporator. (excluded model 5G 1A C)
- PLC based control panel SIEMENS SIMATIC S7-1200
- Alarm state annunciation through an audio signal and appropriate messages display on the operator interface terminal.
- Operator panel SIEMENS TP700, 7" touchscreen.
- MODBUS RTU connectivity as a standard feature.
- Several field interlocks available for plant automation.
- Mini-finned SS 430 Ti tubes in generator
- DLP copper tubes in evaporator, absorber and condenser.
- Crystallization prevention safeties: overflow pipe for auto decrystallisation, low/high cooling water inlet temperature cut-out, high temperature control for generator, hot water control valve PLC control based on generator temperature.
- PID algorithm capable of achieving part load operation from 10 to 100% stepless, based on chilled water outlet temperature.
- Purge system, which continuously and automatically removes non condensable gases from the shell side and stores them in a tank. A purge pump is provided as standard feature.
- Two regenerative heat exchanger to increase the efficiency of the cycle. The heat exchangers are plate type, with copper brazed stainless steel plates, designed for the maximum heat exchange with minimum pressure loss. The use of a plate heat exchanger ensures a compact design of the unit.
- Isolating valves for easy removal of the pumps for maintenance without breaking the vacuum inside the chiller.
- Antifreeze protection safeties: PLC inbuilt antifreeze alarm, antifreeze thermostat, low temperature cut-out for refrigerant pump (L-cut), flow switch and D.P. switch for chilled water.
- Completely factory assembled and wired.
- Potential free contacts for remote and automatic operation of the machine: chilled, cooling and hot water pumps start/stop, cooling tower fans start/stop, remote start/stop of the machine, remote indication of machine status (on/off) and machine trip, remote setpoint.
- Rupture disk
- Digital vacuum transmitter
- Insulation of cold surfaces.
- TRG, a patented bearing monitoring system for monitoring the wear and tear of the bearings (through contacts inside control panel).
- Inverter on solution pump



OPTIONAL:

- Special metallurgy for tubes (CuNi 95/5, CuNi 90/10, Stainless steel, Titanium).
- Tubesheet and headers cladding in case of use of bad quality water not suitable for carbon steel
- On line indication of healthiness of bearings of refrigerant and solution pump (on line TRG).
- Insulation of hot surfaces.
- Two pieces shipment: unit can be shipped in two pieces to be reassembled on site.
- Profibus connection.
- Ethernet or Modbus TCP/IP connection.
- Autopurge system for automatic purging of purge tank (electric or pneumatic).



5G Twin series absorption chiller

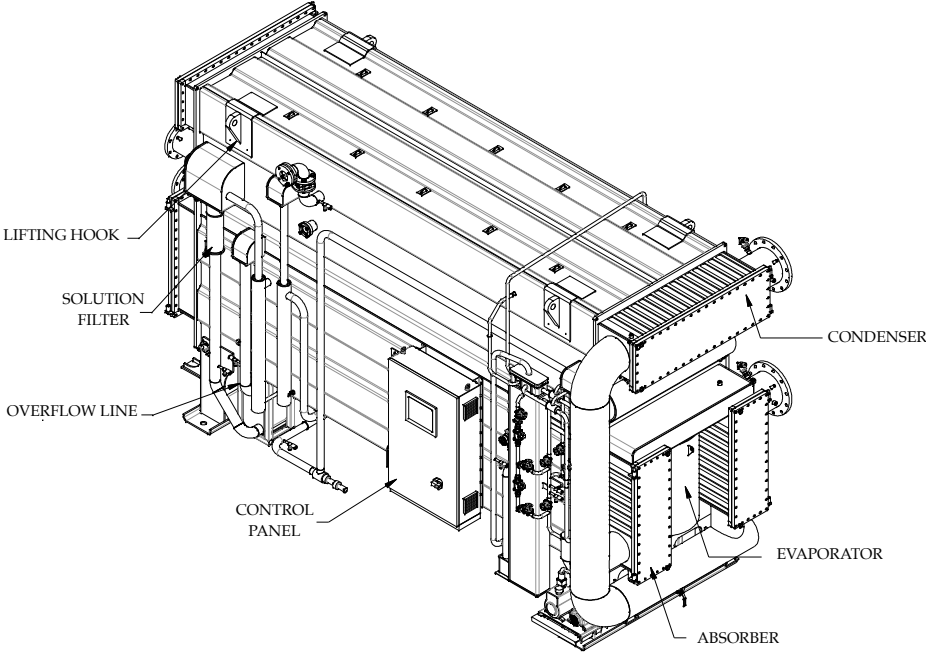

3D view of a 5G Twin machine with main components - Control panel side view

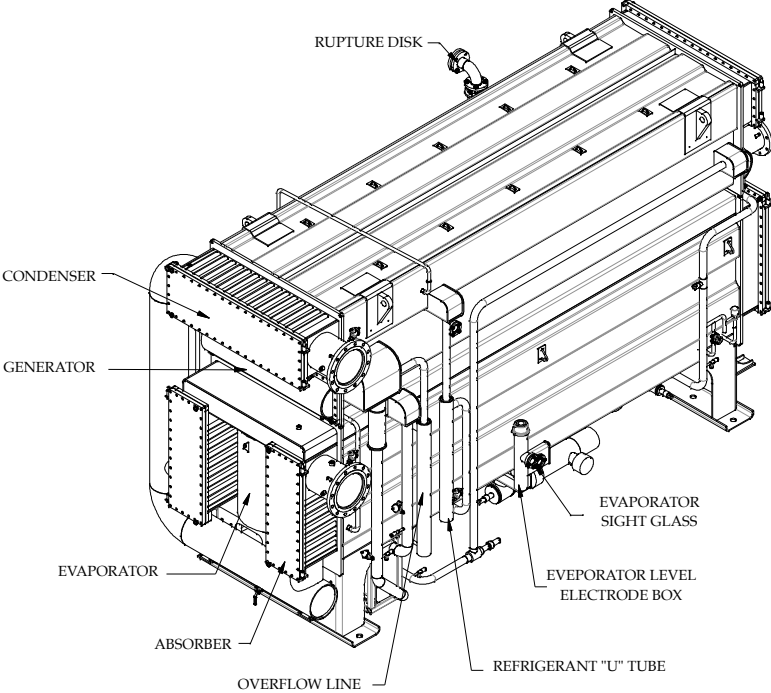

3D view of a 5G Twin machine with main components - Rear view



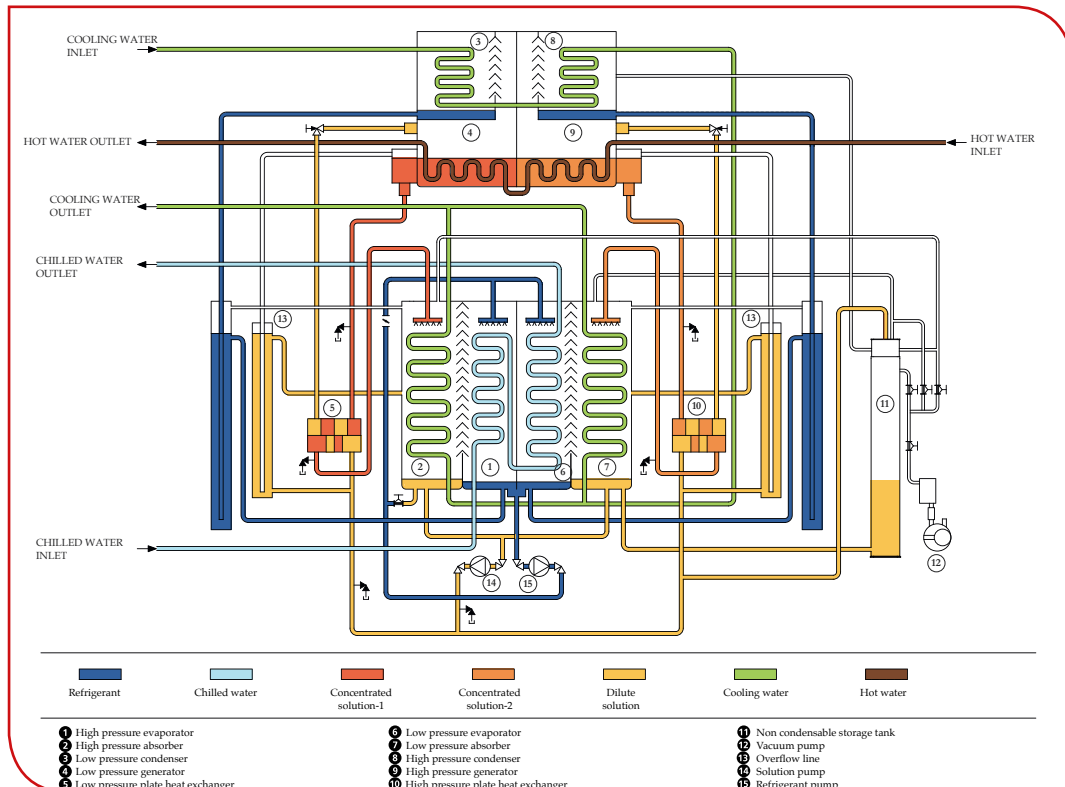

5G Twin working cycle

		UNITS	5G 3L C	5G 3M C	5G 4K C	5G 4L C	5G 4M C	5G 5K C	5G 5L C	5G 5M C	5G 5N C	5G 6K C	5G 6L C	5G 7K C	5G 7L C	5G 7M C	5G 8K C	5G 8L C	5G 8M C	5G 8N C	
Cooling capacity		kW	790	940	1059	1205	1295	1475	1625	1785	1955	2395	2625	3070	3295	3610	4120	4440	4775	5135	
	Chilled water	Flow	m ³ /h	135,5	161,2	181,6	206,7	222,1	253	278,7	306,2	335,3	410,8	450,2	526,6	565,2	619,2	706,7	761,5	819	880,7
	Connection diameter	DN	150			200			250			300			350			400			
Cooling water	Flow	m ³ /h	310	358	402	463	464	556	612	556	612	940	1.038	1.040	1.117	1.232	1.516	1.603	1.516	1.603	
	Temperature in/out	°C	29-34	29-34,2	29-34,2	29-34,1	29-34,5	29-34,2	29-34,2	29-35,3	29-35,3	29-34	29-34	29-34,8	29-34,8	29-34,8	29-34,4	29-34,5	29-35,2	29-35,3	
	Connection diameter	DN	200			250			300			350			400						
Hot water	Flow	m ³ /h	89,5	107	120,8	137	147	167	184	203	223	271	299	346	372	408	465	501	540	582	
	Connection diameter	DN	150			200			250			300			350						
Dimensions	Length (L)	mm	4010	4620	4670		4750		5930		7380		7390		7520		8770				
	Width (W)	mm	1920	1920	2040		2220		2290		2430		2850		3170		3170				
	Height (H)	mm	2860	2860	3060		3220		3330		3400		3660		3900		3900				
Weights	Shipping weight	x1000 kg	10,1	11,2	12,9	13,3	13,6	15,4	15,8	18,5	19,1	24,5	25,2	32,2	32,9	33,9	39,7	40,9	45,3	46,6	
	Working weight	x1000 kg	11,9	13,3	15,4	16,0	16,5	18,9	19,6	22,9	23,7	29,9	30,9	40,1	41,2	42,7	50,6	52,2	57,4	59,4	
Clearance	Clearance for tube removal	mm	3700			4300			5340			6700			6910			8220			
Electrical data	Solution pump	kW(A)	1,5 (5,0)		3,7 (11,0)		3,7 (11,0)		5,5 (14,0)		6,6 (17)		4,5 (13,0)		5,5 (17)						
	Refrigerant pump	kW(A)	0,3 (1,4)			1,5 (5,0)			1,5 (5,0)												
	Vacuum pump	kW(A)	0,75 (1,8)																		
	Power consumption	kVA	6,9		11,2		11,2		13,4		18,1		15,2		18,1						
Power supply	415 V (±10 %), 50 Hz (±5 %), 3 Phase+N																				

1) Model code: 5G XX - C low temperature hot water fired absorption chiller, 2) Inlet/Outlet chilled water temperature = 12/7 °C, 3) Inlet/Outlet cooling water temperature = see above table, 4) Inlet/Outlet hot water temperature = 90°C/80°C, 5.a) Fouling factors: chilled water and hot water - 0,018 m²-K/kW, b) Fouling factor cooling water - 0,044m²-K/kW, 6) Minimum chilled water outlet temperature 3,5°C; lower temperatures upon request, 7) Minimum cooling water inlet temperature 18 °C, 8) Plantroom minimum/maximum temperature 5-45 °C, 9) Maximum working pressure in water circuits = 8 bar(g); higher pressures available upon request at extra price, 10) Please contact Thermax representative/office for customised specifications.



NOZZLES ORIENTATION DEPENDING ON NUMBER OF PASSES:

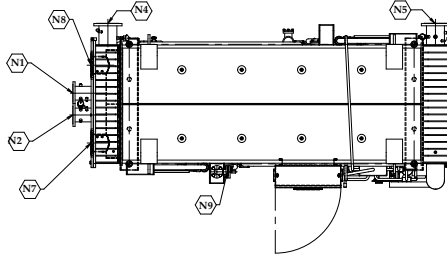
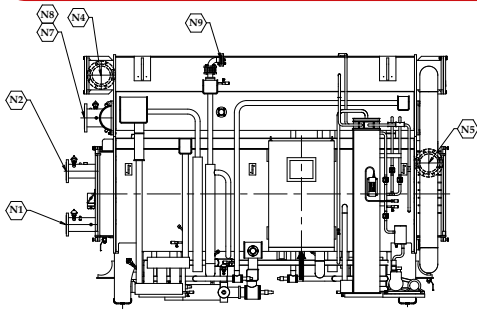

Passes combination: E (1+1), A (even,even), C (1,1), G (1+1)

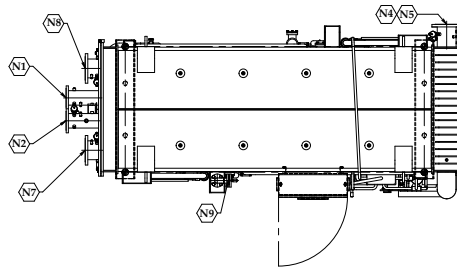
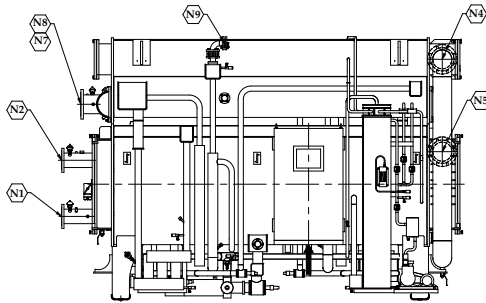

Passes combination: E (1+1), A (even,even), C (1+1), G (1+1)

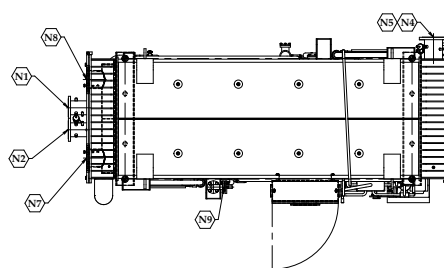
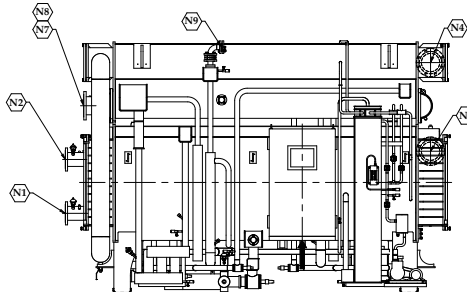

Passes combination: E (1+1), A (odd,odd), C (1,1), G (1+1)

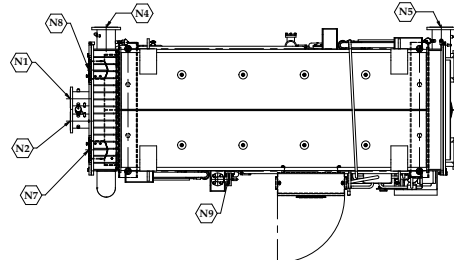
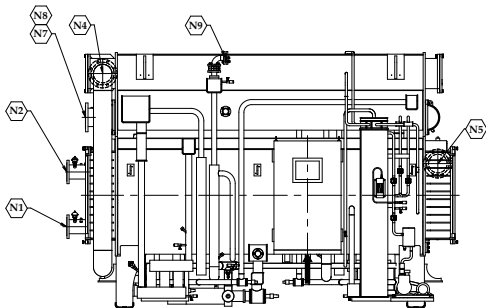

Passes combination: E (1+1), A (odd,odd), C (1+1), G (1+1)

E=Evaporator, A=Absorber, C=Condenser, G=Generator

N1 = Chilled water inlet

N3 = Chilled water drain

N5 = Cooling water outlet

N7 = Hot water inlet

N9 = Rupture disk connection

N2 = Chilled water outlet

N4 =Cooling water inlet

N6 = Cooling water drain

N8 = Hot water outlet



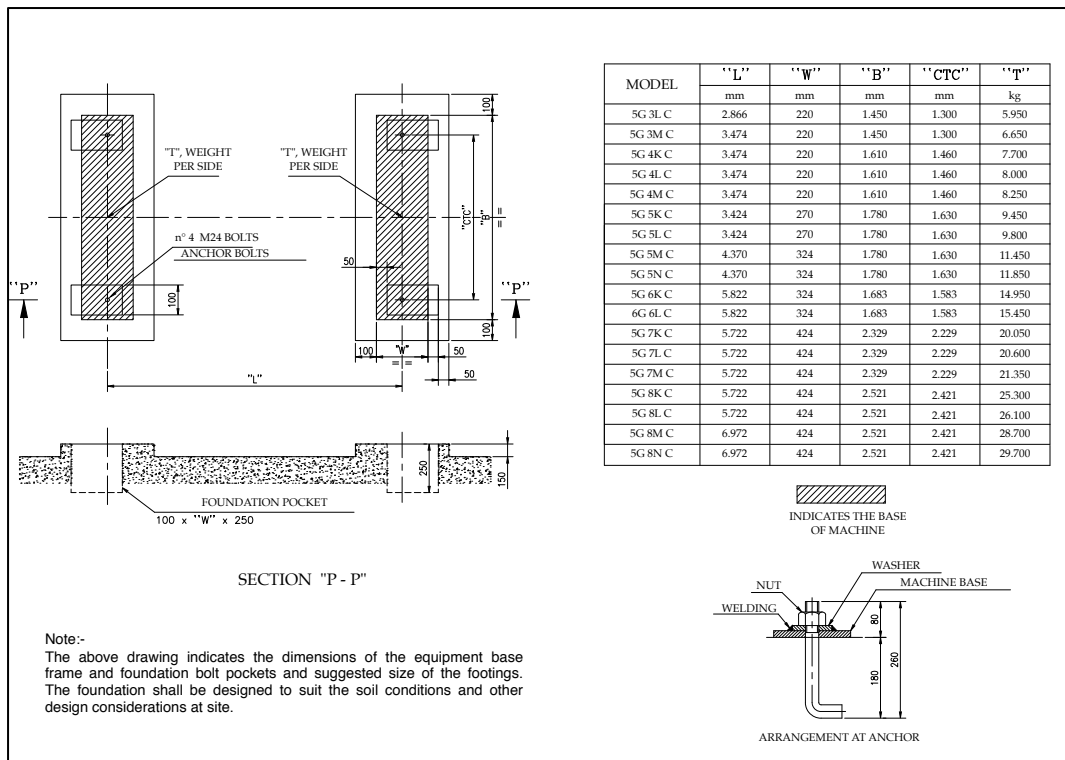

Foundation details

5G TWIN POSSIBLE APPLICATIONS:

- District heating/cooling
- Cogeneration/Trigeneration
- Food industry
- Automotive industry
- Solar cooling

NECESSARY DATA TO PREPARE AN OFFER

- Cooling capacity required (or alternatively the available heat capacity)
- Chilled water inlet/outlet temperatures
- Cooling water inlet/outlet temperatures
- Hot water inlet/outlet temperatures



HD 10, SD 10, ED 10 & GD 10 series

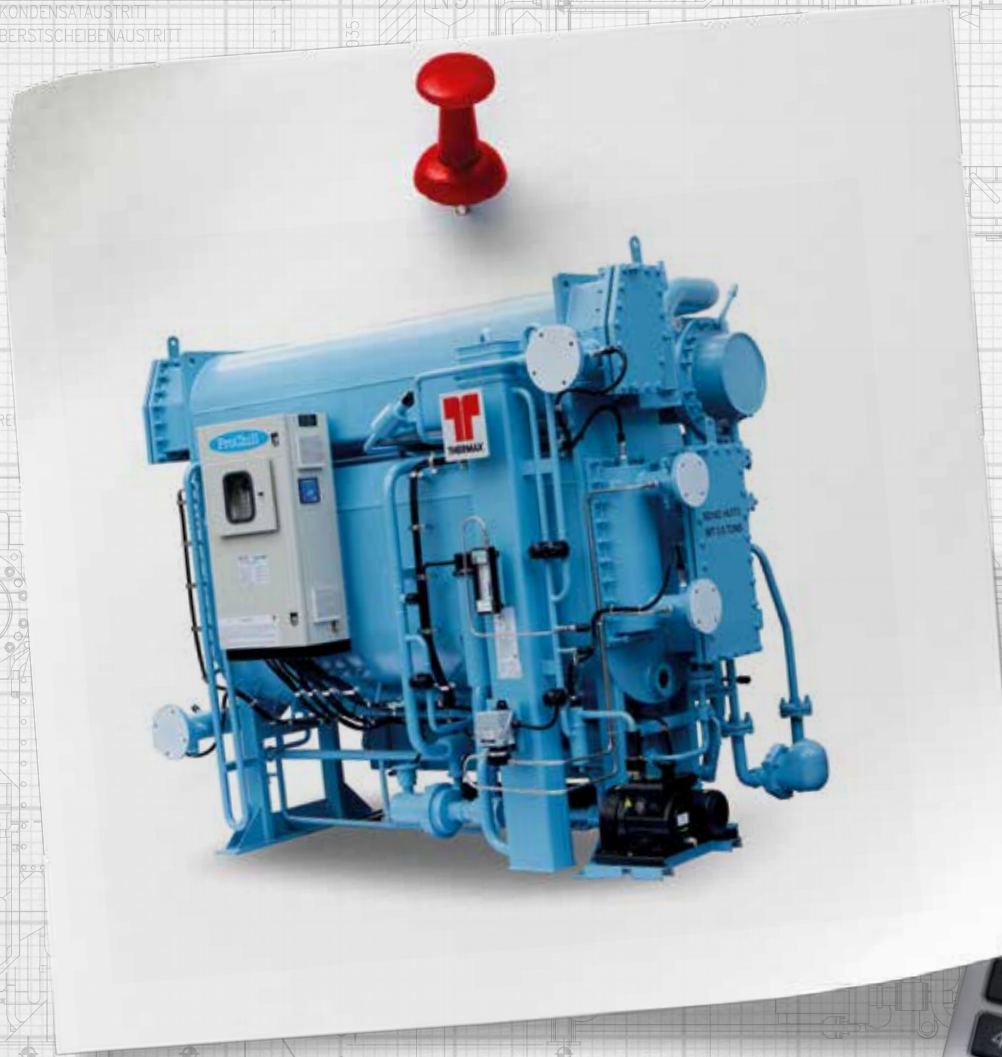
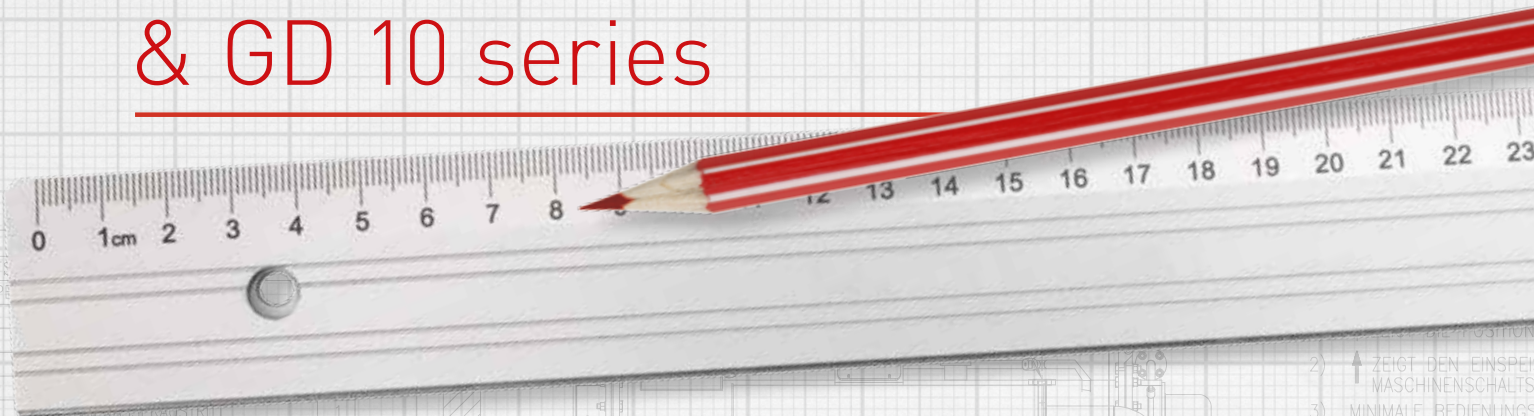

- 2) ↑ ZEIGT DEN EINSPERIGEN MASCHINENSCHALTSTANDORT AN
 - 3) MINIMALE BEDIENUNGS- UND WARTUNGSSCHWELLEN SOLLTEN ÜBER DER MASCHINEN-OBERKANTE LIEGEN
ANDERE : 500
 - 4) MASCHINENTOLERANZEN
- | L (MTR) | T (MTR) |
|---------|---------|
| 0-3 | 0-3 |
| 3-5 | 3-5 |
| 5-7 | 5-7 |
| 7-10 | 7-10 |
| OVER 10 | OVER 10 |
- 5) BERSTSCHIBENAUSSTRITZSOLLTEN DIE LOKALEN GESETZE ÜBER DIE BAUSEITIGE BERSTSCHIBENAUSSTRITZSOLLTEN DIE MASCHINEN-OBERKANTE ÜBERSCHEITEN
 - 6) FREIRÄUME ZUM ZIEHEN DER RÖHRE SOLLTEN WEITESTGEHEND IM VORFELD ABGESCHLOSSEN WERDEN
 - 7) IN DEN FÄLLEN IN DENEN KEINE KORREKTURMAßNAHMEN ZUM ZUSCHWEIßEN, UM NACH DER MONTAGE KORREKTURMAßNAHMEN ZUM ZUSCHWEIßEN, UM NACH DER MONTAGE
 - 8) BEZÜGLICH DER FUNDAMENTIERUNG SOLLTEN AUF DIE FUNDAMENTIERUNG

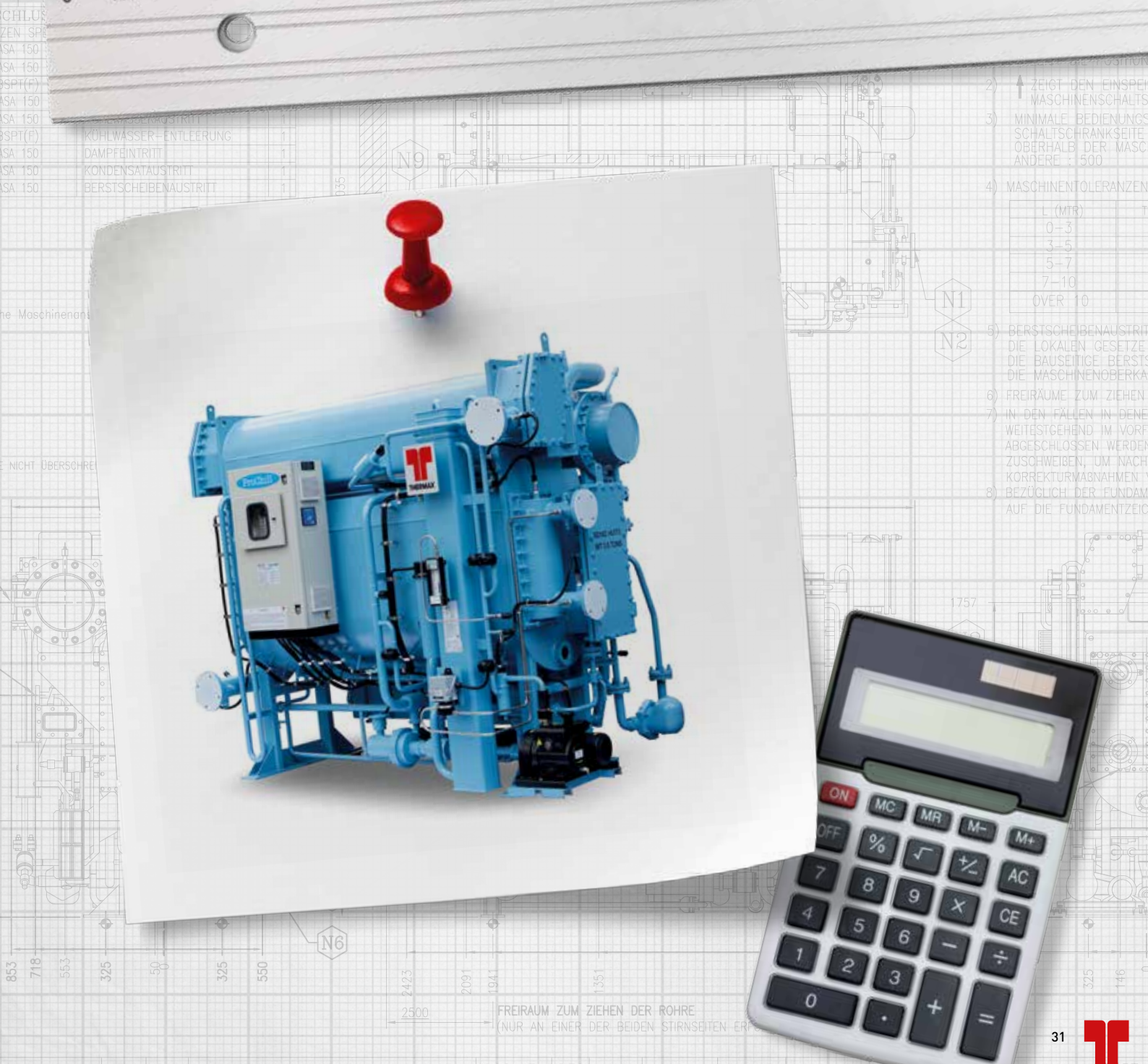

FREIRaum ZUM ZIEHEN DER RÖHRE
(NUR AN EINER DER BEIDEN STIRNSEITEN ERFORDERLICH)



6. HD 10, SD 10, ED 10 E GD 10:

Small size double effect absorption chillers, steam fired (SD 10), superheated water fired (HD 10), exhaust gases fired (ED 10) and natural gas fired (GD 10).

The steam and superheated water fired machines are specifically designed to be used with dry saturated steam at 8 bar(g) or high temperature superheated water (180°C is the design value).

This range of machines feature compact dimensions, easy to use, easy to maintenance and one of the highest efficiency of the market.

Cooling capacity from 165 kW to 355 kW.

Superheated water inlet temperature between 155 °C and 180 °C, steam pressure between 6 bar (g) and 10 bar (g), exhaust gases inlet temperature between 350°C and 600°C .

COP: between 1,25 and 1,35

STANDARD FEATURES:

- Triple shell design: the upper shell (including condenser and low temperature generator(LTG)), the lower shell (including evaporator and the absorber) and High temperature Generator(HTG).
- Straight tubes in the HTG for easy maintenance
- Gravity feed spraying technology in evaporator and absorber. Liquids are sprayed downwards on the tubes to ensure good film thickness and better heat transfer.
- Crystallization control and prevention based on on-line determination of actual measured concentration.
- Refrigerant autoblowdown solenoid valve controlled by solution concentration
- Level electrodes for refrigerant and solution level monitoring in the evaporator, absorber and high temperature generator.
- PLC based control panel SIEMENS SIMATIC S7-1200
- Alarm state annunciation through an audio signal and appropriate messages display on the operator interface terminal.
- Operator panel SIEMENS TP700, 7" touchscreen.
- MODBUS RTU connectivity as a standard feature.
- Several field interlocks available for plant automation.
- High temperature generator tubes in stainless steel SS430 (SD 10 and HD 10) or in boiler grade carbon steel (ED 10 and GD 10).
- DLP copper tubes in evaporator, absorber and condenser.
- All headers are of Carbon steel (evaporator, absorber, condenser), fully removable from either side, for an easy access to the tube bundle. All water boxes have flanged connections.
- Hi-Low gas burner (GD 10).
- Crystallization prevention safeties: overflow pipe for auto decrystallisation, low/high cooling water inlet temperature cut-out, high temperature control for generator, steam/hot water control valve/exhaust damper PLC control based on generator temperature.
- PID algorithm capable of achieving part load operation from 10 to 100% stepless, based on chilled water outlet temperature.

- Purge system, which continuously and automatically removes non condensable gases from the shell side and stores them in a tank. A purge pump is provided as standard feature.
- Three (HD 10, GD 10 or ED 10) or four (SD 10) regenerative heat exchanger to increase the efficiency of the cycle. The heat exchangers are plate type, with copper brazed stainless steel plates, designed for the maximum heat exchange with minimum pressure loss. The use of a plate heat exchanger ensures a compact design of the unit.
- Isolating valves for easy removal of the pumps for maintenance without breaking the vacuum inside the chiller.
- Antifreeze protection safeties: PLC inbuilt antifreeze alarm, antifreeze thermostat, low temperature cut-out for refrigerant pump (L-cut), flow switch and D.P. switch for chilled water.
- Completely factory assembled and wired.
- Potential free contacts for remote and automatic operation of the machine: chilled and cooling water pumps start/stop, cooling tower fans start/stop, remote start/stop of the machine, remote indication of machine status (on/off) and machine trip, remote setpoint.
- Rupture disk
- Digital vacuum transmitter
- TRG, a patented bearing monitoring system for monitoring the wear and tear of the bearings (through contacts inside control panel)

OPTIONAL:

- Special metallurgy for tubes (CuNi 95/5, CuNi 90/10, Stainless steel, Titanium).
- Tubesheet and headers cladding in case of use of bad quality water not suitable for carbon steel
- On line indication of healthiness of bearings of refrigerant and solution pump (on line TRG).
- Insulation of cold and hot surfaces (excluded surfaces at T higher than 150°C).
- Three pieces shipment: unit can be shipped in three pieces to be reassembled on site: lower shell, upper shell and HTG.
- Profibus connection.
- Ethernet or Modbus TCP/IP connection.
- Autopurge system for automatic purging of purge tank (electric or pneumatic).
- Modulating burner (GD 10)

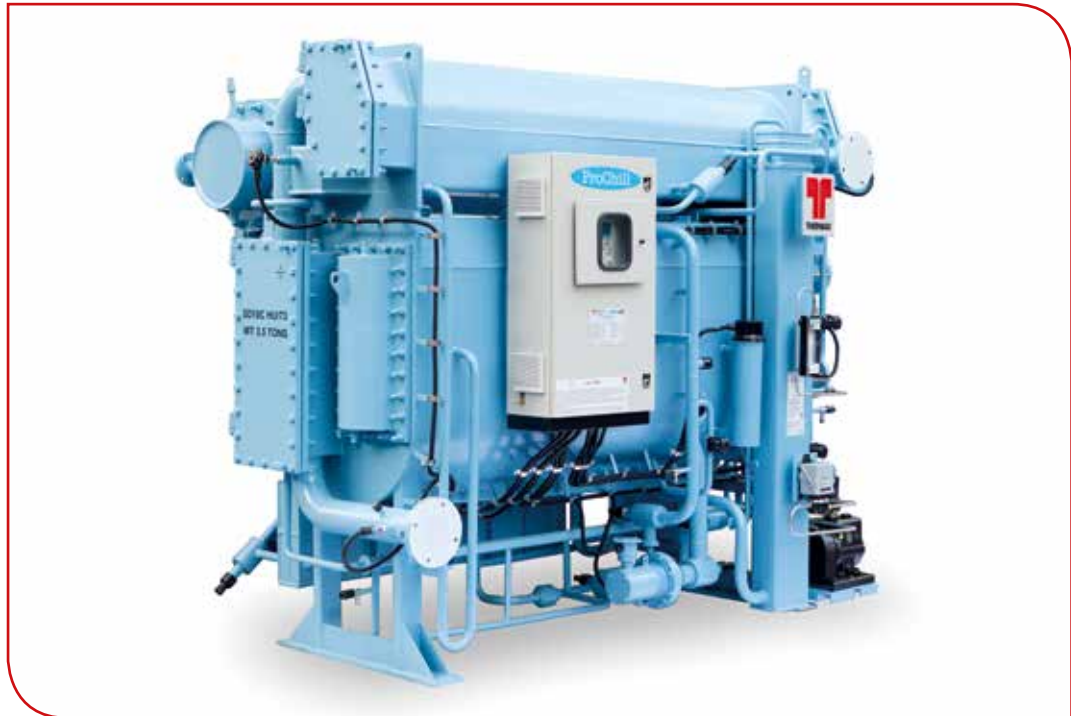

Double effect absorption chiller SD 10 series

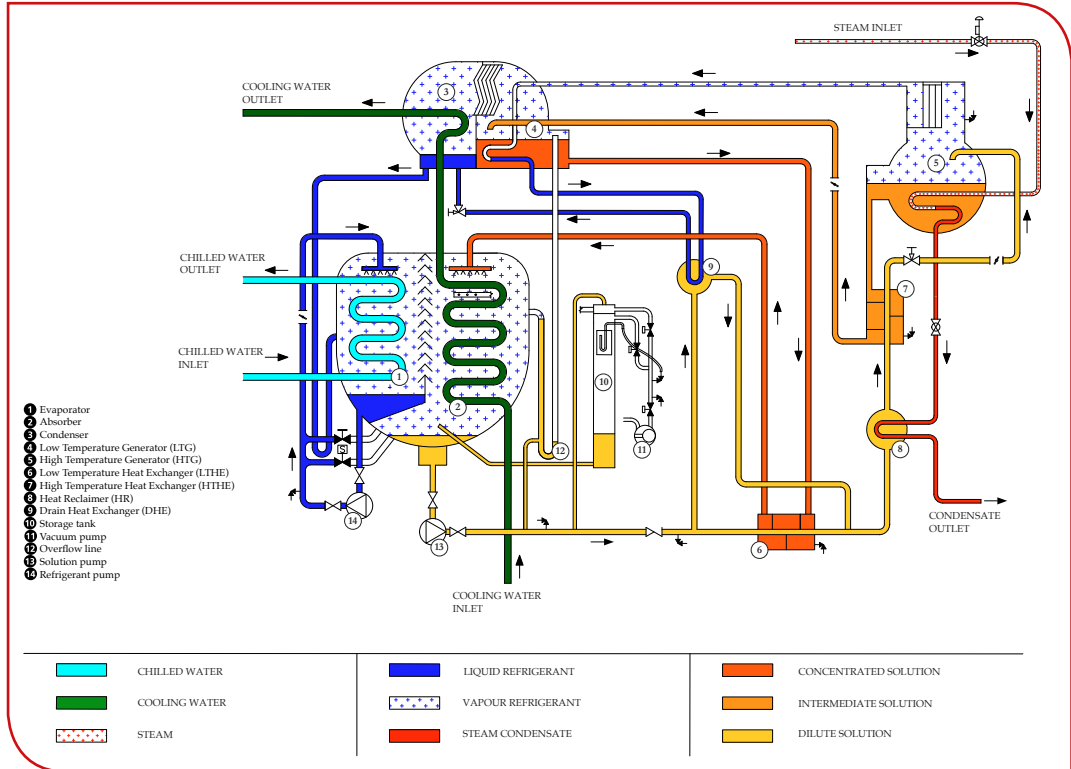

Working cycle of SD 10 series

Working cycles of HD, ED and GD machines differ only for the HTG side, where heat source is varying. Heat reclaimer is present only in SD 10 machines.

6. HD10, SD10, ED10, GD10 series



		UNITS	SD10A CU	SD10B CU	SD10C CU
Cooling capacity		kW	172	267	366
Chilled water	Flow	m ³ /h	29,6	45,9	62,8
	Connection diameter	DN		80	
Cooling water	Flow	m ³ /h	53,5	83,0	112,4
	Connection diameter	DN		100	
Steam	Flow	kg/h	204,0	316,0	432,0
	Connection diameter (Steam)	DN		40	
	Connection diameter (Condensate)	DN		25	
Dimensions	Length (L)	mm	2550	2860	
	Width (W)	mm	1375	1595	
	Height (H)	mm	2020	2235	
Weights	Shipping weight	x1000kg	3,4	3,9	4,1
	Working weight	x1000kg	3,7	4,4	4,6
Clearance	Clearance for tube removal	mm	2200	2500	2500
Electrical data	Solution pump	kW(A)		1,1 (3,4)	
	Refrigerant pump	kW(A)		0,3 (1,4)	
	Vacuum pump	kW(A)		0,75 (1,8)	
	Power consumption	kVA		5,7	
	Power supply			415 V (±10 %), 50 Hz (±5 %), 3 Phase+N	

1) Model code: SD 10 X CU steam fired double effect absorption chiller, 2) Inlet/Outlet chilled water temperature = 12/7 °C, 3) Inlet/Outlet cooling water temperature = 29-34°C, 4) Steam pressure: 8 bar (g), 5.a) Fouling factors: chilled water - 0,018 m²-K/kW, b) Fouling factors: cooling water - 0,044m²-K/kW, 6) Minimum chilled water outlet temperature 3,5°C; lower temperatures upon request, 7) Minimum cooling water inlet temperature 20 °C, 8) Plantroom minimum/maximum temperature 5-45 °C, 9) Maximum working pressure in water circuits = 8 bar(g); higher pressures available upon request at extra price, 10) Maximum working pressure of steam circuit: 10,5 bar (g), 11) Please contact Thermax representative/office for customised specifications.

		UNITS	ED10A CU	ED10B CU	ED10C CU
Cooling capacity		kW	172	267	366
Chilled water	Flow	m ³ /h	29,6	45,9	62,8
	Connection diameter	DN		80	
Cooling water	Flow	m ³ /h	52,5	81,5	112
	Connection diameter	DN		100	
Exhaust gases	Heat input	kW	146,1	226,4	310
Dimensions	Length (L)	mm	2600	2900	
	Width (W)	mm	1850	2025	
	Height (H)	mm	2100	2300	
Weights	Shipping weight	x1000kg	4,1	4,5	4,7
	Working weight	x1000kg	4,5	5,0	5,2
Clearance	Clearance for tube removal	mm	2200	2500	2500
Electrical data	Solution pump	kW(A)		1,1 (3,4)	
	Refrigerant pump	kW(A)		0,3 (1,4)	
	Vacuum pump	kW(A)		0,75 (1,8)	
	Power consumption	kVA		5,7	
	Power supply			415 V (±10%), 50 Hz (±5 %), 3 Phase+N	

1) Model code: ED 10 X CU exhaust gases fired double effect absorption chiller, 2) Inlet/Outlet chilled water temperature = 12/7 °C, 3) Inlet/Outlet cooling water temperature = 29-34°C, 4) Exhaust gases inlet temperature between 350°C and 600°C; Minimum exhaust gases outlet temperature = 170°C, 5.a) Fouling factors: chilled water - 0,018 m²-K/kW, b) Fouling factors: cooling water - 0,044m²-K/kW, 6) Minimum chilled water outlet temperature 3,5°C; lower temperatures upon request, 7) Minimum cooling water inlet temperature 20 °C, 8) Plantroom minimum/maximum temperature 5-45 °C, 9) Maximum working pressure in water circuits = 8 bar(g); higher pressures available upon request at extra price, 10) Please contact Thermax representative/office for customised specifications.

		UNITS	GD10A CU	GD10B CU	GD10C CU
Cooling capacity		kW	172	267	366
Chilled water	Flow	m ³ /h	29,6	45,9	62,8
	Connection diameter	DN		80	
Cooling water	Flow	m ³ /h	52,5	81,5	112
	Connection diameter	DN		100	
Gas circuit	Gas consumption	m ³ /h	14,0	21,6	29,6
	Stack connection diameter	DN		100	125
Dimensions	Length (L)	mm	2550	2860	
	Width (W)	mm	1800	1985	
	Height (H)	mm	2100	2300	
Weights	Shipping weight	x1000kg	4,0	4,4	4,6
	Working weight	x1000kg	4,4	4,9	5,1
Clearance	Clearance for tube removal	mm	2200	2500	2500
Electrical data	Solution pump	kW(A)		1,1 (3,4)	
	Refrigerant pump	kW(A)		0,3 (1,4)	
	Vacuum pump	kW(A)		0,75 (1,8)	
	Burner	kW(A)		0,4 (2,6)	
	Power consumption	kVA		7,5	
	Power supply			415 V (±10 %), 50 Hz (±5 %), 3 Phase+N	

1) Model code: GD 10 X CU gas fired double effect absorption chiller, 2) Inlet/Outlet chilled water temperature = 12/7 °C, 3) Inlet/Outlet cooling water temperature = 29-34°C, 4) Gross calorific value of gas = 37.683 kJ/Nm³, 5.a) Fouling factors: chilled water - 0,018 m²-K/kW, b) Fouling factors: cooling water - 0,044m²-K/kW, 6) Minimum chilled water outlet temperature 3,5°C; lower temperatures upon request, 7) Minimum cooling water inlet temperature 20 °C, 8) Plantroom minimum/maximum temperature 5-45 °C, 9) Maximum working pressure in water circuits = 8 bar(g); higher pressures available upon request at extra price, 10) Please contact Thermax representative/office for customised specifications.

		UNITS	HD10A CU	HD10B CU	HD10C CU
Cooling capacity		kW	172	267	366
Chilled water	Flow	m ³ /h	29,6	45,9	62,8
	Connection diameter	DN		80	
Cooling water	Flow	m ³ /h	52,5	81,5	112
	Connection diameter	DN		100	
Superheated water	Flow	m ³ /h	12,2	18,9	25,9
	Connection diameter	DN		50	
Dimensions	Length (L)	mm	2550	2860	
	Width (W)	mm	1375	1595	
	Height (H)	mm	2020	2235	
Weights	Shipping weight	x1000kg	3,5	4,0	4,2
	Working weight	x1000kg	3,8	4,5	4,7
Clearance	Clearance for tube removal	mm	2200	2500	2500
Electrical data	Solution pump	kW(A)		1,1 (3,4)	
	Refrigerant pump	kW(A)		0,3 (1,4)	
	Vacuum pump	kW(A)		0,75 (1,8)	
	Power consumption	kVA		5,7	
	Power supply			415 V (±10%), 50 Hz (±5 %), 3 Phase+N	

1) Model code: HD 10 X CU superheated water fired double effect absorption chiller, 2) Inlet/Outlet chilled water temperature = 12/7 °C, 3) Inlet/Outlet cooling water temperature = 29-34°C, 4) Inlet/Outlet superheated water = 175/165°C, 5.a) Fouling factors: chilled water - 0,018 m²-K/kW, b) Fouling factors: cooling water - 0,044m²-K/kW, 6) Minimum chilled water outlet temperature 3,5°C; lower temperatures upon request, 7) Minimum cooling water inlet temperature 20 °C, 8) Plantroom minimum/maximum temperature 5-45 °C, 9) Maximum working pressure in water circuits = 8 bar(g); higher pressures available upon request at extra price, 10) Maximum working pressure of superheated water circuit: 10,5 bar (g), 11) Please contact Thermax representative/office for customised specifications.



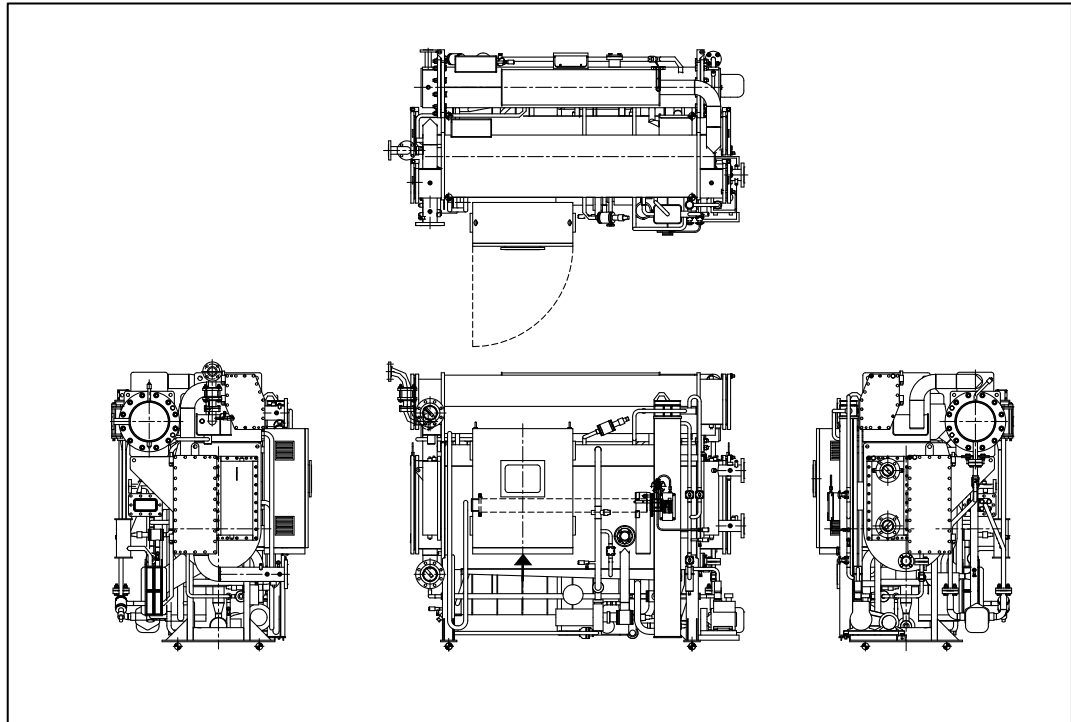

Typical layout of SD 10 machine

MODEL	"L"	"W"	"B"	"CTC"	"T"
	mm	mm	mm	mm	kg
SD/HD 10A CU	1.672	130	900	650	1.900
SD/HD 10B CU	1.941	130	900	650	2.250
SD/HD 10C CU	1.941	130	900	650	2.350

SECTION "P - P"

Note:
The above drawing indicates the dimensions of the equipment base frame and foundation bolt pockets and suggested size of the footings. The foundation shall be designed to suit the soil conditions and other design considerations at site.

Foundation details for SD10/HD 10 machines



10 SERIES POSSIBLE APPLICATIONS:

- District heating/cooling
- Cogeneration/Trigeneration
- Food industry
- Automotive industry
- Solar cooling
- Steam from turbines discharge

NECESSARY DATA TO PREPARE AN OFFER

- Cooling capacity required (or alternatively the available heat capacity)
- Chilled water inlet/outlet temperatures
- Cooling water inlet/outlet temperatures
- Superheated water inlet/outlet temperatures (HD 10)
- Available steam pressure (SD 10)
- Exhaust gases temperature and flow (ED 10)
- Allowable Pressure drop in exhaust furnace (ED 10)



A series of horizontal dotted lines for writing notes, with a large, faint watermark of the number '11' in the lower-left quadrant.

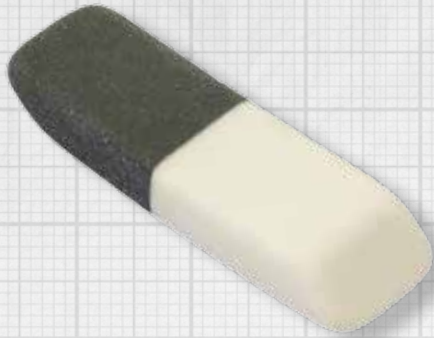

HS/SS series

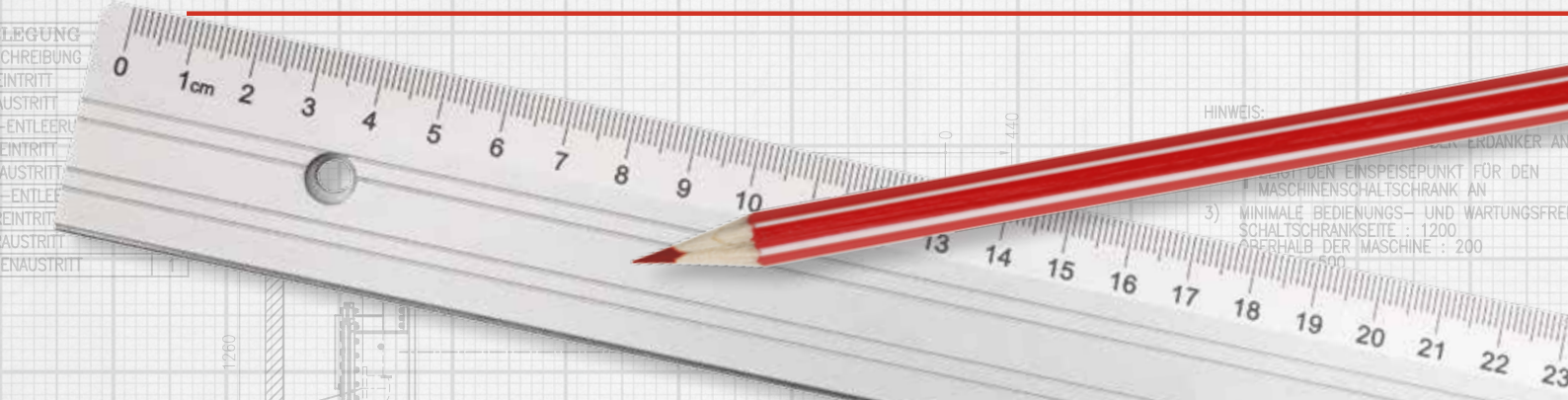

LEGUNG
SCHREIBUNG
EINTRITT
AUSTRITT
ENTLEERUNG
EINTRITT
AUSTRITT
ENTLEERUNG
EINTRITT
AUSTRITT
ENAUSRITT

HINWEIS:
... DEN EINSPEISEPUNKT FÜR DEN
MASCHINENSCHALTSCHRANK AN
3) MINIMALE BEDIENUNGS- UND WARTUNGSFREIE
SCHALTSCHRANKSEITE : 1200
OBERHALB DER MASCHINE : 200
... 500

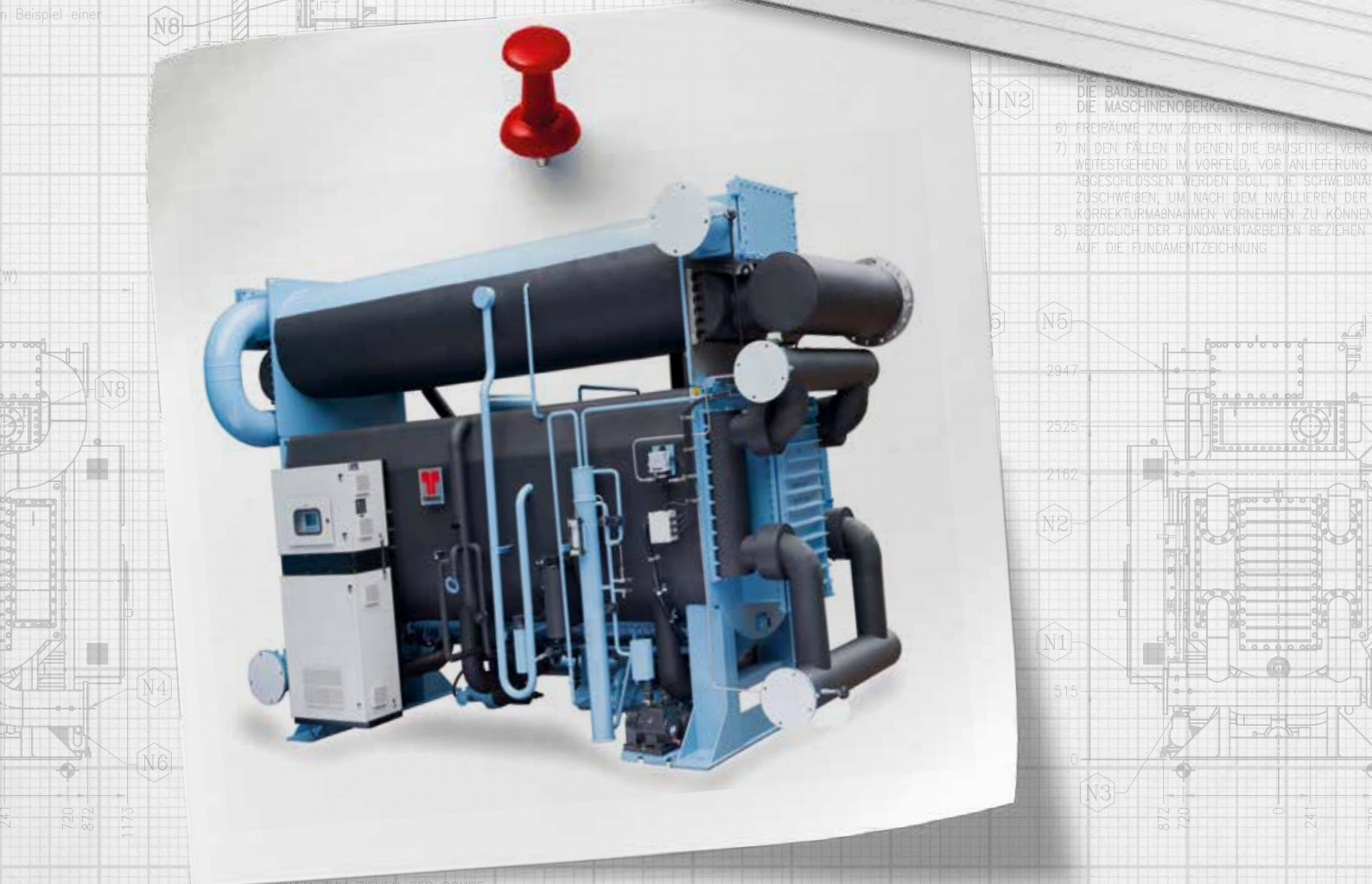

N1 N2
6) FREIRÄUME ZUM ZIEHEN DER RÖHRE (NUR AN EINER DER BEIDEN STIRNSEITEN ERFORDERLICH)
7) IN DEN FÄLLEN IN DENEN DIE BAUSEITIGE VERRÜHRUNG ABGESCHLOSSEN WERDEN SOLL, DIE SCHWEIßNÄHE ZUSCHWEIßEN, UM NACH DEM NIVELLIEREN DER KORREKTURMAßNAHMEN VORNEHMEN ZU KÖNNEN
8) BEZÜGLICH DER FUNDAMENTARBEITEN BEZIEHEN AUF DIE FUNDAMENTZEICHNUNG

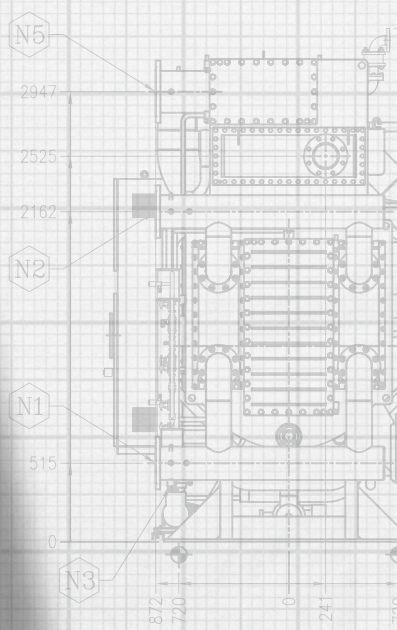

FREIRÄUM ZUM ZIEHEN DER RÖHRE (NUR AN EINER DER BEIDEN STIRNSEITEN ERFORDERLICH)



7. HS/SS SERIES:

Single effect medium temperature superheated water fired (HS) or steam fired (SS) absorption chillers.

The machines are specifically designed to be used with medium temperature superheated water or with low pressure steam.

Cooling capacity from 350 kW to 7.000 kW (higher capacities available upon request).

Superheated water inlet temperature between 115 °C and 150 °C.

Steam pressure between 0,5 bar (g) and 3,5 bar (g).

Steam pressure as low as 0,2 bar (g) for special applications available upon request

COP: between 0,7 and 0,72

STANDARD FEATURES:

- Double shell design: the upper shell (including condenser and generator), the lower shell (including evaporator and the absorber).
- "Split" type evaporator: the evaporator is divided into two different tube bundles, placed on both sides of the absorber, that remains in the middle of the two evaporators. This solution grants a better efficiency at part load, optimizing the mass transfer inside the solution.
- Straight tubes in the generators for easy maintenance.
- Gravity feed spraying technology in evaporator and absorber. Liquids are sprayed downwards on the tubes to ensure good film thickness and better heat transfer.
- Marine type headers at one side of absorber and condenser, for an easy access to the tube bundle without need of lifting systems to support the header. All water boxes have flanged connections. All water boxes are provided with drain and vent connections.
- Crystallization control and prevention based on on-line determination of actual measured concentration.
- Refrigerant autoblowdown solenoid valve controlled by solution level in absorber
- Level electrodes for refrigerant and solution level monitoring in the evaporator and absorber.
- PLC based control panel SIEMENS SIMATIC S7-1200
- Alarm state annunciation through an audio signal and appropriate messages display on the operator interface terminal.
- Operator panel SIEMENS TP700, 7" touchscreen.
- MODBUS RTU connectivity as a standard feature.
- Several field interlocks available for plant automation.
- Mini-finned SS 430 Ti tubes in generator
- DLP copper tubes in evaporator, absorber and condenser.
- Crystallization prevention safeties: overflow pipe for auto decrystallisation, low/high cooling water inlet temperature cut-out, high temperature control for generator, hot water/steam control valve PLC control based on generator temperature.

- PID algorithm capable of achieving part load operation from 10 to 100% stepless, based on chilled water outlet temperature.
- Purge system, which continuously and automatically removes non condensable gases from the shell side and stores them in a tank. A purge pump is provided as standard feature.
- Regenerative heat exchanger to increase the efficiency of the cycle. The heat exchanger is plate type, with copper brazed stainless steel plates, designed for the maximum heat exchange with minimum pressure loss. The use of a plate heat exchanger ensures a compact design of the unit.
- Heat reclaimer to recover heat from steam condensate (SS)
- Isolating valves for easy removal of the pumps for maintenance without breaking the vacuum inside the chiller.
- Antifreeze protection safeties: PLC inbuilt antifreeze alarm, antifreeze thermostat, low temperature cut-out for refrigerant pump (L-cut), flow switch and D.P. switch for chilled water.
- Completely factory assembled and wired.
- Potential free contacts for remote and automatic operation of the machine: chilled and cooling water pumps start/stop, cooling tower fans start/stop, remote start/stop of the machine, remote indication of machine status (on/off) and machine trip.
- Rupture disk
- Digital vacuum transmitter
- Inverter on solution pump.
- TRG, a patented bearing monitoring system for monitoring the wear and tear of the bearings (through contacts inside control panel)

OPTIONAL:

- Stand by refrigerant and solution pumps.
- Special metallurgy for tubes (CuNi 95/5, CuNi 90/10, Stainless steel, Titanium).
- Tubesheet and headers cladding in case of use of bad quality water not suitable for carbon steel
- On line indication of healthiness of bearings of refrigerant and solution pump (on line TRG).
- Insulation of cold and hot surfaces.
- Two pieces shipment: unit can be shipped in two pieces to be reassembled on site.
- Profibus connection.
- Ethernet or Modbus TCP/IP connection.
- Autopurge system for automatic purging of purge tank (electric or pneumatic).



Steam fired chiller of SS series

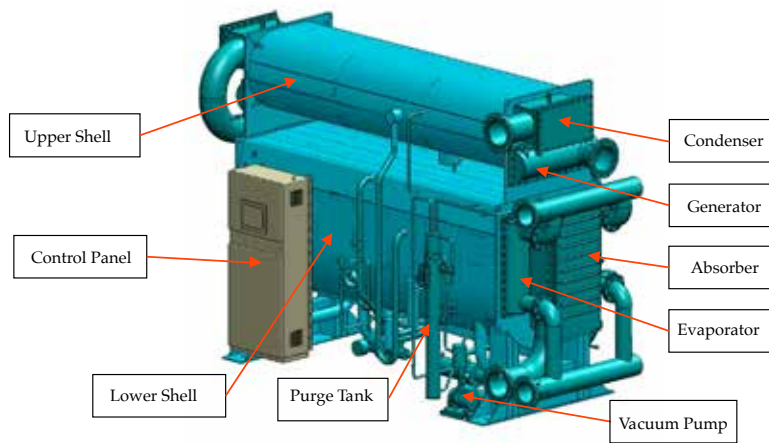

3D view of an SS machine with main components - Control panel side view

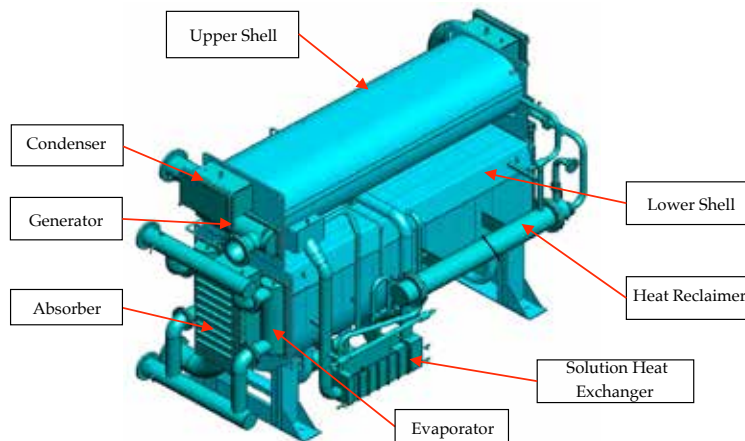

3D view of an SS machine with main components - Rear view

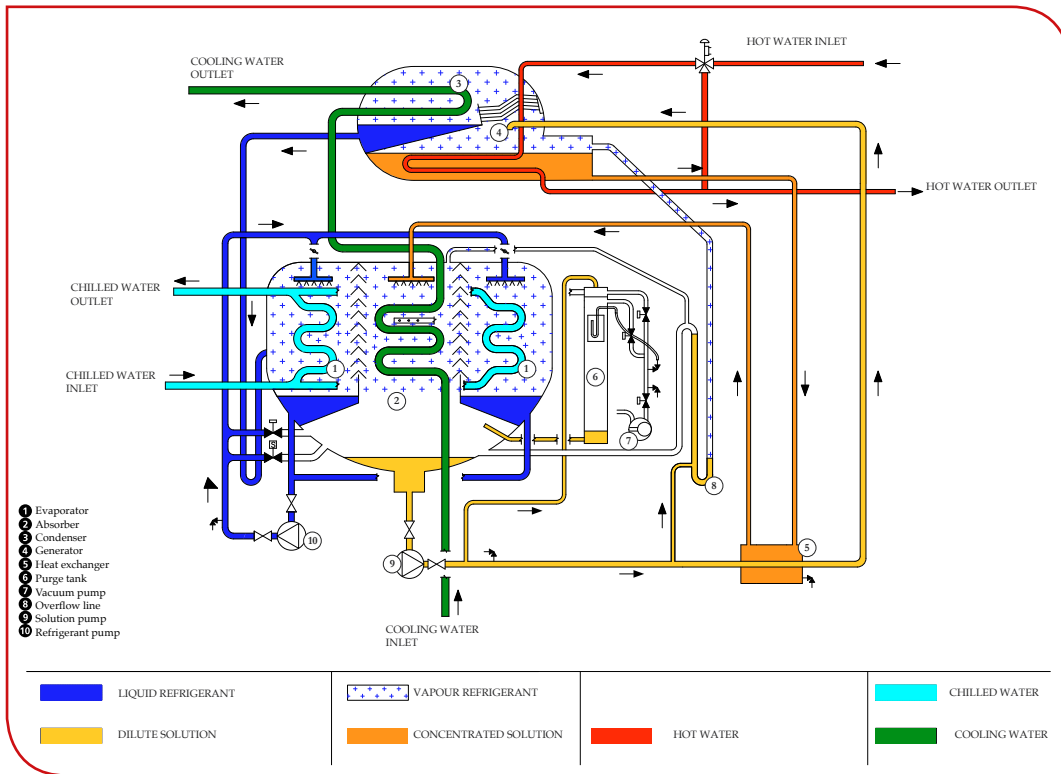

Working cycle of HS machine

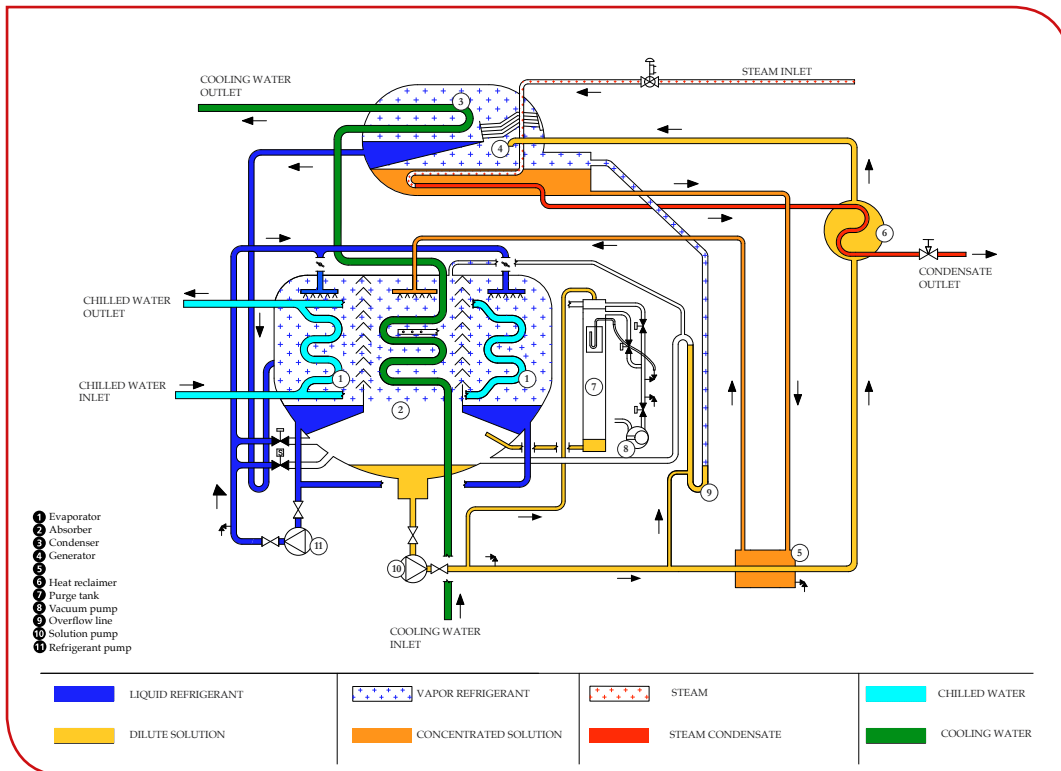

Working cycle of SS machine



7. HS/SS series

		UNITS	SS 20A CU	SS 20B CU	SS 20C CU	SS 20D CU	SS 30A CU	SS 30B CU	SS 30C CU	SS 40A CU	SS 40B CU	SS 40C CU	SS 50A CU	SS 50B CU	SS 60A CU	SS 60B CU	SS 60C CU	SS 60D CU	SS 70A CU	SS 70B CU	SS 80A CU	SS 80B CU	SS 80C CU	SS 80D CU											
Cooling capacity		kW	469	563	710	850	1.025	1.150	1.370	1.550	1.755	1.920	2.180	2.280	2.705	2.995	3.305	3.660	4.192	4.670	5.195	5.690	6.680	7.200											
Chilled water	Flow	m ³ /h	80,4	96,6	121,8	145,8	175,8	197,2	235	265,9	301	329,3	373,9	391,1	464	513,7	566,9	627,8	719	801	891	975,9	1.146	1.235											
	Connection diameter	DN	125				150				200				250				300				350				400								
Cooling water	Flow	m ³ /h	115	139	174	210	250	281	335	377	427	469	532	555	658	729	805	894	1.030	1.140	1.260	1.390	1.645	1.762											
	Connection diameter	DN	150				200				250				300				350				400												
Steam	Flow	kg/hr	1.022	1.236	1.533	1.849	2.209	2.485	2.978	3.330	3.774	4.165	4.697	4.913	5.822	6.452	7.135	7.927	9.017	10028	11127	12203	14436	15481											
	Connection diameter (Steam)	DN	150				200				250				300				350				400				450								
	Connection diameter (Condensate)	DN	40				50				65				80				100																
Dimensions	Length (L)	mm	2970			4000			4130			4740			4930			5050			6590			7880			7950			8630			9870		
	Width (W)	mm	1980			2020			2300			2325			2470			2670			2780			2730			2960			3600					
	Height (H)	mm	2830				2940				3325				3400				3825				4190				4690								
Weights	Shipping weight	x1000kg	4,9	5,0	5,9	6,1	7,6	7,8	8,6	10,8	11,1	11,4	13,1	13,3	19,4	19,8	22,2	22,9	29,2	29,8	38,6	39,0	43,3	43,8											
	Working weight	x1000kg	5,4	5,6	6,6	6,8	8,6	8,9	9,8	12,5	12,9	13,2	15,3	15,7	22,5	23,1	25,8	26,7	34,0	34,9	45,6	46,3	51,2	52,0											
Clearance	Clearance for tube removal	mm	2600			3600			3700			4200			4250			4400			5700			6900			6900			7000			8300		
Electrical data	Solution pump	kW(A)	1,1 (3,4)		1,5 (5,0)		3,0 (8,0)		3,7 (11,0)		3,7 (11,0)		5,5 (14,0)		6,6 (17,0)		4,5 (13,0)		4,5 (13,0)		5,5 (17,0)														
	Refrigerant pump	kW(A)	0,3 (1,4)								1,5 (5,0)																								
	Vacuum pump	kW(A)	0,75 (1,8)																																
	Power consumption	kVA	5,7		6,9		9,1		11,2		11,2		13,4		18,1		15,2		15,2		18,1														
	Power supply		415 V (±10 %), 50 Hz (±5%), 3 Phase+N																																

1) Model code: SS XXX - CU single effect steam fired absorption chiller, 2) Inlet/Outlet chilled water temperature = 12/7 °C, 3) Inlet/Outlet cooling water temperature = 29/37,5°C 4) Steam pressure = 1,5 bar (g), 5.a) Fouling factors: chilled water - 0,018 m²-K/kW, b) Fouling factor cooling water - 0,044m²-K/kW, 6) Minimum chilled water outlet temperature 3,5°C; lower temperatures upon request, 7) Minimum cooling water inlet temperature 10 °C, 8) Plantroom minimum/maximum temperature 5-45 °C, 9) Maximum working pressure in water circuits = 8 barg; higher pressures available upon request at extra price, 10) Please contact Thermax representative/office for customised specifications.

		UNITS	HS 20A CU	HS 20B CU	HS 20C CU	HS 20D CU	HS 30A CU	HS 30B CU	HS 30C CU	HS 40A CU	HS 40B CU	HS 40C CU	HS 50A CU	HS 50B CU	HS 60A CU	HS 60B CU	HS 60C CU	HS 60D CU	HS 70A CU	HS 70B CU	HS 80A CU	HS 80B CU	HS 80C CU	HS 80D CU											
Cooling capacity		kW	469	563	710	850	1.025	1.150	1.370	1.550	1.755	1.920	2.180	2.280	2.705	2.995	3.305	3.660	4.192	4.670	5.195	5.690	6.680	7.200											
Chilled water	Flow	m ³ /h	80,4	96,6	121,8	145,8	175,8	197,2	235	265,9	301	329,3	373,9	391,1	464	513,7	566,9	627,8	719	801	891	975,9	1.146	1.235											
	Connection diameter	DN	125				150				200				250				300				350				400								
Cooling water	Flow	m ³ /h	116	140	176	210	252	284	342	382	432	474	536	559	664	738	815	904	1.030	1.148	1.268	1.394	1.645	1.768											
	Connection diameter	DN	150				200				250				300				350				400												
Superheated water	Flow	m ³ /h	31	37,2	46,8	56	67,1	75,2	90,4	101,3	114,4	126,2	142,4	149,3	176,4	196,1	217,4	240,8	273,3	304,4	337,8	370,1	436,4	469,5											
	Connection diameter	DN	150				200				250				300				350				400				450								
Dimensions	Length (L)	mm	2970			4000			4130			4740			4930			5050			6590			7880			7950			8630			9870		
	Width (W)	mm	1980			2020			2300			2325			2470			2670			2780			2730			2960			3600					
	Height (H)	mm	2830				2940				3325				3400				3825				4190				4690								
Weights	Shipping weight	x1000kg	4,9	5,0	5,9	6,1	7,6	7,8	8,6	10,8	11,1	11,4	13,1	13,3	19,4	19,8	22,2	22,9	29,2	29,8	38,6	39,0	43,3	43,8											
	Working weight	x1000kg	5,4	5,6	6,6	6,8	8,6	8,9	9,8	12,5	12,9	13,2	15,3	15,7	22,5	23,1	25,8	26,7	34,0	34,9	45,6	46,3	51,2	52,0											
Clearance	Clearance for tube removal	mm	2600			3600			3700			4200			4250			4400			5700			6900			6900			7000			8300		
Electrical data	Solution pump	kW(A)	1,1 (3,4)		1,5 (5,0)		3,0 (8,0)		3,7 (11,0)		3,7 (11,0)		5,5 (14,0)		6,6 (17,0)		4,5 (13,0)		4,5 (13,0)		5,5 (17,0)														
	Refrigerant pump	kW(A)	0,3 (1,4)								1,5 (5,0)																								
	Vacuum pump	kW(A)	0,75 (1,8)																																
	Power consumption	kVA	5,7		6,9		9,1		11,2		11,2		13,4		18,1		15,2		15,2		18,1														
	Power supply		415 V (±10 %), 50 Hz (±5%), 3 Phase+N																																

1) Model code: HS XXX - CU single effect superheated water fired absorption chiller, 2) Inlet/Outlet chilled water temperature = 12/7 °C, 3) Inlet/Outlet cooling water temperature = 29/37,5°C 4) Inlet/Outlet superheated water = 150/130°C, 5.a) Fouling factors: chilled water - 0,018 m²-K/kW, b) Fouling factor cooling water - 0,044m²-K/kW, 6) Minimum chilled water outlet temperature 3,5°C; lower temperatures upon request, 7) Minimum cooling water inlet temperature 10°C, 8) Plantroom minimum/maximum temperature 5-45 °C, 9) Maximum working pressure in water circuits = 8 barg; higher pressures available upon request at extra price, 10) Please contact Thermax representative/office for customised specifications.

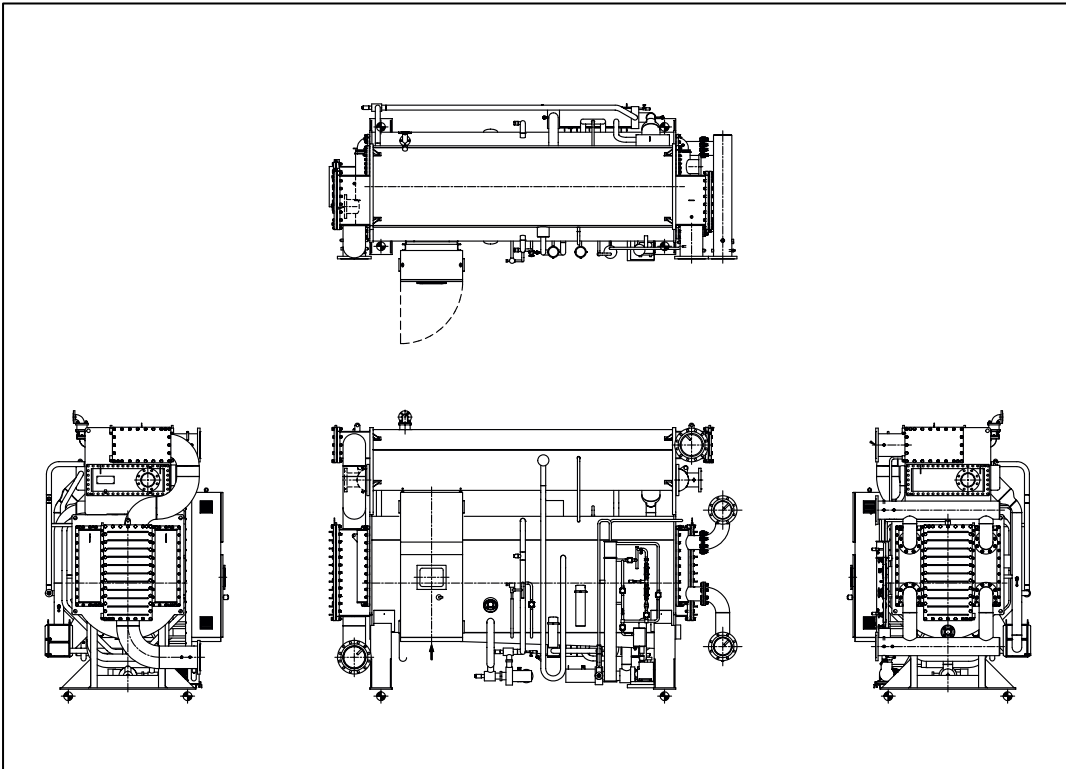

Typical layout of HS machine

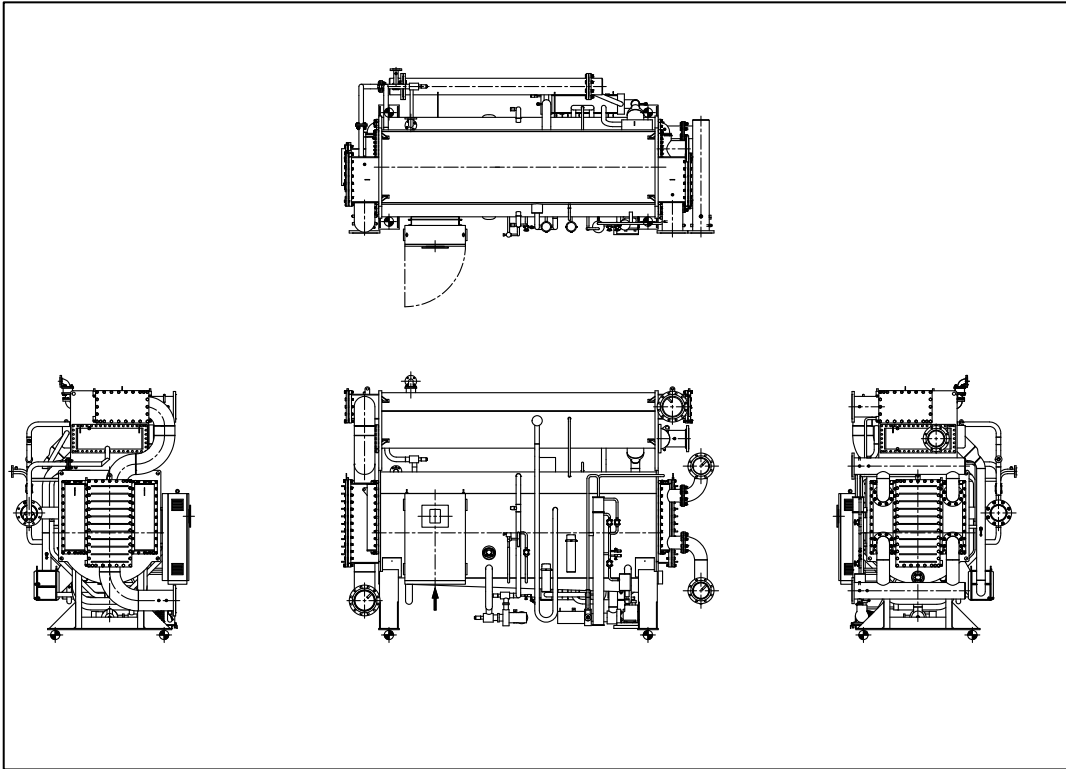

Typical layout of SS machine



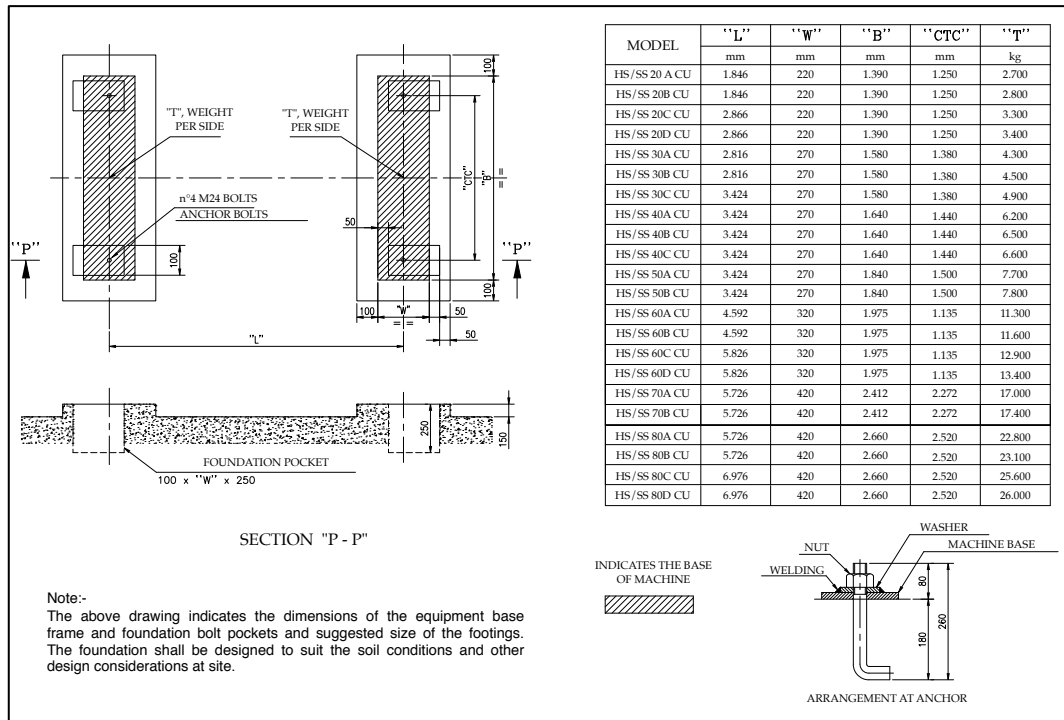

Foundation details for SS/HS series

SS/HS SERIES POSSIBLE APPLICATIONS:

- District heating/cooling
- Cogeneration/Trigeneration
- Food industry
- Automotive industry
- Solar cooling
- Steam from turbines discharge

NECESSARY DATA TO PREPARE AN OFFER

- Cooling capacity required (or alternatively the available heat capacity)
- Chilled water inlet/outlet temperatures
- Cooling water inlet/outlet temperatures
- Superheated water inlet/outlet temperatures (HS)
- Steam pressure (SS)



2G/2B series

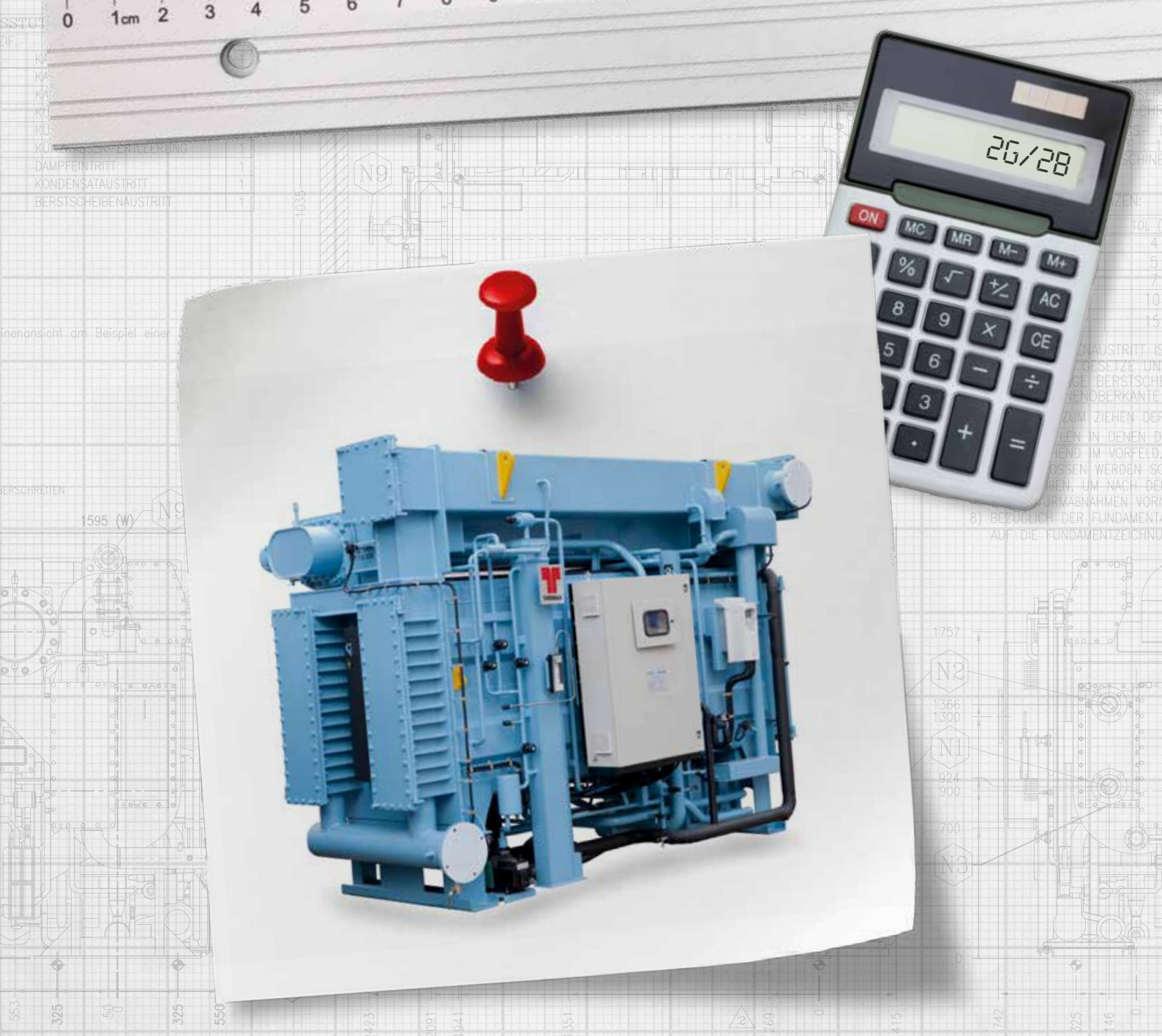
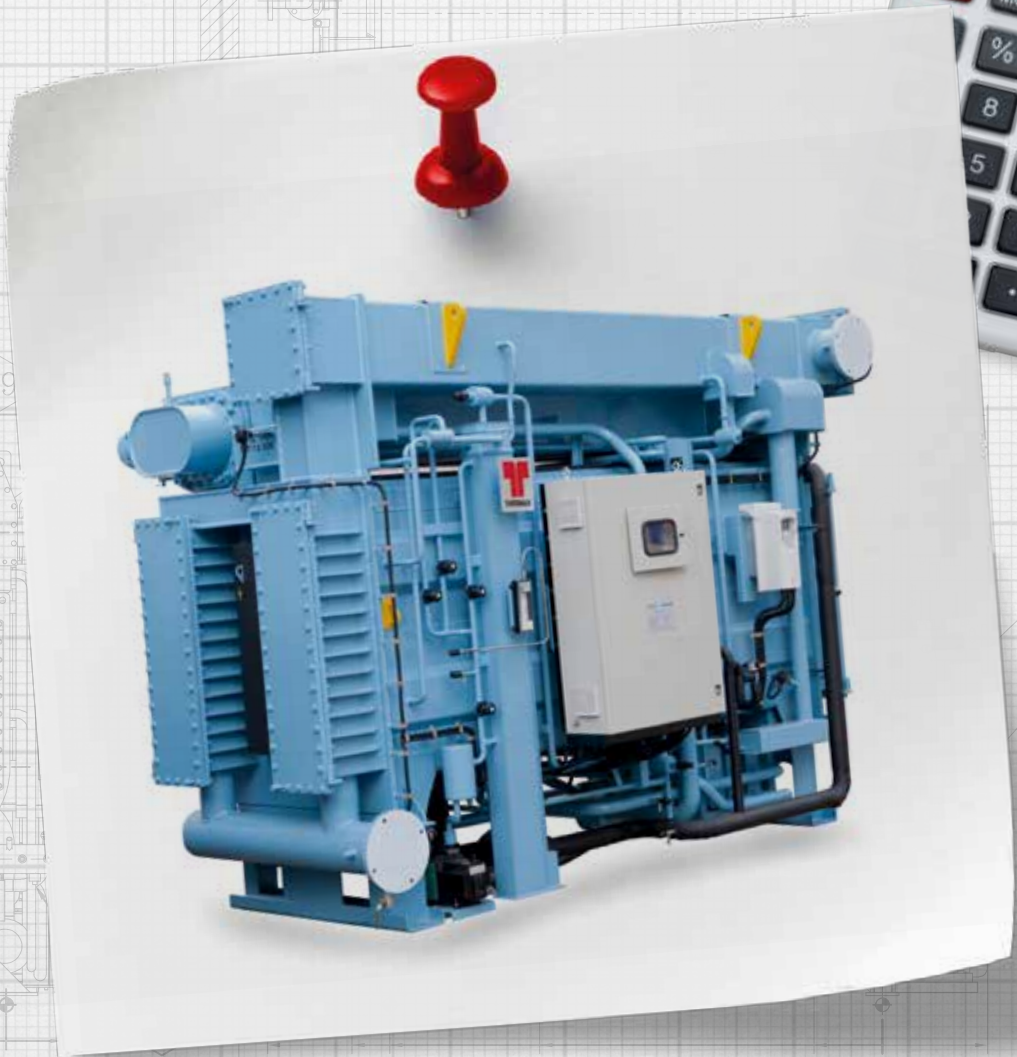
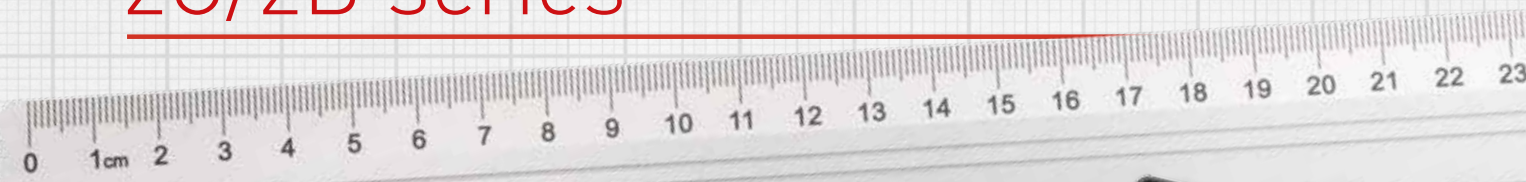
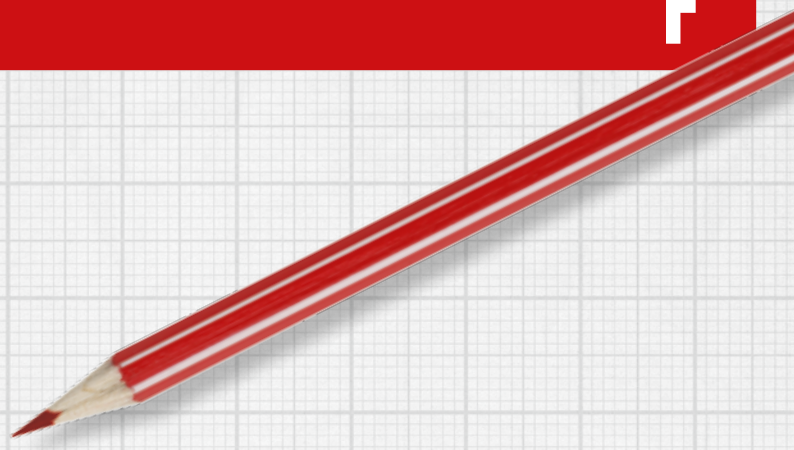

FREIRAUM ZUM ZIEHEN DER ROHRE
(NUR AN EINER DER BEIDEN STIRNSEITEN ERFORDERLICH)



8. 2G/2B SERIES:

Latest generation of double effect high temperature superheated water fired (2G) or steam fired (2B) absorption chillers. This series features a double stage evaporation/absorption technology.

The machines are specifically designed to be used with high temperature superheated water or with steam.

This new generation of machines feature compact dimensions, easy to use, easy to maintenance and one of the highest efficiency of the market.

Cooling capacity from 350 kW to 8.500 kW (higher capacities available upon request).

Superheated water inlet temperature between 155 °C and 180 °C.

Steam pressure between 4 bar (g) and 10 bar (g)

COP: between 1,38 and 1,43

STANDARD FEATURES:

- Triple shell design: the upper shell (including condenser and generator (LTG), the lower shell (including evaporators and the absorbers) and High temperature Generator (HTG)
- The lower shell has a 2 Pressure level design, with 'split' type evaporator and 2 absorbers. This gives the advantage of higher efficiency of absorption (water vapour into sprayed LiBr solution).
- Straight tubes in the generators for easy maintenance.
- Gravity feed spraying technology in evaporator and absorber. Liquids are sprayed downwards on the tubes to ensure good film thickness and better heat transfer.
- Marine type headers in absorber and condenser, for an easy access to the tube bundle without need of lifting systems to support the header. All water boxes have flanged connections. All water boxes are provided with drain and vent connections.
- Crystallization control and prevention based on on-line determination of actual measured concentration.
- Refrigerant autoblowdown solenoid valve controlled by solution concentration
- Level electrodes for refrigerant and solution level monitoring in the evaporator, absorber and HTG.
- PLC based control panel SIEMENS SIMATIC S7-1200
- Alarm state annunciation through an audio signal and appropriate messages display on the operator interface terminal.
- Operator panel SIEMENS TP700, 7" touchscreen.
- MODBUS RTU connectivity as a standard feature.
- Several field interlocks available for plant automation.
- SS 430 Ti tubes in generator.
- DLP copper tubes in evaporator, absorber and condenser.
- Crystallization prevention safeties: overflow pipe for auto decrystallisation, low/high cooling water inlet temperature cut-out, high temperature control for generator, hot water/steam control valve PLC control based on generator temperature.
- PID algorithm capable of achieving part load operation from 10 to 100% stepless, based on chilled water outlet temperature.



- Purge system, which continuously and automatically removes non condensable gases from the shell side and stores them in a tank. A purge pump is provided as standard feature.
- Three (2G) or four (2B) regenerative heat exchangers to increase the efficiency of the cycle. The heat exchangers are plate type, with copper brazed stainless steel plates, designed for the maximum heat exchange with minimum pressure loss. The use of a plate heat exchanger ensures a compact design of the unit.
- Isolating valves for easy removal of the pumps for maintenance without breaking the vacuum inside the chiller.
- Antifreeze protection safeties: PLC inbuilt antifreeze alarm, antifreeze thermostat, low temperature cut-out for refrigerant pump (L-cut), flow switch and D.P. switch for chilled water.
- Completely factory assembled and wired.
- Potential free contacts for remote and automatic operation of the machine: chilled and cooling water pumps start/stop, cooling tower fans start/stop, remote start/stop of the machine, remote indication of machine status (on/off) and machine trip, remote setpoint.
- Rupture disk
- Digital vacuum transmitter
- Inverter on solution pump.
- TRG, a patented bearing monitoring system for monitoring the wear and tear of the bearings (through contacts inside control panel)
- Generator pressure switch

OPTIONAL:

- Stand by refrigerant and solution pumps.
- Special metallurgy for tubes (CuNi 95/5, CuNi 90/10, Stainless steel, Titanium).
- Tubesheet and headers cladding in case of use of bad quality water not suitable for carbon steel
- On line indication of healthiness of bearings of refrigerant and solution pump (on line TRG).
- Insulation of cold and hot surfaces (excluded surfaces at T higher than 150°C).
- Three pieces shipment: unit can be shipped in three pieces to be reassembled on site (lower shell, upper shell and HTG).
- Profibus connection.
- Ethernet or Modbus TCP/IP connection.
- Autopurge system for automatic purging of purge tank (electric or pneumatic).





Double effect steam fired absorption chiller of 2B series

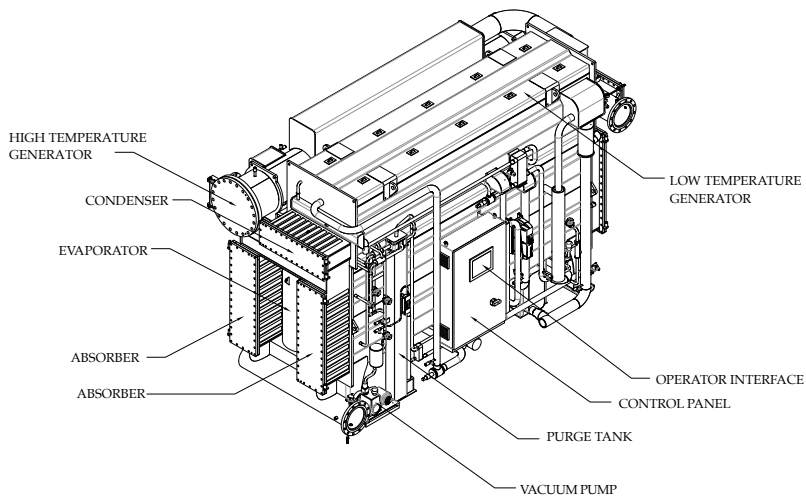

3D view of a 2B machine with main components - Control panel side view

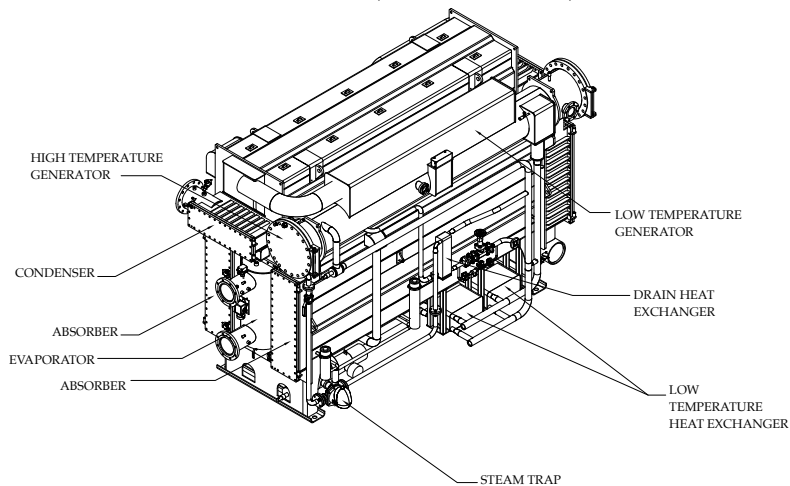

3D view of a 2B machine with main components - Rear view

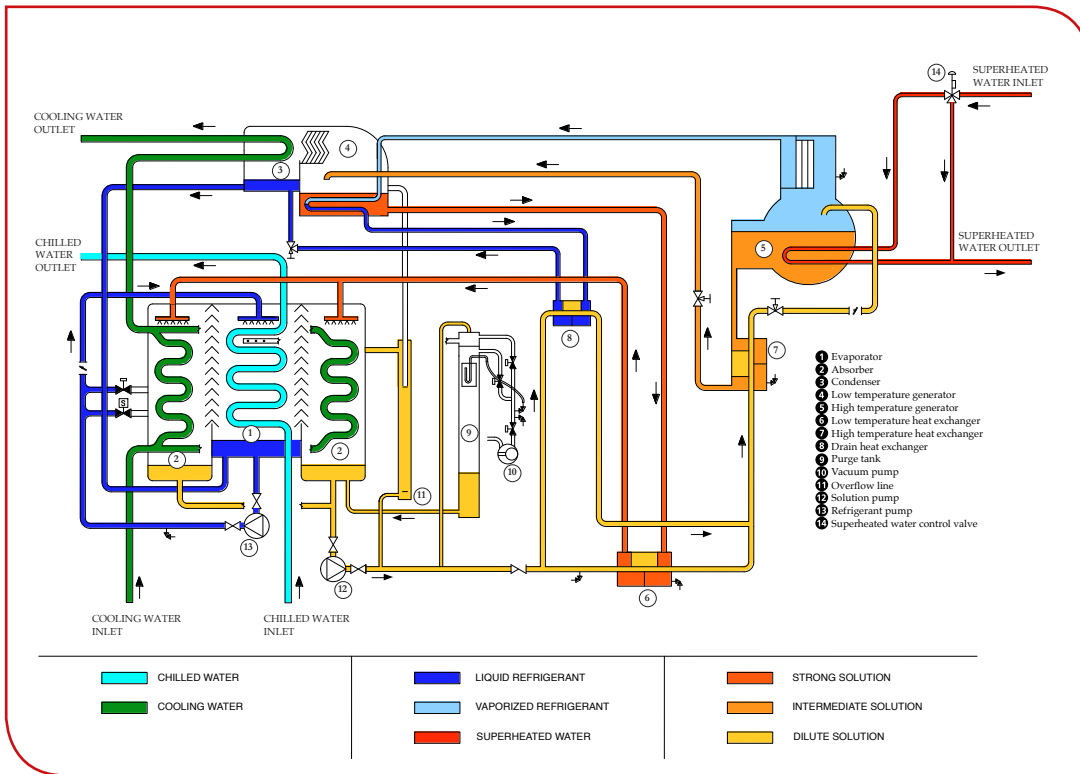

Working cycle of a 2G machine

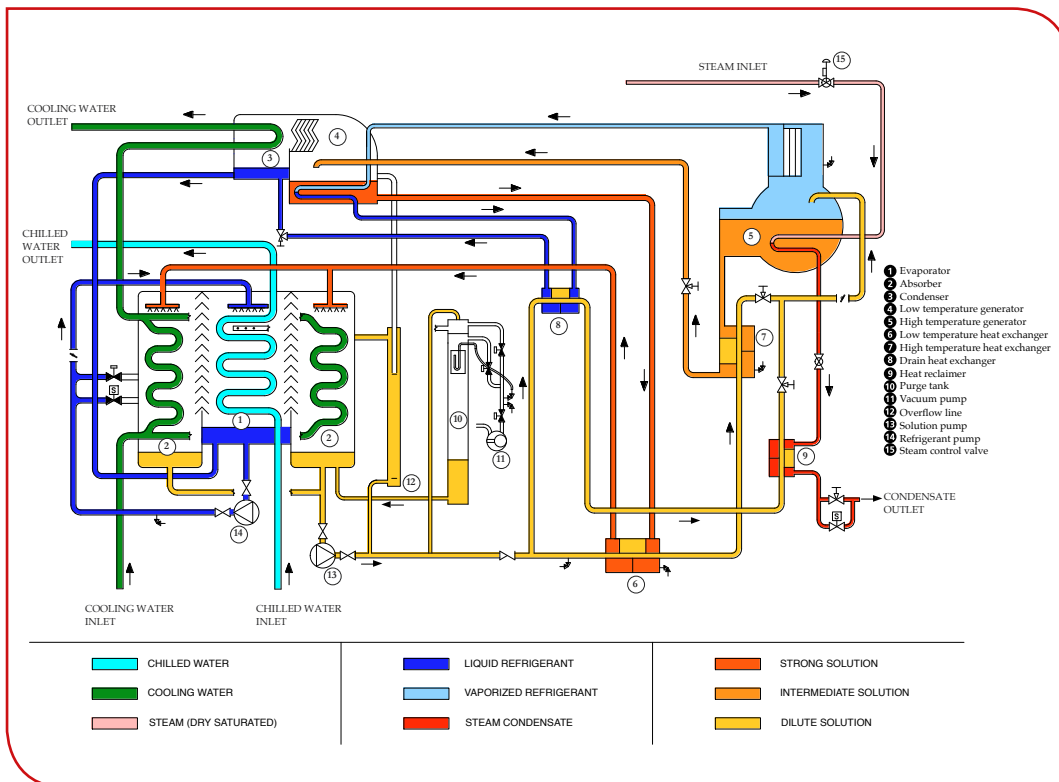

Working cycle of a 2B machine



8. 2G/2B series

		UNITS	2B 2K C	2B 2L C	2B 2M C	2B 2N C	2B 3K C	2B 3L C	2B 3M C	2B 4K C	2B 4L C	2B 4M C	2B 5K C	2B 5L C	2B 5M C	2B 5N C	2B 6K C	2B 6L C	2B 7K C	2B 7L C	2B 7M C	2B 8K C	2B 8L C	2B 8M C	2B 8N C									
Cooling capacity		kW	476	568	704	840	1.005	1.130	1.354	1.515	1.705	1.885	2.086	2.302	2.654	2.965	3.280	3.655	4.665	5.160	5.680	6.580	7.110	7.940	8.490									
Chilled water	Flow	m³/h	81,6	97,4	120,7	144,1	172,4	193,8	232,2	259,9	292,4	323,2	357,8	394,8	455,2	508,6	562,6	626,9	800,1	885	974,2	1.129	1.220	1.362	1.456									
	Connection diameter	DN	125				150				200				250				350				400											
Cooling water	Flow	m³/h	142	170	210	252	300	335	404	450	500	562	622	688	792	882	970	1.094	1.380	1.530	1.641	1.960	2.100	2.337	2.337									
	Connection diameter	DN	150				200				250				300				350				400				450							
Steam	Flow	kg/hr	511,6	610,5	757,7	903,2	1.072	1.205	1.449	1.616	1.819	2.013	2.225	2.455	2.829	3.161	3.535	3.938	5.015	5.545	6.109	7.071	7.641	8.534	9.129									
	Connection diameter (Steam)	DN	65				80				100				100				125				150				200							
	Connection diameter (Condensate)	DN	40				40				40				50				50				65				65							
Dimensions	Length (L)	mm	2850		3870		3990		4590		4720		4810		5870		7340		7480		7580		8830											
	Width (W)	mm	2050		1890		1960		2010		2150		2470		2450		2450		2940		3180		3310											
	Height (H)	mm	2680		2680		2790		2790		3060		3250		3350		3430		3800		4200		4230											
Weights	Working weight	x1000kg	6,8	7,0	8,3	8,6	10,0	10,3	11,5	14,0	14,5	14,9	17,5	18,0	21,7	22,4	27,8	28,7	40,6	41,7	43,1	50,3	51,6	58,5	60,0									
	Shipping weight	x1000kg	6,2	6,3	7,6	7,8	8,9	9,1	10,2	12,2	12,7	12,9	15,1	15,4	18,8	19,3	24,1	24,8	34,6	35,4	36,4	42,3	43,2	49,5	50,7									
Clearance	Clearance for tube removal	mm	2500		3500		3600		4200		4250		4350		5400		6860		6910		6910		8220											
Electrical data	Solution pump	kW(A)	2,2 (6,0)				3,0 (8,0)				3,7 (11,0)				5,5 (14,0)				6,6 (17,0)				7,5 (20,0)				9,0 (27,0)				11,0 (28,0)			
	Refrigerant pump	kW(A)	0,3 (1,4)								1,5 (5,0)																							
	Vacuum pump	kW(A)	0,75 (1,8)																															
	Power consumption	kVA	7,6				9,1				11,2				13,4				15,5				20,3				25,3				26,0			
	Power supply		415 V (±10 %), 50 Hz (±5 %), 3 Phase+N																															

1) Model code: 2B XX - C double effect steam fired absorption chiller, 2) Inlet/Outlet chilled water temperature = 12/7 °C, 3) Inlet/Outlet cooling water temperature = 29/34°C except for models 2B 7M C (29/34,1°C) and 2B 8N C (29/34,4°C) 4) Steam pressure = 8 bar (g), 5.a) Fouling factors: chilled water - 0,018 m²·K/kW, b) Fouling factor cooling water - 0,044m²·K/kW, 6) Minimum chilled water outlet temperature 3,5°C; lower temperatures upon request, 7) Minimum cooling water inlet temperature 10 °C, 8) Plantroom minimum/maximum temperature 5-45 °C, 9) Maximum working pressure in water circuits = 8 bar(g); higher pressures available upon request at extra price, 10) Please contact Thermax representative/office for customised specifications.

		UNITS	2G 2K C	2G 2L C	2G 2M C	2G 2N C	2G 3K C	2G 3L C	2G 3M C	2G 4K C	2G 4L C	2G 4M C	2G 5K C	2G 5L C	2G 5M C	2G 5N C	2G 6K C	2G 6L C	2G 7K C	2G 7L C	2G 7M C	2G 8K C	2G 8L C	2G 8M C	2G 8N C									
Cooling capacity		kW	476	568	704	840	1.005	1.130	1.354	1.515	1.705	1.885	2.086	2.302	2.654	2.965	3.280	3.655	4.665	5.160	5.680	6.580	7.110	7.940	8.490									
Chilled water	Flow	m³/h	81,6	97,4	120,7	144,1	172,4	193,8	232,2	259,9	292,4	323,2	357,8	394,8	455,2	508,6	562,6	626,9	800,1	885	974,2	1.129	1.220	1.362	1.456									
	Connection diameter	DN	125				150				200				200				250				300				350				400			
Cooling water	Flow	m³/h	142	170	210	252	300	335	404	450	500	562	622	688	792	882	970	1.094	1.380	1.530	1.641	1.960	2.100	2.337	2.337									
	Connection diameter	DN	150				200				250				300				350				400				450							
Hot water	Flow	m³/h	20,8	24,7	30,8	36,5	43,7	48,9	59,0	66,0	74,0	81,9	90,6	100,0	115,2	128,6	144,2	160,6	203,1	225,1	247,6	286,6	309,6	345,6	369,6									
	Connection diameter	DN	65		80		80		100		100		125		125		150		150		200		200		250									
Dimensions	Length (L)	mm	2850		3870		3990		4590		4720		4810		5870		7340		7480		7580		8830											
	Width (W)	mm	2050		1890		1960		2010		2150		2375		2470		2450		2940		3180		3310											
	Height (H)	mm	2680		2680		2790		2790		3060		3250		3350		3430		3800		4200		4230											
Weights	Working weight	x1000kg	6,8	7,0	8,3	8,6	10,0	10,3	11,5	14,0	14,5	14,9	17,5	18,0	21,7	22,4	27,8	28,7	40,6	41,7	43,1	50,3	51,6	58,5	60,0									
	Shipping weight	x1000kg	6,2	6,3	7,6	7,8	8,9	9,1	10,2	12,2	12,7	12,9	15,1	15,4	18,8	19,3	24,1	24,8	34,6	35,4	36,4	42,3	43,2	49,5	50,7									
Clearance	Clearance for tube removal	mm	2500		3500		3600		4200		4250		4350		5400		6860		6910		6910		8220											
Electrical data	Solution pump	kW(A)	2,2 (6,0)				3,0 (8,0)				3,7 (11,0)				5,5 (14,0)				6,6 (17,0)				7,5 (20,0)				9,0 (27,0)				11,0 (28,0)			
	Refrigerant pump	kW(A)	0,3 (1,4)								1,5 (5,0)																							
	Vacuum pump	kW(A)	0,75 (1,8)																															
	Power consumption	kVA	7,6				9,1				11,2				13,4				15,5				20,3				25,3				26,0			
	Power supply		415 V (±10 %), 50 Hz (±5 %), 3 Phase+N																															

1) Model code: 2G XX - C double effect superheated water fired absorption chiller, 2) Inlet/Outlet chilled water temperature = 12/7 °C, 3) Inlet/Outlet cooling water temperature = 29/34°C except for models 2G 7M C (29/34,1°C) and 2G 8N C (29/34,4°C) 4) Inlet/Outlet superheated water = 180/165°C, 5.a) Fouling factors: chilled water - 0,018 m²·K/kW, b) Fouling factor cooling water - 0,044m²·K/kW, 6) Minimum chilled water outlet temperature 3,5°C; lower temperatures upon request, 7) Minimum cooling water inlet temperature 10 °C, 8) Plantroom minimum/maximum temperature 5-45 °C, 9) Maximum working pressure in water circuits = 8 bar(g); higher pressures available upon request at extra price, 10) Please contact Thermax representative/office for customised specifications.



NOZZLES ORIENTATION DEPENDING ON NUMBER OF PASSES:

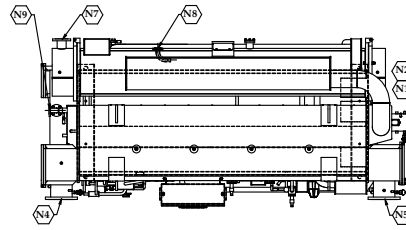
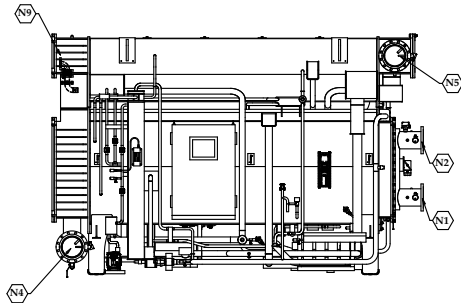

Passes combination: Evaporator (even), Absorber (even), Condenser (1)

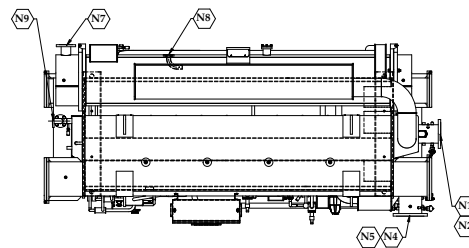
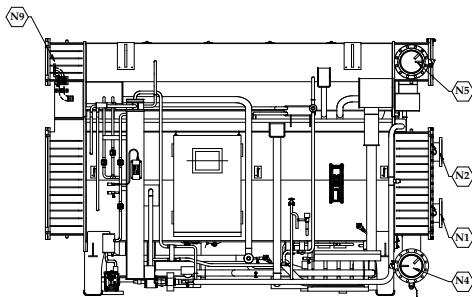

Passes combination: Evaporator (even), Absorber (odd), Condenser (1)

- N1 = Chilled water inlet
- N4 = Cooling water inlet
- N7 = Steam inlet
- N9 = Rupture disk connection

- N2 = Chilled water outlet
- N5 = Cooling water outlet
- N8 = Condensate outlet



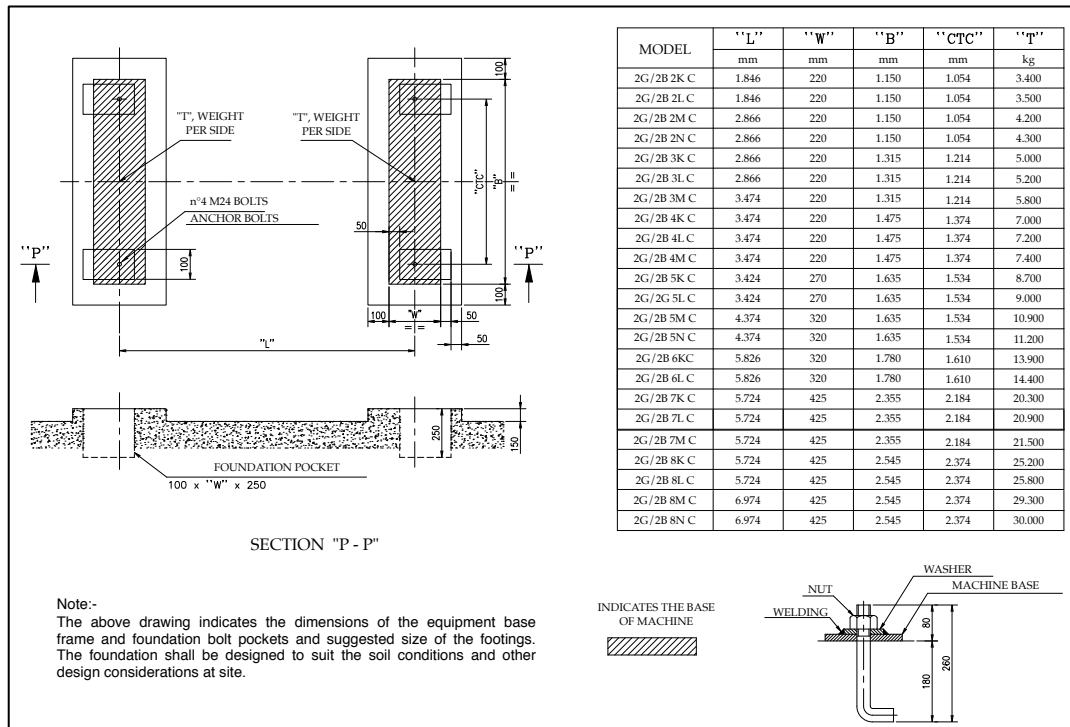

Foundation details for 2G/2B series

SS/HS SERIES POSSIBLE APPLICATIONS:

- District heating/cooling
- Cogeneration/Trigeneration
- Food industry
- Automotive industry
- Solar cooling

NECESSARY DATA TO PREPARE AN OFFER

- Cooling capacity required (or alternatively the available heat capacity)
- Chilled water inlet/outlet temperatures
- Cooling water inlet/outlet temperatures
- Superheated water inlet/outlet temperatures (2G)
- Steam pressure (2B)



2D series



N 80	ASA 150	DAMPFEINTRITT
N 80	ASA 150	KONDENSATAUSTRITT
N 25	ASA 150	BERSTSCHIEBENAUSTRITT
N 100		
N 100		
N 25		
N 40		
N 25		
N 50		

Typische

MASCHINENHÖHE M

2155
N7
1825
1757
N8
1240

2838 (L)
N8

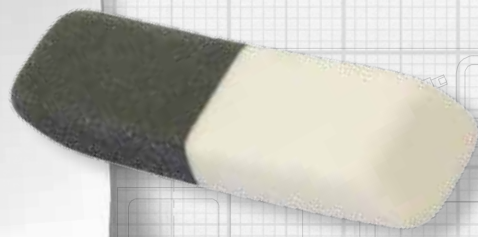
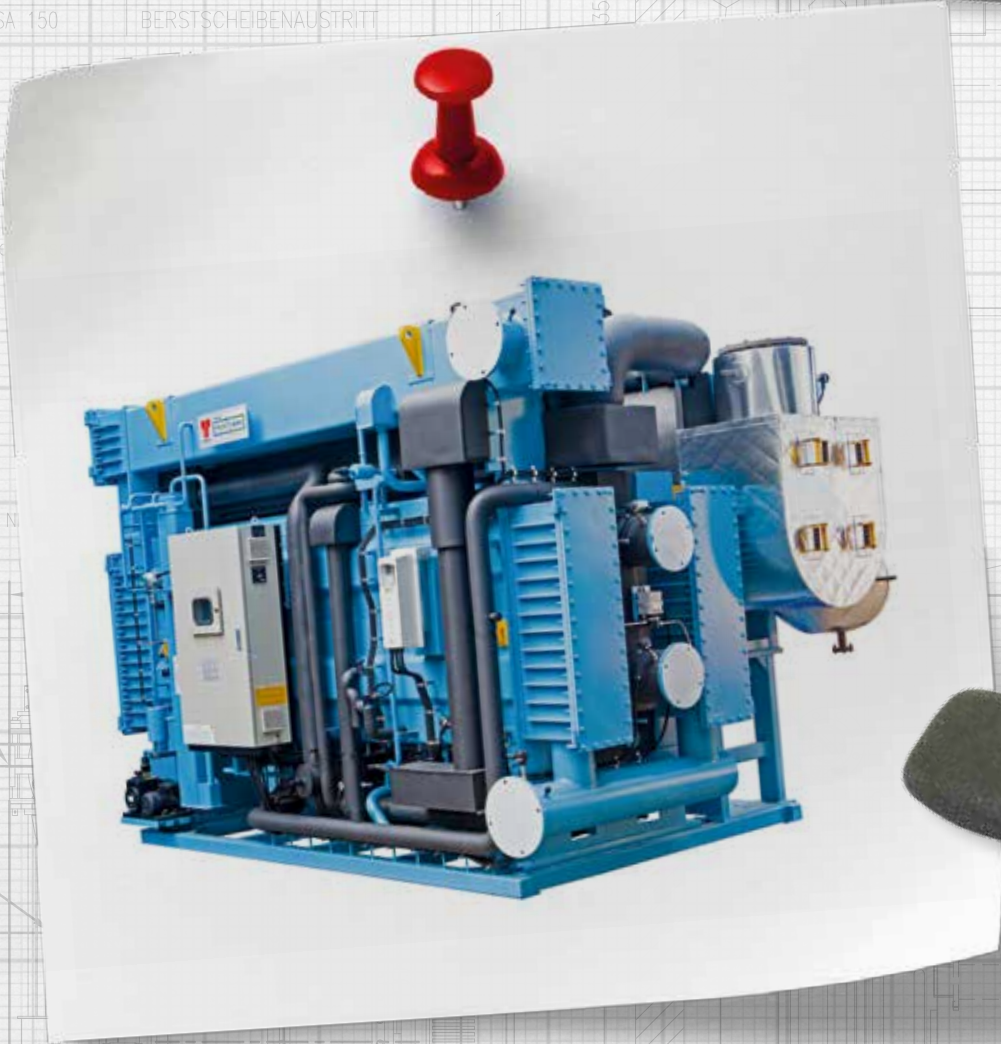

9. 2D SERIES:

Latest generation of double effect exhaust gases fired absorption chillers. This series features a double stage evaporation/absorption technology.

The machines are specifically designed to be used with exhaust gases coming from a gas engine or a gas turbine.

This new generation of machines feature compact dimensions, easy to use, easy to maintenance and one of the highest efficiency of the market.

Cooling capacity from 350 kW to 8.500 kW (higher capacities available upon request).

Exhaust gases temperature between 350 °C and 600 °C (lower temperatures upon request).

COP: between 1,38 and 1,43

STANDARD FEATURES:

- Triple shell design: the upper shell (including condenser and generator (LTG), the lower shell (including evaporators and the absorbers) and High temperature Generator (HTG)
- The lower shell has a 2 Pressure level design, with 'split' type evaporator and 2 absorbers. This gives the advantage of higher efficiency of absorption (water vapour into sprayed LiBr solution).
- Straight tubes in the generators for easy maintenance.
- Gravity feed spraying technology in evaporator and absorber. Liquids are sprayed downwards on the tubes to ensure good film thickness and better heat transfer.
- Marine type headers in absorber and condenser, for an easy access to the tube bundle without need of lifting systems to support the header. All water boxes have flanged connections. All water boxes are provided with drain and vent connections.
- Crystallization control and prevention based on on-line determination of actual measured concentration.
- Refrigerant autoblowdown solenoid valve controlled by solution concentration
- Level electrodes for refrigerant and solution level monitoring in the evaporator, absorber and HTG.
- PLC based control panel SIEMENS SIMATIC S7-1200
- Alarm state annunciation through an audio signal and appropriate messages display on the operator interface terminal.
- Operator panel SIEMENS TP700, 7" touchscreen.
- MODBUS RTU connectivity as a standard feature.
- Several field interlocks available for plant automation.
- Boiler grade carbon steel tubes in high temperature generator.
- DLP copper tubes in evaporator, absorber and condenser.
- Crystallization prevention safeties: overflow pipe for auto decrystallisation, low/high cooling water inlet temperature cut-out, high temperature control for generator, exhaust damper PLC control based on generator temperature.
- PID algorithm capable of achieving part load operation from 10 to 100% stepless, based on chilled water outlet temperature.
- Purge system, which continuously and automatically removes non condensable gases from the shell side and stores them in a tank. A purge pump is provided as standard feature.
- Three regenerative heat exchangers to increase the efficiency of the cycle. The heat exchangers are

plate type, with copper brazed stainless steel plates, designed for the maximum heat exchange with minimum pressure loss. The use of a plate heat exchanger ensures a compact design of the unit.

- Isolating valves for easy removal of the pumps for maintenance without breaking the vacuum inside the chiller.
- Antifreeze protection safeties: PLC inbuilt antifreeze alarm, antifreeze thermostat, low temperature cut-out for refrigerant pump (L-cut), flow switch and D.P. switch for chilled water.
- Completely factory assembled and wired.
- Potential free contacts for remote and automatic operation of the machine: chilled and cooling water pumps start/stop, cooling tower fans start/stop, remote start/stop of the machine, remote indication of machine status (on/off) and machine trip, remote setpoint.
- Rupture disk
- Digital vacuum transmitter
- Inverter on solution pump.
- TRG, a patented bearing monitoring system for monitoring the wear and tear of the bearings (through contacts inside control panel)
- Generator pressure switch.

OPTIONAL:

- Stand by refrigerant and solution pumps.
- Special metallurgy for tubes (CuNi 95/5, CuNi 90/10, Stainless steel, Titanium).
- Tubesheet and headers cladding in case of use of bad quality water not suitable for carbon steel
- On line indication of healthiness of bearings of refrigerant and solution pump (on line TRG).
- Insulation of cold and hot surfaces (excluded surfaces at T higher than 150°C).
- Three pieces shipment: unit can be shipped in three pieces to be reassembled on site (lower shell, upper shell and HTG).
- Profibus connection.
- Ethernet or Modbus TCP/IP connection.
- Autopurge system for automatic purging of purge tank (electric or pneumatic).

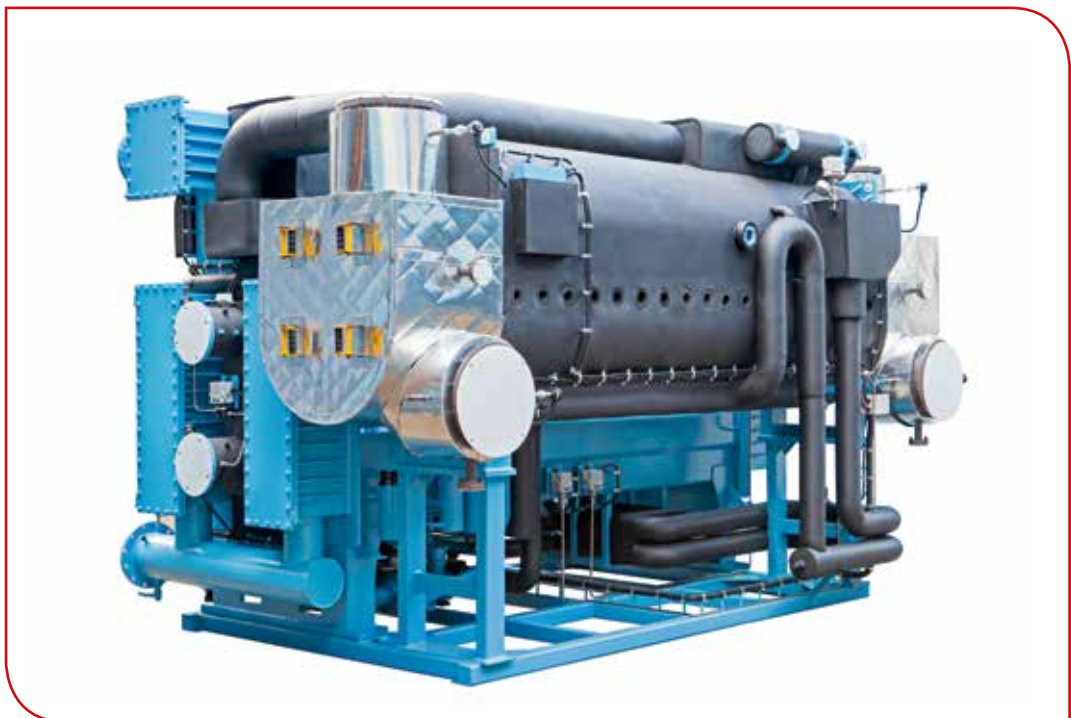
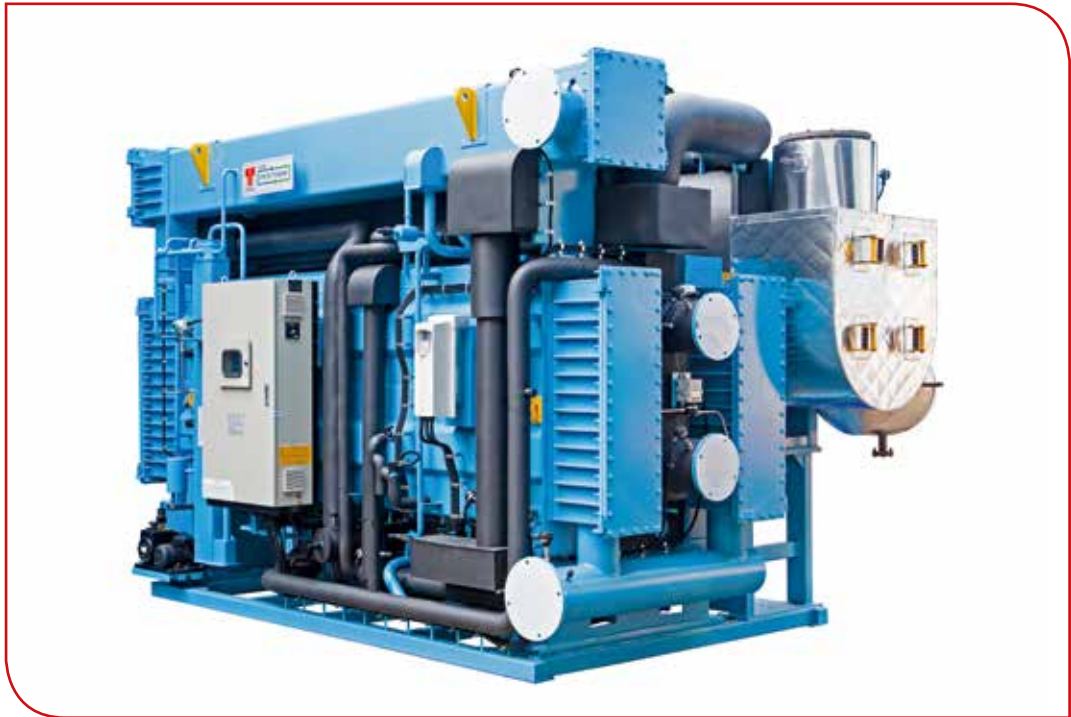

Double effect exhaust fired absorption chiller of 2D series

9. 2D series

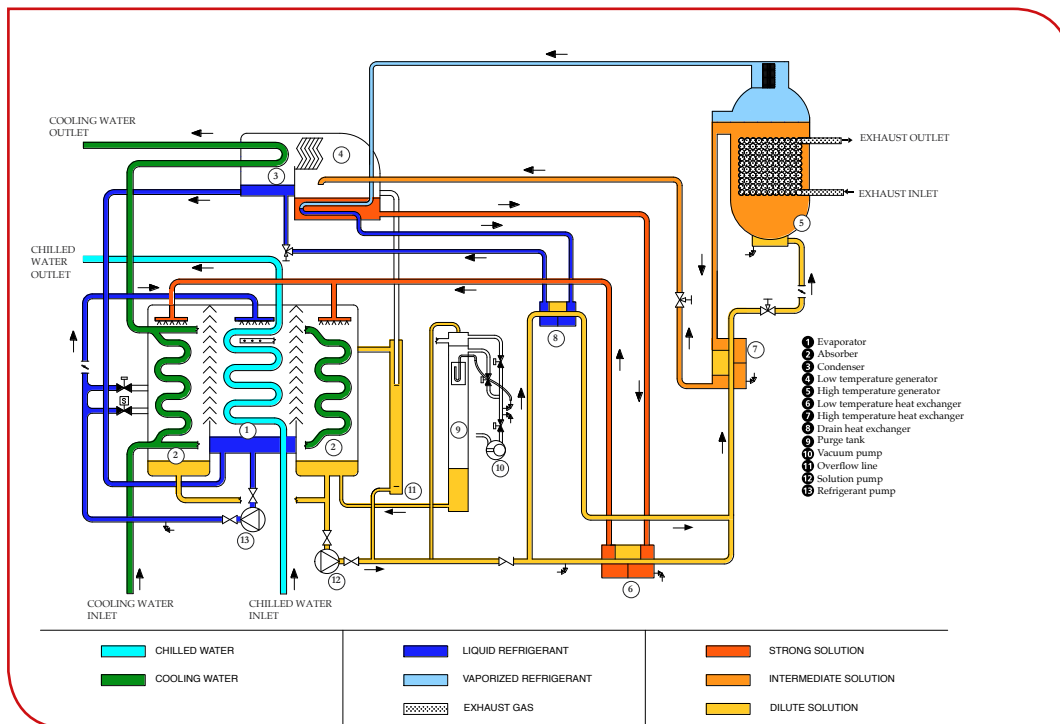

Working cycle of 2D series

		UNITS	2D 2K C	2D 2L C	2D 2M C	2D 2N C	2D 3K C	2D 3L C	2D 3M C	2D 4K C	2D 4L C	2D 4M C	2D 5K C	2D 5L C	2D 5M C	2D 5N C	2D 6K C	2D 6L C	2D 7K C	2D 7L C	2D 7M C	2D 8K C	2D 8L C	2D 8M C	2D 8N C		
Cooling capacity		kW	476	568	704	840	1.005	1.130	1.354	1.515	1.705	1.885	2.086	2.302	2.654	2.965	3.280	3.655	4.665	5.160	5.680	6.580	7.110	7.940	8.490		
	Flow	m ³ /h	81,6	97,4	120,7	144,1	172,4	193,8	232,2	259,9	292,4	323,2	357,8	394,8	455,2	508,6	562,6	626,9	800,1	885	974,2	1.129	1.220	1.362	1.456		
Chilled water	Connection diameter	DN	125		150			200			250			350			400						450				
	Flow	m ³ /h	142	170	210	252	300	335	404	450	500	562	622	688	792	882	970	1.094	1.380	1.530	1.641	1.960	2.100	2.337	2.337		
Cooling water	Connection diameter	DN	150			200			250			300			350			400			450						
	Heat input	kW	338	401	500	592	707	792	955	1.069	1.200	1.327	1.468	1.620	1.865	2.083	2.336	2.602	3.291	3.647	4.012	4.643	5.016	5.598	5.988		
Dimensions	Length (L)	mm	3350		4400		4450		5075		5150		5200		6200		7675		7825		7850		9150				
	Width (W)	mm	2675		2600		2825		2875		3150		3400		3550		3750		4450		4800		5000				
	Height (H)	mm	2790		2790		2890		2890		3160		3350		3450		3530		3900		4350		4380				
Weights	Working weight	x 1000 kg	9,2	9,2	10,9	11,5	13,1	13,5	15,2	18,3	19,0	19,4	22,0	22,7	28,0	28,9	34,6	35,8	48,7	50,1	52,4	59,8	61,6	69,3	71,5		
	Shipping weight	x 1000 kg	8,6	8,8	10,4	10,9	12,3	12,7	14,3	17,3	17,9	18,3	20,6	21,1	26,4	27,1	32,4	33,5	44,8	46,0	48,0	54,4	55,9	63,3	65,3		
Clearance	Clearance for tube removal	mm	2500		3500		3600		4200		4250		4350		5400		6860		6910		6910		8220				
	Solution pump	kW(A)	2,2 (6,0)		3,0 (8,0)			3,7 (11,0)			5,5 (14,0)			6,6 (17,0)			7,5 (20,0)			9,0 (27,0)		11,0 (28,0)					
Electrical data	Refrigerant pump	kW(A)	0,3 (1,4)																								
	Vacuum pump	kW(A)	0,75 (1,8)																								
Power consumption		kVA	7,6		9,1			11,2			13,4			15,5			20,3			25,3		26,0					
	Power supply		415 V (±10 %), 50 Hz (±5 %), 3 Phase+N																								

1) Model code: 2D XX - C double effect exhaust fired absorption chiller, 2) Inlet/Outlet chilled water temperature = 12/7 °C, 3) Inlet/Outlet cooling water temperature = 29/34°C except for models 2D 7M C (29/34,1°C) and 2D 8N C (29/34,4°C) 4) Inlet/Outlet exhaust gases temperature = 450/170°C with specific heat of exhaust of 1,128 kJ/kg °C, 5.a) Fouling factors: chilled water - 0,018 m²-K/kW, b) Fouling factor cooling water - 0,044m²-K/kW, 6) Minimum chilled water outlet temperature 3,5°C; lower temperatures upon request, 7) Minimum cooling water inlet temperature 10 °C, 8) Plantroom minimum/maximum temperature 5-45 °C, 9) Maximum working pressure in water circuits = 8 bar(g); higher pressures available upon request at extra price, 10) Please contact Therman representative/office for customised specifications.



2D SERIES POSSIBLE APPLICATIONS:

- Cogeneration/Trigeneration
- Paper industry
- Automotive industry

NECESSARY DATA TO PREPARE AN OFFER:

- Cooling capacity required (or alternatively the available heat capacity)
- Chilled water inlet/outlet temperatures
- Cooling water inlet/outlet temperatures
- Exhaust flow (in kg/h)
- Exhaust temperature
- Allowable Pressure drop in exhaust furnace

10. 2V series

2V series

ANSCHLUSSSTUTZEN-BELEGUNG			
STUTZEN	GRÖSSE	ANSCHLUSSE	BESCHREIBUNG
N1	DN200	ASA 150	KÜHLWASSEREINTRITT
N2	DN200	ASA 150	KÜHLWASSERAUSTRITT
N3	DN25	NPT(F)	KALTWASSER-VERSORGUNG
N4	DN250	ASA 150	KÜHLWASSEREINTRITT
N5	DN250	ASA 150	KÜHLWASSERAUSTRITT
			WASSER-ENTLEERUNG
			INSTOFFVERSORGUNG EINTRITT
			INSTOFF-AUSTRITT
			DRUCKSCHNEIDENAUSTRITT

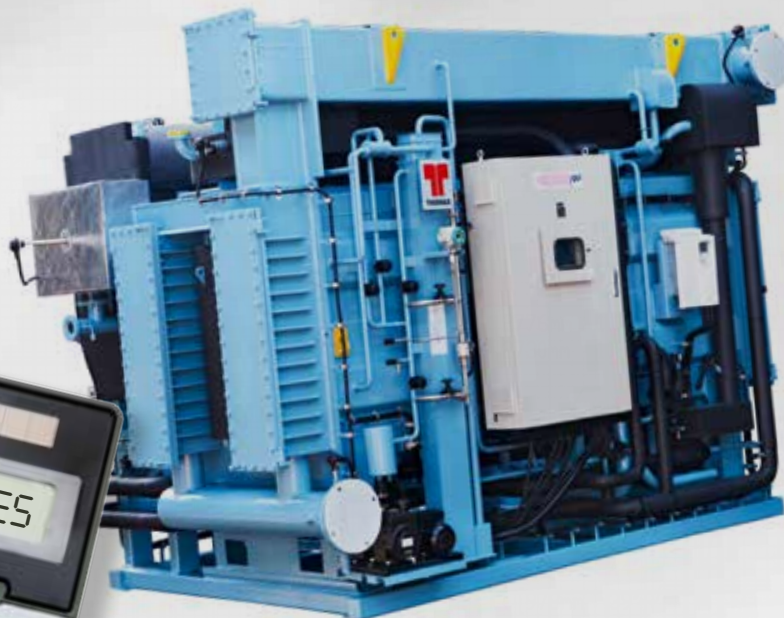

10. 2V SERIES:

Latest generation of double effect direct fired absorption chillers. This series features a double stage evaporation/absorption technology.

The machines are specifically designed to be used with natural gas.

This new generation of machines feature compact dimensions, easy to use, easy to maintenance and one of the highest efficiency of the market.

Cooling capacity from 350 kW to 5.700 kW (higher capacities available upon request).

COP: between 1,38 and 1,43

STANDARD FEATURES:

- Triple shell design: the upper shell (including condenser and generator (LTG), the lower shell (including evaporators and the absorbers) and High temperature Generator (HTG)
- The lower shell has a 2 Pressure level design, with 'split' type evaporator and 2 absorbers. This gives the advantage of higher efficiency of absorption (water vapour into sprayed LiBr solution).
- Straight tubes in the generators for easy maintenance.
- Gravity feed spraying technology in evaporator and absorber. Liquids are sprayed downwards on the tubes to ensure good film thickness and better heat transfer.
- Marine type headers in absorber and condenser, for an easy access to the tube bundle without need of lifting systems to support the header. All water boxes have flanged connections. All water boxes are provided with drain and vent connections.
- Crystallization control and prevention based on on-line determination of actual measured concentration.
- Refrigerant autoblowdown solenoid valve controlled by solution concentration
- Level electrodes for refrigerant and solution level monitoring in the evaporator, absorber and HTG.
- PLC based control panel SIEMENS SIMATIC S7-1200
- Alarm state annunciation through an audio signal and appropriate messages display on the operator interface terminal.
- Operator panel SIEMENS TP700, 7" touchscreen.
- MODBUS RTU connectivity as a standard feature.
- Several field interlocks available for plant automation.
- Boiler grade carbon steel tubes in high temperature generator.
- DLP copper tubes in evaporator, absorber and condenser.
- Crystallization prevention safeties: overflow pipe for auto decrystallisation, low/high cooling water inlet temperature cut-out, high temperature control for generator, gas burner PLC control based on generator temperature.
- PID algorithm capable of achieving part load operation from 10 to 100% stepless, based on chilled water outlet temperature.
- Purge system, which continuously and automatically removes non condensable gases from the shell side and stores them in a tank. A purge pump is provided as standard feature.



- Three regenerative heat exchangers to increase the efficiency of the cycle. The heat exchangers are plate type, with copper brazed stainless steel plates, designed for the maximum heat exchange with minimum pressure loss. The use of a plate heat exchanger ensures a compact design of the unit.
- Isolating valves for easy removal of the pumps for maintenance without breaking the vacuum inside the chiller.
- Antifreeze protection safeties: PLC inbuilt antifreeze alarm, antifreeze thermostat, low temperature cut-out for refrigerant pump (L-cut), flow switch and D.P. switch for chilled water.
- Completely factory assembled and wired.
- Potential free contacts for remote and automatic operation of the machine: chilled and cooling water pumps start/stop, cooling tower fans start/stop, remote start/stop of the machine, remote indication of machine status (on/off) and machine trip, remote setpoint.
- Rupture disk
- Digital vacuum transmitter
- Inverter on solution pump.
- TRG, a patented bearing monitoring system for monitoring the wear and tear of the bearings (through contacts inside control panel)
- Generator pressure switch.
- Hi-low or modulating burner, depending on models.

OPTIONAL:

- Stand by refrigerant and solution pumps.
- Special metallurgy for tubes (CuNi 95/5, CuNi 90/10, Stainless steel, Titanium).
- Tubesheet and headers cladding in case of use of bad quality water not suitable for carbon steel
- On line indication of healthiness of bearings of refrigerant and solution pump (on line TRG).
- Insulation of cold and hot surfaces (excluded surfaces at T higher than 150°C).
- Three pieces shipment: unit can be shipped in three pieces to be reassembled on site (lower shell, upper shell and HTG).
- Profibus connection.
- Ethernet or Modbus TCP/IP connection.
- Autopurge system for automatic purging of purge tank (electric or pneumatic).
- Special version with reverse cycle valve to generate hot water up to 60°C
- Special version with additional heat exchanger to generate hot water up to 90°C
- Special version with additional heat exchanger to generate simultaneously chilled water and hot water.





Double effect direct fired absorption chiller of 2V series

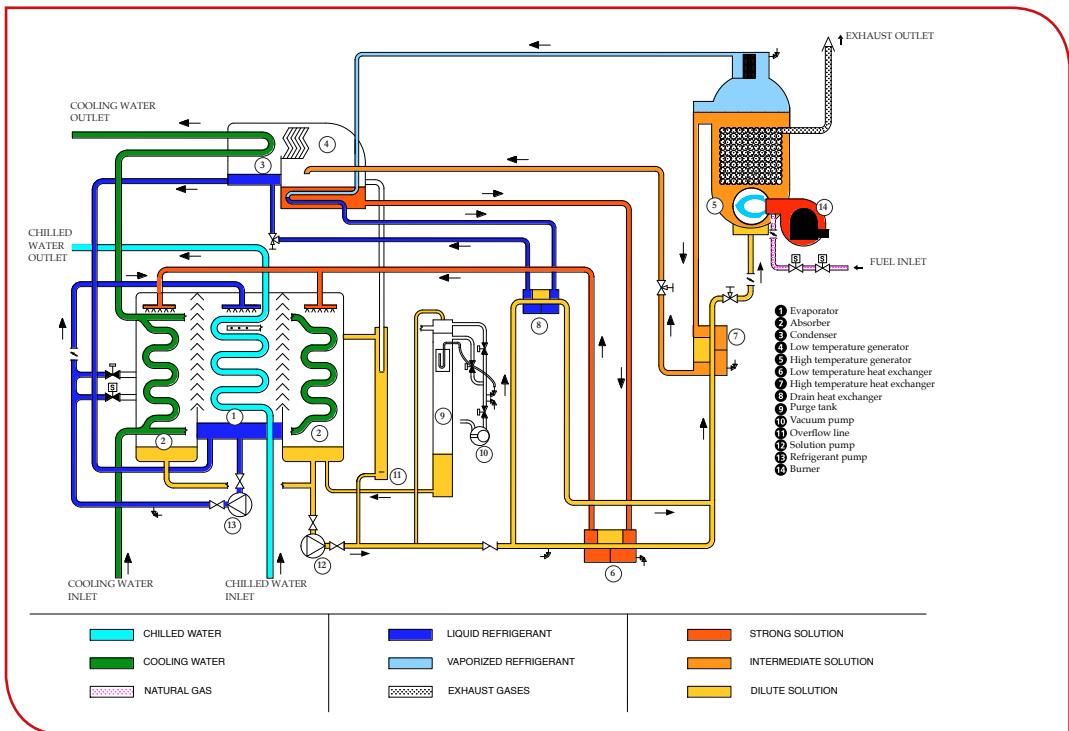

Working cycle of 2V series

10. 2V series



	UNITS	2V 2K C	2V 2L C	2V 2M C	2V 2N C	2V 3K C	2V 3L C	2V 3M C	2V 4K C	2V 4L C	2V 4M C	2V 5K C	2V 5L C	2V 5M C	2V 5N C	2V 6K C	2V 6L C	2V 7K C	2V 7L C	2V 7M C											
Cooling capacity	kW	476	568	704	840	1.005	1.130	1.354	1.515	1.705	1.885	2.086	2.302	2.654	2.965	3.280	3.655	4.665	5.160	5.452											
Chilled water	Flow	m ³ /h	81,6	97,4	120,7	144,1	172,4	193,8	232,2	259,9	292,4	323,2	357,8	394,8	455,2	508,6	562,6	626,9	800,1	885	935,1										
	Connection diameter	DN	125			150			200			200			250			350													
Cooling water	Flow	m ³ /h	142	170	210	252	300	335	404	450	500	562	622	688	792	882	970	1.094	1.380	1.530	1.620										
	Connection diameter	DN	150			200			250			300			350			400													
Gas circuit	Gas consumption	m ³ /h	34,8	41,3	51,5	61	72,9	81,7	98,5	110,2	123,7	136,9	151,4	167	192,4	214,7	240,8	268,3	339,3	376	396,7										
	Stack connection diameter	DN	150		200		250		300		350		150		500		550														
Dimensions	Length (L)	mm	3270		4285		4325		4930		4975		5010		6010		7465		7595												
	Width (W)	mm	2640		2550		2550		2800		3070		3300		3450		3640		4310												
	Height (H)	mm	2790		2790		2890		2890		3160		3350		3450		3530		3900												
Weights	Working weight	x 1000 kg	9,0	9,2	10,9	11,5	13,1	13,5	15,2	18,3	19,0	19,4	22,0	22,7	28,0	28,9	34,6	35,8	48,7	50,1	52,4										
	Shipping weight	x 1000 kg	8,4	8,5	10,1	10,6	11,9	12,3	13,9	16,5	17,1	17,4	19,6	20,1	25,1	25,8	30,9	31,9	42,7	43,8	45,7										
Clearance	Clearance for tube removal	mm	2500		3500		3600		4200		4250		4350		5400		6860		6910												
Electrical data	Solution pump	kW(A)	2,2 (6,0)			3,0 (8,0)			3,7 (11,0)			5,5 (14,0)			6,6 (17,0)			7,5 (20,0)													
	Refrigerant pump	kW(A)	0,3 (1,4)						1,5 (5,0)																						
	Vacuum pump	kW(A)	0,75 (1,8)																												
	Power consumption	kVA	11,2			13,4			14,8			15,3			17,5			23,9			26,1			26,4			36,7			41,6	
Power supply			415 V (±10 %), 50 Hz (±5 %), 3 Phase+N																												

1) Model code: 2V XX - C double effect direct fired absorption chiller, 2) Inlet/Outlet chilled water temperature = 12/7 °C, 3) Inlet/Outlet cooling water temperature = 29/34°C 4) Net calorific value of gas = 37.681 kJ/Nm³, 5.a) Fouling factors: chilled water - 0,018 m²-K/kW, b) Fouling factor cooling water - 0,044m²-K/kW, 6) Minimum chilled water outlet temperature 3,5°C; lower temperatures upon request, 7) Minimum cooling water inlet temperature 10 °C, 8) Plantroom minimum/maximum temperature 5-45 °C, 9) Maximum working pressure in water circuits = 8 bar(g); higher pressures available upon request at extra price, 10) Please contact Thermax representative/office for customised specifications.

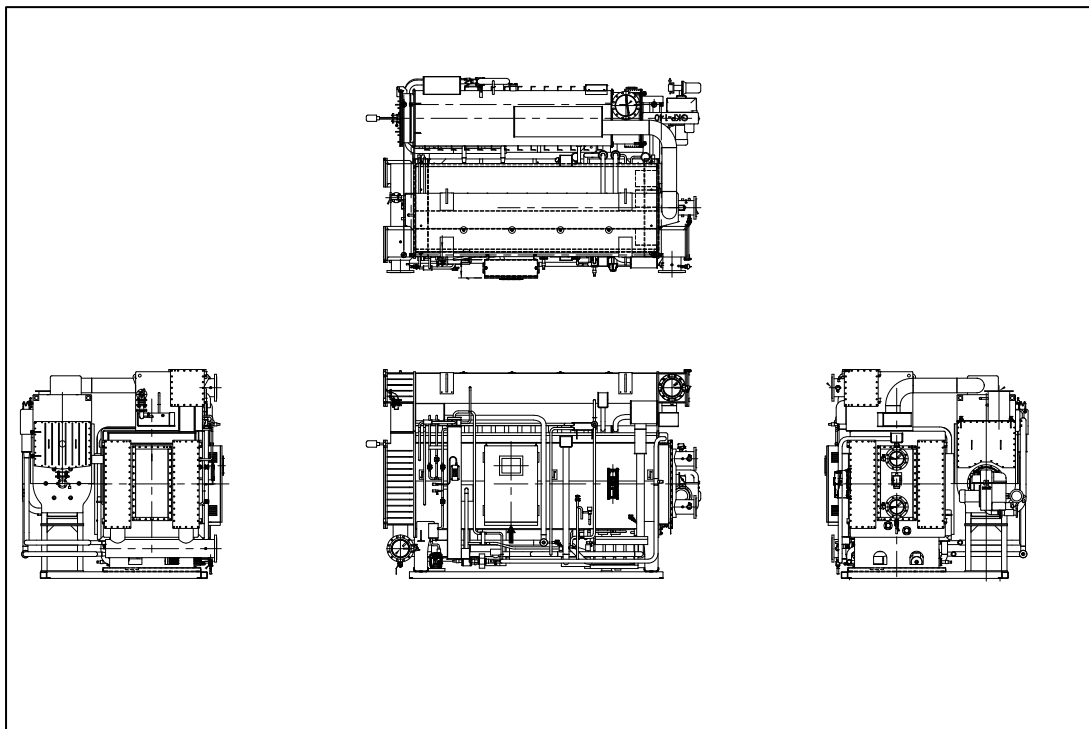

Typical layout of 2V series



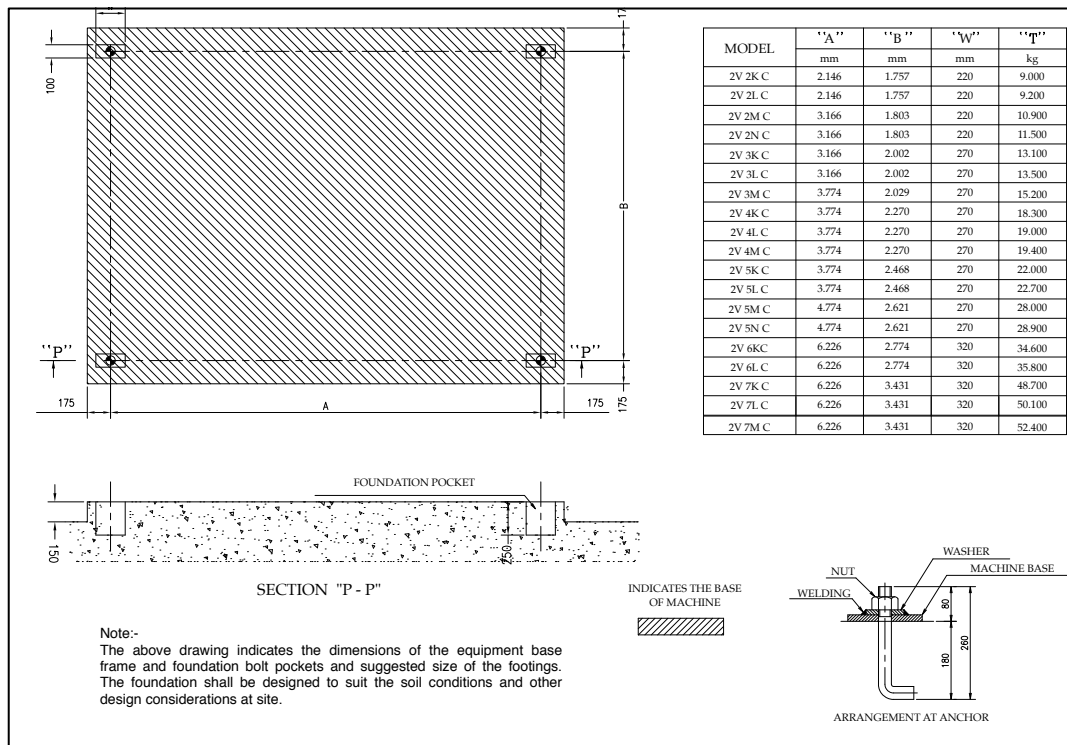

Foundation details of 2V series

2V SERIES POSSIBLE APPLICATIONS:

- Installations with fiscal facilities on gas price
- Installations with low electrical power available
- Installations requiring cooling and heating generation

NECESSARY DATA TO PREPARE AN OFFER:

- Cooling capacity required (or alternatively the available heat capacity)
- Chilled water inlet/outlet temperatures
- Cooling water inlet/outlet temperatures
- Calorific value of gas



EJ SERIES

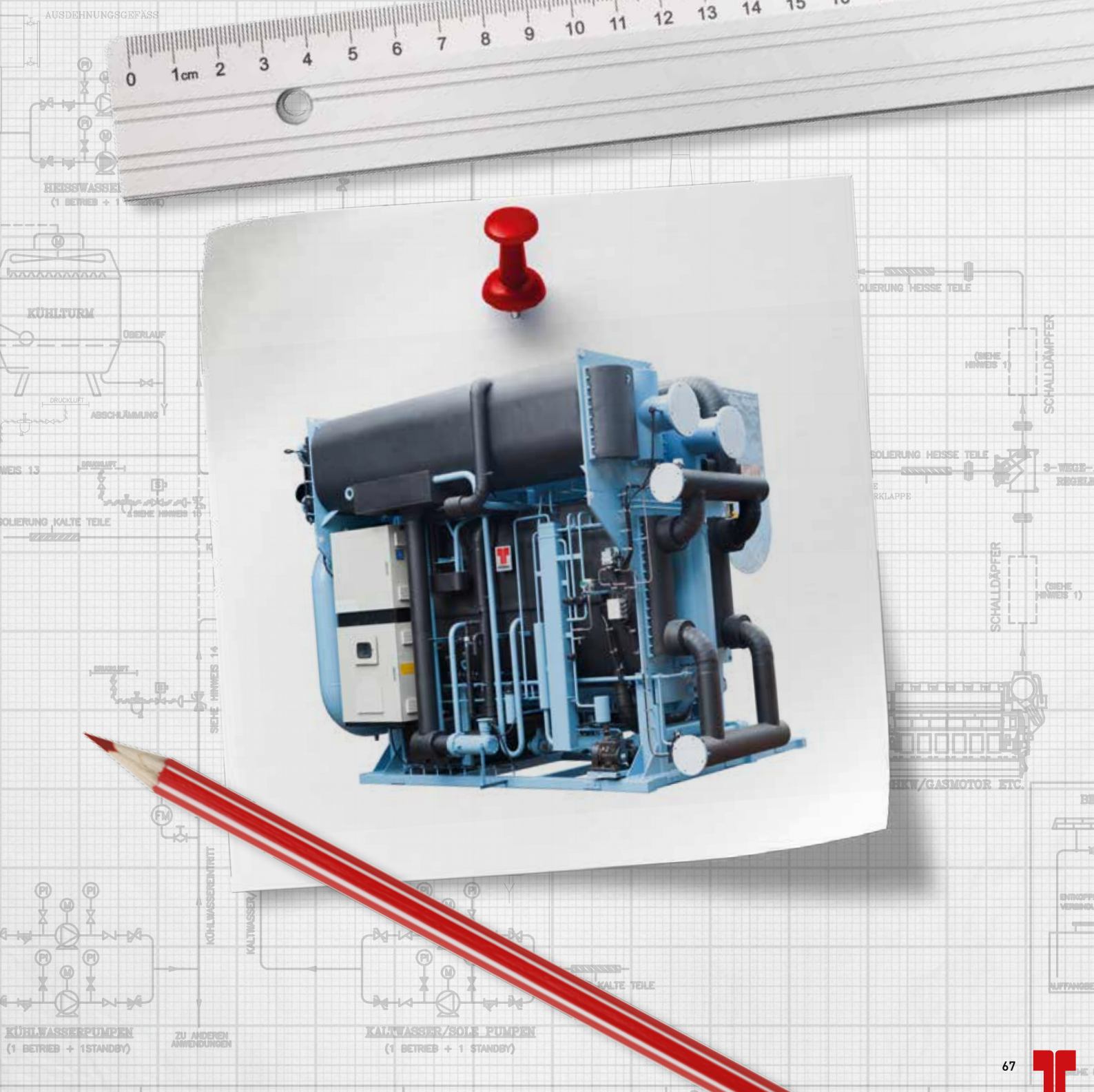
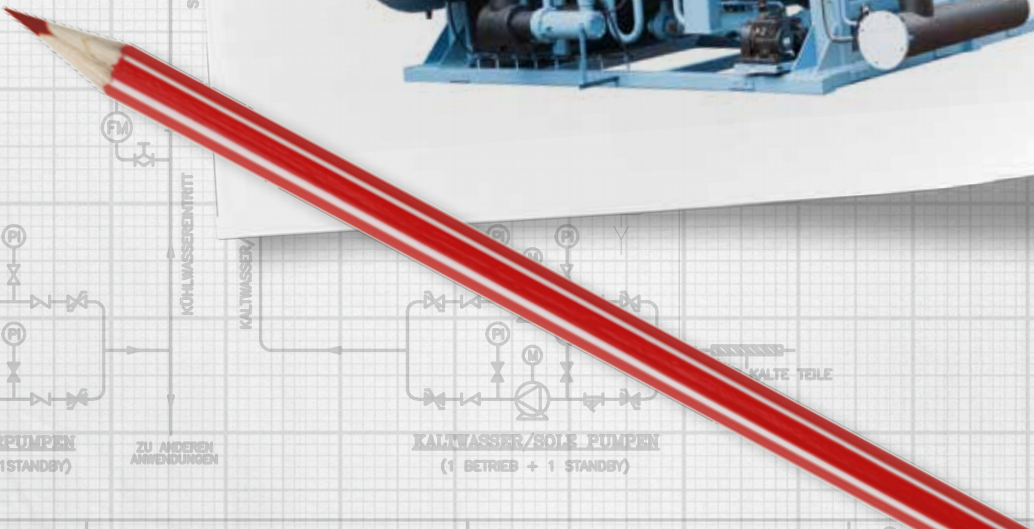
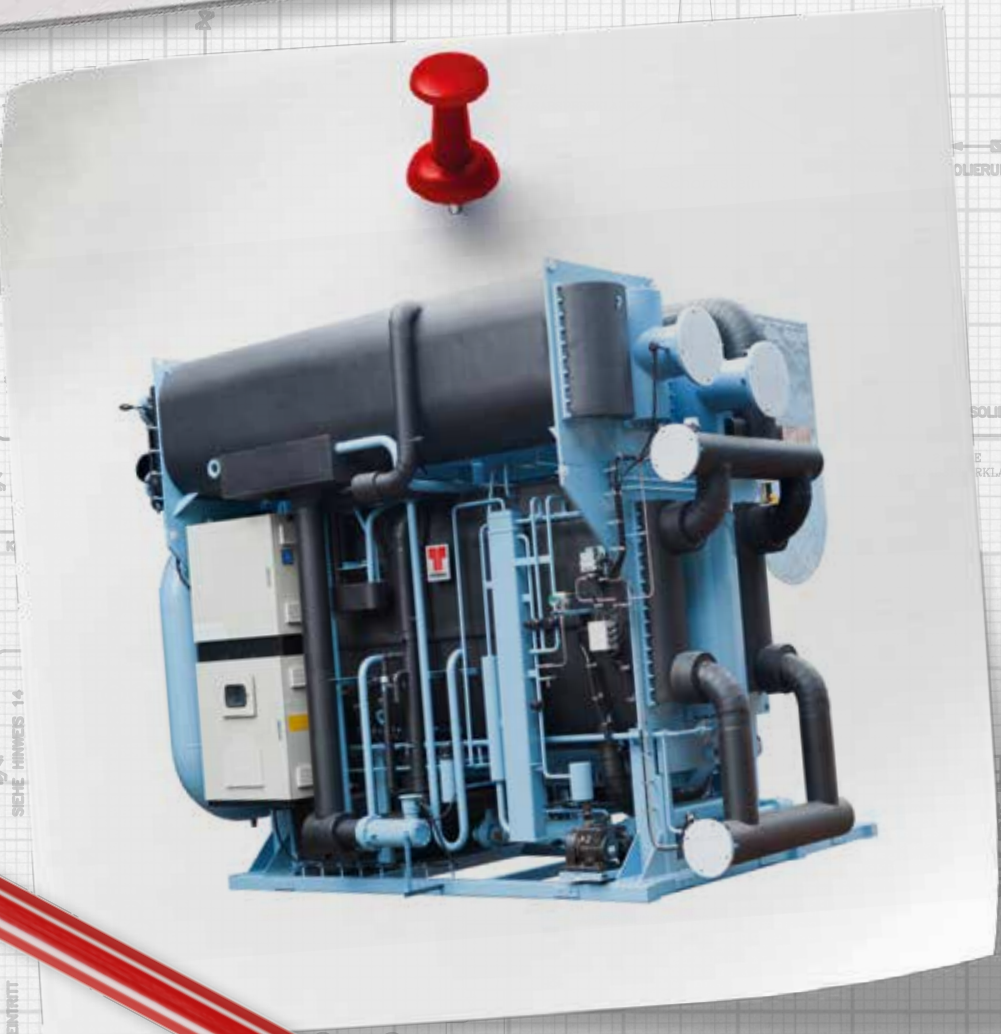
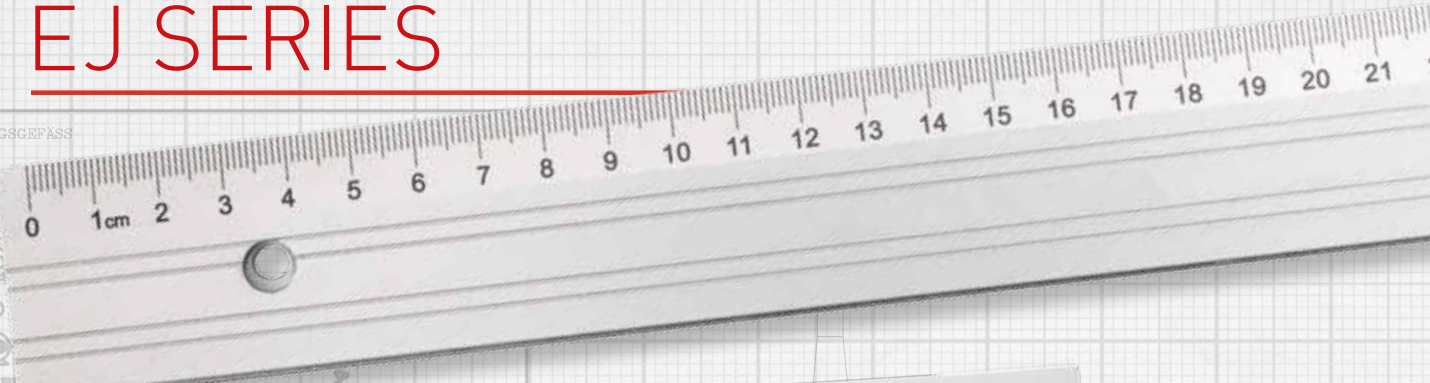

11. EJ SERIES:

„J“ series machines can be fired with multiple heat sources simultaneously. The most common model of the series is the „EJ“ series, that can be fired with hot water and exhaust gases at the same time. Other options are anyway available, like the steam + hot water one (SJ) or the superheated water + hot water one (HJ).

All the machines of the series feature three different generators: one fired by the low temperature heat source (hot water) and two fired with the high temperature heat source. Basically it is just like if the machine is running a single effect cycle and a double effect cycle at the same time.

With the “J” series it is possible to maximize the cooling output of the machine at same heat input, with much more compact dimensions respect to the use of two separate machines.

Cooling capacity 455 kW-7 MW.

HIGH TEMPERATURE HEAT SOURCE

Exhaust gases: 350 °C-600 °C

Steam: 4 bar(g)-10 bar(g)

Superheated water: 155 °C-180 °C

LOW TEMPERATURE HEAT SOURCE

Hot water: 85 °C-120 °C

BACK UP BURNER AVAILABLE IN OPTION

COP: between 0,95 and 1,1

STANDARD FEATURES:

- Triple shell design: the upper shell (including the two condensers, the low temperature generator (LTG) and the hot water fired generator, the lower shell (including evaporators and the absorbers) and High temperature Generator (HTG).
- “Split” type evaporator: the evaporator is divided into two different tube bundles, placed on both sides of the absorber, that remains in the middle of the two evaporators. This solution grants a better efficiency at part load, optimizing the mass transfer inside the solution.
- Straight tubes in the generators for easy maintenance.
- Gravity feed spraying technology in evaporator and absorber. Liquids are sprayed downwards on the tubes to ensure good film thickness and better heat transfer.
- Marine type headers in absorber and condenser, for an easy access to the tube bundle without need of lifting systems to support the header. All water boxes have flanged connections. All water boxes are provided with drain and vent connections.
- Crystallization control and prevention based on on-line determination of actual measured concentration.
- Refrigerant autoblowdown solenoid valve controlled by solution concentration
- Level electrodes for refrigerant and solution level monitoring in the evaporator, absorber and HTG.
- PLC based control panel SIEMENS SIMATIC S7-1200
- Alarm state annunciation through an audio signal and appropriate messages display on the opera-

tor interface terminal.

- Operator panel SIEMENS TP700, 7" touchscreen.
- MODBUS RTU connectivity as a standard feature.
- Several field interlocks available for plant automation.
- Boiler grade carbon steel tubes in high temperature generator (in case of exhasut fired firing). SS 430 Ti tubes in case of steam firing.
- DLP copper tubes in evaporator, absorber and condenser.
- Crystallization prevention safeties: overflow pipe for auto decrystallisation, low/high cooling water inlet temperature cut-out, high temperature control for generator, heat input PLC control based on generator temperature.
- PID algorithm capable of achieving part load operation from 10 to 100% stepless, based on chilled water outlet temperature.
- Purge system, which continuously and automatically removes non condensable gases from the shell side and stores them in a tank. A purge pump is provided as standard feature.
- Three regenerative heat exchangers to increase the efficiency of the cycle. The heat exchangers are plate type, with copper brazed stainless steel plates, designed for the maximum heat exchange with minimum pressure loss. The use of a plate heat exchanger ensures a compact design of the unit.
- Isolating valves for easy removal of the pumps for maintenance without breaking the vacuum inside the chiller.
- Antifreeze protection safeties: PLC inbuilt antifreeze alarm, antifreeze thermostat, low temperature cut-out for refrigerant pump (L-cut), flow switch and D.P. switch for chilled water.
- Completely factory assembled and wired.
- Potential free contacts for remote and automatic operation of the machine: chilled and cooling water pumps start/stop, cooling tower fans start/stop, remote start/stop of the machine, remote indication of machine status (on/off) and machine trip, remote setpoint.
- Rupture disk
- Digital vacuum transmitter
- Inverter on solution pumps.
- TRG, a patented bearing monitoring system for monitoring the wear and tear of the bearings (through contacts inside control panel)
- Generator pressure switch.

OPTIONAL:

- Stand by refrigerant and solution pumps.
- Special metallurgy for tubes (CuNi 95/5, CuNi 90/10, Stainless steel, Titanium).
- Tubesheet and headers cladding in case of use of bad quality water not suitable for carbon steel
- On line indication of healthiness of bearings of refrigerant and solution pump (on line TRG).
- Insulation of cold and hot surfaces (excluded surfaces at T higher than 150°C).
- Multiple pieces shipment: unit can be shipped in multiple pieces to be reassembled on site.
- Profibus connection.
- Ethernet or Modbus TCP/IP connection.
- Autopurge system for automatic purging of purge tank (electric or pneumatic).
- Back up burner

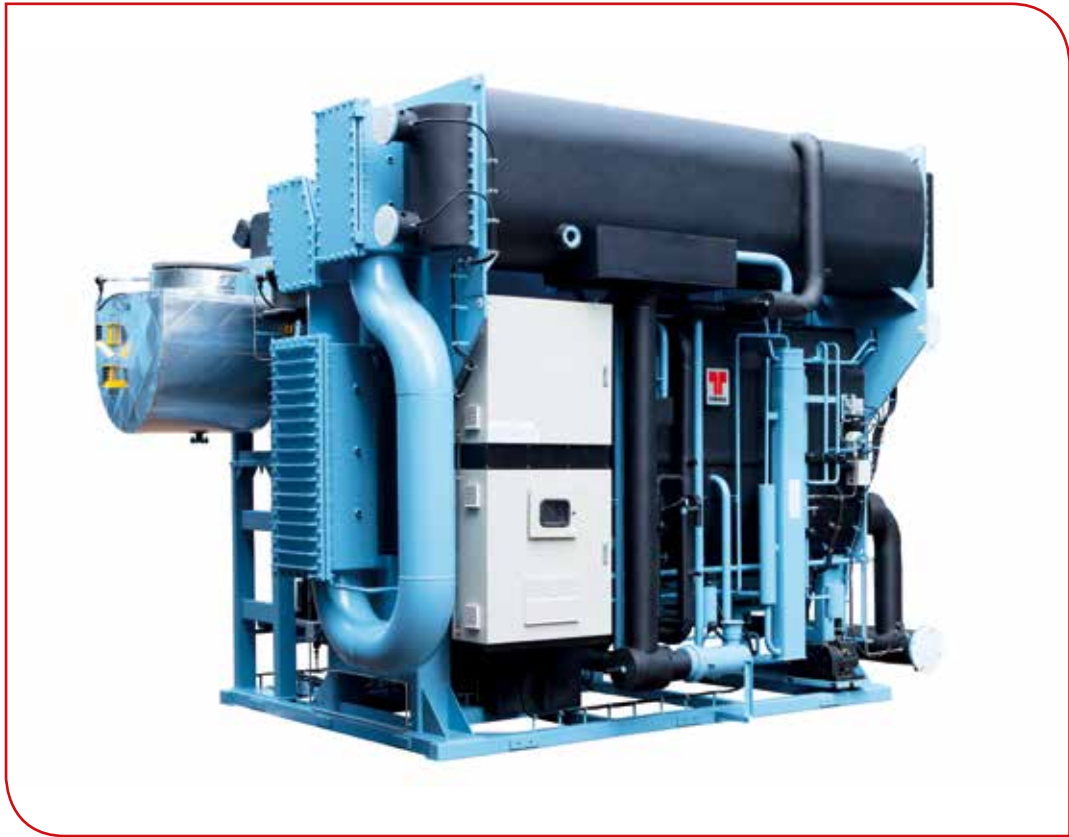

EJ series absorption chiller fired with exhaust gases + hot water

11. EJ series

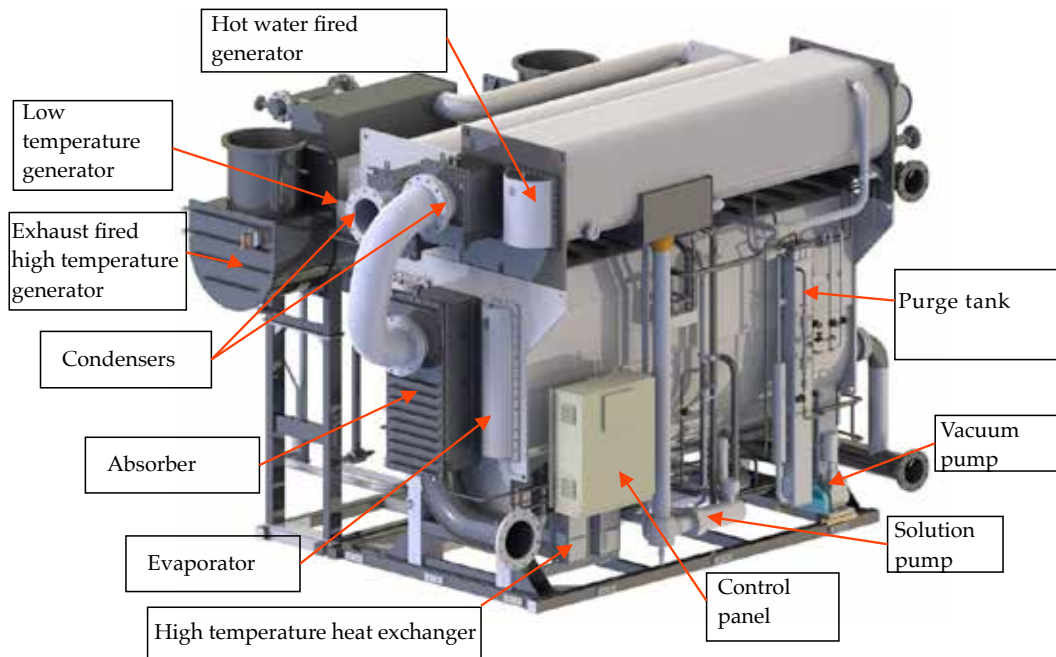

3D view of an EJ machine

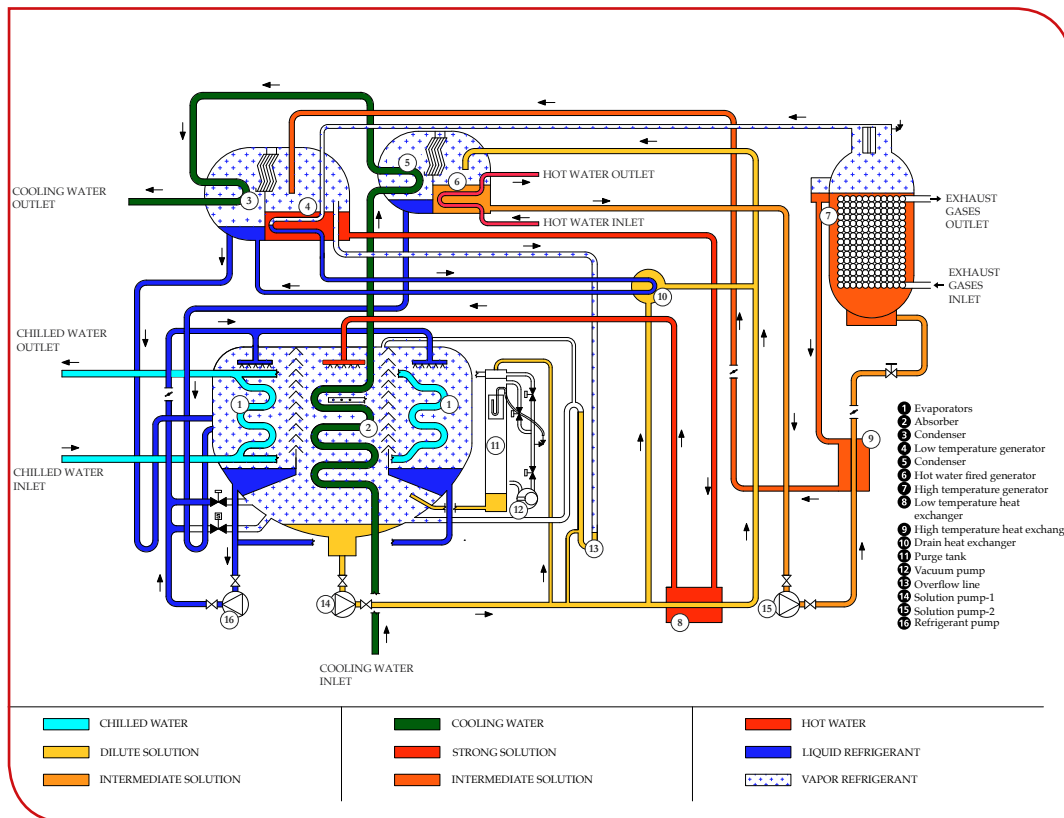

Working cycle of EJ series



EJ SERIES POSSIBLE APPLICATIONS:

- Cogeneration/Trigeneration when it is important to maximize the cooling capacity with the smallest footprint: industries, hospitals, airports, etc

NECESSARY DATA TO PREPARE AN OFFER:

- Cooling capacity required (or alternatively the available heat capacity)
- Chilled water inlet/outlet temperatures
- Cooling water inlet/outlet temperatures
- Hot water inlet/outlet temperatures
- Exhaust gases temperature
- Exhaust gases flow (in kg/h)
- Allowable Pressure drop in exhaust furnace

12. HIGH EFFICIENCY CHILLER/HEATER (HEATING AND COOLING SIMULTANEOUSLY)

High efficiency Chiller/Heater is an absorption chiller capable to provide cooling and heating simultaneously in a very efficient way.

Traditionally hot water generators have been used to generate hot water, which are either fossil fuel fired (like gas, oil, etc) or Steam fired. Steam being generated again using fossil fuel fired boiler. Thus for producing ~90°C hot water, flue gases at 1000°C produced by combustion of fuels are used, i.e. high grade heat is used to produce low temperature hot water. These systems require close to 115 kW of fuel energy input for producing hot water of 100 kW heat content. 15 kW of heat is lost due to energy losses in combustion.

Additionally there could be applications in industry where both chilled water and hot water are required simultaneously. With the aim of providing a single point solution for such dual purpose application, There are conventional chiller heaters available using absorption technology but these chiller heaters are consume energy like Hot water generator plus absorption chillers with no energy saving. Only advantage will be is that it is single equipment.

Thermax has developed a product that can provide simultaneous chilling and heating using its Vapour absorption technology with 40% saving in heating energy.

In these products 40% of Heat required for generating hot water is recovered from low temperature chilled water. Remaining 60% is recovered from external heat source. Thereby, 40% reduction in direct external heat source can be achieved for heating hot water as compared to conventional hot water generator. Additionally refrigeration is also generated simultaneously.

Thermax Vapour absorption Chiller heater generates chilling and heating simultaneously in a single unit using Steam / Fuel firing / Exhaust gases / Hot water as heat source.

Product patent application has been filed for this product in India as well as major export markets.

12. High efficiency Chiller/Heater



High efficiency Chiller/Heater.



Below scheme shows a typical example of the energy balance of the Chiller/Heater:

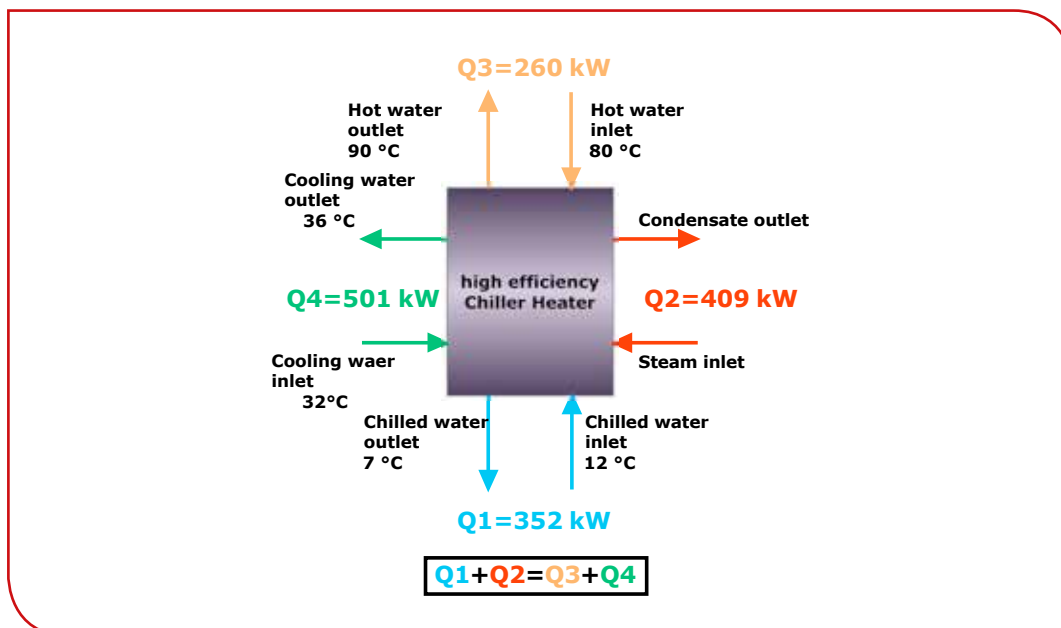

The scheme of operation of chiller heater as compared to conventional hot water generator has been explained using schematic diagrams as given above.

40% of fuel consumption required for hot water generation (Q3) is recovered from the refrigeration cycle. Hence not only does the fuel consumption for heating is reduced, the heat rejection in Cooling tower (Q4) also reduces.



High efficiency Chiller/Heater is flexible enough to be used for production of chilled water only, hot water only or chilled water and hot water simultaneously.

In the absence of heating load the chiller-heater can run with a turndown of 20-100 % cooling capacity. This doesn't require change over of mode of operation.

When the cooling load goes down, the heating capacity delivered will also reduce. The maximum heating capacity in simultaneous mode is 75-80% of the prevailing cooling load.

When the cooling load is in the range of 90-100% of rated, the chiller heater can deliver heating with a turn down of 20-100% of rated.

In the absence of cooling load (0%), chiller-heater can produce 100% heating capacity only after change over to heating mode.

Picture below shows schematically the advantages of the high efficiency Chiller/Heater

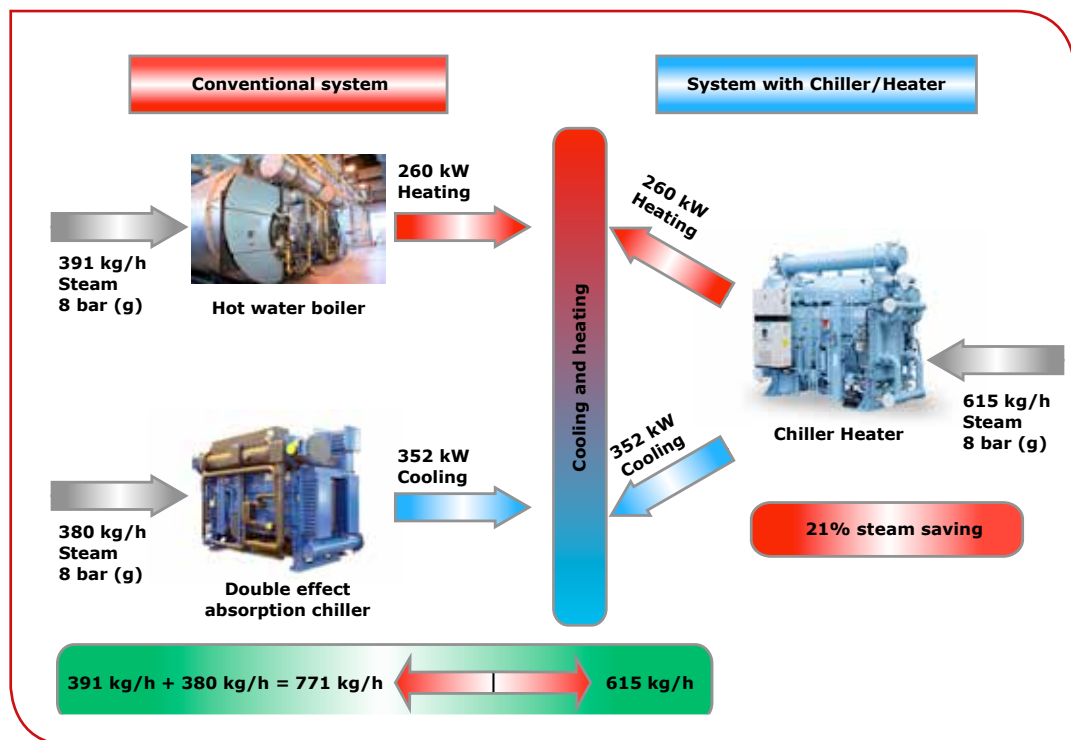

In the above example the solution utilizing a high efficiency Chiller/heater is achieving a steam saving of 21% respect to a conventional solution utilizing a boiler and a separate absorption chiller.

Other advantages of this type of machine are the small footprint, the simple hydraulic connection required and the extremely simplified regulation.

12. High efficiency Chiller/Heater



Also, as already mentioned, there is another important advantage on the cooling system of the machine, as illustrated in below scheme:

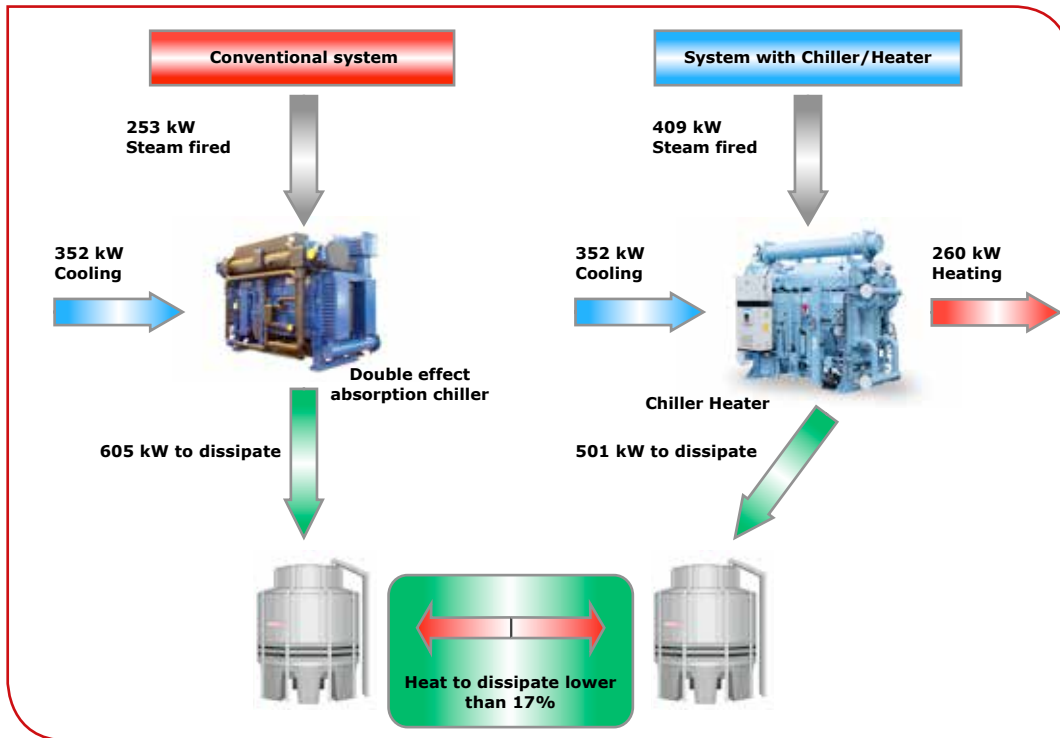

At same cooling capacity and same heating capacity, the high efficiency Chiller/heater dissipate a quantity of heat which is about 17% lower than the one dissipated by a conventional system. Hence this is reducing substantially the size of the cooling tower and of the entire cooling system.

POSSIBLE HEAT SOURCES:

Steam 3,0 bar(g)-10 bar(g)
Superheated water 145 °C-180 °C
Direct fired with gas burner
Exhaust gases 350 °C-600 °C

CAPACITY RANGE:

Cooling capacity between 350 kW and 12,3 MW
Heating capacity between 100 kW and 9 MW

TEMPERATURE RANGE:

Cooling 0-30 °C, $\Delta T=30$ °C max.
Heating 30 °C-90 °C, $\Delta T=5-50$ °C max.



A series of horizontal dotted lines for writing notes, with a large, faint watermark of the number '1' in the lower-left quadrant.



3B/3D series Triple effect

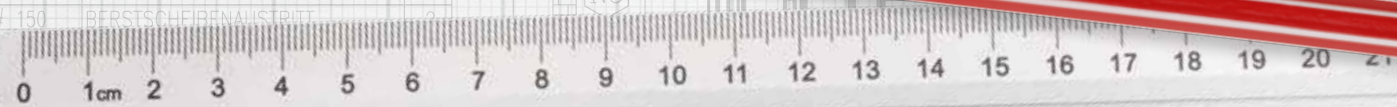
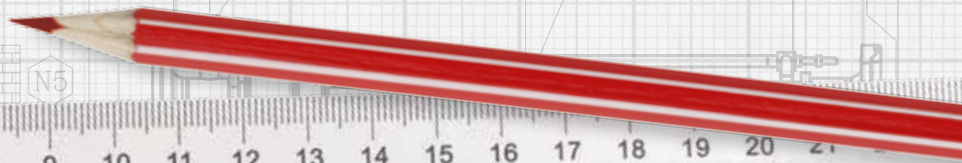
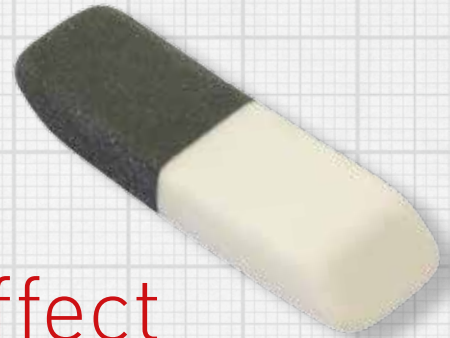

NPT(F)	KÜHLWASSER-ENTLEERUNG	1
ANSI # 300	DAMPFEINTRITT	1
ANSI # 300	KONDENSATAUSTRITT	1
ANSI # 150	BERSTSCHIEBENAUSTRITT	1
ANSI # 150	BERSTSCHIEBENAUSTRITT	2

Typ
3B A

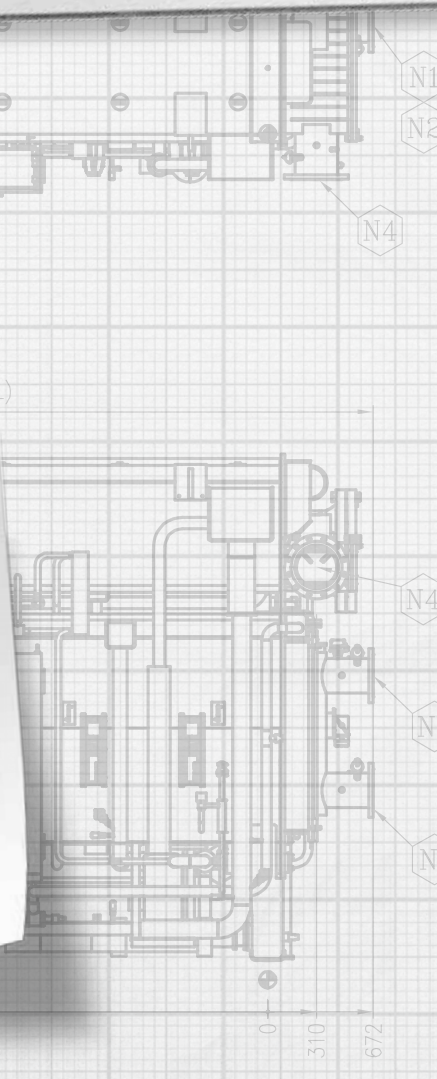
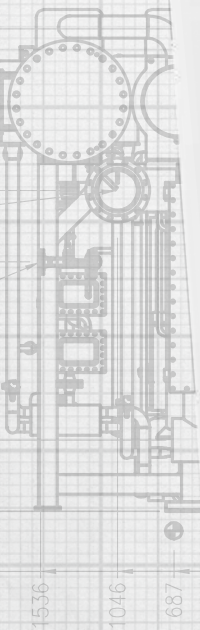
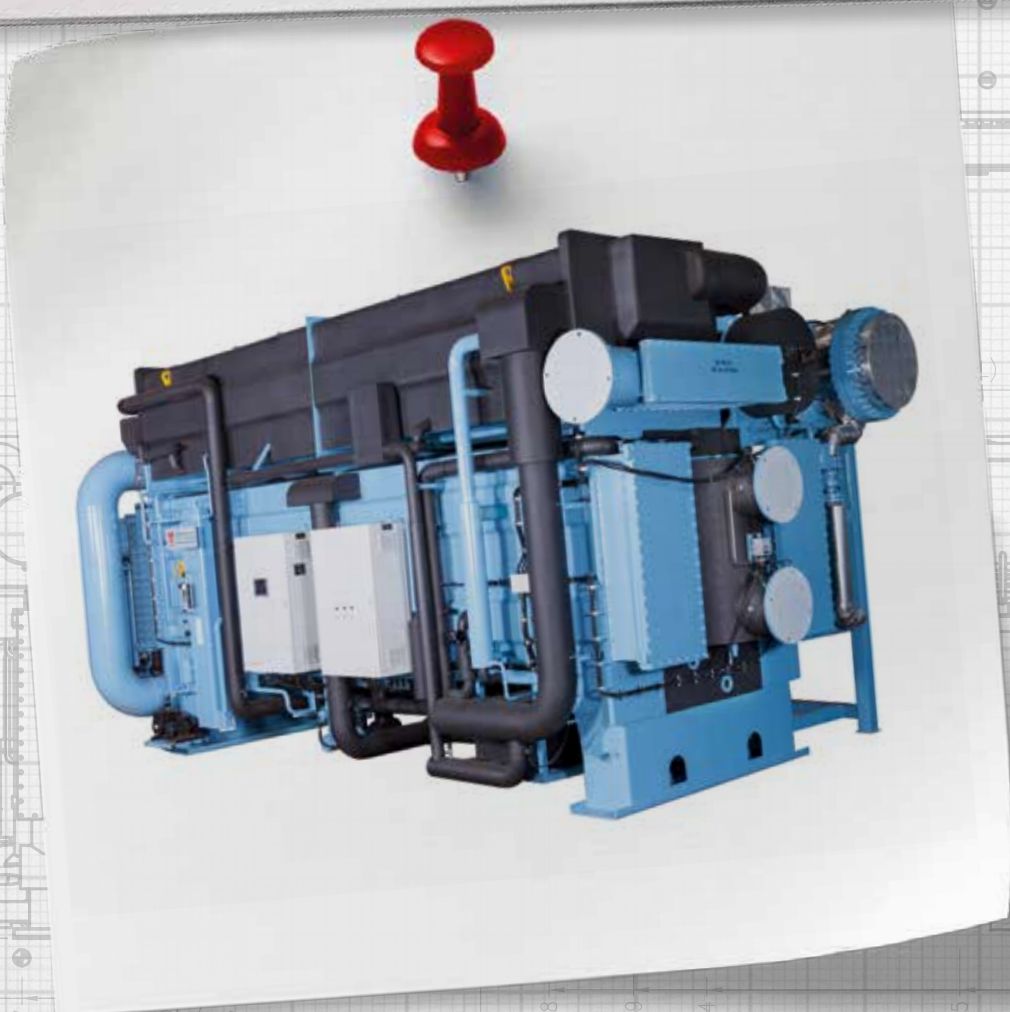

FREIRAUM ZUM ZIEHEN DER ROHRE
(NUR AN EINER DER BEIDEN STIRNSEITEN ERFORDERLICH)



NEW

13. 3B/3D SERIES:

Brand new series featuring a triple effect cycle, with three generators and low, medium and high temperature, fired with high grade heat sources like steam (3B) or exhaust gases (3D).

This series represents the highest development reached by an absorption chiller and it shows the highest values of efficiency in the market. Thermax has become the first manufacturer to have developed a triple effect machine and to have launched it in the market.

Triple effect machines have an average COP between 1,75 and 1,85. This means cooling capacities between 23 and 28% higher with same heat input respect to double effect machines.

Triple effect machines operate with high temperature generator temperatures between 180°C and 210°C. This make them the first LiBr absorption chillers running with a positive pressure, in a range between 2,5 and 4,5 bar (g).

As the number of effects increase, not only internal temperatures are raising, but at same concentration level also corrosion rate is increasing.

For such reasons the technical challenges given by a triple effect machine are extremely complex: the complexity of the working cycle (considering the presence of three generators and many other heat exchangers), the higher working pressures (more rugged construction required) and the higher corrosion potential of LiBr solution.

In order to give answer to all above challenges Thermax has further developed and refined the modified series cycle already used in its double effect machines. With this new cycle the couple temperature/concentration of the solution never shows both maximum values at the same time. In high temperature generator where the temperature is the highest, the concentration will be the lowest. At same time where concentration is higher in low temperature generator, temperature is lowest.

In a Thermax triple effect machine developed with this concept, solution concentration in high temperature generator is usually lower than the same one in a double effect machine.

Capacity range of steam fired machines: 175 kW-3,5 MW

Capacity range of exhaust gases fired machines: 175 kW-1,8 MW

Nominal steam pressure between 15 bar(g) and 25 bar(g)

Exhaust gases temperatures between 400 °C and 600 °C

COP: ca. 1,75-1,85

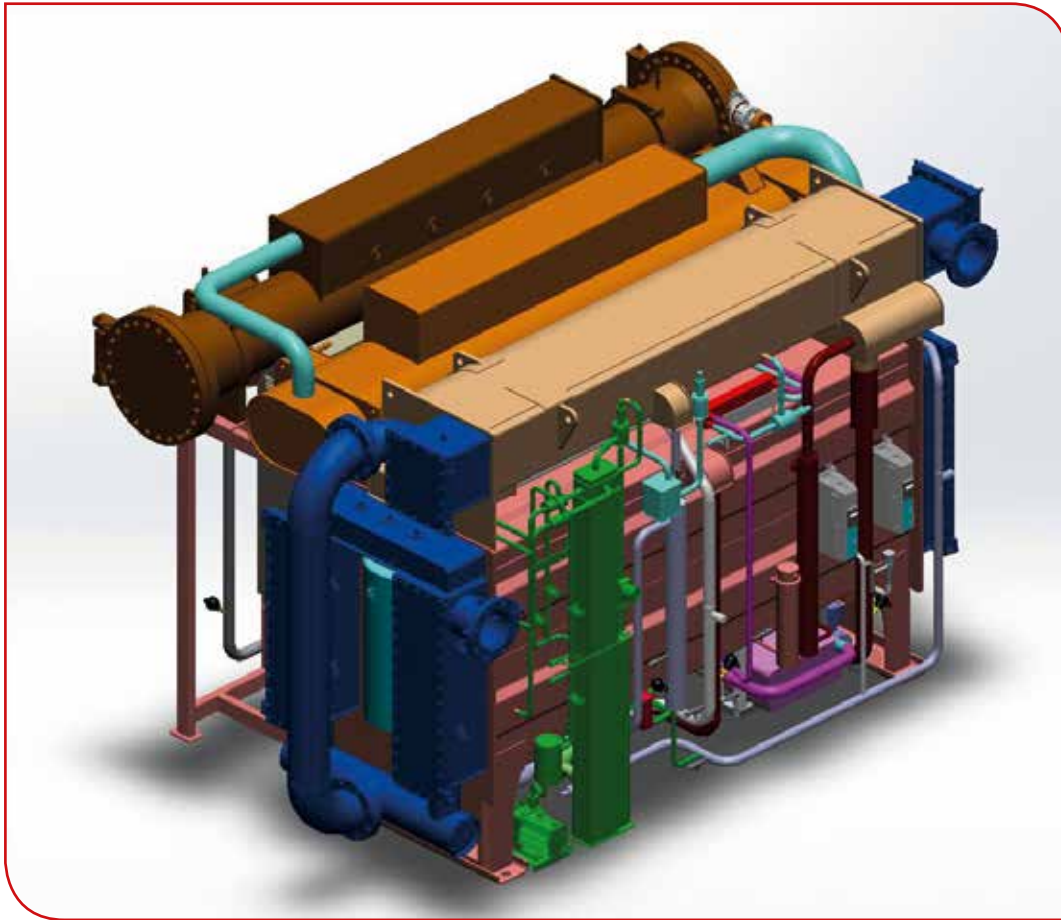

3D view of a triple effect machine of 3B series

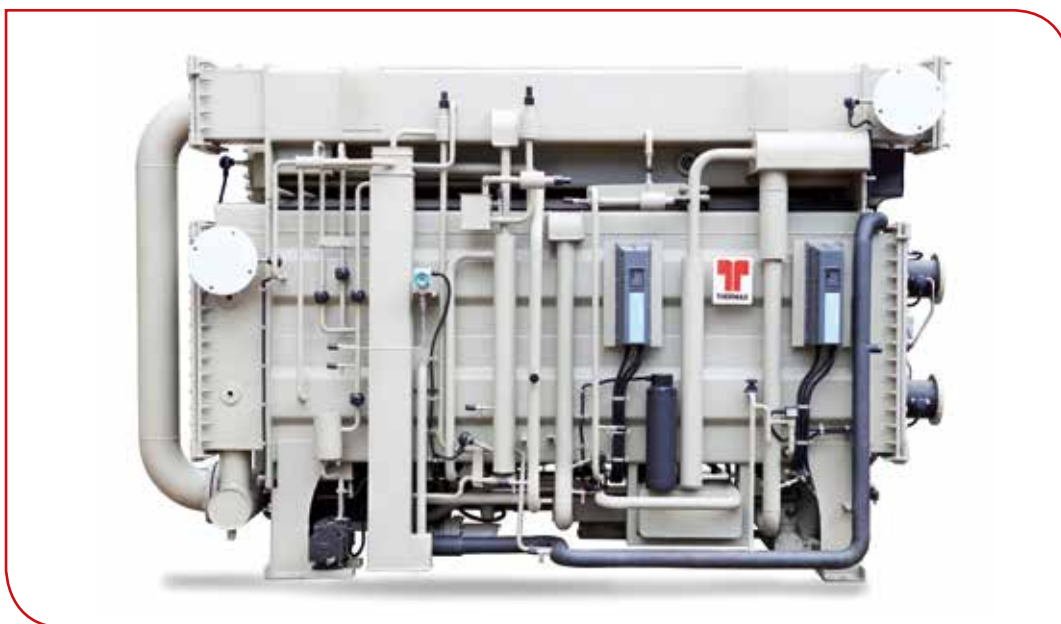

Picture of a triple effect machine of the 3B series

Below pictures show two real triple effect machines of 3B series installed in a plant room.





3B/3D POSSIBLE APPLICATIONS:

- Chemical industry
- Food industry
- Automotive industry
- Processes using steam discharge from turbine in cogeneration plants or in power plants
- Exhaust gases from gas engines in large cogeneration plants
- Industrial steam or waste heat available at the required temperature level

NECESSARY DATA TO PREPARE AN OFFER:

- Cooling capacity required (or alternatively the available heat capacity)
- Chilled water inlet/outlet temperatures
- Cooling water inlet/outlet temperatures
- Steam pressure (3B)
- Exhaust gases temperature (3D)
- Exhaust gases flow (in kg/h) (3D)
- Allowable Pressure drop in exhaust furnace (3D)



A series of horizontal dotted lines for writing notes, with a large, faint watermark of the number '1' in the lower-left quadrant.



Heat pumps

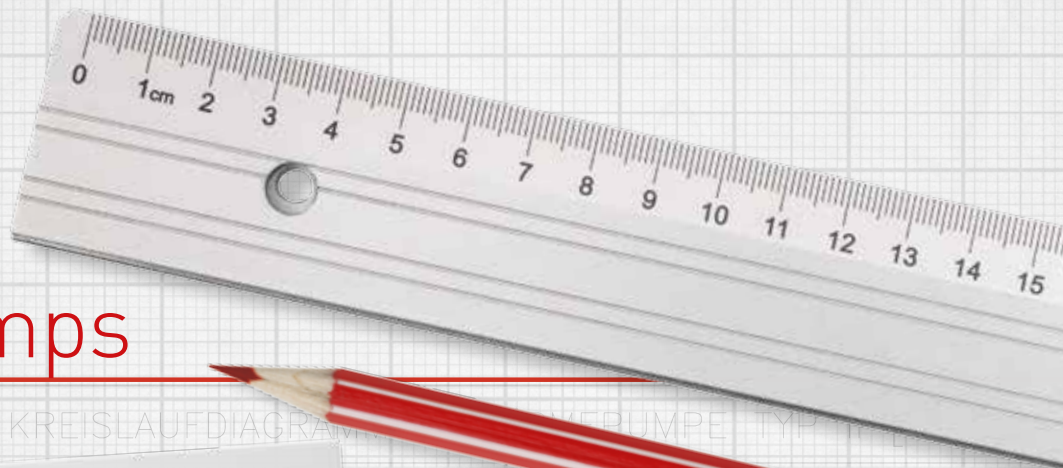

KREISLAUFDIAGRAMM DER WÄRMEPUMPE TYP 1000

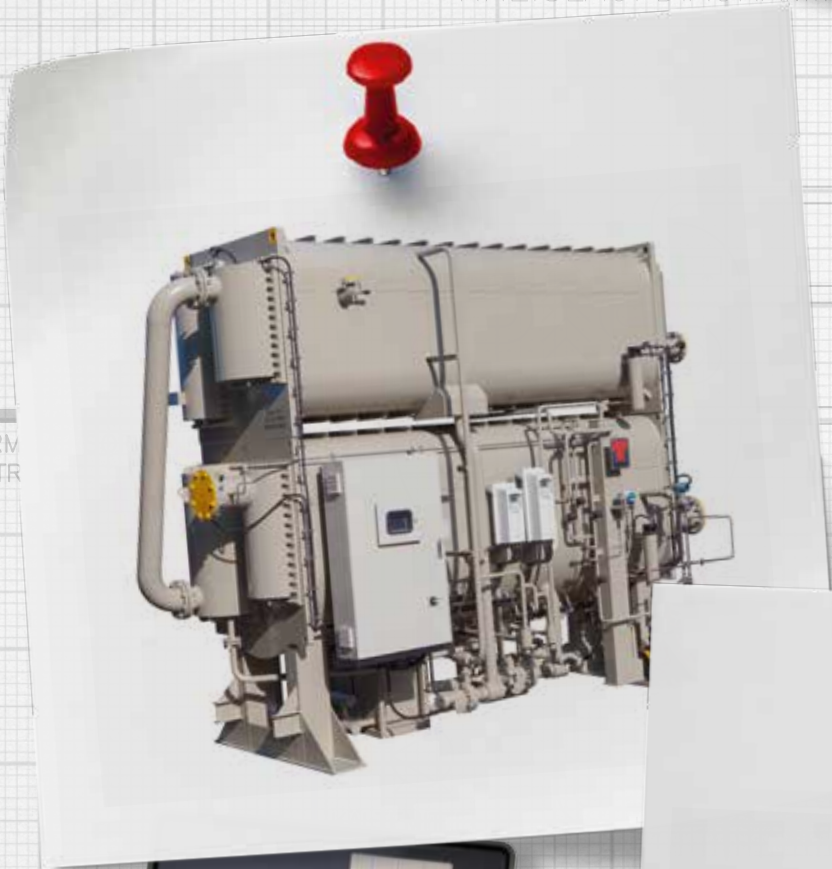

WÄRM
EINTRIT

HEISSWASSER
AUSTRITT

HEISSWASSER
EINTRITT



KÜHLWASSE
AUSTRITT

KÜHLWASSER
EINTRITT



WÄRMETRÄGER

WÄRMETRÄGER ABSORBENT
PUMPE

LÖSUNGSWÄRMETAUSCHER



14. HEAT PUMPS

Further to absorption chillers for cooling and chilled water production, the absorption technology can be applied also on heat pumps, in order to achieve production of hot water.

TYPE I HEAT PUMPS

Below picture shows the different temperature levels at which typically an absorption chiller and an absorption heat pump work:

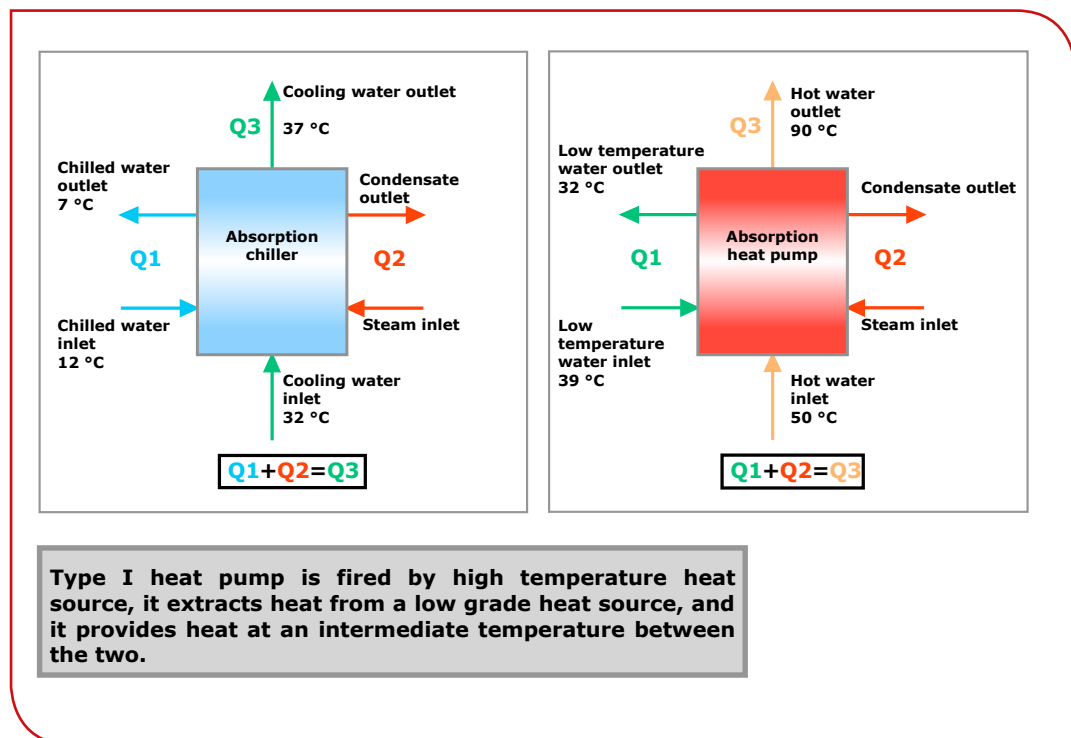

The schematic diagram shown in following picture illustrates a typical energy balance of a Type I absorption heat pump.

As you can see, for each 1,7 kW of hot water given to the final user, 0,7 kW are generated for free. This means a saving of 40% respect to the use of conventional hot water boilers.

14. Heat pumps

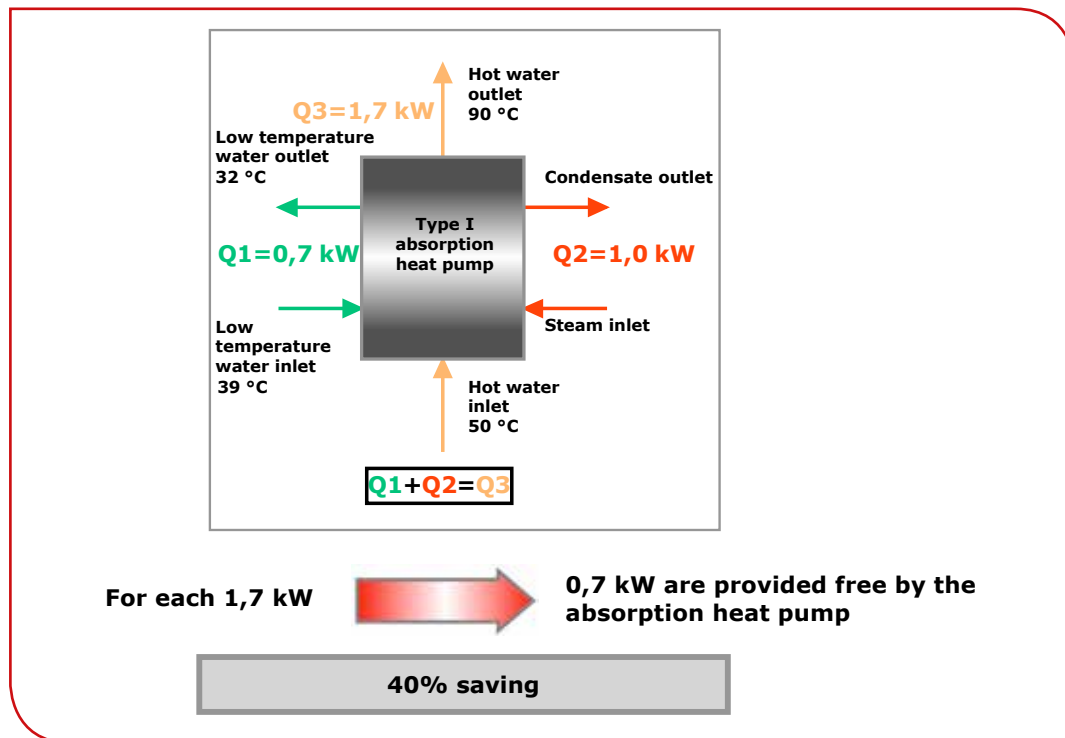

The higher is the temperature of the low temperature heat sink where the heat is extracted from, the higher is the hot water temperature that is possible to achieve.

Absorption heat pumps are designed on a case to case basis depending upon the specific request of the customers.



TYPE II HEAT PUMPS

Below scheme illustrates the major differences between a Type I heat pump and a Type II heat pump:

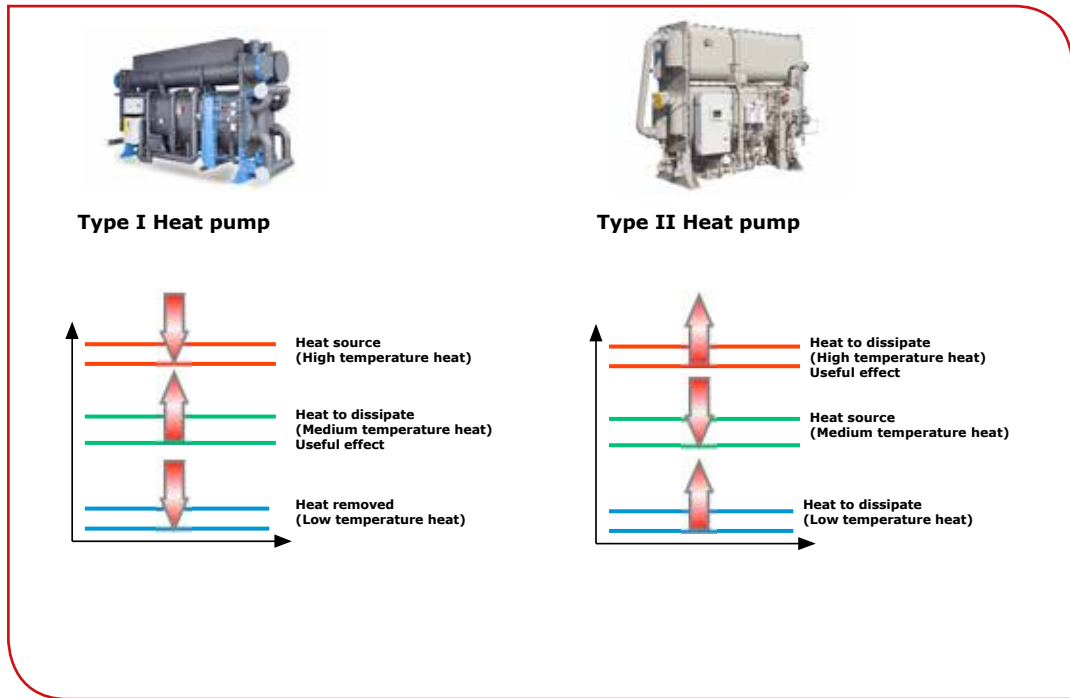

As it is shown, the position of the rejected heat (which represents the useful effect) is substantially different in the two cases. While in Type I heat pump the heat to be dissipated (hot water going to user) is at a medium temperature level, in Type II heat pump it is at the highest temperature level.

Similarly, heat source in Type I heat pump is at the highest level, while in Type II heat pump is at the medium level. Also Type II requires some heat to be dissipated at low temperature. It means Type II heat pump requires a cooling tower just like an absorption chiller.

Differences between the two heat pumps are summarized in below table:

Type I heat pump Vs Type II heat pump	
Type I heat pump	Type II heat pump
Machine is fired by an heat source at high temperature. Heat is extracted by a low temperature heat sink and heat at an intermediate temperature between the two is released to final users.	Machine is fired by an heat source at a medium temperature. Part of this heat is dissipated at low temperatures (cooling towers) while part of it is released to final users at higher temperatures.
Efficiency approx. 1,7	Efficiency approx. 0,48
Typical temperature profile: Low temperature heat sink: 40 °C-35 °C High temperature heat source: superheated water at 180 °C-160 °C or steam at 6-8 bar (g) Hot water available to users: 60 °C-90 °C	Typical temperature profile: Medium temperature heat source: hot water at 110 °C-100 °C Cooling water: 30 °C-36 °C Hot water available to users: 150 °C-160 °C

14. Heat pumps



In below scheme it is shown the typical energy balance of a Type II heat pump:

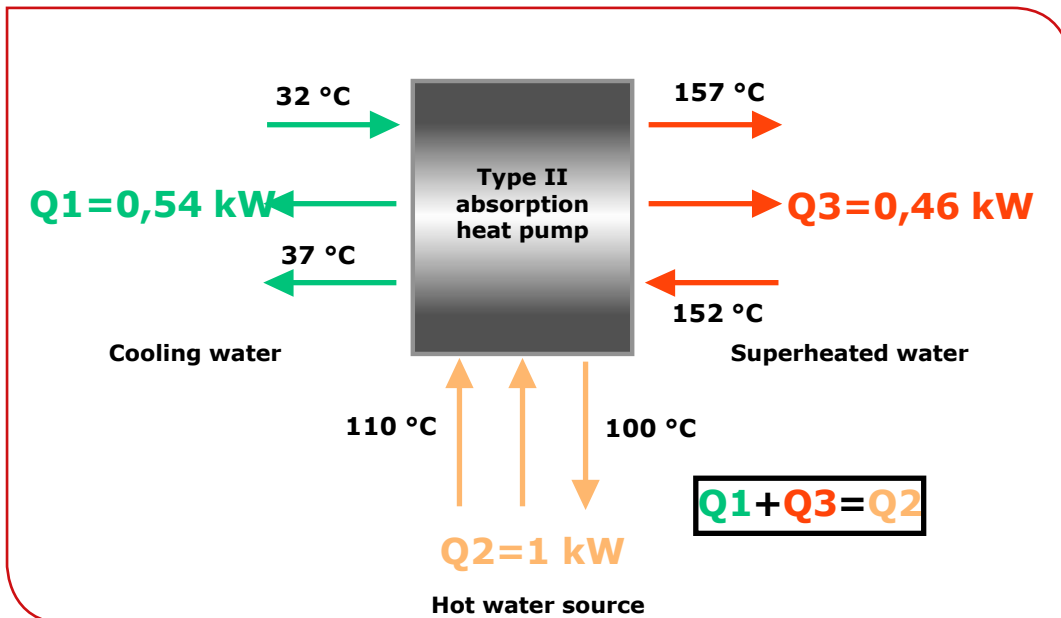

Picture below shows a Type II heat pump:



TYPE I HEAT PUMP

Low temperature heat sink (30 °C-60 °C)

- Water from cooling towers
- Condensate from industrial processes
- Geothermal water

Capacity range between 250 kW and 40 MW

COP 1,65-1,75

Hot water released to users:

- Hot water 35 °C-90 °C
- ΔT 55 °C max.

High temperature heat source

- Dry saturated steam (1-10 bar(g))
- Superheated water (130 °C-180 °C)
- Exhaust gases (275 °C-600 °C)

TYPE II HEAT PUMP

Medium temperature heat source (80 °C-120 °C)

- Hot water from process
- Geothermal water
- Condensate from steam turbines

High temperature heat released to users:

- Dry saturated steam (1,0 bar(a)-4,0 bar(g))
- Superheated water (110 °C-155 °C)

Capacity range between 500 kW and 10 MW

COP 0,45-0,5

Type I heat pump installed in Copenhagen (Denmark)



NEW

15. LOW TEMPERATURE MACHINES

All absorption chillers shown in the catalogue can be equipped with a special kit (called "Low Temperature kit") in order to achieve chilled water outlet temperatures between 3,5°C and -5°C .

In a traditional absorption chiller the minimum chilled water outlet temperature achievable is limited by the fact that the refrigerant used by machines is water. In order to avoid the freezing of refrigerant the minimum chilled water outlet temperature achievable by a traditional machine is 3,5°C.

Thanks by the technology developed by Thermax it is possible now to achieve lower temperatures of chilled water outlet: as of now the limit is set at -5°C.

A precise and sophisticated control system injects a small quantity of LiBr solution into refrigerant: in such a way the contaminated refrigerant doesn't freeze at 0°C anymore and it is possible to achieve lower chilled water temperatures. The system is capable to determine the concentration of LiBr solution in the refrigerant and it maintain this concentration between a narrow range: enough to avoid refrigerant freezing but also to avoid excessive heat transfer loss due to too much LiBr solution in refrigerant.

POSSIBLE APPLICATIONS:

- Food industry
- Cheese industry
- Milk industry
- Beer industry
- Refrigeration plants in order to reduce the consumption of ammonia chillers

A series of horizontal dotted lines for writing notes, with a large, faint watermark of the number '11' in the lower-left quadrant.



A series of horizontal dotted lines for writing notes, with a large, faint watermark 'TT' in the lower right quadrant.



A series of horizontal dotted lines for writing notes, with a large, faint watermark of the number '11' in the lower-left quadrant.



A series of horizontal dotted lines for writing notes, with a large, faint watermark 'TR' in the lower right quadrant.



Riportiamo di seguito un estratto di alcune installazioni in Italia eseguite in collaborazione con TRANE ITALIA srl. THERMAX può vantare circa duecento unità installate in Italia e quasi 500 in tutta Europa. Per l'elenco completo rivolgersi agli uffici di Thermax o Trane Italia.

- Ergom Melfi
- Fiat Sevel
- Università di Fisciano
- Università di Potenza
- Ferrero (stabilimenti di Alba, Balvano e S.Angelo Lodigiano)
- Ospedale di Merano
- Ospedale di Cittadella
- Ospedale di Camposanpiero
- Ospedale Este
- Humanitas Rozzano
- Policlinico di Milano
- AGAP Maserati
- Sanofi (stabilimenti di Brindisi e Scoppitto)
- Pasta Baronina
- Ospedale di Merate
- Ospedale di Feltre
- Ospedale Fatebenefratelli
- Ospedale S.Carlo Borromeo
- Ospedale Cardarelli
- Aeroporto Marco Polo Venezia
- Aeroporto G.Marconi Bologna
- Patheon
- Sigma Tau
- Eskigel
- Luxottica
- Albea Cosmetics
- Ospedale di Tricase
- Hexion
- Siemens
- Alpla
- Veritas
- Peroni



A series of horizontal dotted lines for writing, with a large, faint watermark 'TF' in the bottom right corner.

Thermax Europe Ltd., UK

UK Thermax Europe Ltd. 2 Studio Court

Queensway Milton Keynes

Bletchley MK2 2DG

Tel: +44 1908 3789 14

Fax: +44 1908 3794 87

E-Mail: info@thermax-europe.com

India factory

D-13 MIDC Chinchwad

Pune 411 019

Tel: +91 20 274759 41

Fax: +91 20 274759 07

E-Mail: acdmktg@thermaxindia.com

www.thermaxglobal.com

China factory

Thermax (Zhejiang) Cooling & Heating Co. Ltd.

A8-511, Jiahua Business Center

808 Hong Qiao Road

Shanghai 200030

Tel: +86 21 64483996

Fax: +86 21 64483997

www.thermax-china.com

Distributed by:



WWW.THERMAX-EUROPE.COM

