5G Small Series

Absorption chillers

Hot water fired - Single effect

45 - 800 kW



TF
THERMAX

INTRODUCTION

WORKING PRINCIPLE

Absorption chillers operate on the basis of three well known physical phenomena:

- a) When a liquid evaporates (or boils) it absorbs heat, and when it condenses it gives up heat.
- b) The evaporating temperature of a liquid is a function of the pressure. I.e. as the pressure decreases so does the boiling point.
- c) Some chemicals that have a strong affinity to absorb another.

In a conventional, mechanical vapor compression cycle, the refrigerant evaporates at low temperature producing cooling. It is then compressed mechanically to an elevated pressure, then it is cooled and condensed. Most of the machines have a compressor powered by an electric motor. In an absorption chiller the evaporator and condenser are essentially the same, but a chemical absorber and a thermal generator replace the compressor, with a small pump to provide pressure change. As a pump requires much less power than a compressor.

The functions described operate in an absorption chiller as follows:

1. Refrigerant water evaporates in a deep vacuum "6 mmHg absolute" to a lower sealed shell at a temperature of 3,7°C. The chilled water circuit tube bundle is thereby cooled. The left hand side section in which the tube bundle is located is called the EVAPORATOR.

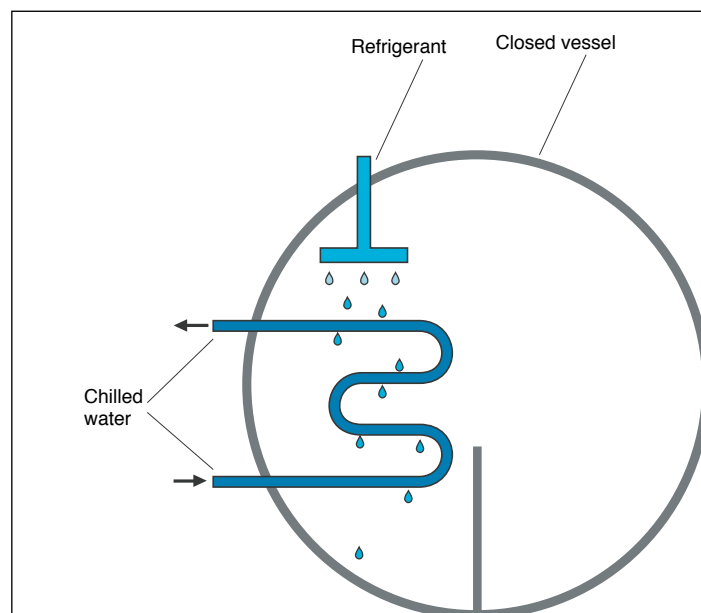

2. The right hand side location houses the ABSORBER section. In this section an aqueous concentrated solution of lithium bromide is sprayed. The solution is hygroscopic, maintaining the shell vacuum and the weak solution of lithium bromide is collected in the base. The process of absorption produces heat and this is removed by the cooling water tube bundle.

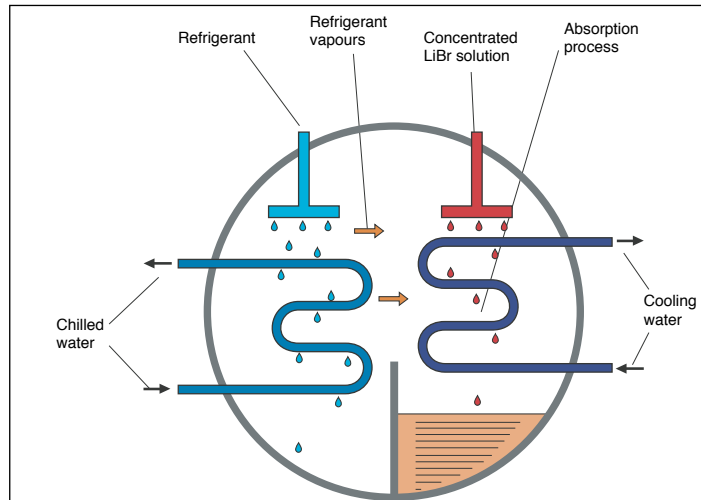

3. Hygroscopic properties of the aqueous solution of lithium bromide depend on two factors:
- i) Temperature: the affinity between lithium bromide and water increases as temperature decreases.
 - ii) Concentration: as this reduces its hygroscopic effect decreases.

The collected diluted solution of lithium bromide has to be re-concentrated. It is pumped to a dedicated vessel called GENERATOR. Heat is applied through a tube bundle to vaporize the water from the diluted solution. Hot water, steam or the direct combustion of fuel is used depending on type of machine.

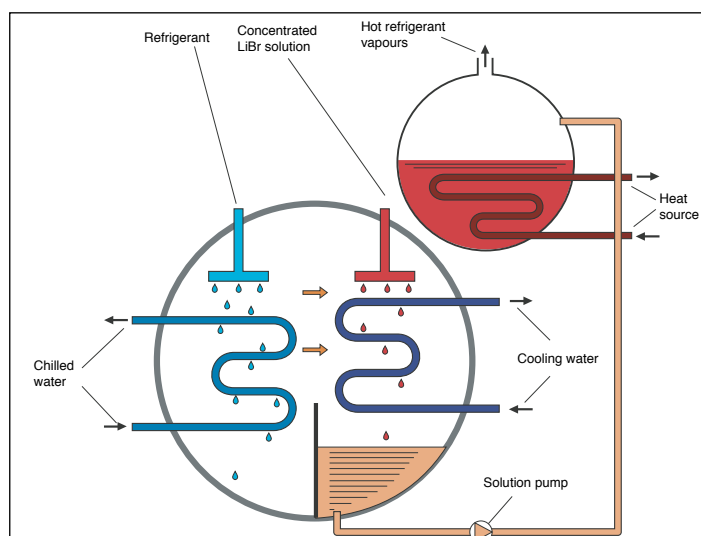

- The water vapours are pumped to another heat exchanger called CONDENSER where they are condensed by a cooling water flow (the same water that is flowing in the absorber). This condensed water is used as refrigerant to be sprayed in the evaporator to generate the cooling effect. Therefore, the working cycle of the machine is completely closed.

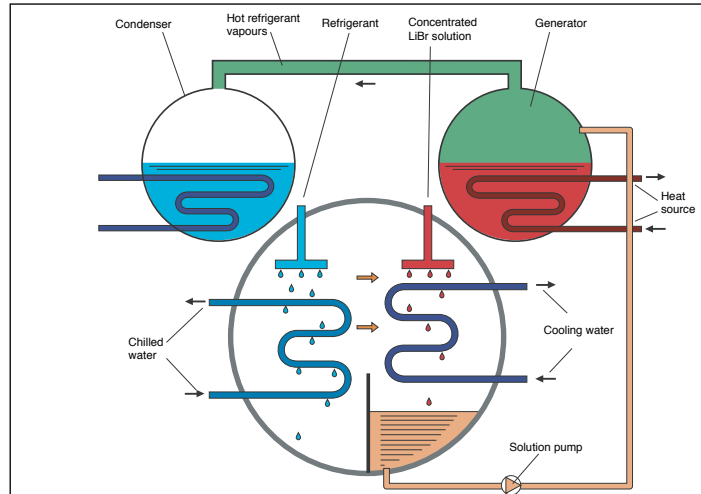



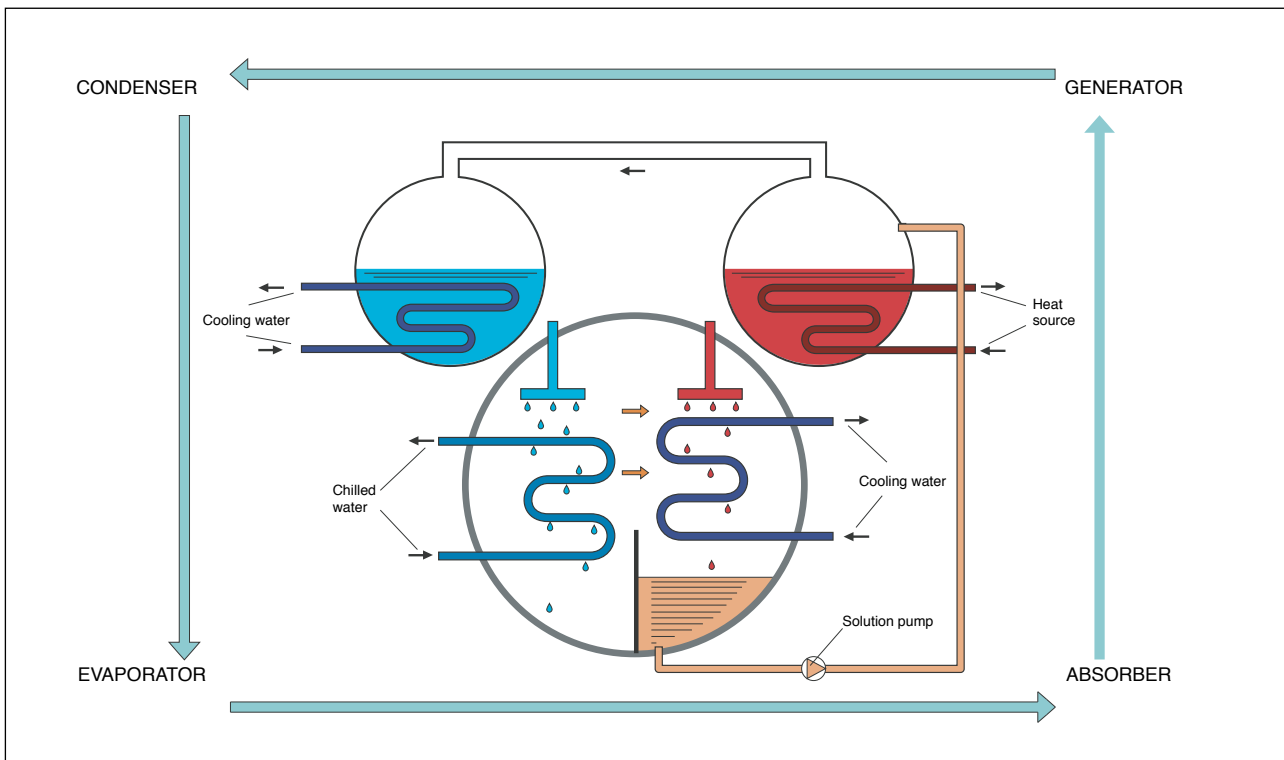

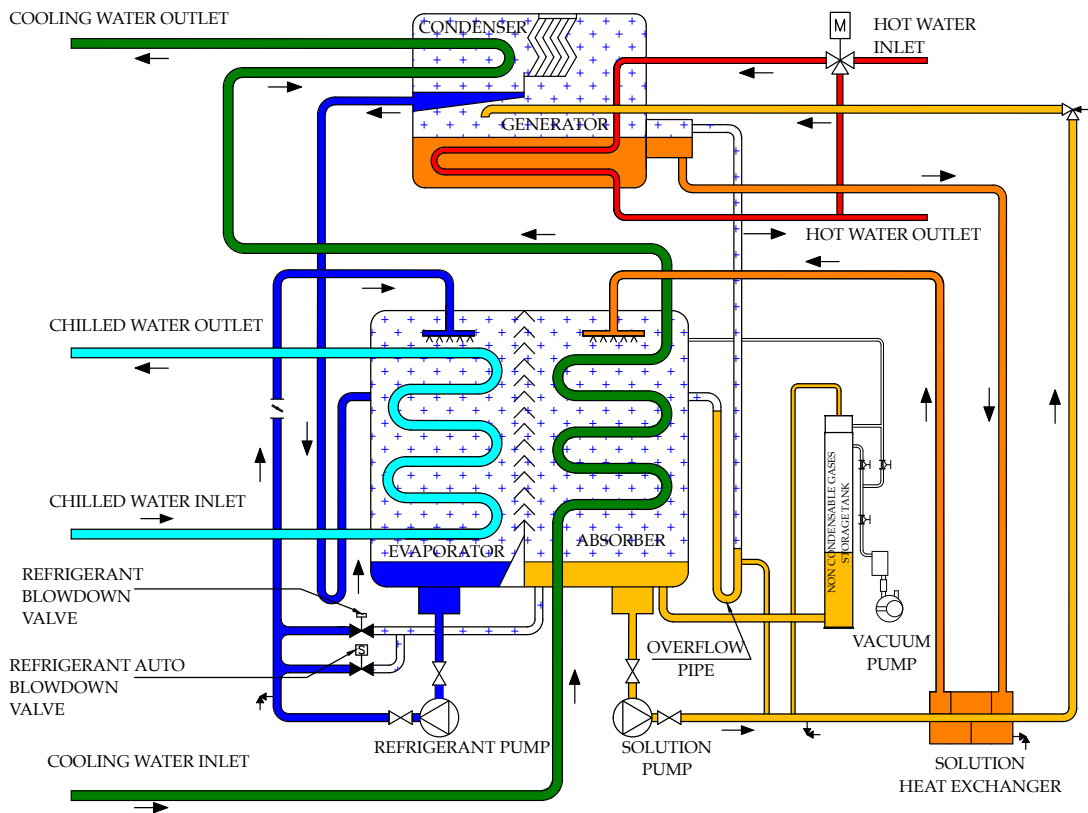

- Basic working cycle for a single effect absorption chiller.



CYCLE DIAGRAM



	CONCENTRATED SOLUTION		REFRIGERANT LIQUID		CHILLED WATER		HOT WATER
	DILUTE SOLUTION		REFRIGERANT VAPOUR		COOLING WATER		

CYCLE DESCRIPTION

Generator

Inside this heat exchanger the dilute LiBr solution is warmed up by hot water sprayed on the tubes. Thanks to the heat, the solution starts boiling and its concentration and temperature increase. Therefore, at the outlet of the generator both the concentrated solution and refrigerant vapors are available.

Recovery heat exchanger

The hot concentrated solution coming from the generator is sent to the absorber after that it is passed through a recovery heat exchanger. Inside this heat exchanger, the concentrated solution preheats the dilute solution coming from the absorber and going to

the generator. The concentrated solution temperature decreases. The use of this heat exchanger leads to an overall increase of the efficiency of the machine.

Absorber

Once the solution has reached the absorber, it is sprayed onto the tube bundle where the cooling water is owing on the inside. The concentrated solution absorbs all the vapors generated in the evaporator section, so that the pressure inside the shell is kept constant. The LiBr solution however gets diluted. From here the solution is pumped to the generator where it is concentrated again by the heat source used in the machine. As already seen before, cooling water is owing inside absorber tubes, since the absorption of the water in the LiBr solution is an exothermic process. The heat generated in this process is called dilution heat. If this heat is not removed from the machine, the solution temperature will increase and consequently the solution affinity towards the water will decrease. Thus, the absorption process will become less effective.

Condenser

The refrigerant vapors coming from the generator enter the condenser where they are condensed by the cooling water circulating inside the tubes. The liquid refrigerant collects at the bottom of the condenser and it is sent to the evaporator.

Evaporator

The refrigerant coming from the condenser enters the evaporator which is at a lower pressure than the condenser; for this reason the refrigerant ash cools down to 3,7°C that is the boiling temperature corresponding to the pressure inside the shell and then it falls onto the evaporator tubes. Once it is collected at the bottom, it is pumped by the refrigerant pump to the distribution trays of the evaporator, from where it drops onto the tube bundles due to the gravity. As the refrigerant contacts with the tubes, it evaporates taking the heat away from the water circulating inside the tubes. This water is so cooled down to the required temperature.

DESIGN PHILOSOPHY

The design philosophy of Thermax 5G Small series machines are spread over four categories:

➔ Reliability	➔ SS 430 Ti tubes in generators and solution heat recovery heat exchanger of plate type with SS plates. ➔ Gravity feed distribution system for LiBr and refrigerant.
➔ Efficiency	➔ Plate type solution heat exchanger to enhance efficiency of machine and reduce footprint.
➔ Monitoring	➔ PLC based monitoring and control ➔ Modbus, Profibus and Ethernet connectivity available on request ➔ Vacuum seal isolation valves on solution and refrigerant pump
➔ Maintenance	➔ Marine water boxes for cooling water ➔ Non toxic corrosion inhibitor

MAIN FEATURES

- ❖ Double shell design: the upper shell (including the condenser and the generator) and the lower shell (including the evaporator and the absorber).
In case of single shell design, the evaporator is on top of the absorber. Any non condensable gas released in the absorber section will rise up and there is a possibility that these gases are trapped below the bottom of the separation trap, and they can given time corrode the separation plate. Whereas in case of a double shell design, the evaporator and the absorber are located side by side, and therefore the possibility of the separation plate corrosion is eliminated. This shell design type calls also for higher chances of internal short circuiting as when the water level in the evaporator is very high (and consequently the solution concentration is very high) the refrigerant can directly flow into the absorber and the concentration of the solution is reduced.
- ❖ Completely factory assembled and wired.
- ❖ Leak tested in every part: upper and lower shell, solution heat exchanger, solution and refrigerant canned pumps, vacuum pump and purge assembly.
- ❖ PLC based control.
- ❖ LiBr solution, refrigerant, corrosion inhibitor and octyl alcohol separately provided to be charged on site.

-
- ❖ Nitrogen is charged into the machine at a pressure slightly higher than atmospheric prior to shipping, in order to avoid air entering the machine and damaging the internals.
 - ❖ Lifting lugs provided on each side of the machine.

MECHANICAL FEATURES

LOWER SHELL

The lower shell assembly houses the evaporator and the absorber sections. They are shell and tube type heat exchangers, housed in a common fabricated carbon steel shell.

- ❖ Stainless steel eliminator plates between evaporator and absorber, in order to permit only to the refrigerant vapors to flow to the absorber, retaining the liquid in the evaporator.
- ❖ Finned and thin wall DLP (Deoxidized Low Phosphorous) copper tubes in the evaporator. In DLP copper the oxygen is removed and the phosphorous content is less than 0,005 ppm. The presence of phosphorous greater than 0,005 ppm in the tubes of the absorption machines can result in "Stress Corrosion Cracking". At a microscopic level, stress corrosion cracking takes place on the external surface of the tubes by the attack of a salt (e.g. LiBr) on the grain boundary.
- ❖ Mini-finned and thin wall DLP (Deoxidized Low Phosphorous) copper tubes in the absorber. In DLP copper the oxygen is removed and the phosphorous content is less than 0,005 ppm. The presence of phosphorous greater than 0,005 ppm in the tubes of the absorption machines can result in "Stress Corrosion Cracking". At a microscopic level, stress corrosion cracking takes place on the external surface of the tubes by the attack of a salt (e.g. LiBr) on the grain boundary.
- ❖ All the tubes fitted in the respective tube sheets are duly expanded for the correct fit. All the tubes are individually accessible and replaceable from either end of the chiller.
- ❖ Carbon steel tube sheets.
- ❖ Carbon steel bolted type evaporator headers fully removable at either side of the machine, for easy access to the tube bundle. Headers are provided with flanged nozzles.
- ❖ Carbon steel marine type absorber headers, for an easy access to the tube bundle without need of lifting systems to support the header.
- ❖ Counter flanges provided as a standard feature with the unit.
- ❖ Plugged vents and drain connections provided for the water boxes.

-
- ❖ Sight glasses respectively on the evaporator and the absorber shells. These glasses are used to monitor the refrigerant and the solution levels in the evaporator and the absorber for an easy and user friendly operation, since through them it is possible to monitor the correct working of the machine.

UPPER SHELL

The upper shell assembly houses the condenser and the generator sections. They are shell and tube type heat exchangers, housed in a common fabricated carbon steel shell.

- ❖ Stainless steel eliminator plates between condenser and generator, in order to permit only the refrigerant vapors to flow to the condenser; the retained solution drops to the bottom of the generator, thus reducing the chance for the solution contaminating the pure refrigerant.
- ❖ Enhanced and thin wall DLP (Deoxidized Low Phosphorous) copper tubes in the condenser. In DLP copper the oxygen is removed and the phosphorous content is less than 0,005 ppm. The presence of phosphorous greater than 0,005 ppm in the tubes of the absorption machines can result in "Stress Corrosion Cracking". At a microscopic level, stress corrosion cracking takes place on the external surface of the tubes by the attack of a salt (e.g. LiBr) on the grain boundary.
- ❖ Mini-finned SS 430 Ti tubes in the generator. SS 430 has similar thermal expansion coefficient to carbon steel of tube plates, allowing to use straight tubes without generating mechanical stress and without using "U" type tubes or complicated mobile supports. Also SS 430 Ti is more reliable respect to stress corrosion phenomena.
- ❖ Flow boiling type generator for higher heat transfer efficiency.
- ❖ Straight tubes in the generator for easy maintenance.
- ❖ All the tubes fitted in their respective tube sheets are duly expanded for the correct fit. All the tubes are individually accessible and replaceable from either end of the chiller.
- ❖ Carbon steel tube sheets.
- ❖ Carbon steel bolted type generator headers fully removable at either side of the machine, for easy access to the tube bundle. Headers are provided with flanged nozzles.
- ❖ Carbon steel marine type condenser headers, for an easy access to the tube bundle without need of lifting systems to support the header.
- ❖ Counter flanges provided as a standard feature with the unit.
- ❖ Plugged vents and drain connections provided for the water boxes.

HEAT EXCHANGER

The units are provided with one regenerative heat exchanger to increase the efficiency of the cycle. The heat exchanger is plate type one, with brazed stainless steel plates, designed for the maximum heat exchange with the minimum pressure loss. The use of plate heat exchanger leads also to a more compact design of the unit.

PURGE ASSEMBLY

- ❖ The units are provided with a purge system which is able to continuously and automatically remove non condensable gases from the inside of the machine, storing them into the storage tank. This one is divided in two parts: a first chamber where gases coming from the inside of the machine enter, and a second chamber that is the real storage tank. A small pipe connected to the solution pump discharge sends a small quantity of solution in the first chamber. The discharge of this liquid is pinched to create a jet effect. Due to this jet effect the area surrounding the pipe connection has a negative pressure. Since this chamber is connected to the main shell of the machine, gases are sucked from the machine inside and sent to the purge device. Once the gases are inside, they are taken to the bottom of the chamber by the solution spray and they are then released in the storage tank. Here they are kept until the purge pump is not activated.
- ❖ The purge pump is provided as a standard feature on all machines. The storage tank has to be evacuated before it gets completely full.

SOLUTION AND REFRIGERANT PUMPS

- ❖ All the machines are provided with Japanese manufactured canned pumps, Teikoku made, self lubricating, factory mounted and wired. Teikoku is a world leader in the manufacturing of this type of pumps and it is well known all over the world for extremely high quality standards.
- ❖ Starting with model 5G 2A C, all the pumps are provided with TRG, a patented bearing monitoring system for monitoring the consumption of the bearings. By simply connecting to a couple of free contacts in the terminal strip of the control panel it is possible to have an indication on the bearing status, without opening the canned motor pumps. The canned motor pumps are provided with over-current and high temperature protection safeties to prevent the motors from burnout.
- ❖ These pumps are of a bolted construction (starting from model 5G 2A C), so that if required bearing and filters can be cleaned. In case of hermetically sealed pumps replacement of entire pump is the only solution. There is great difference in leak rates

caused by moving seal joint and fix seal joint. Canning avoids moving seal joint as pump has no shaft seal. Back cover plate fitted for dismantling the pump does not come in contact with any moving parts. Such fixed sealing allows leak rate to be maintained within international standards without comprising the maintainability.

- ❖ The pumps are also provided with isolating valves (excluded model 5G 1A C) at their suction and discharge ends to ease the removal of the pumps during maintenance without breaking the vacuum inside the chiller.

CROSSOVER PIPING

- ❖ All the various sections of the machines are interconnected by suitably sized seamless carbon steel piping. All the piping is of welded construction complete with necessary valves and fittings. The absorber to the condenser crossover piping suitably welded is a standard feature of all the machines.

AUTOMATIC DECRYSTALLISATION SYSTEM

- ❖ The machines are provided with an auto-decrystallisation line, protecting themselves from crystallisation during operation. If crystallisation occurs, it starts inside the concentrated solution at the outlet of the heat exchanger, where the concentration is higher and the temperature is lower. Here the crystallisation would cause a partial blockage of this line that would reduce the outflow of the concentrated solution from the generator. For the automatic decrystallisation a U-tube is provided connecting the generator to the absorber, bypassing the heat exchanger. The accumulation of the concentrated solution in the generator causes the solution level to rise. The overflow of the hot concentrated solution from the generator to the absorber warms up the weak solution. This heated weak solution warms up the crystallised solution on the opposite side of the heat exchanger. Thus the crystals melt enabling the normal flow of LiBr solution through the heat exchanger.

ANTICRYSTALLISATION SYSTEM

- ❖ The machines are also provided with an advanced state of the art active concentration control. By means of a series of different sensors, machine's PLC is able to calculate in every moment the maximum solution concentration inside the machine and compare it with the calculated critical value. If actual concentration is too close to the critical value, concentration control system takes the control of the machine, modulating the control valve to take the concentration level back to safe values. Also an autoblowdown valve is

provided as extra safety: when concentration exceeds a set value, valve opens letting refrigerant flowing into absorber thus reducing solution concentration. A decrystallisation system starts acting when crystallisation has already taken place: the Thermax concentration control instead ensure that machine will always work far away from crystallisation area.

GRAVITY FEED TRAYS

- ❖ The machines are provided with a gravity feed tray system, composed of a series of steel drilled trays for the distribution of the refrigerant and the solution over the respective tube bundles. These gravity feed trays are located just above the top of the respective tube bundle and have perforations perfectly aligned with and running along the entire length of the tube bundle. This gravity feed arrangement enhances high degree reliability in operation and longer machine life by eliminating the erosion of the spraying nozzles and the disruption of flow due to the clogging of the nozzles with impurities. Furthermore this system doesn't require a supplementary solution pump to provide extra pressure to win the pressure drop generated by the nozzles of a spray system.

CAPACITY CONTROL

- ❖ Stepless and continuous capacity control from 10% to 100%, based on the chilled water outlet temperature. The chilled water flow to the chiller is kept constant. So the cooling capacity is proportional to the temperature difference between the inlet and the outlet water temperature. Load fluctuations reflect in increasing or decreasing of the inlet chilled water temperature, and consequently of the outlet one. A sensor on the chilled water outlet senses the temperature change and gives a control signal. The signal is electrically amplified by a PLC and converted into a 4-20mA control signal by a PID algorithm, then it goes to the actuator of the control valve. As the load starts increasing, the control valve starts opening and closes as the load decreases.

CORROSION INHIBITOR

- ❖ A proper corrosion inhibitor is added to the solution to minimize the possibility of any corrosion taking place in the machine. A large number of first generation absorption machines used lithium nitrate or chromate as the corrosion inhibitor. But the nitrate desiccates at high temperatures, becomes unstable and can lead to the generation of ammonia, while the chromate is toxic. These machines use the lithium molybdate as

corrosion inhibitor, since it has excellent corrosion inhibitor properties, it doesn't desiccate at high temperatures and it is not toxic.

REFRIGERANT BLOWDOWN VALVE

- ❖ Refrigerant blow down valves placed between evaporator and absorber, to allow the by pass of refrigerant from one to the other. The refrigerant vapors generated in the generator are always contaminated with small solution drops that are continuously stopped by the eliminators. In spite of them a small quantity of solution always remains with the refrigerant and goes to the condenser. As the quantity of solution in the refrigerant increases, the machine will slowly but continuously reduce its capacity. In fact during the refrigerant evaporation in the evaporator, the LiBr solution is not effective in the heat transfer process and so the capacity will be reduced. For this reason the refrigerant blow down valve has to be operated on a periodic basis.

REFRIGERANT LEVEL CONTROL

- ❖ Starting with model 5G 2A C all units are provided with reliable level electrodes to control the refrigerant level in the evaporator. These electrodes ensure that the correct signal is given to the refrigerant pump to avoid it entering a cavitation zone and they are more precise and reliable than the traditional floating system. In smaller models refrigerant pump is controlled by generator temperature.

RUPTURE DISK

- ❖ All the machines are provided with a rupture disk as a standard feature. It is mounted on the shell side of the generator. When the pressure inside the generator raises above the critical value, the disk bursts open releasing the pressure inside, avoiding any major damage to the machine.

FACTORY TESTS

SOAP TEST

- ❖ Nitrogen is charged into the machine at a pressure up to 130 to 140 kPa. After charging is over, test is carried out with soap solution. A soap solution is spread evenly over the joints and on the expanded tube ends. If there is any leakage the nitrogen will try to leak

from the joint, and because of the soap solution, bubbles will be formed. These leak points are marked and repaired/rewelded.

DECAY TEST

- ❖ After repairing the leaks found out during nitrogen testing, the machine is again charged with nitrogen up to 130 kPa pressure. The machine is kept at this pressure for 24 hours. If any leakage occurs nitrogen will escape to the atmosphere and the pressure will start reducing thus showing the leakage. If a leakage is found in the decay test, the joints are thoroughly rechecked as in the previous step and they are repaired.

HELIUM SPRAY TEST

- ❖ The helium molecule is the next smallest molecule after the hydrogen molecule in the periodic table and it will leak through very minute holes. The absorption machine is fully evacuated (vacuumed). After vacuuming, the machine is connected to a special helium leak detector. The helium is spread on all the joints. As the machine is under vacuum, a leakage in the joints will result in helium entering into the machine which will be shown on the screen of the helium leak detector. If the cumulative leak rate is more than 1×10^{-7} standard cc/sec. then the joints are marked and repaired.

HELIUM SHROUD TEST

- ❖ The machine is fully covered by a polythene sheet and the helium is passed under the polythene cover. The leak rate is observed in the leak detector machine for 30 minutes. In this test, the leak rate allowable is up to 1×10^{-7} standard cc/s.

CONTROLS AND SAFETIES

GENERAL FEATURES

The units come with a Siemens S7/1200 Programmable Logic Controller (PLC), provided with the most advanced technological features to grant safe and economic operation, in order to make these products highly efficient, reliable and user friendly.

The control equipment is enclosed in a rugged dust proof sheet metal casing mounted on the chiller with IP42 protection. The control panel consists of the following:

- ❖ Main circuit breaker for safety against electrical hazards.
- ❖ MPCB for solution, refrigerant and vacuum pumps.

- ❖ Terminal blocks for control and power connections.
- ❖ Microprocessor based PLC Siemens S7/1200 for operational logic and sequence, safety and capacity control through PID algorithm. PLC uses a powerful CPU Siemens 1215C.
- ❖ 7" touchscreen graphic display Siemens TP700.
- ❖ Modbus RTU connectivity as a standard feature.
- ❖ Ultra isolation control transformer with MCB protection for control circuit.
- ❖ Level electrodes for refrigerant level monitoring in the evaporator (starting from model 5G 2A C).
- ❖ Individual contactors and thermal overcurrent relays for all pumps motors.
- ❖ Interlocks for chilled and cooling water pumps.
- ❖ Temperature sensors and display for the following:
 - Chilled water inlet and outlet.
 - Cooling water inlet and outlet.
 - Hot water inlet and outlet.
 - Concentrated solution at generator outlet.
 - Concentrated solution sprayed in absorber.
 - Dilute solution.
 - Condensed refrigerant.
- ❖ Antifreeze protection safeties (PLC inbuilt antifreeze alarm, antifreeze thermostat, low temperature cut-out for the refrigerant pump (L-cut), flow switch (starting from model 5G 2A C) and a D.P. switch for chilled water).
- ❖ Crystallisation prevention (low and high cooling water inlet temperature cut-out, high temperature control for generator, regulating valve PLC control based on generator temperature).
- ❖ Alarm state annunciation through an audio signal and appropriate messages display on the operator interface terminal.
- ❖ Last 24 hour logging facility at a sampling time of one hour intervals and last six alarms logging facility are provided for better understanding of the behavior of the unit during alarm conditions and for easy diagnosis.

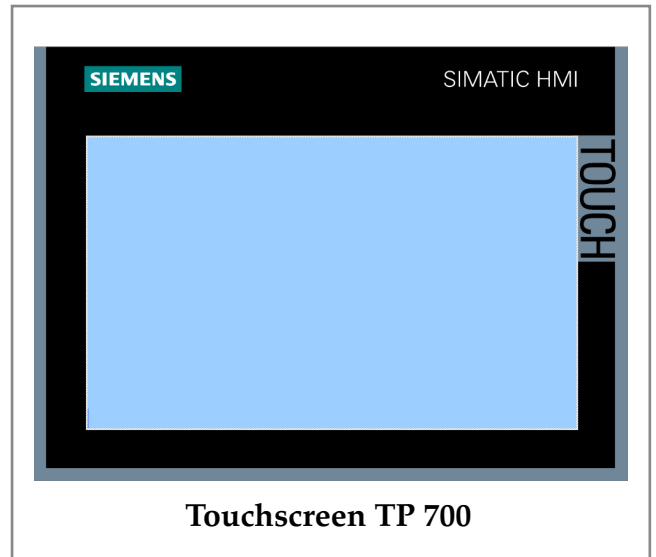

-
- ❖ Possibility to modify data logging frequency time and make it faster after an alarm is activated.
 - ❖ Machine status indication on the display.

CONTROL AND SELF DIAGNOSTIC FUNCTIONS

The control panel has the following functions:

- ❖ Remote and local access for sequential operation of the chiller.
- ❖ Hot water consumption control by a tight control of the chilled water outlet temperature accomplished by a microprocessor PID algorithm. This algorithm allows the machine to keep the chilled water temperature fluctuations within the set values by continuously modulating the control valve and allowing to partialize the load from 10 to 100% of the nominal value. Keypad variation of the set point is possible to get a minimum of 3,5°C outlet chilled water temperature (limitations applied, check with Thermax representative for more details).
- ❖ Status indication with audio visual alarm for malfunction.
- ❖ Thermal shock protection: in order to avoid dangerous thermal shock of the tubes material, at machine starting the PLC control system generates a 4-20 mA control signal that gradually opens the control valve without taking care of outlet chilled water temperature. This signal starts only if the outlet chilled water temperature is more than the set point one. After 7 minutes, the control is switched over to chilled water temperature modulation automatically.
- ❖ Nuisance trip prevention anti chattering timer delays tripping of chilled water flow switch and differential pressure switch by a few seconds, in order to avoid dangerous starting and stopping of the machine due to fluctuations in the chilled water flow.

SAFETY FUNCTIONS

The safety functions protect the machine from abnormal working conditions. The different safety functions are as follows:

- ❖ Thermal shock protection
- ❖ Antifreeze protection
- ❖ Crystallisation protection.
- ❖ Cavitation protection of refrigerant pump
- ❖ Motors protection.

Thermal shock protection

In order to avoid dangerous thermal shock to the tube material, at machine starting the control valve is gradually and slowly opened for the first 7 minutes, when the generator temperature is very low irrespective of the outlet chilled water temperature. After 7 minutes, the control is switched over to chilled water temperature modulation automatically.

Antifreeze protection

In order to prevent the chilled water freezing in the evaporator tubes, the following functions stop the machine in abnormal conditions leading to the formation of ice:

L-cut. If the chilled water outlet temperature drops below the L-cut set point, the refrigerant pump is switched off. This prevents a further temperature drop of the chilled water below the set value.

Internal antifreeze thermostat. If the chilled water outlet temperature drops below the internal antifreeze set point, the machine trips.

Antifreeze thermostat. If the chilled water outlet temperature drops below the antifreeze thermostat set point the machine trips.

Chilled water pump interlock. The chilled water flow is essential for the machine operation. A potential free contact is to be wired from the chilled water pump motor starter or from one flow switch (in customer scope) to the machine panel to sense the chilled water pump on/off/trip status. The machine starts only if the chilled water pump is on. In case the chilled water pump trips and in order to avoid the freezing of the static chilled water in the tubes inside the machine, it is mandatory to stop the cooling water pump. For this reason it is mandatory that the PLC has control over the chilled and cooling water pumps. Four potential free contacts are provided in the panel to control the pumps switching on and off.

Chilled water differential pressure switch. If the chilled water flow drops below 50% of the rated value, machine trips.

Chilled water flow switch. If the chilled water flow drops below 50% of the rated value, machine trips.

Crystallisation prevention

If the concentrated solution returning to the absorber from the generator is excessively cooled, it crystallises in the heat exchanger and the operation of the machine is affected. Crystallisation occurs either when the concentration of the solution (for a particular temperature) goes too high or its temperature (for a particular concentration) goes too low. The following safety functions prevent the machine from crystallising:

Control valve. When the generator temperature is more than the critical temperature set in the PLC, the control valve immediately closes. This is to avoid a further increase in concentration.

Generator high temperature safety. If the generator temperature exceeds the generator high temperature set point, the machine trips.

Cooling water low temperature safety. If the cooling water inlet temperature drops below the cooling water low temperature set point, the machine trips.

Cooling water high temperature safety. If the cooling water inlet temperature goes above the cooling water high temperature set point, the machine trips.

Active concentration control. By means of a series of different sensors, machine's PLC is able to calculate in every moment the maximum solution concentration inside the machine and compare it with the calculated critical value. If actual concentration is too close to the critical value, concentration control system takes the control of the machine, modulating the control valve to take the concentration level back to safe values. Furthermore an autoblowdown valve is provided between evaporator and absorber: when concentration goes beyond a critical value, valve is opened and refrigerant will flow to absorber, lowering down solution concentration.

Cavitation protection of refrigerant pump (starting from model 5G 2A C)

If the refrigerant level in the evaporator pan falls excessively, the pressure in the refrigerant pump suction drops below the saturation pressure of the refrigerant and the refrigerant pump starts to cavitate. To ensure the minimum acceptable suction pressure the level of the refrigerant is not allowed to fall below a certain level. This is done by means of three level electrodes RE1, RE2, RE3 and a level relay, 33RL.

The three electrodes are mounted in the refrigerant level box assembly on the lower shell (evaporator side). RE1 electrode is the smallest in length and RE3 is the longest. The level is maintained between RE1 and RE2. RE3 acts as a reference electrode. When the level reaches RE1, the pump starts and when goes below RE2, the pump stops and restarts only when the level reaches RE1 again. When the level goes below RE2, a delay of 10 seconds is provided before the pump is switched off.

Motors protection

Solution, refrigerant and vacuum pumps overload relay.

INFORMATION DISPLAY

Operating information is in English language with SI units. Standard information shown are:

- ❖ Chilled water inlet and outlet temperatures.
- ❖ Cooling water inlet and outlet temperatures.
- ❖ Hot water inlet and outlet temperatures.
- ❖ Concentrated solution temperature at generator outlet.
- ❖ Concentrated solution temperature sprayed into absorber.
- ❖ Dilute solution temperature.
- ❖ Condensed refrigerant temperature.
- ❖ Percentage opening of control valve.
- ❖ Machine operating hours.
- ❖ Purge pump operating hours.
- ❖ Date of last purge cycle.

FUNCTIONAL COMMANDS

- ❖ Chiller remote/local mode.
- ❖ Chiller start/stop in local access.
- ❖ Refrigerant pump auto/manual mode.
- ❖ Refrigerant pump start/stop in manual.
- ❖ Vacuum pump start/stop.
- ❖ Control valve auto/manual mode.
- ❖ Control valve open/close in manual.
- ❖ Alarm acknowledge.
- ❖ Alarm reset.
- ❖ Maximum opening of control valve setpoint.
- ❖ Chilled water shut off valve open/close (if applicable).
- ❖ Cooling water shut off valve open/close (if applicable).
- ❖ Hot water shut off valve open/close (if applicable).

STATUS DISPLAY

- ❖ Chiller on/off/In dilution cycle.
- ❖ Chiller local/remote mode.
- ❖ Chilled water flow switch ON/OFF (starting from model 5G 2A C).
- ❖ Chilled water differential pressure switch ON/OFF.

-
- ❖ Chilled water interlock ON/OFF.
 - ❖ Temperature sensors healthy / trip.
 - ❖ Chilled water antifreeze thermostat healthy / trip.
 - ❖ Cooling water pump on/off.
 - ❖ Hot water pump on/off.
 - ❖ Cooling tower fans ON/OFF (if wired).
 - ❖ Solution pump on/off/trip.
 - ❖ Refrigerant pump auto/manual mode.
 - ❖ Refrigerant pump on/off/trip.
 - ❖ Vacuum pump on/off/trip.
 - ❖ L-cut function healthy / trip.
 - ❖ Control valve status.
 - ❖ Refrigerant level indication in the evaporator (starting from model 5G 2A C).

POTENTIAL FREE CONTACTS FOR REMOTE WORKING

- ❖ Remote machine start/stop.
- ❖ Remote machine status indication (On/Off).
- ❖ Remote machine trip indication.
- ❖ Chilled water pump start/stop.
- ❖ Cooling water start/stop signal.
- ❖ Hot water pump start/stop signal.

4-20 mA OUTLET SIGNALS

- ❖ Hot water control valve signal.
- ❖ Cooling tower control signal (if applicable).
- ❖ Control signal to AC drive of cooling water pump (if applicable).
- ❖ Control signal to AC drive of hot water pump (if applicable).
- ❖ Control signal to mixing valve in chilled water circuit (if applicable).

4-20 mA INLET SIGNALS

- ❖ Chilled water temperature remote setpoint.
- ❖ Maximum opening of hot water control valve remote setpoint.
- ❖ Hot water control valve feedback (if applicable).
- ❖ Cooling water control valve feedback (if applicable).

ACCESSORIES

- ❖ Special tubes material for tubes of evaporator, absorber and condenser, based on the water quality circulating in the tubes. Materials available are:
 - Cupro-Nickel
 - Stainless steel
 - Titanium
- ❖ On request the machine can be provided with a palladium cell to automatically evacuate the hydrogen from the machine. The inside walls of this cell are made with palladium. The main device of this material is that at high temperatures it becomes porous to hydrogen. When the electric heater is switched on, palladium tubes get heated and hydrogen (most of the non condensable gases inside the machine are hydrogen) is evacuated from the cell directly into the atmosphere. In this way a vacuum inside the machine is automatically maintained using a completely static system.
- ❖ Automatic purge system: PLC will sense the pressure in purge tank and it will operate vacuum pump and pneumatic/electric valves to purge the system in a fully automatic mode.
- ❖ Insulation of hot and cold surfaces directly done at factory.
- ❖ TRG reading directly from control panel through analogic device rather than through free potential contact is control panel (starting from model 5G 2A C).
- ❖ Inverter on solution pump.
- ❖ Modbus TCP/IP connection.
- ❖ Profibus connection.
- ❖ Ethernet connection.

TECHNICAL DATA - 1

MODEL		5G 1A C	5G 1B C	5G 1C C	5G 2A C	5G 2B C	5G 2C C	
Cooling capacity at conditions (A)		kW	67	132	200	262	450	
Cooling capacity at conditions (B)		kW	61	122	182	238	395	
Cooling capacity at conditions (C)		kW	48	83	123	165	272	
CHILLED WATER								
Inlet/outlet temperature		°C	12/7					
A	Flow	m ³ /h	11,5	22,7	34,4	45	61,9	77,4
	Friction loss	kPa	24,3	37,2	40,9	62,6	29,4	27,6
	Number of passes		6	4	4	4	3	2
B	Flow	m ³ /h	10,5	21	31,3	40,9	55,7	67,9
	Friction loss	kPa	20,2	31,8	33,9	51,8	23,8	21,3
	Number of passes		6	4	4	4	3	2
C	Flow	m ³ /h	8,3	14,3	21,1	28,4	37,8	46,8
	Friction loss	kPa	28,3	14,8	15,6	25,1	24,3	32,2
	Number of passes		8	4	4	4	4	3
Maximum working pressure		kPa	785					
Nozzle dimension		DN	50	80	80	100	100	125
Heat exchanger hold up volume		l	30	70	90	125	150	180
COOLING WATER								
A	Inlet/outlet temperature	°C	29-34,1	29-34,7	29-34,5	29-34,8	29-34	29-34
	Flow	m ³ /h	28	48,5	75,9	93,6	150	183
	Friction loss	kPa	50,6	75,4	85,3	87,8	81,1	52,9
	Number of passes		6/2	4/2	4/2	4/2	3/2	2/1
B	Inlet/outlet temperature	°C	29-34	29-34,3	29-34	29-34,3	29-34	29-34
	Flow	m ³ /h	26	48,5	75,9	93,6	135	160
	Friction loss	kPa	44	75,4	85,3	87,9	66,8	41,4
	Number of passes		6/2	4/2	4/2	4/2	3/2	2/1
C	Inlet/outlet temperature	°C	29-34,1	29-34	29-34	29-34	29-34	29-34
	Flow	m ³ /h	20	35	52	70	93	112
	Friction loss	kPa	26,8	40,5	41,5	51,7	33,7	47,1
	Number of passes		6/2	4/2	4/2	4/2	3/2	2/2
Maximum working pressure		kPa	785					
Nozzle dimension		DN	80	100	100	125	125	150
Heat exchanger hold up volume		l	100	210	250	330	370	445
HOT WATER								
A	Inlet/outlet temperature	°C	95-82					
	Flow	m ³ /h	6,6	12,9	19,3	25,2	34,4	41,1
	Friction loss	kPa	2,3	7,4	7,9	11,2	11,7	31,7
	Number of passes		4					
B	Temperatura in/out	°C	90-80					
	Inlet/outlet temperature	m ³ /h	7,9	15,4	22,8	29,7	40,2	47
	Flow	kPa	3,2	10,3	10,8	15,4	15,8	40,9
	Friction loss		4					
C	Inlet/outlet temperature	°C	90-75	90-70				
	Flow	m ³ /h	4,2	5,4	7,9	10,6	14	16,6
	Friction loss	kPa	1	1,5	1,6	2,3	2,3	6,1
	Number of passes		4					
Maximum working pressure		kPa	785					
Nozzle dimension		DN	50	80	80	100	100	125
Heat exchanger hold up volume		l	30	30	60	125	160	190
ELECTRICAL DATA								
Power supply			415V +/- 10%, 50 Hz +/- 3%, 3ph + N					
Soluition pump		kW (A)	1,1 (3,4)			1,5 (5,0)		
Refrigerant pump		kW (A)	0,1 (0,6)			0,3 (1,4)		
Vacuum pump		kW (A)	0,75 (1,8)					
Total electric consumption		kVA	5,1			6,9		

(A)= Hot water 95-82°C. (B)= Hot water 90-80°C (C)= Hot water 90-70°C

Fouling factors 0,018 m² K/kW in chilled and hot water circuits, 0,044 m² K/kW in cooling water circuit.

For working conditions different from above, please contact authorised Thermax office to request a customised selection.

TECHNICAL DATA - 2

MODEL			5G 2D C	5G 2E C	5G 3A C	5G 3B C
Cooling capacity at conditions (A)		kW	532	630	764	872
Cooling capacity at conditions (B)		kW	470	568	692	792
Cooling capacity at conditions (C)		kW	336	400	486	560
CHILLED WATER						
Inlet/outlet temperature		°C	12/7			
A	Flow	m ³ /h	91,5	108,3	131,3	149,9
	Friction loss	kPa	27,3	44,4	44,8	43,7
	Number of passes		2			
B	Flow	m ³ /h	80,8	97,6	119	136,2
	Friction loss	kPa	21,4	36,2	36,8	36,1
	Number of passes		2			
C	Flow	m ³ /h	57,8	68,8	83,6	96,3
	Friction loss	kPa	33,9	18,1	18,3	18,2
	Number of passes		3	2	2	2
Maximum working pressure		kPa	785			
Nozzle dimension		DN	125	125	150	150
Heat exchanger hold up volume		l	205	235	305	340
COOLING WATER						
A	Inlet/outlet temperature	°C	29-34	29-34,3	29-34,4	29-34,5
	Flow	m ³ /h	214	239	285	321
	Friction loss	kPa	54,9	75,5	68,7	70,1
	Number of passes		2/1	2/1	2/1	2/1
B	Inlet/outlet temperature	°C	29-34	29-34	29-34	29-34
	Flow	m ³ /h	190	230	282	321
	Friction loss	kPa	44,2	70,4	67,4	70,1
	Number of passes		2/1	2/1	2/1	2/1
C	Inlet/outlet temperature	°C	29-34	29-34	29-34	29-34
	Flow	m ³ /h	137	165	200	232
	Friction loss	kPa	49,6	38,4	36,2	38,9
	Number of passes		2/2	2/1	2/1	2/1
Maximum working pressure		kPa	785			
Nozzle dimension		DN	150	150	200	200
Heat exchanger hold up volume		l	490	545	720	775
HOT WATER						
A	Inlet/outlet temperature	°C	95-82			
	Flow	m ³ /h	48,6	57,7	70	79,9
	Friction loss	kPa	32	51,7	48,7	48
	Number of passes		4			
B	Temperatura in/out	°C	90-80			
	Inlet/outlet temperature	m ³ /h	56	67,6	82,3	94,2
	Flow	kPa	41,8	25,4	23,8	23,8
	Friction loss		4			
C	Inlet/outlet temperature	°C	90-70			
	Flow	m ³ /h	20,5	24,4	29,7	34,2
	Friction loss	kPa	6,7	10,8	10,2	10,2
	Number of passes		4			
Maximum working pressure		kPa	785			
Nozzle dimension		DN	125	125	150	150
Heat exchanger hold up volume		l	220	255	315	360
ELECTRICAL DATA						
Power supply			415V +/- 10%, 50 Hz +/- 3%, 3ph + N			
Solution pump		kW (A)	1,5 (5,0)			
Refrigerant pump		kW (A)	0,3 (1,4)			
Vacuum pump		kW (A)	0,75 (1,8)			
Total electric consumption		kVA	6,9			

(A) = Hot water 95-82°C. (B) = Hot water 90-80°C (C) = Hot water 90-70°C

Fouling factors 0,018 m² K/kW in chilled and hot water circuits, 0,044 m² K/kW in cooling water circuit..

For working conditions different from above, please contact authorized Thermax office to request a customized selection.

DIMENSIONS AND WEIGHTS

DIMENSIONS (in mm)

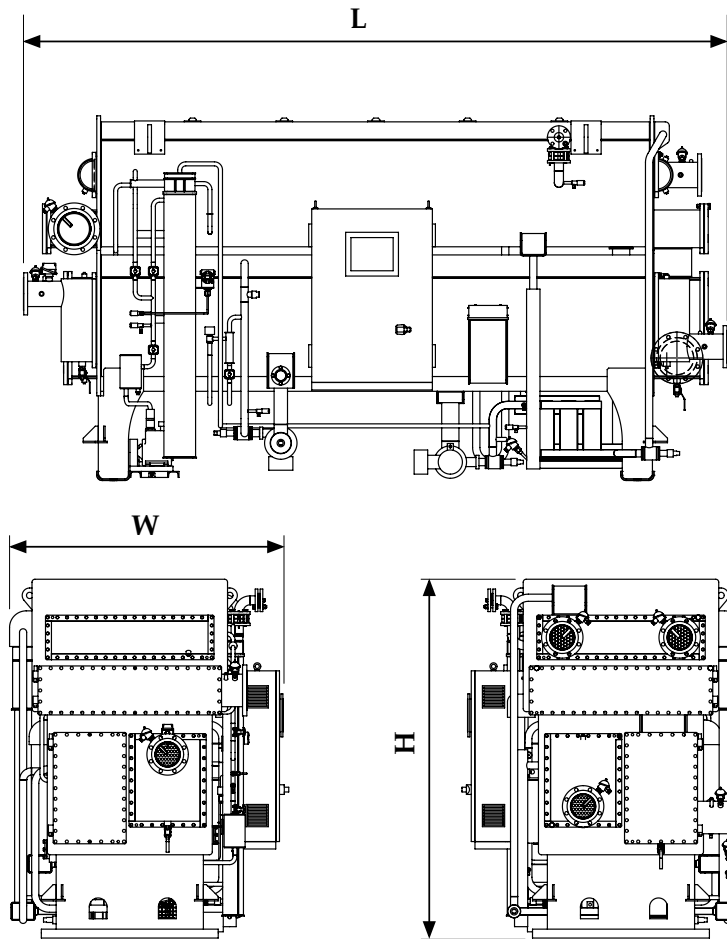

Model	5G 1A C	5G 1B C	5G 1C C	5G 2A C	5G 2B C	5G 2C C	5G 2D C	5G 2E C	5G 3A C	5G 3B C
Length (L)	1.670	2.535	2.535	2.840	2.840	3.755	3.755	4.360	4.415	4.415
Width (W)	1.400	1.635	1.635	1.575	1.575	1.655	1.655	1.655	1.870	1.870
Height (H)	1.820	2.200	2.200	2.310	2.310	2.310	2.310	2.310	2.420	2.420

SERVICE CLEARANCE (in mm)

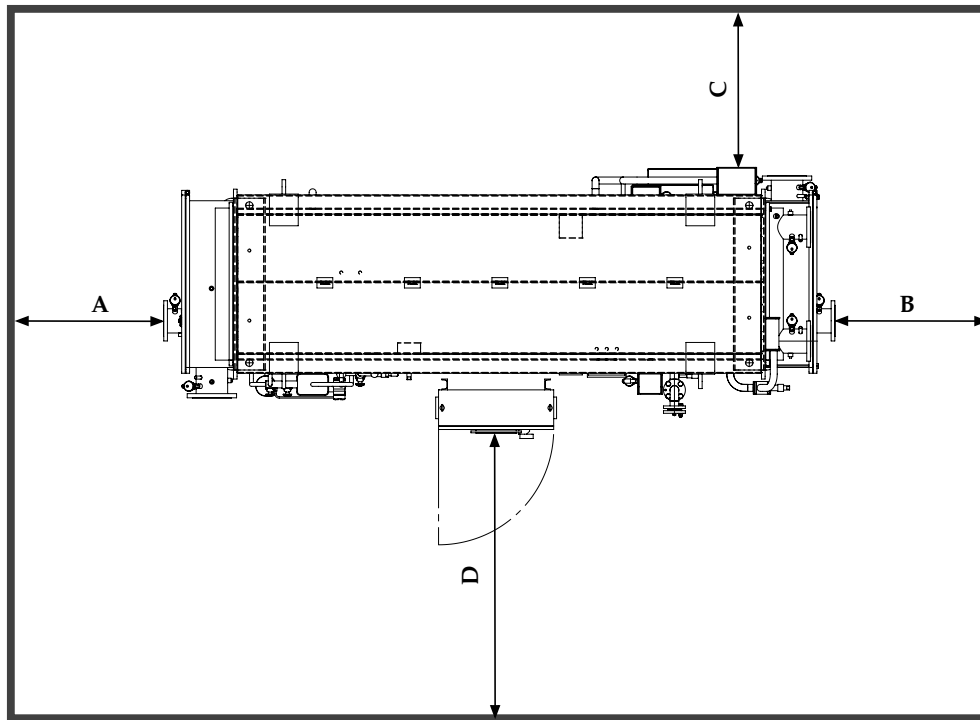

Model	5G 1A C	5G 1B C	5G 1C C	5G 2A C	5G 2B C	5G 2C C	5G 2D C	5G 2E C	5G 3A C	5G 3B C
A (**)	1.250	2.110	2.110	2.350	2.350	3.390	3.390	4.000	4.060	4.060
B	500	500	500	500	500	500	500	500	500	500
C	500	500	500	500	500	500	500	500	500	500
D	1.200	1.200	1.200	1.200	1.200	1.200	1.200	1.200	1.200	1.200
TOP	200	200	200	200	200	200	200	200	200	200

(**): "A" is the clearance space for tubes maintenance and removal. It can be left on either side of the chiller, depending on the convenience of site.

WEIGHTS (in kg)

Modello	5G 1A C	5G 1B C	5G 1C C	5G 2A C	5G 2B C	5G 2C C	5G 2D C	5G 2E C	5G 3A C	5G 3B C
Dry weight	1.800	3.200	3.400	3.900	4.000	4.900	5.100	5.700	6.600	6.800
Shipping weight	2.000	3.600	3.800	4.400	4.600	5.700	5.900	6.600	7.700	8.000
Operating weight	2.200	3.900	4.200	5.000	5.200	6.500	6.800	7.700	9.100	9.500
Flooded weight	2.800	5.400	5.600	7.000	7.200	9.700	9.900	11.400	13.900	14.200

- Dry weight: weight of the machine without any liquid inside.
- Shipping weight: weight of the machine + weight of the working liquids (LiBr solution and refrigerant)
- Operating weight: weight of the machine + weight of the working liquids + weight of the water inside the heat exchangers
- Flooded weight: maximum weight the machine can reach when all internal volume is filled with water.

FOUNDATIONS

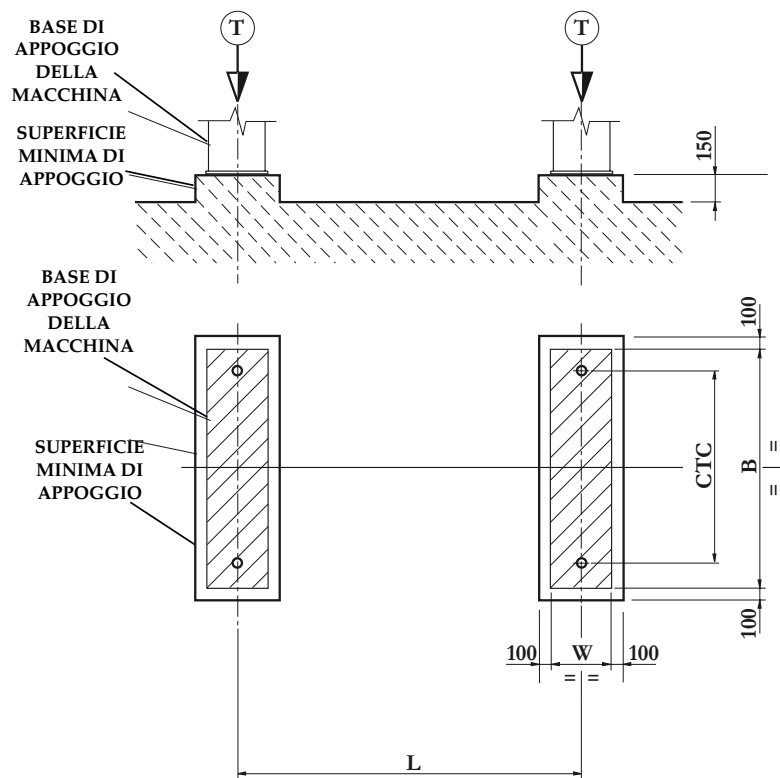

Model	5G 1A C	5G 1B C	5G 1C C	5G 2A C	5G 2B C	5G 2C C	5G 2D C	5G 2E C	5G 3A C	5G 3B C
L (mm)	852	1.582	1.582	1.846	1.846	2.866	2.866	3.474	3.474	3.474
W (mm)	170	220	220	220	220	220	220	220	324	324
B (mm)	792	872	872	1.032	1.032	1.032	1.032	1.032	1.192	1.192
CTC (mm)	692	772	772	932	932	932	932	932	1.092	1.092
T (kg)	1.100	1.950	2.100	2.500	2.600	3.250	3.400	3.850	4.550	4.750
T _{max} (kg)	1.400	2.700	2.800	3.500	3.600	4.850	4.950	5.700	6.950	7.100

T: machine's operating weight on each foundation

T_{max}: maximum machine's flooded weight on each foundation

NOTE: in case of PED approval or non standard pressures in water circuits, weights may change.

INSULATION

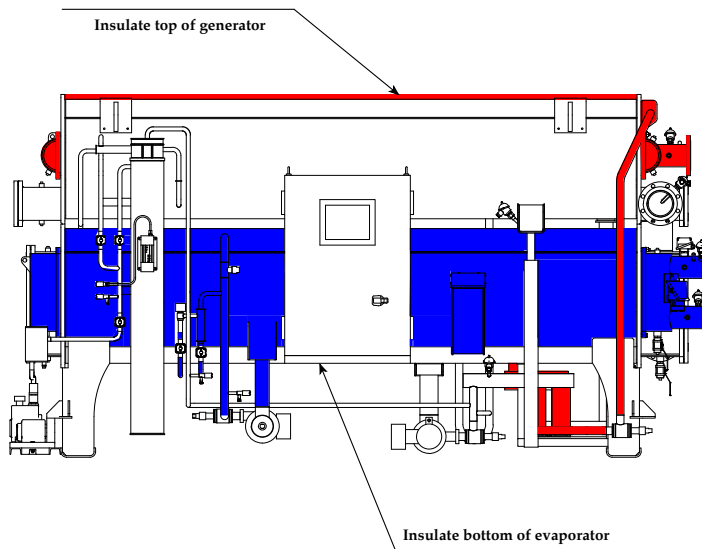
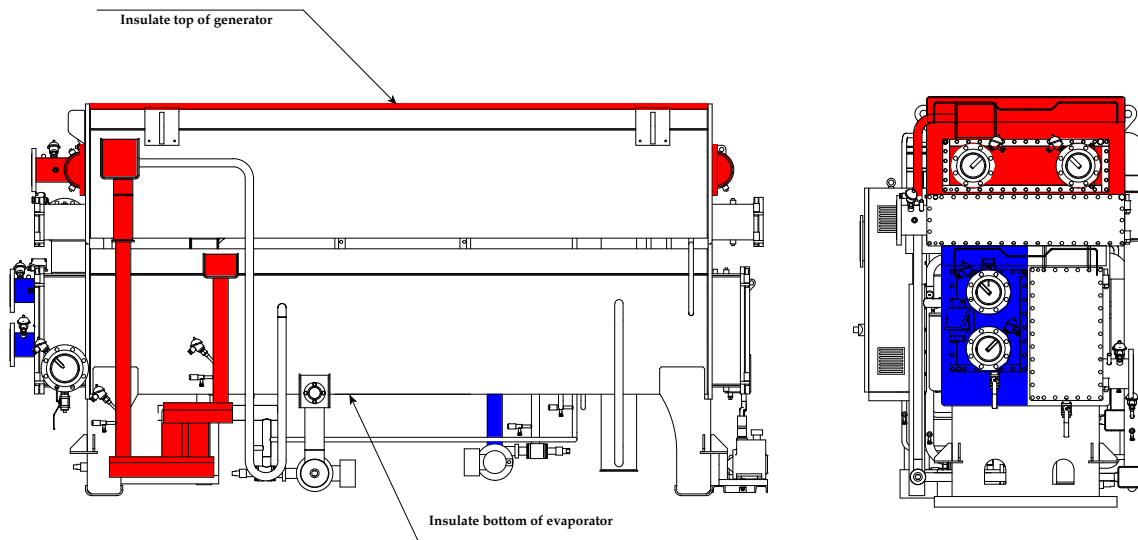

	19 mm thick EPDM foam insulation	120°C max
	25 mm thick elastomeric foam insulation	0°C min

NOTES

- ➔ Cold insulation is provided as a standard feature on all machines.
- ➔ Do not cover refrigerant pump motor with insulation.
- ➔ Do not cover sight glasses with insulation.
- ➔ Lower shell top side insulation to be done first before upper shell bottom side insulation.

→ Evaporator headers to be detachable.

SURFACES TO BE INSULATED (in m²)

Model	5G 1A C	5G 1B C	5G 1C C	5G 2A C	5G 2B C	5G 2C C	5G 2D C	5G 2E C	5G 3A C	5G 3B C
	4	6	6	7	7	9	9	9,5	12	12
	3	4,5	4,5	5,5	5,5	7,5	7,5	8,5	9,5	9,5

Model	5G 6K C	5G 6L C	5G 7K C	5G 7L C	5G 7M C	5G 8K C	5G 8L C	5G 8M C	5G 8N C
	27,91	27,91	33,93	33,93	33,93	38,82	38,82	43,80	43,80
	18,50	18,50	25,98	25,98	25,98	29,02	29,02	33,46	33,46

PERFORMANCE CURVES

The following curves show the qualitative trend of the cooling capacity when some typical operative conditions are changed.

They provide a first tool to qualitatively estimate the effects of some changes in the working conditions on the cooling capacity.

Anyway, for a more precise evaluation, it is recommended to ask to Thermax authorized offices for one or more machine selections based on the required working parameters.

Indications of below graphs are only indicative.

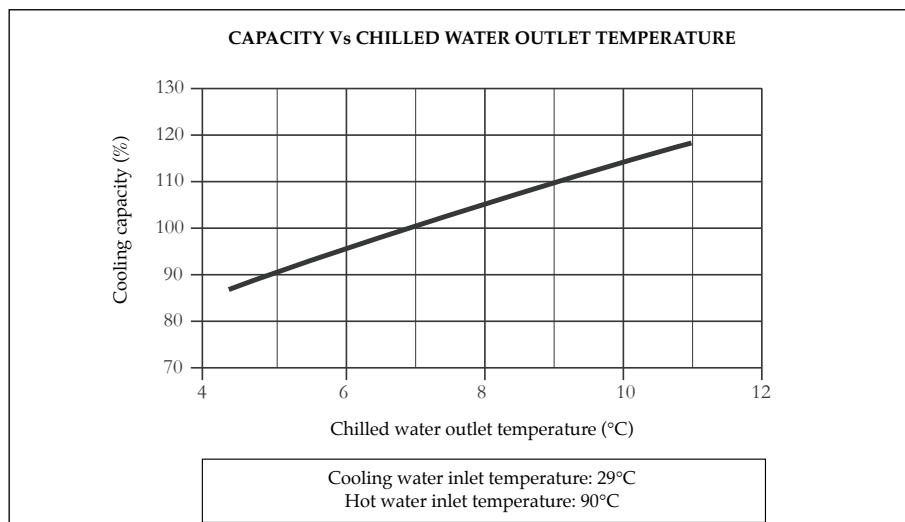

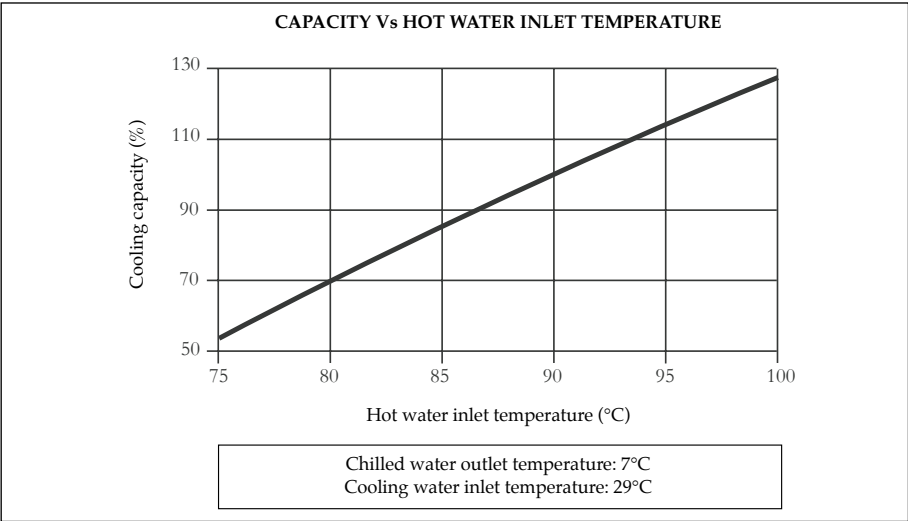
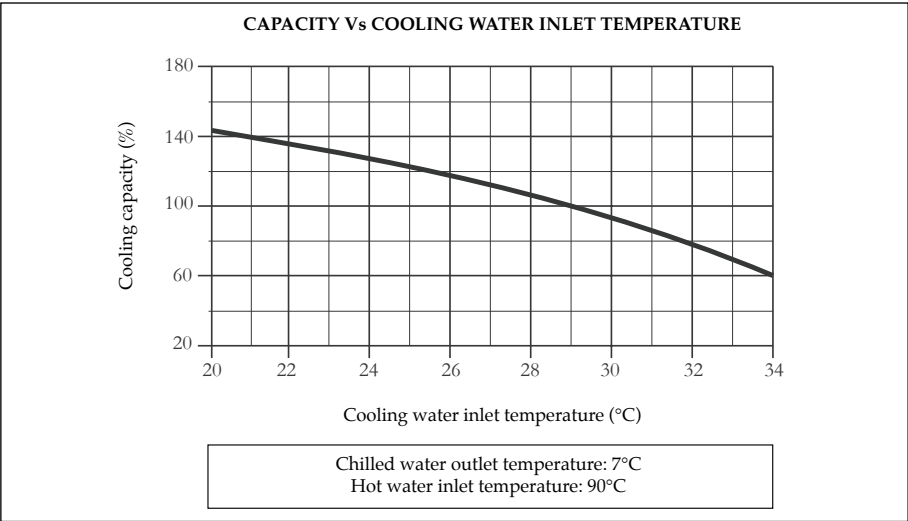
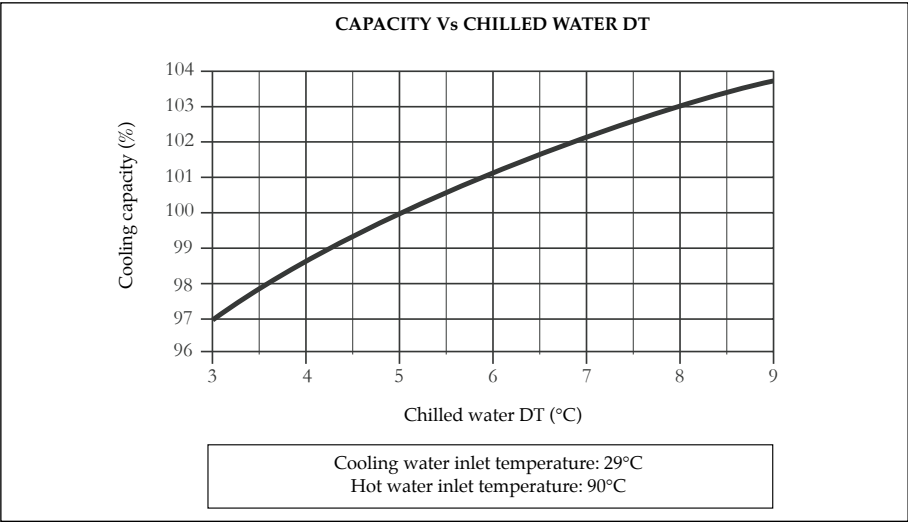

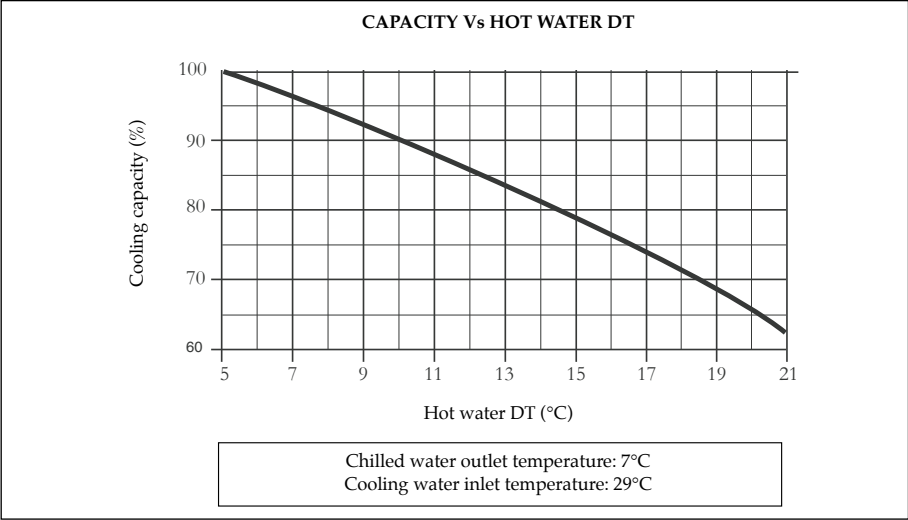

TYPICAL P&I DIAGRAM

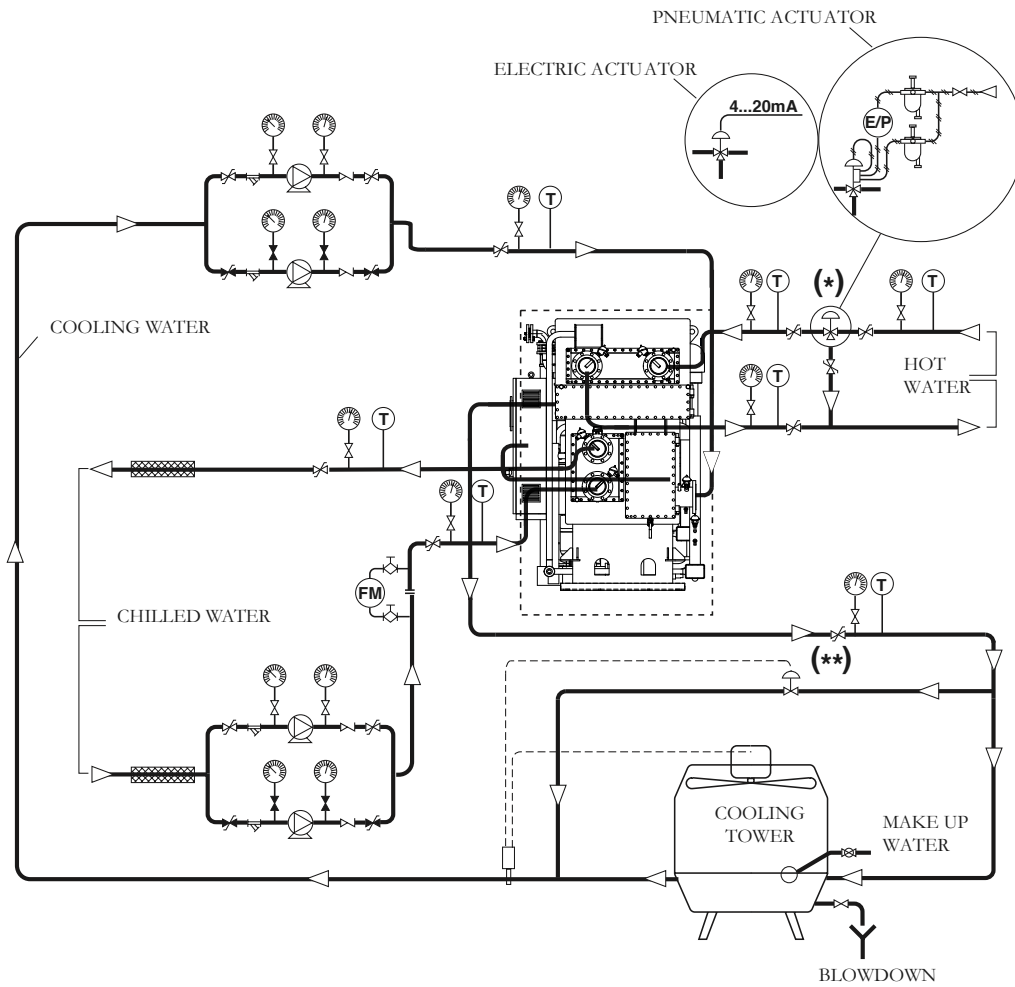

▶ Device closed	☒ Cock	☒ Control valve
◀ Device open	⊙ Manometer	▨ 50mm insulation
☒ Butterfly valve	⊙ Water pump	4...20mA Drive signal
☒ Globe valve	☐ Thermostat	— Pneumatic line
▶ Non return valve	⊙ Thermometer	☒ Air filter regulator
☒ "Y" strainer	⊙ FM Flowmeter	⊙ E/P convertor

(*): the scheme is valid for diverting type hot water control valve. In case of mixing valve, it has to be installed at the outlet of hot water from machine. Refer to installation manual for more detailed information.

(**): cooling water by-pass valve is required only in case of low cooling water temperatures. Refer to installation manual for more details.



THERMAX EUROPE LIMITED, 2 STUDIO COURT, QUEENSWAY, BLETCHLEY
MILTON KEYNES MK2 2DG, UNITED KINGDOM
Telephone: +44 1908 378914 Fax: +44 1908 379487
e-mail: info@thermax-europe.com

Technical data and dimensions are not binding. In view of our constant endeavor to improve the quality of products, we reserve the right to amend any product details and contents of this literature without prior notice.

TECH-5G-SMALL.ENG.REV1-2016

www.thermax-europe.com