



SS

Steam fired
Absorption chillers
Single effect



350 - 7.000 kW

SS SERIES

Steam fired single effect absorption chillers

INTRODUCTION

WORKING PRINCIPLE

Absorption chillers operate on the basis of three well known physical phenomena:

- A) When a liquid evaporates (or boils) it absorbs heat, and when it condenses it gives up heat.
- B) The evaporating temperature of a liquid is a function of the pressure. I.e. as the pressure decreases so does the boiling point.
- C) Some chemicals that have a strong affinity to absorb another.

In a conventional, mechanical vapor compression cycle, the refrigerant evaporates at low temperature producing cooling. It is then compressed mechanically to an elevated pressure, then it is

cooled and condensed. Most of the machines have a compressor powered by an electric motor. In an absorption chiller the evaporator and condenser are essentially the same, but a chemical absorber and a thermal generator replace the compressor, with a small pump to provide pressure change. As a pump requires much less power than a compressor.

The functions described operate in an absorption chiller as follows:

1. Refrigerant water evaporates in a deep vacuum "6 mmHg absolute" to a lower sealed shell at a temperature of 3,7°C.

The chilled water circuit tube bundle is thereby cooled. The left hand side section in which the tube bundle is located is called the EVAPORATOR.

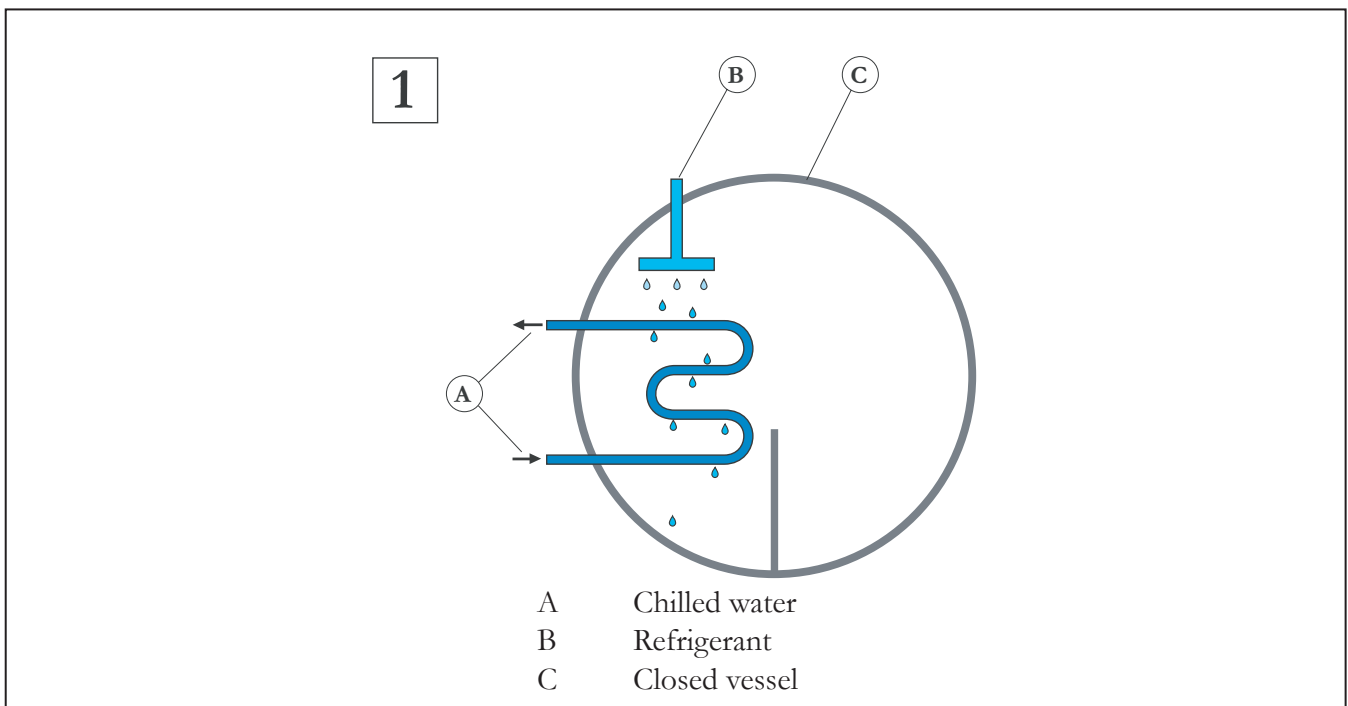

2. The right hand side location houses the ABSORBER section. In this section an aqueous concentrated solution of lithium bromide is sprayed. The solution is hygroscopic, maintaining

the shell vacuum and the weak solution of lithium bromide is collected in the base. The process of absorption produces heat and this is removed by the cooling water tube bundle.

SS SERIES

Steam fired single effect absorption chillers

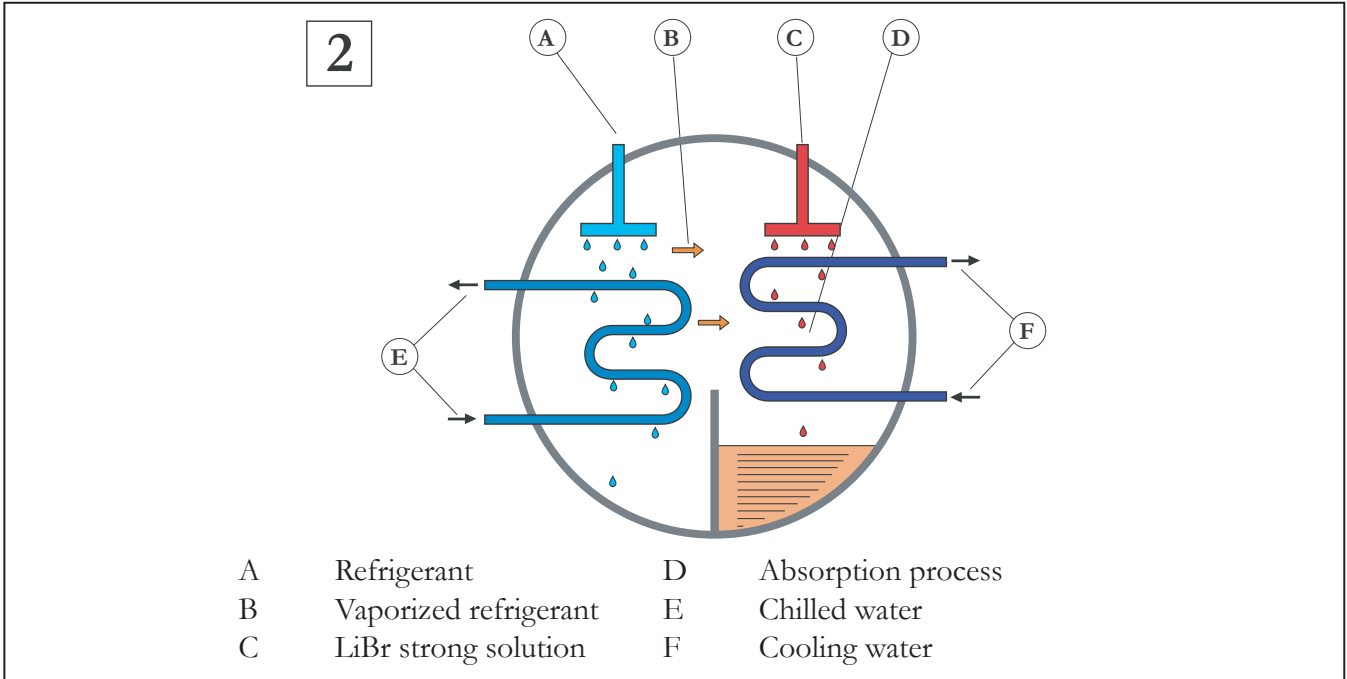

3. Hygroscopic properties of the aqueous solution of lithium bromide depend on two factors:
- Temperature: the affinity between lithium bromide and water increases as temperature decreases.
 - Concentration: as this reduces its hygroscopic effect decreases.

The collected diluted solution of lithium bromide has to be re-concentrated. It is pumped to a dedicated vessel called GENERATOR. Heat is applied through a tube bundle to vaporize the water from the diluted solution. Hot water, steam or the direct combustion of fuel is used depending on type of machine.

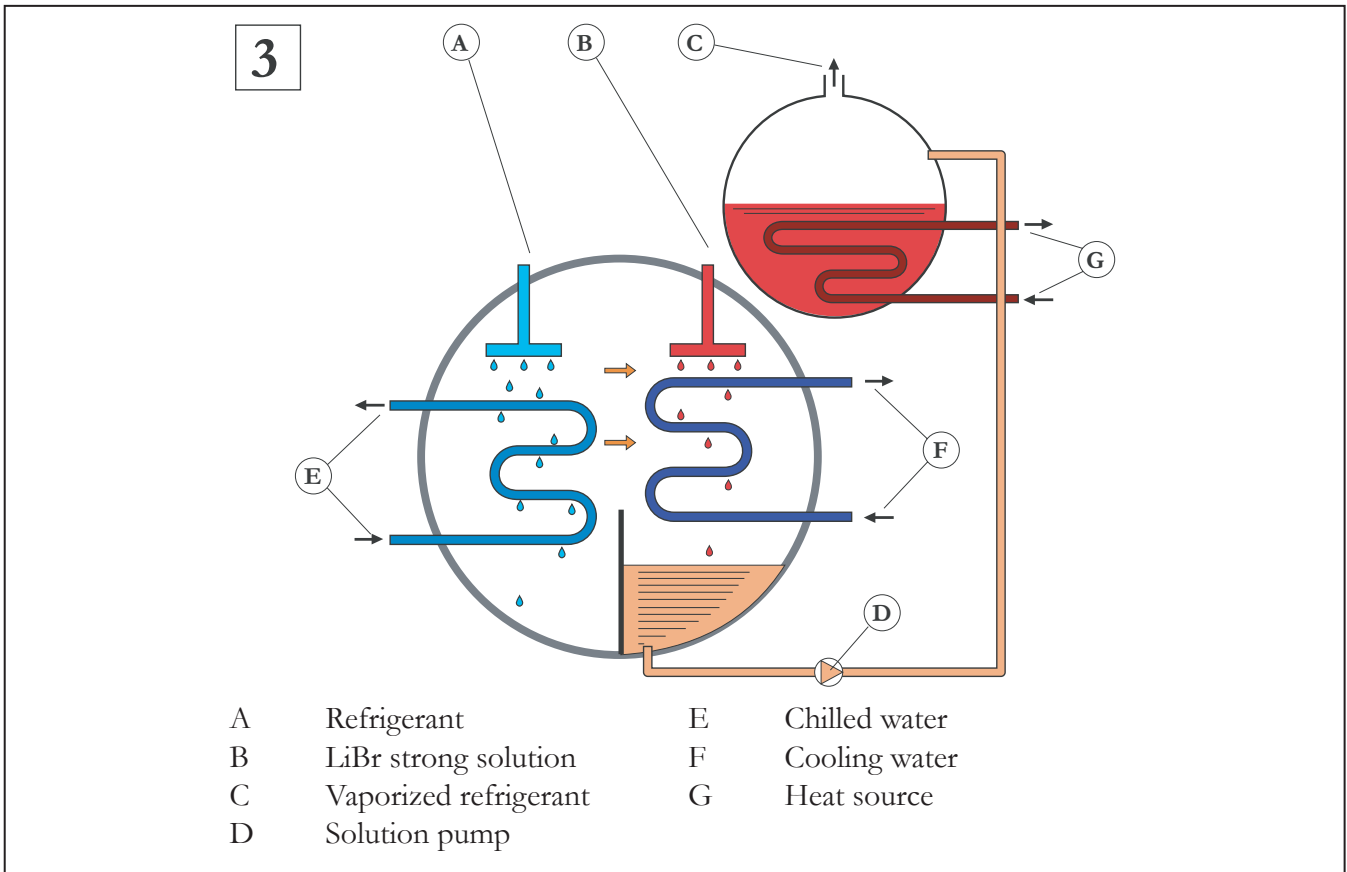

SS SERIES

Steam fired single effect absorption chillers

4. The water vapours are pumped to another heat exchanger called CONDENSER where they are condensed by a cooling water flow (the same water that is flowing in the absorber).

This condensed water is used as refrigerant to be sprayed in the evaporator to generate the cooling effect. Therefore, the working cycle of the machine is completely closed.

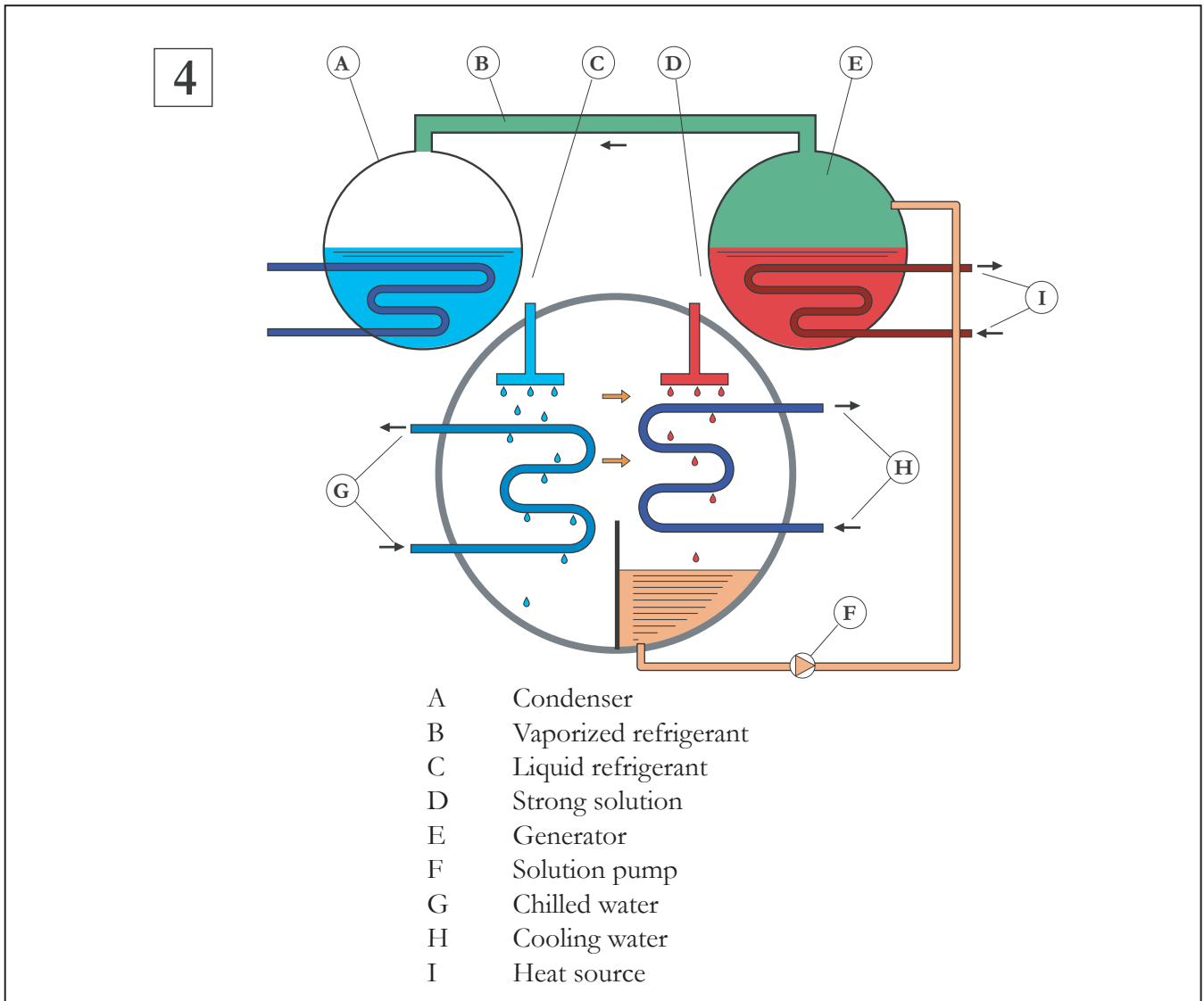

SS SERIES

Steam fired single effect absorption chillers

5. Basic working cycle for a single effect absorption chiller.

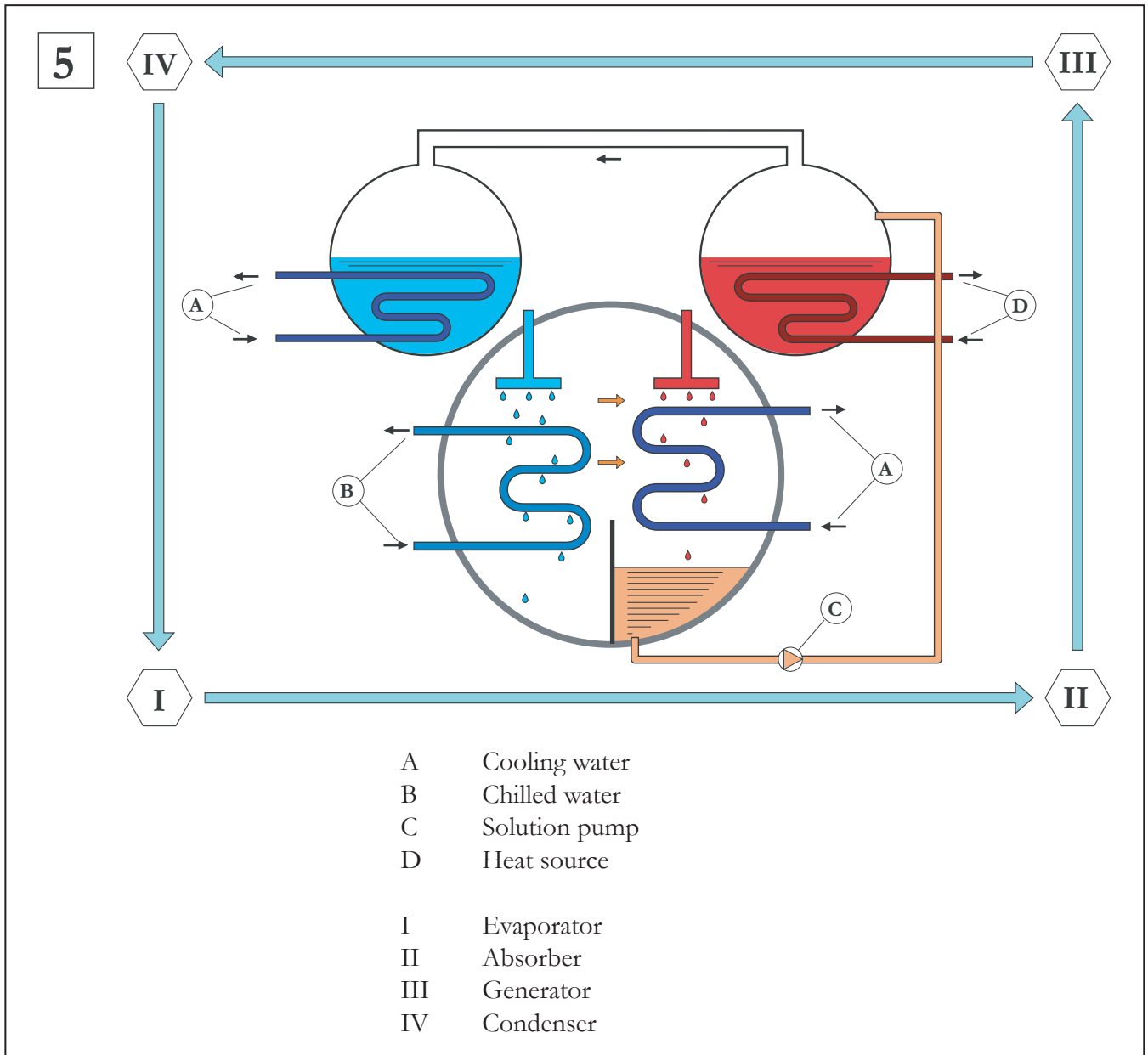

SS SERIES

Steam fired single effect absorption chillers

CYCLE DESCRIPTION

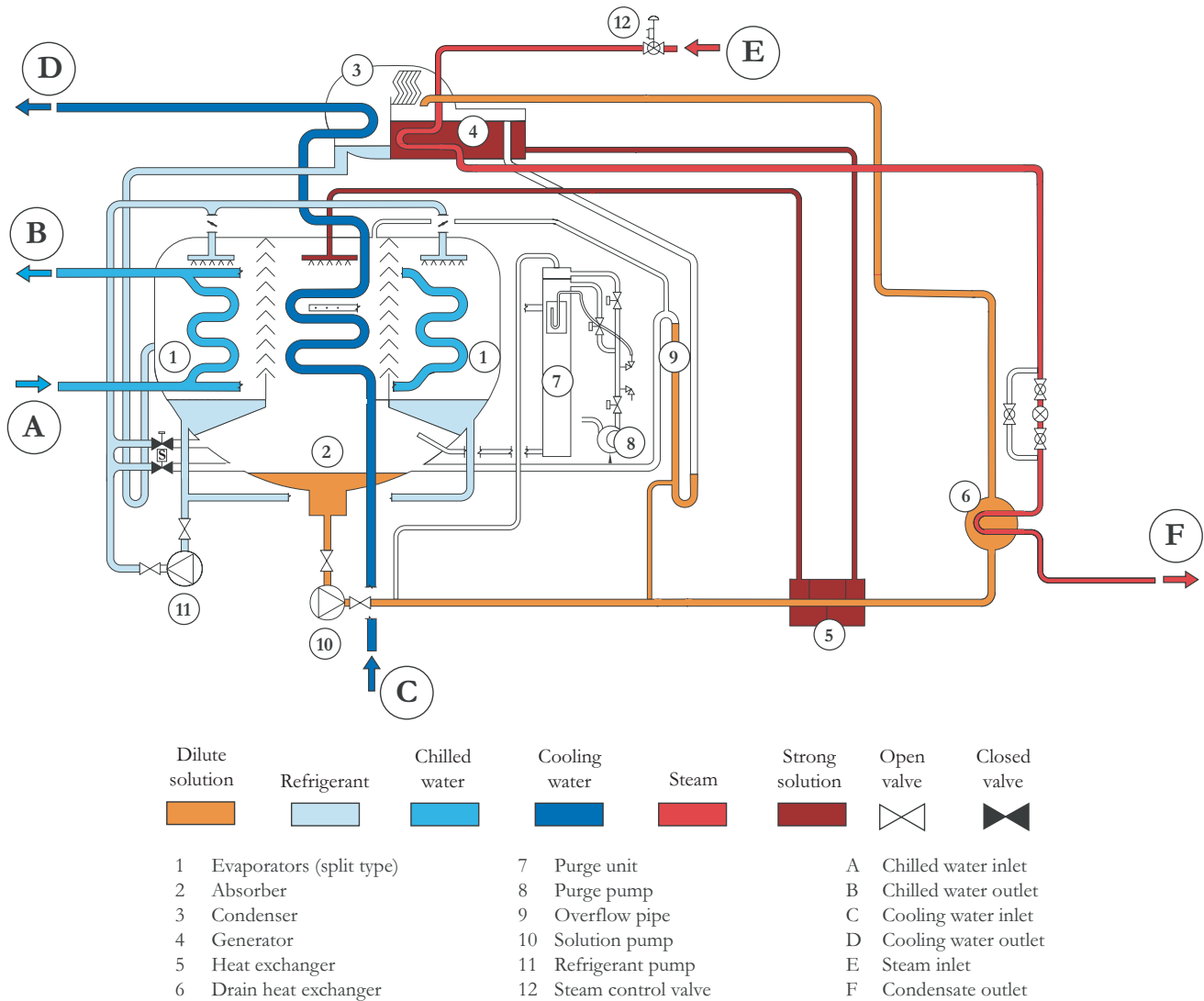

Generator

Inside this heat exchanger the dilute LiBr solution is warmed up by the steam flowing inside the tubes. Thanks to the heat, the solution starts boiling and its concentration and temperature increase. Therefore, at the outlet of the generator this concentrated solution and refrigerant vapors are available.

Heat exchanger

The hot concentrated solution coming from the generator is sent to the absorber after that it is passed through a recovery heat exchanger. Inside this one, the concentrated solution preheats the dilute solution coming from the absorber and going to the generator. The concentrated solution temperature decreases. The use of this heat exchanger leads to an

overall increase of the efficiency of the machine.

Absorber

Once the solution has reached the absorber, it is sprayed onto the tube bundle where the cooling water is flowing in the inside. The concentrated solution drops absorb all the vapors generated in the evaporator section, so that the pressure inside the shell is kept constant. The LiBr solution gets diluted. From here the solution is pumped to the generator where it is concentrated again by the heat source used in the machine. As already seen before, cooling water is flowing inside absorber tubes, since the absorption of the water in the LiBr solution is an exothermic process. The heat generated in this process is called dilution heat. If this heat is not

SS SERIES

Steam fired single effect absorption chillers

removed from the machine, the solution temperature will increase and consequently the solution affinity towards the water will decrease. So, at the end the absorption process will become less effective.

Condenser

The refrigerant vapors coming from the generator enter the condenser where they are condensed by the cooling water circulating inside the tubes. The liquid refrigerant collects on the bottom of the condenser and it is sent to the evaporator.

Evaporator

The refrigerant coming from the condenser enters the evaporator which is at a lower pressure than the condenser; for this reason the refrigerant flash cools down to 3,7°C that is the boiling temperature corresponding to the pressure inside the shell and then it falls on the evaporator tubes. Once it is collected on the bottom, it is pumped by the refrigerant pump to the distribution trays of the evaporator, from where it drops upon the tube bundle due to the gravity. As the refrigerant gets in touch with the tubes, it evaporates taking away the heat from the water circulating inside the tubes. This water is so cooled down to the required temperature.

MAIN FEATURES

- Double shell design: the upper shell (including the condenser and the generator) and the lower shell (including the evaporator and the absorber).
- In case of single shell design, the evaporator is on top of the absorber. Any non condensable gas released in the absorber section will rise up and there is a possibility that these gases are trapped below the bottom of the separation trap, and they can given time corrode the separation plate. Whereas in case of a double shell design, the evaporator and the absorber are located side by side, and therefore the possibility of the separation plate corrosion is eliminated. This shell design type calls also for higher chances of internal short circuiting as when the water level in the evaporator is very high (and consequently the solution concentration is very high) the refrigerant can directly flow into the absorber and the concentration of the solution is reduced.
- Completely factory assembled and wired. For transport facility bigger models may be shipped in two pieces. Always for transport facility control panel may be shipped loose.
- Leak tested in every part: upper and lower shell, solution heat exchanger, solution and refrigerant canned pumps, vacuum pump and purge assembly.
- PLC based control.
- LiBr solution, refrigerant, corrosion inhibitor and octyl alcohol separately provided to be charged on site.
- Nitrogen is charged into the machine at a pressure slightly higher than atmospheric prior to shipping, in order to avoid air entering the machine and damaging the internals.
- Lifting lugs provided on each side of the machine.

MECHANICAL FEATURES

LOWER SHELL

The lower shell assembly houses the evaporator and the absorber sections. They are shell and tube type heat exchangers, housed in a common fabricated carbon steel shell.

- Stainless steel eliminator plates between the evaporator and the absorber, in order to permit only to the refrigerant vapors to flow to the absorber, retaining the liquid in the evaporator.
- “Split” type evaporator: the evaporator is divided into two different tube bundles, placed on both sides of the absorber, that remains in the middle of the two evaporators. This solution grants a better efficiency at part load, optimizing the mass transfer inside the solution.
- Finned and thin wall DLP (Deoxidized Low Phosphorous) copper tubes in the evaporator. In DLP copper the oxygen is removed and the phosphorous content is less than 0,005 ppm. The presence of phosphorous greater than 0,005 ppm in the tubes of the absorption machines can result in “Stress Corrosion Cracking”. At a microscopic level, stress corrosion cracking takes place on the external surface of the tubes

SS SERIES

Steam fired single effect absorption chillers

by the attack of a salt (e.g. LiBr) on the grain boundary.

- Mini-finned and thin wall DLP (Deoxidized Low Phosphorous) copper tubes in the absorber. In DLP copper the oxygen is removed and the phosphorous content is less than 0,005 ppm. The presence of phosphorous greater than 0,005 ppm in the tubes of the absorption machines can result in “Stress Corrosion Cracking”. At a microscopic level, stress corrosion cracking takes place on the external surface of the tubes by the attack of a salt (e.g. LiBr) on the grain boundary.
- All the tubes fitted in the respective tube sheets are duly expanded for the correct fit. All the tubes are individually accessible and replaceable from either end of the chiller.
- Carbon steel tube sheets.
- Carbon steel absorber and evaporator headers fully removable at either side of the machine, for easy access to the tube bundle. Headers are provided with flanged nozzles.
- Absorber and evaporators headers with side nozzles, to grant an easy maintenance and reduce the machine break down time.
- Hinged type absorber headers, for an easy access to the tube bundle without need of lifting systems to support the header.
- Counter flanges provided as a standard feature with the unit.
- Plugged vents and drain connections provided for the water boxes.
- Sight glasses respectively on the evaporator and the absorber shell. These glasses are used to monitor the refrigerant and the solution levels in the evaporator and the absorber for an easy and user friendly operation, since through them it is possible to monitor the correct working of the machine.

UPPER SHELL

The upper shell assembly houses the condenser and the generator sections. They are shell and tube type heat exchangers, housed in a common fabricated carbon steel shell.

- Stainless steel eliminator plates between the condenser and the generator, in order to permit only the refrigerant vapors to flow to the condenser; the retained solution drops to

the bottom of the generator, thus reducing the chance for the solution contaminating the pure refrigerant.

- Plain and thin wall DLP (Deoxidized Low Phosphorous) copper tubes in the condenser. In DLP copper the oxygen is removed and the phosphorous content is less than 0,005 ppm. The presence of phosphorous greater than 0,005 ppm in the tubes of the absorption machines can result in “Stress Corrosion Cracking”. At a microscopic level, stress corrosion cracking takes place on the external surface of the tubes by the attack of a salt (e.g. LiBr) on the grain boundary.
- Stainless steel SS 430 Ti tubes in generator.
- Straight type tubes in generator: expansion coefficients of the material of tube sheet and tubes are very similar, avoiding the rise of dangerous mechanical stress due to thermal expansion, without the use of “U” type tubes or mobile supports.
- All the tubes fitted in their respective tube sheets are duly expanded for the correct fit. All the tubes are individually accessible and replaceable from either end of the chiller.
- Carbon steel tube sheets.
- Carbon steel condenser and generator headers fully removable at either side of the machine, for easy access to the tube bundle. Headers are provided with flanged nozzles.
- Condenser headers with side nozzles, to grant an easy maintenance and reduce the machine break down time.
- Hinged type condenser headers, for an easy access to the tube bundle without need of lifting systems to support the header.
- Counter flanges provided as a standard feature with the unit.
- Plugged vents and drain connections provided for the water boxes.
- Sight glass on the generator shell. This glass is used to monitor the solution level in the generator for an easy and user friendly operation, since through them it is possible to monitor the correct working of the machine.

HEAT EXCHANGERS

- The units are provided with two regenerative heat exchangers to increase the efficiency of the

SS SERIES

Steam fired single effect absorption chillers

cycle.

1. A solution heat exchanger is an integral part of the machine to increase efficiency by pre-heating weak solution with strong solution. This shall be a plate type heat exchanger. The plates shall be of stainless steel with copper brazing.
2. A heat reclaimer shall be an integral part of the machine to increase efficiency by pre-heating weak solution with steam condensate from high temperature generator. This shall be a shell and tube type heat exchanger with SS 430Ti tubes.

PURGE ASSEMBLY

- The units are provided with a purge system which is able to continuously and automatically remove non condensable gases from the inside of the machine, storing them into the storage tank. This one is divided in two parts: a first chamber where gases coming from the inside of the machine enter, and a second chamber that is the real storage tank. A small pipe connected to the solution pump discharge sends a small quantity of solution in the first chamber. The discharge of this liquid is pinched to create a jet effect. Due to this jet effect the area surrounding the pipe connection has a negative pressure. Since this chamber is connected to the main

shell of the machine, gases are sucked from the machine inside and sent to the purge device. Once the gases are inside, they are taken to the bottom of the chamber by the solution spray and they are then released in the storage tank. Here they are kept until the purge pump is not activated.

- The purge pump is provided as a standard feature on all machines. The storage tank has to be evacuated before it gets completely full.

SOLUTION AND REFRIGERANT PUMPS

- All the machines are provided with Japanese manufactured canned pumps, Teikoku made, self lubricating, factory mounted and wired. Teikoku is a world leader in the manufacturing of this type of pumps and it is well known all over the world for extremely high quality standards.
- All the pumps are provided with TRG, a patented bearing monitoring system for monitoring the consumption of the bearings. By simply connecting to a couple of free contacts in the terminal strip of the control panel it is possible to have an indication on the bearing status, without opening the canned motor pumps. The canned motor pumps are provided with over-current and high temperature protection safeties

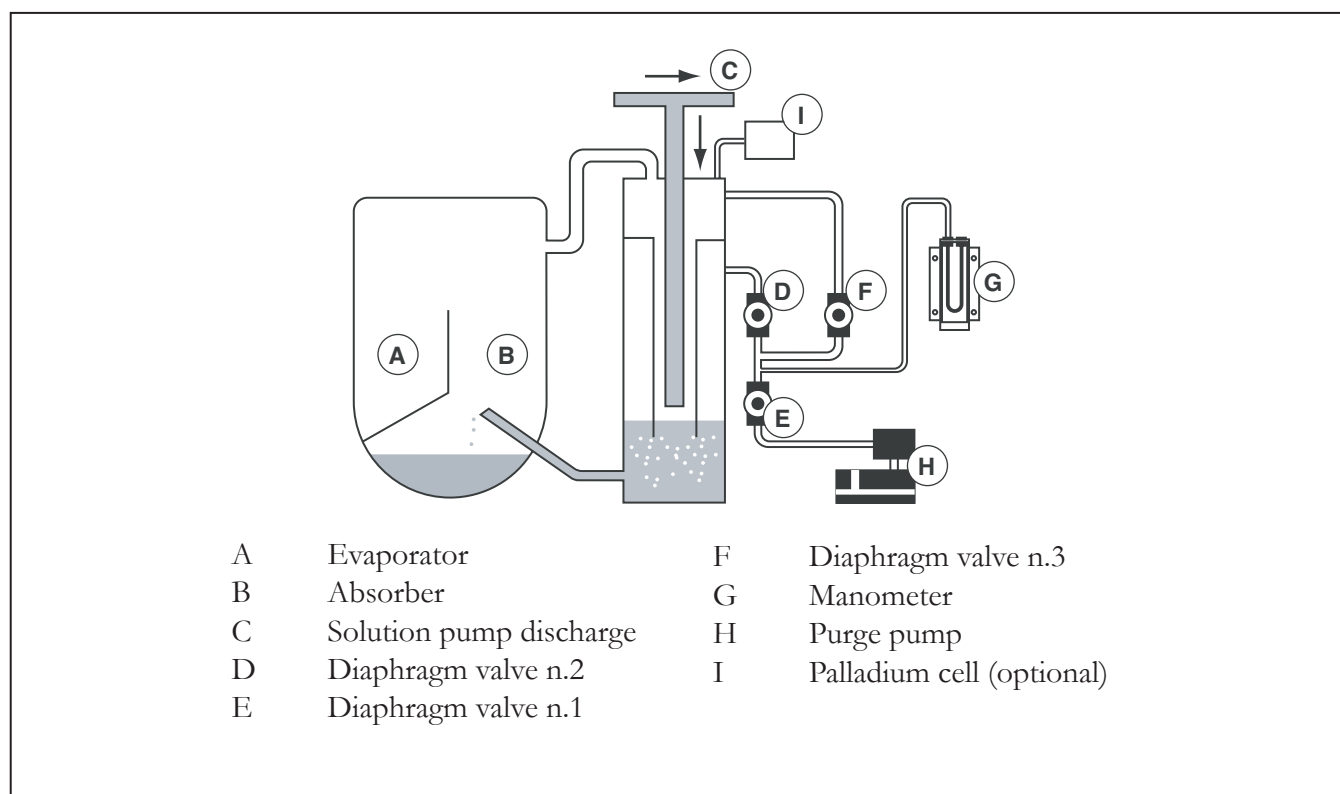

SS SERIES

Steam fired single effect absorption chillers

to prevent the motors from burnout.

- These pumps are of a bolted construction so that if required bearing and filters can be cleaned. In case of hermetically sealed pumps replacement of entire pump is the only solution. There is great difference in leak rates caused by moving seal joint and fix seal joint. Canning avoids moving seal joint as pump has no shaft seal. Back cover plate fitted for dismantling the pump does not come in contact with any moving parts. Such fixed sealing allows leak rate to be maintained within international standards without comprising the maintainability.
- The pumps are also provided with isolating valves at their suction and discharge ends to ease the removal of the pumps during maintenance without breaking the vacuum inside the chiller.
- Solution pump is also provided with an AC drive as a standard feature, to have superior performance at part load operation.

CROSSOVER PIPING

- All the various sections of the machines are interconnected by suitably sized seamless carbon steel piping. All the piping is of welded construction complete with necessary valves and fittings. The absorber to the condenser crossover piping suitably welded is a standard

feature of all the machines.

AUTOMATIC DECRYSTALLISATION SYSTEM

- The machines are provided with an auto-decrystallisation line, protecting themselves from crystallisation during operation. If crystallisation occurs, it starts inside the concentrated solution at the outlet of the heat exchanger, where the concentration is higher and the temperature is lower. Here the crystallisation would cause a partial blockage of this line that would reduce the outflow of the concentrated solution from the generator. For the automatic decrystallisation a U-tube is provided connecting the generator to the absorber, bypassing the heat exchanger. The accumulation of the concentrated solution in the generator causes the solution level to rise. The overflow of the hot concentrated solution from the generator to the absorber warms up the weak solution. This heated weak solution warms up the crystallised solution on the opposite side of the heat exchanger. Thus the crystals melt enabling the normal flow of LiBr solution through the heat exchanger.

ANTICRYSTALLISATION SYSTEM

- The machines are also provided with an advanced

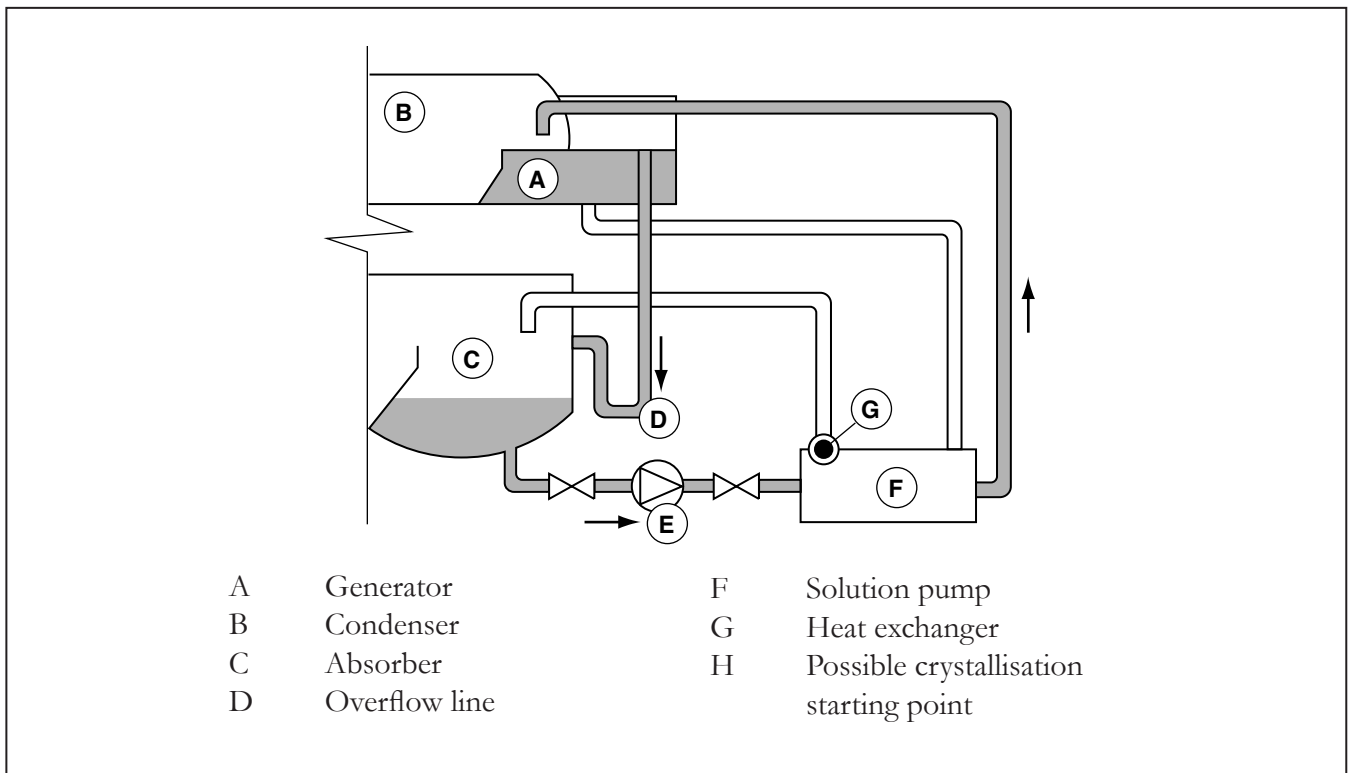

SS SERIES

Steam fired single effect absorption chillers

state of the art active concentration control. By means of a series of different sensors, machine's PLC is able to calculate in every moment the maximum solution concentration inside the machine and compare it with the calculated critical value. If actual concentration is too close to the critical value, concentration control system takes the control of the machine, modulating the control valve to take the concentration level back to safe values. A decrystallisation system starts acting when crystallisation has already taken place: the Thermax concentration control instead ensure that machine will always work far away from crystallisation area.

- Thanks to this concentration control system it is possible to operate the chiller with cooling water inlet temperatures as low as 10°C.

GRAVITY FEED TRAYS

- The machines are provided with a gravity feed tray system, composed of a series of steel drilled trays for the distribution of the refrigerant and the solution over the respective tube bundles. These gravity feed trays are located just above the top of the respective tube bundle and have perforations perfectly aligned with and running along the entire length of the tube bundle. This gravity feed arrangement enhances high degree reliability in operation and longer machine life by eliminating the erosion of the spraying nozzles and the disruption of flow due to the clogging of the nozzles with impurities. Furthermore this system doesn't require a supplementary solution pump to provide extra pressure to win the pressure drop generated by the nozzles of a spray system.

CAPACITY CONTROL

- Stepless and continuous capacity control from 10% to 100%, based on the chilled water outlet temperature. The chilled water flow to the chiller is kept constant. So the cooling capacity is proportional to the temperature difference between the inlet and the outlet water temperature. Load fluctuations reflect in increasing or decreasing of the inlet chilled water temperature, and consequently of the outlet one. A sensor on the chilled water outlet senses the temperature change and gives a

control signal. The signal is electrically amplified by a PLC and converted into a 4-20mA control signal by a PID algorithm, then it goes to the actuator of the control valve. As the load starts increasing, the control valve starts opening and closes as the load decreases.

CORROSION INHIBITOR

- A proper corrosion inhibitor is added to the solution to minimize the possibility of any corrosion taking place in the machine. A large number of first generation absorption machines used lithium nitrate or chromate as the corrosion inhibitor. But the nitrate desiccates at high temperatures, becomes instable and can lead to the generation of ammonia, while the chromate is toxic. These machines use the lithium molybdate as corrosion inhibitor, since it has excellent corrosion inhibitor properties, it doesn't desiccate at high temperatures and it is not toxic.

REFRIGERANT BLOWDOWN VALVE

- A refrigerant blow down valve placed between the evaporator and the absorber to allow the by pass of refrigerant from one to the other. The refrigerant vapors generated in the generator are always contaminated with small solution drops that are continuously stopped by the eliminators. In spite of them a small quantity of solution always remains with the refrigerant and goes to the condenser. As the quantity of solution in the refrigerant increases, the machine will slowly but continuously reduce its capacity. In fact during the refrigerant evaporation in the evaporator, the LiBr solution is not effective in the heat transfer process and so the capacity will be reduced. For this reason the refrigerant blowdown valve has to be operated on a periodic basis.

ABSORBER SOLENOID VALVE

- A solenoid valve is provided in absorber, connected with the refrigerant piping. When the solution level in absorber goes below a set value, the solenoid valve on refrigerant line gets open and refrigerant is directly sent to absorber, so that the solution pump can send the proper quantity of dilute solution to the generator, in order to keep under control the concentration.

SS SERIES

Steam fired single effect absorption chillers

REFRIGERANT AND SOLUTION LEVELS CONTROL

- All the units are provided with reliable level electrodes to control the refrigerant level in the evaporator and the solution level in absorber. These electrodes ensure that the correct signal is given to the control panel to avoid that refrigerant and solution pump will enter into a cavitation zone and to ensure that the correct quantity of solution is pumped inside the machine. They are more precise and reliable than the traditional floating system.

RUPTURE DISK

- All the machines are provided with a rupture disk as a standard feature. It is mounted on the shell side of the generator. When the pressure inside the generator raises above the critical value, the disk bursts open releasing the pressure inside, avoiding any major damage to the machine.

FACTORY TESTS

SOAP TEST

- Nitrogen is charged into the machine at a pressure up to 130 to 140 kPa. After charging is over, test is carried out with soap solution. A soap solution is spread evenly over the joints and on the expanded tube ends. If there is any leakage the nitrogen will try to leak from the joint, and because of the soap solution, bubbles will be formed. These leak points are marked

and repaired/rewelded.

DECAY TEST

- After repairing the leaks found out during nitrogen testing, the machine is again charged with nitrogen up to 130 kPa pressure. The machine is kept at this pressure for 24 hours. If any leakage occurs nitrogen will escape to the atmosphere and the pressure will start reducing thus showing the leakage. If a leakage is found in the decay test, the joints are thoroughly rechecked as in the previous step and they are repaired.

HELIUM SPRAY TEST

- The helium molecule is the next smallest molecule after the hydrogen molecule in the periodic table and it will leak through very minute holes. The absorption machine is fully evacuated (vacuumed). After vacuuming, the machine is connected to a special helium leak detector. The helium is spread on all the joints. As the machine is under vacuum, a leakage in the joints will result in helium entering into the machine which will be shown on the screen of the helium leak detector. If the cumulative leak rate is more than 1×10^{-7} standard cc/sec. then the joints are marked and repaired.

HELIUM SHROUD TEST

- The machine is fully covered by a polythene sheet and the helium is passed under the polythene cover. The leak rate is observed in the leak

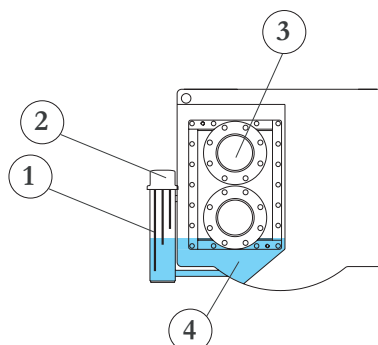

- 1 Level electrodes
- 2 Refrigerant level control system
- 3 Evaporator
- 4 Refrigerant

SS SERIES

Steam fired single effect absorption chillers

detector machine for 30 minutes. In this test, the leak rate allowable is up to 1×10^{-7} standard cc/s.

CONTROLS AND SAFETIES

GENERAL FEATURES

The units come with a Siemens S7/1200 Programmable Logic Controller (PLC), provided with the most advanced technological features to grant safe and economic operation, in order to make these products highly efficient, reliable and user friendly.

The control equipment is enclosed in a rugged dust proof sheet metal casing mounted on the chiller with IP42 protection. The control panel consists of the following:

- Main circuit breaker for safety against electrical hazards.
- Terminal blocks for control and power connections.
- Microprocessor based PLC Siemens S7/1200 for operational logic and sequence, safety and capacity control through PID algorithm. PLC uses a powerful CPU Siemens 1215C.
- 7" touchscreen display Siemens TP700.
- Modbus RTU connectivity.
- Ultra isolation control transformer with MCB protection for control circuit.
- Level electrodes for refrigerant level monitoring in the evaporators and solution level monitoring in absorber.
- Individual contactors and thermal overcurrent relays for all pumps motors.
- Interlocks for chilled and cooling water pumps.
- Temperature sensors and display for the following:
 - Chilled water inlet and outlet.
 - Cooling water inlet and outlet.
 - Concentrated solution at generator outlet.
 - Concentrated solution sprayed in absorber.
 - Condensed refrigerant in "U" tube.
- Antifreeze protection safeties (PLC inbuilt antifreeze alarm, antifreeze thermostat, low temperature cut-out for the refrigerant pump (L-cut), flow switch and a D.P. switch for chilled

water).

- Crystallisation prevention (low cooling water inlet temperature cut-out, high temperature control for generator, control valve PLC regulation based on generator temperature, active concentration control for safe operation with low cooling water inlet temperatures, solution level control in absorber for solenoid absorber valve opening).
- Alarm state annunciation through an audio signal and appropriate messages display on the operator interface terminal.
- Last 24 hour logging facility at a sampling time of one hour intervals and last six alarms logging facility are provided for better understanding of the behavior of the unit during alarm conditions and for easy diagnosis.
- Possibility to modify data logging frequency time and make it faster after an alarm is activated.
- Machine status indication on the display.
- Possibility to connect to the client BAS/BMS/DCS systems with PPI communication protocol, compatible with Modbus RTU slave.

CONTROL AND SELF DIAGNOSTIC FUNCTIONS

The control panel has the following functions:

- Remote and local access for sequential operation of the chiller.
- Steam consumption control by a tight control of the chilled water outlet temperature accomplished by a microprocessor PID algorithm. This algorithm allows the machine to keep the chilled water temperature fluctuations within the set values by continuously modulating the control valve and allowing to partialize the load from 10 to 100% of the nominal value. Keypad variation of the set point is possible to get a minimum of 3,5°C outlet chilled water temperature.
- Status indication with audio visual alarm for malfunction.
- Thermal shock protection: in order to avoid dangerous thermal shock of the tubes material, at machine starting the PLC control system generates a 4-20 mA control signal that gradually opens the control valve without taking care of outlet chilled water temperature. This signal starts only if the outlet chilled water temperature

SS SERIES

Steam fired single effect absorption chillers

is more than the set point one. After 7 minutes, the control is switched over to chilled water temperature modulation automatically.

- Nuisance trip prevention anti chattering timer delays tripping of chilled water flow switch and differential pressure switch by a few seconds, in order to avoid dangerous starting and stopping of the machine due to fluctuations in the chilled water flow.

SAFETY FUNCTIONS

The safety functions protect the machine from abnormal working conditions. The different safety functions are as follows:

- Thermal shock protection
- Antifreeze protection
- Crystallisation protection.
- Cavitation protection of refrigerant pump
- Motors protection

- Thermal shock protection

In order to avoid dangerous thermal shock to the tube material, at machine starting the control valve is gradually and slowly opened for the first 7 minutes, when the generator temperature is very low irrespective of the outlet chilled water temperature. After 7 minutes, the control is switched over to chilled water temperature modulation automatically.

- Antifreeze protection

In order to prevent the chilled water freezing in the evaporator tubes, the following functions stop the machine in abnormal conditions leading to the formation of ice:

L-cut. If the chilled water outlet temperature drops below the L-cut set point, the refrigerant pump is switched off. This prevents a further temperature drop of the chilled water below the set value.

Internal antifreeze thermostat. If the chilled water outlet temperature drops below the internal antifreeze set point, the machine trips.

Antifreeze thermostat. If the chilled water outlet temperature drops below the antifreeze thermostat set point the machine trips.

Chilled water pump interlock. The chilled water flow is essential for the machine operation. A potential free contact is to be wired from the chilled water pump motor starter or from one flow switch (in customer scope) to the machine panel to sense the chilled water pump on/off/trip status. The machine starts only if the chilled water pump is on. In case the chilled water pump trips and in order to avoid the freezing of the static chilled water in the tubes inside the machine, it is mandatory to stop the cooling water pump. For this reason it is mandatory that

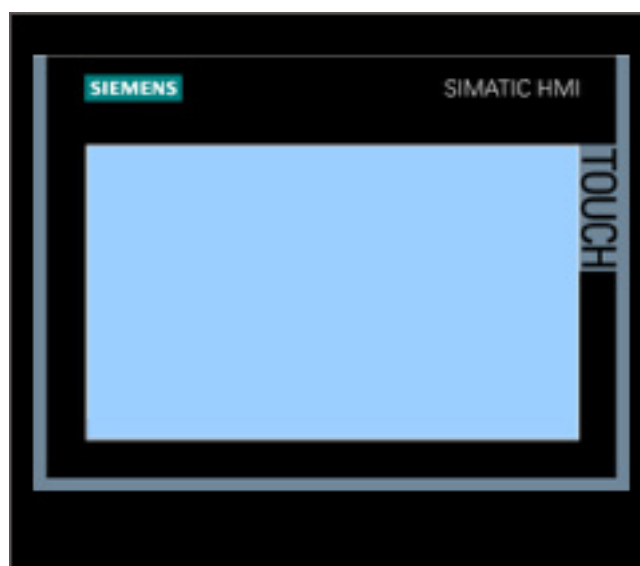

SS SERIES

Steam fired single effect absorption chillers

the PLC has control over the chilled and cooling water pumps. Four potential free contacts are provided in the panel to control the pumps switching on and off.

Chilled water differential pressure switch. If the chilled water flow drops below 50% of the rated value, machine trips.

Chilled water flow switch. If the chilled water flow drops below 50% of the rated value, machine trips.

- Crystallisation prevention

If the concentrated solution returning to the absorber from the generator is excessively cooled, it crystallises in the heat exchanger and the operation of the machine is affected. Crystallisation occurs either when the concentration of the solution (for a particular temperature) goes too high or its temperature (for a particular concentration) goes too low. The following safety functions prevent the machine from crystallising:

Control valve. When the generator temperature is more than the critical temperature set in the PLC, the control valve immediately closes. This is to avoid a further increase in concentration.

Generator high temperature safety. If the generator temperature exceeds the generator high temperature set point, the machine trips.

Cooling water low temperature safety. If the cooling water inlet temperature drops below the cooling water low temperature set point, the machine trips.

Active concentration control. By means of a series of different sensors, machine's PLC is able to calculate in every moment the maximum solution concentration inside the machine and compare it with the calculated critical value. If actual concentration is too close to the critical value, concentration control system takes the control of the machine, modulating the control valve to take the concentration level back to safe values.

Level electrodes in absorber. When the solution level in absorber goes below a set value, the solenoid valve on refrigerant line gets open and refrigerant is directly sent to absorber. When the solution level goes below the minimum set, the control valve is closed until the level has raised to a safety level.

- Cavitation protection of refrigerant pump

If the refrigerant level in the evaporator pan falls excessively, the pressure in the refrigerant pump suction drops below the saturation pressure of the refrigerant and the refrigerant pump starts to cavitate. To ensure the minimum acceptable suction pressure the level of the refrigerant is not allowed to fall below a certain level. This is done by means of three level electrodes RE1, RE2, RE3 and a level relay, 33RL.

The three electrodes are mounted in the refrigerant level box assembly on the lower shell (evaporator side). RE1 electrode is the smallest in length and RE3 is the longest. The level is maintained between RE1 and RE2. RE3 acts as a reference electrode. When the level reaches RE1, the pump starts and when goes below RE2, the pump stops and restarts only when the level reaches RE1 again. When the level goes below RE2, a delay of 20 seconds is provided before the pump is switched off.

- Motors protection

Solution, refrigerant and purge pump overload relay.

INFORMATION DISPLAY

Operating information is in English language with SI units. Standard information shown are:

- Chilled water inlet and outlet temperatures.
- Cooling water inlet and outlet temperatures.
- Concentrated solution temperature at generator outlet.
- Concentrated solution temperature sprayed in absorber.
- Condensed refrigerant temperature in "U" tube.
- Percentage opening of control valve.
- Machine operating hours.
- Purge pump operating hours.
- Date of last purge cycle.

FUNCTIONAL COMMANDS

- Chiller remote/local mode.
- Chiller start/stop in local access.
- Refrigerant pump auto/manual mode.
- Refrigerant pump start/stop in manual.
- Purge pump start/stop.
- Control valve auto/manual mode.

SS SERIES

Steam fired single effect absorption chillers

- Control valve open/close in manual.
- Alarm acknowledge.
- Alarm reset.
- Maximum opening of control valve setpoint.

STATUS DISPLAY

- Chiller on/off/In dilution cycle.
- Chiller local/remote mode.
- Chilled water flow switch healthy/trip.
- Chilled water differential pressure switch healthy/trip.
- Chilled water interlock healthy/trip
- Temperature sensors healthy/trip.
- Chilled water antifreeze thermostat healthy/trip.
- Cooling water pump on/off/trip.
- Cooling tower fans ON/OFF (if wired).
- Solution pump on/off/trip.
- Refrigerant pump auto/manual mode.
- Refrigerant pump on/off/trip.
- Purge pump on/off/trip.
- L-cut function healthy/trip.
- Control valve status.
- Refrigerant level indication in the evaporator.

POTENTIAL FREE CONTACTS FOR REMOTE WORKING

- Remote machine start/stop.
- Remote machine status indication (On/Off).
- Remote machine trip indication.

ACCESSORIES

- Special tubes material for shell and tube heat exchangers, based on the water quality circulating in the tubes. Materials available are:
 - Cupro-Nickel
 - Stainless steel
 - Titanium
- On request the machine can be provided with a palladium cell to automatically evacuate the hydrogen from the machine. The inside walls of this cell are made with palladium. The main device of this material is that at high temperatures it becomes porous to hydrogen. When the electric heater is switched on, palladium tubes get heated and hydrogen (most of the non condensable gases inside the machine are hydrogen) is evacuated from the cell directly into the atmosphere. In this way a vacuum inside

the machine is automatically maintained using a completely static system.

- Automatic purge system.
- Insulation of hot and cold surfaces directly done at factory.
- TRG reading directly from control panel through analogic device rather than through free potential contact is control panel.
- Two pieces shipment (lower and upper shell) for convenience of shipping and rigging, especially for retrofit jobs.
- Inverter on refrigerant pump, in case of specific installation requirements.
- Chilled water remote setpoint.
- Flexibility of connecting the chiller PLC to various BMS systems.

SS SERIES

Steam fired single effect absorption chillers

TECHNICAL DATA

MODEL	Unit	SS 20A	SS 20B	SS 20C	SS 20D	SS 30A	SS 30B	
Nominal cooling capacity	kW	469	563	737	884	1065	1202	
CHILLED WATER	Inlet/outlet temperature	°C	12/7					
	Flow	m ³ /hr	80,4	96,6	126,4	151,6	182,7	206,2
	Friction loss	kPa	25,7	33,9	75,9	55,7	68,8	35,9
	Maximum working pressure	kPa	785					
	Evaporator passes		2		1	2	1	
	Nozzle dimension	DN	125			150		
	Heat exchanger volume	l	177	188	230	247	348	369
COOLING WATER	Inlet temperature	°C	29					
	Outlet temperature	°C	39,4	39,3	37,6	37,5	37,3	37,2
	Flow	m ³ /hr	95	115	180	219	267	306
	Friction loss	kPa	49,9	51,8	62,5	70,7	58,1	62,2
	Maximum working pressure	kPa	785					
	Absorber/Condenser passes		3/2		2/1			
	Nozzle dimension	DN	150			200		
Heat exchanger volume	l	381	413	454	501	695	740	
STEAM CIRCUIT (*)	Steam consumption	kg/h	1031	1244	1600	1928	2298	2600
	Steam pressure	kPa	150					
	Steam nozzle dimension	DN	150			200		
	Condensate nozzle dimension	DN	40			50		
	Maximum working pressure	kPa	785					
	Condensate temperature	°C	80-100					
	Condensate drain pressure	kPa	19,6					
ELECTRICAL DATA	Power supply		400 V ±10%, 50 Hz ±3%, 3 phase					
	Solution pump	kW (A)	1,1 (3,4)		1,5 (5,0)		3,0 (8,0)	
	Refrigerant pump	kW (A)	0,3 (1,4)					
	Purge pump	kW (A)	0,75 (1,8)					
	Total electrical consumption	kVA	5,5		6,6		8,7	

(*) = Dry saturated steam

Fouling factor = 0,018 m² K/kW in chilled water line, 0,044 m² K/kW in cooling water line

For working conditions different from above, please contact authorized Thermax office to request a customized selection.

SS SERIES

Steam fired single effect absorption chillers

MODEL	Unit	SS 30C	SS 40A	SS 40B	SS 40C	SS 50A	SS 50B	
Nominal cooling capacity	kW	1391	1572	1779	1941	2204	2422	
CHILLED WATER	Inlet/outlet temperature	°C	12/7					
	Flow	m ³ /hr	238,6	269,6	305,1	332,9	378	415,4
	Friction loss	kPa	49,6	28,7	34,1	39	28,2	31,7
	Maximum working pressure	kPa	785					
	Evaporator passes		150	200				
	Nozzle dimension	DN	1					
	Heat exchanger volume	l	417	547	592	623	757	810
COOLING WATER	Inlet temperature	°C	29					
	Outlet temperature	°C	38,5	38,6	38,6	38,7	38,7	38,8
	Flow	m ³ /hr	306	340	385	418	474	518
	Friction loss	kPa	69,1	61,3	63,2	63,9	67,4	69,3
	Maximum working pressure	kPa	785					
	Absorber/Condenser passes		2/1					
	Nozzle dimension	DN	200	250				
Heat exchanger volume	l	813	1118	1185	1240	1474	1544	
STEAM CIRCUIT (*)	Steam consumption	kg/h	3040	3395	3847	4237	4776	5280
	Steam pressure	kPa	150					
	Steam nozzle dimension	DN	200	250				
	Condensate nozzle dimension	DN	50				65	
	Maximum working pressure	kPa	785					
	Condensate temperature	°C	80-100					
	Condensate drain pressure	kPa	19,6					
ELECTRICAL DATA	Power supply		400 V ±10%, 50 Hz ±3%, 3 phase					
	Solution pump	kW (A)	3,0 (8,0)	3,7 (11,0)				
	Refrigerant pump	kW (A)	0,3 (1,4)					
	Purge pump	kW (A)	0,75 (1,8)					
	Total electrical consumption	kVA	8,7	10,8				

(*) = Dry saturated steam

Fouling factor = 0,018 m² K/kW in chilled water line, 0,0844m² K/kW in cooling water line

For working conditions different from above, please contact authorized Thermax office to request a customized selection.

SS SERIES

Steam fired single effect absorption chillers

MODEL		Unit	SS 60A	SS 60B	SS 60C	SS 60D	SS 70A	SS 70B	
Nominal cooling capacity		kW	2798	3102	3354	3711	4224	4702	
CHILLED WATER	Inlet/outlet temperature	°C	12/7						
	Flow	m ³ /hr	479,9	532,1	575,3	636,5	724,5	806,5	
	Friction loss	kPa	24,6	27,4	39,6	43,6	45,2	50,9	
	Maximum working pressure	kPa	785						
	Evaporator passes		1						
	Nozzle dimension	DN	250				300		
	Heat exchanger volume	l	1128	1187	1305	1378	1762	1870	
COOLING WATER	Inlet temperature	°C	29						
	Outlet temperature	°C	37,7	37,7	39,4	39,4	39,4	39,4	
	Flow	m ³ /hr	674	744	674	744	849	939	
	Friction loss	kPa	98,8	101,1	115,3	117,3	111,1	119	
	Maximum working pressure	kPa	785						
	Absorber/Condenser passes		2/1						
	Nozzle dimension	DN	300				350		
Heat exchanger volume	l	2010	2125	2269	2413	3104	3236		
STEAM CIRCUIT (*)	Steam consumption	kg/h	6043	6698	7282	8083	9128	10141	
	Steam pressure	kPa	150						
	Steam nozzle dimension	DN	300				350		
	Condensate nozzle dimension	DN	65		80				
	Maximum working pressure	kPa	785						
	Condensate temperature	°C	80-100						
	Condensate drain pressure	kPa	19,6						
ELECTRICAL DATA	Power supply		400 V ±10%, 50 Hz ±3%, 3 phase						
	Solution pump	kW (A)	5,5 (14,0)		6,6 (17,0)		4,5 (13,0)		
	Refrigerant pump	kW (A)	0,3 (1,4)		1,5 (5,0)				
	Purge pump	kW (A)	0,75 (1,8)						
	Total electrical consumption	kVA	12,9		17,4		14,7		

(*) = Dry saturated steam

Fouling factor = 0,018 m² K/kW in chilled water line, 0,044 m² K/kW in cooling water line

For working conditions different from above, please contact authorized Thermax office to request a customized selection.

SS SERIES

Steam fired single effect absorption chillers

MODEL		Unit	SS 80A	SS 80B	SS 80C	SS 80D
Nominal cooling capacity		kW	5422	5942	6255	6707
CHILLED WATER	Inlet/outlet temperature	°C	12/7			
	Flow	m ³ /hr	930	1019,2	1072,8	1150,4
	Friction loss	kPa	37,4	41,5	54	57,2
	Maximum working pressure	kPa	785			
	Evaporator passes		1			
	Nozzle dimension	DN	350		400	
	Heat exchanger volume	l	2480	2578	2918	3036
COOLING WATER	Inlet temperature	°C	29			
	Outlet temperature	°C	38,1	38,3	39,5	39,4
	Flow	m ³ /hr	1245	1335	1245	1335
	Friction loss	kPa	121,9	126,7	138,7	143,8
	Maximum working pressure	kPa	785			
	Absorber/Condenser passes		2/1			
	Nozzle dimension	DN	400			
	Heat exchanger volume	l	4531	4678	5013	5190
STEAM CIRCUIT (*)	Steam consumption	kg/h	11675	12782	13489	14384
	Steam pressure	kPa	150			
	Steam nozzle dimension	DN	400		450	
	Condensate nozzle dimension	DN	100			
	Maximum working pressure	kPa	785			
	Condensate temperature	°C	80-100			
	Condensate drain pressure	kPa	19,6			
ELECTRICAL DATA	Power supply		400 V ±10%, 50 Hz ±3%, 3 phase			
	Solution pump	kW (A)	4,5 (13,0)		5,5 (17,0)	
	Refrigerant pump	kW (A)	1,5 (5,0)			
	Purge pump	kW (A)	0,75 (1,8)			
	Total electrical consumption	kVA	14,7		17,4	

(*) = Dry saturated steam

Fouling factor = 0,018 m² K/kW in chilled water line, 0,044 m² K/kW in cooling water line

For working conditions different from above, please contact authorized Thermax office to request a customized selection.

SS SERIES

Steam fired single effect absorption chillers

DIMENSIONS AND WEIGHTS

DIMENSIONS (in mm)

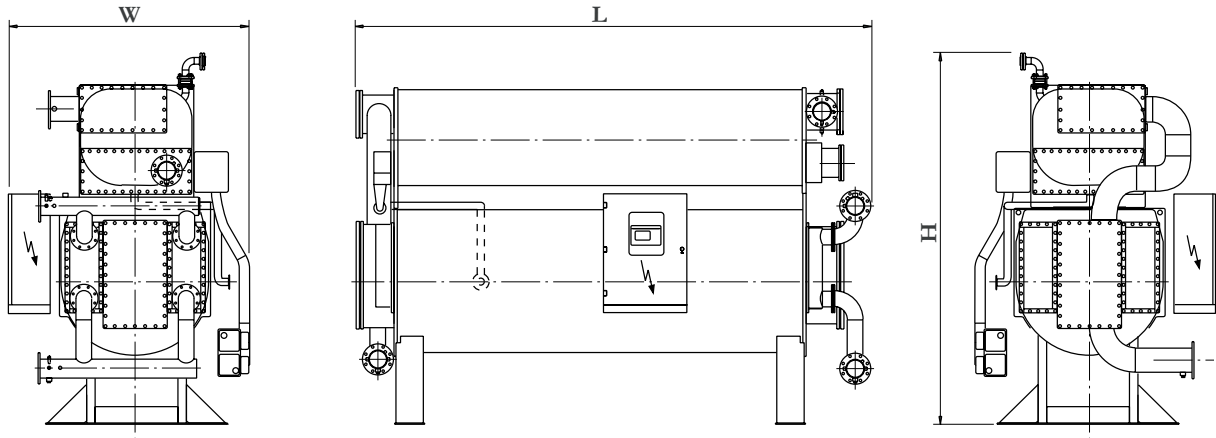

Model	SS 20A	SS 20B	SS 20C	SS 20D	SS 30A	SS 30B	SS 30C	SS 40A
Length (L)	2.950	2.950	3.995	3.995	4.135	4.135	4.745	4.930
Width (W)	1.880	1.880	1.880	1.880	2.210	2.210	2.210	2.345
Height (H)	2.830	2.830	2.830	2.830	2.945	2.945	2.945	3.315

Model	SS 40B	SS 40C	SS 50A	SS 50B	SS 60A	SS 60B	SS 60C	SS 60D
Length (L)	4.930	4.930	5.060	5.060	6.650	6.650	7.885	7.885
Width (W)	2.345	2.345	2.570	2.570	2.675	2.675	2.675	2.675
Height (H)	3.315	3.315	3.405	3.405	3.810	3.810	3.810	3.810

Model	SS 70A	SS 70B	SS 80A	SS 80B	SS 80C	SS 80D
Length (L)	7.855	7.855	8.340	8.340	9.650	9.650
Width (W)	2.860	2.860	3.360	3.360	3.360	3.360
Height (H)	4.190	4.190	4.695	4.695	4.695	4.695

SERVICE CLEARANCE (in mm)

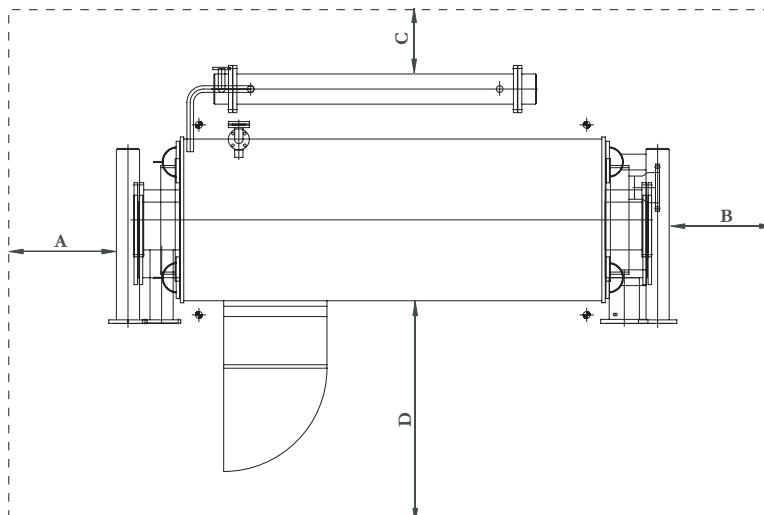

SS SERIES

Steam fired single effect absorption chillers

Model	B	C	D	TOP
All models	500	500	1.200	200

Model	SS 20A	SS 20B	SS 20C	SS 20D	SS 30A	SS 30B	SS 30C	SS 40A
A (**)	2.600	2.600	3.600	3.600	3.700	3.700	4.200	4.250

Model	SS 40B	SS 40C	SS 50A	SS 50B	SS 60A	SS 60B	SS 60C	SS 60D
A (**)	4.250	4.250	4.400	4.400	5.700	5.700	6.900	6.900

Model	SS 70A	SS 70B	SS 80A	SS 80B	SS 80C	SS 80D
A (**)	6.900	6.900	7.000	7.000	8.300	8.300

(**): "A" is the clearance space for tubes maintenance and removal. It can be left on either side of the chiller, depending on the convenience of site.

WEIGHTS (in kg)

Model	SS 20A	SS 20B	SS 20C	SS 20D	SS 30A	SS 30B	SS 30C	SS 40A
Shipping weight	4.900	5.000	5.900	6.100	7.600	7.800	8.600	10.800
Operating weight	5.400	5.600	6.600	6.800	8.600	8.900	9.800	12.500
Dry weight	4.400	4.400	5.200	5.300	6.600	6.800	7.400	9.300
Flooded weight	7.700	7.700	10.000	10.100	13.000	13.200	15.000	19.300

Model	SS 40B	SS 40C	SS 50A	SS 50B	SS 60A	SS 60B	SS 60C	SS 60D
Shipping weight	11.100	11.400	13.100	13.300	19.400	19.800	22.200	22.900
Operating weight	12.900	13.200	15.300	15.700	22.500	23.100	25.800	26.700
Dry weight	9.500	9.700	11.100	11.300	16.600	16.900	18.900	19.400
Flooded weight	19.600	19.800	23.500	23.700	34.800	35.200	41.200	41.800

Model	SS 70A	SS 70B	SS 80A	SS 80B	SS 80C	SS 80D
Shipping weight	29.200	29.800	38.600	39.000	43.300	43.800
Operating weight	34.000	34.900	45.600	46.300	51.200	52.000
Dry weight	24.300	24.800	32.600	33.000	36.300	36.800
Flooded weight	51.800	52.300	71.300	71.700	82.200	82.700

SS SERIES

Steam fired single effect absorption chillers

FOUNDATIONS

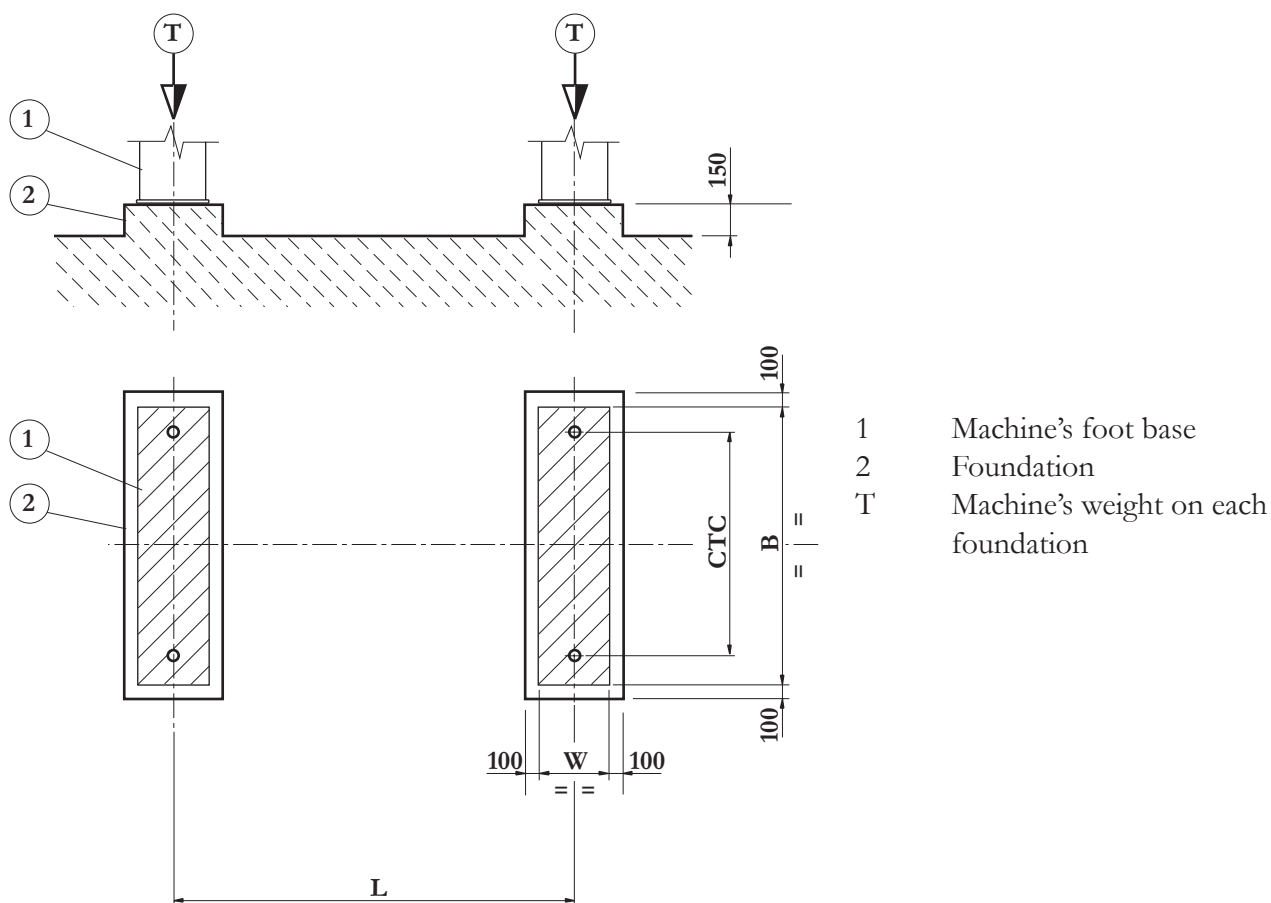

Model	SS 20A	SS 20B	SS 20C	SS 20D	SS 30A	SS 30B	SS 30C	SS 40A
L (mm)	1.846	1.846	2.866	2.866	2.816	2.816	3.424	3.424
W (mm)	220	220	220	220	270	270	270	270
CTC (mm)	1.250	1.250	1.250	1.250	1.380	1.380	1.380	1.440
B (mm)	1.390	1.390	1.390	1.390	1.580	1.580	1.580	1.640

Model	SS 40B	SS 40C	SS 50A	SS 50B	SS 60A	SS 60B	SS 60C	SS 60D
L (mm)	3.424	3.424	3.424	3.424	4.592	4.592	5.826	5.826
W (mm)	270	270	270	270	320	320	320	320
CTC (mm)	1.440	1.440	1.500	1.500	1.135	1.135	1.135	1.135
B (mm)	1.640	1.640	1.840	1.840	1.975	1.975	1.975	1.975
T (kg)	6.500	6.600	7.700	7.800	11.300	11.600	12.900	13.400

Model	SS 70A	SS 70B	SS 80A	SS 80B	SS 80C	SS 80D
L (mm)	5.726	5.726	5.726	5.726	6.976	6.976
W (mm)	420	420	420	420	420	420
CTC (mm)	2.272	2.272	2.520	2.520	2.520	2.520
B (mm)	2.412	2.412	2.660	2.660	2.660	2.660
T (kg)	17.000	17.400	22.800	23.100	25.600	26.000

SS SERIES

Steam fired single effect absorption chillers

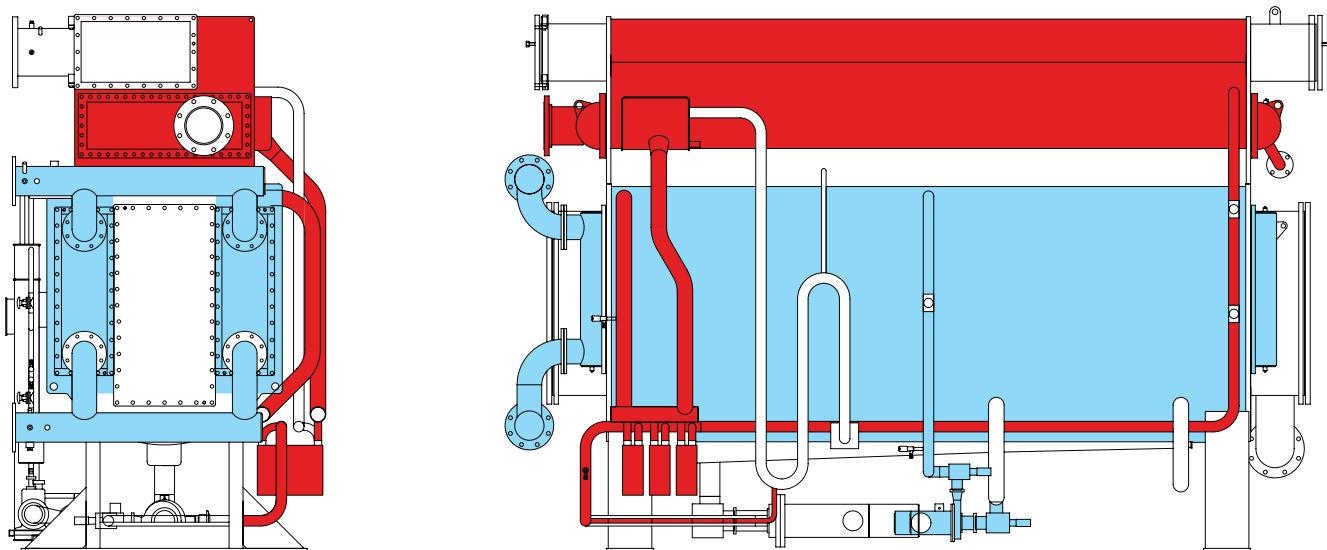

INSULATION







 19 mm thick insulation for hot surfaces (150°C max).

 25 mm thick insulation for cold surfaces (5°C min).

SURFACES TO BE INSULATED (in m²)

Model	SS 20A	SS 20B	SS 20C	SS 20D	SS 30A	SS 30B	SS 30C	SS 40A
	10,0	10,0	13,1	13,1	15,9	15,9	17,2	19,9
	14,3	14,3	16,2	16,2	19,1	19,1	20,4	25,6

Model	SS 40B	SS 40C	SS 50A	SS 50B	SS 60A	SS 60B	SS 60C	SS 60D
	19,9	19,9	22,4	22,4	31,2	31,2	34,9	34,9
	25,6	25,6	29,9	29,9	38,0	38,0	43,3	43,3

Model	SS 70A	SS 70B	SS 80A	SS 80B	SS 80C	SS 80D
	38,3	38,3	46,2	46,2	52,4	52,4
	48,7	48,7	55,2	55,2	60,8	60,8

SS SERIES

Steam fired single effect absorption chillers

PERFORMANCE CURVES

The following curves show the qualitative trend of the cooling capacity when some typical operative conditions are changed.

They provide a first tool to qualitatively estimate the effects of some changes in the working conditions

on the cooling capacity.

Anyway, for a more precise evaluation, it is recommended to ask to Thermax authorized offices for one or more machine selections based on the required working parameters.

Indications of below graphs are only indicative.

CAPACITY Vs CHILLED WATER OUTLET TEMPERATURE

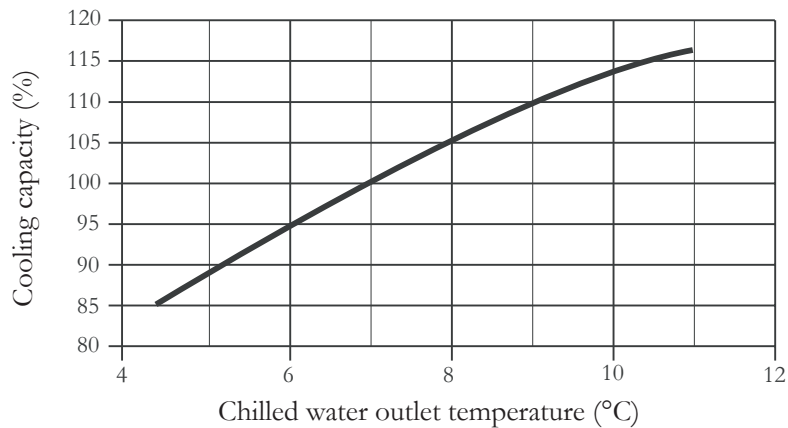

Cooling water inlet temperature: 29°C
Chilled water DT: 5°C

CAPACITY Vs CHILLED WATER TEMPERATURE DT

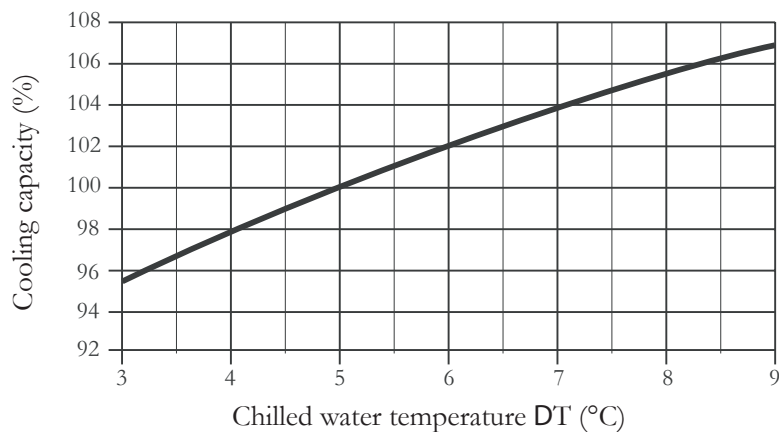

Cooling water inlet temperature: 29°C
Chilled water outlet temperature: 7°C

SS SERIES

Steam fired single effect absorption chillers

CAPACITY Vs COOLING WATER INLET TEMPERATURE

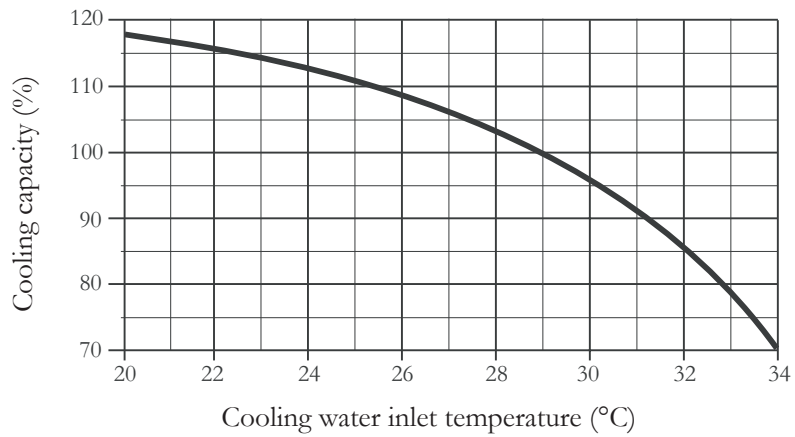

Chilled water outlet temperature: 7°C

Steam pressure: 150 kPa

CAPACITY Vs STEAM PRESSURE

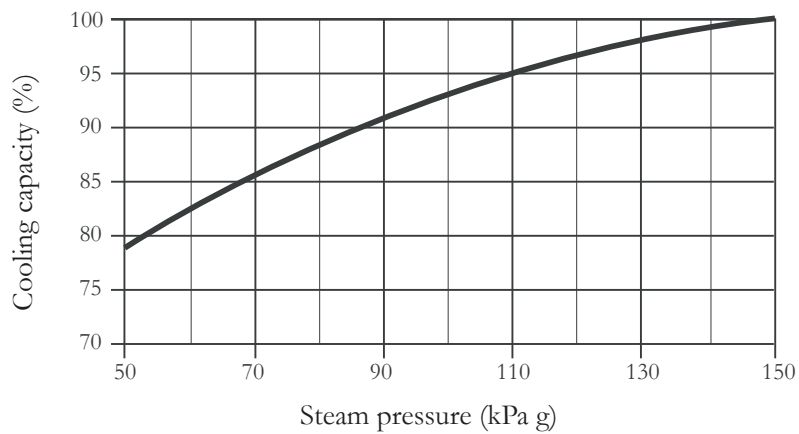

Chilled water outlet temperature: 7°C

Cooling water inlet temperature: 29°C

SS SERIES

Steam fired single effect absorption chillers

TYPICAL P&I DIAGRAM

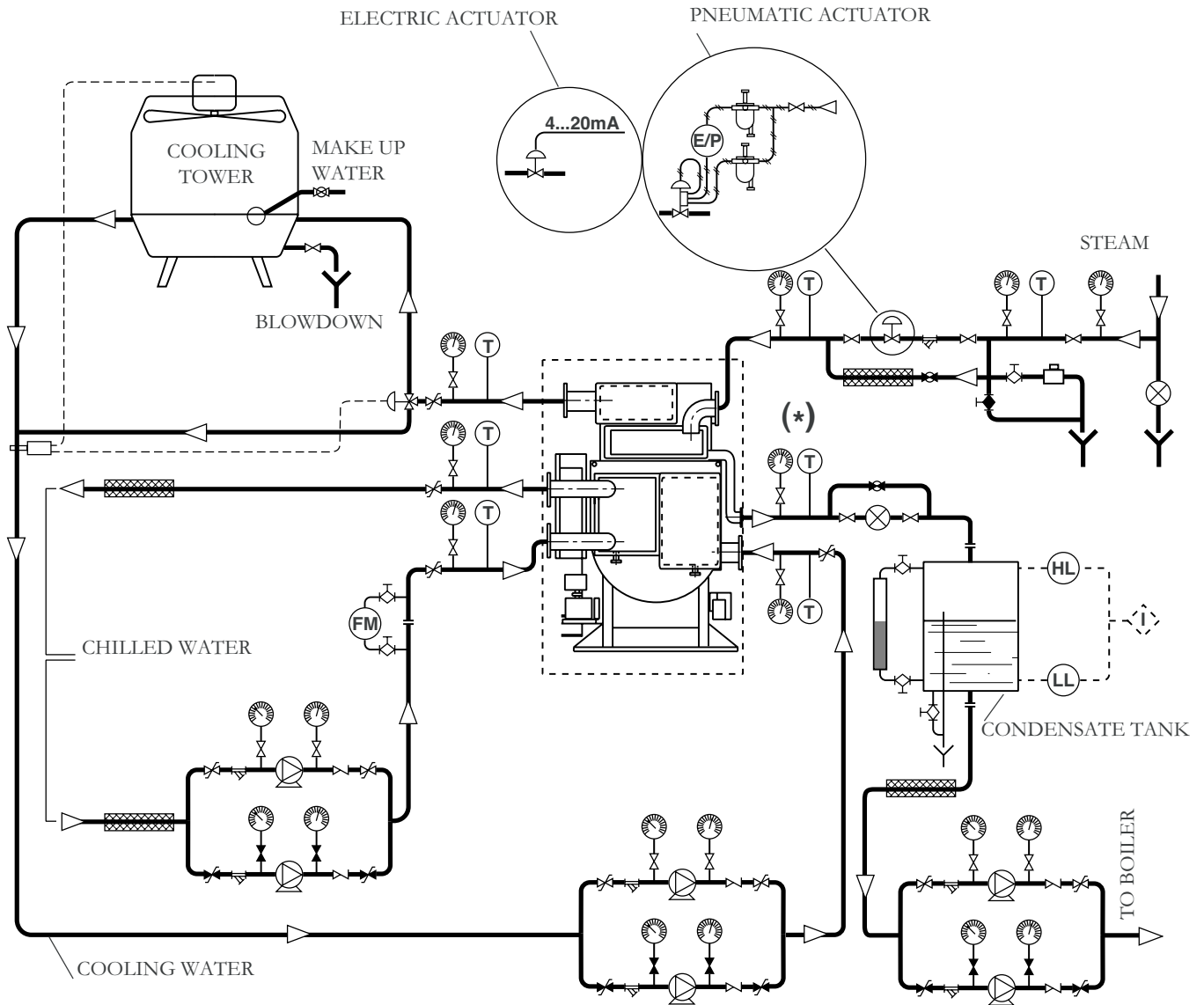

Device closed	Water pump	Level indicator
Device open	Thermostat	Thermodynamic steam trap
Butterfly valve	Thermometer	50mm insulation
Globe valve	Flowmeter	
Non return valve	Control valve	4...20mA Drive signal
"Y" strainer	Inverted bucket steam trap	Pneumatic line
Cock	High level switch	Air filter regulator
Manometer	Low level switch	E/P converter

(*): condensate drain pressure = 20 kPa



THERMAX

www.thermax-europe.com

THERMAX EUROPE LIMITED, 2 STUDIO COURT, QUEENSWAY, BLETCHLEY
MILTON KEYNES MK2 2DG, UNITED KINGDOM

Telephone: +44 1908 378914 Fax: +44 1908 379487

e-mail: info@thermax-europe.com

Technical data and dimensions are not binding. In view of our constant endeavour to improve the quality of products, we reserve the right to amend any product details and contents of this literature without prior notice.

TECH.SS.ENG.REV3-2015