



# **Liebert<sup>®</sup> AFC**

## **Adiabatic Freecooling Unit with Helical Compressor Backup**

User Manual

English, Cod. 265483MAN\_ENG, rev. C - 22.08.2022



## Caution



It is recommended that:

- the manual is retained for the entire service life of the machine;
- the user reads the manual carefully before carrying out any operations on the machine;
- the machine is used exclusively for the purpose for which it is intended; incorrect use of the machine shall release the manufacturer from any liability.

This manual has been prepared to enable the end- user to carry out only those operations that can be done with the panels closed.

Any operations that require the opening of doors or equipment panels must be carried out only by qualified personnel.

Each machine is equipped with an electric isolating device which allows the operator to work in conditions of safety. This device must always be used to eliminate risks during maintenance (electric shocks, scalds, automatic restarting, moving parts and remote control). The panel key supplied with the unit must be kept by the person responsible for maintenance.

For identification of the unit (model and serial no.) in case of the necessity for assistance or spare parts, read the identification labels affixed to the outside and inside of the unit.

“This manual, written in English, is the original version”.

**IMPORTANT:** This manual may be subject to modification; for complete and up to date information the user should always consult the manual supplied with the machine.

## Contents

<b>1 - Introduction</b> .....	<b>1</b>
1.1 - Foreword .....	1
1.2 - Responsibility .....	1
1.3 - General description .....	1
<b>2 - Preliminary Operations</b> .....	<b>1</b>
2.1 - Packing removal .....	1
2.2 - Inspection .....	1
2.3 - Operating limits .....	1
2.4 - Sound pressure levels .....	2
2.5 - Transport .....	2
2.6 - Foundations .....	2
2.7 - Service area .....	2
<b>3 - Installation</b> .....	<b>3</b>
3.1 - Hydraulic connections .....	3
3.2 - Connection of the safety valve discharge .....	5
3.3 - Electrical connections .....	5
<b>4 - Start-Up and Operation</b> .....	<b>9</b>
4.1 - Initial check .....	9
4.2 - First start-up (or after a long stop) .....	9
4.3 - Starting and stopping .....	9
4.4 - Unit serving special plant .....	10
4.5 - Freecooling .....	10
4.6 - Freecooling versions: Two-way valves .....	10
4.7 - Microprocessor control .....	10
4.8 - Variable Primary Flow with Liebert® AFC .....	10
<b>5 - Refrigerant and Oil Charge</b> .....	<b>14</b>
5.1 - Refrigerant charge .....	14
5.2 - Oil charge .....	15
<b>6 - Calibration</b> .....	<b>15</b>
6.1 - Electronic expansion valve .....	16
6.2 - Condensing control .....	16
6.3 - Environment protection .....	16
<b>7 - Maintenance</b> .....	<b>16</b>
7.1 - Coil cleaning procedures .....	17
7.2 - Compressor maintenance schedule - checks and tests .....	18
7.3 - Lubrication - pump .....	18
7.4 - Spare parts .....	18
7.5 - Dismantling the unit .....	18
7.6 - Regulation (EC) no. 517/2014 (F-gas) .....	20
<b>8 - Options and Accessories</b> .....	<b>23</b>
8.1 - Pumps Group .....	23
8.2 - Hydraulic kit .....	23
8.3 - Economiser .....	23
8.4 - Energy meter (optional) .....	24
8.5 - Water inlet manifolds .....	24
<b>9 - Electrical Panel and Unit Control</b> .....	<b>25</b>
9.1 - Double Power Supply, UltraCap and Fast Start Ramp .....	25
9.2 - Controls: indicative capacity/Efficiency data .....	27



# 1 - Introduction

## 1.1 - Foreword

The handbook and all the documents supplied with the system are aimed at enabling both the installer and the operator to carry out correctly installation, control and maintenance operations on the unit and System adiabatic if present, without damaging it or harming the relevant staff.

The handbook and the supplied documents are thus an aid for the skilled staff to arrange the special outfit so as to install, operate and maintain the machine correctly according to the local norms in force.

The handbooks, wiring diagrams and documents enclosed to the machine must be read and kept for the whole system life.

The **Liebert® AFC** air cooled units can be identified as follows:

### FA4 130

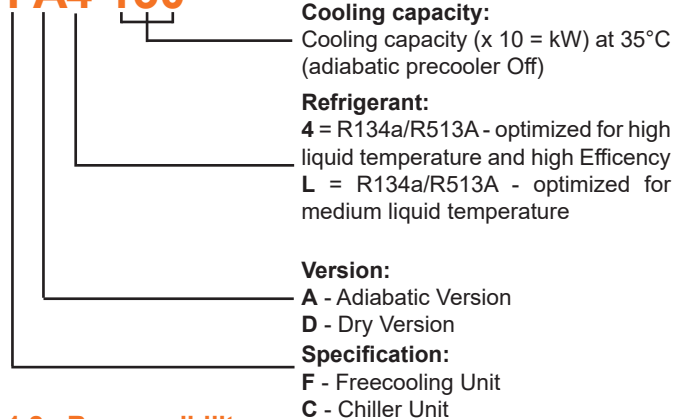

## 1.2 - Responsibility

Vertiv™ accepts no present or future responsibility for damage to persons, things or to the machine itself due to operators' negligence, failing to comply with the installation, operation and maintenance instructions of this handbook, failed application of the safety norms in force for the system and the qualified staff charged with the operation and maintenance

## 1.3 - General description

**Liebert® AFC** units with air-cooled condensers, have been designed and manufactured for producing chilled water.

They are available in versions with a built-in freecooling module and pump unit installed on the machine; the chilling units can be equipped with several options indicated in the price list. The **Liebert® AFC** product line has been designed considering the state-of-the-art techniques available nowadays in the industry, and includes all the components necessary for automatic and efficient operation. Each unit is completely factory assembled; after evacuation, the necessary quantity of refrigerant is added to the refrigerant circuits and the unit is tested. All of the units are equipped with two independent refrigerating circuits, each one composed of: an air-cooled condenser, a semi-hermetic Helical compressor, a tube Evaporator and lines. The components of the liquid line are the charging valves, the filter-dryers, the solenoid valve, the shut-off valve, the moisture indicator and the thermostatic expansion valve; a discharge line valve is installed on the compressor, while they are optional on the suction line. The hydraulic circuit is made up of grooved hydraulic lines connected by joints, a flow switch and, in the freecooling versions, chilled-water coils and a three-way valve. The semi-hermetic Helical Compressor are complete with the following protection/safety devices: oil heater, internal safety valve according to EN 60335-2-34, oil sight glass, electronic protection controlling the temperature of the motor windings, the oil temperature and the Helical rotating direction.

The **Liebert® AFC** water chillers are controlled by the "iCOM™" microprocessor, managing all of the unit operating conditions. The user can change and/or modify the operating parameters through the display keyboard installed on the electrical panel. The electrical control board is equipped with all the safety and operating devices needed for reliable automatic operation. The compressor motors are equipped with protection on all the three phases and are started by their three-pole contactors.

# 2 - Preliminary Operations

## 2.1 - Packing removal

Remove the polythene package caring not to damage the unit. Also remove the polythene from the System adiabatic packages. Dispose of the package materials delivering them to specialize collection or recycling centers (comply with the local norms in force).

## 2.2 - Inspection

All the units are assembled and wired in the producing factory. Before shipment they are charged with the necessary quantities of refrigerant and oil and then tested under the operating conditions required by the customer. The free-cooling coils are supplied dry to avoid possible problems due to the frost in the storage period. Immediately inspect the machine and the System adiabatic parts carefully on delivery to check for damage during transportation or missing components; possible claims must be made immediately to the carrier and the factory or its representative.

## 2.3 - Operating limits

Refer to the table "*Tab. 3 - Operating range*" showing the limits for each model; contact your dealer for different values.

### 2.3.1 - Outer air temperature

The units are designed to operate at:

- Min. temperatures:
  - 25 °C for the freecooling models
  - 10 °C for the chiller models
- Max. temperatures:
  - depending on the model as indicated in the table "*Tab. 3 - Operating range*".

System adiabatic could work without any water freeze problem till 10°C; below that limit freezing risk is quite high so it's recommended to stop and empty the whole System adiabatic. More info in *chapter 2* of Adiabatic Cooling system integration user manual.

Such limits are considered for new machines or machines that have been correctly installed and maintained.

The units are designed to be stored at:

- Temperatures: + 0 °C / + 45 °C, Ask your Vertiv™ representative for T < 0°C
- Humidity: 80 % R.H., not condensing

### 2.3.2 - Water circuit

The water delivery is indicated in the table "*Tab. 3 - Operating range*". Higher delivery values can cause corrosion and vibrations inside the tube nest heat exchanger. The min. allowed water delivery corresponds to a max. thermal change of about 8°C. Tougher operating conditions can activate the safety devices locking the unit.

For FA4 models (with System adiabatic) the max outdoor temperature is to be understood as dry bulb temperature after PAD (System adiabatic); the real relevant dry bulb ambient temperature before PAD could be calculated by the table *Tab.1 - System adiabatic performance of "Adiabatic Cooling system integration"* User Manual, according the outdoor R.H. %.

For FD4 with LN option units, outlet water temperature higher than 15 °C must be carefully checked together with max ambient limits. The outlet water temperature must range from 4°C to 25°C for all the other **AFC** versions.

The maximum allowed water return temperature, when the unit is in full operation, is 32°C; return temperatures over 32°C are allowed only during start-up. The max. allowed glycol percentage is 50 % (35 % with pump units). The min. glycol percentage needed depends on the min. room air temperatures in the installation place.

The max. hydraulic operating pressure is 10 barg: take care that this limit is independent of presence / absence of pumps fitted on the unit, so it's necessary to check the max. pump static head (indicated on pump's name plate) and pressurized the water circuit never more than 10 barg minus max. pump static head.

**NOTE:** Safety valve is set at 6 barg, optional.

### 2.3.3 - Power supply

Electrical panel designed according to CEI EN 60204-1 "Safety of machinery - Electrical equipment of machines".

- Voltage: in standard operating conditions, from 0.9 to 1.1 times the rated voltage.
- Frequency: from 0.99 to 1.01 times the rated frequency continuously.
- Voltage unbalance: must be lower than 2%.

The Fig. a shows a calculation example of the voltage unbalance.

**Fig. a - Example of calculating phase to phase variability**

- 1) The 400 V supply has the following variability:  
RS = 388 V  
ST = 401 V  
RT = 402 V
- 2) The average voltage is:  
$$\frac{388 + 401 + 402}{3} = 397$$
- 3) The maximum deviation from the average is:  
402 - 397 = 5 V
- 4) The phase to phase variability is:  
$$\frac{5}{397 \times 100} = 1.26 \text{ (acceptable)}$$

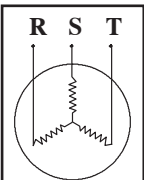

### Three-phase electric power

#### Requirements:

Liebert® AFC units are equipped with electrical devices (EC motors, power supplies module, inverter pumps, control devices, etc.) that are designed to operate properly with Star-connected power (Wye) with earthed neutral (TN or TT system).

Three-phase distribution Delta-connected (Δ) or Star-connected power (Wye) without ground or floating ground (IT) contact **Vertiv**™. Wye (Y) vs. Delta (Δ) power supply connection diagram.

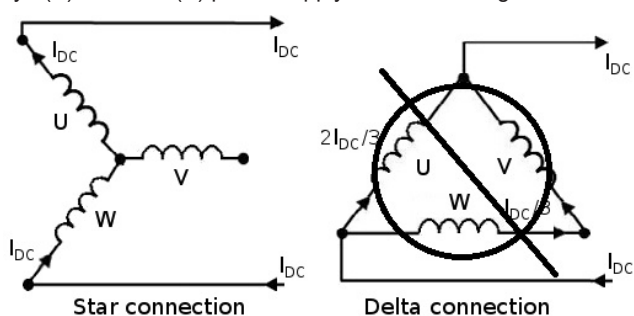

#### Acceptable power supply (TT, TN-S, TN-C, TN-C-S systems):

- 400V Wye with solidly grounded neutral (230V line to ground).

#### Unacceptable power supply:

- 400 V Wye without ground connection or with high-resistance (or impedance) ground (IT).
- 400 V Δ without ground or with high-resistance (or impedance) ground (IT).
- 400 V Δ with corner ground or with grounded center-tapped.

### 2.4 - Sound pressure levels

Tab. 5 - "Sound pressure levels" shows the noise data for the units in standard configuration (without pumps) with and without PAD, operating continuously and measured according to the ISO 3744 norm, in free field conditions.

The highest noise levels are detected on the coil side.

**NOTE:** Avoid positioning in areas with possible reverberation of the sound waves, which can adversely effect the noise levels.

### 2.5 - Transport

- If the unit is shipped with a container, for extracting, follow the instructions placed on the front panel;
- Handle the unit by lifting it with a crane from above;
- The lifting holes are positioned in the frame's base (when lifting use spreader bars to protect the side, see Fig.3 to Fig.6).

#### N.B:

Place the lifting tubes (optional) in the holes in the base indicated with "LIFT HERE". Lock the ends of the tubes in position with the ring nut, as shown in Fig. 3, using 60 mm span. The capacity of the lifting gear must be adequate to lift the load in question. Check the weight of the units, the capacity of the lifting gear and ropes and the condition and suitability of the aforementioned equipment.

- Part of the System adiabatic equipment is separately shipped and packaged with pallet. Use a forklift to handle it.

### 2.6 - Foundations

- The unit must be placed on a level surface which will support its weight.
- If necessary, position the unit on suitable anti-vibration supports (see Fig. 7) that can be supplied as an option (in rubber or spring-type).



#### NOTICE

- Position the anti-vibration supports on the ground, lower the unit on them and at the end fix the anti-vibration supports to the unit itself.
- Refer to the manual "Installation of the spring anti-vibration supports" for their correct positioning.
- When positioned, level the unit and bolt it to the floor.



#### NOTICE

For weight distribution see Fig. 8 Support positions and loads.



#### WARNING

The Weight and their distribution refer to standard units with and without pumps or other options are installed on the machine, add the weight of the installed accessories to those of the standard units.

### 2.7 - Service area

- In order to allow free air flow and maintenance of the unit, a minimum area must be left free of obstructions around the unit (see Fig. 1 Service areas).
- The hot air expelled by the Fans must be allowed to rise unimpeded by obstacles for a minimum Height of 2.5m.
- Avoid recirculation of hot air between suction and delivery,

otherwise the unit performance may be impaired or the standard operation can be interrupted.

## 3 - Installation

### 3.1 - Hydraulic connections

#### 3.1.1 - Hydraulic circuit construction (Fig. b)

The piping must be connected to the unit as shown in Fig. b.

Construct a chilled water circuit as described below, see Fig. b:

1. Place shut-OFF valves within the circuit to allow servicing.
2. Install a pump system calculated for the flow rate required at a pressure head equal to the sum of all the pressure drops (see project data). The refrigerating units can be equipped, upon request, with pumps having delivery and head as indicated in diagram.
3. Install manometers at the unit inlet/outlet.
4. Install thermometers at the unit inlet/outlet.
5. Connect the pipes to the unit by flexible joints to avoid transmitting vibrations and to balance the thermal expansion; proceed in the same way as with the pump assembly outside the unit.
6. It is useful to include a water pressures witch to give an early warning of low water pressure.

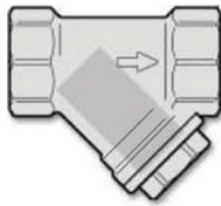

7. Place a mesh filter at the inlets of the pump and water unit (can be supplied as an optional accessory - Not fitted). The filter must be installed in the hydraulic circuit using the pipes and joints of the kit. At the end of this manual there is the data sheet.

If the fluid contains particles larger than 1 mm (0,04 inch), we recommend that a strainer with a size of 16 - 20 mesh (liczba openings per inch) is installed before the exchanger. The particles could otherwise block the channels, causing bad performance, increased pressure drop and risk of freezing.

8. Install, at the highest points in the circuit, apparatus which allows the bleeding of air and also the filling of glycol.
9. Place a drain valve at the lowest points in the circuit.
10. Install a water fill group including the following:
  - a. filling meter;
  - b. manometer
  - c. non return valve
  - d. air separator
  - e. removable supply tube, which **must be disconnected after each charge/topping up.**
11. For maximum protection ensure that all tubing exposed to low outdoor temperatures is fitted with anti-freeze heaters and insulated using closed cell synthetic rubber (elastomer).
12. The circuit must include an expansion tank (with safety valve) with suitable capacity.



#### CAUTION

If the water unit is complete with the expansion tank (supplied as an option), check if the capacity is enough or possibly install a second tank in the circuit (see par. 8.2). Follow the indications in Fig. d for the correct sizing.



#### NOTICE

The whole circuit must contain a water volume suitable for the capacity of the installed refrigerating unit. Check if the inertial capacity given by the sum of the hydraulic volume inside the machine and the system volume is sufficient, or possibly install a tank in the circuit. Follow the indications in Fig. c for the correct sizing.



#### NOTICE

In case of unit with fix flow option, the hydraulic circuit must ensure a constant water delivery to the Evaporator in every operating condition. Otherwise, the Compressor can break due to repeated returns of liquid refrigerant on their suction.



#### NOTICE

Do not install on the water outlet motorized shut-OFF valves configured as normally closed in stand-by status, because of the presence of check valves inside chiller on pump delivery. On the contrary, it is possible to install these motorized valves on the water inlets.

#### 3.1.2 - Additional of water and ethylene glycol

##### Very Important:

Add water and ethylene glycol in the circuit with a % depending on the min. temperature of the outside air expected in the installation site. Do not exceed the nominal operating pressure of the circuit's components.



#### NOTICE

- To avoid stratification run the circulation pump for at least **30 mins.** after adding any glycol. If the pumps are fitted on the unit, they have to be run all together.
- Water glycol fluid mixture has to be circulated inside the unit hydraulic parts including Freecooling coils and by-pass pipes; in order to do it move the two 2-way valves on both positions for the time necessary.
- After adding water to the hydraulic circuit **always disconnected the water supply coming from the sanitary circuit**; this avoids the danger of glycol entering the sanitary water circuit.
- After any topping-up of water check the concentration and add glycol if necessary.

#### 3.1.3 - Water- glycol mixture

Water-glycol mixtures are used as the thermal carrier fluid in very cold climates or with temperatures below zero degrees centigrade. Determine the % ethylene glycol which must be added to the water, with the assistance of Tab. a.

**Tab. a - Ethylene glycol to be added to water (% in weight of total mixture)**

Ethylene glycol (% in weight)	0	10	20	30	40	50
Freezing temperature, °C(*)	0	-4.4	-9.9	-16.6	-25.2	-37.2
Mixture density at 20 °C (*), kg/l	-	1.017	1.033	1.048	1.064	1.080

(\*) Values are for Clariant Antifrogen N. For different brands, check manufacturer's data.

For the water charges in the circuit refer to the Tab. 2 - Internal hydraulic volume.



**NOTICE**

ALWAYS CHARGE THE HYDRAULIC CIRCUIT WITH THE REQUIRED GLYCOL % NECESSARY FOR THE MIN. AMBIENT TEMPERATURE OF THE INSTALLATION SITE, FAILING TO COMPLY WITH THIS INSTRUCTION SHALL INVALIDATE THE UNIT WARRANTY.

**3.1.4 - Protection and cleaning of the Evaporator and components of hydraulic circuit**

It is the user's responsibility to establish the quality of the water and make sure that this is compatible with the materials used in the hydraulic components and exchangers. The quality of water may significantly affect the operation and the life of the exchangers. The first step in the planning the treatment of the water is chemical analysis, which must be performed by qualified personnel from specialist organizations. Exchangers cleaning may be performed only with chemical method, using commercially - available products with a dual action, that is, the removal of the scale and the prevention of corrosion. In the chiller with pumps and in all freecooling units, water quality has to be in accordance with VDI 2035.

In tower water, the tendency to form deposits may be high: to reduce this phenomenon, there are various types of water softening treatments available, including the use of ion exchange resins. The oxygen dissolved in water increases the rate of corrosion. The main factors causing corrosion are sulphur and carbon dioxide acids (see the Langelier and Ryznar indices). A combined effect of fouling due to dust and organic material provides a support for bacteria, fungi and algae; the growth of organisms may produce an oxygen gradient and this results in rather severe pitting of the metallic surface. The phenomenon of corrosion is obviously related

to the material used on the liquid side of the heat exchanger. The following table shows the reference values for corrosion on Copper, these values must be considered as guidelines to avoid corrosion. In winter, if the system is stopped, the water inside the exchangers can freeze damaging the system irreparably; thus, it is recommended to use glycol mixtures (see following paragraphs: please consider the different outputs and absorption by the chiller, the pump sizing and the performance of the system terminals/conditioners) or drain the system completely, using the suitable cocks arranged in the exchangers and in the circuit, trying to drain the water residues blowing air in the lines.

**Tab. b - Water component for corrosion limit on Copper**

pH	-	7.5 ÷ 9.0
SO <sub>4</sub>	ppm	< 100
HCO <sub>3</sub> / SO <sub>4</sub>	-	> 10
Total hardness	dH	4.5 ÷ 8.5
CJ-	ppm	< 50
PO <sub>4</sub> <sup>3-</sup>	ppm	< 2.0
NH <sub>3</sub>	ppm	< 0.5
Free Chlorine	ppm	< 0.5
Fe <sup>3+</sup>	ppm	< 0.5
Mn <sup>++</sup>	ppm	< 0.05
CO <sub>2</sub>	ppm	< 50
H <sub>2</sub> S	ppb	< 50
Temperature	°C	< 65
Oxygen content	ppm	< 0.1

**Fig. b - Ideal chilled water circuit**

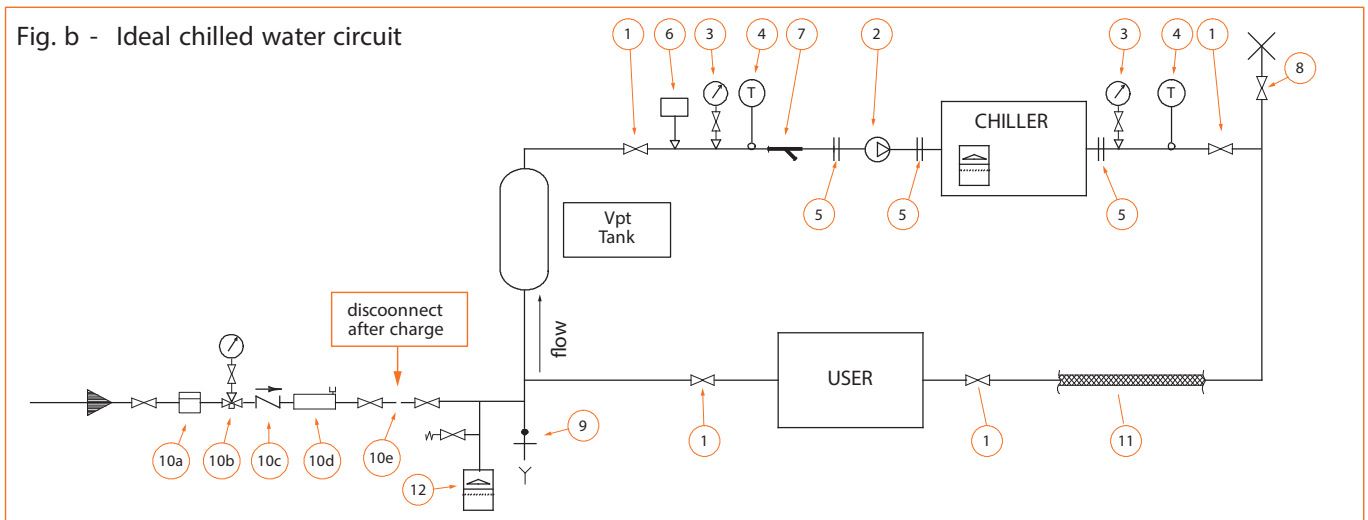

**Fig. c - Inertial tank sizing**

The total optimal hydraulic volume of the system where the **Liebert® AFC** unit is installed can be calculated by the following ratio:

$$V = \frac{43 \times R_t}{X_d}$$

where:

- **V** = min. required total water volume expressed in liters
- **R<sub>t</sub>** = refrigerating capacity expressed in kW
- **X<sub>d</sub>** = differential band set on the control and expressed in degrees centigrade

Please note that the min. required total water volume (V) must be at least equal to the sum of the hydraulic volume of the **Liebert® AFC** unit (V<sub>m</sub>) plus the volume of the hydraulic circuit connected to it (V<sub>pc</sub>); if this condition is not complied with, it is necessary to install an inertial tank (V<sub>pt</sub>, as indicated in the *Fig. b ideal chilled water circuit*) with a volume at least equal to the following value: V<sub>pt</sub>=V- V<sub>m</sub>- V<sub>pc</sub>

**Fig. d - Sizing of the expansion tank**

The total volume of the expansion tank is calculated with the following ratio:

$$V = \frac{C \times e}{1 - \frac{P_i}{P_f}}$$

where:

- **C** = quantity of water inside the system expressed in liters
- **e** = water expansion coefficient, with water at 10°C as a reference
- **P<sub>i</sub>** = absolute pressure of initial charging, equivalent to the tank pre-charge pressure (typical value 2.5 bara)
- **P<sub>f</sub>** = absolute final tolerated pressure, lower than the operating pressure or than the safety valve calibration pressure (typical value 4.0 bara).

Use the values of the water expansion coefficient indicated in the table below:

T [°C]	Density [kg/m³]	Expansion coefficient "e" H <sub>2</sub> O	"e" 10% glycol	"e" 20% glycol	"e" 30% glycol	"e" 40% glycol	"e" 50% glycol
10	999,6	0,001	0,003	0,005	0,007	0,013	0,015
20	997,9	0,002	0,005	0,008	0,010	0,015	0,018
30	995,6	0,004	0,007	0,011	0,013	0,017	0,020
40	992,2	0,008	0,011	0,014	0,016	0,021	0,024
50	988,1	0,012	0,015	0,018	0,021	0,025	0,028

### 3.2 - Connection of the safety valve discharge

On the refrigerating circuit safety valves are installed on the high and low pressure sides: the discharge of these valves must be conveyed outside through a suitable pipe, having a diameter of at least that of the valve discharge, without burdening the valve body; convey the discharge to areas where the jet cannot harm people.

### 3.3 - Electrical connections

1. Before wiring, check that:
  - the electrical components are in good conditions;
  - all terminal Helicals are well tightened;
  - the supply voltage and frequency comply with those indicated on the unit and within the tolerances indicated in the paragraph "Operating limits";
  - the max. unbalance between the phases does not exceed the value indicated in the paragraph "Operating limits".
2. Connection of the supply cable:  
The units are equipped with electrical panel with one main switch for the power section and one switch (option) for the control section.  
Choose a supply cable (three-pole type with ground) for the power section and a supply cable (two-pole type with ground) for the control section (option):
  - the local norms;
  - the system absorption (FLA unit);
  - the system voltage;
  - installation type;
  - cable length;
  - upstream protection.

After opening the passage in the structural works (precut), for

the supply line inlet, restore the original protection degree with suitable accessories for the wiring and junction boxes. Install the cable avoiding carefully to touch the hot parts. Connect the cable to the inlet terminal board (disconnecting switch terminals for phases, ground bar for PE conductor). After having connected the cable, restore the protections against direct contacts.

3. The system/line cable protection is to be arranged by the customer.  
Use a protection with differential switch. If the system is equipped with EC typ Fans and/or pumps with inverters, use a B typ switch.
4. Ethernet cable connection.  
The control can be connected with a remote display through an Ethernet network cable (see HW user handbook).
  - Fasten the cable to the clamp-holding plates and make it pass through the first free hole on the panel bottom (arrange a cable clamp).
  - After opening the passage in the structural works (precut), opposite the supply line inlet, restore the original protection degree with suitable accessories for the wiring and junction boxes.
  - The cable must be protected by a sheath.
5. Connection of the clean contacts for the unit status signals.  
The clean contacts can be used only with PELV typ sources, as described by the norm CEI EN 60204-1 "Safety of machinery - Electrical equipment of machines".  
The table below shows the available terminals and their meaning (refer to the wiring diagrams for further information).  
The cable passage must be arranged as described in the previous *point 4*).

**Contatti puliti a disposizione - Free contacts available**

400	<b>Allarme generale - Alim. B off</b> <b>General Alarm - Supply B off</b>	→ 400-401 NC
401		
402		
300	<b>Avviso - Alim. B off</b> <b>Warning - Supply B off</b>	→ 300-301 NC
301		
302		
450	<b>Compressore 1 in funzione</b> <b>Compressor 1 ON</b>	→ 450-451 NC
451		
452	<b>Compressore 2 in funzione</b> <b>Compressor 2 ON</b>	→ 452-453 NC
453		
462	<b>Pompa 1 in funzione</b> <b>Pump 1 ON</b>	→ 462-463 NC
463		
464	<b>Pompa 2 in funzione</b> <b>Pump 2 ON</b>	→ 464-465 NC
465		

**NOTE:**

The power supply should never be disconnected, except when performing maintenance.

Operate (open) the main switch before carrying out any maintenance work on electrical components.

**NOTE:**

It is forbidden to work on the electrical components without using insulating platforms, and in the presence of water or fog or mist.

**NOTE:**

The supply to the external pump assembly must be made before starting the chiller and must be kept on as long as the chiller is in use. Incorrect operation will cause the unit to lock-out because of the internal protections (flow switch intervention).

**NOTE:**

The Compressor are equipped with an electronic protection device blocking their start if the phase sequence is not correct, or stopping their operation if a thermal relay intervenes. This device is essential for the integrity of the mechanical and electrical components of the Compressor. Reset the standard functions by isolating this device and removing the causes of the lock-out.

**NOTE:**

The chillers are equipped with their own microprocessor control adjustment. The use of there mote ON-OFF input (located in the electric panel terminal board) as a system temperature control element is forbidden.

**Contatti in ingresso - Input contact**

470	<b>On-off remoto</b> <b>Remote on-off</b>	Supply voltage 24V AC
471		
472	<b>Ingresso utente</b> <b>User Input</b>	Supply voltage 24V AC
473		
482	<b>Blocca condensatori PFC</b> <b>Stop PFC</b>	Supply voltage 24V AC
483		

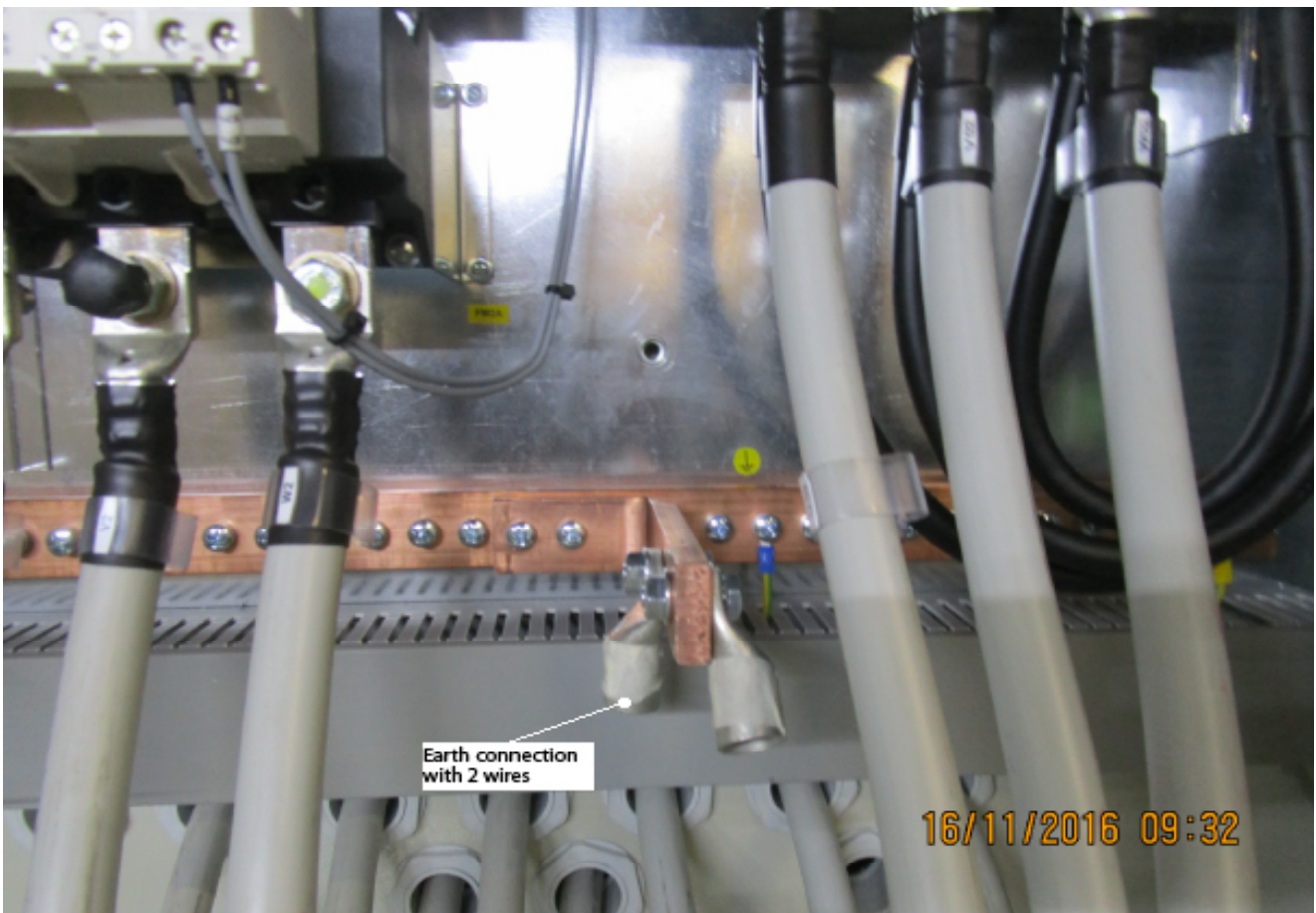
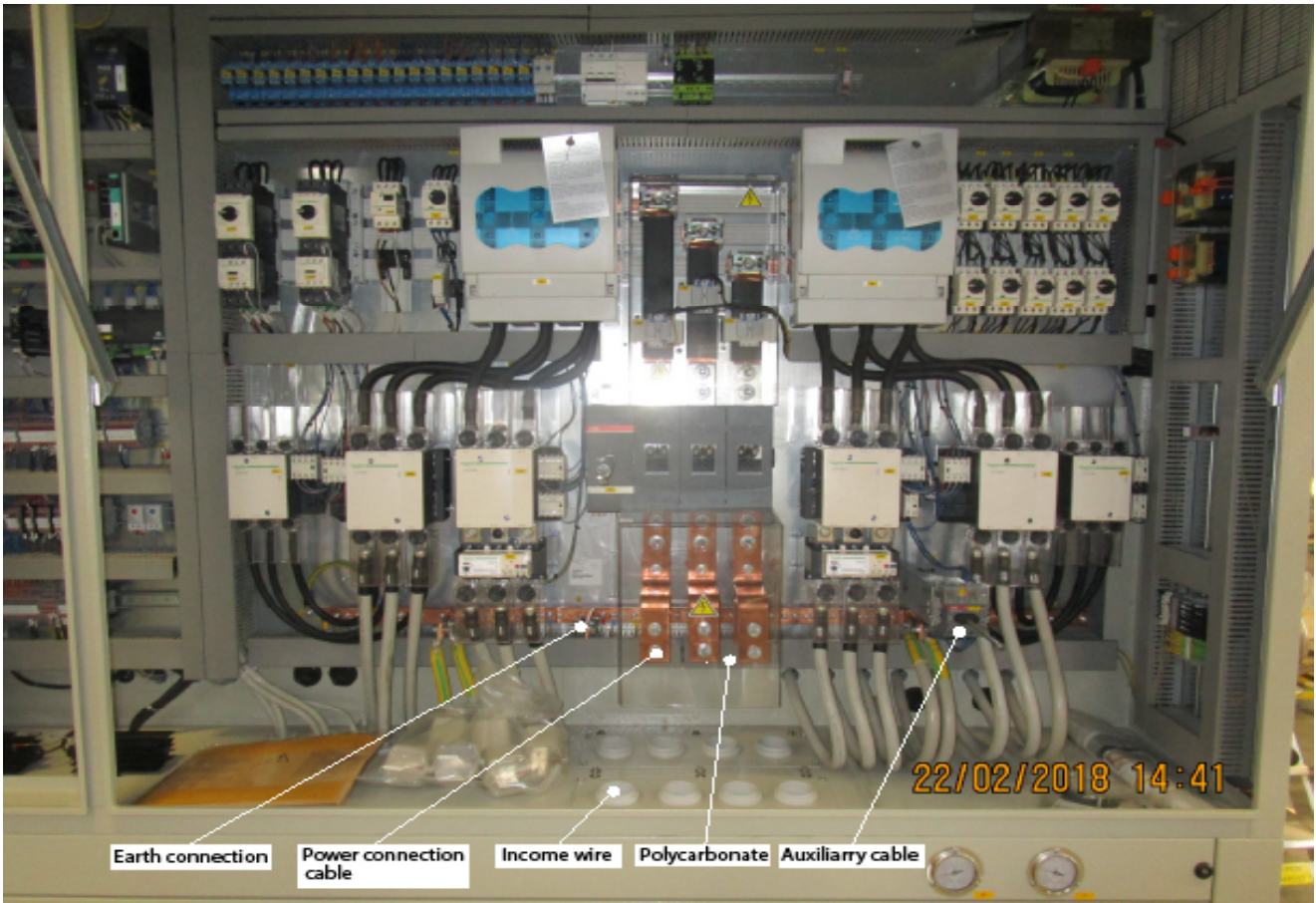

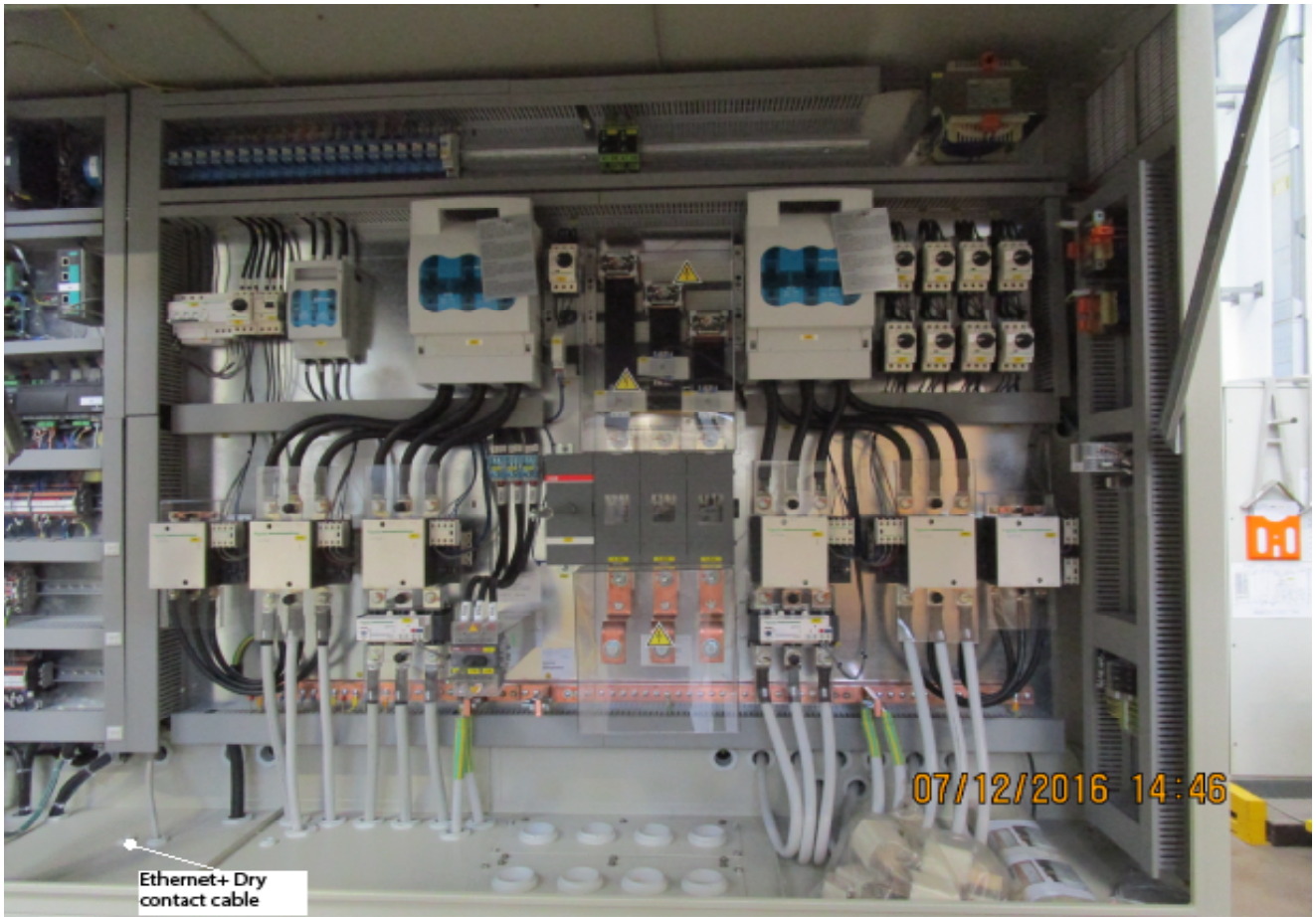

## 4 - Start-Up and Operation

### 4.1 - Initial check



#### CAUTION

The operation has to be done by a qualified technician with an experience and know-how on units, System adiabatics, iCOM™ control board and software.

Before the checks below make sure the unit power supply line is disconnected at the start. Make sure the disconnection device is locked and the suitable warning plate for no operation is applied on the start handle. Before operating on the electrical connections, make sure there is no voltage through a voltmeter or a phase detector.

Some components (electronic pumps, Fans EC, compressor's capacitors, soft-start, inverter) may remain high voltage for a short period after power supply removal. Wait at least **5** minutes to remove their electrical box panels and access to their parts under tension. Check all the cable connections particularly the main power connections on the power fuses, contactors and MCB.

1. Check that all thermal protections are calibrated according the electrical data tables reported on wiring diagram.
2. Check all Water connections.
3. Open the discharge valve (and the suction valve, if installed) of the compressor and the shut-off valve on the liquid line.
4. Ensure that the intake pressure is higher than 7.0 bar for R134a/R513A: if this is not the case, prolong pre-heating of the compressor (see *Fig. 10 - Refrigerant circuits*) and check that the refrigerant EEV valve (shut-off valve) is properly sealed.
5. Open all isolating valves and/or water ball valve
6. In case of climates with temperatures below zero degrees C°, make sure the chilled water circuit is filled with the correct concentration of water/glycol.
7. Bleed all air out of the chilled water circuit.
8. Verify the water flow rate and its direction.
9. Ensure that the thermal load is sufficient for Start-up.
10. Record the functional data on the Start-up certificate.



#### CAUTION

The outer air temperature probe must be positioned in the shade and protected against the weather.



#### CAUTION

Now set the handle of the door-lock general knife switch to the position "I"; it is now possible to supply the unit electrically closing the disconnection device upstream the power supply line.

### 4.2 - First start-up (or after a long stop)



#### CAUTION

**Liebert® AFC** is equipped with a cock on the liquid line downstream of the refrigerant filter, to be used exclusively to remove the cartridges during maintenance operations. The cock must always remain open, during transport and storage too.



#### NOTICE

At first Start-up is recommended to replace the cartridge of the driers. The used cartridge are hazardous waste and must to be disposed according with the local norms in force.



#### CAUTION

The manual cocks on the liquid line and the injection circuit of each refrigerating circuit must be kept closed during the dry run on the components (e.g. Compressor, valves/solenoid valves, EEV, etc.), see *fig. 10 – Refrigeration circuit*.



#### CAUTION

Before the following operations, make sure all protections on the units have been reset; set the handle of the door-lock general knife switch to the position "I", check of the display LED switched on and check again by a voltmeter or tester if the voltage and phase difference fall within the indicated limits.

Operate as follows:

1. **At least 8 hours before the start-up, power the crankcase heaters by setting the operating knife switch ON. Make sure the auxiliary circuit has been powered and check the operation (a fault due to an incorrect procedure will invalidate the compressor guarantee).**
2. Open the valves of the refrigerating circuit that had been closed before the initial check.
3. Check the machinery supplying the thermal load connected with the unit and start the system pump/s.
4. **MAKE SURE THE COMPRESSOR OIL HAS BEEN HEATED FOR AT LEAST 8 HOURS;** start the unit only then.
5. Make sure the Fans rotate in the correct direction (counterclockwise): check the electrical connections, if necessary.
6. Make sure the pumps rotate in the correct direction.
7. **During the unit start-up temperature of the water/glycol inlet higher than 32°C is allowed. Under standard operating conditions check that the limits indicated in *paragraph 2.3* are not exceeded.**
8. Check the correct operation of the control and safety devices.
9. Check the outlet temperature of the chilled water (check if the set-point set on the control is reached).
10. Check the compressor oil level.
11. With the compressor at full load, check there are no bubbles visible in the flow indicator. If there are any, charge the unit according to *par. 5*.



#### WARNING

Info about System adiabatic start-up is present in *Chap. 3* and *4* of "Adiabatic Cooling System Integration" User Manual.

### 4.3 - Starting and stopping



#### NOTICE

**ALWAYS ENSURE THAT THE COMPRESSOR OIL HAS BEEN PREHEATED. FOR BRIEF STOPPAGES MAINTAIN THE SUPPLY TO THE CRANKCASE HEATER.**

- **Start** the unit setting the Microprocessor switch **ON**.
- **Stop** the unit setting the Microprocessor switch **OFF**.
- In case of long stops, cut the machine **OFF** setting the Microprocessor switch **OFF**.  
In this case the compressor crankcase heaters remain powered.
- For seasonal shutdown of the unit operate the main switch located on the main electrical power supply. This will disconnect the compressor crankcase heaters. Machine restart must be managed as in § 4.2 "First startup (or following a long interruption)". Expiry of a time limit is indicated by a (non-blocking)

- message to inform the user about the event. The user must clear the message.
- The unit can tolerate short periods without power due to a blackout without the fast start function (up to four hours), with automatic restart without the need to repeat the procedure described in § 4.2 "First startup (or following a long interruption)". Expiry of a time limit is indicated by a message to inform the user about the event. The user must clear the message.
- The unit can tolerate short periods without power due to a blackout with the fast start function (up to one hour), with automatic restart without the need to repeat the procedure described in § 4.2 "First startup (or following a long interruption)". Expiry of a time limit is indicated by a message to inform the user about the event. The user must clear the message.

#### 4.4 - Unit serving special plant

The units are capable of cooling a water-glycol mixture to temperatures close to 0 °C without the need for significant modifications. In the case of modification, the set values of the safety and control components must also be modified. This can be carried out in the factory (at the time of testing) or at the time of installation, only by qualified and authorized personnel.

#### 4.5 - Freecooling

The freecooling is a system of pre-cooling and/or cooling the water/glycol mixture using ambient air ("free-cooling") when the latter is at a temperature below the return mixture temperature. If the outside temperature is sufficiently low to dissipate the entire heat load, the refrigeration Compressor automatically switch off, and the mixture's temperature is controlled by the fan speed adjustment.

If the mixture temperature is too high for freecooling, the Compressor will operate as long as necessary to ensure the correct water/glycol mixture temperature.

#### 4.6 - Freecooling versions: Two-way valves



The freecooling hydraulic circuit comprises two 2-way motorised valves operating oppositely: when one is open, the other is closed. Actuator running time (90° angle rotation) is **150** seconds.

#### 4.7 - Microprocessor control

Consult the "iCOM™" Service Manual.

#### 4.8 - Variable Primary Flow with Liebert® AFC

Variable water flow involves changing the water flow through the chiller as the load changes with direct ratio. Liebert® AFC units with variable flow option are designed for this duty provided that the water flow variations are within defined limits minimum flow, maximum flow and maximum flow variation speed.

The recommended maximum change in water flow is 10 percent of the nominal flow per minute. This specified limit is valid if there is the recommended inertial water volume at the hydraulic chiller inlet connection. Overcoming this limit could affect EEV control and Compressor reliability.

Flow rates below the minimum values can result in laminar flow through the exchangers causing freeze-up problems, scaling, Efficiency drop down and poor control. Flow rates above the maximum values will result in unacceptable pressure drops and can cause excessive erosion, potentially leading to failure.

In the evaluation of the minimum flow rate associated with each model must be evaluated carefully the required accuracy on the chiller's leaving water temperature (LWT)

Unit controller manages the minimum and maximum limits of flow rate as well as its fluctuations; if the unit is working next to indicated limits, warning and then alarm are generated with a different strategy according the presence of inverter pump installed on the unit or not.

### Minimum and Maximum flow limits for each model

AFC Model (#)	Nominal fluid flow [m³/h]	Min fluid flow [m³/h]	Max fluid flow* [m³/h]
FA4 088 (26-20)	157,4	80	175
FA4 102 (26-20)	178,6	95	214
FA4 117 (26-20)	205,6	110	227
FA4 130 (26-20)	233,1	125	234
FA4 10X (26-20)	178,6	95	190
FA4 145 (26-20)	261,3	125	302
FA4 160 (26-20)	277,1	125	331
FA4 088 (15-10)	133,3	80	175
FA4 102 (15-10)	151,7	95	214
FA4 117 (15-10)	174,8	110	227
FA4 130 (15-10)	198,2	125	234
FA4 10X (15-10)	151,7	95	190
FA4 145 (15-10)	223,4	125	302
FA4 160 (15-10)	237	125	331
FD4 088 (26-20)	158,7	80	175
FD4 102 (26-20)	180	95	214
FD4 117 (26-20)	207,3	110	227
FD4 130 (26-20)	234,9	125	234
FD4 10X (26-20)	180	95	190
FD4 145 (26-20)	263,7	125	302
FD4 160 (26-20)	279,9	125	331
FD4 088 (15-10)	134,1	80	175
FD4 102 (15-10)	142,7	95	214
FD4 117 (15-10)	176,3	110	227
FD4 130 (15-10)	199,4	125	234
FD4 10X (15-10)	142,7	95	190
FD4 145 (15-10)	224,9	125	302
FD4 160 (15-10)	238,9	125	331
FA4 088 LN (26-20)	150,4	80	175
FA4 102 LN (26-20)	170,4	95	214
FA4 117 LN (26-20)	196,3	110	227
FA4 130 LN (26-20)	222,8	125	234
FA4 10X LN (26-20)	170,4	95	190
FA4 145 LN (26-20)	247,8	125	302
FA4 160 LN (26-20)	261	125	331
FA4 088 LN (15-10)	128,6	80	175
FA4 102 LN (15-10)	146,4	95	214
FA4 117 LN (15-10)	168,5	110	227
FA4 130 LN (15-10)	191,4	125	234
FA4 10X LN (15-10)	146,4	95	190
FA4 145 LN (15-10)	214,4	125	302
FA4 160 LN (15-10)	226,1	125	331
FD4 088 LN (26-20)	152	80	175
FD4 102 LN (26-20)	172,2	95	214
FD4 117 LN (26-20)	198,4	110	227
FD4 130 LN (26-20)	225,1	125	234
FD4 10X LN (26-20)	172,2	95	190
FD4 145 LN (26-20)	250,8	125	302
FD4 160 LN (26-20)	264,6	125	331
FD4 088 LN (15-10)	129,7	80	175
FD4 102 LN (15-10)	147,5	95	214
FD4 117 LN (15-10)	169,9	110	227
FD4 130 LN (15-10)	192,9	125	234
FD4 10X LN (15-10)	147,5	95	190
FD4 145 LN (15-10)	216,4	125	302
FD4 160 LN (15-10)	228,5	125	331

AFC	Nominal fluid flow	Min fluid flow	Max fluid flow*
Model (#)	[m <sup>3</sup> /h]	[m <sup>3</sup> /h]	[m <sup>3</sup> /h]
FAL 077 (15-10)	143.5	95	148
FAL 089 (15-10)	159.6	95	199
FAL 101 (15-10)	193.2	110	309.8
FAL 116 (15-10)	222.1	125	292
FAL 127 (15-10)	242	145	318.9
FAL 138 (15-10)	266.1	160	318.9
FAL 077 LN (15-10)	135.9	95	148
FAL 089 LN (15-10)	150.2	95	199
FAL 101 LN (15-10)	182.4	110	309.8
FAL 116 LN (15-10)	209.7	125	292
FAL 127 LN (15-10)	228.6	145	318.9
FAL 138 LN (15-10)	251.2	160	318.9
FDL 077 (15-10)	144.9	95	148
FDL 089 (15-10)	161.2	95	199
FDL 101 (15-10)	195	110	309.8
FDL 116 (15-10)	224.3	125	292
FDL 127 (15-10)	244.4	145	318.9
FDL 138 (15-10)	267.8	160	318.9
FDL 077 LN (15-10)	137.6	95	148
FDL 089 LN (15-10)	152.3	95	199
FDL 101 LN (15-10)	184.8	110	309.8
FDL 116 LN (15-10)	212.5	125	292
FDL 127 LN (15-10)	231.6	145	318.9
FDL 138 LN (15-10)	245.3	160	318.9

At every tone of grey is matched a size of 2 way by-pass valve.

## VPF solutions available for Liebert® AFC

Three types of variable primary flow logics are available on Liebert® AFC:

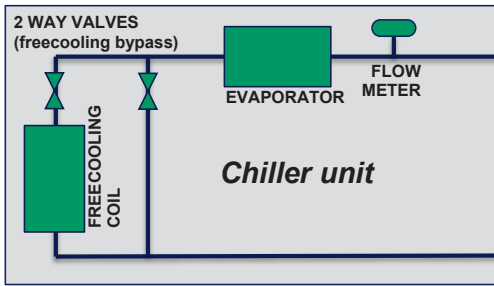

### VPF Solution A (digit 12 = 7):

- **AFC** without pump
- Embedded flow-meter reads the incoming variable flow
- The **AFC** thermal regulation logic automatically adapts to the flow conditions
- Unit limits (max / min flow, max variation speed) → if limits are exceeded, **AFC** delivers a warning and consequently an alarm

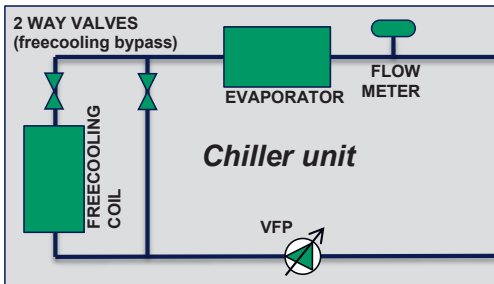

### VPF Solution B (digit 12 = 5 or 6):

- **AFC** with inverter pump (also available with second backup pump)
- **AFC** regulates the primary flow on the base of an external request (BMS) with signal 4-20 mA or 0-10 V
- The **AFC** thermal regulation logic automatically adapts to the flow conditions
- Unit limits (max / min flow, max variation speed) automatically ensured

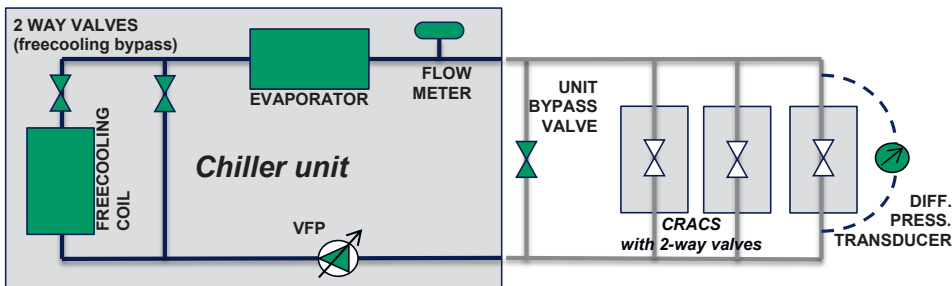

### VPF Solution C (digit 12 = 5 or 6 and additional accessory kit for Delta Pressure control):

- **AFC** with inverter pump (also available with second backup pump)
- **AFC** regulates the primary flow to maintain a Delta P in the circuit
- The solution package includes the following items to be installed on site:
  - Embedded differential pressure transducer
  - Embedded bypass valve for operation at loads near to zero

### Solution A (selectable with digit 12 = 7): unit without pump, predisposed for operation with variable primary flow.

The variable flow regulation is passive: the chiller doesn't include the primary pump. The chiller adapts its thermal regulation logic to the incoming variable water flow (provided by external pump) within the application limits indicated in the previous paragraph. This solution is recommended where external inverter pump are provided by customer; in this case it's necessary to take care about flow limits and fluctuation in order to let the unit works without warning / alarms; this solution could be applied to VPF system as well a primary / secondary water loop hydronic system where there's a variable flow on primary too.

For a multichiller application it's necessary a motorized gate valve at chiller's water inlet connection and a chiller sequencer or BMS able to manage both gate valve and chiller sequence / rotation.

It does not require any electrical connection.

**Solution B** (selectable with digit 12 = 5 or 6): unit with pump (or double pump), variable primary flow guided by external request (BMS).

The variable flow regulation is passive: the chiller regulates the primary flow on the base of an external request which must be provided with a signal 4-20 mA or 0-10 V, within the application limits indicated in the previous paragraph. This solution is recommended where inverter pump are managed but not provided by customer; In this case BMS has to take care about flow limits and fluctuation in similar way as for solution A, but with the additional benefit that the control of **Liebert® AFC** provides a higher level of safety, as it is capable of filtering the external BMS request in order to avoid flow warning or alarms. This solution could be applied to VPF system as well a primary / secondary water loop hydronic system where there's a variable flow on primary too. Anyway on both cases it's necessary to have a BMS system able to read the hydronic plant flow conditions and managing properly the variable flow pump installed in the unit.

For a multi-chiller application for sure it's not necessary to foresee a motorized gate valve for each chiller, because each **Liebert® AFC** with this option is provided by a check valve on pump delivery; anyway the BMS have to manage not only the flow as above indicated but also chiller sequence / rotation.

See electrical diagram included with the chiller.

Connect Electrically the BMS signal to Device A12 (configurable optoisolator see the component's datasheet included on the documentation) using the terminal blocks :

- XA2: 1110 + 20V DC
- XA2: 1111 + 0VDC
- XA2: 1112 Signal.

**Solution C** (selectable with digit 12 = 5 or 6 and additional accessory kit for delta pressure control): unit with pump (or double pump), variable primary flow guided by **Liebert® AFC** based on circuit delta pressure. As standard, this solution is available for single chiller systems only.

The variable primary flow is active and guided by **Liebert® AFC**, in order to maintain a set of delta pressure on the CRAC units. It is very important to follow the installation indications for the unit's by pass valve (next to the chiller with the shortest by-pass pipe size according valve DN) and differential pressure transducer on the farthest pipe of the plant as indicated on above sketch. These components are supplied loose as a kit and their hydraulic connection and electrical wiring to **Liebert® AFC** has to be done locally.

The hydraulic balancing valve must be positioned downstream of tank, chiller and two way the by-pass valves.

The bypass valve (managed by unit control) ensures that the amount of the flow that returns to the operating chiller never falls below the minimum limit.

The following table shows the correct match between each model and the associated kits showing min flow and valve/motor general characteristics.

Kit p/n	Min flow with 30% e.g.	Kv	By pass 2 way valve	DN valve	Motor valve	Press. Transducer
	[mc/h]					
455545	30 to 50	63	VVF32.65-63	DN65	SKB62	Typ 692 0-160 Kpa
455546	51 to 80	100	VVF32.80-100	DN80	SKB62	Typ 692 0-160 Kpa
455547	81 to 160	160	VVF32.100-160	DN100	SKC62	Typ 692 0-160 Kpa

**NOTE:** IP54 motor with spring return, heating element

The delta pressure set-point on the CRAC units is configurable (between min 60 kPa→limit on valve selection and max 160 kPa→limit on pressure transducer reading)

Usually DP set is bigger or equal to CRAC unit pressure drop at full

load for having the design water flow at full load through the entire hydraulic loop and a single CRAC unit itself .

**Liebert® AFC** will manage the pump speed in order to keep a constant DP on their water loop. When the waterflow requested by the CRAC unit is lower than the minimum water flow admitted by the chiller, the two way bypass valve starts to open in order to keep the min flow through the chiller and in the same time maintaining the DP requested on CRAC water loop.

To ensure a stable system and avoid fluctuations, it is preferable to have a carefully balanced hydraulic system on the CRAC units side. For this reason, 2 way pressure independent valves (PRIV) on CRAC units are recommended.

See electrical diagram included with the chiller.

Connect Electrically the differential pressure transducer (DP water) to Device A12 (configurable optoisolator) using the terminal blocks:

- XA2: 1110 + 20V DC
- XA2: 1111 + 0VDC
- XA2: 1112 Signal.

Connect Electrically the unit bypass valve (Ybypass see the component's datasheet included on the documentation) to Device A12 (configurable optoisolator see the component's datasheet included on the documentation) using the terminal blocks :

- XC: 1115 GND signal
- XC: 1116 signal + 0VDC
- XC: 1117 0V AC supply
- XC: 1118 +24V AC supply

Set the unit bypass valve (Y bypass) as described on the electrical diagram

Install and connect Electrically the heating unit bypass valve (Y bypass Heating see the component's datasheet included on the documentation) using the terminal blocks :

- XC: 1117 0V AC supply
- XC: 1118 +24V AC supply

## 5 - Refrigerant and Oil Charge

All work on pipes or components of the refrigerating circuit under pressure must be exclusively made by qualified staff, competent in such works.

### 5.1 - Refrigerant charge



#### NOTICE

**WHILE REPAIRING THE REFRIGERATING CIRCUIT RECOVER ALL THE REFRIGERANT IN A CONTAINER: DO NOT ALLOW IT TO ESCAPE. NEVER USE THE COMPRESSOR FOR THE SYSTEM VACUUM (THIS INVALIDATES THE WARRANTY).**

- The unit is delivered charged according to the *Tab. 4- Refrigerant charge*.

#### Warning for the refrigerant charge:

- Ensure there are no water leaks.
- Check the refrigerant charge in the refrigerating circuit: a unit originally charged by the manufacturer with R134a/R513A cannot be charged with other gas; possibly apply to the Technical Support Department.
- Charge with the compressor in operation, connecting the cylinder with the charge connector after the thermostatic expansion valve.
- Drain the connection pipe between the cylinder and the charging point; tighten the seal joint and then start charging

- the unit. It is imperative that the cylinder is weighed both before and after the operation.
- Charge the unit until the bubbles in the sight glass have disappeared and the working conditions of the entire refrigeration circuit have returned to normal (sub-cooling and superheating within the limits indicated below).
  - Measure the superheat as follows:
    1. Detect the temperature on the suction line, close to the bulb of the thermostatic expansion valve, using a contact thermometer.
    2. Connect a pressure gauge (by max. a 30 cm pipe) with the Schraeder connection and read the corresponding saturated evaporating temperature.
    3. The superheat is the difference between the two readings.
      - Verify that the superheat is 4 °C - 8 °C.
  - Measure the sub-cooling as follows:
    1. Detect the temperature on the liquid line using a contact thermometer.
    2. Connect a pressure gauge (by max. a 30- cm pipe) with the Schraeder connection on the liquid line and read the corresponding saturated condensing temperature.
    3. The sub-cooling is the difference between the two readings.
      - Verify that at the condenser outlet, sub- cooling is 4 °C - 8 °C.

**IT IS IMPORTANT TO CARRY OUT CHARGING CORRECTLY.**

An excess of refrigerant causes an increase in sub-cooling and consequent operating difficulties in the hot season; a shortage of charge generates an increase in superheating and possible compressor stoppages. Whenever work is carried out on the unit, ensure afterwards that the working conditions are correct, checking sub-cooling and superheating. Check the oil level in each compressor, after a short operating time.

**5.2 - Oil charge**

Contact the TechnicalSupport Department for the specifications of the oil to be used for topping up; the oil changes according to the typ of used refrigerant.



**NOTICE**

NEVER MIX DIFFERENT OILS TOGETHER. CLEAN THE PIPING COMPLETELY BEFORE CHANGING THE TYPE OF OIL USED.

TOP-UPS OF UP TO 20-30% OF THE TOTAL AMOUNT OF OIL CONTAINED IN THE COMPRESSOR CRANKCASE ARE PERMITTED; FOR LARGER PERCENTAGES CONTACT THE TECHNICAL SUPPORT DEPARTMENT.

**5.2.1 - Procedure for oil topping-up**

If there has been any loss of oil then this must be topped up as follows:

1. Take a clean, dry, transparent container (with volume calibrations) and fill it with at least twice the amount of oil required.
2. Isolate the compressor by closing the delivery and suction cocks (or the one on the liquid line).
3. Connect to the fittings on the compressor body (Schraeder valves) and empty it of refrigerant until atmospheric pressure (1 bar) is reaching.
4. Using a pipe, connect the oil container to the oil service cock on the lower central part of the compressor.
5. Open the oil service cock lifting the container, so that the oil flows by gravity.
6. Charge the required quantity of oil (make sure the tube always remains below the oil level).
7. Close the oil service cock, open the shut-off cocks of the compressor and on the refrigerating circuit and restore the drained refrigerant charge.

**6 - Calibration**

The water unit has been already tested and calibrated by the manufacturer. The following setting values are suggested in the field.

**R134a/R513A**

COMPONENT	SETTING	NOTES
<b>Low pressure switch (LP)</b> (managed by electronic control iCOM™)	Operation with R134a/R513A (standard factory setting): START : 1,2 bar DIFF. : 0,1 bar STOP : 1,1 bar	
<b>High pressure switch (HP)</b>	Operation with R134a/R513A (standard factory setting for FA4/FD4): STOP : 20,0 bar START : 16,0 bar DIFF. : 4,0 bar (fixed) (standard factory setting for FAL/FDL/CDL/ CAL) STOP: 18,0 bar START: 14,0 bar DIFF: 4,0 bar	

The settings for the safety valves installed on the machine are indicated below:

MODELS	SETTING	SAFETY VALVE
FA4 088 - 102 - 117 - 130 - 10X - 145 - 160 FD4 088 - 102 - 117 - 130 - 10X - 145 - 160	22 bar	High Pressure side (HP)
	14 bar	Low Pressure side (LP)
FAL, FDL 077 - 089 - 101 - 116 - 127 - 138 CAL, CDL 077 - 089 - 101 - 116 - 127 - 138	20 bar	High Pressure side (HP)
	14 bar	Low Pressure side (LP)

### 6.1 - Electronic expansion valve

The electronic expansion valve used in the **Liebert® AFC** range enables accurate and min. possible control of the overheating of the gas sucked by the compressor under all load conditions, together with the operation at low condensation and high compressor choking. Under such application conditions a mechanical expansion valve can never reach the performance ensured by an electronic expansion valve (with energy benefits) nor the functional stability, above all during the transients of the load variations (with benefits as for reliability).

The final result of the application of the electronic expansion valve on **Liebert® AFC** is therefore an improved energy operating costs and a higher reliability, thanks to its special adjustment features above all on partial loads, conditions under which every unit operates for most of the time. The operating parameters and their programming in the microprocessor dedicated to the EEV control are described in the suitable iCOM™ manual available on the machine.

The valve has already been factory-set and superheat should be reset only when it's not between 5°C and 8°C or it's present oil foam (visible on compressor's oil sight glass).



**NOTICE**  
**THIS OPERATION MUST BE PERFORMED BY AN EXPERIENCED REFRIGERATION TECHNICIAN.**

Before beginning this calibration be sure that the refrigerant charge is correct: this is obtained through the sub-cooling (4-8°C, as specified in *para. 5.1*).

Compressor's suction pressure, temperature and superheat could be read on iCOM™ control display as described in the suitable iCOM™ manual available on the machine.



**NOTICE**  
**PLEASE CHANGE SUPERHEAT SETPOINT ONLY WHEN RELEVANT COMPRESSOR IS OFF; IT'S NOT ALLOWED TO CHANGE EEV SUPERHEAT SETPOINT WHEN THE RELEVANT COMPRESSOR IS RUNNING.**

If the superheat is too low, there is a risk of poor lubrication and consequent breakage of the compressor as a result of pressure shock. If the superheat is too high the output of the system is limited and the compressor overheats.

### 6.2 - Condensing control

It is necessary to control the condensing temperature when it decreases below the lowest one allowed by the compressor due to a decrease in the temperature of the external air.

**Liebert® AFC** condensation control maximizes the unit Efficiency in freecooling mode too.

**Liebert® AFC** can operate in two modes:

- Freecooling not available, mechanical cooling only: when the condensing pressure decreases below a min. setpoint value (to be set) the Fans are reduced till reaching a stable operating point inside the dead band of the condensing pressure according to the setpoint. Consequently, the Fans always run at maximum speed, except in some critical situations due to transient state or wrong settings.

- Freecooling available and mechanical cooling: when the condensing pressure decreases below the setpoint value, the Fans are reduced. The fan speed is adjusted so that the condensing pressure falls within the setpoint pressure dead band.

### 6.3 - Environment protection

A misuse or an incorrect calibration of the unit leads to increased energy consumption, resulting in an economic and environmental damage. Use the freecooling function and the System adiabatic, if available.

## 7 - Maintenance

The Maintenance Program below must be carried out by a qualified technician, preferably working under a maintenance contract.



#### CAUTION

Before the checks below make sure the unit power supply line is disconnected at the start. Make sure the disconnection device is locked and the suitable warning plate for no operation is applied on the start handle.

Before operating on the electrical connections, make sure there is no voltage through a voltmeter or a phase detector.

Some components (electronic pumps, Fans EC, compressor's capacitors, soft-start, inverter) may remain high voltage for a short period after power supply removal. Wait at least **5** minutes to remove their electrical box panels and access to their parts under tension.

Before any intervention on the unit or accessing the inner components, always ensure the machine is turned off. The front part of the compressor and the delivery pipe are very hot: be careful when operating nearby. Be very careful when operating close to the finned coils, as the fins are very sharp. Do not remove the fan protection grille before having shut the whole machine off; do not insert foreign objects through the fan protection grille. After the maintenance interventions, always close the unit by refitting the relevant panels, fastened by the fixing Helicals.



#### WARNING

About the maintenance program of System adiabatic, see *Chap. 8* of "Adiabatic Cooling System Integration" User Manual.

## 7.1 - Coil cleaning procedures

The unit operating environment can remarkably influence the life of the microchannel condensers. The table below compares microchannels with and without e-coating for various environments.

Cleaning frequently and accurately the microchannel coil improves the unit Efficiency in time and extends its life.

	Unpolluted rural	Unpolluted urban	Costal	Industrial	Combined costal & industrial
MCHE	:)	:)	:	:	:(
MCHE E- coating	:)	:)	:)	:)	:
:  Recommended; :  Acetable when protection is applied; :( Not recommended					

The obstructions provided by powder, pollution etc. accumulated between the coils fins can be removed by means of a pressure washer.

This operation shall be periodically executed.

### Before operating:

1. disconnect the unit from the electrical power supply;
2. wait until the Fans are completely stopped;
3. ensure that the Fans impellers cannot move for any reason (e.g.: wind). Block them mechanically to avoid accidental contacts with the rotating blades.
4. if present remove the System adiabatic as described in Adiabatic Cooling System Integration User Manual.
5. remove the air filters and the V-shaped panels, if any.
6. remove the long and narrow panel between the microchannel coil and the freecooling.

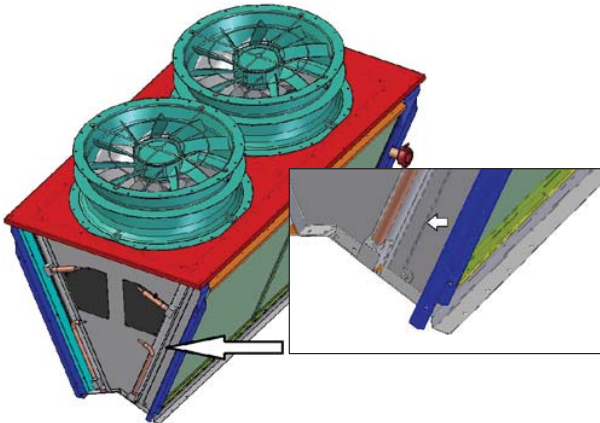

7. insert the partition between microchannel and freecooling so that the lower channel faces the Freecooling coil.

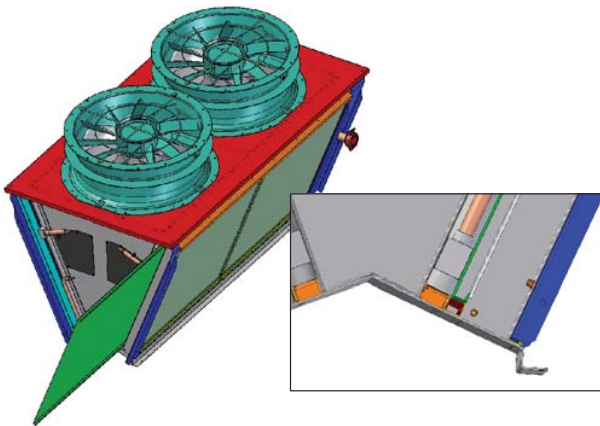

8. wash the Freecooling coil with a nozzle at a distance of approx. 20 cm from the coil surface.



### NOTICE

Higher pressure values and/or using the nozzle at a distance shorter than 20 cm from the coil surface may damage the microchannel coil.

9. dry the coil using an air compressor.
10. remove and rotate the sheet so that the lower channel face the microchannel condenser.
11. Wash the microchannel coil with a nozzle at a distance of approx. 5 cm. A nozzle with straight angle flow must be available to use the windows on the V-shaped partition. If this type of nozzle is not available, the Fans must be removed and introduce the water nozzle in the internal space of the unit.

For better results, the water jet must be as perpendicular as possible to the surface.

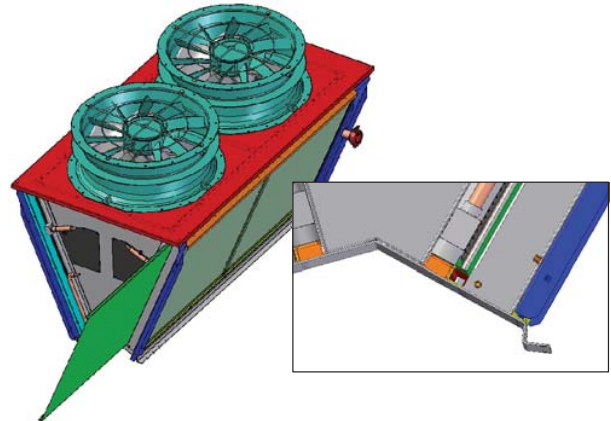

### NOTICE

Higher pressure values and/or using the nozzle at a distance shorter than 5 cm from the coil surface may damage the fins of the Freecooling coil.



### NOTICE

Do not use any chemical product to wash the microchannel condenser. This can cause corrosion!

12. Dry the microchannel by an air compressor.



### DANGER

It is forbidden to climb on the roof of the unit without proper PPE as local safety regulations!

13. Remove the sheet.
14. If removed, mount the Fans.
15. If present mount the System adiabatic as described in Adiabatic Cooling System Integration User Manual.



#### NOTICE

About the cleaning of System adiabatic and PADs, follow the indications present in *chapter 8* of “Adiabatic cooling system integration user manual”.



#### NOTICE

**DO NOT WASH THE PADS BY PRESSURIZED JET, IT DAMAGE THEM!**

In case of greasy obstructions, a specific neutral degreasing product can be used to ease the process.

After the cleaning operation, re-assemble the parts previously removed and unblock the blocked Fans before reconnecting to the electrical power supply.

### 7.2 - Compressor maintenance schedule - checks and tests

To protect against reverse rotation when stopped, a check valve is incorporated under the compressor’s delivery valve. If the compressor runs in reverse direction for more than **5 sec.** after switch-OFF, the valve may be damaged and should be replaced. Check the correct functioning every **5.000** compressor working hours.

Helical Compressor are equipped with fatigue resistant bearings, therefore replacement is not necessary provided that the refrigerant circuits are operated under standard conditions within the operating limits and respecting the indicated maintenance schedule. Bearing wear detection is to be carried out by sound analysis. The recommended inspection interval is every **10.000** compressor working hours. For preventive maintenance, the recommended interval for replacing the bearings is every **40.000** working hours of the Compressor.

Anyway, under the standard operating conditions of the **Liebert® AFC** units (resulting from the air-conditioning application where the condensation is mainly lower than 50° C in one operating year) the life limits of the bearings are not reached.

Due to occasional variations of the compressor standard operating conditions, such as: lack of oil, moisture in the refrigerant, insufficient superheating or thermal overload, the bearings may need to be replaced.

Please contact our Service department if it’s necessary to replace the compressor’s bearings: it’s avoid to open the Helical compressor out from authorized workshops.

### 7.3 - Lubrication - pump

The bearings of motors up to 11 kW are greased for life and require no lubrication. The bearings of motors of 11 kW and up must be greased in accordance with the indications on the motor name plate. The motor should be lubricated with a lithium - based grease meeting the following specifications:

- NLGI grade 2 or 3.
- Viscosity of basic oil: 70 to 150 cSt at 40 °C (aprox. +104 °F).
- Temperature range: - 30 °C (aprox. - 22 °F) to 140 °C (aprox. +284 °F) during continuous operation.

### 7.4 - Spare parts

The use of original spare parts is recommended. When placing an order refer to “Component List” enclosed with the machine and quote the unit model no. and serial no.



#### NOTICE

If one or more Compressor must be replaced, you must contact “**Vertiv™**” Service.

### 7.5 - Dismantling the unit

The machine has been designed and built to ensure continuous operation. The working life of some of the main components, such as the Fans and the Compressor, depends on the maintenance that they receive.



The unit contains substances and components hazardous for the environment (electronic components, refrigerating gases cartridge of dryer filter and oils). At the end of the useful life, when the unit is dismantled, the operation must be carried out by specialized technicians.

The unit must be delivered to suitable centers specialized for the collection and disposal of equipment containing hazardous substances. Electronic components, refrigerating fluid and the lubricating oil inside the circuit must be recovered according to the laws in force in the relevant country.

The used PADs are non-hazardous waste and must to be disposed according with the local norms in force.

## Maintenance programme

<b>FANS</b>	<ul style="list-style-type: none"> <li>• Check that the fan rotates freely without any abnormal noise, and ensure that the bearing is not running hot.</li> <li>• Also check the current absorption.</li> </ul>
<b>CONDENSER, AIR FILTER AND PADS</b>	<ul style="list-style-type: none"> <li>• Check the conditions of the filters and PADS (if they are supplied); if necessary clean them (including the electric board ventilation filter).</li> <li>• Check the microchannel condenser and clean if necessary (see coil cleaning procedures, <i>Par. 7.1</i>).</li> </ul>
<b>CONTROL</b>	<ul style="list-style-type: none"> <li>• Check that the control equipment, LEDs and display are operating correctly.</li> <li>• Check the supply voltage.</li> <li>• Check the operation of the compressor's oil heaters.</li> <li>• Check the correct operation of the Compressor' partialization solenoid valves.</li> <li>• Check the conditions of the power contacts of the contactors (Compressor, pumps, etc.).</li> <li>• Check the conditions of the remote control switch contacts.</li> <li>• Check the operation of the Evaporator resistance (if present).</li> <li>• Check the operation of the electrical panel fan and heaters (if present).</li> </ul>
<b>ELECTRICAL CIRCUIT</b>	<ul style="list-style-type: none"> <li>• Check the electrical supply on all phases.</li> <li>• Ensure that all electrical connections are tight.</li> </ul>
<b>REFRIGERATION CIRCUIT</b>	<ul style="list-style-type: none"> <li>• Check the condensing and the evaporating pressures (to be done by a refrigeration technician).</li> <li>• Check the compressor's current absorption, the delivery temperature and possible unusual noises.</li> <li>• Check the refrigerant charge by means of the sight glass.</li> <li>• Check that the safety devices operate correctly.</li> <li>• Check the correct operation of the EEV (superheating between 5° C - 8° C).</li> <li>• Check that the oil level indicated by the compressor sight glass is higher than the min. value.</li> </ul>
<b>CHILLED WATER CIRCUIT</b>	<ul style="list-style-type: none"> <li>• Ensure that there are no water leaks.</li> <li>• Bleed any air out of the hydraulic circuit using the bleed valve on the chilledwatercoil.</li> <li>• Verify the correct water flow inlet.</li> <li>• Check the inlet - outlet liquid temperature and pressure.</li> <li>• Check the correct operation of the two-way valves</li> <li>• Check if the system is charged with the specified glycol percentage and that no ice has formed in the hydraulic circuit.</li> <li>• Check the Evaporator cleanliness.</li> <li>• Check the motor pump current.</li> <li>• Check the motor pump noise.</li> <li>• Ensure the motor pump is periodically lubricated.</li> </ul>

## 7.6 - Regulation (EC) no. 517/2014 (F-gas)

### 7.6.1 Introduction

Stationary air conditioners placed into the European Community market and operating with fluorinated greenhouse gases (F-gas, such as R407C, R134a, R513A, R410A), have to comply with the F-gas Regulation (EU) No. 517/2014.

This Regulation is in force since Jan 1, 2015 and it replaces the Re. (EU) no. 342/2006.

This document summarizes the obligations for the operators that are responsible for the equipment during all its operative life until its disposal.

### 7.6.2 Normative References

<b>F-gas</b>	517/2014	Regulation (EU) No 517/2014 of the European Parliament and of the Council of 16 April 2014 on fluorinated greenhouse gases and repealing Regulation (EC) No 842/2006
<b>Certified personnel and Companies</b>	2015/2067	Commission Implementing Regulation (EU) 2015/2067 of 17 November 2015 establishing, pursuant to Regulation (EU) No 517/2014 of the European Parliament and of the Council, minimum requirements and the conditions for mutual recognition for the certification of natural persons as regards stationary refrigeration, air conditioning and heat pump equipment, and refrigeration units of refrigerated trucks and trailers, containing fluorinated greenhouse gases and for the certification of companies as regards stationary refrigeration, air conditioning and heat pump equipment, containing fluorinated greenhouse gases
<b>Leak check air conditioning</b>	1516/2007	Commission Regulation No 1516/2007 of 19 December 2007 establishing, pursuant to Regulation (EC) No 842/2006 of the European Parliament and of the Council, standard leakage checking requirements for stationary refrigeration, air conditioning and heat pump equipment containing certain fluorinated greenhouse gases
<b>Leak check fire protection systems</b>	1497/2007	Commission Regulation No 1497/2007 of 18 December 2007 establishing, pursuant to Regulation (EC) No 842/2006 of the European Parliament and of the Council, standard leakage checking requirements for stationary fire protection systems containing certain fluorinated greenhouse gases

From 01/01/2017 to be replaced by:

Commission Implementing Regulation (EU) 2015/2068 of 17 November 2015 establishing, pursuant to Regulation (EU) No 517/2014 of the European Parliament and of the Council, the format of labels for products and equipment containing fluorinated greenhouse gases

### 7.6.3 Fluorinated Greenhouse Gases

Following notes have to be considered when operating with the above mentioned equipments:

- Fluorinated greenhouse gases are covered by the Kyoto Protocol.
- The fluorinated greenhouse gases in this equipment should not be vented to the atmosphere.
- Referring to the value noted in Annex I and Annex IV of Regulation (EU) No 517/2014 here below the global warming potential (GWP) of some major F-gases or mixtures:
  - R-134a GWP 1430
  - R-407C GWP 1774
  - R-410A GWP 2088

**NOTE:** the refrigerants as R22 are not F-gas and their relevant regulation is Reg. (EU) no. 1005/2009.

## 7.6.4 Operators

### 7.6.4.1 Definitions

- Operator, according to Regulation 517/2014 Article 2, point 8, means the natural or legal person exercising actual power over the technical functioning of products and equipment covered by this Regulation.
- The State may, in defined, specific situations, designate the owner as being responsible for the operator's obligations.
- Where large installations are involved, service companies are contracted to carry out maintenance or servicing. In these cases the determination of the operator depends on the contractual and practical arrangements between the parties.

### 7.6.4.2 Obligations

Operators of stationary air conditioners, which contain fluorinated greenhouse gases, shall, using all measures which are technically feasible and do not entail disproportionate cost:

- Prevent leakage of these gases and as soon as possible repair any detected leakage.
- Ensure that they are checked for leakage by certified personnel.
- Ensure for putting in place arrangements for the proper recovery by certified personnel.
- According to Regulation 517/2014 the operators shall ensure that the equipment is checked for leaks as following:
  - Case 1** - Non-sealed equipment contains less than 5 tonnes of CO<sub>2</sub> equivalent of fluorinated greenhouse gases.
    - ▶ Leakage test not required
  - Case 2** - Hermetically sealed equipment contains less than 10 tonnes of CO<sub>2</sub> equivalent of fluorinated greenhouse gases.
    - ▶ Leakage test not required
  - Case 3**
    - ▶ **Leakage test required:** check the equipment for leaks with the minimum frequency given in the following table:

X = Tonnes of CO <sub>2</sub> Equivalent	Y = equivalent amount of refrigerant [kg]				Minimum frequency for leak check	
	R513A	R134a	R410A	R407C	with leakage detection	without leakage detection
5 ≤ X < 50	7,9 ≤ Y < 79	3,5 ≤ Y < 35	2,4 ≤ Y < 24	2,8 ≤ Y < 28	12 Months	24 Months
50 ≤ X < 500	79 ≤ Y < 790	35 ≤ Y < 350	24 ≤ Y < 240	28 ≤ Y < 282	6 Months	12 Months
X ≥ 500	Y ≥ 790	Y ≥ 350	Y ≥ 240	Y ≥ 282	3 Months	12 Months

- Recovery for the purpose of recycling, reclamation or destruction of the fluorinated greenhouse gases, pursuant to Art. 8 of the Regulation 517/2014 shall take place before the final disposal of that equipment and, when appropriate, during its servicing and maintenance.

### 7.6.5 Leakage Detection

The manufacturer approves the following leakage check methods according to Reg. 1516/2007 and Reg. 1497/2007:

Method	Specifications
<b>a</b> Check of circuits and components representing a risk of leakage with gas detection devices adapted to the refrigerant in the system	Gas detection devices shall be checked every <b>12</b> months to ensure their proper functioning. The sensitivity of portable gas detection devices shall be at least five grams per year.
<b>b</b> Application of ultraviolet (UV) detection fluid or suitable dye in the circuit	The method shall only be undertaken by personnel certified to undertake activities which entail breaking into the refrigeration circuit containing fluorinated greenhouse gases.
<b>c</b> Proprietary bubble solutions/soapsuds	---

## 7.6.6 Labelling

The label applied on the unit (see *Onboard Label*) is designed to fill-in the relevant amounts of refrigerant according to Regulation 1494/2007 (2015/2068):

- a** Where fluorinated greenhouse gas is foreseen to be added to the equipment outside of the manufacturing site at the point of installation, a dedicated label accommodates notation of both the quantity [kg] pre-charged in the manufacturing plant and of the quantity charged at the installation site as well as the resulting total quantity of F-gas as a combination of the above mentioned quantities, in a manner which conforms to the legibility and indelibility.  
Our split units are usually not pre-charged on factory, in this case the total quantity of refrigerant charged in the unit has to be written in the relevant label, during the commissioning operation at the installation site.  
All of the quantities of must be given both as mass of refrigerant [kg] and as Tonnes of CO<sub>2</sub> Equivalent.  
Use the following rule for computation:

$$\text{Tonnes of CO}_2 = \frac{\text{kg of refrigerant} \times \text{GWP of refrigerant}}{1000}$$

where:

Refrigerant	GWP
R-513A	631
R-134a	1430
R-407C	1774
R-410A	2088

- b** Our packaged units (not split) operating with f-gas are usually full charged on factory and the total amount of refrigerant charge is already reported on the label. In this case, the label has no need of further written information.
- c** In general, the above mentioned information has been located in the main nameplate of relevant unit.
- d** For equipment with double Obiegi chłodnicze, in regards to differentiates requirements on the basis of the quantity of F-gas contained, the required information about refrigerant charge quantities has to be listed separately for each individual circuit
- e** For equipments with separate indoor and outdoor sections connected by refrigerant piping, the label information will be on that part of the equipment which is initially charged with the refrigerant. In case of a split system (separate indoor and outdoor sections) without a factory pre-charge of refrigerant, the mandatory label information will be on that part of the product or equipment which contains the most suitable service points for charging or recovering the fluorinated greenhouse gas(es).

**NOTE:** *Safety data sheets of F-gases used in the products are available on demand.*

## 7.6.7 Record Keeping

Operators of equipment which is required to be checked for leaks (see 7.6.57.6.5 *Leakage Detection*), shall establish and maintain records for each piece of such equipment specifying the following information:

- a** the quantity and typ of fluorinated greenhouse gases installed
- b** the quantities of fluorinated greenhouse gases added during installation, maintenance or servicing or due to leakage
- c** whether the quantities of installed fluorinated greenhouse gases have been recycled or reclaimed, including the name and address of the recycling or reclamation facility and, where applicable, the certificate number
- d** the quantity of fluorinated greenhouse gases recovered
- e** the identity of the undertaking which installed, serviced, maintained and where applicable repaired or decommissioned the equipment, including, where applicable, the liczba its certificate
- f** the dates and results of the leak checks carried out (see 7.6.57.6.5 *Leakage Detection*)
- g** if the equipment was decommissioned, the measures taken to recover and dispose of the fluorinated greenhouse gases

Unless the records are stored in a database set up by the competent authorities of the Member States the following rules apply:

- a** the operators shall keep the records for at least five years
- b** undertakings carrying out activities for operators shall keep copies of the records for at least five years

## 8 - Options and Accessories

### 8.1 - Pumps Group

All the models can be equipped with twin water circulating pumps mounted on-board and factory piped. It is possible to select the pump typ (low or high head) on each unit, both in the standard version and in the one with inverter and integrated electronic adjustment. All pumps are dynamically balanced according to ISO 1940 class 6.3. The electronic pump adjustment algorithm enables to modulate the pump speed to keep the delivery steady through the Evaporator even if the hydraulic load changes; in this way, a significant energy saving is achieved and varies depending on the applications. In particular, in the Freecooling units this benefit is obtained above all in summer, when the Freecooling coil is short-circuited. The programming of the adjustment set of the electronic pump can be by an infrared remote control, contact your dealer.

They are suitable for operation with water-ethylene glycol mixture up to 35/65 % by weight and coolant fluid temperatures down to 4°C. The Pumps are of the close-coupled centrifugal typ, direct driven, with two-pole electric motor having IP54 protection, Class F insulation and Efficiency class 1 (according to CEMEP). The motors with this Efficiency class (the highest) ensure a higher energy saving than the pump with lower Efficiency class; further, they enable a more silent operation of the motor and can reach very high use limits of the room temperature (up to 60 °C). Pump casings are in cast iron, impellers in cast iron, shafts in stainless steel and the mechanical seals in silicon carbide/ EPDM with Dimensions according to EN12756, suitable for the use of coolant containing ethylene glycol. The Pump hydraulic circuit includes a discharge check valve for each pump. The pump body, the stator body and the fastening bolts and nuts are electrophoretically painted; such pumps can thus be used in outdoor places subject to weather agents without corrosion problems. Each pump also has an automatic circuit breaker.

Microprocessor controls manage the pump rotation and stand-by and automatically start the stand-by pump in case of failure of the primary one. In the versions with inverter and integrated electronic adjustment only the first pump is equipped with these devices: the second one is a standard pump operating only if the first one is in alarm. The microprocessor will start the second pump for a short period every week so as to avoid locks and/or deposits on the propeller due to a long inactivity.

In case of electronic inverter pump replacement it's necessary to set all deep parameter (user panel is not feasible for this operation); this operation must be performed by an experienced **Vertiv™** technician.

For the Technical properties and the hydraulic schematic see *Tab. 6* and *Fig. 11*.

### 8.2 - Hydraulic kit

Made up of an expansion tank (pre-charged at 1.5 bar, max. operating pressure 10 bar) and a safety valve set at 6 bar. Their position in the hydraulic circuit is illustrated in figures *Fig. 11*.

Expansion tank volumes: 12 litres

It is recommended that the total required expansion tank capacity is always checked, depending on the unit's internal hydraulic volume, the user circuit volume, the glycol percentage in the mixture, and the expected maximum temperature variation of the mixture.

### 8.3 - Economiser

The operation with economizer is a convenient and efficient method to increase the Cooling capacity and the COP. This device is particularly advisable for the conditioning applications where the condensing temperatures are high or medium.

By this operation system, the liquid refrigerant is cooled by a heat exchanger (sub-cooler).

When a sub-cooler is used, some of the refrigerant mass (ECO flow rate) is separated from the condenser mass after the condenser (4).

This ECO mass is thus expanded at an intermediate pressure (t ms).

The ECO mass evaporates inside the sub-cooler and enters the compressor through the economizer opening.

The Evaporator mass flow rate is sub-cooled by the exchanger at a lower liquid temperature (4u).

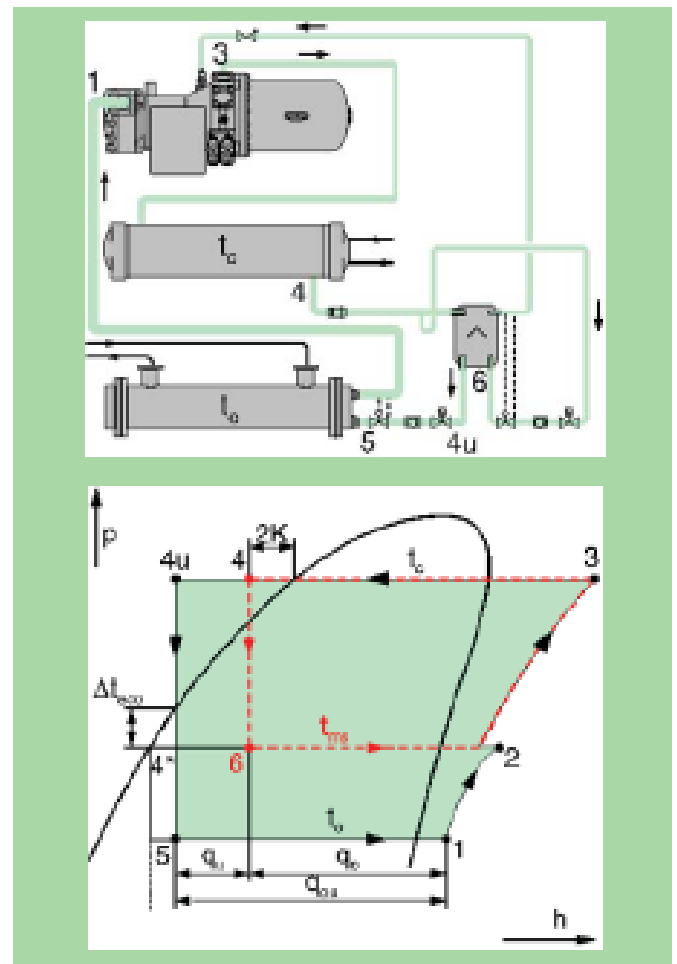

The intermediate pressure at the economizer changes depending on the type of compressor, on the operating conditions (evaporations and condensation temperatures) and on the ECO flow rate.

The additional sub-cooling of the liquid involves a significant increase of the Cooling capacity.

From certain operating conditions, the electric absorption by the compressor increases less proportionally than the Cooling capacity (improving the machine Efficiency), as the compression process occurs at a better Efficiency level due to the positive contribution of the fresh gas portion sucked through the ECO opening.

A further feature of the economizer circuit in the **Liebert® AFC** units is the slide valve for choking the compressor, equipped with an integrated economizer channel; this ensures the above described benefits, due to the additional sub-cooling, independently of the machine load conditions and thus of the position of the slide valve for the compressor choking.

The operation enabling/disabling of the economiser cycle is carried out by the microprocessor through opening the relevant solenoid valve (see refrigerating schemes *Fig. 10*), after the machine has reached stable operating conditions and the condensation saturated pressure falls within a range  $35^{\circ}\text{C} < T_{\text{cond}} < 58^{\circ}\text{C}$ . Check the correct operation of the thermal expansion valve of the economiser circuit (with the same procedures indicated in *par. 6.1*) checking that the overheating ranges between  $5^{\circ}\text{C}$  and  $8^{\circ}\text{C}$ .



**CAUTION:**

The expansion valves do not feature MOP, thus injection saturated pressure in a range between  $10^{\circ}$  and  $30^{\circ}\text{C}$  can be read as a rule.

**8.4 - Energy meter (optional)**

For a full description please look at manual available on the unit. Parameters device are set on factory; it can show:

- currents;
- powers;
- energy values.

**8.5 - Water meter**

**Characteristics :**

- Flow rate range 0.1 to 6 m/s (0.3 to 20 ft/s)
- Installs into pipe sizes DN15 to DN900 (½ to 36 in.)
- High resolution and noise immunity
- Chemically resistant materials
- Easy to replace rotor

**Safety informations:**

1. Depressurize and vent system prior to installation or removal.
2. **DO NOT** exceed maximum temperature or pressure specs.
3. **ALWAYS** wear safety goggles or faceshield during installation and/or service.
4. **DO NOT** alter product construction.

2536 Sensor (with blue cap)



	<b>Warning / Caution / Danger</b> Indicates a potential hazard. Failure to follow all warnings may lead to equipment damage, injury, or death
	<b>Personal Protective Equipment (PPE)</b> Always utilize the most appropriate PPE during installation and service of Signet products.
	<b>Pressurized System Warning</b> Sensor may be under pressure, take caution to vent system prior to installation or removal. Failure to do so may result in equipment damage and/or serious injury.
	<b>Hand Tighten Only</b> Overtightening may permanently damage product threads and lead to failure of the retaining nut.
	<b>Do Not Use Tools</b> Use of tool(s) may damage product beyond repair and potentially void product warranty.



**WARNING!**

**Paddlewheel Retaining Nuts:**

The retaining nuts of paddlewheel sensors are not designed for prolonged contact with aggressive substances. Strong acids, caustic substances and solvents or their vapor may lead to failure of the retaining nut, ejection of the sensor and loss of the process fluid with possibly serious consequences, such as damage to equipment and serious personal injury.

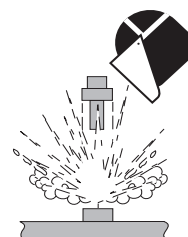

Retaining nuts that may have been in contact with such substances, e.g. due to leakage or spilling, must be replaced. Max. pressure : 12.5 bar at 20°C.

**Standard Sensor Installation**

- Lubricate O-rings with a non-petroleum based, viscous lubricant (grease) compatible with the system.
- Using an alternating/twisting motion, lower the sensor into the fitting, making sure the installation arrows on the black cap are pointing in the direction of flow, see *Figure A*.
- Engage one thread of the sensor cap then turn the sensor until the alignment tab is seated in the fitting notch.

**Hand tighten the sensor cap.**



**DO NOT** use any tools on the sensor cap or the cap threads and/or fitting flange threads will be damaged, see *Figure B*.

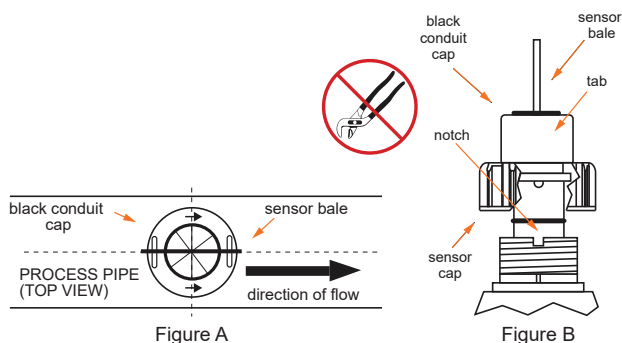

## 9 - Electrical Panel and Unit Control

The electrical panel is designed, constructed and tested in compliance with IEC standards (EN60204-1).

It is divided into two sections (power and control) with an accessible door to the control display section (without door interlock) in order to allow maintenance. Checking, adjustment operation without switching off the unit.

The electrical panel has a degree of protection equivalent to IP54 with closed doors, with doors open IP2x.

The cooling of the electrical panel is achieved through forced ventilation. For low ambient temperatures (suggested for  $T < -5$  °C) it is possible to have an electric heater fitted inside (optional).

### Main features:

- power supply: 400V  $\pm 10\%$  / 3Ph+PE / 50Hz  $\pm 1\text{Hz}$ ;
- auxiliary power supply (optional): 230V  $\pm 10\%$  / 1Ph+N+PE / 50Hz  $\pm 1\text{Hz}$ ;
- auxiliary power circuit: 230V/1Ph/50Hz, 24Vdc, 24V/1Ph/50Hz
- main switch;
- $I_{cw}(1s)=20\text{KA}$  ( $I_{pk}=42\text{KA}$ )
- main switch for auxiliary circuit and fast start feature (optional);
- protection MCBs for Fans and pumps;
- fuses and thermal relays for compressor and timer for star/delta connections
- contactor for Compressor and pumps;
- relay for checking phase sequence, minimum voltage, loss one or more phase ;
- manual operation through iCom for AFC control;
- PFC (Power Factor Correction) for Compressor (option);
- EEV with safety dedicated capacitor buffer module (ULTRACAP);
- Energy Meter fitted on electrical panel board;
- dry contacts for remote indication of:
  - Compressor in operation;
  - pump(s) in operation;
  - general alarm;
  - warning alarm.
- 24Vac relays supplied from customer for:
  - remote ON/OFF;
  - configurable digital input;
  - emergency draining of adiabatic tank side 1;
  - emergency draining of adiabatic tank side 2.
  - STOP PFC

### 9.1 - Double Power Supply, UltraCap and Fast Start Ramp

The **iCOM™ for AFC** control is fed by direct current for immunizing from network disturbances.

There are 4 possible power supply choices, to guarantee reliability and fast start:

#### Option 0

The unit is powered by a single three-phase line.

The control is powered by an AC/DC converter, three-phases, that insulate the control from the external electric noises.

#### Option 1 (Fast Start Ramp – Easy)

The unit is powered by a single three-phase line.

A capacitors module (ULTRACAP) is installed for the direct microprocessor power supplying.

In case of main supply **POWER OFF**, the control is powered for **90** seconds (minimum buffer time, the amount of time depends on the unit configuration).

At the main supply power restore within the buffer time, the control re-starts quickly the controlled components (pumps, Fans, valves, Compressor, etc.).

At the main supply power restore out of the buffer time, the ULTRACAP requires **15** minutes to recharge completely.

More repetitions of **POWER OFF** in a short time and/or long **POWER OFF** time reduce the minimum buffer time. ULTRACAP has a potentially unlimited lifetime, working temperature limits from  $-40$  to  $+60$  °C and does not require any maintenance.

#### Option 2 (Fast Start Ramp – Classic)

The unit is powered by two power lines.

A three phase line for the motors and other high power components.

A single phase for the control, typically provided by a UPS installed by the customer/user.

The control is powered by a AC/DC single-phase converter, connected to the single-phase power line, that insulate the control from the external electric noises.

In case of **POWER OFF** of the three-phase line, the control remains power supplied by its dedicated power supply line, ready to start quickly at the three-phase **POWER ON**.

#### Option 3 (Fast Start Ramp – Double Backup)

It is the more complete and robust configuration.

It is composed by:

- 1AC/DC converter, three-phase, connected to the main supply line.

- 1 AC/DC converter, single-phase, connected to the single phase for the control, typically provided by a UPS installed by the customer/user.

- 1 redundancy module that switches between the two lines to power the ULTRACAP, giving priority to the main.

- 1 ULTRACAP capacitors module to power the microprocessor; in case of **POWER OFF** of the dedicated line the control is powered for **90** seconds (minimum buffer time, the amount of time depends on the unit configuration).

#### The unit is powered by two lines:

A three phase line for the motors and other high power components.

A single phase for the control, typically provided by a UPS installed by the customer/user.

This configuration improves the option 2, giving a further possibility of fast re-start in case of power **OFF** of the single-phase power line.

The main power supply of the ULTRACAP must be set adjusting the output voltage of the AC/DC converters (three-phases and single-phase) using the dedicated trimmer.

The system has two different possibilities:

- AC/DC three-phases converter as main ULTRACAP power supply (default).

The unit is completely powered by the three-phaseline, the control too.

In case of **POWER OFF** the redundancy modules with the power supply to the AC/DC single-phase, electrically fed by its dedicated line, typically provided by a UPS installed by the customer/user. The control is powered until the single-phaseline is **ON** or until the ULTRACAP is active (buffer time **90** seconds). If the three-phase power line is restored when the control is still powered, the controlled components (pumps, Fans, valves, Compressor, etc.) are re-started quickly (fast-start).

- AC/DC single-phase converter as main ULTRACAP power supply.

The unit is powered by two power lines: the main three-phase line feeds the main uses (mainly motors); the auxiliary single-phase line feeds the control.

In case of POWER OFF the control is powered by the auxiliary line ready to re-start quickly (fast-start) the controlled components (pumps, Fans, valves, Compressor, etc.).

In case of auxiliary line POWER OFF, the redundancy module switches the power supply to the AC/DC three-phase converter (powered by the main line), without any consequences for the unit. In case of additional POWER OFF of the main line, the control is powered until the ULTRACAP is active (buffer time 90 seconds).

Three possible events can occur:

1. No power resume within the ULTRACAP buffer time: the control is powered OFF; the unit shall re-start with a regular start-up as the main power is ON.
2. Main power ON within the buffer time: the unit restarts in fast-start mode and the ULTRACAP is recharged.
3. Auxiliary power ON within the buffer time: the redundancy module switches on the AC/DC single-phase converter, feeding the control and recharging the ULTRACAP. As the main power is ON, the fast-start is possible.

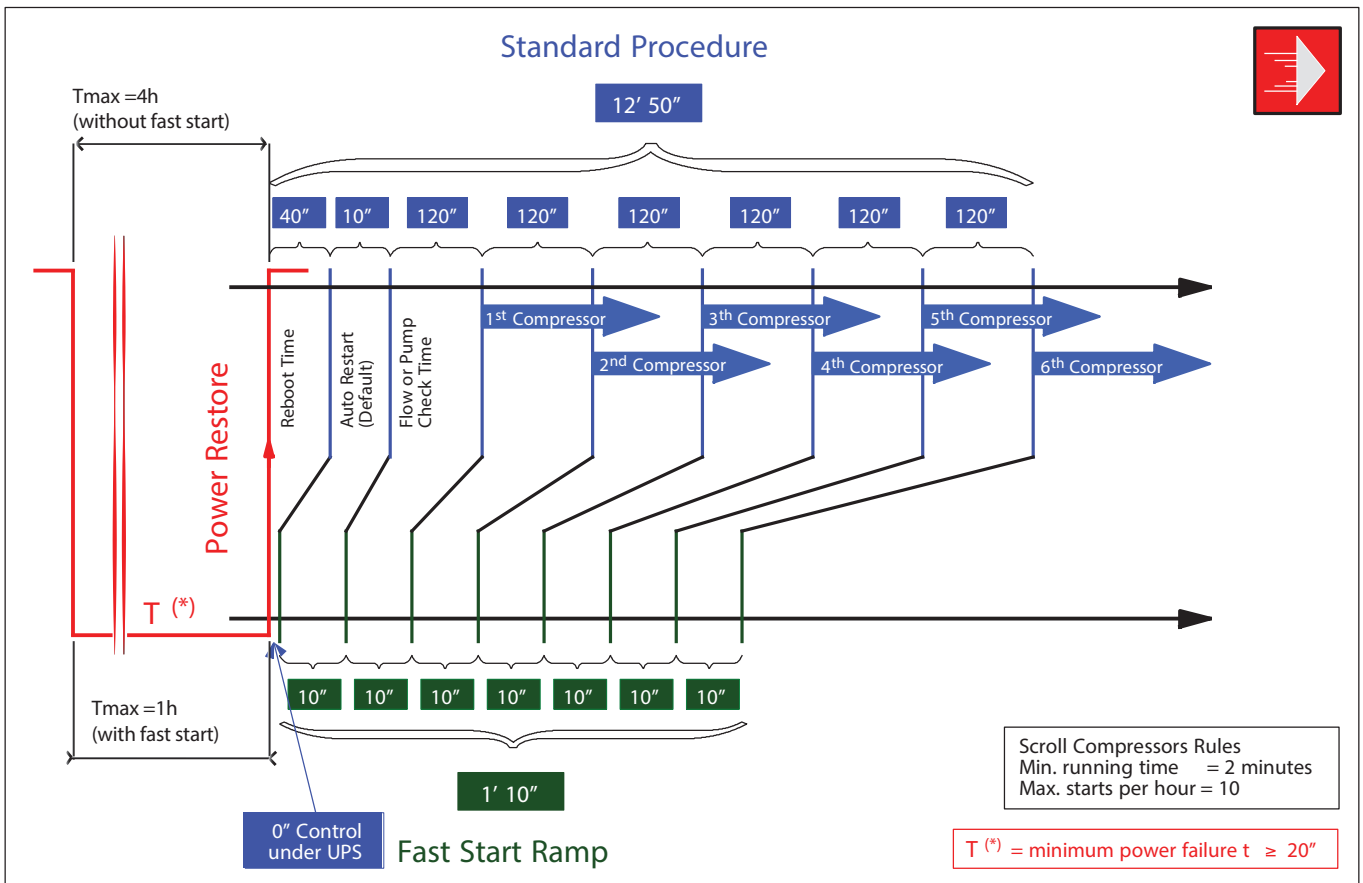

## 9.2 Controls: indicative capacity/ Efficiency data

Liebert® AFC can support as optional devices:

- **ENERGY METER** which provides the instant electrical power consumption reading (including primary pump consumption if this is integrated in the unit)
- **CHILLED WATER FLOW METER** which provides the chilled water flow speed (m/s)
- **ADIABATIC FLOW METER** which provides the flow reading (l/h) on adiabatic side (only if adiabatic tanks are present)

**IF CHILLED WATER FLOW METER IS PRESENT UNIT CONTROL IS ABLE TO ELABORATE THE FOLLOWING CALCULATED DATA OUTPUT**

- Total Capacity (KW)
- Mechanical Capacity (KW)
- Free Cooling capacity (KW)

**IF BOTH CHILLED WATER FLOW METER AND ENERGY METER ARE PRESENT UNIT CONTROL IS ALSO ABLE TO ELABORATE THE FOLLOWING CALCULATED DATA OUTPUT**

- **EER** (including primary pump consumption if this is integrated in the unit)
- **pPUE** (including primary pump consumption if this is integrated in the unit)

**IF BOTH CHILLED WATER FLOW METER AND ADIABATIC WATER METER ARE PRESENT UNIT CONTROL IS ABLE TO ELABORATE THE FOLLOWING CALCULATED DATA OUTPUT**

- **WUE**

Where:

Capacity depends on instant values on fluid flow, temperature and glycol percentage (necessary to set on unit control)

**EER:** is a ration instant Total Capacity and instant Total Electrical Power Consumption readings (in the same time period)

$$\text{pPUE} = [(1) + (1/\text{EER})]$$

**WUE** = (adiabatic water meter flow instant) / (instant total Capacity) [lt/(h\*KW)] with instant readings in the same time period.

**All data outputs are calculated using instant values and also the site operating conditions cannot ensure stable measurements, whereby they can provide only an indicative value. These values must not be considered valid as official performance measurements due to conditions of measurement and precision of the instruments which are different from laboratory measurement conditions and instruments.**

**Tab. 1 - Electrical characteristics**
**Tab. 1a - Electrical data - FD4 088-160**

Models FD4		088 <sup>(3)</sup>	102	117	130	145	160	10X
Power supply	V/Ph/Hz	400V / 3Ph + PE / 50Hz						
Total input power <sup>(1)</sup>	kW	229	262	304	340	386	465	262
OA <sup>(1)</sup> (without PFC)	A	402	442	504	565	635	763	442
cos $\phi$ <sup>(1)</sup> (without PFC)		0,82	0,86	0,87	0,87	0,88	0,88	0,86
Total input power (2)	kW	227	261	302	338	384	463	261
OA <sup>(2)</sup> (without PFC)	A	400	440	502	562	632	760	440
cos $\phi$ <sup>(2)</sup> (without PFC)		0,82	0,86	0,87	0,87	0,88	0,88	0,86
OA <sup>(1)</sup> (with PFC)	A	348	406	470	516	587	714	406
cos $\phi$ <sup>(1)</sup> (with PFC)		0,95	0,93	0,93	0,95	0,95	0,94	0,93
OA <sup>(2)</sup> (with PFC)	A	346	404	467	513	584	711	404
cos $\phi$ <sup>(2)</sup> (with PFC)		0,95	0,93	0,93	0,95	0,95	0,94	0,93
Max. power input	kW	411	537	560	616	616	720	537
FLA	A	679	807	915	984	984	1216	807
cos $\phi$ (without PFC)		0,87	0,96	0,88	0,90	0,90	0,85	0,96
FLA (with PFC)	A	628	788	880	938	939	1157	788
cos $\phi$ (with PFC)		0,95	0,98	0,92	0,95	0,95	0,90	0,98
LRA (Y/D)	A	1126	1023	1145	1339	1339	1567	1023
Max. fuse (gG/aM)	A	800gG/	1000gG/ 1000aM	1250gG/ 1250aM	1250gG/ 1250aM	1250gG/ 1250aM	1250gG/ 1250aM	1000gG/ 1000aM
Ring terminals with hole/Line Helical fixing	mm/Nm	M12 / 50-75Nm	M12 / 50-75Nm	M12 / 50-75Nm	M12x2 / 50-75Nm	M12x2 / 50-75Nm	M12x2 / 50-75Nm	M12 / 50-75Nm
"Control power supply (only for option Fast-Start)"	V/Ph/Hz	230V / 1Ph + N + PE / 50Hz						
Pmax	kW	0,59						
Imax	A	2,3						
FLA	A	7						
Cable section min./max.	mm <sup>2</sup>	1,5 / 35						
Max. fuse (gG/aM)	A	40						
Line Helical fixing	Nm	2						
Compressor - Power input	kW	197	227	264	295	341	420	227
Compressor - Nominal current	A	354	387	442	496	566	694	387
Single compressor 1 - Max. current	A	310	370	420	450	450	566	370
Single compressor 1 - LRA	A	757	586	650	805	805	917	586
Single compressor 2 - Max. current	A	310	370	420	450	450	566	370
Single compressor 2 - LRA	A	757	586	650	805	805	917	586
Fans number	-	14	16	18	20	20	20	20
Fans EC Ø800 - Power input	kW	2,2						
Fans EC Ø800 - Nominal current	A	3,5						
Fans EC Ø800 - Max. current	A	4,2						
Fans EC Ø900 - Power input	kW	2,1						
Fans EC Ø900 - Nominal current	A	3,3						
Fans EC Ø900 - Max. current	A	4,9						
Std. head pressure pump model (option)	-	NB65- 160/173	NB80- 160/161	NB80- 160/161	NB80- 160/161	NB100- 160/169	NB100- 160/176	NB80- 160/161
Std. head pressure pump - Nominal power	kW	15	18,5	18,5	18,5	30	37	18,5
Std. head pressure pump - Motor power	kW	16,6	20,1	20,1	20,1	31,7	38,9	20,1
Std. head pressure pump - Max. current	A	26,3	31,5	31,5	31,5	56,0	68,0	31,5
Std. head pressure pump - LRA	A	184	221	221	221	370	456	221
High head pressure pump model (option)	-	NB65- 160/177	NB80- 160/167	NB80- 160/167	NB80- 160/167	NB100- 200/181	NB100- 200/192	NB80- 160/167
High head pressure pump - Nominal power	kW	18,5	22	22	22	37	45	22
High head pressure pump - Motor power	kW	20	23,4	23,4	23,4	38,9	48,0	23,4
High head pressure pump - Max. current	A	31,5	38,0	38,0	38,0	68,0	82,0	38,0
Std. head pressure pump - LRA	A	221	274	274	274	456	566	274

(1) Fans EC Ø800

(2) Fans EC Ø900

(3) Compressor part winding

Smart-Aisle™ Application - Outdoor temperature 35° C; fluid inlet/outlet temperature 26/20° C; 70-30% water-glycol mixture; R134a refrigerant (with R513A refrigerant indicated values are increased by 3%); System adiabatic OFF.

The cables have to be sized in compliance with local standards and according to the type and characteristics of installation and FLA current.

OA, FLA, LRA are calculated for unit without pumps.

If the unit with EC-FAN or inverter pump is connected to an electric installation where an earthleakage circuit breaker (ELCB) is used as additional protection, the circuit breaker must be of a type marked with the followings symbols (This circuit breaker is type B.) :



**Tab. 1b - Electrical data - FD4 LN 088-160**

Models FD4 LN		088 <sup>(3)</sup>	102	117	130	145	160	10X
Power supply	V/Ph/Hz	400V / 3Ph + PE / 50Hz						
Total input power <sup>(1)</sup>	kW	229	262	287	341	395	480	262
OA <sup>(1)</sup> (without PFC)	A	401	439	477	565	645	783	439
cosφ <sup>(1)</sup> (without PFC)		0,82	0,86	0,87	0,87	0,88	0,88	0,86
Total input power <sup>(2)</sup>	kW	225	257	281	335	389	474	257
OA <sup>(2)</sup> (without PFC)	A	396	433	471	558	638	776	433
cosφ <sup>(2)</sup> (without PFC)		0,82	0,86	0,86	0,87	0,88	0,88	0,86
OA <sup>(1)</sup> (with PFC)	A	348	404	443	517	598	735	404
cosφ <sup>(1)</sup> (with PFC)		0,95	0,94	0,93	0,95	0,95	0,94	0,94
OA <sup>(2)</sup> (with PFC)	A	342	397	436	509	590	727	397
cosφ <sup>(2)</sup> (with PFC)		0,95	0,93	0,93	0,95	0,95	0,94	0,93
Max. power input	kW	411	537	560	616	616	720	537
FLA	A	679	807	915	984	984	1216	807
cosφ (without PFC)		0,87	0,96	0,88	0,90	0,90	0,85	0,96
FLA (with PFC)	A	628	788	880	938	939	1157	788
cosφ (with PFC)		0,95	0,98	0,92	0,95	0,95	0,90	0,98
LRA (Y/D)	A	1126	1023	1145	1339	1339	1567	1023
Max. fuse (gG/aM)	A	800gG/	1000gG/ 1000aM	1250gG/ 1250aM	1250gG/ 1250aM	1250gG/ 1250aM	1250gG/ 1250aM	1000gG/ 1000aM
Ring terminals with hole/Line Helical fixing	mm/Nm	M12 / 50-75Nm	M12 / 50-75Nm	M12 / 50-75Nm	M12x2 / 50-75Nm	M12x2 / 50-75Nm	M12x2 / 50-75Nm	M12 / 50-75Nm
"Control power supply (only for option Fast-Start)"	V/Ph/Hz	230V / 1Ph + N + PE / 50Hz						
Pmax	kW	0,59						
Imax	A	2,3						
FLA	A	7						
Cable section min./max.	mm <sup>2</sup>	1,5 / 35						
Max. fuse (gG/aM)	A	40						
Line Helical fixing	Nm	2						
Compressor - Power input	kW	211	241	264	315	369	454	241
Compressor - Nominal current	A	374	408	442	526	606	744	408
Single compressor 1 - Max. current	A	310	370	420	450	450	566	370
Single compressor 1 - LRA	A	757	586	650	805	805	917	586
Single compressor 2 - Max. current	A	310	370	420	450	450	566	370
Single compressor 2 - LRA	A	757	586	650	805	805	917	586
Fans number	-	14	16	18	20	20	20	20
Fans EC Ø800 - Power input	kW	1,3						
Fans EC Ø800 - Nominal current	A	2,0						
Fans EC Ø800 - Max. current	A	4,2						
Fans EC Ø900 - Power input	kW	1,0						
Fans EC Ø900 - Nominal current	A	1,6						
Fans EC Ø900 - Max. current	A	4,9						
Std. head pressure pump model (option)	-	NB65- 160/173	NB80- 160/161	NB80- 160/161	NB80- 160/161	NB100- 160/169	NB100- 160/176	NB80- 160/161
Std. head pressure pump - Nominal power	kW	15	18,5	18,5	18,5	30	37	18,5
Std. head pressure pump - Motor power	kW	16,4	20,1	20,1	20,1	31,7	38,9	20,1
Std. head pressure pump - Max. current	A	26,3	31,5	31,5	31,5	56,0	68,0	31,5
Std. head pressure pump - LRA	A	184	221	221	221	370	456	221
High head pressure pump model (option)	-	NB65- 160/177	NB80- 160/167	NB80- 160/167	NB80- 160/167	NB100- 200/181	NB100- 200/192	NB80- 160/167
High head pressure pump - Nominal power	kW	18,5	22	22	22	37	45	22
High head pressure pump - Motor power	kW	20	23,4	23,4	23,4	38,9	48,0	23,4
High head pressure pump - Max. current	A	31,5	38,0	38,0	38,0	68,0	82,0	38,0
Std. head pressure pump - LRA	A	221	274	274	274	456	566	274

(1) Fans EC Ø800

(2) Fans EC Ø900

(3) Compressor part winding

Smart-Aisle™ Application - Outdoor temperature 35° C; fluid inlet/outlet temperature 26/20° C; 70-30% water-glycol mixture; R134a refrigerant (with R513A refrigerant indicated values are increased by 3%); System adiabatic OFF.

The cables have to be sized in compliance with local standards and according to the type and characteristics of installation and FLA current.

OA, FLA, LRA are calculated for unit without pumps.

If the unit with EC-FAN or inverter pump is connected to an electric installation where an earthleakage circuit breaker (ELCB) is used as additional protection, the circuit breaker must be of a typ marked with the followings symbols (This circuit breaker is type B.) :

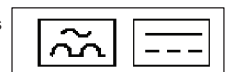

**Tab. 1c - Electrical data - FA4 088-160**

Models FA4		088 <sup>(3)</sup>	102	117	130	145	160	10X
Power supply	V/Ph/Hz	400V / 3Ph + PE / 50Hz						
Total input power <sup>(1)</sup>	kW	231	265	307	343	391	471	265
OA <sup>(1)</sup> (without PFC)	A	406	446	509	571	641	771	446
cosφ <sup>(1)</sup> (without PFC)		0,82	0,86	0,87	0,87	0,88	0,88	0,86
Total input power <sup>(2)</sup>	kW	232	266	308	344	392	472	266
OA <sup>(2)</sup> (without PFC)	A	407	447	510	572	642	772	447
cosφ <sup>(2)</sup> (without PFC)		0,82	0,86	0,87	0,87	0,88	0,88	0,86
OA <sup>(1)</sup> (with PFC)	A	352	410	474	521	594	722	410
cosφ <sup>(1)</sup> (with PFC)		0,95	0,93	0,93	0,95	0,95	0,94	0,93
OA <sup>(2)</sup> (with PFC)	A	353	411	476	523	595	724	411
cosφ <sup>(2)</sup> (with PFC)		0,95	0,93	0,93	0,95	0,95	0,94	0,93
Max. power input	kW	411	537	560	616	616	720	537
FLA	A	679	807	915	984	984	1216	807
cosφ (without PFC)		0,87	0,96	0,88	0,90	0,90	0,85	0,96
FLA (with PFC)	A	628	788	880	938	939	1157	788
cosφ (with PFC)		0,95	0,98	0,92	0,95	0,95	0,90	0,98
LRA (Y/D)	A	1126	1023	1145	1339	1339	1567	1023
Max. fuse (gG/aM)	A	800gG/	1000gG/ 1000aM	1250gG/ 1250aM	1250gG/ 1250aM	1250gG/ 1250aM	1250gG/ 1250aM	1000gG/ 1000aM
Ring terminals with hole/Line Helical fixing	mm/Nm	M12 / 50- 75Nm	M12 / 50- 75Nm	M12 / 50- 75Nm	M12x2 / 50-75Nm	M12x2 / 50-75Nm	M12x2 / 50-75Nm	M12 / 50- 75Nm
"Control power supply (only for option Fast-Start)"	V/Ph/Hz	230V / 1Ph + N + PE / 50Hz						
Pmax	kW	0,59						
Imax	A	2,3						
FLA	A	7						
Cable section min./max.	mm <sup>2</sup>	1,5 / 35						
Max. fuse (gG/aM)	A	40						
Line Helical fixing	Nm	2						
Compressor - Power input	kW	200	229	266	298	346	426	229
Compressor - Nominal current	A	358	390	447	502	572	702	390
Single compressor 1 - Max. current	A	310	370	420	450	450	566	370
Single compressor 1 - LRA	A	757	586	650	805	805	917	586
Single compressor 2 - Max. current	A	310	370	420	450	450	566	370
Single compressor 2 - LRA	A	757	586	650	805	805	917	586
Fans number	-	14	16	18	20	20	20	20
Fans EC Ø800 - Power input	kW	2,2						
Fans EC Ø800 - Nominal current	A	3,5						
Fans EC Ø800 - Max. current	A	4,2						
Fans EC Ø900 - Power input	kW	2,3						
Fans EC Ø900 - Nominal current	A	3,5						
Fans EC Ø900 - Max. current	A	3,8						
Std. head pressure pump model (option)	-	NB65- 160/173	NB80- 160/161	NB80- 160/161	NB80- 160/161	NB100- 160/169	NB100- 160/176	NB80- 160/161
Std. head pressure pump - Nominal power	kW	15	18,5	18,5	18,5	30	37	18,5
Std. head pressure pump - Motor power	kW	16,4	20,1	20,1	20,1	31,7	38,9	20,1
Std. head pressure pump - Max. current	A	26,3	31,5	31,5	31,5	56,0	68,0	31,5
Std. head pressure pump - LRA	A	184	221	221	221	370	456	221
High head pressure pump model (option)	-	NB65- 160/177	NB80- 160/167	NB80- 160/167	NB80- 160/167	NB100- 200/181	NB100- 200/192	NB80- 160/167
High head pressure pump - Nominal power	kW	18,5	22	22	22	37	45	22
High head pressure pump - Motor power	kW	20	23,4	23,4	23,4	38,9	48,0	23,4
High head pressure pump - Max. current	A	31,5	38,0	38,0	38,0	68,0	82,0	38,0
Std. head pressure pump - LRA	A	221	274	274	274	456	566	274
Adiabatic pumps model (option)	-	GXR13	GXR13	GXR13	GXR13	GXR13	GXR13	GXR13
Adiabatic pumps - Number	-	4	4	4	4	4	4	4
Adiabatic pumps - Nominal power	kW	0,45	0,45	0,45	0,45	0,45	0,45	0,45
Adiabatic pumps - Motor power	kW	0,95	0,95	0,95	0,95	0,95	0,95	0,95
Adiabatic pumps - Max. current	A	1,6	1,6	1,6	1,6	1,6	1,6	1,6
Adiabatic pumps pump - LRA	A	-						

(1) Fans EC Ø800

(2) Fans EC Ø900

(3) Compressor part winding

Smart-Aisle™ Application - Outdoor temperature 35° C; fluid inlet/outlet temperature 26/20° C; 70-30% water-glycol mixture; R134a refrigerant (with R513A refrigerant indicated values are increased by 3%); System adiabatic OFF. The cables have to be sized in compliance with local standards and according to the type and characteristics of installation and FLA current. OA, FLA, LRA are calculated for unit without pumps.

If the unit with EC-FAN or inverter pump is connected to an electric installation where an earthleakage circuit breaker (ELCB) is used as additional protection, the circuit breaker must be of a type marked with the followings symbols (This circuit breaker is type B.):



**Tab. 1d - Electrical data - FA4 LN 088-160**

Models FA4 LN		088 <sup>(3)</sup>	102	117	130	145	160	10X
Power supply	V/Ph/Hz	400V / 3Ph + PE / 50Hz						
Total input power <sup>(1)</sup>	kW	232	265	307	346	402	488	265
OA <sup>(1)</sup> (without PFC)	A	405	444	508	573	655	795	444
cosφ <sup>(1)</sup> (without PFC)		0,83	0,86	0,87	0,87	0,89	0,89	0,86
Total input power <sup>(2)</sup>	kW	229	262	303	341	397	483	262
OA <sup>(2)</sup> (without PFC)	A	402	440	503	568	650	790	440
cosφ <sup>(2)</sup> (without PFC)		0,82	0,86	0,87	0,87	0,88	0,88	0,86
OA <sup>(1)</sup> (with PFC)	A	352	409	474	525	609	747	409
cosφ <sup>(1)</sup> (with PFC)		0,95	0,94	0,94	0,95	0,95	0,94	0,94
OA <sup>(2)</sup> (with PFC)	A	348	405	469	519	603	741	405
cosφ <sup>(2)</sup> (with PFC)		0,95	0,93	0,93	0,95	0,95	0,94	0,93
Max. power input	kW	411	537	560	616	616	720	537
FLA	A	679	807	915	984	984	1216	807
cosφ (without PFC)		0,87	0,96	0,88	0,90	0,90	0,85	0,96
FLA (with PFC)	A	628	788	880	938	939	1157	788
cosφ (with PFC)		0,95	0,98	0,92	0,95	0,95	0,90	0,98
LRA (Y/D)	A	1126	1023	1145	1339	1339	1567	1023
Max. fuse (gG/aM)	A	800gG/	1000gG/ 1000aM	1250gG/ 1250aM	1250gG/ 1250aM	1250gG/ 1250aM	1250gG/ 1250aM	1000gG/ 1000aM
Ring terminals with hole/Line Helical fixing	mm/Nm	M12 / 50-75Nm	M12 / 50-75Nm	M12 / 50-75Nm	M12x2 / 50-75Nm	M12x2 / 50-75Nm	M12x2 / 50-75Nm	M12 / 50-75Nm
"Control power supply(only for option Fast-Start)"	V/Ph/Hz	230V / 1Ph + N + PE / 50Hz						
Pmax	kW	0,59						
Imax	A	2,3						
FLA	A	7						
Cable section min./max.	mm <sup>2</sup>	1,5 / 35						
Max. fuse (gG/aM)	A	40						
Line Helical fixing	Nm	2						
Compressor - Power input	kW	214	245	284	320	376	462	245
Compressor - Nominal current	A	378	413	473	534	616	756	413
Single compressor 1 - Max. current	A	310	370	420	450	450	566	370
Single compressor 1 - LRA	A	757	586	650	805	805	917	586
Single compressor 2 - Max. current	A	310	370	420	450	450	566	370
Single compressor 2 - LRA	A	757	586	650	805	805	917	586
Fans number	-	14	16	18	20	20	20	20
Fans EC Ø800 - Power input	kW	1,3						
Fans EC Ø800 - Nominal current	A	2,0						
Fans EC Ø800 - Max. current	A	4,2						
Fans EC Ø900 - Power input	kW	1,1						
Fans EC Ø900 - Nominal current	A	1,7						
Fans EC Ø900 - Max. current	A	3,8						
Std. head pressure pump model (option)	-	NB65- 160/173	NB80- 160/161	NB80- 160/161	NB80- 160/161	NB100- 160/169	NB100- 160/176	NB80- 160/161
Std. head pressure pump - Nominal power	kW	15	18,5	18,5	18,5	30	37	18,5
Std. head pressure pump - Motor power	kW	16,4	20,1	20,1	20,1	31,7	38,9	20,1
Std. head pressure pump - Max. current	A	26,3	31,5	31,5	31,5	56,0	68,0	31,5
Std. head pressure pump - LRA	A	184	221	221	221	370	456	221
High head pressure pump model (option)	-	NB65- 160/177	NB80- 160/167	NB80- 160/167	NB80- 160/167	NB100- 200/181	NB100- 200/192	NB80- 160/167
High head pressure pump - Nominal power	kW	18,5	22	22	22	45	45	22
High head pressure pump - Motor power	kW	20	23,4	23,4	23,4	38,9	48,0	23,4
High head pressure pump - Max. current	A	31,5	38,0	38,0	38,0	68,0	82,0	38,0
Std. head pressure pump - LRA	A	221	274	274	274	456	566	274
Adiabatic pumps model (option)	-	GXR13	GXR13	GXR13	GXR13	GXR13	GXR13	GXR13
Adiabatic pumps - Number	-	4	4	4	4	4	4	4
Adiabatic pumps - Nominal power	kW	0,45	0,45	0,45	0,45	0,45	0,45	0,45
Adiabatic pumps - Motor power	kW	0,95	0,95	0,95	0,95	0,95	0,95	0,95
Adiabatic pumps - Max. current	A	1,6	1,6	1,6	1,6	1,6	1,6	1,6
Adiabatic pumps pump - LRA	A	-						

(1) Fans EC Ø800

(2) Fans EC Ø900

(3) Compressor part winding

Smart-Aisle™ Application - Outdoor temperature 35° C; fluid inlet/outlet temperature 26/20° C; 70-30% water-glycol mixture; R134a refrigerant (with R513A refrigerant indicated values are increased by 3%); System adiabatic OFF. The cables have to be sized in compliance with local standards and according to the type and characteristics of installation and FLA current.

OA, FLA, LRA are calculated for unit without pumps.

If the unit with EC-FAN or inverter pump is connected to an electric installation where an earthleakage circuit breaker (ELCB) is used as additional protection, the circuit breaker must be of a type marked with the followings symbols (This circuit breaker is type B.) :

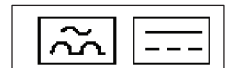

**Tab. 1e - Electrical data - FDL 077-138**

Models FDL		077	089	101	116	127	138
Power supply	V/Ph/Hz	400V / 3Ph + PE / 50Hz					
Total input power <sup>(1)</sup>	kW	244	277	328	373	421	452
OA <sup>(1)</sup> (without PFC)	A	400	446	538	608	686	742
cosφ <sup>(1)</sup> (without PFC)		0,88	0,90	0,88	0,88	0,89	0,88
Total input power <sup>(2)</sup>	kW	239	272	323	366	414	444
OA <sup>(2)</sup> (without PFC)	A	393	439	530	598	675	730
cosφ <sup>(2)</sup> (without PFC)		0,88	0,90	0,88	0,88	0,88	0,88
OA <sup>(1)</sup> (with PFC)	A	375	423	505	568	646	693
cosφ <sup>(1)</sup> (with PFC)		0,94	0,95	0,94	0,95	0,94	0,94
OA <sup>(2)</sup> (with PFC)	A	368	416	496	558	635	681
cosφ <sup>(2)</sup> (with PFC)		0,94	0,95	0,94	0,95	0,94	0,94
Max. power input <sup>(2)</sup>	kW	348	388	453	495	566	618
FLA <sup>(2)</sup>	A	619	679	709	799	915	993
cosφ (without PFC) <sup>(2)</sup>		0,81	0,83	0,92	0,89	0,89	0,90
FLA (with PFC) <sup>(2)</sup>	A	585	801	893	953	954	1172
cosφ (with PFC) <sup>(2)</sup>		0,86	0,70	0,73	0,75	0,86	0,76
LRA (Y/D) <sup>(2)</sup>	A	775	1035	1159	1354	1354	1582
Max. fuse (gG/aM) <sup>(2)</sup>	A	800gG/	1000gG/ 1000aM	1000gG/ 1000aM	1250gG/ 1250aM	1250gG/ 1250aM	1250gG/ 1250aM
Ring terminals with hole/Line Helical fixing <sup>(2)</sup>	mm/Nm	M12 / 50-75Nm	M12 / 50-75Nm	M12 / 50-75Nm	M12 / 50-75Nm	M12 / 50-75Nm	M12x2 / 50-75Nm
"Control power supply (only for option Fast-Start)"	V/Ph/Hz	230V / 1Ph + N + PE / 50Hz					
Pmax	kW	0,59					
Imax	A	2,3					
FLA	A	7					
Cable section min./max.	mm <sup>2</sup>	1,5 / 35					
Max. fuse (gG/aM)	A	40					
Line Helical fixing	Nm	2					
Compressor - Power input	kW	213	246	292	331	374	400
Compressor - Nominal current	A	352	398	482	544	614	662
Single compressor 1 - Max. current	A	280	310	320	360	413	447
Single compressor 1 - LRA	A	436	465	586	650	805	917
Single compressor 2 - Max. current	A	280	310	320	360	413	447
Single compressor 2 - LRA	A	436	465	586	650	805	917
Fans number	-	12	12	14	16	18	20
Fans EC Ø800 - Power input	kW	2,6					
Fans EC Ø800 - Nominal current	A	4,0					
Fans EC Ø800 - Max. current	A	4,2					
Fans EC Ø900 - Power input	kW	2,2					
Fans EC Ø900 - Nominal current	A	3,4					
Fans EC Ø900 - Max. current	A	4,9					
Std. head pressure pump model (option)	-	NB65- 160/173	NB80- 160/161	NB80- 160/161	NB80- 160/161	NB100- 160/169	NB100- 160/176
Std. head pressure pump - Nominal power	kW	15	18,5	18,5	18,5	30	37
Std. head pressure pump - Motor power	kW	16,4	20,1	20,1	20,1	31,7	38,9
Std. head pressure pump - Max. current	A	26,3	31,5	31,5	31,5	56,0	68,0
Std. head pressure pump - LRA	A	184	221	221	221	370	456
High head pressure pump model (option)	-	NB65- 160/177	NB80- 160/167	NB80- 160/167	NB80- 160/167	NB100- 200/181	NB100- 200/192
High head pressure pump - Nominal power	kW	18,5	22	22	22	37	45
High head pressure pump - Motor power	kW	20	23,4	23,4	23,4	38,9	48,0
High head pressure pump - Max. current	A	31,5	38,0	38,0	38,0	68,0	82,0
Std. head pressure pump - LRA	A	221	274	274	274	456	566

(1) Fans EC Ø800

(2) Fans EC Ø900

Legacy Application - Outdoor temperature 35° C; fluid inlet/outlet temperature 15/10° C; 70-30% water-glycol mixture; R134A refrigerant (with R513A refrigerant indicated values are increased by 3%). The cables have to be sized in compliance with local standards and according to the type and characteristics of installation and FLA current.

OA, FLA, LRA are calculated for unit without pumps.

If the unit with EC-FAN or inverter pump is connected to an electric installation where an earthleakage circuit breaker (ELCB) is used as additional protection, the circuit breaker must be of a type marked with the followings symbols (This circuit breaker is type B.) :

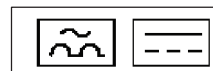

**Tab. 1f - Electrical data - FDL LN 077-138**

Models FDL LN		077	089	101	116	127	138
Power supply	V/Ph/Hz	400V / 3Ph + PE / 50Hz					
Total input power <sup>(1)</sup>	kW	243	278	333	377	423	452
OA <sup>(1)</sup> (without PFC)	A	397	449	545	614	688	744
cosφ <sup>(1)</sup> (without PFC)		0,89	0,90	0,88	0,89	0,89	0,88
Total input power <sup>(2)</sup>	kW	241	276	330	374	419	448
OA (2) (without PFC)	A	394	446	542	611	685	740
cosφ (2) (without PFC)		0,88	0,89	0,88	0,88	0,88	0,87
OA (1) (with PFC)	A	373	425	512	575	648	694
cosφ <sup>(1)</sup> (with PFC)		0,94	0,94	0,94	0,95	0,94	0,94
OA <sup>(2)</sup> (with PFC)	A	370	423	508	571	644	689
cosφ <sup>(2)</sup> (with PFC)		0,94	0,94	0,94	0,94	0,94	0,94
Max. power input <sup>(2)</sup>	kW	348	388	453	495	566	618
FLA <sup>(2)</sup>	A	619	679	709	799	915	993
cosφ (without PFC) <sup>(2)</sup>		0,81	0,83	0,92	0,89	0,89	0,90
FLA (with PFC) <sup>(2)</sup>	A	585	801	893	953	954	1172
cosφ (with PFC) <sup>(2)</sup>		0,86	0,70	0,73	0,75	0,86	0,76
LRA (Y/D) <sup>(2)</sup>	A	775	1035	1159	1354	1354	1582
Max. fuse (gG/aM) <sup>(2)</sup>	A	800gG/	1000gG/ 1000aM	1000gG/ 1000aM	1250gG/ 1250aM	1250gG/ 1250aM	1250gG/ 1250aM
Ring terminals with hole/Line Helical fixing <sup>(2)</sup>	mm/Nm	M12 / 50-75Nm	M12 / 50-75Nm	M12 / 50-75Nm	M12 / 50-75Nm	M12 / 50-75Nm	M12x2 / 50-75Nm
"Control power supply (only for option Fast-Start)"	V/Ph/Hz	230V / 1Ph + N + PE / 50Hz					
Pmax	kW	0,59					
Imax	A	2,3					
FLA	A	7					
Cable section min./max.	mm <sup>2</sup>	1,5 / 35					
Max. fuse (gG/aM)	A	40					
Line Helical fixing	Nm	2					
Compressor - Power input	kW	229	264	316	358	401	428
Compressor - Nominal current	A	374	426	518	584	654	706
Single compressor 1 - Max. current	A	280	310	320	360	413	447
Single compressor 1 - LRA	A	436	465	586	650	805	917
Single compressor 2 - Max. current	A	280	310	320	360	413	447
Single compressor 2 - LRA	A	436	465	586	650	805	917
Fans number	-	12	12	14	16	18	20
Fans EC Ø800 - Power input	kW	1,2					
Fans EC Ø800 - Nominal current	A	1,9					
Fans EC Ø800 - Max. current	A	4,2					
Fans EC Ø900 - Power input	kW	1,0					
Fans EC Ø900 - Nominal current	A	1,7					
Fans EC Ø900 - Max. current	A	4,9					
Std. head pressure pump model (option)	-	NB65- 160/173	NB80- 160/161	NB80- 160/161	NB80- 160/161	NB100- 160/169	NB100- 160/176
Std. head pressure pump - Nominal power	kW	15	18,5	18,5	18,5	30	37
Std. head pressure pump - Motor power	kW	16,4	20,1	20,1	20,1	31,7	38,9
Std. head pressure pump - Max. current	A	26,3	31,5	31,5	31,5	56,0	68,0
Std. head pressure pump - LRA	A	184	221	221	221	370	456
High head pressure pump model (option)	-	NB65- 160/177	NB80- 160/167	NB80- 160/167	NB80- 160/167	NB100- 200/181	NB100- 200/192
High head pressure pump - Nominal power	kW	18,5	22	22	22	37	45
High head pressure pump - Motor power	kW	20	23,4	23,4	23,4	38,9	48,0
High head pressure pump - Max. current	A	31,5	38,0	38,0	38,0	68,0	82,0
Std. head pressure pump - LRA	A	221	274	274	274	456	566

(1) Fans EC Ø800

(2) Fans EC Ø900

Legacy Application - Outdoor temperature 35° C; fluid inlet/outlet temperature 15/10° C; 70-30% water-glycol mixture; R134A refrigerant (with R513A refrigerant indicated values are increased by 3%). The cables have to be sized in compliance with local standards and according to the type and characteristics of installation and FLA current.

OA, FLA, LRA are calculated for unit without pumps.

If the unit with EC-FAN or inverter pump is connected to an electric installation where an earthleakage circuit breaker (ELCB) is used as additional protection, the circuit breaker must be of a type marked with the followings symbols (This circuit breaker is type B.) :

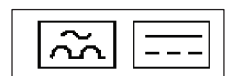

**Tab. 1g - Electrical data - FAL 077-138**

Models FAL		077	089	101	116	127	138
Power supply	V/Ph/Hz	400V / 3Ph + PE / 50Hz					
Total input power <sup>(1)</sup>	kW	249	282	334	379	427	459
OA <sup>(1)</sup> (without PFC)	A	404	450	546	614	694	750
cosφ <sup>(1)</sup> (without PFC)		0,89	0,90	0,88	0,89	0,89	0,88
Total input power <sup>(2)</sup>	kW	245	278	330	374	422	453
OA <sup>(2)</sup> (without PFC)	A	399	445	540	608	687	742
cosφ <sup>(2)</sup> (without PFC)		0,89	0,90	0,88	0,89	0,89	0,88
OA <sup>(1)</sup> (with PFC)	A	380	428	513	575	648	702
cosφ <sup>(1)</sup> (with PFC)		0,94	0,95	0,94	0,95	0,95	0,94
OA <sup>(2)</sup> (with PFC)	A	375	423	507	569	640	693
cosφ <sup>(2)</sup> (with PFC)		0,94	0,95	0,94	0,95	0,95	0,94
Max. power input <sup>(2)</sup>	kW	348	388	453	495	566	618
FLA <sup>(2)</sup>	A	606	666	693	781	894	970
cosφ (without PFC) <sup>(2)</sup>		0,83	0,84	0,94	0,92	0,91	0,92
FLA (with PFC) <sup>(2)</sup>	A	572	801	893	953	954	1172
cosφ (with PFC) <sup>(2)</sup>		0,88	0,70	0,73	0,75	0,86	0,76
LRA (Y/D) <sup>(2)</sup>	A	762	1035	1159	1354	1354	1582
Max. fuse (gG/aM) <sup>(2)</sup>	A	800gG/	1000gG/ 1000aM	1000gG/ 1000aM	1250gG/ 1250aM	1250gG/ 1250aM	1250gG/ 1250aM
Ring terminals with hole/Line Helical fixing <sup>(2)</sup>	mm/Nm	M12 / 50-75Nm	M12 / 50-75Nm	M12 / 50-75Nm	M12 / 50-75Nm	M12 / 50-75Nm	M12x2 / 50-75Nm
"Control power supply (only for option Fast-Start)"	V/Ph/Hz	230V / 1Ph + N + PE / 50Hz					
Pmax	kW	0,59					
Imax	A	2,3					
FLA	A	7					
Cable section min./max.	mm <sup>2</sup>	1,5 / 35					
Max. fuse (gG/aM)	A	40					
Line Helical fixing	Nm	2					
Compressor - Power input	kW	216,2	250	296	336	378,6	404,7
Compressor - Nominal current	A	356	402	490	550	622	670
Single compressor 1 - Max. current	A	280	310	320	360	413	447
Single compressor 1 - LRA	A	436	465	586	650	805	917
Single compressor 2 - Max. current	A	280	310	320	360	413	447
Single compressor 2 - LRA	A	436	465	586	650	805	917
Fans number	-	12	12	14	16	18	20
Fans EC Ø800 - Power input	kW	2,7					
Fans EC Ø800 - Nominal current	A	4,0					
Fans EC Ø800 - Max. current	A	4,2					
Fans EC Ø900 - Power input	kW	2,4					
Fans EC Ø900 - Nominal current	A	3,6					
Fans EC Ø900 - Max. current	A	3,8					
Std. head pressure pump model (option)	-	NB65- 160/173	NB80- 160/161	NB80- 160/161	NB80- 160/161	NB100- 160/169	NB100- 160/176
Std. head pressure pump - Nominal power	kW	15	18,5	18,5	18,5	30	37
Std. head pressure pump - Motor power	kW	16,4	20,1	20,1	20,1	31,7	38,9
Std. head pressure pump - Max. current	A	26,3	31,5	31,5	31,5	56,0	68,0
Std. head pressure pump - LRA	A	184	221	221	221	370	456
High head pressure pump model (option)	-	NB65- 160/177	NB80- 160/167	NB80- 160/167	NB80- 160/167	NB100- 200/181	NB100- 200/192
High head pressure pump - Nominal power	kW	18,5	22	22	22	37	45
High head pressure pump - Motor power	kW	20	23,4	23,4	23,4	38,9	48,0
High head pressure pump - Max. current	A	31,5	38,0	38,0	38,0	68,0	82,0
Std. head pressure pump - LRA	A	221	274	274	274	456	566
Adiabatic pumps model (option)	-	GXR13	GXR13	GXR13	GXR13	GXR13	GXR13
Adiabatic pumps - Number	-	4	4	4	4	4	4
Adiabatic pumps - Nominal power	kW	0,45	0,45	0,45	0,45	0,45	0,45
Adiabatic pumps - Motor power	kW	0,95	0,95	0,95	0,95	0,95	0,95
Adiabatic pumps - Max. current	A	1,6	1,60	1,60	1,60	1,60	1,60
Adiabatic pumps pump - LRA	A	-					

(1) Fans EC Ø800

(2) Fans EC Ø900

Legacy Application - Outdoor temperature 35° C; fluid inlet/outlet temperature 15/10° C; 70-30% water-glycol mixture; R134A refrigerant (with R513A refrigerant indicated values are increased by 3%); System adiabatic OFF. The cables have to be sized in compliance with local standards and according to the type and characteristics of installation and FLA current.

OA, FLA, LRA are calculated for unit without pumps.

If the unit with EC-FAN or inverter pump is connected to an electric installation where an earthleakage circuit breaker (ELCB) is used as additional protection, the circuit breaker must be of a type marked with the followings symbols (This circuit breaker is type B.) :

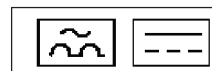

**Tab. 1h - Electrical data - FAL LN 077-138**

Models FAL LN		077	089	101	116	127	138
Power supply	V/Ph/Hz	400V / 3Ph + PE / 50Hz					
Total input power <sup>(1)</sup>	kW	247	283	338	383	429	459
OA <sup>(1)</sup> (without PFC)	A	403	455	555	624	698	754
cosφ <sup>(1)</sup> (without PFC)		0,89	0,90	0,88	0,89	0,89	0,88
Total input power <sup>(2)</sup>	kW	246	282	337	382	427	457
OA <sup>(2)</sup> (without PFC)	A	402	454	553	623	696	752
cosφ <sup>(2)</sup> (without PFC)		0,88	0,90	0,88	0,88	0,89	0,88
OA <sup>(1)</sup> (with PFC)	A	379	432	521	585	651	705
cosφ <sup>(1)</sup> (with PFC)		0,94	0,95	0,94	0,95	0,95	0,94
OA <sup>(2)</sup> (with PFC)	A	377	431	520	583	649	702
cosφ <sup>(2)</sup> (with PFC)		0,94	0,95	0,93	0,95	0,95	0,94
Max. power input <sup>(2)</sup>	kW	348	388	453	495	566	618
FLA <sup>(2)</sup>	A	606	666	693	781	894	970
cosφ (without PFC) <sup>(2)</sup>		0,83	0,84	0,94	0,92	0,91	0,92
FLA (with PFC) <sup>(2)</sup>	A	572	801	893	953	954	1172
cosφ (with PFC) <sup>(2)</sup>		0,88	0,70	0,73	0,75	0,86	0,76
LRA (Y/D) <sup>(2)</sup>	A	762	1035	1159	1354	1354	1582
Max. fuse (gG/aM) <sup>(2)</sup>	A	800gG/	1000gG/ 1000aM	1000gG/ 1000aM	1250gG/ 1250aM	1250gG/ 1250aM	1250gG/ 1250aM
Ring terminals with hole/Line Helical fixing <sup>(2)</sup>	mm/Nm	M12 / 50-75Nm	M12 / 50-75Nm	M12 / 50-75Nm	M12 / 50-75Nm	M12 / 50-75Nm	M12x2 / 50-75Nm
"Control power supply (only for option Fast-Start)"	V/Ph/Hz	230V / 1Ph + N + PE / 50Hz					
Pmax	kW	0,59					
Imax	A	2,3					
FLA	A	7					
Cable section min./max.	mm <sup>2</sup>	1,5 / 35					
Max. fuse (gG/aM)	A	40					
Line Helical fixing	Nm	2					
Compressor - Power input	kW	232,8	269	321	364	407,4	435,3
Compressor - Nominal current	A	380	432	528	594	664	716
Single compressor 1 - Max. current	A	280	310	320	360	413	447
Single compressor 1 - LRA	A	436	465	586	650	805	917
Single compressor 2 - Max. current	A	280	310	320	360	413	447
Single compressor 2 - LRA	A	436	465	586	650	805	917
Fans number	-	12	12	14	16	18	20
Fans EC Ø800 - Power input	kW	1,2					
Fans EC Ø800 - Nominal current	A	1,9					
Fans EC Ø800 - Max. current	A	4,2					
Fans EC Ø900 - Power input	kW	1,1					
Fans EC Ø900 - Nominal current	A	1,8					
Fans EC Ø900 - Max. current	A	3,8					
Std. head pressure pump model (option)	-	NB65- 160/173	NB80- 160/161	NB80- 160/161	NB80- 160/161	NB100- 160/169	NB100- 160/176
Std. head pressure pump - Nominal power	kW	15	18,5	18,5	18,5	30	37
Std. head pressure pump - Motor power	kW	16,4	20,1	20,1	20,1	31,7	38,9
Std. head pressure pump - Max. current	A	26,3	31,5	31,5	31,5	56,0	68,0
Std. head pressure pump - LRA	A	184	221	221	221	370	456
High head pressure pump model (option)	-	NB65- 160/177	NB80- 160/167	NB80- 160/167	NB80- 160/167	NB100- 200/181	NB100- 200/192
High head pressure pump - Nominal power	kW	18,5	22	22	22	37	45
High head pressure pump - Motor power	kW	20	23,4	23,4	23,4	38,9	48,0
High head pressure pump - Max. current	A	31,5	38,0	38,0	38,0	68,0	82,0
Std. head pressure pump - LRA	A	221	274	274	274	456	566
Adiabatic pumps model (option)	-	GXR13	GXR13	GXR13	GXR13	GXR13	GXR13
Adiabatic pumps - Number	-	4	4	4	4	4	4
Adiabatic pumps - Nominal power	kW	0,45	0,45	0,45	0,45	0,45	0,45
Adiabatic pumps - Motor power	kW	0,95	0,95	0,95	0,95	0,95	0,95
Adiabatic pumps - Max. current	A	1,6	1,60	1,60	1,60	1,60	1,60
Adiabatic pumps pump - LRA	A	-					

(1) Fans EC Ø800

(2) Fans EC Ø900

Legacy Application - Outdoor temperature 35° C; fluid inlet/outlet temperature 15/10° C; 70-30% water-glycol mixture; R134A refrigerant (with R513A refrigerant indicated values are increased by 3%); System adiabatic OFF. The cables have to be sized in compliance with local standards and according to the type and characteristics of installation and FLA current.

OA, FLA, LRA are calculated for unit without pumps.

If the unit with EC-FAN or inverter pump is connected to an electric installation where an earthleakage circuit breaker (ELCB) is used as additional protection, the circuit breaker must be of a type marked with the followings symbols (This circuit breaker is type B.) :

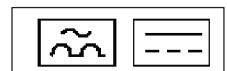

**Tab. 1i - Electrical data - CDL 077-138**

Models CDL		077	089	101	116	127	138
Power supply	V/Ph/Hz	400V / 3Ph + PE / 50Hz					
Total input power	kW	232	264	303	344	391	419
OA (without PFC)	A	382	426	501	565	642	696
cosφ (without PFC)		0,88	0,90	0,87	0,88	0,88	0,87
OA (with PFC)	A	357	403	467	525	600	645
cosφ (with PFC)		0,94	0,95	0,94	0,95	0,94	0,94
Max. power input	kW	345	385	448	490	560	612
FLA (	A	613	673	702	790	905	982
cosφ (without PFC)		0,81	0,83	0,92	0,89	0,89	0,90
FLA (with PFC)	A	579	801	893	953	954	1172
cosφ (with PFC)		0,86	0,69	0,72	0,74	0,85	0,75
LRA (Y/D)	A	769	1035	1159	1354	1354	1582
Max. fuse (gG/aM)	A	800gG/	1000gG/ 1000aM	1000gG/ 1000aM	1250gG/ 1250aM	1250gG/ 1250aM	1250gG/ 1250aM
Ring terminals with hole/Line Helical fixing	mm/Nm	M12 / 50-75Nm	M12 / 50-75Nm	M12 / 50-75Nm	M12x2 / 50-75Nm	M12 / 50-75Nm	M12x2 / 50-75Nm
"Control power supply (only for option Fast-Start)"	V/Ph/Hz	230V / 1Ph + N + PE / 50Hz					
Pmax	kW	0,59					
Imax	A	2,3					
FLA	A	7					
Cable section min./max.	mm <sup>2</sup>	1,5 / 35					
Max. fuse (gG/aM)	A	40					
Line Helical fixing	Nm	2					
Compressor - Power input	kW	200	232	265	301	342	365
Compressor - Nominal current	A	332	376	442	498	566	612
Single compressor 1 - Max. current	A	280	310	320	360	413	447
Single compressor 1 - LRA	A	436	465	586	650	805	917
Single compressor 2 - Max. current	A	280	310	320	360	413	447
Single compressor 2 - LRA	A	436	465	586	650	805	917
Fans number	-	12	12	14	16	18	20
Fans EC Ø800 - Power input	kW	-					
Fans EC Ø800 - Nominal current	A	-					
Fans EC Ø800 - Max. current	A	-					
Fans EC Ø900 - Power input	kW	2,7					
Fans EC Ø900 - Nominal current	A	4,2					
Fans EC Ø900 - Max. current	A	4,9					
Std. head pressure pump model (option)	-	NB80- 160/147	NB80- 160/147	NB80- 160/151	NB80-1 60/151	NB80- 160/151	NB80- 160/161
Std. head pressure pump - Nominal power	kW	11	11	15	15	15	18,5
Std. head pressure pump - Motor power	kW	12,1	12,1	16,4	16,4	16,4	20,1
Std. head pressure pump - Max. current	A	19,4	19,4	26,3	26,3	26,3	31,5
Std. head pressure pump - LRA	A	136	136	184	184	184	221
High head pressure pump model (option)	-	NB80- 160/151	NB80- 160/151	NB80- 160/161	NB80- 160/161	NB80- 160/161	NB80- 160/167
High head pressure pump - Nominal power	kW	15	15	18,5	18,5	18,5	22
High head pressure pump - Motor power	kW	16	16,4	20,1	20,1	20,1	23,4
High head pressure pump - Max. current	A	26,3	26,3	31,5	31,5	31,5	38,0
Std. head pressure pump - LRA	A	184	184	221	221	221	274

Legacy Application - Outdoor temperature 35° C; fluid inlet/outlet temperature 12/7°C; water; R134A refrigerant (with R513A refrigerant indicated values are increased by 3%). The cables have to be sized in compliance with local standards and according to the type and characteristics of installation and FLA current.

OA, FLA, LRA are calculated for unit without pumps.

If the unit with EC-FAN or inverter pump is connected to an electric installation where an earthleakage circuit breaker (ELCB) is used as additional protection, the circuit breaker must be of a type marked with the followings symbols (This circuit breaker is type B.) :



**Tab. 1j - Electrical data - CDL LN 077-138**

Models CDL LN		077	089	101	116	127	138
Power supply	V/Ph/Hz	400V / 3Ph + PE / 50Hz					
Total input power	kW	229	262	299	341	384	412
OA (without PFC)	A	374	420	494	557	631	682
cosφ (without PFC)		0,88	0,90	0,87	0,88	0,88	0,87
OA (with PFC)	A	350	398	460	518	590	632
cosφ (with PFC)		0,94	0,95	0,94	0,95	0,94	0,94
Max. power input	kW	345	385	448	490	560	612
FLA	A	613	673	702	790	905	982
cosφ (without PFC)		0,81	0,83	0,92	0,89	0,89	0,90
FLA (with PFC)	A	579	801	893	953	954	1172
cosφ (with PFC)		0,86	0,69	0,72	0,74	0,85	0,75
LRA (Y/D)	A	769	1035	1159	1354	1354	1582
Max. fuse (gG/aM)	A	800gG/	1000gG/ 1000aM	1000gG/ 1000aM	1250gG/ 1250aM	1250gG/ 1250aM	1250gG/ 1250aM
Ring terminals with hole/Line Helical fixing	mm/Nm	M12 / 50-75Nm	M12 / 50-75Nm	M12 / 50-75Nm	M12x2 / 50-75Nm	M12 / 50-75Nm	M12x2 / 50-75Nm
"Control power supply (only for option Fast-Start)"	V/Ph/Hz	230V / 1Ph + N + PE / 50Hz					
Pmax	kW	0,59					
Imax	A	2,3					
FLA	A	7					
Cable section min./max.	mm <sup>2</sup>	1,5 / 35					
Max. fuse (gG/aM)	A	40					
Line Helical fixing	Nm	2					
Compressor - Power input	kW	207	240	274	312	352	376
Compressor - Nominal current	A	342	388	456	514	582	628
Single compressor 1 - Max. current	A	280	310	320	360	413	447
Single compressor 1 - LRA	A	436	465	586	650	805	917
Single compressor 2 - Max. current	A	280	310	320	360	413	447
Single compressor 2 - LRA	A	436	465	586	650	805	917
Fans number	-	12	12	14	16	18	20
Fans EC Ø800 - Power input	kW	-					
Fans EC Ø800 - Nominal current	A	-					
Fans EC Ø800 - Max. current	A	-					
Fans EC Ø900 - Power input	kW	1,8					
Fans EC Ø900 - Nominal current	A	2,7					
Fans EC Ø900 - Max. current	A	4,9					
Std. head pressure pump model (option)	-	NB80-160/147	NB80-160/147	NB80-160/151	NB80-160/151	NB80-160/151	NB80-160/161
Std. head pressure pump - Nominal power	kW	11	11	15	15	15	18,5
Std. head pressure pump - Motor power	kW	12,1	12,1	16,4	16,4	16,4	20,1
Std. head pressure pump - Max. current	A	19,4	19,4	26,3	26,3	26,3	31,5
Std. head pressure pump - LRA	A	136	136	184	184	184	221
High head pressure pump model (option)	-	NB80-160/151	NB80-160/151	NB80-160/161	NB80-160/161	NB80-160/161	NB80-160/167
High head pressure pump - Nominal power	kW	15	15	18,5	18,5	18,5	22
High head pressure pump - Motor power	kW	16	16,4	20,1	20,1	20,1	23,4
High head pressure pump - Max. current	A	26,3	26,3	31,5	31,5	31,5	38,0
Std. head pressure pump - LRA	A	184	184	221	221	221	274

Legacy Application - Outdoor temperature 35° C; fluid inlet/outlet temperature 12/7°C; water; R134A refrigerant (with R513A refrigerant indicated values are increased by 3%). The cables have to be sized in compliance with local standards and according to the type and characteristics of installation and FLA current.

OA, FLA, LRA are calculated for unit without pumps.

If the unit with EC-FAN or inverter pump is connected to an electric installation where an earthleakage circuit breaker (ELCB) is used as additional protection, the circuit breaker must be of a type marked with the followings symbols (This circuit breaker is type B.) :

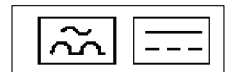

**Tab. 1k - Electrical data - CAL 077-138**

Models CAL		077	089	101	116	127	138
Power supply	V/Ph/Hz	400V / 3Ph + PE / 50Hz					
Total input power	kW	239	271	311	353	399	429
OA (without PFC)	A	389	435	512	576	653	708
cosφ (without PFC)		0,89	0,90	0,88	0,88	0,88	0,87
OA (with PFC)	A	389	435	512	576	653	708
cosφ (with PFC)		0,94	0,95	0,94	0,95	0,95	0,94
Max. power input	kW	345	385	448	490	560	612
FLA	A	613	673	702	790	905	982
cosφ (without PFC)		0,81	0,83	0,92	0,89	0,89	0,90
FLA (with PFC)	A	579	801	893	953	954	1172
cosφ (with PFC)		0,86	0,69	0,72	0,74	0,85	0,75
LRA (Y/D)	A	769	1035	1159	1354	1354	1582
Max. fuse (gG/aM)	A	800gG/	1000gG/ 1000aM	1000gG/ 1000aM	1250gG/ 1250aM	1250gG/ 1250aM	1250gG/ 1250aM
Ring terminals with hole/Line Helical fixing	mm/Nm	M12 / 50-75Nm	M12 / 50-75Nm	M12 / 50-75Nm	M12x2 / 50-75Nm	M12 / 50-75Nm	M12x2 / 50-75Nm
"Control power supply (only for option Fast-Start)"	V/Ph/Hz	230V / 1Ph + N + PE / 50Hz					
Pmax	kW	0,59					
Imax	A	2,3					
FLA	A	7					
Cable section min./max.	mm <sup>2</sup>	1,5 / 35					
Max. fuse (gG/aM)	A	40					
Line Helical fixing	Nm	2					
Compressor - Power input	kW	203,9	237	270	307	347,1	370,6
Compressor - Nominal current	A	336	382	450	506	574	620
Single compressor 1 - Max. current	A	280	310	320	360	413	447
Single compressor 1 - LRA	A	436	465	586	650	805	917
Single compressor 2 - Max. current	A	280	310	320	360	413	447
Single compressor 2 - LRA	A	436	465	586	650	805	917
Fans number	-	12	12	14	16	18	20
Fans EC Ø800 - Power input	kW	-					
Fans EC Ø800 - Nominal current	A	-					
Fans EC Ø800 - Max. current	A	-					
Fans EC Ø900 - Power input	kW	2,9					
Fans EC Ø900 - Nominal current	A	4,4					
Fans EC Ø900 - Max. current	A	4,9					
Std. head pressure pump model (option)	-	NB80- 160/147	NB80- 160/147	NB80- 160/151	NB80- 160/151	NB80- 160/151	NB80- 160/161
Std. head pressure pump - Nominal power	kW	11	11	15	15	15	18,5
Std. head pressure pump - Motor power	kW	12,1	12,1	16,4	16,4	16,4	20,1
Std. head pressure pump - Max. current	A	19,4	19,4	26,3	26,3	26,3	31,5
Std. head pressure pump - LRA	A	136	136	184	184	184	221
High head pressure pump model (option)	-	NB80- 160/151	NB80- 160/151	NB80- 160/161	NB80- 160/161	NB80- 160/161	NB80- 160/167
High head pressure pump - Nominal power	kW	15	15	18,5	18,5	18,5	22
High head pressure pump - Motor power	kW	16	16,4	20,1	20,1	20,1	23,4
High head pressure pump - Max. current	A	26,3	26,3	31,5	31,5	31,5	38,0
Std. head pressure pump - LRA	A	184	184	221	221	221	274
Adiabatic pumps model (option)	-	GXR13	GXR13	GXR13	GXR13	GXR13	GXR13
Adiabatic pumps - Number	-	4	4	4	4	4	4
Adiabatic pumps - Nominal power	kW	0,45	0,45	0,45	0,45	0,45	0,45
Adiabatic pumps - Motor power	kW	0,95	0,95	0,95	0,95	0,95	0,95
Adiabatic pumps - Max. current	A	1,6	1,60	1,60	1,60	1,60	1,60
Adiabatic pumps pump - LRA	A	-					

Legacy Application - Outdoor temperature 35° C; fluid inlet/outlet temperature 12/7° C; water; R134A refrigerant (with R513A refrigerant indicated values are increased by 3%); System adiabatic OFF. The cables have to be sized in compliance with local standards and according to the type and characteristics of installation and FLA current.

OA, FLA, LRA are calculated for unit without pumps.

If the unit with EC-FAN or inverter pump is connected to an electric installation where an earthleakage circuit breaker (ELCB) is used as additional protection, the circuit breaker must be of a type marked with the followings symbols (This circuit breaker is type B.):

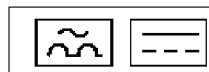

**Tab. 11 - Electrical data - CAL LN 077-138**

Models CAL LN		077	089	101	116	127	138
Power supply	V/Ph/Hz	400V / 3Ph + PE / 50Hz					
Total input power	kW	235	269	307	349	394	422
OA (without PFC)	A	382	430	505	571	642	696
cosφ (without PFC)		0,89	0,90	0,88	0,88	0,88	0,87
OA (with PFC)	A	358	407	472	531	596	646
cosφ (with PFC)		0,95	0,95	0,94	0,95	0,95	0,94
Max. power input	kW	345	385	448	490	560	612
FLA	A	613	673	702	790	905	982
cosφ (without PFC)		0,81	0,83	0,92	0,89	0,89	0,90
FLA (with PFC)	A	579	801	893	953	954	1172
cosφ (with PFC)		0,86	0,69	0,72	0,74	0,85	0,75
LRA (Y/D)	A	769	1035	1159	1354	1354	1582
Max. fuse (gG/aM)	A	800gG/	1000gG/ 1000aM	1000gG/ 1000aM	1250gG/ 1250aM	1250gG/ 1250aM	1250gG/ 1250aM
Ring terminals with hole/Line Helical fixing	mm/Nm	M12 / 50-75Nm	M12 / 50-75Nm	M12 / 50-75Nm	M12x2 / 50-75Nm	M12 / 50-75Nm	M12x2 / 50-75Nm
"Control power supply (only for option Fast-Start)"	V/Ph/Hz	230V / 1Ph + N + PE / 50Hz					
Pmax	kW	0,59					
Imax	A	2,3					
FLA	A	7					
Cable section min./max.	mm <sup>2</sup>	1,5 / 35					
Max. fuse (gG/aM)	A	40					
Line Helical fixing	Nm	2					
Compressor - Power input	kW	211,7	246	281	319	359,4	383,8
Compressor - Nominal current	A	348	396	466	526	592	640
Single compressor 1 - Max. current	A	280	310	320	360	413	447
Single compressor 1 - LRA	A	436	465	586	650	805	917
Single compressor 2 - Max. current	A	280	310	320	360	413	447
Single compressor 2 - LRA	A	436	465	586	650	805	917
Fans number	-	12	12	14	16	18	20
Fans EC Ø800 - Power input	kW	-					
Fans EC Ø800 - Nominal current	A	-					
Fans EC Ø800 - Max. current	A	-					
Fans EC Ø900 - Power input	kW	1,9					
Fans EC Ø900 - Nominal current	A	2,8					
Fans EC Ø900 - Max. current	A	4,9					
Std. head pressure pump model (option)	-	NB80- 160/147	NB80- 160/147	NB80- 160/151	NB80- 160/151	NB80- 160/151	NB80- 160/161
Std. head pressure pump - Nominal power	kW	11	11	15	15	15	18,5
Std. head pressure pump - Motor power	kW	12,1	12,1	16,4	16,4	16,4	20,1
Std. head pressure pump - Max. current	A	19,4	19,4	26,3	26,3	26,3	31,5
Std. head pressure pump - LRA	A	136	136	184	184	184	221
High head pressure pump model (option)	-	NB80- 160/151	NB80- 160/151	NB80- 160/161	NB80- 160/161	NB80- 160/161	NB80- 160/167
High head pressure pump - Nominal power	kW	15	15	18,5	18,5	18,5	22
High head pressure pump - Motor power	kW	16	16,4	20,1	20,1	20,1	23,4
High head pressure pump - Max. current	A	26,3	26,3	31,5	31,5	31,5	38,0
Std. head pressure pump - LRA	A	184	184	221	221	221	274
Adiabatic pumps model (option)	-	GXR13	GXR13	GXR13	GXR13	GXR13	GXR13
Adiabatic pumps - Number	-	4	4	4	4	4	4
Adiabatic pumps - Nominal power	kW	0,45	0,45	0,45	0,45	0,45	0,45
Adiabatic pumps - Motor power	kW	0,95	0,95	0,95	0,95	0,95	0,95
Adiabatic pumps - Max. current	A	1,6	1,60	1,60	1,60	1,60	1,60
Adiabatic pumps pump - LRA	A	-					

Legacy Application - Outdoor temperature 35° C; fluid inlet/outlet temperature 12/7° C; water; R134A refrigerant (with R513A refrigerant indicated values are increased by 3%); System adiabatic OFF. The cables have to be sized in compliance with local standards and according to the type and characteristics of installation and FLA current.

OA, FLA, LRA are calculated for unit without pumps.

If the unit with EC-FAN or inverter pump is connected to an electric installation where an earthleakage circuit breaker (ELCB) is used as additional protection, the circuit breaker must be of a type marked with the followings symbols (This circuit breaker is type B.) :

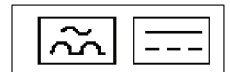

**Tab. 2 - Internal hydraulic volume**

Models		Unit volume (l)	Volume of Adiabatic System (for each bank) (l)	Volum of built-in System adiabatic (for each bank) (l)
FA4	088	1044	79	511
	102	1193	90	522
	117	1428	101	533
	130-10X- 145- 160	1644	113	545
FD4	088	1044	-	-
	102	1193	-	-
	117	1428	-	-
	130-10X- 145- 160	1644	-	-
FAL	077	923	68	500
	089	923	68	500
	101	1242	79	511
	116	1691	90	522
	127	1834	101	533
	138	1951	113	545
FDL	077	923	-	-
	089	923	-	-
	101	1242	-	-
	116	1691	-	-
	127	1834	-	-
	138	1951	-	-
CAL	077	422	68	500
	089	422	68	500
	101	568	79	511
	116	911	90	522
	127	982	101	533
	138	982	130	545
CDL	077	422	-	-
	089	422	-	-
	101	568	-	-
	116	911	-	-
	127	982	-	-
	138	982	-	-

**NOTE:**
*Internal hydraulic volume has to be increased on units with pumps option.*

**Tab. 3 - Operating range**

This diagram shows the average working limits of all the Freecooling product family.

**Average "Liebert® AFC" Working Limits**

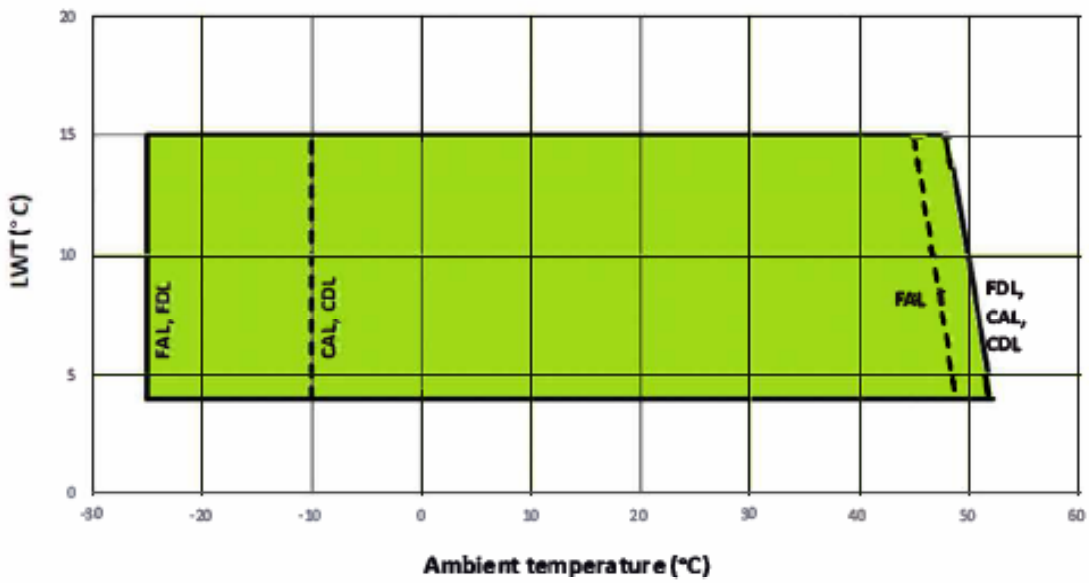
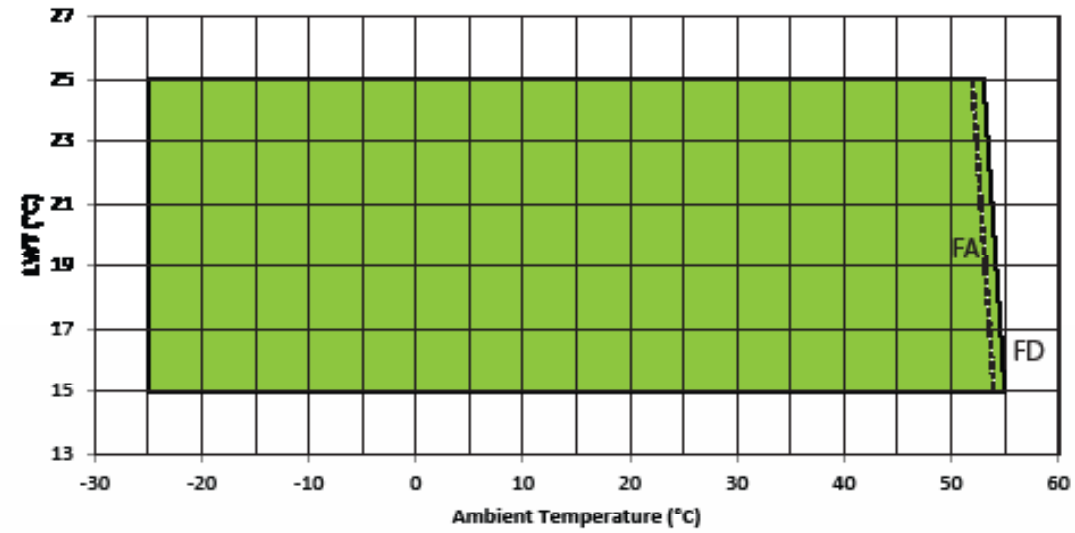

- Between - 25°C and + 45°C for all models; humidity 80% R.H.; non condensing.

**Tab. 3a - Operating range - Freecooling with Fans EC**

Models: FA4		088	102	117	130	10X	145	160
Operating range								
Max. Outdoor temperature R134a <sup>(1)</sup>	°C	53	54	53	53	54	51	49
Max. Outdoor temperature R513A <sup>(1)</sup>	°C	51	52	51	51	52	49	47
Max water flow	m <sup>3</sup> /h	240	320,9	351,8	351,8	320,9	403	403
Safety devices setting								
High pressure switch	barg	20						
High pressure safety switch	barg	22						
HP safety valve (each circuit)	#	2						
High pressure safety valve connection	inch	1.1/4" G						
Low pressure switch	barg	5						
Low pressure safety switch	barg	14						
LP safety valve (each circuit)	#	1						
Low pressure safety valve connection	inch	3/4" G						

(1) - Nominal air flow; 30% glycol mixture outlet temperature 20°C; full load

(\*) - Outdoor temperature of adiabatic versions = After PAD dry bulb air temperature

**Tab. 3b - Operating range - Freecooling with Fans EC**

Models: FD4		088	102	117	130	10X	145	160
Operating range								
Max. Outdoor temperature R134a <sup>(1)</sup>	°C	54	55	54	54	55	51	50
Max. Outdoor temperature R513A <sup>(1)</sup>	°C	52	53	52	52	53	49	48
Max water flow	m <sup>3</sup> /h	240	320,9	351,8	351,8	320,9	403	403
Safety devices setting								
High pressure switch	barg	20						
High pressure safety switch	barg	22						
HP safety valve (each circuit)	#	2						
High pressure safety valve connection	inch	1.1/4" G						
Low pressure switch	barg	5						
Low pressure safety switch	barg	14						
LP safety valve (each circuit)	#	1						
Low pressure safety valve connection	inch	3/4" G						

(1) - Nominal air flow; 30% glycol mixture outlet temperature 20°C; full load

**Tab. 3c - Operating range - Freecooling LN (Low noise) with Fans EC**

Models: FA4 + LN		088	102	117	130	10X	145	160
Operating range								
Max. Outdoor temperature R134a <sup>(1)</sup>	°C	50	50	50	49	50	46	44
Max. Outdoor temperature R513A <sup>(1)</sup>	°C	48	48	48	47	48	44	42
Max water flow	m <sup>3</sup> /h	240	320,9	351,8	351,8	320,9	403	403
Safety devices setting								
High pressure switch	barg	20						
High pressure safety switch	barg	22						
HP safety valve (each circuit)	#	2						
High pressure safety valve connection	inch	1.1/4" G						
Low pressure switch	barg	5						
Low pressure safety switch	barg	14						
LP safety valve (each circuit)	#	1						
Low pressure safety valve connection	inch	3/4" G						

(1) - Nominal air flow; 30% glycol mixture outlet temperature 20°C; full load

(\*) - Outdoor temperature of adiabatic versions = After PAD dry bulb air temperature

**Tab. 3d - Operating range - Freecooling LN (Low noise) with Fans EC**

Models: FD4 + LN		088	102	117	130	10X	145	160
Operating range								
Max. Outdoor temperature R134a <sup>(1)</sup>	°C	50	51	51	50	51	47	45
Max. Outdoor temperature R513A <sup>(1)</sup>	°C	48	49	49	48	49	45	43
Max water flow	m <sup>3</sup> /h	240	320,9	351,8	351,8	320,9	403	403
Safety devices setting								
High pressure switch	barg	20						
High pressure safety switch	barg	22						
HP safety valve (each circuit)	#	2						
High pressure safety valve connection	inch	1.1/4" G						
Low pressure switch	barg	5						
Low pressure safety switch	barg	14						
LP safety valve (each circuit)	#	1						
Low pressure safety valve connection	inch	3/4" G						

(1) - Nominal air flow; 30% glycol mixture outlet temperature 20°C; full load

**Tab. 3e - Operating range - Freecooling with Fans EC**

Models: FAL		077	089	101	116	127	138
Operating range							
Max. Outdoor temperature R134a <sup>(1)</sup>	°C	49	49	46	46	47	47
Max. Outdoor temperature R513A <sup>(1)</sup>	°C	47	47	44	44	45	45
Max water flow	m <sup>3</sup> /h	148,6	199	320,9	292,2	318,9	318,9
Safety devices setting							
High pressure switch	barg	20					
High pressure safety switch	barg	22					
HP safety valve (each circuit)	#	2					
High pressure safety valve connection	inch	1,1/4" G					
Low pressure switch	barg	5					
Low pressure safety switch	barg	14					
LP safety valve (each circuit)	#	1					
Low pressure safety valve connection	inch	3/4" G					

(1) - Nominal air flow; 30% glycol mixture outlet temperature 10°C; full load

(\*) - Outdoor temperature of adiabatic versions = After PAD dry bulb air temperature

**Tab. 3f - Operating range - Freecooling with Fans EC**

Models: FDL		077	089	101	116	127	138
Operating range							
Max. Outdoor temperature R134a <sup>(1)</sup>	°C	49	50	47	47	47	48
Max. Outdoor temperature R513A <sup>(1)</sup>	°C	47	48	45	45	45	46
Max water flow	m <sup>3</sup> /h	148,6	199	320,9	292,2	318,9	318,9
Safety devices setting							
High pressure switch	barg	20					
High pressure safety switch	barg	22					
HP safety valve (each circuit)	#	2					
High pressure safety valve connection	inch	1,1/4" G					
Low pressure switch	barg	5					
Low pressure safety switch	barg	14					
LP safety valve (each circuit)	#	1					
Low pressure safety valve connection	inch	3/4" G					

(1) - Nominal air flow; 30% glycol mixture outlet temperature 10°C; full load

**NOTES:**

The units are equipped with automatic capacity reduction system to avoid the machine lock before reaching the indicated outdoor air temperature max. limits. In the units with economizer option, such device is disabled before reaching the indicated outdoor air temperature max. limits.

**Tab. 3g - Operating range - Low Noise (LN) Freecooling with Fans EC**

Models: FAL + LN		077	089	101	116	127	138
Operating range							
Max. Outdoor temperature R134a <sup>(1)</sup>	°C	45	45	42	42	42	43
Max. Outdoor temperature R513A <sup>(1)</sup>	°C	43	43	40	40	40	41
Max water flow	m <sup>3</sup> /h	148,6	199	320,9	292,2	318,9	318,9
Safety devices setting							
High pressure switch	barg	20					
High pressure safety switch	barg	22					
HP safety valve (each circuit)	#	2					
High pressure safety valve connection	inch	1,1/4" G					
Low pressure switch	barg	5					
Low pressure safety switch	barg	14					
LP safety valve (each circuit)	#	1					
Low pressure safety valve connection	inch	3/4" G					

(1) - Nominal air flow; 30% glycol mixture outlet temperature 10°C; full load

(\*) - Outdoor temperature of adiabatic versions = After PAD dry bulb air temperature

**Tab. 3h - Operating range - Low Noise (LN) Freecooling with Fans EC**

Models: FDL + LN		077	089	101	116	127	138
Operating range							
Max. Outdoor temperature R134a <sup>(1)</sup>	°C	46	46	43	43	43	44
Max. Outdoor temperature R513A <sup>(1)</sup>	°C	44	44	41	41	41	42
Max water flow	m <sup>3</sup> /h	148,6	199	320,9	292,2	318,9	318,9
Safety devices setting							
High pressure switch	barg	20					
High pressure safety switch	barg	22					
HP safety valve (each circuit)	#	2					
High pressure safety valve connection	inch	1,1/4" G					
Low pressure switch	barg	5					
Low pressure safety switch	barg	14					
LP safety valve (each circuit)	#	1					
Low pressure safety valve connection	inch	3/4" G					

(1) - Nominal air flow; 30% glycol mixture outlet temperature 10°C; full load

**NOTES:**

The units are equipped with automatic capacity reduction system to avoid the machine lock before reaching the indicated outdoor air temperature max. limits. In the units with economizer option, such device is disabled before reaching the indicated outdoor air temperature max. limits.

**Tab. 3i - Operating range - Chiller with Fans EC**

Models: CAL		077	089	101	116	127	138
Operating range							
Max. Outdoor temperature R134a <sup>(1)</sup>	°C	51	51	50	50	50	50
Max. Outdoor temperature R513A <sup>(1)</sup>	°C	49	49	48	48	48	48
Max water flow	m <sup>3</sup> /h	148,6	199	320,9	292,2	318,9	318,9
Safety devices setting							
High pressure switch	barg	20					
High pressure safety switch	barg	22					
HP safety valve (each circuit)	#	2					
High pressure safety valve connection	inch	1,1/4" G					
Low pressure switch	barg	5					
Low pressure safety switch	barg	14					
LP safety valve (each circuit)	#	1					
Low pressure safety valve connection	inch	3/4" G					

(1) - Nominal air flow; water outlet temperature 7°C; full load

(\*) - Outdoor temperature of adiabatic versions = After PAD dry bulb air temperature

**Tab. 3I - Operating range – Chiller with Fans EC**

Models: CDL		077	089	101	116	127	138
Operating range							
Max. Outdoor temperature R134a <sup>(1)</sup>	°C	52	52	51	51	51	52
Max. Outdoor temperature R513A <sup>(1)</sup>	°C	50	50	49	49	49	50
Max water flow	m <sup>3</sup> /h	148,6	199	320,9	292,2	318,9	318,9
Safety devices setting							
High pressure switch	barg	20					
High pressure safety switch	barg	22					
HP safety valve (each circuit)	#	2					
High pressure safety valve connection	inch	1,1/4" G					
Low pressure switch	barg	5					
Low pressure safety switch	barg	14					
LP safety valve (each circuit)	#	1					
Low pressure safety valve connection	inch	3/4" G					

(1) - Nominal air flow; water outlet temperature 7°C; full load

**NOTES:**

The units are equipped with automatic capacity reduction system to avoid the machine lock before reaching the indicated outdoor air temperature max. limits. In the units with economizer option, such device is disabled before reaching the indicated outdoor air temperature max. limits.

**Tab. 3m - Operating range - Chiller with Fans EC**

Models: CAL + LN		077	089	101	116	127	138
Operating range							
Max. Outdoor temperature R134a <sup>(1)</sup>	°C	49	49	48	48	48	49
Max. Outdoor temperature R513A <sup>(1)</sup>	°C	47	47	46	46	46	47
Max water flow	m <sup>3</sup> /h	148,6	199	320,9	292,2	318,9	318,9
Safety devices setting							
High pressure switch	barg	20					
High pressure safety switch	barg	22					
HP safety valve (each circuit)	#	2					
High pressure safety valve connection	inch	1,1/4" G					
Low pressure switch	barg	5					
Low pressure safety switch	barg	14					
LP safety valve (each circuit)	#	1					
Low pressure safety valve connection	inch	3/4" G					

(1) - Nominal air flow; water outlet temperature 7°C; full load

(\*) - Outdoor temperature of adiabatic versions = After PAD dry bulb air temperature

**Tab. 3n - Operating range – Chiller with Fans EC**

Models: CDL + LN		077	089	101	116	127	138
Operating range							
Max. Outdoor temperature R134a <sup>(1)</sup>	°C	50	50	49	49	50	50
Max. Outdoor temperature R513A <sup>(1)</sup>	°C	48	48	47	47	48	48
Max water flow	m <sup>3</sup> /h	148,6	199	320,9	292,2	318,9	318,9
Safety devices setting							
High pressure switch	barg	20					
High pressure safety switch	barg	22					
HP safety valve (each circuit)	#	2					
High pressure safety valve connection	inch	1,1/4" G					
Low pressure switch	barg	5					
Low pressure safety switch	barg	14					
LP safety valve (each circuit)	#	1					
Low pressure safety valve connection	inch	3/4" G					

(1) - Nominal air flow; water outlet temperature 7°C; full load

**NOTES:**

The units are equipped with automatic capacity reduction system to avoid the machine lock before reaching the indicated outdoor air temperature max. limits. In the units with economizer option, such device is disabled before reaching the indicated outdoor air temperature max. limits.

**Tab. 4 - Refrigerant and oil charge**

FA4							
MODELS		088	102	117	130-145	160	10X
Refrigerant charge (each circuit)	[kg]	47	62	70	76	76	62
Oil charge (each circuit)	[lt]	19	30	30	30	32	30
FD4							
MODELS		088	102	117	130	160	10X
Refrigerant charge (each circuit)	[kg]	47	62	70	76	76	62
Oil charge (each circuit)	[lt]	19	30	30	30	32	30
FAL/FDL/CAL/CDL							
MODELS		077	089	101	116	127	138
Refrigerant charge (each circuit)	[kg]	41	41	46	53	60	65
Oil charge (each circuit)	[lt]	30	30	30	30	32	32

**Tab. 5 - Sound pressure level**
**SPL**

The values of Sound Pressure Level **SPL** for every octave band frequency, measured with unit on full load operation, at nominal working conditions (ambient air temperature 35°C, Evaporator water inlet/outlet temperature 12/7°C), free field conditions and 1m from unit in according to ISO 3744 average method are indicated in the following tables.

**PWL**

The values of Power Level **PWL** for every octave band frequency, with unit on full load operation, at nominal working conditions (ambient air temperature 35°C, Evaporator water inlet/outlet temperature 12/7°C), calculated in according to ISO 3744 procedure method are indicated in the following tables.

**Tab. 5a - SPL - FA4 with Fans with a diameter of 800 mm @ 1100Obr./min**

Models	Octave band frequency [Hz]								Total [dB(A)]
	63	125	250	500	1000	2000	4000	8000	
FA4	"SPL" Sound pressure levels [dB]								
088	74	77	72	74	69	66	58	51	75,0
102	75	78	73	75	70	67	59	52	75,5
117	75	78	73	75	70	67	59	52	76,0
130	75	78	73	75	70	67	59	52	76,0
10X	75	78	73	75	70	67	59	52	76,0
145	76	79	74	76	71	68	60	53	76,5
160	76	79	74	76	71	68	60	53	76,5

Sound pressure levels tolerance for each octave band: - 0/+2 dB

**Tab. 5b - PWL - FA4 with Fans with a diameter of 800 mm @ 1100Obr./min**

Models FA4	Octave band frequency [Hz]								Total [dB(A)]
	63	125	250	500	1000	2000	4000	8000	
FA4	"PWL" Sound power levels [dB]								
088	97	100	95	97	92	89	81	74	97,5
102	98	101	96	98	93	90	82	75	98,6
117	98	101	96	98	93	90	82	75	99,1
130	99	102	97	99	94	91	83	76	99,5
10X	99	102	97	99	94	91	83	76	99,5
145	100	102	97	99	94	91	83	76	100,0
160	100	102	97	99	94	91	83	76	100,0

Sound power levels tolerance for each octave band: - 0/+2 dB

**Tab. 5c - SPL - FD4 with Fans with a diameter of 800 mm @ 1100Obr./min**

Models	Octave band frequency [Hz]								Total [dB(A)]
	63	125	250	500	1000	2000	4000	8000	
<b>FD4</b>	<b>"SPL" Sound pressure levels [dB]</b>								
<b>088</b>	75	78	73	75	70	67	59	52	75,5
<b>102</b>	75	78	73	75	70	67	59	52	76,0
<b>117</b>	76	79	74	76	71	68	60	53	76,5
<b>130</b>	76	79	74	76	71	68	60	53	76,5
<b>10X</b>	76	79	74	76	71	68	60	53	76,5
<b>145</b>	77	79	74	76	71	68	60	53	77,0
<b>160</b>	77	79	74	76	71	68	60	53	77,0

Sound pressure levels tolerance for each octave band: - 0/+2 dB

**Tab. 5d - PWL - FD4 with Fans with a diameter of 800 mm @ 1100Obr./min**

Models FD4	Octave band frequency [Hz]								Total [dB(A)]
	63	125	250	500	1000	2000	4000	8000	
	<b>"PWL" Sound power levels [dB]</b>								
<b>088</b>	97	100	95	97	92	89	81	74	97,6
<b>102</b>	98	101	96	98	93	90	82	75	98,7
<b>117</b>	99	101	96	98	93	90	82	75	99,2
<b>130</b>	99	102	97	99	94	91	83	76	99,7
<b>10X</b>	99	102	97	99	94	91	83	76	99,7
<b>145</b>	100	102	97	99	94	91	83	76	100,2
<b>160</b>	100	102	97	99	94	91	83	76	100,2

Sound power levels tolerance for each octave band: - 0/+2 dB

**Tab. 5e - SPL - FA4+LN with Fans with a diameter of 800 mm @ 850Obr./min**

Models	Octave band frequency [Hz]								Total [dB(A)]
	63	125	250	500	1000	2000	4000	8000	
<b>FA4+LN</b>	<b>"SPL" Sound pressure levels [dB]</b>								
<b>088</b>	71	72	69	69	64	58	51	46	69,5
<b>102</b>	71	72	69	69	64	58	51	46	69,5
<b>117</b>	72	73	70	70	65	59	52	47	70,0
<b>130</b>	72	73	70	70	65	59	52	47	70,0
<b>10X</b>	72	73	70	70	65	59	52	47	70,0
<b>145</b>	73	73	70	70	65	59	52	47	70,5
<b>160</b>	73	73	70	70	65	59	52	47	70,5

Sound pressure level tolerance for each octave band:- 0/+2 dB

**Tab. 5f - PWL - FA4+LN with Fans with a diameter of 800 mm @ 850Obr./min**

Models FA4+LN	Octave band frequency [Hz]								Total [dB(A)]
	63	125	250	500	1000	2000	4000	8000	
	"PWL" Sound power levels [dB]								
088	94	95	92	92	87	81	74	69	92,0
102	94	95	92	92	87	81	74	69	92,5
117	95	96	93	93	88	82	75	70	93,0
130	96	96	93	93	88	82	75	70	93,5
10X	96	96	93	93	88	82	75	70	93,5
145	97	97	94	94	89	83	76	71	94,0
160	97	97	94	94	89	83	76	71	94,0

Sound power levels tolerance for each octave band: - 0/+2 dB

**Tab. 5g - SPL - FD4 + LN with Fans with a diameter of 800 mm @ 850Obr./min**

Models FD4 + LN	Octave band frequency [Hz]								Total [dB(A)]
	63	125	250	500	1000	2000	4000	8000	
	"SPL" Sound pressure levels [dB]								
088	71	73	70	70	65	59	52	47	70,0
102	72	73	70	70	65	59	52	47	70,0
117	72	73	70	70	65	59	52	47	70,5
130	72	73	70	70	65	59	52	47	70,5
10X	72	73	70	70	65	59	52	47	70,5
145	73	74	71	71	66	60	53	48	71,0
160	73	74	71	71	66	60	53	48	71,0

Sound pressure level tolerance for each octave band:- 0/+2 dB

**Tab. 5h - PWL - FD4 + LN with Fans with a diameter of 800 mm @ 850Obr./min**

Models FD4 + LN	Octave band frequency [Hz]								Total [dB(A)]
	63	125	250	500	1000	2000	4000	8000	
	"PWL" Sound power levels [dB]								
088	93	95	92	92	87	81	74	69	92,1
102	95	95	92	92	87	81	74	69	92,7
117	95	96	93	93	88	82	75	70	93,2
130	95	96	93	93	88	82	75	70	93,7
10X	95	96	93	93	88	82	75	70	93,7
145	96	97	94	94	89	83	76	71	94,2
160	96	97	94	94	89	83	76	71	94,2

Sound power levels tolerance for each octave band: - 0/+2 dB

**Tab. 5i - SPL - FA4 with Fans with a diameter of 900 mm @ 1000Obr./min**

Models	Octave band frequency [Hz]								Total [dB(A)]
	63	125	250	500	1000	2000	4000	8000	
<b>FA4</b>	<b>"SPL" Sound pressure levels [dB]</b>								
<b>088</b>	75	78	75	77	71	68	60	53	77,5
<b>102</b>	76	79	76	78	72	69	61	54	78
<b>117</b>	76	79	76	78	72	69	61	54	78,5
<b>130</b>	76	79	76	78	72	69	61	54	78,5
<b>10X</b>	76	79	76	78	72	69	61	54	78,5
<b>145</b>	77	80	77	79	73	70	62	55	79
<b>160</b>	77	80	77	79	73	70	62	55	79

Sound pressure level tolerance for each octave band -0/+2 dB

**Tab. 5j - PWL - FA4 with Fans with a diameter of 900 mm @ 1000Obr./min**

Models	Octave band frequency [Hz]								Total [dB(A)]
	63	125	250	500	1000	2000	4000	8000	
<b>FA4</b>	<b>"PWL" Sound power levels [dB]</b>								
<b>088</b>	98	101	98	100	94	91	83	76	100
<b>102</b>	99	102	99	101	95	92	84	77	101,1
<b>117</b>	99	102	99	101	95	92	84	77	101,6
<b>130</b>	100	103	100	102	96	93	85	78	102
<b>10X</b>	100	103	100	102	96	93	85	78	102
<b>145</b>	101	103	100	102	96	93	85	78	102,5
<b>160</b>	101	103	100	102	96	93	85	78	102,5

Sound power level tolerance for each octave band -0/+2 dB

**Tab. 5k - SPL - FD4 with Fans with a diameter of 900 mm @ 1000Obr./min**

Models FD4	Octave band frequency [Hz]								Total [dB(A)]
	63	125	250	500	1000	2000	4000	8000	
	<b>"SPL" Sound pressure levels [dB]</b>								
<b>088</b>	76	79	76	78	72	69	61	54	78
<b>102</b>	76	79	76	78	72	69	61	54	78,5
<b>117</b>	77	80	77	79	73	70	62	55	79
<b>130</b>	77	80	77	79	73	70	62	55	79
<b>10X</b>	77	80	77	79	73	70	62	55	79
<b>145</b>	78	80	77	79	73	70	62	55	79,5
<b>160</b>	78	80	77	79	73	70	62	55	79,5

Sound pressure level tolerance for each octave band -0/+2 dB

**Tab. 5l - PWL - FD4 with Fans with a diameter of 900 mm @ 1000Obr./min**

Models	Octave band frequency [Hz]								Total [dB(A)]
	63	125	250	500	1000	2000	4000	8000	
<b>FD4</b>	<b>"PWL" Sound power levels [dB]</b>								
<b>088</b>	98	101	98	100	94	91	83	76	100,1
<b>102</b>	99	102	99	101	95	92	84	77	101,2
<b>117</b>	100	102	99	101	95	92	84	77	101,7
<b>130</b>	100	103	100	102	96	93	85	78	102,2
<b>10X</b>	100	103	100	102	96	93	85	78	102,2
<b>145</b>	101	103	100	102	96	93	85	78	102,7
<b>160</b>	101	103	100	102	96	93	85	78	102,7

Sound power level tolerance for each octave band -0/+2 dB

**Tab. 5m - SPL - FA4 + LN with Fans with a diameter of 900 mm @ 770Obr./min**

Models	Octave band frequency [Hz]								Total [dB(A)]
	63	125	250	500	1000	2000	4000	8000	
<b>FA4</b>	<b>"SPL" Sound pressure levels [dB]</b>								
<b>088</b>	73	73	72,5	73	66	60	53	48	72,5
<b>102</b>	73	73	72,5	73	66	60	53	48	72,5
<b>117</b>	74	74	73,5	74	67	61	54	49	73
<b>130</b>	74	74	73,5	74	67	61	54	49	73
<b>10X</b>	74	74	73,5	74	67	61	54	49	73
<b>145</b>	75	74	73,5	74	67	61	54	49	73,5
<b>160</b>	75	74	73,5	74	67	61	54	49	73,5

Sound pressure level tolerance for each octave band -0/+2 dB

**Tab. 5n - PWL - FA4 + LN with Fans with a diameter of 900 mm @ 770Obr./min**

Models FA4	Octave band frequency [Hz]								Total [dB(A)]
	63	125	250	500	1000	2000	4000	8000	
	<b>"PWL" Sound power levels [dB]</b>								
<b>088</b>	96	96	95,5	96	89	83	76	71	95
<b>102</b>	96	96	95,5	96	89	83	76	71	95,5
<b>117</b>	97	97	96,5	97	90	84	77	72	96
<b>130</b>	98	97	96,5	97	90	84	77	72	96,5
<b>10X</b>	98	97	96,5	97	90	84	77	72	96,5
<b>145</b>	99	98	97,5	98	91	85	78	73	97
<b>160</b>	99	98	97,5	98	91	85	78	73	97

Sound power level tolerance for each octave band -0/+2 dB

**Tab. 5o - SPL - FD4 + LN with Fans 900mm diameter @ 770Obr./min**

Models	Octave band frequency [Hz]								Total [dB(A)]
	63	125	250	500	1000	2000	4000	8000	
<b>FD4</b>	<b>"SPL" Sound pressure levels [dB]</b>								
<b>088</b>	73	74	73,5	74	67	61	54	49	73
<b>102</b>	74	74	73,5	74	67	61	54	49	73
<b>117</b>	74	74	73,5	74	67	61	54	49	73,5
<b>130</b>	74	74	73,5	74	67	61	54	49	73,5
<b>10X</b>	74	74	73,5	74	67	61	54	49	73,5
<b>145</b>	75	75	74,5	75	68	62	55	50	74
<b>160</b>	75	75	74,5	75	68	62	55	50	74

Sound pressure level tolerance for each octave band -0/+2 dB

**Tab. 5p - PWL - FD4 + LN with Fans 900mm diameter @ 770Obr./min**

Models FD4	Octave band frequency [Hz]								Total [dB(A)]
	63	125	250	500	1000	2000	4000	8000	
	<b>"PWL" Sound power levels [dB]</b>								
<b>088</b>	95	96	95,5	96	89	83	76	71	95,1
<b>102</b>	97	96	95,5	96	89	83	76	71	95,7
<b>117</b>	97	97	96,5	97	90	84	77	72	96,2
<b>130</b>	97	97	96,5	97	90	84	77	72	96,7
<b>10X</b>	97	97	96,5	97	90	84	77	72	96,7
<b>145</b>	98	98	97,5	98	91	85	78	73	97,2
<b>160</b>	98	98	97,5	98	91	85	78	73	97,2

Sound power level tolerance for each octave band -0/+2 dB

**Tab. 5q.1 - SPL - FAL with Fans with a diameter of 800 mm @ 1100Obr./min**

Models	Octave band frequency [Hz]								Total [dB(A)]
	63	125	250	500	1000	2000	4000	8000	
<b>FAL</b>	<b>"SPL" Sound pressure levels [dB]</b>								
<b>077</b>	74	77	72	74	69	66	58	51	75
<b>089</b>	74	77	72	74	69	66	58	51	75
<b>101</b>	74	77	72	74	69	66	58	51	75
<b>116</b>	75	78	73	75	70	67	59	52	75,5
<b>127</b>	75	78	73	75	70	67	59	52	76,0
<b>138</b>	76	79	74	76	71	68	60	53	76,5

Sound pressure level tolerance for each octave band -0/+2 dB

**Tab. 5q.2 - PWL - FAL with Fans with a diameter of 800 mm @ 1100Obr./min**

Models FAL	Octave band frequency [Hz]								Total [dB(A)]
	63	125	250	500	1000	2000	4000	8000	
<b>FAL</b>	<b>"PWL" Sound power levels [dB]</b>								
<b>077</b>	96	99	94	96	91	88	80	73	96,8
<b>089</b>	96	99	94	96	91	88	80	73	96,8
<b>101</b>	97	100	95	97	92	89	81	74	97,5
<b>116</b>	98	101	96	98	93	90	82	75	98,6
<b>127</b>	98	101	96	98	93	90	82	75	99,1
<b>138</b>	100	102	97	99	94	91	83	76	100

Sound power level tolerance for each octave band -0/+2 dB

**Tab. 5r.1 - SPL - FAL with Fans with a diameter of 900 mm @ 1000Obr./min**

Models	Octave band frequency [Hz]								Total [dB(A)]
	63	125	250	500	1000	2000	4000	8000	
<b>FAL</b>	<b>"SPL" Sound pressure levels [dB]</b>								
<b>077</b>	75	78	75	77	71	68	60	53	77,5
<b>089</b>	75	78	75	77	71	68	60	53	77,5
<b>101</b>	75	78	75	77	71	68	60	53	77,5
<b>116</b>	76	79	76	78	72	69	61	54	78
<b>127</b>	76	79	76	78	72	69	61	54	78,5
<b>138</b>	77	80	77	79	73	70	62	55	79

Sound pressure level tolerance for each octave band -0/+2 dB

**Tab. 5r.2 - - PWL - FAL with Fans with a diameter of 900 mm @ 1000Obr./min**

Models FAL	Octave band frequency [Hz]								Total [dB(A)]
	63	125	250	500	1000	2000	4000	8000	
<b>FAL</b>	<b>"PWL" Sound power levels [dB]</b>								
<b>077</b>	97	99	97	98	93	89	91	75	99,3
<b>089</b>	97	99	97	98	93	89	91	75	99,3
<b>101</b>	98	101	98	100	94	91	83	76	100
<b>116</b>	99	102	99	101	95	92	84	77	101,1
<b>127</b>	99	102	99	101	95	92	84	77	101,6
<b>138</b>	101	103	100	102	96	93	85	78	102,5

Sound power level tolerance for each octave band -0/+2 dB

**Tab. 5s.1 - SPL – FAL+LN with Fans with a diameter of 800 mm @ 850Obr./min**

Models	Octave band frequency [Hz]								Total [dB(A)]
	63	125	250	500	1000	2000	4000	8000	
<b>FAL+LN</b>	<b>“SPL” Sound pressure levels [dB]</b>								
<b>077</b>	70	71	69	68	63	57	50	46	69
<b>089</b>	70	71	69	68	63	57	50	46	69
<b>101</b>	71	72	69	69	64	58	51	46	69,5
<b>116</b>	71	72	69	69	64	58	51	46	69,5
<b>127</b>	72	73	70	70	65	59	52	47	70
<b>138</b>	73	73	70	70	65	59	52	47	70,5

Sound pressure level tolerance for each octave band -0/+2 dB

**Tab. 5s.2 - PWL - FAL+LN with Fans with a diameter of 800 mm @ 850Obr./min**

Models FAL+LN	Octave band frequency [Hz]								Total [dB(A)]
	63	125	250	500	1000	2000	4000	8000	
	<b>“PWL” Sound power levels [dB]</b>								
<b>077</b>	93	94	91	91	85	80	73	68	90,8
<b>089</b>	93	94	91	91	85	80	73	68	90,8
<b>101</b>	94	95	92	92	87	81	74	69	92
<b>116</b>	94	95	92	92	87	81	74	69	92,5
<b>127</b>	95	96	93	93	88	82	75	70	93
<b>138</b>	97	97	94	94	89	83	76	71	94

Sound power level tolerance for each octave band -0/+2 dB

**Tab. 5t.1 - SPL - FAL+LN with Fans with a diameter of 900 mm @ 770Obr./min**

Models	Octave band frequency [Hz]								Total [dB(A)]
	63	125	250	500	1000	2000	4000	8000	
<b>FAL+LN</b>	<b>“SPL” Sound pressure levels [dB]</b>								
<b>077</b>	72	73	72	73	65	59	52	47	72
<b>089</b>	72	73	72	73	65	59	52	47	72
<b>101</b>	73	73	72,5	73	66	60	53	48	72,5
<b>116</b>	73	73	72,5	73	66	60	53	48	72,5
<b>127</b>	74	74	73,5	74	67	61	54	49	73
<b>138</b>	75	74	73,5	74	67	61	54	49	73,5

Sound pressure level tolerance for each octave band -0/+2 dB

**Tab. 5t.2 - - PWL - FAL+LN with Fans with a diameter of 900 mm @ 770Obr./min**

Models FAL+LN	Octave band frequency [Hz]								Total [dB(A)]
	63	125	250	500	1000	2000	4000	8000	
	<b>“PWL” Sound power levels [dB]</b>								
<b>077</b>	95	95	94	94	87	82	75	70	93,8
<b>089</b>	95	95	94	94	87	82	75	70	93,8
<b>101</b>	96	96	95,5	96	89	83	76	71	95
<b>116</b>	96	96	95,5	96	89	83	76	71	95,5
<b>127</b>	97	97	96,5	97	90	84	77	72	96
<b>138</b>	99	98	97,5	98	91	85	78	73	97

Sound power level tolerance for each octave band -0/+2 dB

**Tab. 5u.1 - SPL – FDL with Fans with a diameter of 800 mm @ 1100Obr./min**

Models	Octave band frequency [Hz]								Total [dB(A)]
	63	125	250	500	1000	2000	4000	8000	
<b>FDL</b>	<b>“SPL” Sound pressure levels [dB]</b>								
<b>077</b>	75	78	73	75	70	67	59	52	75,5
<b>089</b>	75	78	73	75	70	67	59	52	75,5
<b>101</b>	75	78	73	75	70	67	59	52	75,5
<b>116</b>	75	78	73	75	70	67	59	52	76
<b>127</b>	76	79	74	76	71	68	60	53	76,5
<b>138</b>	77	79	74	76	71	68	60	53	77

Sound pressure level tolerance for each octave band -0/+2 dB

**Tab. 5u.2 - PWL - FDL with Fans with a diameter of 800 mm @ 1100Obr./min**

Models FDL	Octave band frequency [Hz]								Total [dB(A)]
	63	125	250	500	1000	2000	4000	8000	
<b>FDL</b>	<b>“PWL” Sound power levels [dB]</b>								
<b>077</b>	96	99	94	96	91	88	80	73	96,9
<b>089</b>	96	99	94	96	91	88	80	73	96,9
<b>101</b>	97	100	95	97	92	89	81	74	97,6
<b>116</b>	98	101	96	98	93	90	82	75	98,7
<b>127</b>	99	101	96	98	93	90	82	75	99,2
<b>138</b>	100	102	97	99	94	91	83	76	100,2

Sound power level tolerance for each octave band -0/+2 dB

**Tab. 5v.1 - SPL - FDL with Fans with a diameter of 900 mm @ 1000Obr./min**

Models	Octave band frequency [Hz]								Total [dB(A)]
	63	125	250	500	1000	2000	4000	8000	
<b>FDL</b>	<b>“SPL” Sound pressure levels [dB]</b>								
<b>077</b>	76	79	76	78	72	69	61	54	78
<b>089</b>	76	79	76	78	72	69	61	54	78
<b>101</b>	76	79	76	78	72	69	61	54	78
<b>116</b>	76	79	76	78	72	69	61	54	78,5
<b>127</b>	77	80	77	79	73	70	62	55	79
<b>138</b>	78	80	77	79	73	70	62	55	79,5

Sound pressure level tolerance for each octave band -0/+2 dB

**Tab. 5v.2 - - PWL - FDL with Fans with a diameter of 900 mm @ 1000Obr./min**

Models FDL	Octave band frequency [Hz]								Total [dB(A)]
	63	125	250	500	1000	2000	4000	8000	
<b>FDL</b>	<b>“PWL” Sound power levels [dB]</b>								
<b>077</b>	97	99	97	98	93	89	91	75	99,4
<b>089</b>	97	99	97	98	93	89	91	75	99,4
<b>101</b>	98	101	98	100	94	91	83	76	100,1
<b>116</b>	99	102	99	101	95	92	84	77	101,2
<b>127</b>	100	102	99	101	95	92	84	77	101,7
<b>138</b>	101	103	100	102	96	93	85	78	102,7

Sound power level tolerance for each octave band -0/+2 dB

**Tab. 5w.1 - SPL – FDL+LN with Fans with a diameter of 800 mm @ 850obr./min**

Models	Octave band frequency [Hz]								Total [dB(A)]
	63	125	250	500	1000	2000	4000	8000	
<b>FDL+LN</b>	<b>“SPL” Sound pressure levels [dB]</b>								
<b>077</b>	71	72	69	69	64	58	51	46	69,5
<b>089</b>	71	72	69	69	64	58	51	46	69,5
<b>101</b>	71	73	70	70	65	59	52	47	70
<b>116</b>	72	73	70	70	65	59	52	47	70
<b>127</b>	72	73	70	70	65	59	52	47	70,5
<b>138</b>	73	74	71	71	66	60	53	48	71

Sound pressure level tolerance for each octave band -0/+2 dB

**Tab. 5w.2 - PWL – FDL+LN with Fans with a diameter of 800 mm @ 850obr./min**

Models FDL+LN	Octave band frequency [Hz]								Total [dB(A)]
	63	125	250	500	1000	2000	4000	8000	
	<b>“PWL” Sound power levels [dB]</b>								
<b>077</b>	93	94	91	91	85	80	73	68	90,9
<b>089</b>	93	94	91	91	85	80	73	68	90,9
<b>101</b>	93	95	92	92	87	81	74	69	92,1
<b>116</b>	95	95	92	92	87	81	74	69	92,7
<b>127</b>	95	96	93	93	88	82	75	70	93,2
<b>138</b>	96	97	94	94	89	83	76	71	94,2

Sound power level tolerance for each octave band -0/+2 dB

**Tab. 5x.1 - SPL– FDL+LN with Fans with a diameter of 900 mm @ 770Obr./min**

Models	Octave band frequency [Hz]								Total [dB(A)]
	63	125	250	500	1000	2000	4000	8000	
<b>FDL+LN</b>	<b>“SPL” Sound pressure levels [dB]</b>								
<b>077</b>	73	73	72,5	73	66	60	53	48	72,5
<b>089</b>	73	73	72,5	73	66	60	53	48	72,5
<b>101</b>	73	74	73,5	74	67	61	54	49	73
<b>116</b>	74	74	73,5	74	67	61	54	49	73
<b>127</b>	74	74	73,5	74	67	61	54	49	73,5
<b>138</b>	75	75	74,5	75	68	62	55	50	74

Sound pressure level tolerance for each octave band -0/+2 dB

**Tab. 5x.2 - - PWL – FDL+LN with Fans with a diameter of 900 mm @ 770Obr./min**

Models FDL+LN	Octave band frequency [Hz]								Total [dB(A)]
	63	125	250	500	1000	2000	4000	8000	
	<b>“PWL” Sound power levels [dB]</b>								
<b>077</b>	95	95	94	94	87	82	75	70	93,9
<b>089</b>	95	95	94	94	87	82	75	70	93,9
<b>101</b>	95	96	95,5	96	89	83	76	71	95,1
<b>116</b>	97	96	95,5	96	89	83	76	71	95,7
<b>127</b>	97	97	96,5	97	90	84	77	72	96,2
<b>138</b>	98	98	97,5	98	91	85	78	73	97,2

Sound power level tolerance for each octave band -0/+2 dB

**Tab. 5y.1 - CAL with Fans with a diameter of 900 mm @ 1000Obr./min**

Models	Octave band frequency [Hz]								Total [dB(A)]
	63	125	250	500	1000	2000	4000	8000	
<b>CAL</b>	<b>"SPL" Sound pressure levels [dB]</b>								
<b>077</b>	78	80	77	79	73	70	62	55	79,5
<b>089</b>	78	80	77	79	73	70	62	55	79,5
<b>101</b>	78	80	77	79	73	70	62	55	79,5
<b>116</b>	78	81	78	80	74	70	62	55	80,0
<b>127</b>	79	82	79	80	75	71	63	56	80,5
<b>138</b>	79	82	79	80	75	71	63	56	80,5

Sound pressure level tolerance for each octave band -0/+2 dB

**Tab. 5y.2 - CAL with Fans with a diameter of 900 mm @ 1000Obr./min**

Models CAL	Octave band frequency [Hz]								Total [dB(A)]
	63	125	250	500	1000	2000	4000	8000	
<b>CAL</b>	<b>"PWL" Sound power levels [dB]</b>								
<b>077</b>	100	102	99	101	96	93	84	77	101,7
<b>089</b>	100	102	99	101	96	93	84	77	101,7
<b>101</b>	101	103	100	102	96	93	85	78	102,1
<b>116</b>	102	104	101	103	97	94	86	79	103,0
<b>127</b>	102	105	101	104	97	94	86	79	103,5
<b>138</b>	103	105	102	104	97	95	87	80	104,0

Sound power level tolerance for each octave band -0/+2 dB

**Tab. 5z.1 - SPL- CAL+LN with Fans with a diameter of 900 mm @ 770Obr./min**

Models	Octave band frequency [Hz]								Total [dB(A)]
	63	125	250	500	1000	2000	4000	8000	
<b>CAL+LN</b>	<b>"SPL" Sound pressure levels [dB]</b>								
<b>077</b>	73	76	72	74	68	65	58	51	74,5
<b>089</b>	73	76	72	74	68	65	58	51	74,5
<b>101</b>	73	76	72	74	68	65	58	51	74,5
<b>116</b>	74	77	72	74	69	66	58	51	75,0
<b>127</b>	75	78	73	75	70	67	59	52	75,5
<b>138</b>	75	78	73	75	70	67	59	52	76,0

Sound pressure level tolerance for each octave band -0/+2 dB

**Tab. 5z.2 - - PWL - CAL+LN with Fans with a diameter of 900 mm @ 770Obr./min**

Models CAL+LN	Octave band frequency [Hz]								Total [dB(A)]
	63	125	250	500	1000	2000	4000	8000	
<b>CAL+LN</b>	<b>"PWL" Sound power levels [dB]</b>								
<b>077</b>	95	96	97	97	89	83	76	72	96,2
<b>089</b>	98	97	97	98	90	85	78	73	96,7
<b>101</b>	99	98	97,5	98	91	85	78	73	97,1
<b>116</b>	99	98	98	98	92	85	78	73	98
<b>127</b>	99	99	99	99	93	86	79	74	98,6
<b>138</b>	99	100	100	100	93	86	80	74	99,5

Sound power level tolerance for each octave band -0/+2 dB

**Tab. 5aa.1 - CDL with Fans with a diameter of 900 mm @ 1000Obr./min**

Models	Octave band frequency [Hz]								Total [dB(A)]
	63	125	250	500	1000	2000	4000	8000	
<b>CDL</b>	<b>"SPL" Sound pressure levels [dB]</b>								
<b>077</b>	78	81	78	80	74	70	62	55	80
<b>089</b>	78	81	78	80	74	70	62	55	80
<b>101</b>	78	81	78	80	74	70	62	55	80
<b>116</b>	79	82	79	80	75	71	63	56	80,5
<b>127</b>	79	82	79	81	76	71	63	56	81
<b>138</b>	79	82	79	81	76	71	63	56	81

Sound pressure level tolerance for each octave band -0/+2 dB

**Tab. 5aa.2 - CDL with Fans with a diameter of 900 mm @ 1000Obr./min**

Models CDL	Octave band frequency [Hz]								Total [dB(A)]
	63	125	250	500	1000	2000	4000	8000	
	<b>"PWL" Sound power levels [dB]</b>								
<b>077</b>	100	102	99	101	96	93	84	77	101,6
<b>089</b>	100	102	99	101	96	93	84	77	101,6
<b>101</b>	101	103	100	102	96	93	85	78	102
<b>116</b>	102	104	101	103	97	94	86	79	102,9
<b>127</b>	103	105	102	104	97	95	87	80	103,7
<b>138</b>	103	106	102	104	98	95	87	80	104,2

Sound power level tolerance for each octave band -0/+2 dB

**Tab. 5ab.1 - SPL- CDL+LN with Fans with a diameter of 900 mm @ 770Obr./min**

Models	Octave band frequency [Hz]								Total [dB(A)]
	63	125	250	500	1000	2000	4000	8000	
<b>CDL+LN</b>	<b>"SPL" Sound pressure levels [dB]</b>								
<b>077</b>	74	77	72	74	69	66	58	51	75
<b>089</b>	74	77	72	74	69	66	58	51	75
<b>101</b>	74	77	72	74	69	66	58	51	75
<b>116</b>	75	78	73	75	70	67	59	52	75,5
<b>127</b>	75	78	73	75	70	67	59	52	76
<b>138</b>	76	79	74	76	71	68	60	53	76,5

Sound pressure level tolerance for each octave band -0/+2 dB

**Tab. 5ab.2 - - PWL - CDL+LN with Fans with a diameter of 900 mm @ 770Obr./min**

Models CDL+LN	Octave band frequency [Hz]								Total [dB(A)]
	63	125	250	500	1000	2000	4000	8000	
	<b>"PWL" Sound power levels [dB]</b>								
<b>077</b>	98	97	97	98	90	85	78	73	96,6
<b>089</b>	98	97	97	98	90	85	78	73	96,6
<b>101</b>	99	98	97,5	98	91	85	78	73	97
<b>116</b>	99	98	98	98	92	85	78	73	97,9
<b>127</b>	99	99	99	99	93	86	79	74	98,7
<b>138</b>	99	100	100	100	93	86	80	74	99,7

Sound power level tolerance for each octave band -0/+2 dB

## Tab. 6 - Pump group characteristics

**Tab. 6a - 2 Pole, standard head pressure (data referred to each pump)**

Models			088	102	117	130	10X	145	160
FA4 / FD4	30% glycol-water mixture flow	m <sup>3</sup> /h	150,4	170,4	196,3	222,8	170,4	247,8	261
	Available pressure head	kPa	107	107	67	14	46	69	75
Pumps number		No	2						
Pump rotor model		-	65-160/ 173	80-160/161			100-160/ 169	100-160/ 176	
Nominal rotor power		kW	15	18,5			30	37	
Noise level (*)		dB(A)	60	60			71	71	
Each pump weight		kg	154			205	299	299	

(\*) - According to ISO 3744

**Tab. 6b - 2 Pole, high head pressure (data referred to each pump)**

Models			088	102	117	130	10X	145	160
FA4 / FD4	30% glycol-water mixture flow	m <sup>3</sup> /h	150	170,4	196,3	222,8	170,4	247,8	261
	Available pressure head	kPa	134	147	108	52	86	162	207
Pumps number		No	2						
Pump rotor model		-	65-160/ 177	80-160/167			100-200/ 181	100-200/ 192	
Nominal rotor power		kW	18,5	22			37	45	
Noise level (*)		dB(A)	60	66			71	71	
Each pump weight		kg	158	221			315	439	

(\*) - According to ISO 3744

**Tab. 6c - 2 Pole, standard head pressure (data referred to each pump)**

Models			077	089	101	116	127	138
FAL / FDL	30% glycol-water mixture flow	m <sup>3</sup> /h	140	155	185	215	235	260
	Available pressure head	kPa	92	101	76	20	82	70
Pumps number		No	2					
Pump rotor model		-	65-160/ 173	80-160/161			100-160/ 169	100-160/ 176
Nominal rotor power		kW	15	18,5			30	37
Noise level (*)		dB(A)	60	60			71	71
Each pump weight		kg	154	205			299	299

(\*) - According to ISO 3744

**Tab. 6d - 2 Pole, high head pressure (data referred to each pump)**

Models			077	089	101	116	127	138
FAL / FDL	30% glycol-water mixture flow	m <sup>3</sup> /h	140	155	185	215	235	260
	Available pressure head	kPa	119	141	117	59	176	202
Pumps number		No	2					
Pump rotor model		-	65-160/ 177	80-160/167			100- 200/181	100- 200/192
Nominal rotor power		kW	18,5	22			37	45
Noise level (*)		dB(A)	60	66			71	71
Each pump weight		kg	158	221			315	439

(\*) - According to ISO 3744

**Tab. 6e - 2 Pole, standard head pressure (data referred to each pump)**

Models			077	089	101	116	127	138
CAL / CDL	30% glycol-water mixture flow	m3/h	123	139	164	190	206	226
	Available pressure head	kPa	120	127	149	123	117	139
Pumps number		No	2					
Pump rotor model		-	80-160/147	80-160/151			80-160/161	100-200/192
Nominal rotor power		kW	11	15			18,5	45
Noise level (*)		dB(A)	60	60			60	71
Each pump weight		kg	178	192			205	439

(\*) - According to ISO 3744

**Tab. 6f - 2 Pole, high head pressure (data referred to each pump)**

Models			077	089	101	116	127	138
CAL / CDL	30% glycol-water mixture flow	m3/h	123	139	164	190	206	226
	Available pressure head	kPa	189	195	201	176	170	176
Pumps number		No	2					
Pump rotor model		-	80-160/151	80-160/161			80-160/167	100-200/192
Nominal rotor power		kW	15	18,5			22	45
Noise level (*)		dB(A)	60	60			66	71
Each pump weight		kg	178	205			221	439

(\*) - According to ISO 3744

**Fig. 1 - Service areas (top view)**

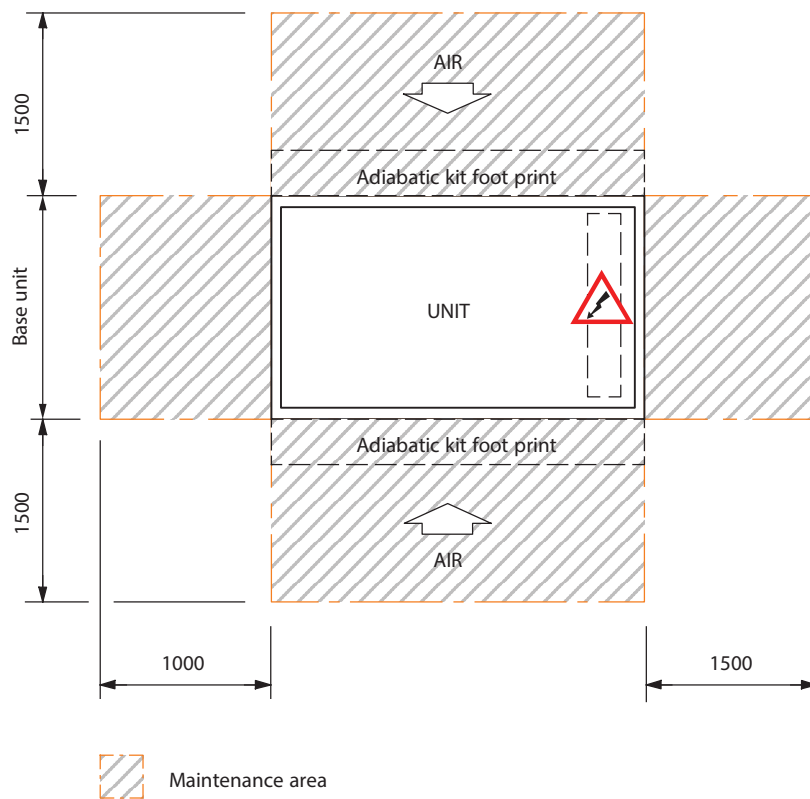

**NOTES:**

Minimum distance between 2 units from Wężownica skraplacza side = 3 m.  
Do not obstruct the air exiting the Fans for a minimum distance of 2.5 m.

**Fig. 2 - Pipe connection system**

OD	Ø	3"	4"	5"	6"	8"
	DN	80	100	125	150	200
	Ø mm	88.9	114.3	139.7	168.3	219.1
A	mm	15.88	15.88	15.88	15.88	15.88
Tolerance	mm	±0,77	±0,77	±0,77	±0,77	±0,77
B	mm	7.95	9.53	9.53	9.53	11.13
Tolerance	mm	±0,77	±0,77	±0,77	±0,77	±0,77
C	mm	1.98	2.11	2.13	2.16	2.34
D	Ø mm	84,94	110,08	135,50	163,96	214,4
	mm	- 0,51	- 0,51	- 0,56	- 0,56	- 0,64
	mm	+0,00	+0,00	+0,00	+0,00	+0,00

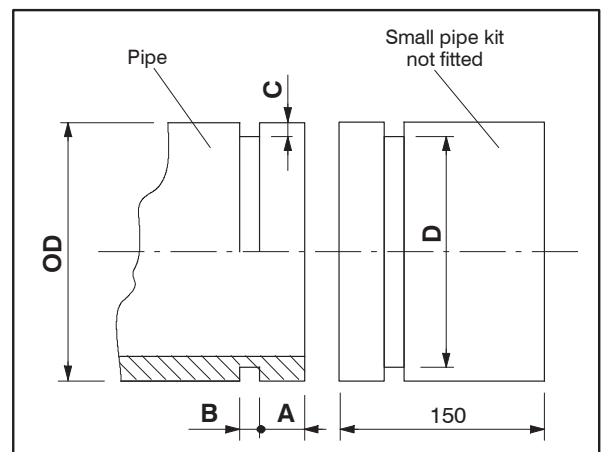

For welded hydraulic connection use the "line sections" supplied, otherwise directly connect grooved lines with the joints of the unit, taking care to suitably grease the joint gaskets.

**Fig. 3 - Lifting instructions with 4 bars (12- 20 Fans) FA version**

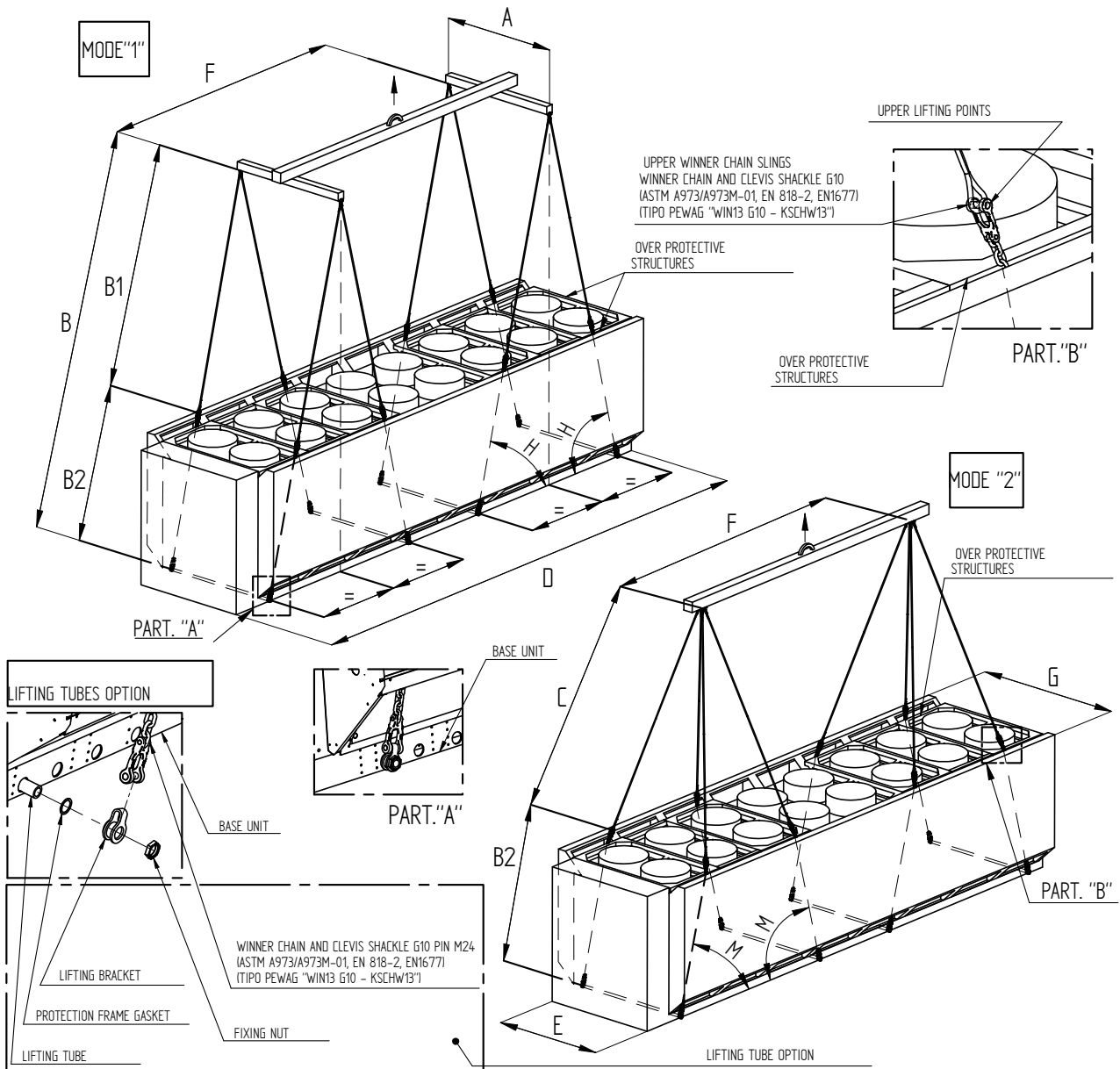

**N.B.:** Place the lifting tubes in the holes in the base indicated by the words "lift here". Lock the ends of the tubes in position with the fixing nut as shown above, using 60 mm span. The capacity of the lifting gear must be adequate to lift the load in question. Check the weight of the units, the capacity of the lifting gear and ropes and the condition and suitability of the aforementioned equipment. Lift the unit with a speed suitable for the load to be moved, so as not to damage the **Liebert® AFC**. Respect absolutely points upper (part. "B"), the lengths of lifting slings ("B1") and corners tilt ("h-m") indicated in the following table. It is absolutely forbidden to use the frames upper protection chains / cables for rigging lifting. Check that the slings are perfectly positioned before starting to lifting operations. Use of protective rubber or polyurethane in structures contact point with lifting slings. Complete the liftings rigging and positioning of the machines remove the lifting accessory (ropes, slings, chains, brackets and tubes). After lifting and positioning the unit, remove lifting accessories (ropes, slings, chains, hooks, brackets and tubes). Lifting tools as: hooks, lifting gear, ropes, chords, belts, rigid struts, protection plank are not provided with the unit.

AFC Helical Models			Fans no.	A	B1	B2	B = B1+B2	C	D	E	F	G	H	M
FA4	FAL	CAL		(mm)	(mm)	(mm)	(mm)	(mm)	(mm)	(mm)	(mm)	(mm)	(mm)	(°)
	<b>077 - 089</b>	<b>077 - 089</b>	12	2370	> 5100 < 7900	2890	> 7990 < 10790	"> 5400 < 7900"	8281	2260 /2308	5090	2998	> 78° < 85°	> 83° < 85°
<b>088</b>	<b>101</b>	<b>101</b>	14	2370	> 4700 < 5400	2890	> 7590 < 8290	"> 4850 < 5400"	9551	2260 /2308	4455	2998	> 75° < 77°	> 75° < 77°
<b>102</b>	<b>116</b>	<b>116</b>	16	2370	> 4700 < 5400	2890	> 7590 < 8290	"> 4850 < 5400"	10821	2260 /2308	5725	2998	> 75° < 77°	> 75° < 77°
<b>117</b>	<b>127</b>	<b>127</b>	18	2370	> 4700 < 5400	2890	> 7590 < 8290	"> 4850 < 5400"	12091	2260 /2308	6995	2998	> 75° < 77°	> 75° < 77°
<b>130 - 10X 145 - 160</b>	<b>138</b>	<b>138</b>	20	2370	> 4700 < 5400	2890	> 7590 < 8290	"> 4850 < 5400"	13361	2260 /2308	8265	2998	> 75° < 77°	> 75° < 77°

**Fig. 4 - Lifting instructions with 4 bars (12- 20 Fans)**

FD and FA versions with System adiabatic assembled after unit is positioned

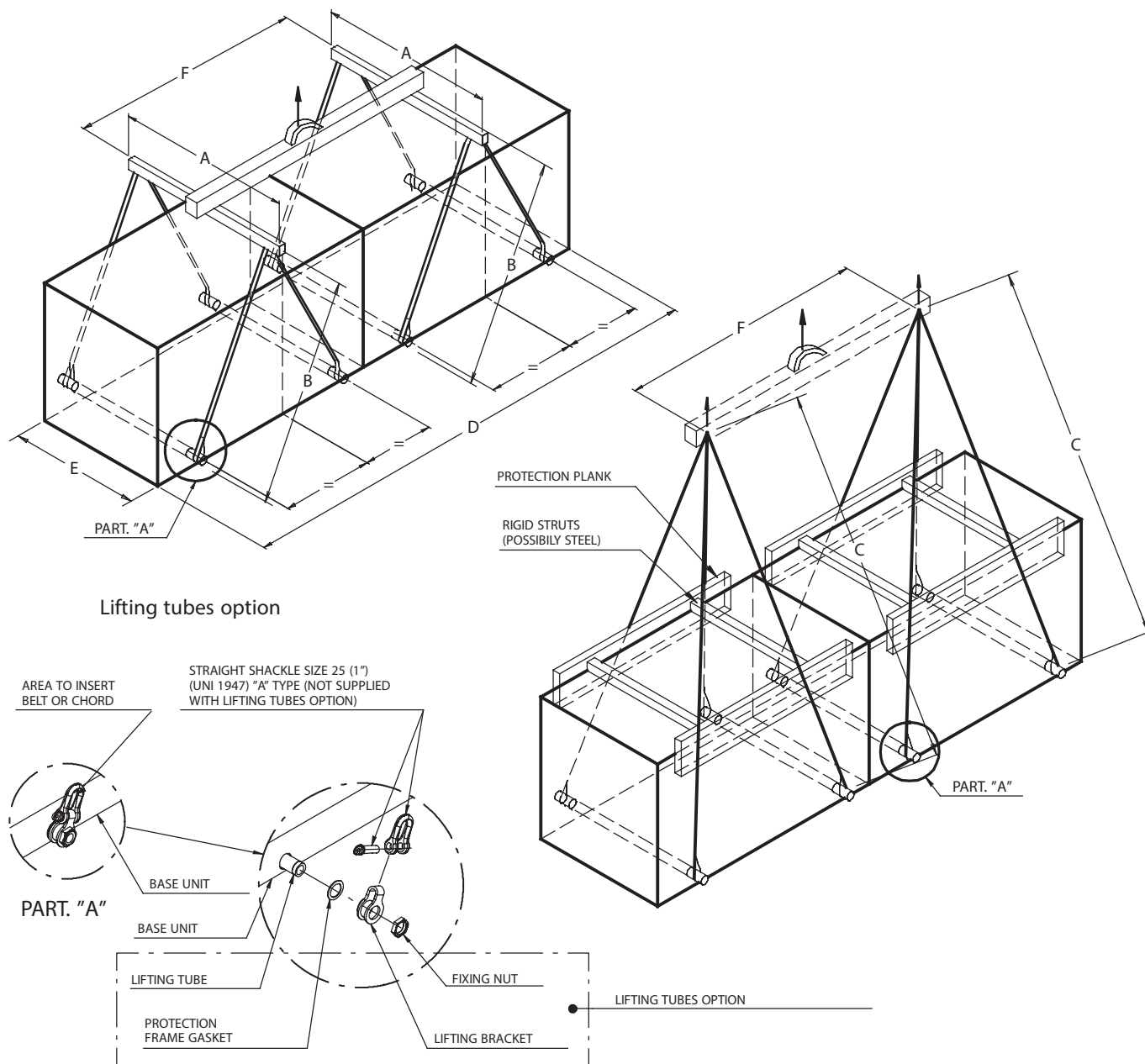

**N.B.:** Place the lifting tubes in the holes in the base indicated by the word 'LIFT HERE'. Lock the ends of the tubes in position with the ring nut as shown above, using 60 mm span.

The capacity of the lifting gear must be adequate to lift the load in question. Check the weight of the units, the capacity of the lifting gear and ropes and the condition and suitability of the aforementioned equipment.

Lift the unit with a speed suitable for the load to be moved, so as not to damage the Liebert® AFC structure.

After lifting and positioning the unit, remove lifting accessories (ropes, slings, chains, hooks, brackets and tubes).

Lifting tools as: hooks, lifting gear, ropes, chords, belts, rigid struts, protection plank are not provided with the unit.

**Tab. 4a - Lifting**

AFC Models FD4/ FA4	Fans no.	"A" (mm)	"B" (mm)	"C" (mm)	"D" (mm)	"E" (mm)	"F" (mm)
	12	2750	≈ 4500	≈ 10000	8281	2260 / 2308	5090
<b>088</b>	14	2750	≈ 4500	≈ 10000	9551	2260 / 2308	4455
<b>102</b>	16	2750	≈ 4500	≈ 10000	10821	2260 / 2308	5725
<b>117</b>	18	2750	≈ 4500	≈ 10000	12091	2260 / 2308	6995
<b>130 - 10X 145 - 160</b>	20	2750	≈ 4500	≈ 10000	13361	2260 / 2308	8265

**Fig. 5 - Lifting barycentric axis with 4 bars FA models**

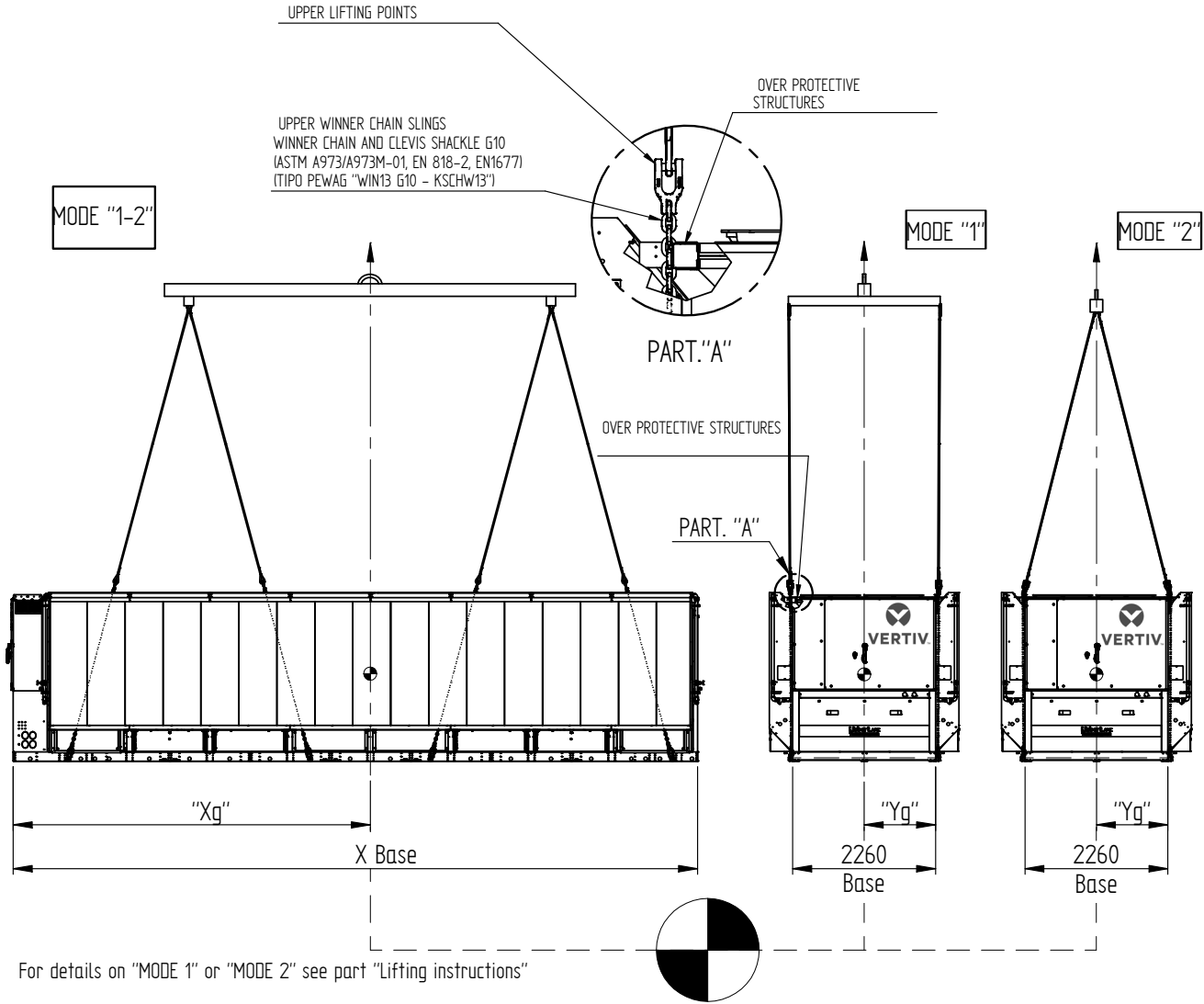

**NOTE:** The lifting point has to be on the vertical barycentric axis, which is individualized by symbols indicated on the base.

**Tab. 5a - Shipping weight and unit barycentric position**  
(4-rods lifting)

Models	X base		Unit without pumps		Unit with pumps		
	(mm)	Xg (mm)	Yg (mm)	Shipping weight (kg)	Xg (mm)	Yg (mm)	Shipping weight (kg)
FA4088	9551	4914	1114	10474	4790	1119	11065
FA4102	10821	5539	1108	12216	5388	1114	12937
FA4117	12091	6114	1106	13229	5943	1111	13955
FA4130	13361	6918	1107	14306	6708	1113	15072
FA4145	13361	6939	1112	14634	6655	1120	15715
FA4160	13361	6939	1114	14860	6590	1124	16193
FA410X	13361	6898	1105	13692	6680	1111	14458
FAL077	8281	4287	1108	10231	4202	1117	10697
FAL089	8281	4287	1108	10256	4196	1117	10760
FAL101	9551	4937	1114	11554	4807	1118	12228
FAL116	10821	5572	1117	12857	5416	1122	13573
FAL127	12091	6290	1117	14056	6046	1125	15107
FAL138	13361	6969	1114	14942	6621	1124	16280
CAL077	8281	4259	1143	9259	4170	1147	9720
CAL089	8281	4259	1142	9284	4170	1146	9745
CAL101	9551	4907	1153	10385	4969	1130	10905
CAL116	10821	5542	1157	11556	5647	1126	12195
CAL127	12091	6250	1157	12654	6378	1127	13313
CAL138	13361	6940	1156	13350	7095	1126	14041

**NOTE:** Total weight with the System adiabatic assembled in the factory.

**NOTE:** The weight of the low noise versions increases by 350 kg, but the position of the center of gravity does not change.

**Tab. 5b- Shipping weight and unit barycentric position with integrated tank**  
(4-rods lifting)

Models	X base	Unit without pumps			Unit with pumps		
	(mm)	Xg (mm)	Yg (mm)	Shipping weight (kg)	Xg (mm)	Yg (mm)	Shipping weight (kg)
FA4088	9551	4920	1115	11174	4803	1120	11765
FA4102	10821	5545	1109	12916	5401	1114	13637
FA4117	12091	6123	1107	13929	5959	1112	14655
FA4130	13361	6918	1108	15006	6717	1114	15772
FA4145	13361	6938	1113	15334	6666	1121	16415
FA4160	13361	6938	1115	15560	6604	1124	16893
FA410X	13361	6899	1107	14392	6691	1112	15158
FAL077	8281	4290	1109	10581	4208	1117	11047
FAL089	8281	4290	1108	10606	4201	1118	11110
FAL101	9551	4941	1115	12254	4818	1118	12928
FAL116	10821	5576	1117	13557	5428	1123	14273
FAL127	12091	6289	1117	14756	6057	1125	15807
FAL138	13361	6967	1115	15642	6633	1124	16980
CAL077	8281	4263	1142	9609	4177	1146	10070
CAL089	8281	4264	1142	9634	4177	1146	10095
CAL101	9551	4914	1151	11085	4972	1130	11605
CAL116	10821	5548	1155	12256	5647	1126	12895
CAL127	12091	6252	1155	13354	6373	1127	14013
CAL138	13361	6938	1154	14050	7087	1127	14741

**NOTE:** Total weight with the System adiabatic assembled in the factory.

**NOTE:** The weight of the low noise versions increases by 350 kg, but the position of the center of gravity does not change.

Fig. 6 - Lifting barycentric axis with 4 bars FD models

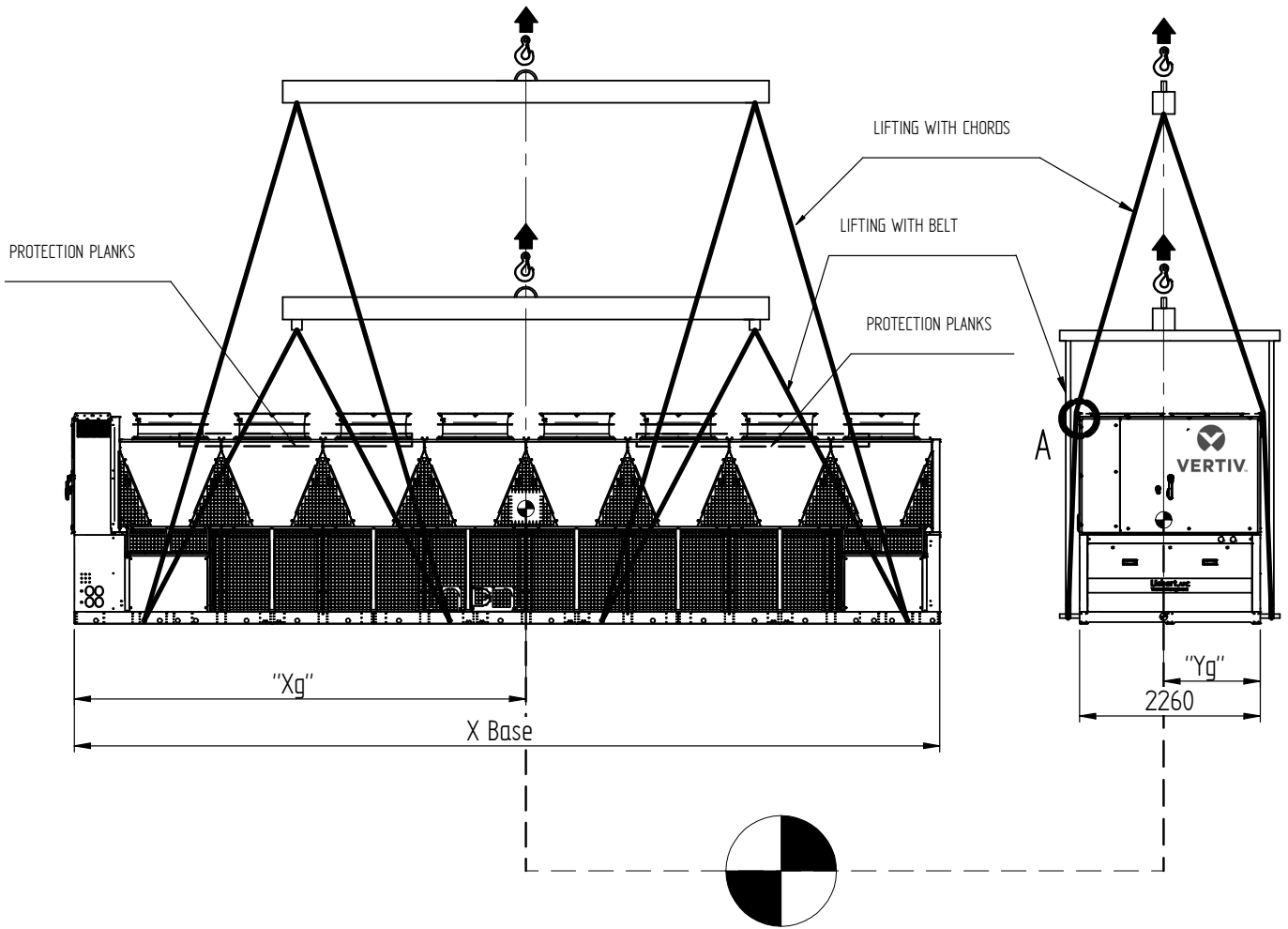

**N.B.** The lifting point has to be on the vertical barycentric axis, which is individualized by symbols indicated on the base.

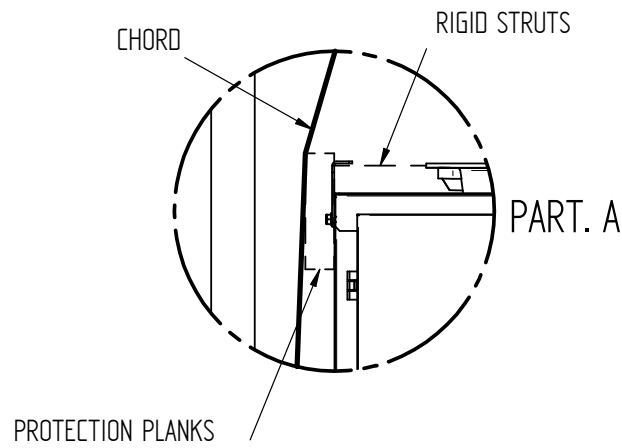

Models	X base	Unit without pumps			Unit with pumps		
	(mm)	Xg (mm)	Yg (mm)	Shipping weight (kg)	Xg (mm)	Yg (mm)	Shipping weight (kg)
<b>FD4088</b>	9551	4905	1113	9474	4770	1118	10065
<b>FD4102</b>	10821	5530	1106	11103	5365	1112	11824
<b>FD4117</b>	12091	6099	1103	11985	5911	1109	12711
<b>FD4130</b>	13361	6920	1105	13020	6690	1111	13786
<b>FD4145</b>	13361	6942	1111	13348	6633	1120	14429
<b>FD4160</b>	13361	6942	1112	13574	6563	1123	14907
<b>FD410X</b>	13361	6898	1103	12406	6658	1109	13172
<b>FDL077</b>	8281	4281	1106	9398	4189	1116	9864
<b>FDL089</b>	8281	4281	1106	9423	4182	1116	9927
<b>FDL101</b>	9551	4932	1113	10554	4791	1117	11228
<b>FDL116</b>	10821	5566	1115	11744	5397	1121	12460
<b>FDL127</b>	12091	6292	1116	12812	6027	1125	13863
<b>FDL138</b>	13361	6976	1113	13656	6597	1124	14994
<b>CDL077</b>	8281	4249	1144	8419	4152	1148	8880
<b>CDL089</b>	8281	4249	1143	8444	4152	1148	8905
<b>CDL101</b>	9551	4898	1155	9374	4967	1130	9894
<b>CDL116</b>	10821	5532	1160	10394	5649	1125	11033
<b>CDL127</b>	12091	6249	1160	11386	6390	1127	12045
<b>CDL138</b>	13361	6944	1158	12029	7115	1126	12720

**NOTE:** The weight of the low noise versions increases by 350 kg, but the position of the center of gravity does not change.

**Fig. 7 - Rubber anti-vibration support (cod. 269122)**

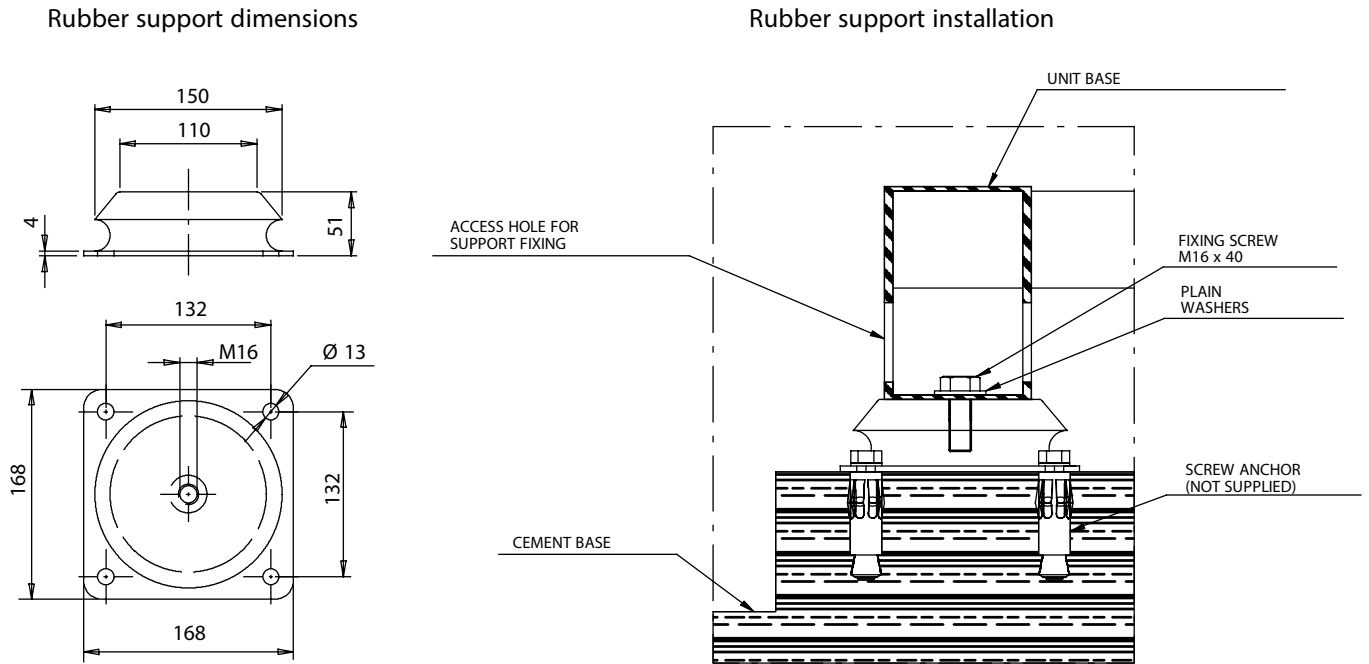

**Tab. 7a - Rubber supports**

AFC Units Model							
FD4/FA4	FDL/FAL	CDL/CAL	Fans no.	Configuration	Support kit code	Single support code	Kit support pieces
	077 - 089	077 - 089	12	with or without pumps with or without adiabatic with or without pumps + adiabatic	454868	269122	10
088	101	101	14		454869		12
102	116	116	16				
117	127	127	18				
130 - 10X 145 - 160	138	138	20		454870		14

Each kit is complete with stainless steel fixing Helicals and plain washers for unit assembly.

**Fig. 8 - Support positions and loads**

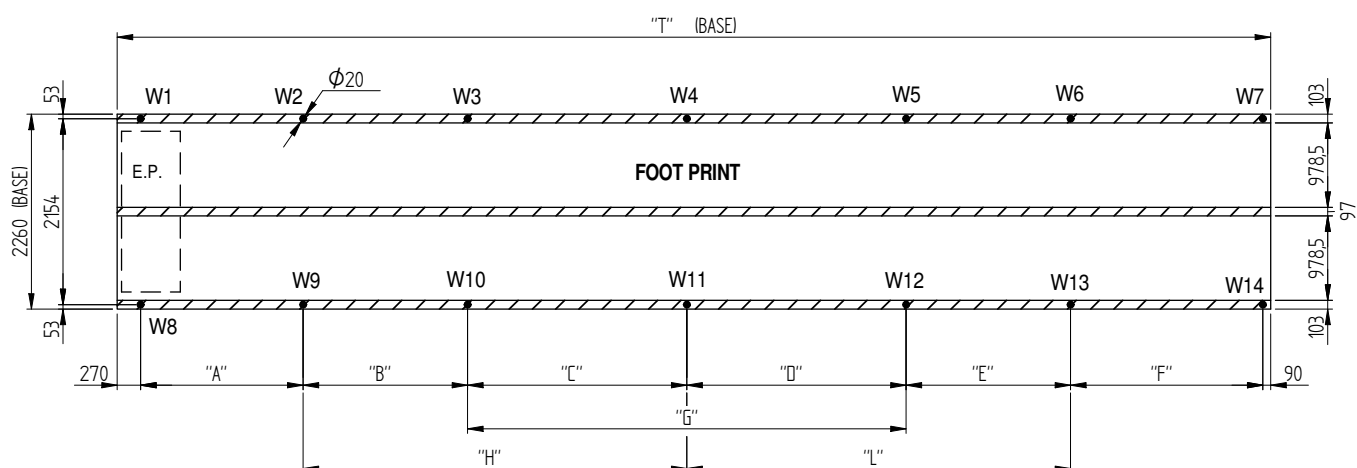

**Tab. 8a - Dimensions**

FA4/FD4	-	088	102	117	130- 10X- 145- 160
FAL/FDL	077-089	101	116	127	138
CAL/CDL	077-089	101	116	127	138
n. Fans	12	14	16	18	20
n antivib.	10	12		14	
"A" (mm)	1883,5	1883,5	1883,5	1883,5	1883,5
"B" (mm)	-----	1905	1905	1905	1905
"C" (mm)	-----	-----	-----	1905	2540
"D" (mm)	-----	-----	-----	2540	1905
"E" (mm)	-----	1905	2540	1905	2540
"F" (mm)	1592,5	1592,5	2227,5	1592,5	2227.5
"G" (mm)	-----	1905	1905	-----	-----
"H" (mm)	1905	-----	-----	-----	-----
"L" (mm)	2540	-----	-----	-----	-----
"T" (mm)	8281	9551	10821	12091	13361

Tab 8b - Weight working distribution - Unit without pumps

Model	Weight distribution (kg)														TOT. (kg)
	W1	W2	W3	W4	W5	W6	W7	W8	W9	W10	W11	W12	W13	W14	
FA4088	954	954	954	-	958	958	958	984	984	984	-	988	988	988	11652
FA4102	988	988	988	-	1203	1203	1203	1050	1050	1050	-	1279	1279	1279	13560
FA4117	1034	1034	1034	1034	1010	1010	1010	1098	1098	1098	1098	1072	1072	1072	14774
FA4130	992	992	992	992	1265	1265	1265	1054	1054	1054	1054	1344	1344	1344	16011
FA4145	1031	1031	1031	1031	1346	1346	1346	1072	1072	1072	1072	1401	1401	1401	16653
FA4160	1046	1046	1046	1046	1364	1364	1364	1086	1086	1086	1086	1416	1416	1416	16868
FA410X	952	952	952	952	1191	1191	1191	1021	1021	1021	1021	1278	1278	1278	15299
FAL077	1065	1065	-	1065	-	1127	1127	1126	1126	-	1126	-	1191	1191	11209
FAL089	1067	1067	-	1067	-	1129	1129	1129	1129	-	1129	-	1194	1194	11234
FAL101	1039	1039	1039	-	1060	1060	1060	1086	1086	1086	-	1107	1107	1107	12876
FAL116	1066	1066	1066	-	1344	1344	1344	1094	1094	1094	-	1380	1380	1380	14652
FAL127	1072	1072	1072	1072	1205	1205	1205	1100	1100	1100	1100	1238	1238	1238	16017
FAL138	1046	1046	1046	1046	1396	1396	1396	1083	1083	1083	1083	1445	1445	1445	17039
CAL077	979	979	-	979	-	1008	1008	946	946	-	946	-	974	974	9739
CAL089	981	981	-	981	-	1010	1010	949	949	-	949	-	977	977	9764
CAL101	950	950	950	-	945	945	945	894	894	894	-	889	889	889	11034
CAL116	976	976	976	-	1206	1206	1206	898	898	898	-	1110	1110	1110	12570
CAL127	980	980	980	980	1080	1080	1080	904	904	904	904	996	996	996	13764
CAL138	944	944	944	944	1248	1248	1248	873	873	873	873	1155	1155	1155	14477

Model	Weight distribution (kg)														TOT. (kg)
	W1	W2	W3	W4	W5	W6	W7	W8	W9	W10	W11	W12	W13	W14	
FD4088	858	858	858	-	860	860	860	888	888	888	888	-	890	890	10488
FD4102	892	892	892	-	1083	1083	1083	954	954	954	-	1158	1158	1158	12261
FD4117	932	932	932	932	904	904	904	996	996	996	996	965	965	965	13319
FD4130	892	892	892	892	1145	1145	1145	954	954	954	954	1225	1225	1225	14494
FD4145	931	931	931	931	1226	1226	1226	973	973	973	973	1281	1281	1281	15137
FD4160	946	946	946	946	1244	1244	1244	986	986	986	986	1296	1296	1296	15348
FD410X	852	852	852	852	1071	1071	1071	921	921	921	921	1158	1158	1158	13779
FDL077	971	971	-	971	-	1025	1025	1032	1032	-	1032	-	1089	1089	10237
FDL089	973	973	-	973	-	1027	1027	1035	1035	-	1035	-	1092	1092	10262
FDL101	943	943	943	-	961	961	961	990	990	990	-	1009	1009	1009	11709
FDL116	970	970	970	-	1224	1224	1224	998	998	998	-	1259	1259	1259	13353
FDL127	970	970	970	970	1099	1099	1099	998	998	998	998	1132	1132	1132	14565
FDL138	946	946	946	946	1276	1276	1276	983	983	983	983	1326	1326	1326	15522
CDL077	884	884	-	884	-	905	905	851	851	-	851	-	871	871	8757
CDL089	886	886	-	886	-	907	907	854	854	-	854	-	874	874	8782
CDL101	853	853	853	-	846	846	846	797	797	797	-	790	790	790	9858
CDL116	876	876	876	-	1081	1081	1081	798	798	798	-	985	985	985	11220
CDL127	876	876	876	876	972	972	972	800	800	800	800	888	888	888	12284
CDL138	842	842	842	842	1126	1126	1126	772	772	772	772	1032	1032	1032	12930

NOTE: Total weight with the System adiabatic assembled in the factory.

NOTE: The weight of the low noise versions increases by 350 kg, subdivided in equal amounts on the unit supports.

**Tab 8.c - Weight working distribution - Unit without pumps with integrated tank**

Model	Weight distribution (kg)														TOT. (kg)
	W1	W2	W3	W4	W5	W6	W7	W8	W9	W10	W11	W12	W13	W14	
FA4088	1115	1115	1115	-	1124	1124	1124	1144	1144	1144	-	1154	1154	1154	13611
FA4102	1132	1132	1132	-	1385	1385	1385	1194	1194	1194	-	1461	1461	1461	15516
FA4117	1171	1171	1171	1171	1153	1153	1153	1234	1234	1234	1234	1216	1216	1216	16727
FA4130	1120	1120	1120	1120	1420	1420	1420	1183	1183	1183	1183	1499	1499	1499	17969
FA4145	1159	1159	1159	1159	1502	1502	1502	1201	1201	1201	1201	1555	1555	1555	18611
FA4160	1174	1174	1174	1174	1519	1519	1519	1214	1214	1214	1214	1571	1571	1571	18822
FA410X	1080	1080	1080	1080	1346	1346	1346	1149	1149	1149	1149	1433	1433	1433	17253
FAL077	1159	1159	-	1159	-	1230	1230	1220	1220	-	1220	-	1295	1295	12187
FAL089	1161	1161	-	1161	-	1233	1233	1223	1223	-	1223	-	1298	1298	12214
FAL101	1199	1199	1199	-	1225	1225	1225	1246	1246	1246	-	1273	1273	1273	14829
FAL116	1210	1210	1210	-	1527	1527	1527	1238	1238	1238	-	1562	1562	1562	16611
FAL127	1208	1208	1208	1208	1349	1349	1349	1237	1237	1237	1237	1381	1381	1381	17970
FAL138	1174	1174	1174	1174	1552	1552	1552	1211	1211	1211	1211	1600	1600	1600	18996
CAL077	1072	1072	-	1072	-	1111	1111	1040	1040	-	1040	-	1077	1077	10712
CAL089	1074	1074	-	1074	-	1113	1113	1043	1043	-	1043	-	1080	1080	10737
CAL101	1110	1110	1110	-	1111	1111	1111	1054	1054	1054	-	1055	1055	1055	12990
CAL116	1120	1120	1120	-	1388	1388	1388	1042	1042	1042	-	1292	1292	1292	14526
CAL127	1117	1117	1117	1117	1224	1224	1224	1040	1040	1040	1040	1140	1140	1140	15720
CAL138	1073	1073	1073	1073	1403	1403	1403	1002	1002	1002	1002	1310	1310	1310	16439

**NOTE:** Total weight with the System adiabatic assembled in the factory.

**NOTE:** The weight of the low noise versions increases by 350 kg, subdivided in equal amounts on the unit supports.

Tab 8d - Weight working distribution - Unit with pumps

Model	Weight distribution (kg)														TOT. (kg)
	W1	W2	W3	W4	W5	W6	W7	W8	W9	W10	W11	W12	W13	W14	
FA4088	1060	1060	1060	-	970	970	970	1090	1090	1090	-	997	997	997	12351
FA4102	1117	1117	1117	-	1227	1227	1227	1171	1171	1171	-	1286	1286	1286	14403
FA4117	1150	1150	1150	1150	1011	1011	1011	1205	1205	1205	1205	1060	1060	1060	15633
FA4130	1120	1120	1120	1120	1263	1263	1263	1174	1174	1174	1174	1325	1325	1325	16940
FA4145	1204	1204	1204	1204	1345	1345	1345	1231	1231	1231	1231	1375	1375	1375	17900
FA4160	1257	1257	1257	1257	1360	1360	1360	1278	1278	1278	1278	1383	1383	1383	18369
FA410X	1080	1080	1080	1080	1189	1189	1189	1142	1142	1142	1142	1257	1257	1257	16226
FAL077	1152	1152	-	1152	-	1137	1137	1199	1199	-	1199	-	1183	1183	11693
FAL089	1161	1161	-	1161	-	1141	1141	1207	1207	-	1207	-	1186	1186	11758
FAL101	1161	1161	1161	-	1070	1070	1070	1213	1213	1213	-	1118	1118	1118	13686
FAL116	1204	1204	1204	-	1364	1364	1364	1223	1223	1223	-	1385	1385	1385	15528
FAL127	1240	1240	1240	1240	1210	1210	1210	1255	1255	1255	1255	1225	1225	1225	17285
FAL138	1258	1258	1258	1258	1394	1394	1394	1278	1278	1278	1278	1417	1417	1417	18577
CAL077	1061	1061	-	1061	-	1014	1014	1020	1020	-	1020	-	974	974	10219
CAL089	1063	1063	-	1063	-	1016	1016	1023	1023	-	1023	-	977	977	10244
CAL101	955	955	955	-	991	991	991	940	940	940	-	976	976	976	11586
CAL116	962	962	962	-	1278	1278	1278	943	943	943	-	1253	1253	1253	13308
CAL127	971	971	971	971	1152	1152	1152	951	951	951	951	1128	1128	1128	14528
CAL138	928	928	928	928	1333	1333	1333	911	911	911	911	1308	1308	1308	15279

Model	Weight distribution (kg)														TOT. (kg)
	W1	W2	W3	W4	W5	W6	W7	W8	W9	W10	W11	W12	W13	W14	
FD4088	965	965	965	-	872	872	872	994	994	994	-	898	898	898	11187
FD4102	1021	1021	1021	-	1106	1106	1106	1075	1075	1075	-	1165	1165	1165	13101
FD4117	1070	1070	1070	924	924	924	924	1127	1127	1127	973	973	973	973	14179
FD4130	1020	1020	1020	1020	1144	1144	1144	1075	1075	1075	1075	1205	1205	1205	15427
FD4145	1104	1104	1104	1104	1226	1226	1226	1131	1131	1131	1131	1256	1256	1256	16386
FD4160	1157	1157	1157	1157	1240	1240	1240	1178	1178	1178	1178	1263	1263	1263	16849
FD410X	980	980	980	980	1070	1070	1070	1042	1042	1042	1042	1137	1137	1137	14709
FDL077	1058	1058	-	1058	-	1035	1035	1105	1105	-	1105	-	1081	1081	10721
FDL089	1067	1067	-	1067	-	1038	1038	1113	1113	-	1113	-	1083	1083	10782
FDL101	1065	1065	1065	-	972	972	972	1117	1117	1117	-	1019	1019	1019	12519
FDL116	1108	1108	1108	-	1243	1243	1243	1127	1127	1127	-	1264	1264	1264	14226
FDL127	1138	1138	1138	1138	1104	1104	1104	1153	1153	1153	1153	1118	1118	1118	15830
FDL138	1158	1158	1158	1158	1275	1275	1275	1178	1178	1178	1178	1297	1297	1297	17060
CDL077	967	967	-	967	-	910	910	925	925	-	925	-	871	871	9238
CDL089	969	969	-	969	-	912	912	928	928	-	928	-	874	874	9263
CDL101	858	858	858	-	892	892	892	843	843	843	-	876	876	876	10407
CDL116	862	862	862	-	1153	1153	1153	843	843	843	-	1128	1128	1128	11958
CDL127	867	867	867	867	1044	1044	1044	847	847	847	847	1020	1020	1020	13048
CDL138	825	825	825	825	1210	1210	1210	808	808	808	808	1186	1186	1186	13720

NOTE: Total weight with the System adiabatic assembled in the factory.

NOTE: The weight of the low noise versions increases by 350 kg, subdivided in equal amounts on the unit supports.

Tab 8e - Weight working distribution - Unit with pumps with integrated tank

Model	Weight distribution (kg)														TOT. (kg)
	W1	W2	W3	W4	W5	W6	W7	W8	W9	W10	W11	W12	W13	W14	
FA4088	1221	1221	1221	-	1136	1136	1136	1250	1250	1250	-	1163	1163	1163	14310
FA4102	1262	1262	1262	-	1409	1409	1409	1315	1315	1315	-	1468	1468	1468	16362
FA4117	1287	1287	1287	1287	1154	1154	1154	1342	1342	1342	1342	1204	1204	1204	17590
FA4130	1249	1249	1249	1249	1418	1418	1418	1303	1303	1303	1303	1480	1480	1480	18902
FA4145	1332	1332	1332	1332	1500	1500	1500	1359	1359	1359	1359	1531	1531	1531	19857
FA4160	1385	1385	1385	1385	1515	1515	1515	1406	1406	1406	1406	1538	1538	1538	20323
FA410X	1208	1208	1208	1208	1344	1344	1344	1270	1270	1270	1270	1412	1412	1412	18180
FAL077	1246	1246	-	1246	-	1240	1240	1293	1293	-	1293	-	1287	1287	12671
FAL089	1255	1255	-	1255	-	1244	1244	1301	1301	-	1301	-	1289	1289	12734
FAL101	1321	1321	1321	-	1236	1236	1236	1373	1373	1373	-	1284	1284	1284	15642
FAL116	1348	1348	1348	-	1546	1546	1546	1367	1367	1367	-	1567	1567	1567	17484
FAL127	1377	1377	1377	1377	1354	1354	1354	1392	1392	1392	1392	1369	1369	1369	19245
FAL138	1387	1387	1387	1387	1549	1549	1549	1407	1407	1407	1407	1572	1572	1572	20539
CAL077	1155	1155	-	1155	-	1117	1117	1114	1114	-	1114	-	1077	1077	11195
CAL089	1157	1157	-	1157	-	1119	1119	1117	1117	-	1117	-	1080	1080	11220
CAL101	1115	1115	1115	-	1157	1157	1157	1100	1100	1100	-	1141	1141	1141	13539
CAL116	1106	1106	1106	-	1460	1460	1460	1087	1087	1087	-	1436	1436	1436	15267
CAL127	1108	1108	1108	1108	1296	1296	1296	1087	1087	1087	1087	1272	1272	1272	16484
CAL138	1056	1056	1056	1056	1488	1488	1488	1039	1039	1039	1039	1463	1463	1463	17233

NOTE: Total weight with the System adiabatic assembled in the factory.

NOTE: The weight of the low noise versions increases by 350 kg, subdivided in equal amounts on the unit supports.

## Fig. 9 - Dimensional data

### FIG 9.1 - OVERALL Dimensions AFC FD/CD Helical 12 Fans

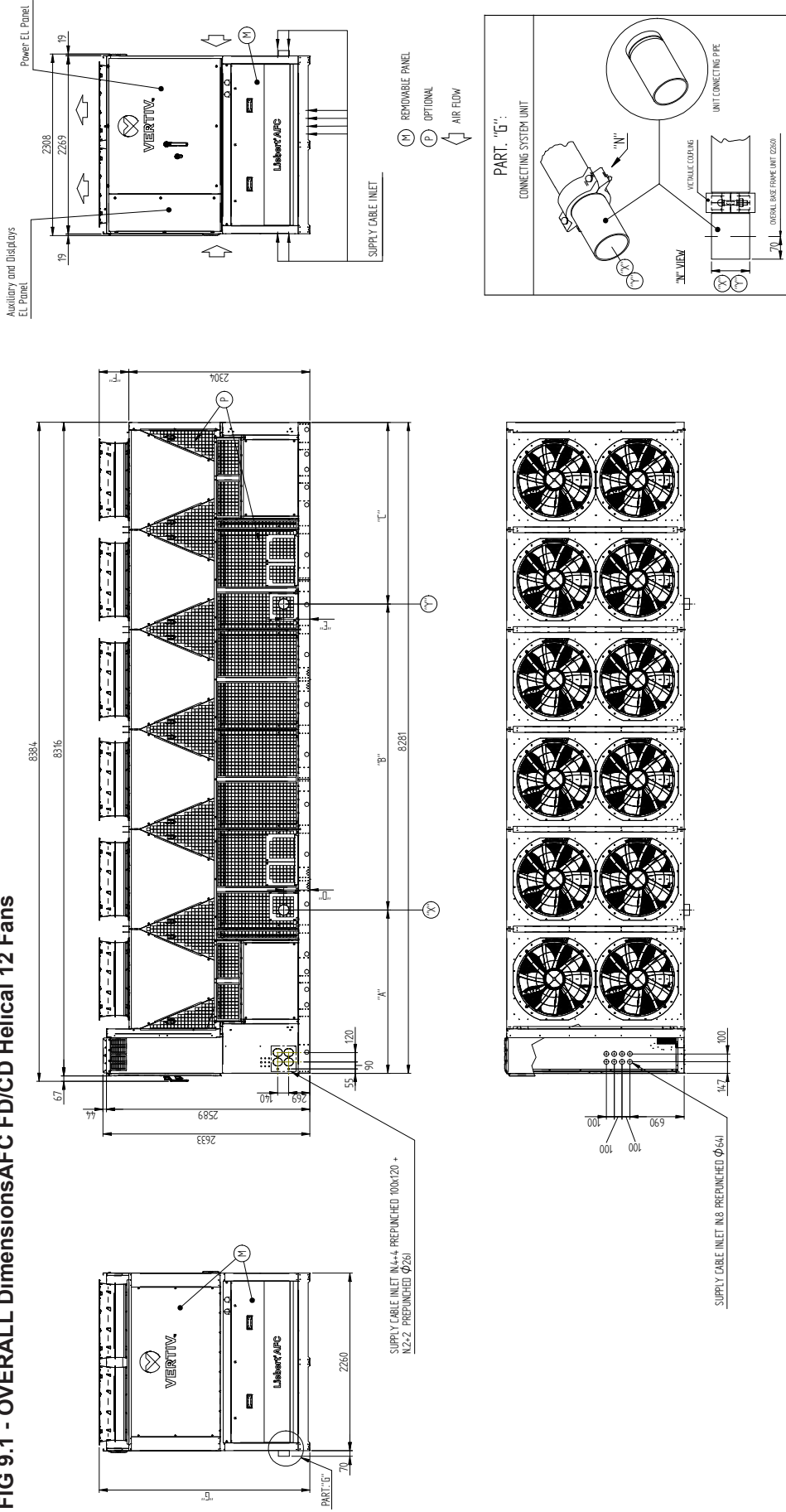

\* For shipment this dimension is reduced of 164mm.

Model	Version	N. Fans	Fans EC diam.800												Fans EC diam.900		AC Fans diam.900		Chilled Water connections	
			A (mm)	B (mm)	C (mm)	D (mm)	E (mm)	F (mm)	G (mm)	F (mm)	G (mm)	F (mm)	G (mm)	"X" (mm)	"Y" (mm)	Inlet	Outlet	Inlet	Outlet	
FDL 077	Without Pumps	12	2080	3893	2308	332	332	326	326	2630	2630	378	2682	-	-	-	-	Grooved DN125-5"	Grooved DN125-5"	
	With Pumps std low press.		2080	3893	2308	332	332	326	326	2630	2630	378	2682	-	-	-	-	Grooved DN125-5"	Grooved DN125-5"	
	With Pumps high press.		2080	3893	2308	332	332	326	326	2630	2630	378	2682	-	-	-	-	Grooved DN125-5"	Grooved DN125-5"	
CDL 077	Without Pumps	12	2080	3893	2308	332	332	326	326	2630	2630	453*	2757*	249	2553	249	2553	Grooved DN125-5"	Grooved DN125-5"	
	With Pumps std low press.		2080	3893	2308	332	332	326	326	2630	2630	453*	2757*	249	2553	249	2553	Grooved DN125-5"	Grooved DN125-5"	
	With Pumps high press.		2080	3893	2308	332	332	326	326	2630	2630	453*	2757*	249	2553	249	2553	Grooved DN125-5"	Grooved DN125-5"	
CDL 089	With Inverter Pump		2080	3893	2308	332	332	326	326	2630	2630	453*	2757*	249	2553	249	2553	Grooved DN125-5"	Grooved DN125-5"	



**FIG 9.3 - OVERALL Dimensions AFC Helical FA/CA 12 Fans WITH ADIABATIC**

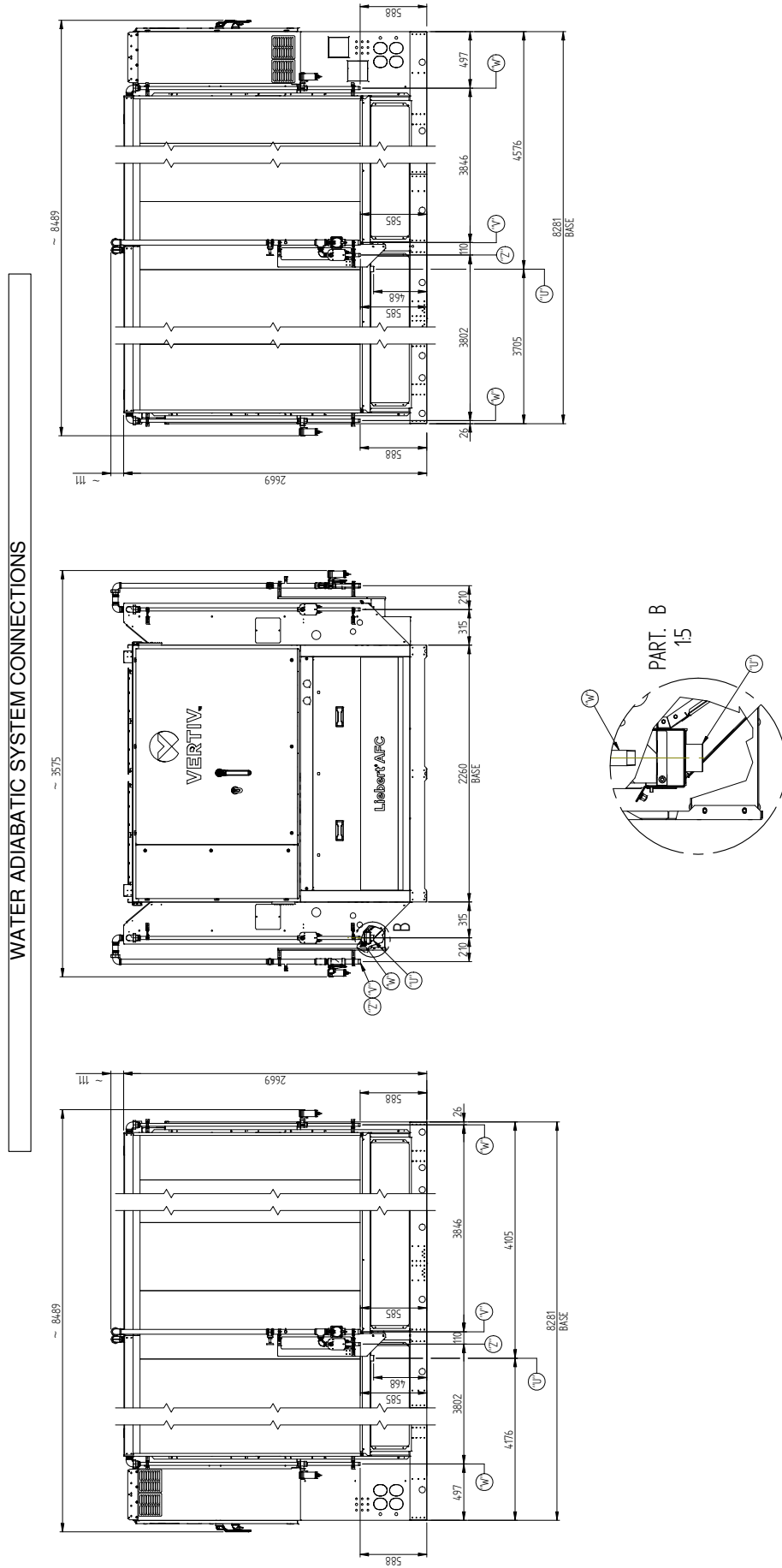

Adiabatic Water connections					
Model	N. Fans	"U"	"V"	"W"	"Z"
FAL 077-089 CAL 077-089	12	Discharge manifold outlet	Water inlet	Side duct circuit outlet	Drainage circuit outlet
		Rp 1.1/4 (ISO 7/1) Female	R 1.1/4 (ISO 7/1) Male	R 3/4 (ISO 7/1) Male	R 3/4 (ISO 7/1) Male







**FIG 9.7 - TRANSPORT OVERALL DIMENSIONS AFC Helical FA/CA 12 Fans WITH INTEGRATED TANKS**

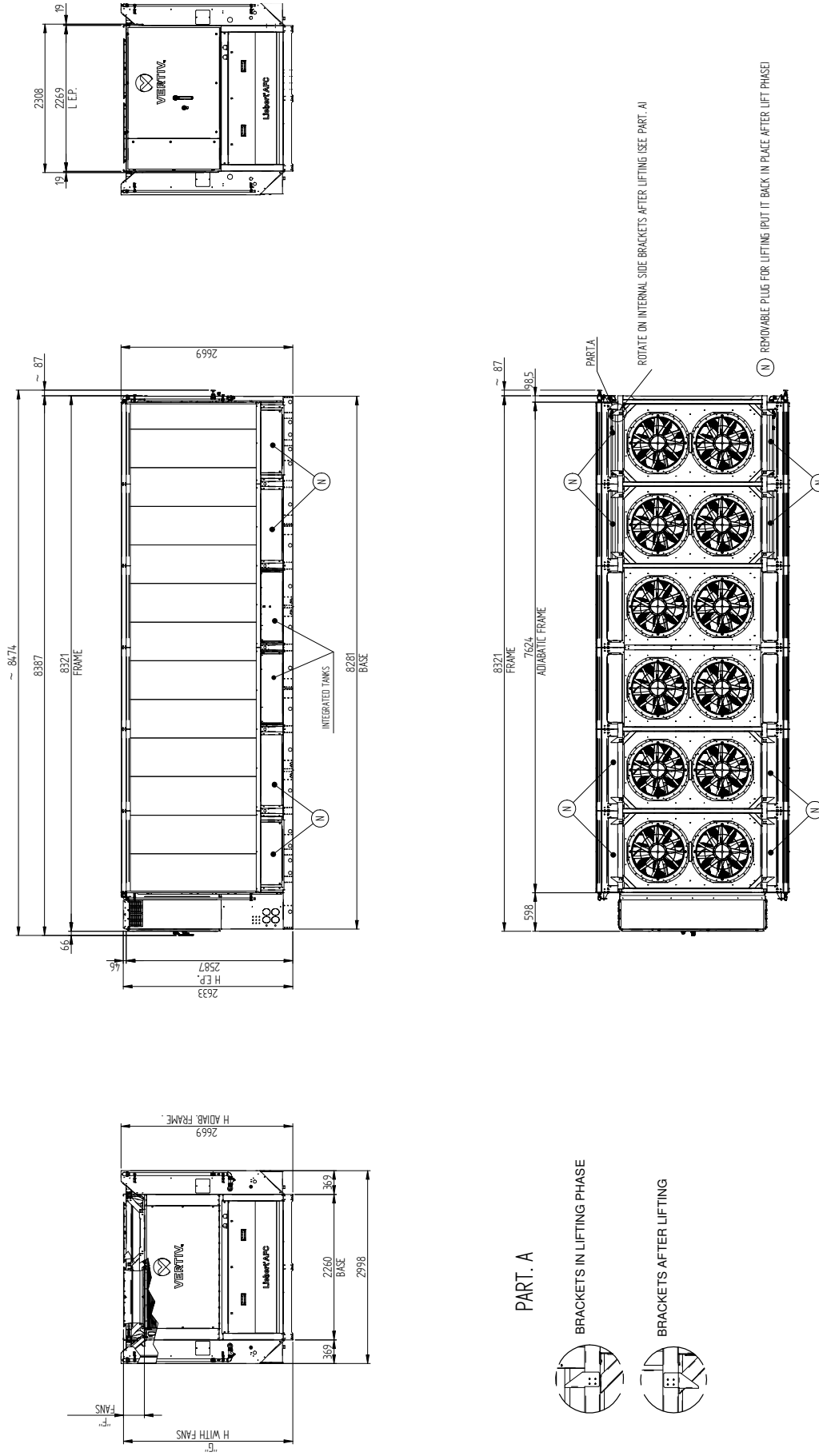

\* For shipment this dimension is reduced of 164mm.

Model	N. Fans	Fans EC diam.800		Fans EC diam.900		AC Fans diam.900	
		F (mm)	G (mm)	F (mm)	G (mm)	F (mm)	G (mm)
FAL 077	12	326	2630	378	2682	-	-
FAL 089	12	-	-	453*	2757*	249	2553





**FIG 9.10 - OVERALL Dimensions AFC Helical FA/CA 14 Fans WITH ADIABATIC**

**WATER ADIABATIC SYSTEM CONNECTIONS**

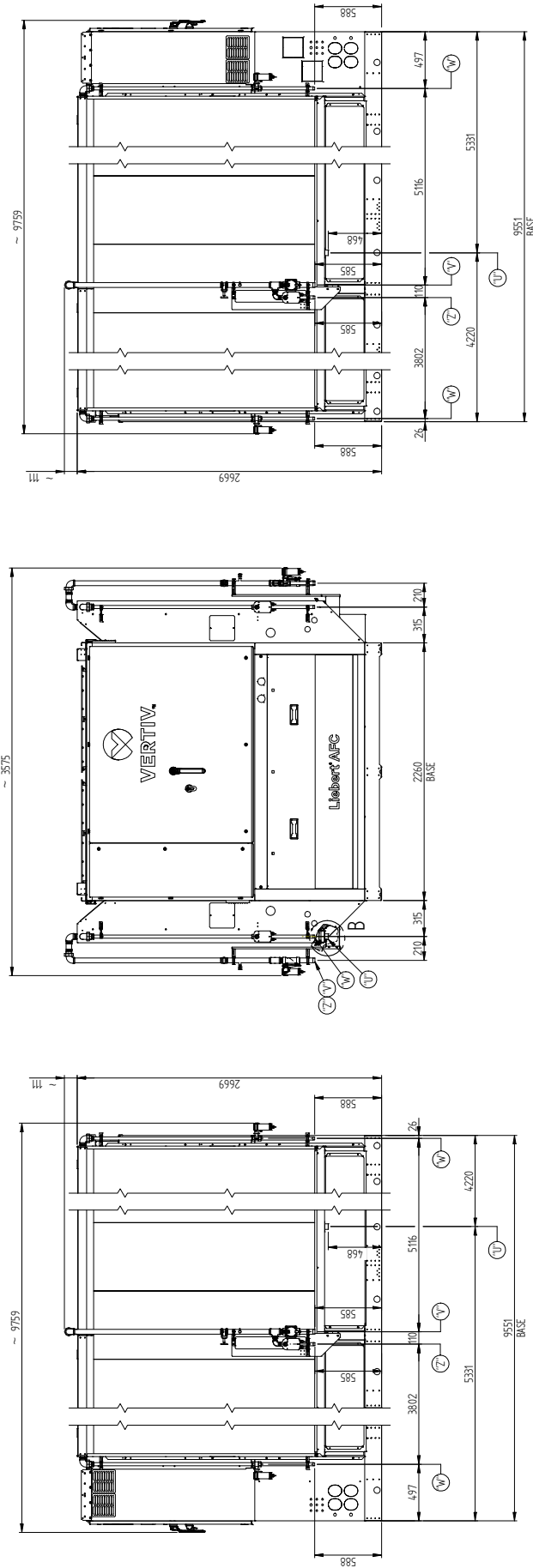

SOME ADIABATIC PIPING SYSTEM ARE SUPPLIED UNMOUNTED (SEE OVERALL TRANSPORT DIMENSIONS)

N. Fans		Adiabatic Water connections			
Model	"U"	"V"	"W"	"Z"	
FA4 088 FAL 101 CAL 101	14	Discharge manifold outlet	Water inlet	R 1.1/4 (ISO 7/1) Male	R 3/4 (ISO 7/1) Male
				Side duct circuit outlet	Drainage circuit outlet
				R 1.1/4 (ISO 7/1) Female	R 3/4 (ISO 7/1) Male



**FIG 9.12 - OVERALL Dimensions AFC Helical FA/CA 14 Fans WITH INTEGRATED TANKS**

WATER ADIABATIC SYSTEM CONNECTIONS

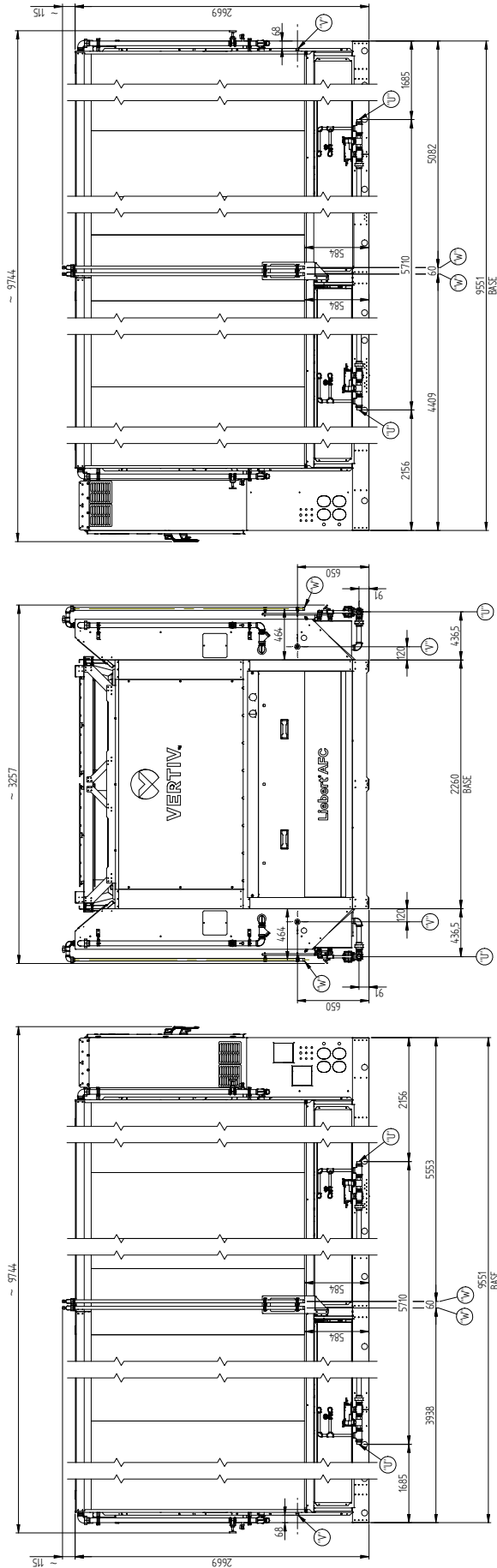

SOME ADIABATIC PIPING SYSTEM ARE SUPPLIED UNMOUNTED (SEE OVERALL TRANSPORT DIMENSIONS)

Model		N. Fans		Adiabatic Water connections		
				"U"	"V"	"W"
FA4 088	FAL 101	14		Tank drainage outlet	G 1.1/4 (ISO 228(1) Male	Water inlet
	CAL 101					R 3/4 (ISO 771) Male
						Central duct circuit outlet
						R 3/4 (ISO 771) Male



**FIG 9.14 - TRANSPORT OVERALL DIMENSIONS AFC Helical FA/CA 14 Fans WITH INTEGRATED TANKS**

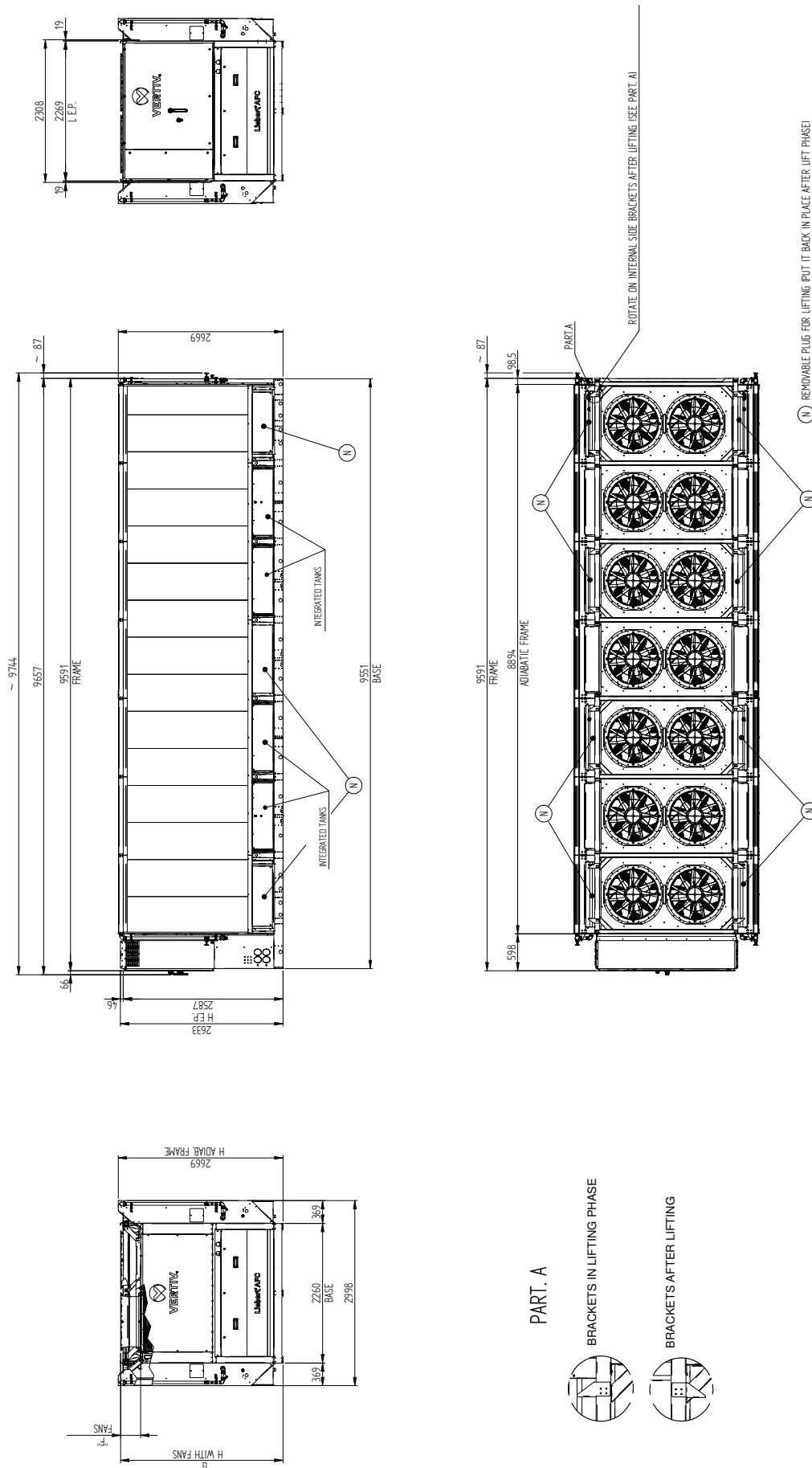

\* For shipment this dimension is reduced of 164mm.

Model	N. Fans	Fans EC diam.800		Fans EC diam.900		AC Fans diam.900	
		F (mm)	G (mm)	F (mm)	G (mm)	F (mm)	G (mm)
FA4 088	14	326	2630	378	2682	-	-
FAL 10z1	14	-	-	453*	2757*	249	2553



**FIG 9.16 - OVERALL Dimensions AFC Helical FA/CA 16 Fans with Adiabatic**

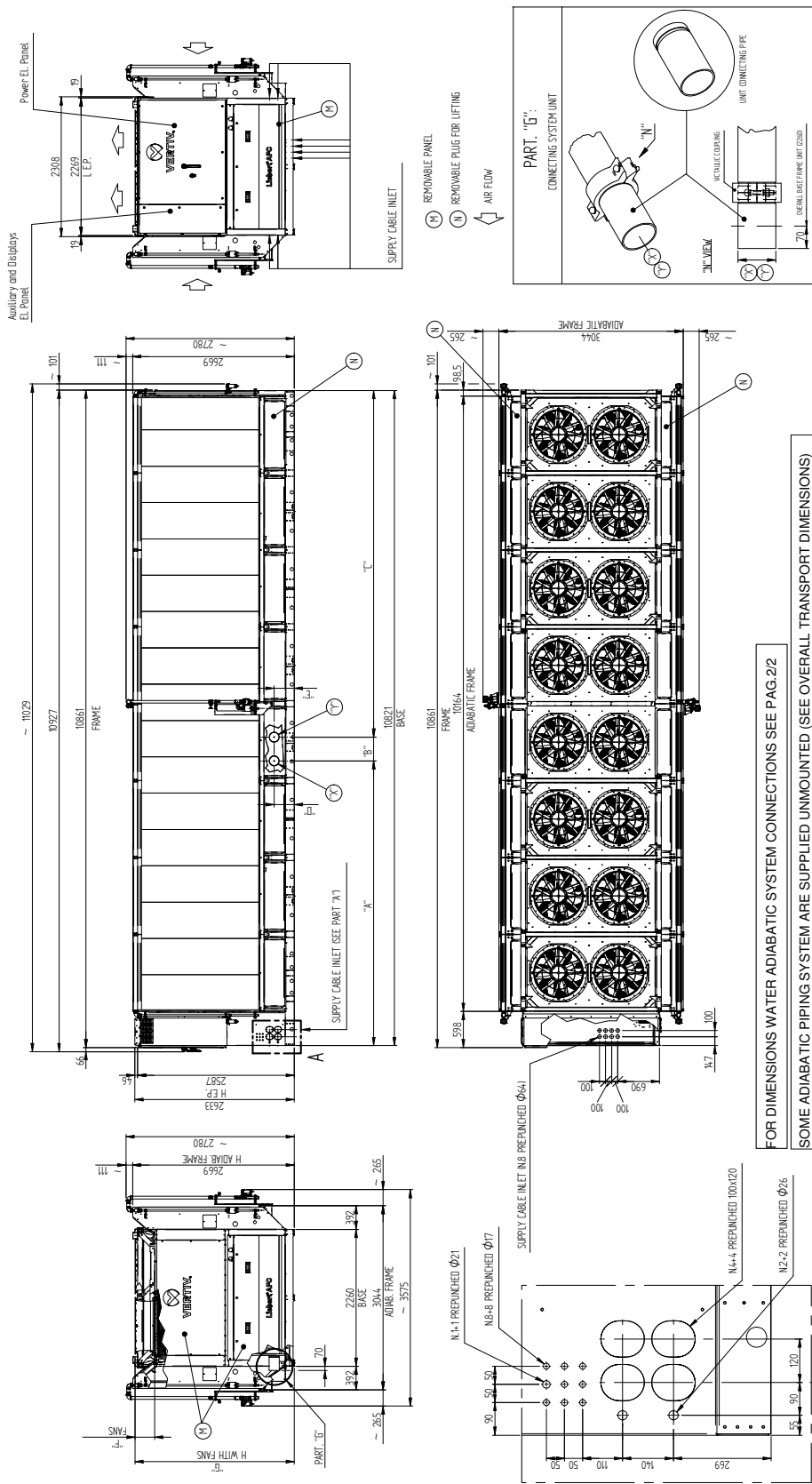

PART A

\* For shipment this dimension is reduced of 164mm.

Model	Version	N. Fans	Fans EC diam.800																Fans EC diam.900				AC Fans diam.900				Chilled Water connections			
			A (mm)	B (mm)	C (mm)	D (mm)	E (mm)	F (mm)	G (mm)	F (mm)	G (mm)	F (mm)	G (mm)	F (mm)	G (mm)	F (mm)	G (mm)	X" (mm)	Y" (mm)	Inlet	Outlet	Inlet	Outlet							
FA4 102	Without Pumps	16	5094	248	5479	332	332	332	326	378	2630	378	2682	-	-	-	-	Outlet	Grooved DN150-6"-168,3	Grooved DN150-6"-168,3	Inlet	Grooved DN150-6"-168,3								
	With Pumps std low press.		4703	391	5727	332	332	332	326	378	2630	378	2682	-	-	-	-	Inlet	Grooved DN150-6"-168,3	Grooved DN150-6"-168,3	Outlet	Grooved DN150-6"-168,3								
	With Pumps high press.		4703	391	5727	332	332	332	326	378	2630	378	2682	-	-	-	-	Inlet	Grooved DN150-6"-168,3	Grooved DN150-6"-168,3	Outlet	Grooved DN150-6"-168,3								
FAL 116	Without Pumps	16	4703	391	5727	332	332	332	326	378	2630	378	2682	-	-	-	-	Outlet	Grooved DN150-6"-168,3	Grooved DN150-6"-168,3	Inlet	Grooved DN150-6"-168,3								
	With Pumps std low press.		5094	300	5427	332	332	332	-	453*	2757*	-	2682	249	2553	249	2553	Outlet	Grooved DN150-6"-168,3	Grooved DN150-6"-168,3	Outlet	Grooved DN150-6"-168,3								
	With Pumps high press.		5094	300	5427	332	332	332	-	453*	2757*	-	2682	249	2553	249	2553	Outlet	Grooved DN150-6"-168,3	Grooved DN150-6"-168,3	Inlet	Grooved DN150-6"-168,3								
CAL 116	Without Pumps	16	5094	300	5427	332	332	332	326	378	2630	378	2682	-	-	-	-	Outlet	Grooved DN150-6"-168,3	Grooved DN150-6"-168,3	Inlet	Grooved DN150-6"-168,3								
	With Pumps std low press.		5094	300	5427	332	332	332	-	453*	2757*	-	2682	249	2553	249	2553	Outlet	Grooved DN150-6"-168,3	Grooved DN150-6"-168,3	Outlet	Grooved DN150-6"-168,3								
	With Pumps high press.		5094	300	5427	332	332	332	-	453*	2757*	-	2682	249	2553	249	2553	Outlet	Grooved DN150-6"-168,3	Grooved DN150-6"-168,3	Inlet	Grooved DN150-6"-168,3								



**FIG 9.18 - OVERALL Dimensions AFC Helical FA/CA 16 Fans WITH INTEGRATED TANKS**

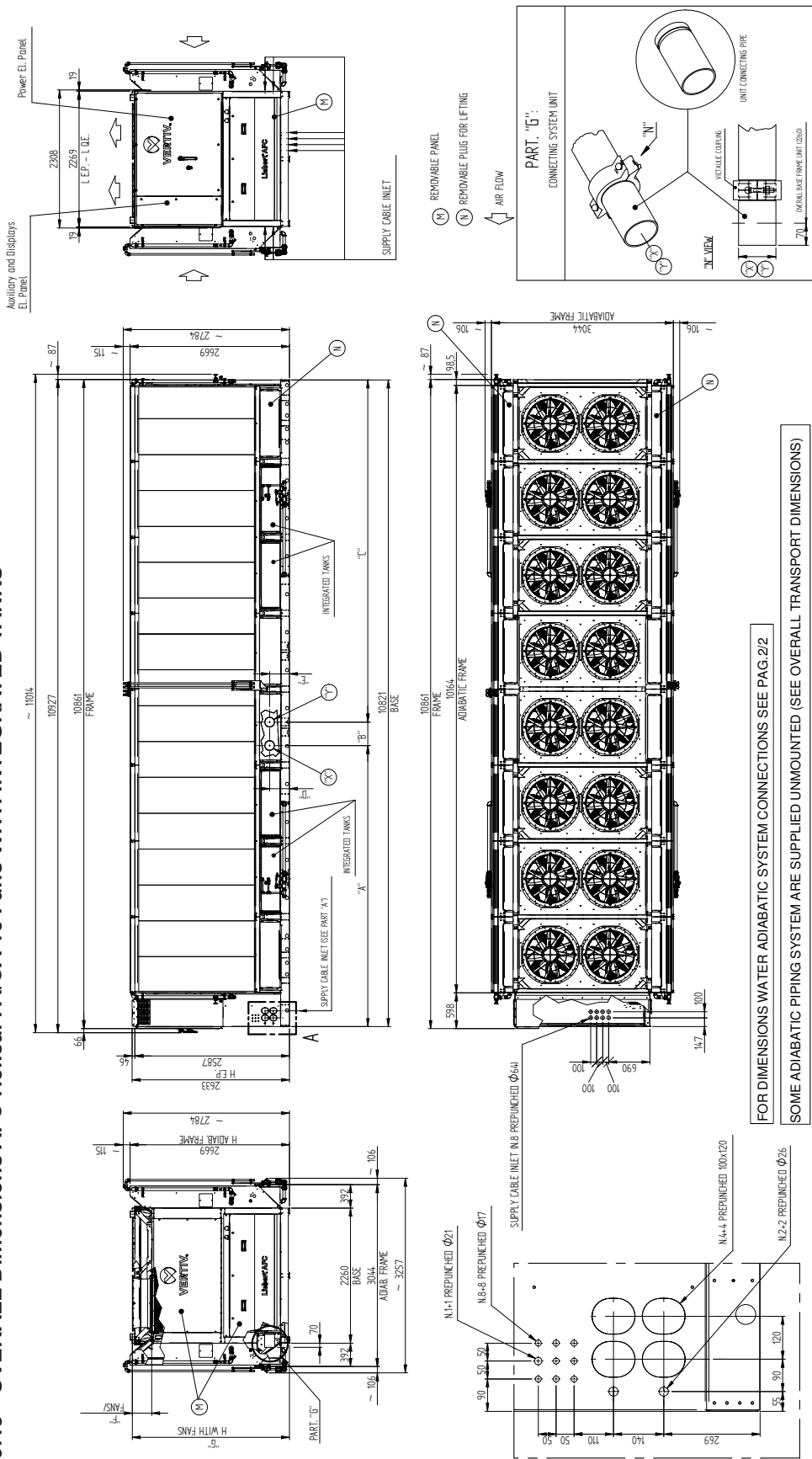

\* For shipment this dimension is reduced of 164mm.

Model	Version	N. Fans	Fans EC diam.800										Fans EC diam.900			AC Fans diam.900			Chilled Water connections		
			A (mm)	B (mm)	C (mm)	D (mm)	E (mm)	F (mm)	G (mm)	F (mm)	G (mm)	F (mm)	G (mm)	"X" (mm)	"Y" (mm)	Inlet	Outlet	Inlet	Outlet	Inlet	Outlet
FA4 102	Without Pumps	16	5094	248	5479	332	332	326	2630	378	2682	-	-	-	-	Outlet	Grooved DN150-6"-168,3	Grooved DN150-6"-168,3	Inlet	Grooved DN150-6"-168,3	
	With Pumps std low press.		4703	391	5727	332	332	326	2630	378	2682	-	-	-	-	Inlet	Grooved DN150-6"-168,3	Grooved DN150-6"-168,3	Outlet	Grooved DN150-6"-168,3	
	With Pumps high press.		4703	391	5727	332	332	326	2630	378	2682	-	-	-	-	Inlet	Grooved DN150-6"-168,3	Grooved DN150-6"-168,3	Outlet	Grooved DN150-6"-168,3	
FAL 116	With Inverter Pump	16	4703	391	5727	332	332	326	2630	378	2682	-	-	-	-	Inlet	Grooved DN150-6"-168,3	Grooved DN150-6"-168,3	Outlet	Grooved DN150-6"-168,3	
	Without Pumps		5094	300	5427	332	332	326	2630	453*	2757*	249	2553	-	-	Outlet	Grooved DN150-6"-168,3	Grooved DN150-6"-168,3	Inlet	Grooved DN150-6"-168,3	
	With Pumps std low press.		4703	391	5727	332	332	326	2630	453*	2757*	249	2553	-	-	Outlet	Grooved DN150-6"-168,3	Grooved DN150-6"-168,3	Inlet	Grooved DN150-6"-168,3	
CAL 116	With Pumps std low press.	16	5094	300	5427	332	332	326	2630	453*	2757*	249	2553	-	-	Outlet	Grooved DN150-6"-168,3	Grooved DN150-6"-168,3	Inlet	Grooved DN150-6"-168,3	
	With Pumps high press.		5094	300	5427	332	332	326	2630	453*	2757*	249	2553	-	-	Outlet	Grooved DN150-6"-168,3	Grooved DN150-6"-168,3	Inlet	Grooved DN150-6"-168,3	
	With Inverter Pump		5094	300	5427	332	332	326	2630	453*	2757*	249	2553	-	-	Outlet	Grooved DN150-6"-168,3	Grooved DN150-6"-168,3	Inlet	Grooved DN150-6"-168,3	

**FIG 9.19 - OVERALL Dimensions AFC Helical FA/CA 16 Fans WITH INTEGRATED TANKS**

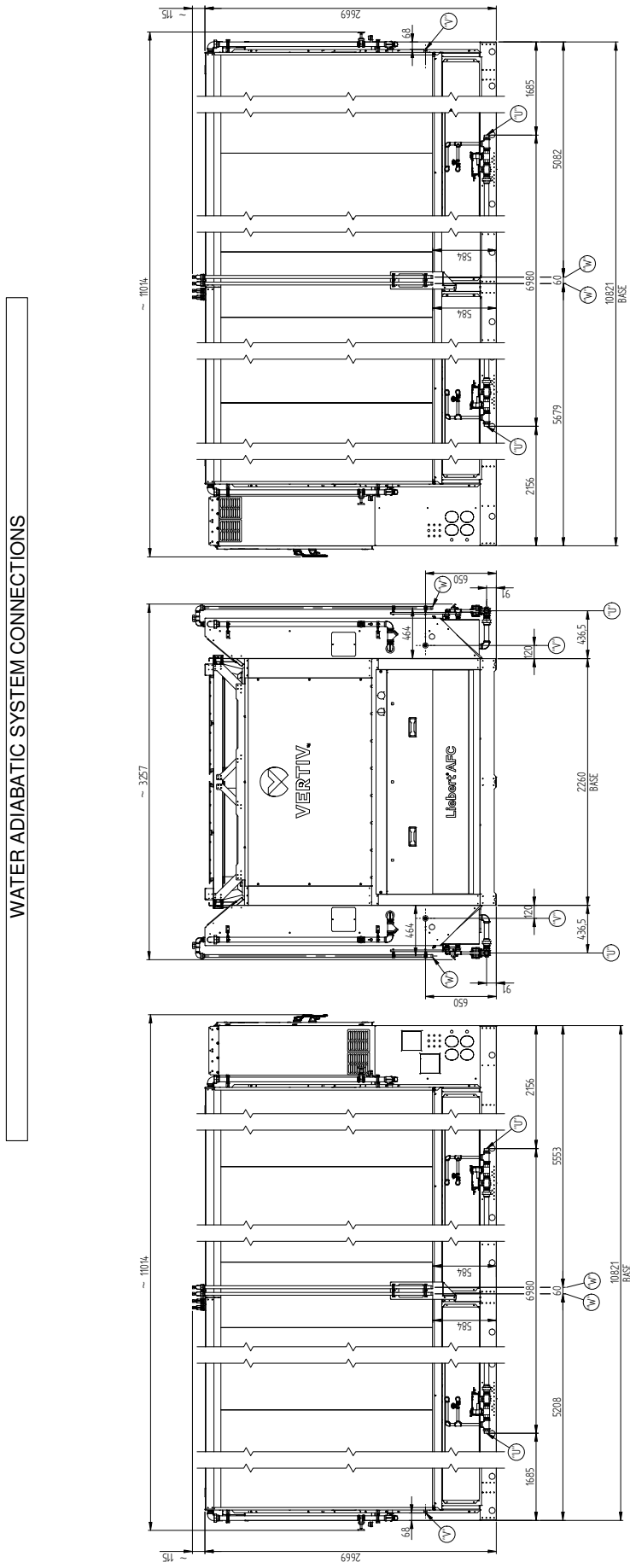

Model		Adiabatic Water connections			
		"U"	"V"	"W"	"X"
FA4 102	N. Fans	Tank drainage outlet	Water inlet	Central duct circuit outlet	R 3/4 (ISO 771) Male
FAL 116	16	G 1. 1/4 (ISO 228/1) Male			
CAL 116					

**FIG 9.20 - TRANSPORT OVERALL DIMENSIONS AFC Helical FA/CA 16 Fans WITH ADIABATIC**

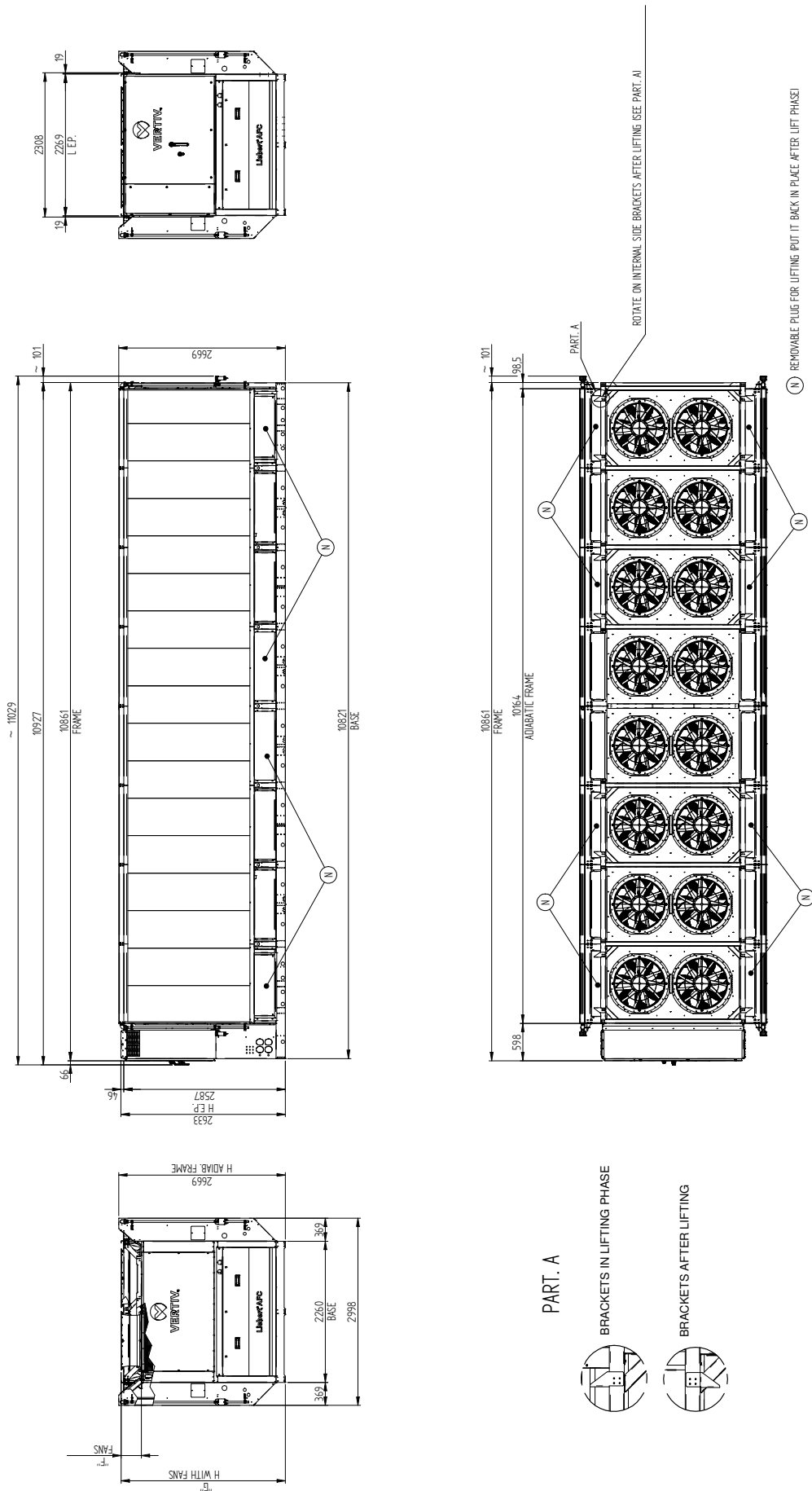

\* For shipment this dimension is reduced of 164mm.

Model	N. Fans	Fans EC diam.800		Fans EC diam.900		AC Fans diam.900	
		F (mm)	G (mm)	F (mm)	G (mm)	F (mm)	G (mm)
FA4 102	16	326	2630	378	2682	-	-
FAL 116	16	-	-	453*	2757*	249	2553

**FIG 9.21 - TRANSPORT OVERALL DIMENSIONS AFC Helical FA/CA 16 Fans WITH INTEGRATED TANKS**

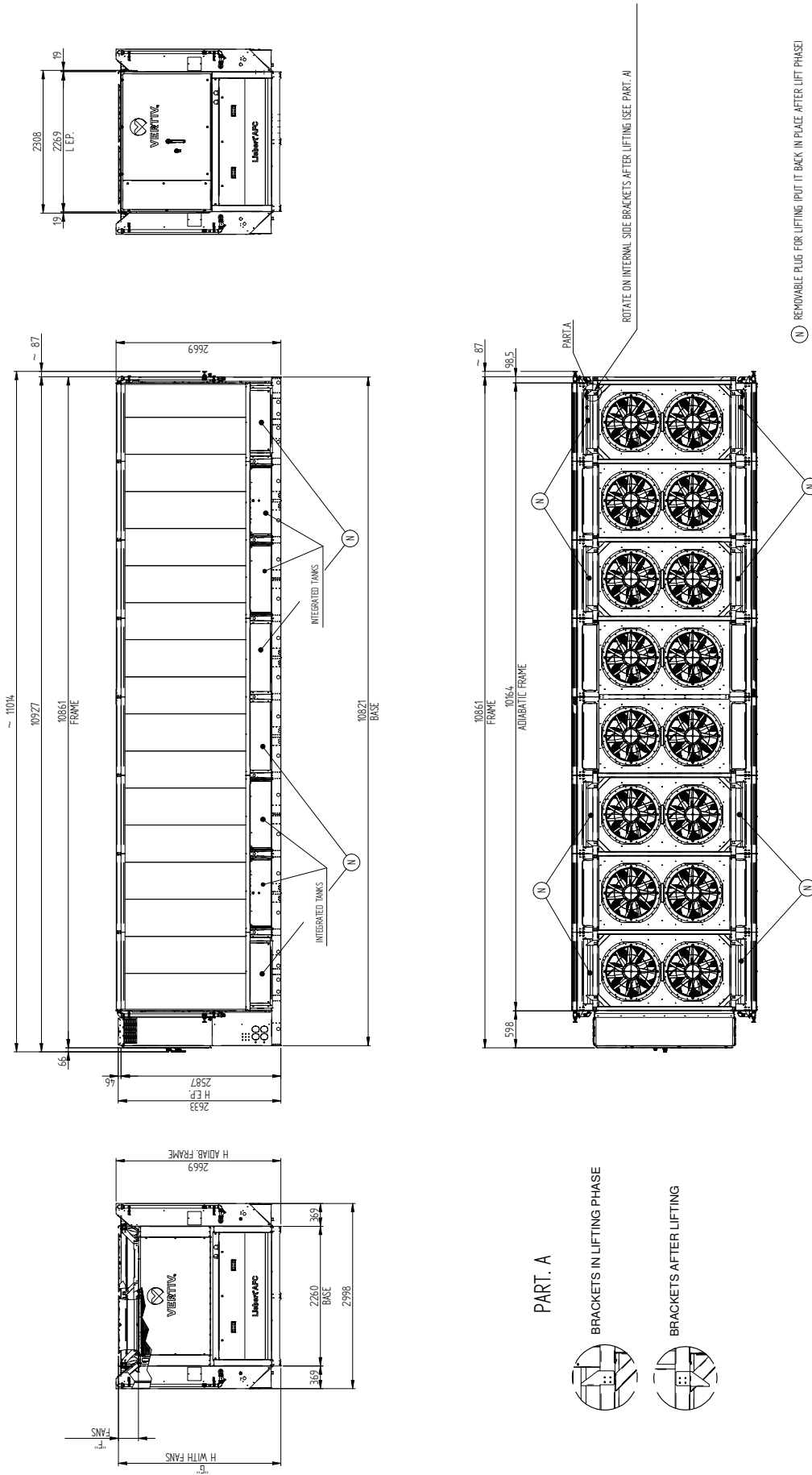

\* For shipment this dimension is reduced of 164mm.

Model	Fans EC diam.800		Fans EC diam.900		AC Fans diam.900	
	N. Fans	F (mm)	G (mm)	F (mm)	G (mm)	F (mm)
FA4 102	16	326	2630	378	2682	-
FAL 116	16	-	453*	2757*	249	2553

**FIG 9.22 - OVERALL DIMENSIONS AFC FD/CD Helical 18 Fans**

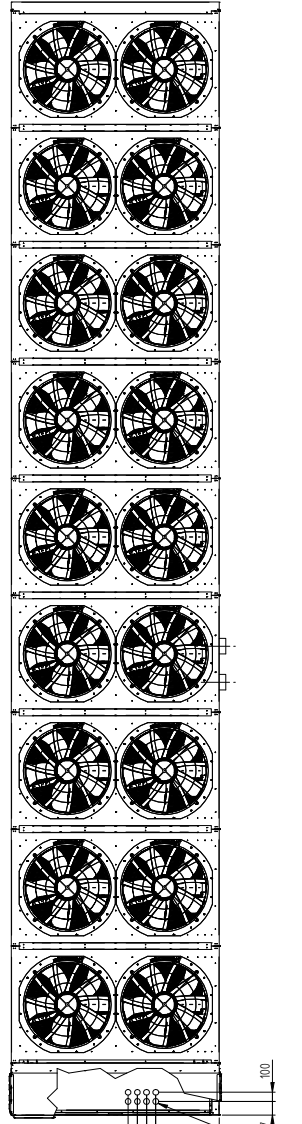
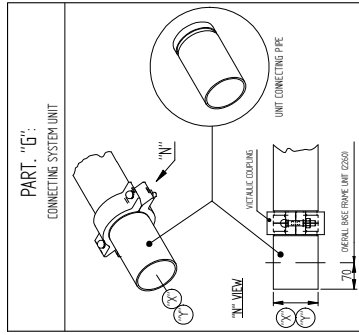
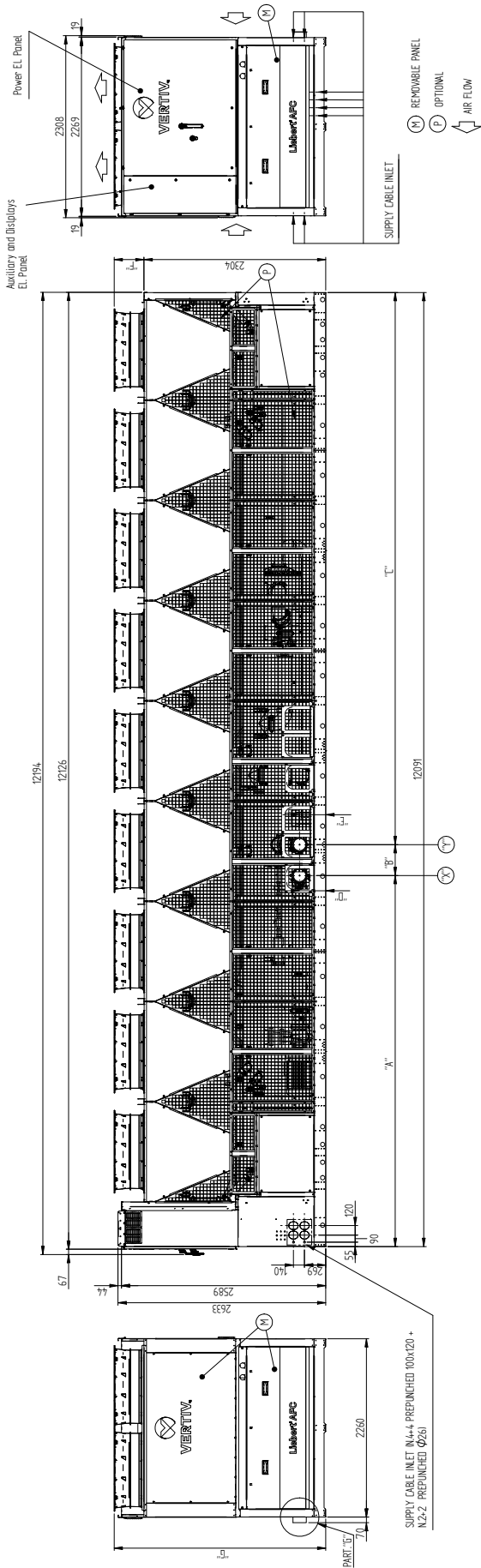

SUPPLY CABLE INLET IN Ø PREPUNCHED Ø64

\* For shipment this dimension is reduced of 164mm.

Model	Version	N. Fans	Fans EC diam.800						Fans EC diam.900			AC Fans diam.900			Chilled Water connections		
			A (mm)	B (mm)	C (mm)	D (mm)	E (mm)	F (mm)	G (mm)	F (mm)	G (mm)	F (mm)	G (mm)	X" (mm)	Y" (mm)	Inlet	Outlet
FD4 117	Without Pumps	18	5094	878	6119	332	332	326	378	2682	-	-	Outlet	Grooved DN150-6"-168,3	Grooved DN150-6"-168,3	Inlet	
	With Pumps std low press.		4703	391	6997	332	332	326	378	2682	-	-	Inlet	Grooved DN200-8"-219,1	Grooved DN200-8"-219,1	Outlet	
	With Pumps high press.		4703	391	6997	332	332	326	378	2682	-	-	Inlet	Grooved DN200-8"-219,1	Grooved DN200-8"-219,1	Outlet	
FDL 127	Without Pumps	18	6364	878	4849	332	332	326	453*	2757*	249	2553	Outlet	Grooved DN200-8"-219,1	Grooved DN200-8"-219,1	Inlet	
	With Pumps std low press.		5973	391	5727	357	332	326	378	2682	-	-	Outlet	Grooved DN200-8"-219,1	Grooved DN200-8"-219,1	Outlet	
	With Pumps high press.		5973	391	5727	357	332	326	378	2682	-	-	Outlet	Grooved DN200-8"-219,1	Grooved DN200-8"-219,1	Outlet	
CDL 127	Without Pumps	18	6364	300	5427	332	332	-	453*	2757*	249	2553	Outlet	Grooved DN200-8"-219,1	Grooved DN200-8"-219,1	Inlet	
	With Pumps std low press.		6364	300	5427	332	332	-	453*	2757*	249	2553	Outlet	Grooved DN200-8"-219,1	Grooved DN200-8"-219,1	Inlet	
	With Pumps high press.		6364	300	5427	332	332	-	453*	2757*	249	2553	Outlet	Grooved DN200-8"-219,1	Grooved DN200-8"-219,1	Inlet	

**FIG 9.23 - OVERALL Dimensions AFC Helical FA/CA 18 Fans WITH ADIABATIC**

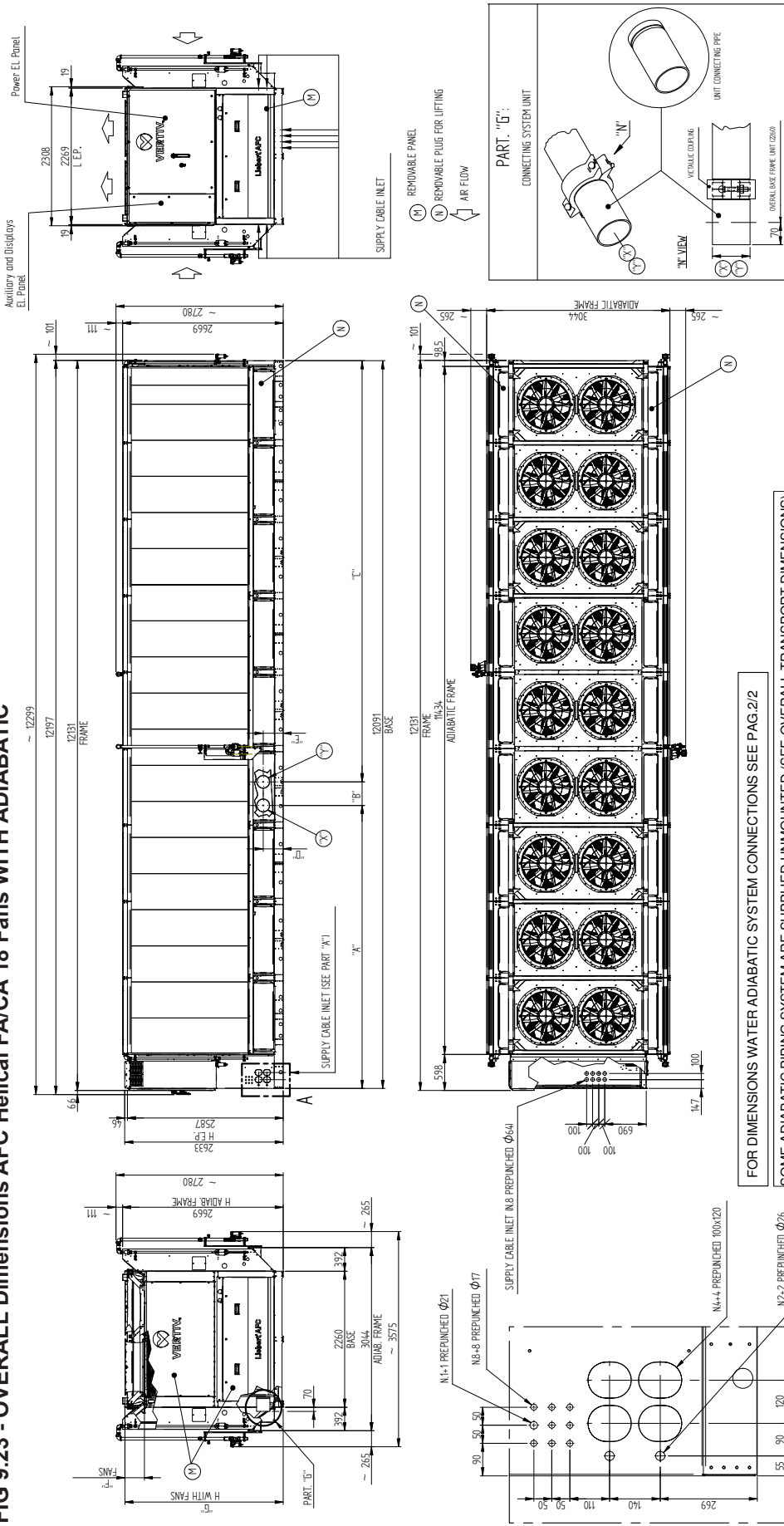

PART. A

Model	Version	N. Fans	A (mm)	B (mm)	C (mm)	D (mm)	E (mm)	F (mm)	G (mm)	Fans EC diam.800 (mm)	Fans EC diam.900 (mm)	F (mm)	G (mm)	AC Fans diam.900 (mm)	X" (mm)	Y" (mm)	Chilled Water connections	
FA4 117	Without Pumps	18	5094	878	6119	332	332	326	2630	378	2682	378	2682	-	Outlet	Outlet	Inlet	Grooved DN150-6"
	With Pumps std low press.		4703	391	6997	332	332	326	2630	378	2682	378	2682	-	Inlet	Outlet	Outlet	Outlet
	With Pumps high press.		4703	391	6997	332	332	326	2630	378	2682	378	2682	-	Inlet	Outlet	Outlet	Outlet
FAL 127	Without Pumps	18	6364	878	4849	332	332	326	2630	378	2682	378	2682	-	Outlet	Outlet	Inlet	Grooved DN200-8"
	With Pumps std low press.		5973	391	5727	357	332	326	2630	378	2682	378	2682	-	Inlet	Outlet	Outlet	Outlet
	With Pumps high press.		5973	391	5727	357	332	326	2630	378	2682	378	2682	-	Inlet	Outlet	Outlet	Outlet
CAL 127	Without Pumps	18	6364	300	5427	332	332	326	2630	453*	2757*	453*	2757*	249	Outlet	Outlet	Inlet	Grooved DN200-8"
	With Pumps std low press.		6364	300	5427	332	332	326	2630	453*	2757*	453*	2757*	249	Outlet	Outlet	Inlet	Grooved DN200-8"
	With Pumps high press.		6364	300	5427	332	332	326	2630	453*	2757*	453*	2757*	249	Outlet	Outlet	Inlet	Grooved DN200-8"
	With Inverter Pump		6364	300	5427	332	332	326	2630	453*	2757*	453*	2757*	249	Outlet	Outlet	Inlet	Grooved DN200-8"

**FIG 9.24 - OVERALL Dimensions AFC Helical FA/CA 18 Fans WITH ADIABATIC**

WATER ADIABATIC SYSTEM CONNECTIONS

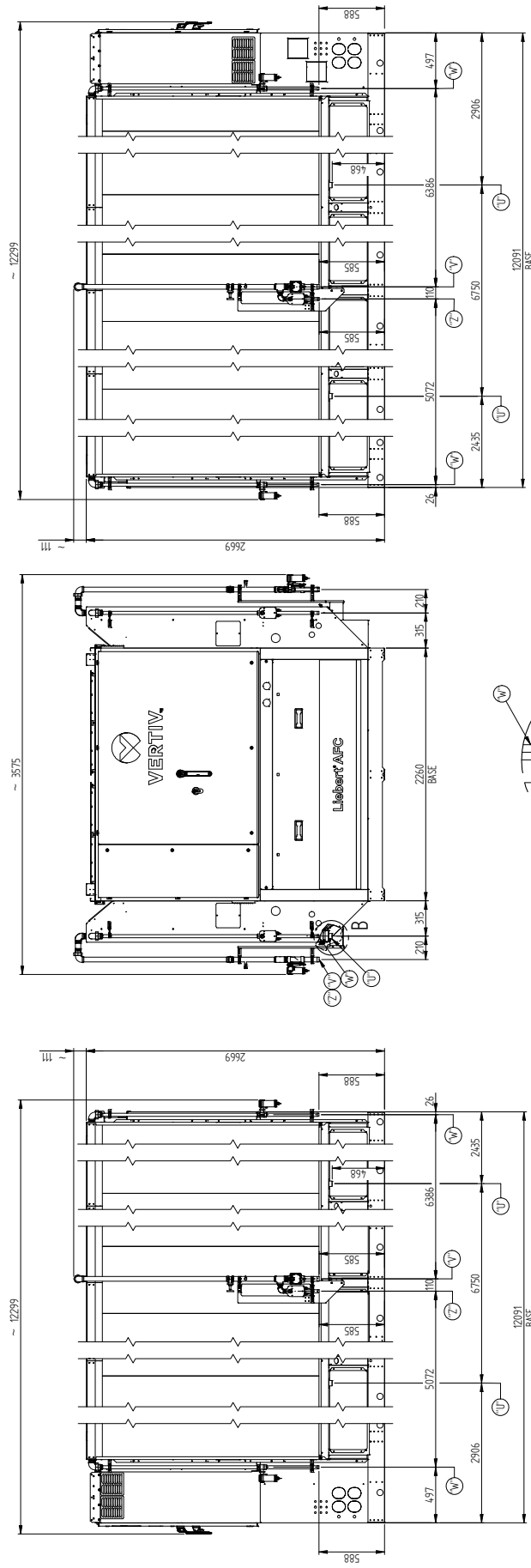

SOME ADIABATIC PIPING SYSTEM ARE SUPPLIED UNMOUNTED (SEE OVERALL TRANSPORT DIMENSIONS)

Model		N. Fans		Adiabatic Water connections			
FA4 117 FAL 127 CAL 127		18		"U"	"V"	"Z"	
		Discharge manifold outlet	Rp 1.1/4 (ISO 7/1) Female	Water inlet	R 1.1/4 (ISO 7/1) Male	Drainage circuit outlet	R 3/4 (ISO 7/1) Male
				Side duct circuit outlet	R 3/4 (ISO 7/1) Male		





**FIG 9.27 - TRANSPORT OVERALL DIMENSIONS AFC Helical FA/CA 18 Fans WITH ADIABATIC**

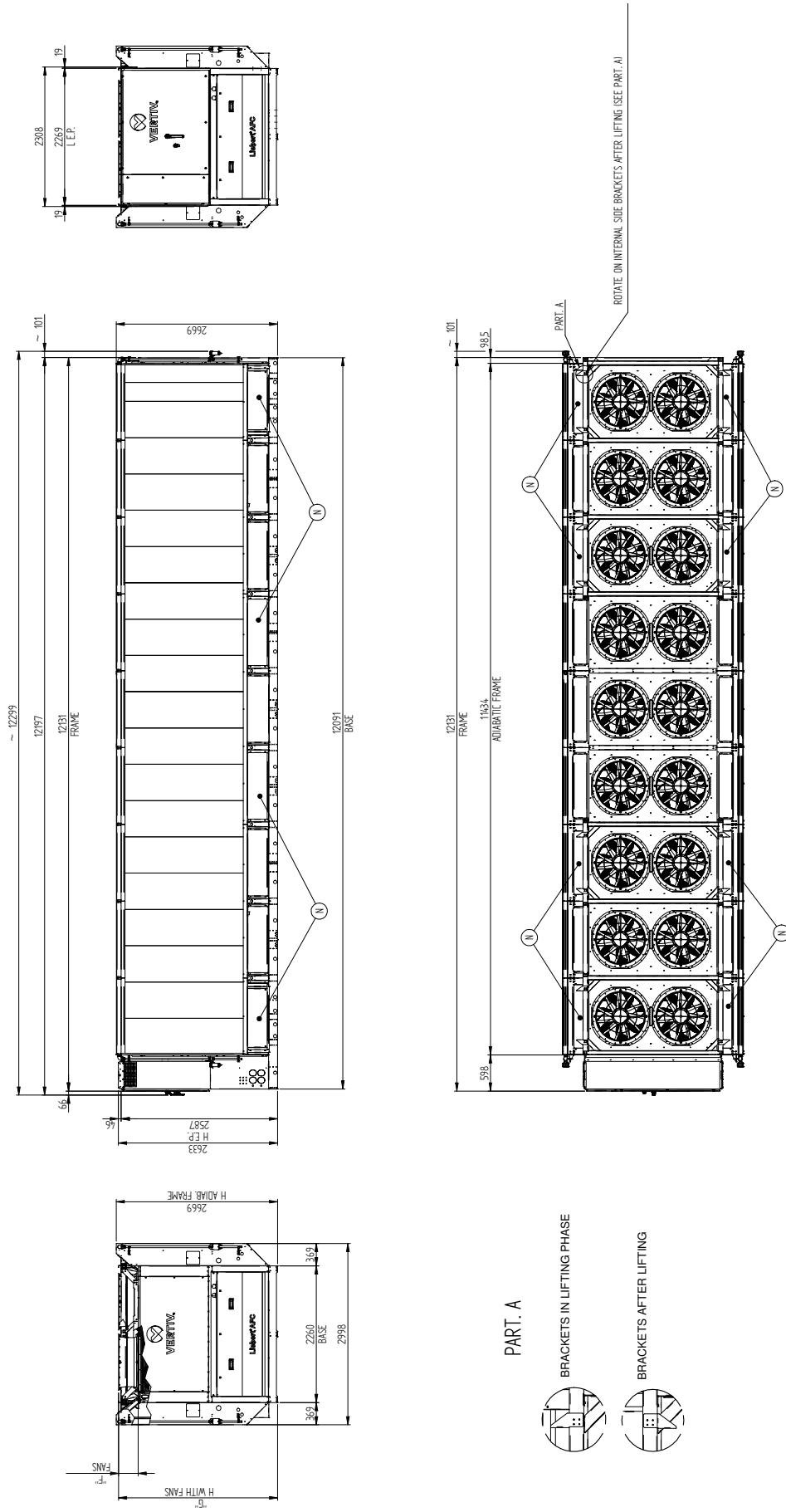

\* For shipment this dimension is reduced of 164mm.

Model	N. Fans	Fans EC diam.800		Fans EC diam.900		AC Fans diam.900	
		F (mm)	G (mm)	F (mm)	G (mm)	F (mm)	G (mm)
FA4 117	18	326	2630	378	2682	-	-
FAL 127	18	-	-	453*	2757*	249	2553

**FIG 9.28 - TRANSPORT OVERALL DIMENSIONS AFC Helical FA/CA 18 Fans WITH INTEGRATED TANKS**

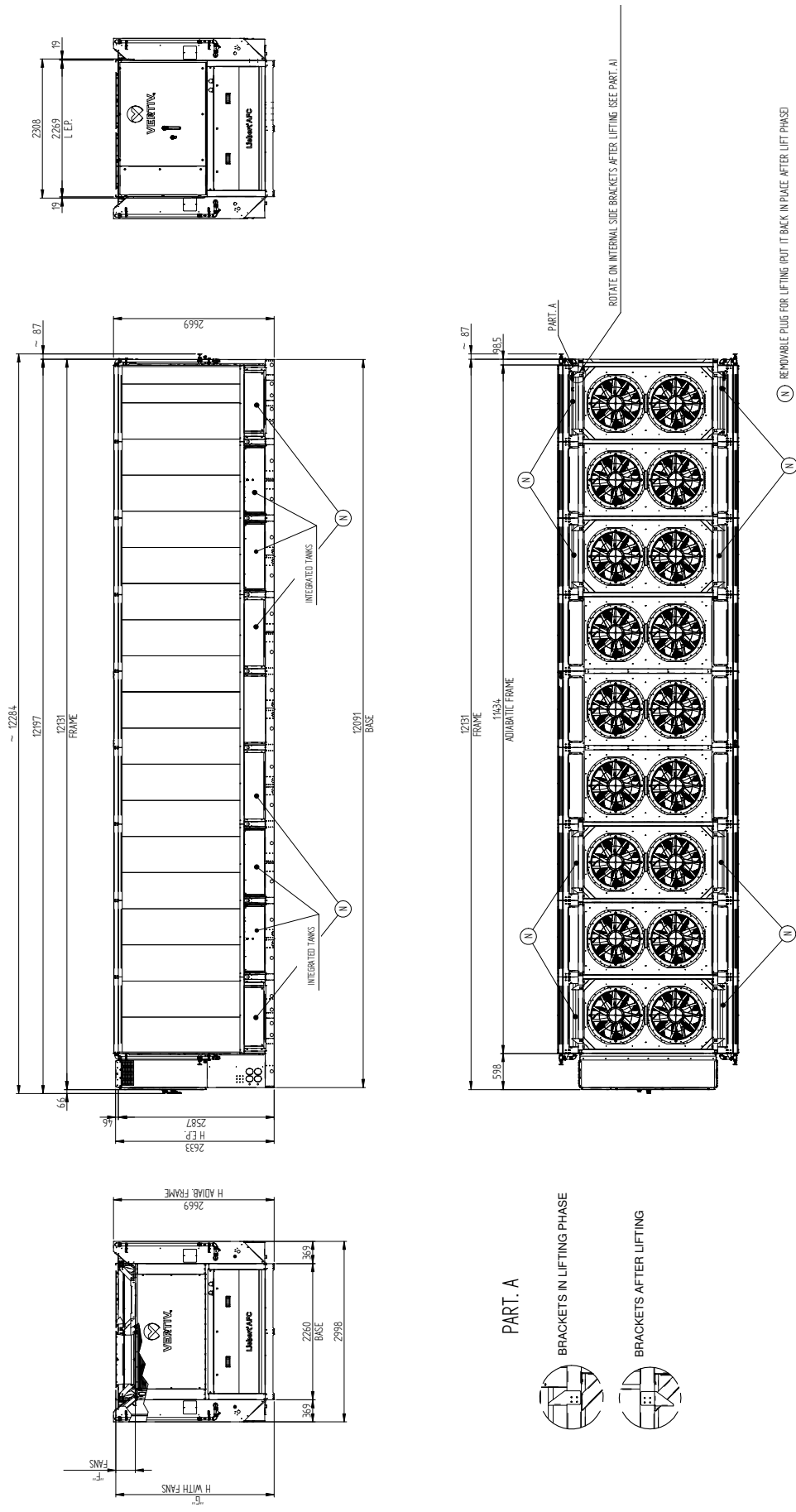

\* For shipment this dimension is reduced of 164mm.

Model	N. Fans	Fans EC diam.800		Fans EC diam.900		AC Fans diam.900	
		F (mm)	G (mm)	F (mm)	G (mm)	F (mm)	G (mm)
FA4 117	18	326	2630	378	2682	-	-
FAL 127	18	-	-	453*	2757*	249	2553

**FIG 9.29 - OVERALL Dimensions AFC FD/CD Helical 20 Fans**

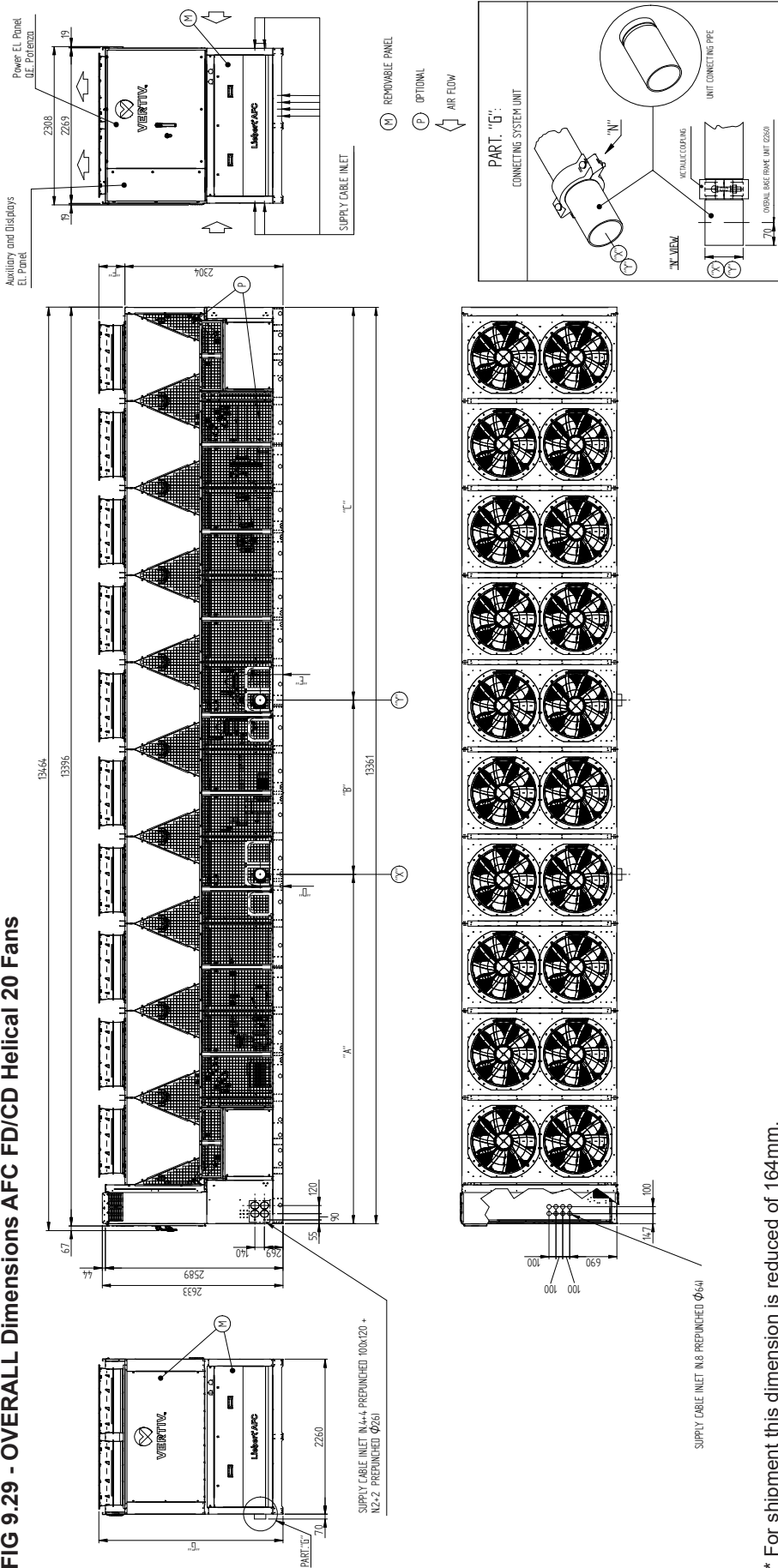

Model	Version	N. Fans	Fans EC diam.800										Fans EC diam.900			AC Fans diam.900			Chilled Water connections		
			A (mm)	B (mm)	C (mm)	D (mm)	E (mm)	F (mm)	G (mm)	F (mm)	G (mm)	F (mm)	G (mm)	F (mm)	G (mm)	"X" (mm)	"Y" (mm)				
FD4 130	Without Pumps	20	7242	392	5727	332	332	326	2630	378	2682	-	-	-	-	Inlet	Outlet	Grooved DN150-6"-168,3			
	With Pumps std low press.		5094	2540	5727	332	332	326	2630	378	2682	-	-	-	Inlet	Outlet	Grooved DN150-6"-168,3				
	With Pumps high press.		5094	2540	5727	332	332	326	2630	378	2682	-	-	-	Inlet	Outlet	Grooved DN150-6"-168,3				
FD4 145	With Inverter Pump	20	5094	2540	5727	332	332	326	2630	378	2682	-	-	-	Inlet	Outlet	Grooved DN200-8"-219,1				
	Without Pumps		7242	392	5727	332	332	326	2630	378	2682	-	-	-	Inlet	Outlet	Grooved DN200-8"-219,1				
	With Pumps std low press.		5094	2540	5727	357	332	326	2630	378	2682	-	-	-	Inlet	Outlet	Grooved DN200-8"-219,1				
FD4 160	With Pumps high press.	20	5094	2540	5727	357	332	326	2630	378	2682	-	-	-	Inlet	Outlet	Grooved DN200-8"-219,1				
	Without Pumps		7242	392	5727	332	332	326	2630	378	2682	-	-	-	Inlet	Outlet	Grooved DN200-8"-219,1				
	With Pumps std low press.		5094	2540	5727	357	332	326	2630	378	2682	-	-	-	Inlet	Outlet	Grooved DN200-8"-219,1				
CDL 138	With Inverter Pump	20	7634	300	5427	332	332	453*	2757*	249	2553	249	2553	249	2553	Inlet	Inlet	Grooved DN200-8"-219,1			
	Without Pumps		7634	300	5427	332	332	453*	2757*	249	2553	249	2553	249	2553	Inlet	Inlet	Grooved DN200-8"-219,1			
	With Pumps std low press.		7634	300	5427	332	332	453*	2757*	249	2553	249	2553	249	2553	Inlet	Inlet	Grooved DN200-8"-219,1			

\* For shipment this dimension is reduced of 164mm.



**FIG 9.31 - OVERALL Dimensions AFC Helical FA/CA 20 Fans WITH ADIABATIC**

**WATER ADIABATIC SYSTEM CONNECTIONS**

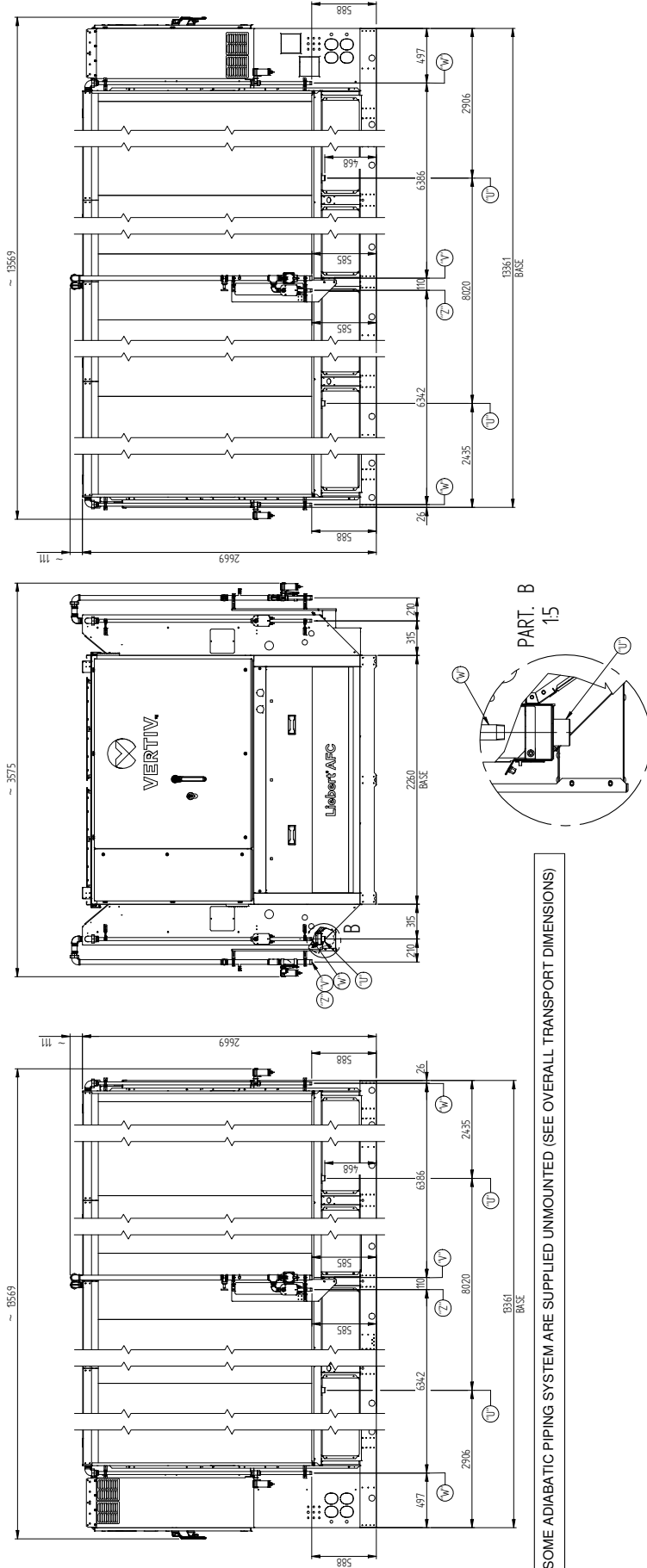

SOME ADIABATIC PIPING SYSTEM ARE SUPPLIED UNMOUNTED (SEE OVERALL TRANSPORT DIMENSIONS)

Model		N. Fans		Adiabatic Water connections		
		"U"		"W"		"Z"
FA4 130		Discharge manifold outlet	Water inlet	Side duct circuit outlet	Drainage circuit outlet	R 3/4 (ISO 7/1) Male
FA4 10X	20	Rp 1.1/4 (ISO 7/1) Female	R 1.1/4 (ISO 7/1) Male	R 3/4 (ISO 7/1) Male		
FA4 145						
FA4 160						
FAL 138						
CAL 138						

**FIG 9.32 - OVERALL DIMENSIONS AFC Helical FA/CA 20 Fans WITH INTEGRATED TANKS**

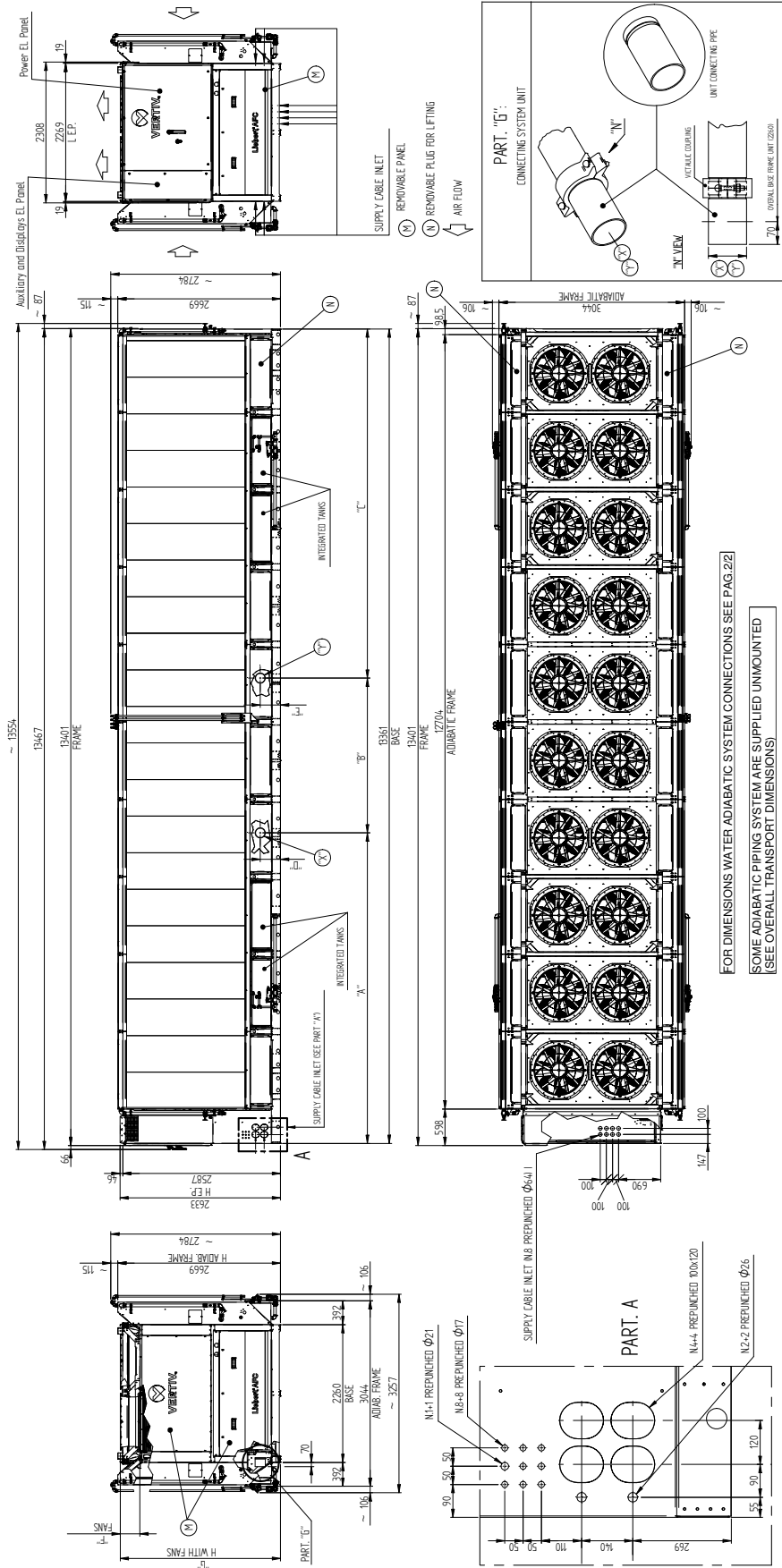

\* For shipment this dimension is reduced of 164mm.

Model	Version	N. Fans	Fans EC diam.800										AC Fans diam.900			Chilled Water connections		
			A (mm)	B (mm)	C (mm)	D (mm)	E (mm)	F (mm)	G (mm)	F (mm)	G (mm)	F (mm)	G (mm)	"X" (mm)	"Y" (mm)			
FA4 130	Without Pumps	20	7242	392	5727	332	332	326	2630	378	2682	-	-	Inlet	Grooved DN150-6"	Outlet	Grooved DN150-6"	
	With Pumps std low press.		5094	2540	5727	332	332	326	2630	378	2682	-	-	Inlet	Grooved DN150-6"	Outlet	Grooved DN150-6"	
FA4 145	Without Pumps	20	7242	392	5727	332	332	326	2630	378	2682	-	-	Inlet	Grooved DN200-8"	Outlet	Grooved DN200-8"	
	With Pumps std low press.		5094	2540	5727	357	332	326	2630	378	2682	-	-	Inlet	Grooved DN200-8"	Outlet	Grooved DN200-8"	
CAL 138	Without Pumps	20	7634	300	5427	332	332	-	-	453*	2757*	249	2553	Outlet	Grooved DN200-8"	Inlet	Grooved DN200-8"	
	With Pumps std low press.		7634	300	5427	332	332	-	-	453*	2757*	249	2553	Outlet	Grooved DN200-8"	Inlet	Grooved DN200-8"	
CAL 138	Without Pumps	20	7634	300	5427	332	332	-	-	453*	2757*	249	2553	Outlet	Grooved DN200-8"	Inlet	Grooved DN200-8"	
	With Pumps high press.		7634	300	5427	332	332	-	-	453*	2757*	249	2553	Outlet	Grooved DN200-8"	Inlet	Grooved DN200-8"	



**FIG 9.34 - TRANSPORT OVERALL DIMENSIONS AFC Helical FA/CA 20 Fans WITH ADIABATIC**

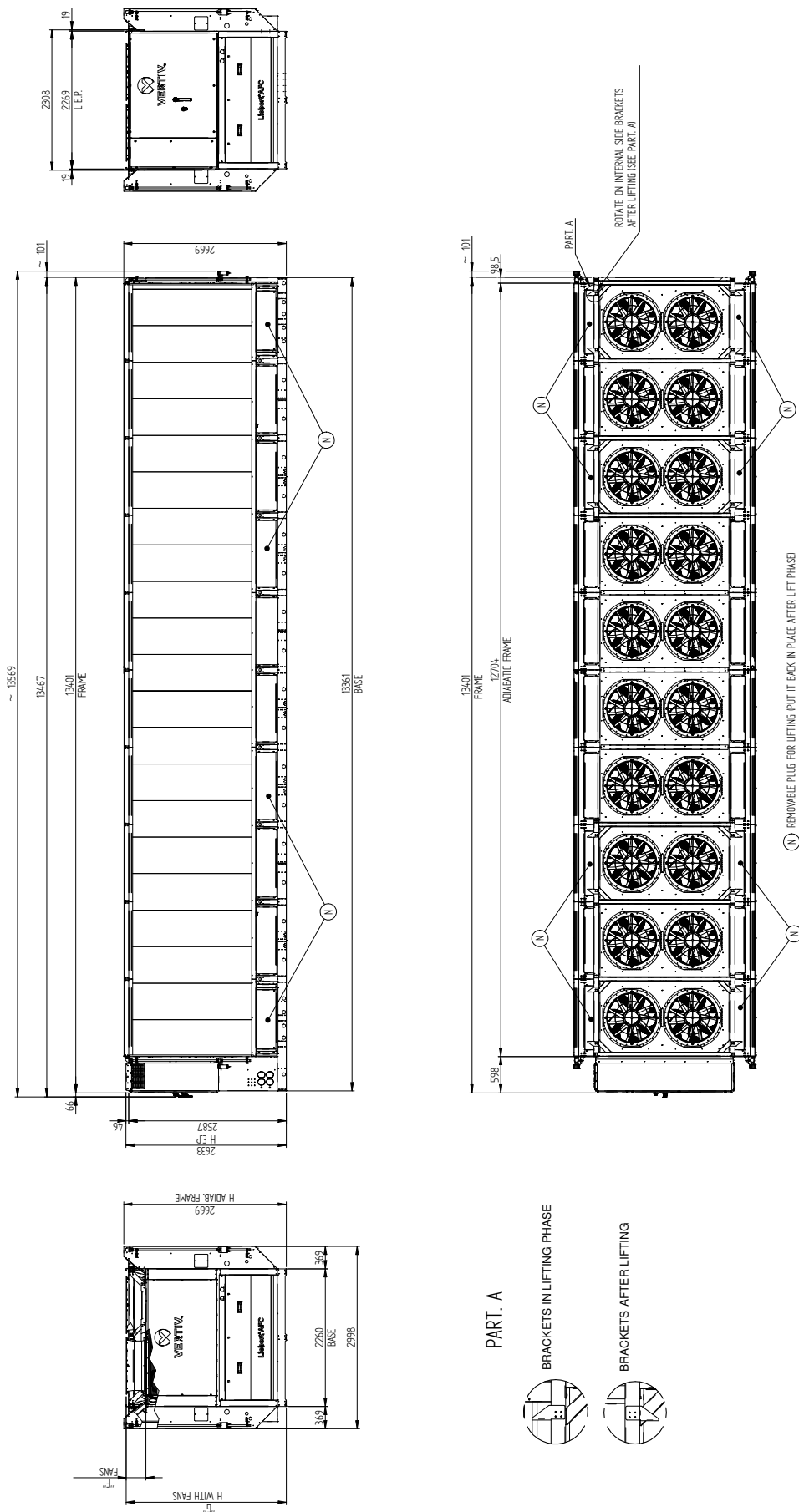

\* For shipment this dimension is reduced of 164mm.

Model	N. Fans	Fans EC diam.800		Fans EC diam.900		AC Fans diam.900	
		F (mm)	G (mm)	F (mm)	G (mm)	F (mm)	G (mm)
FA4 130							
FA4 10X	20	326	2630	378	2682	-	-
FA4 145							
FA4 160							
FAL 138							
CAL 138	20	-	-	453*	2757*	249	2553



FIG 9.36 - OVERALL UNIT Dimensions WITH LIFTING TUBES OPTION (FD AND FA WITH ADIABATIC NOT ASSEMBLED IN VERTIV)

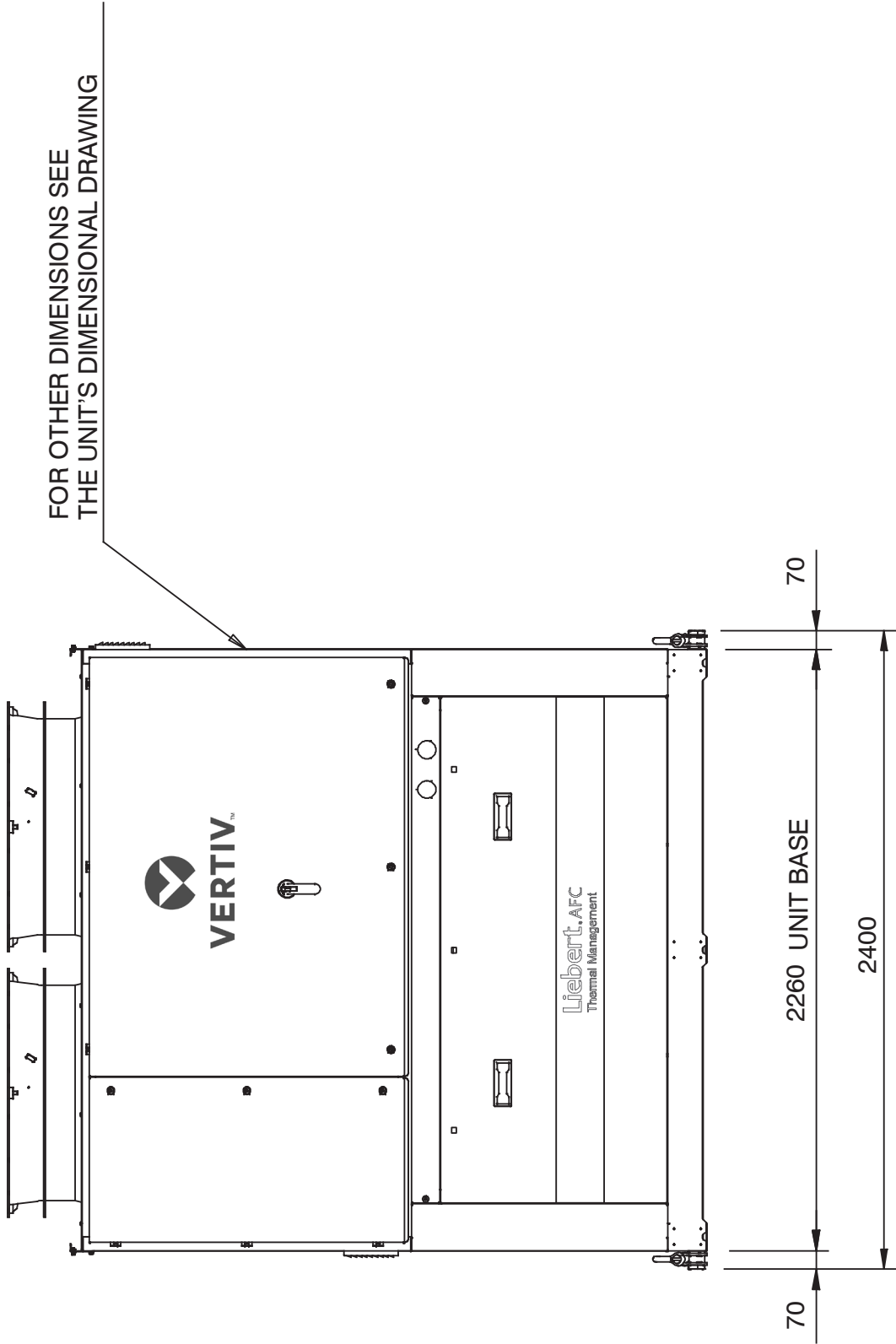

**FIG 9.37 - ELECTRICAL PANEL PROTECTION ROOF ASSEMBLY (OPT.)**

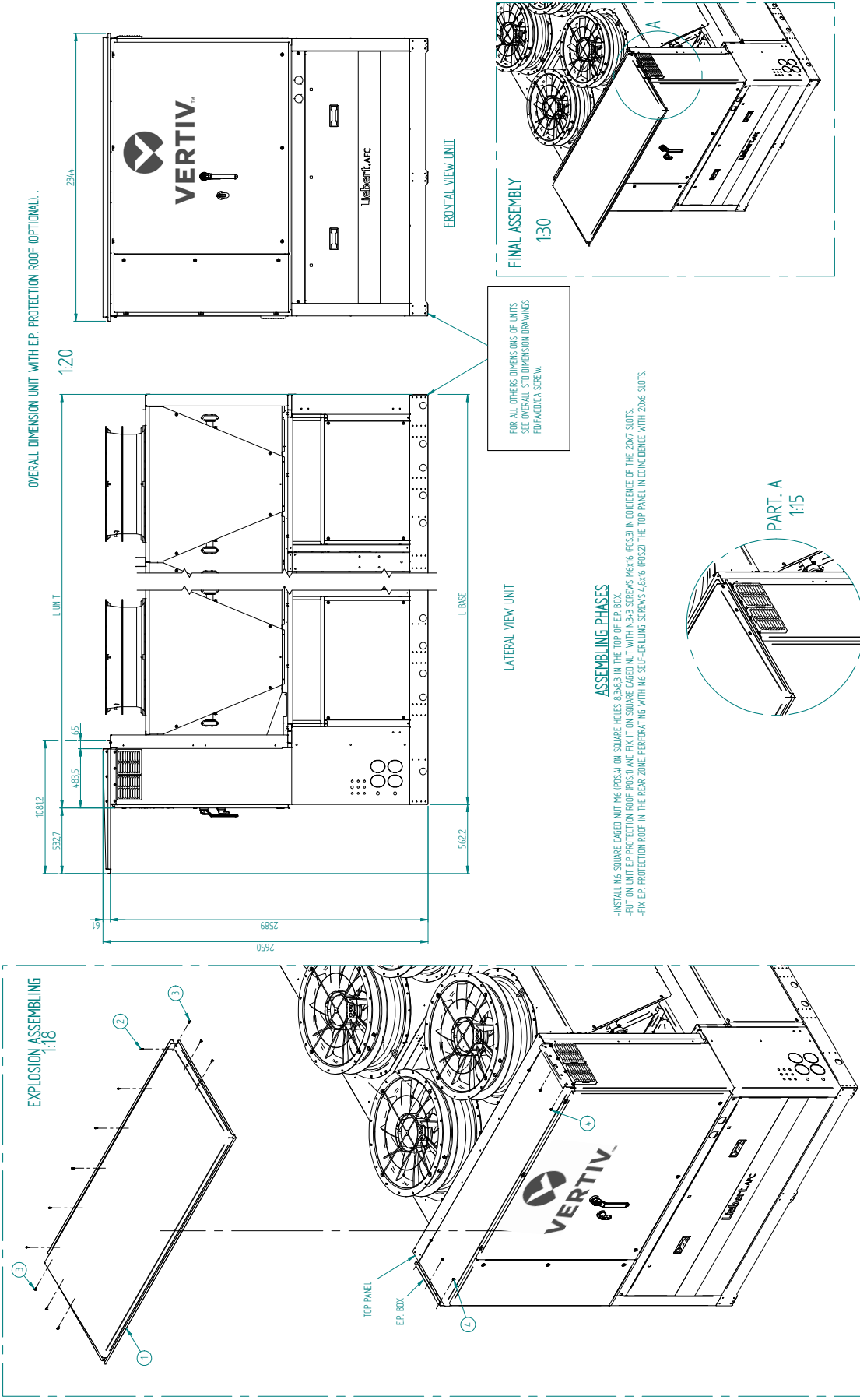

Pos.	Description	Cod. VERTIV™	Draw./Dis.	Note	Quant.
1	LARGER E.P. PROTECTION ROOF	137487	EK1000C209		1
2	HEXAGONAL HEAD SELF-DRILLING HELICAL WITH COLLAR 4.8X16 GALV.	390230		UNI 8117 - MAT.:C15	6
3	SERRATED HEXAGON FLANGE HELICAL M6x16 GALV.	391340		DIN6921 - CL.8.8	6
4	SQUARE CAGED NUT GALV. (2.6-3.5mm)	117333		ART.M6CX83 - 5116C (8.3x8.3)	6

**Tab. 9.38- WATER BUILT-IN TANKS**

AFC fan [No]	PAD [No] *	Number of tanks for side [No]	Nominal volume of tanks for single side [l]	Max volume of tanks for single side [l]	Total single side system volume [l]
6	12+	1	100	150	147
8	16+	2	200	300	261
10	21+	2	200	300	272
12	25+	2	200	300	284
14	29+	4	400	600	511
16	33+	4	400	600	522
18	38+	4	400	600	533
20	42+	4	400	600	545

\*. PAD section already to be cut to cover the whole lenght

**Legend**

**Nominal volume of tanks for single side:** water volume contained in all tanks for side, from the bottom to the level of the float cock. This is the water volume usually present in the tank while the System adiabatic is operating.

**Max. volume of tanks for single side:** water volume contained in all tanks for side, from the bottom to the overflow level. This is the max. volume that can be contained in the entire System adiabatic (tanks, hydraulic circuit, lower channel, water in the pads...)

**Total single side system volume:** water volume contained in the entire System adiabatic (tanks, hydraulic circuit, lower channel, water in the pad...)



Fig. 10b - FREE-COOLING REFRIGERANT DIAGRAM

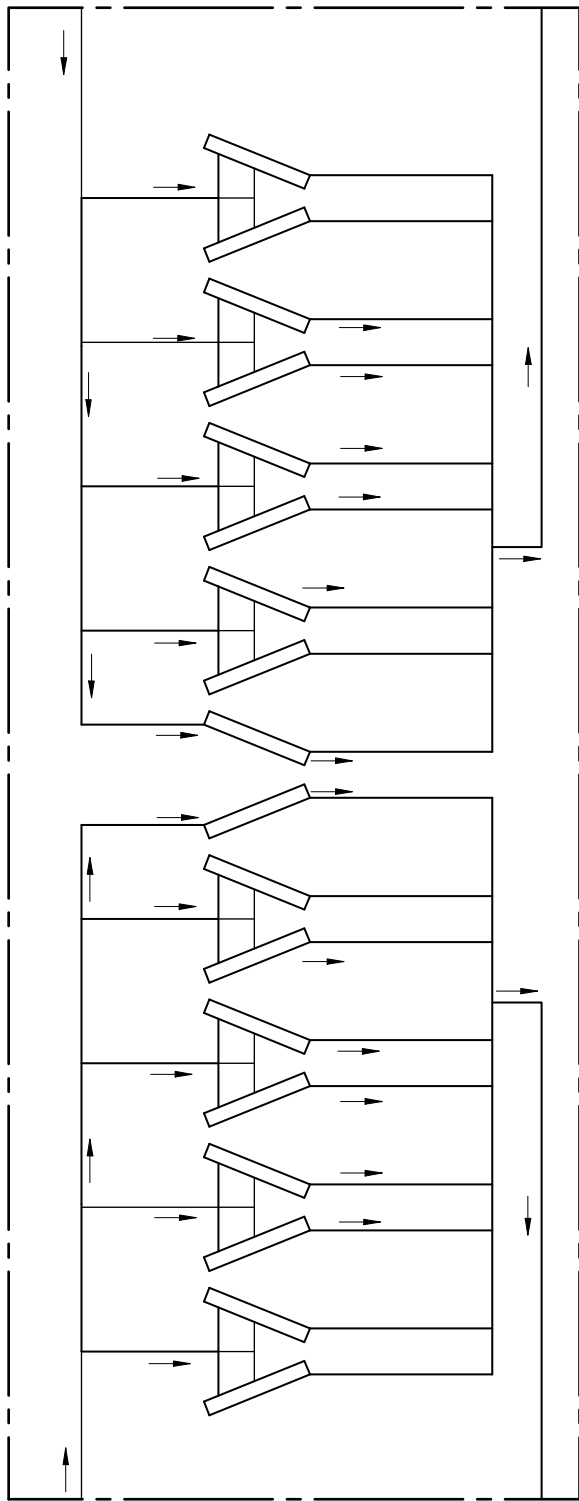

PART. "A"  
FA4/FD4\_117  
FAL/FDL\_127

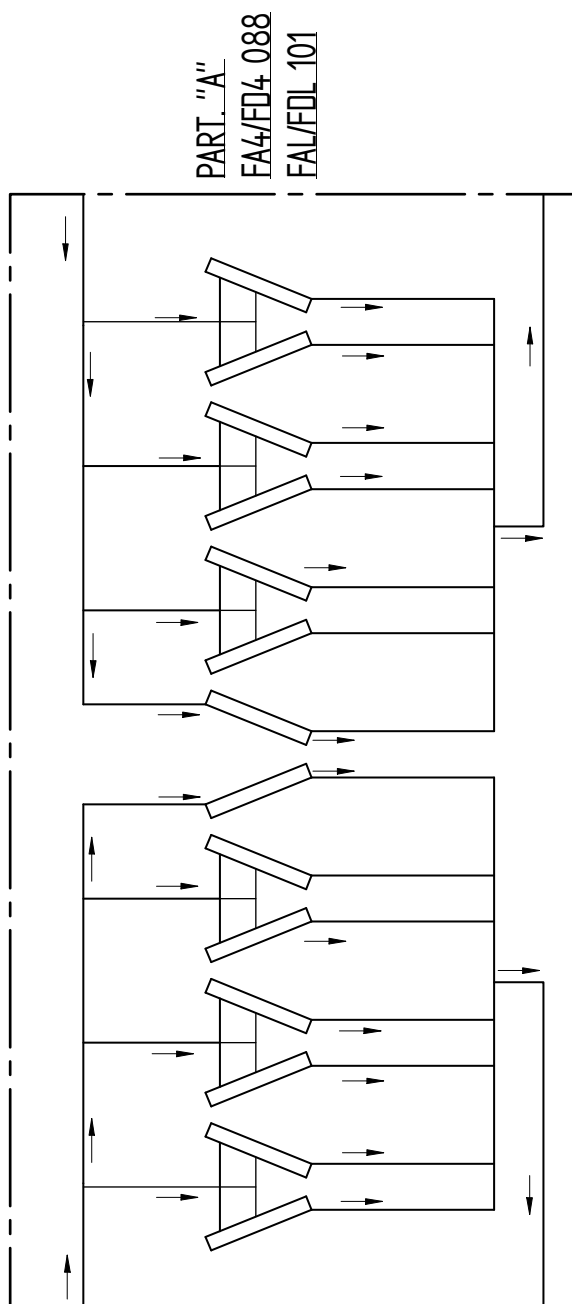

PART. "A"  
FA4/FD4\_088  
FAL/FDL\_101

Fig. 10c - FREECOOLING REFRIGERANT DIAGRAM

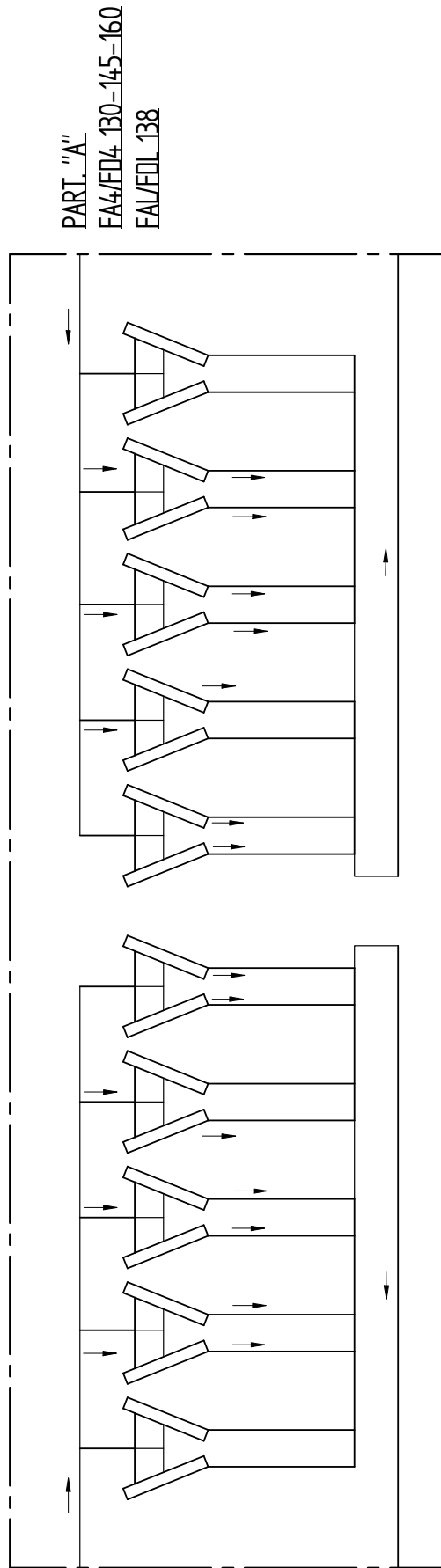
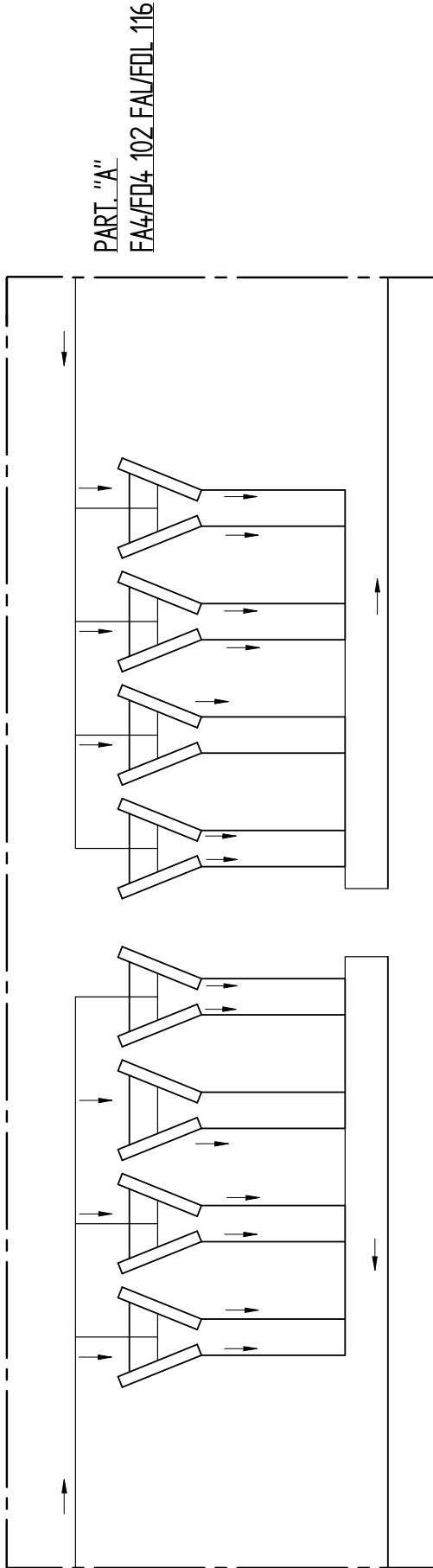
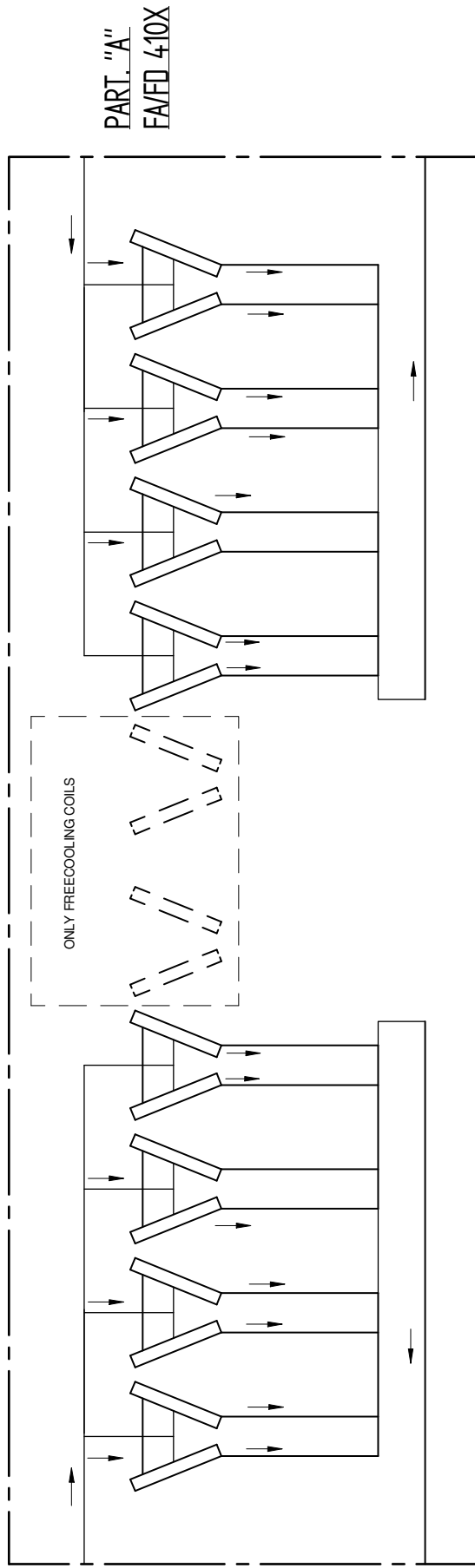
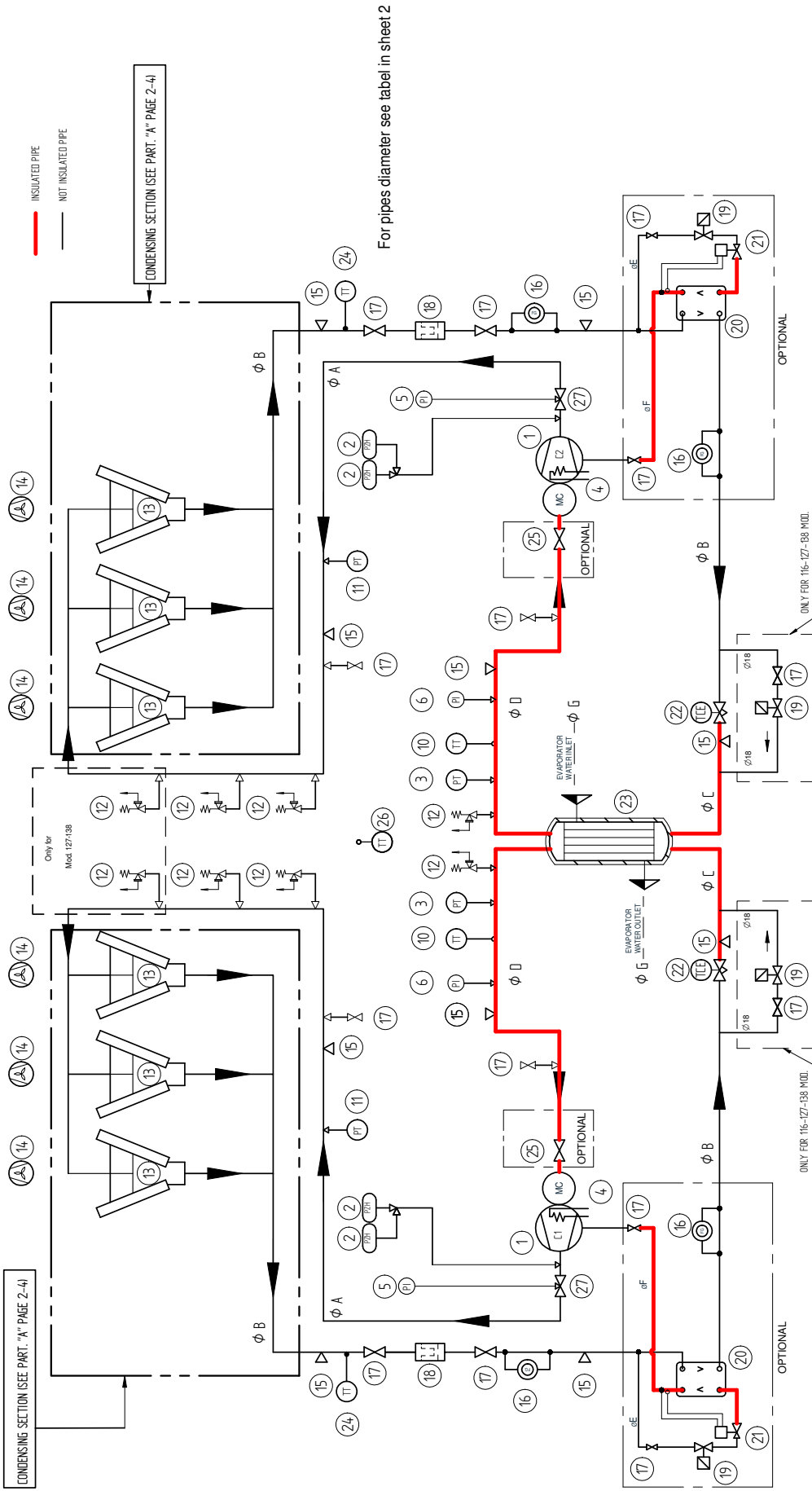

Fig. 10d - FREECOOLING REFRIGERANT DIAGRAM



**FIG 10e - CHILLER REFRIGERANT DIAGRAM**



1	2	3	4	5	6	7	8	9	10	11	12	13	14	15	16	17	18	19	20	21	22	23	24	25	26	27
COM PRESSOR	HIGH PRESSURE SWITCH	TRANSDUCER PRESSURE SENSOR LP CONTROL	CRANKCASE HEATER	HIGH PRESSURE MANOMETER	LOW PRESSURE MANOMETER	SOLENOID VALVE	NO RETURN VALVE	MOTORIZED BALL VALVE	TEMPERATURE SENSOR	TRANSDUCER PRESSURE SENSOR HP CONTROL	SAFETY VALVE	CONDENSER	CONDENSER Fans	SERVICE CONNECTION	SIGHT GLASS	SHUT-OFF VALVE	FILTER DRYER	SHUT-OFF SOLENOID VALVE	ECONOMIZER	THERMOSTATIC EXPANSION VALVE	ELECTRONIC EXPANSION VALVE	Evaporator	LIQUID TEMPERATURE SENSOR	COMPRESSOR SUCTION VALVE	EXTERNAL AIR SENSOR	COMPRESSOR DISCHARGE VALVE

FIG 10f - CHILLER REFRIGERANT DIAGRAM

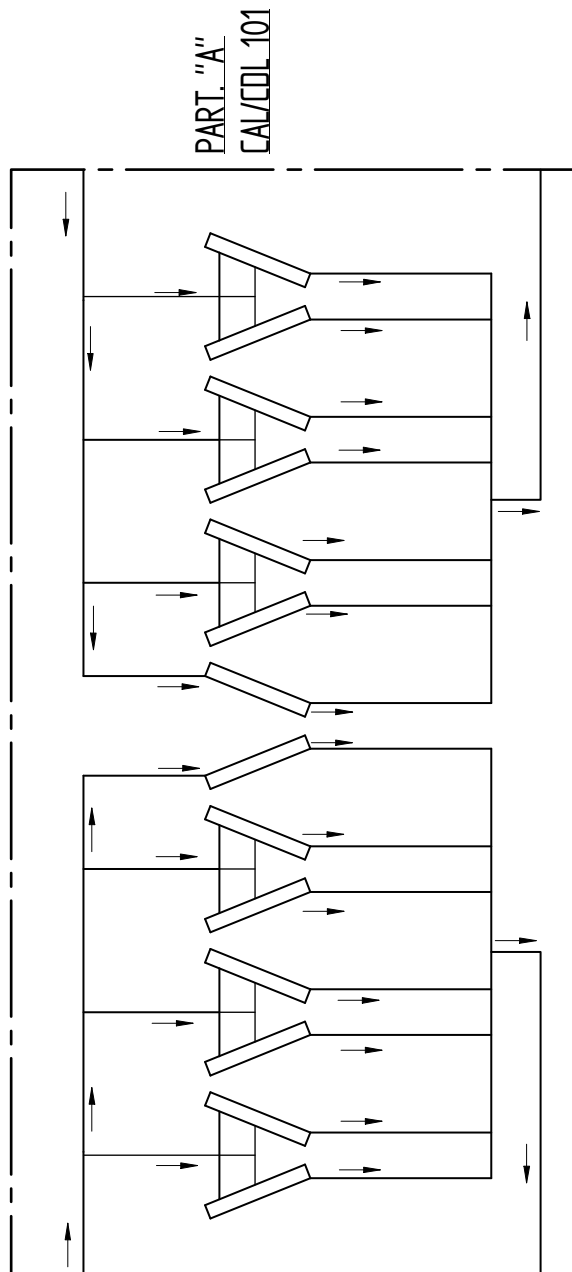
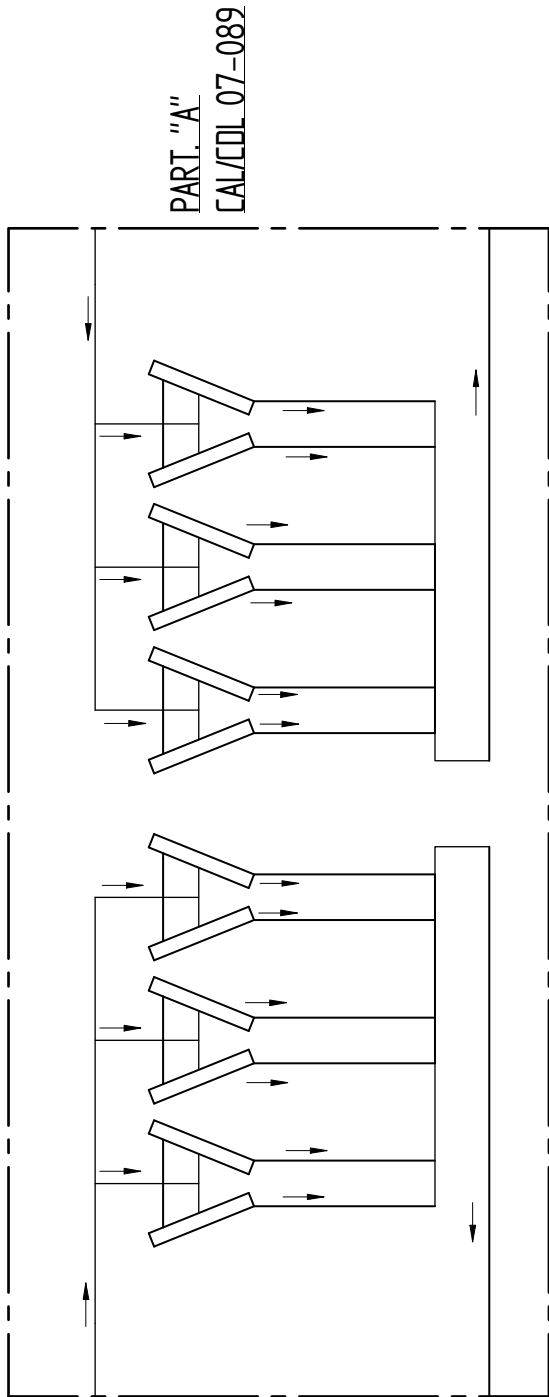

FIG 10g - CHILLER REFRIGERANT DIAGRAM

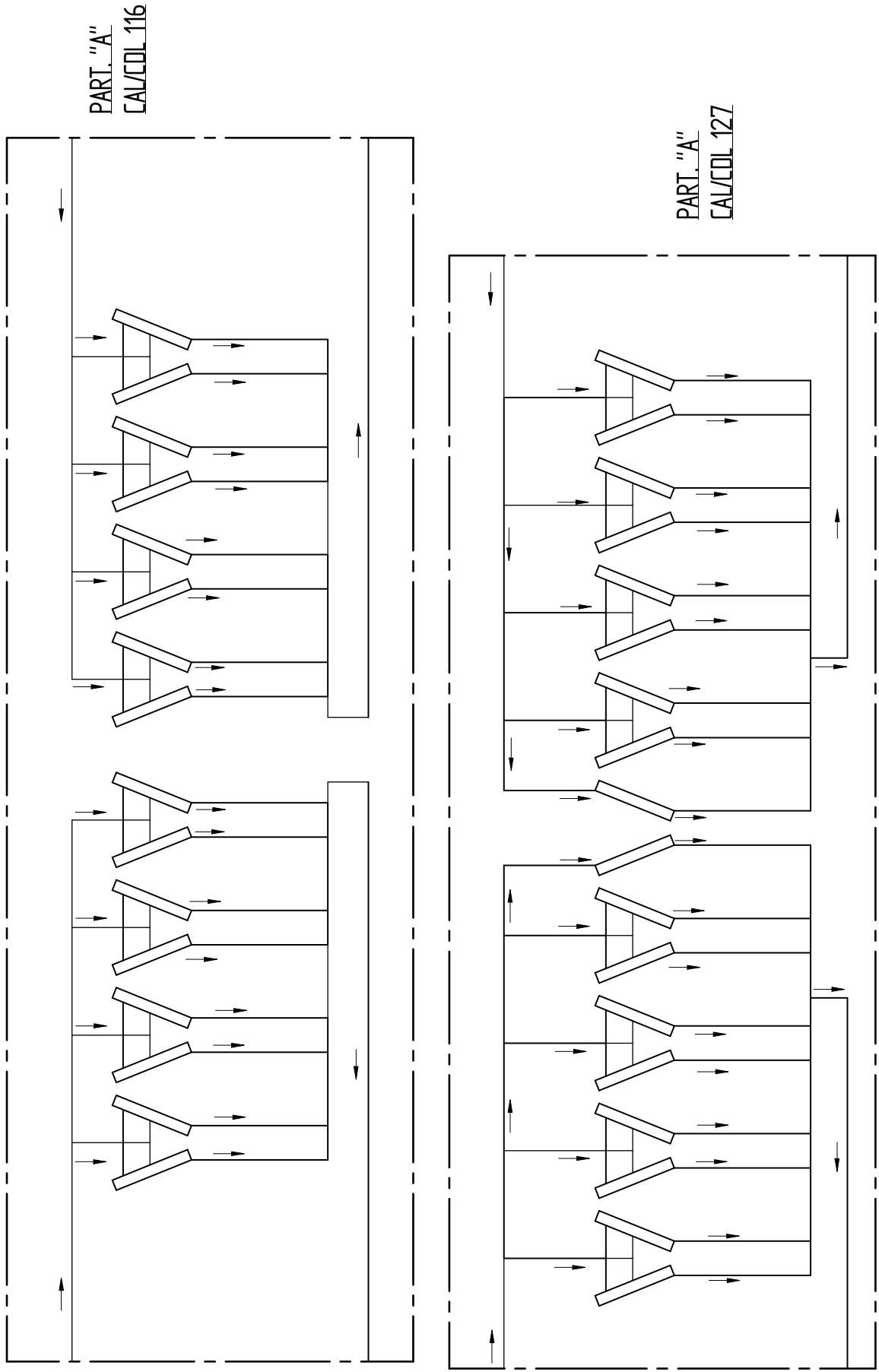
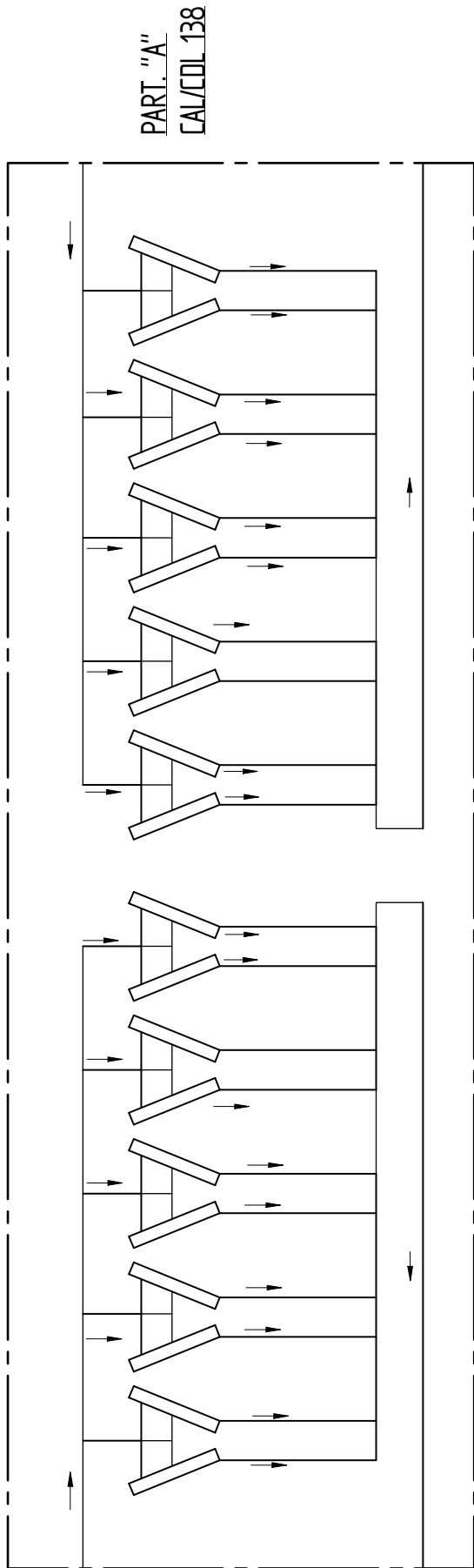
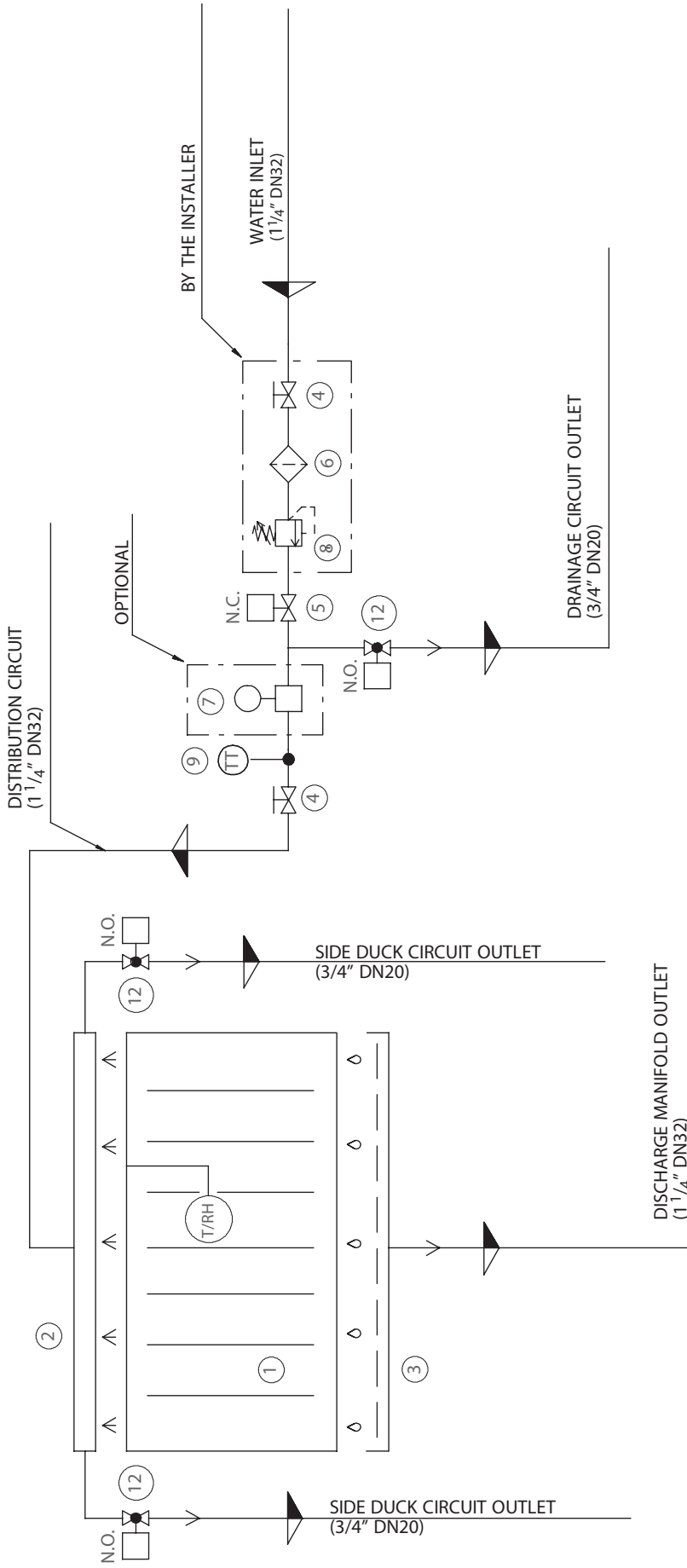

FIG 10h - CHILLER REFRIGERANT DIAGRAM



## Fig. 11 - Hydraulic circuit

Fig. 11a - SYSTEM ADIABATIC HYDRAULIC CIRCUIT WITHOUT TANK AND PUMP (12 ÷ 20 FANS)



Tab. 11.1 - Hydraulic components

Pos.	Description	Pos.	Description
1	Evaporating Pad	7	Flow meter
2	Delivery manifold	8	Pressure regulator
3	Discharge manifold	9	Pressure connection
4	Gate valve	10	-
5	Solenoid valve	11	-
6	Filter	12	Motorized ball valve

Fig. 11b - SYSTEM ADIABATIC HYDRAULIC CIRCUIT WITH BUILT-IN TANKS (12 FANS)

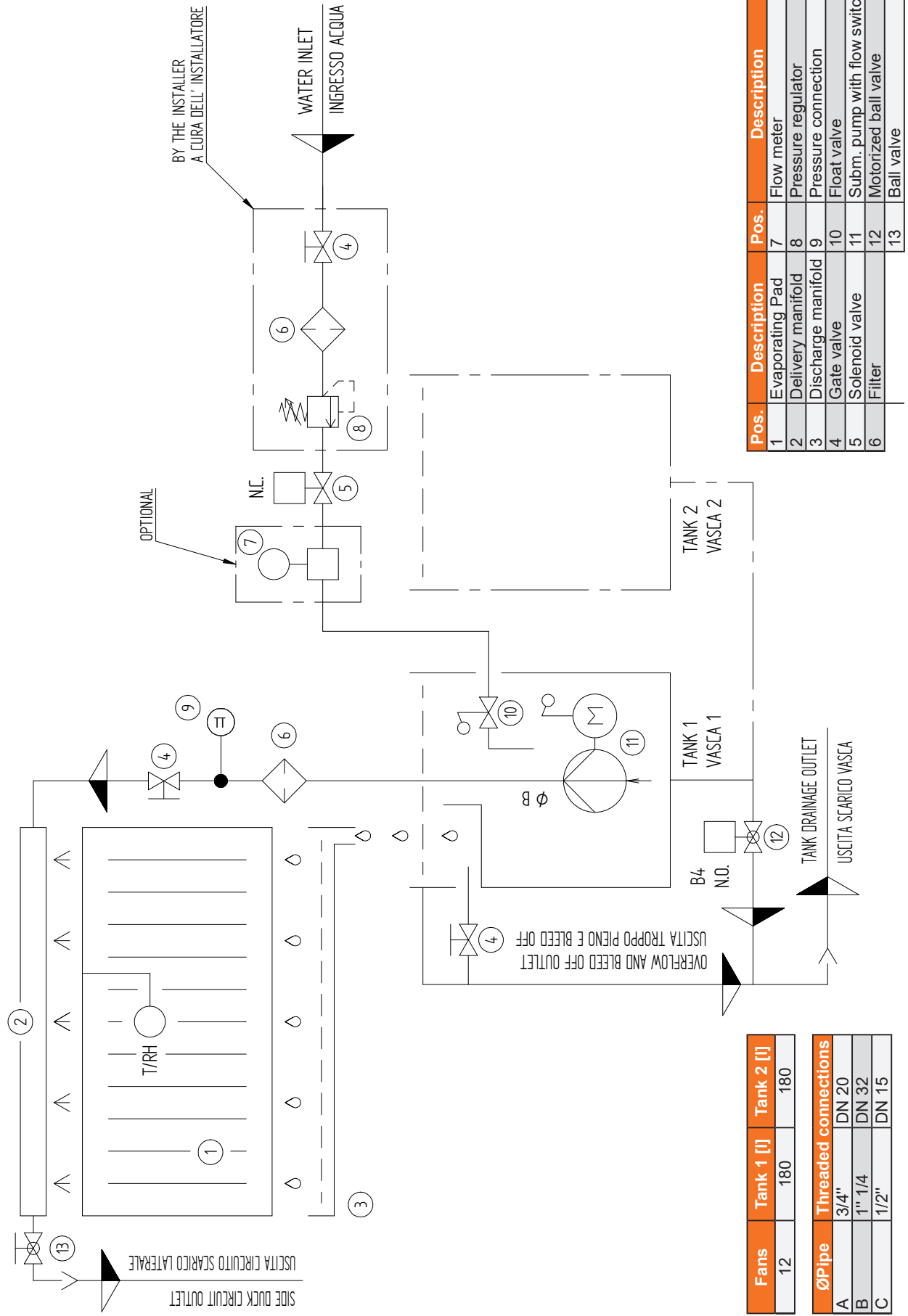
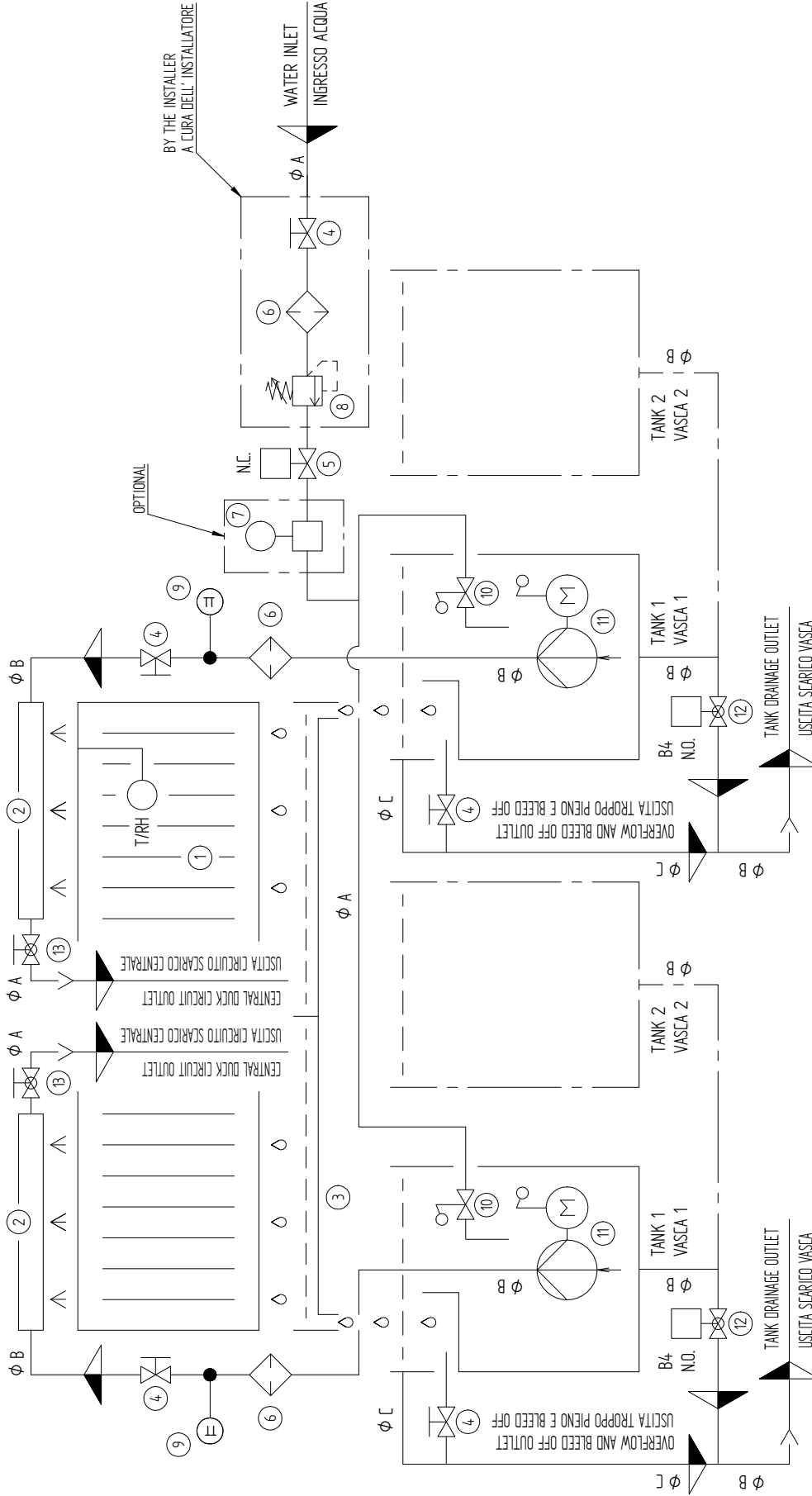

Fig. 11c - SYSTEM ADIABATIC HYDRAULIC CIRCUIT WITH BUILT-IN TANKS (14 ÷ 20 FANS)



Pos.	Description	Pos.	Description
1	Evaporating Pad	7	Flow meter
2	Delivery manifold	8	Pressure regulator
3	Discharge manifold	9	Pressure connection
4	Gate valve	10	Float valve
5	Solenoid valve	11	Subm. pump with flow switch
6	Filter	12	Motorized ball valve
		13	Ball valve

Fans	Tank 1 [l]	Tank 2 [l]
14	180	180
16	180	180
18	180	180
20	180	180

ØPipe	Threaded connections
A	3/4"
B	1" 1/4
C	1/2"

**Fig. 11d - FREECOOLING HYDRAULIC CIRCUIT**

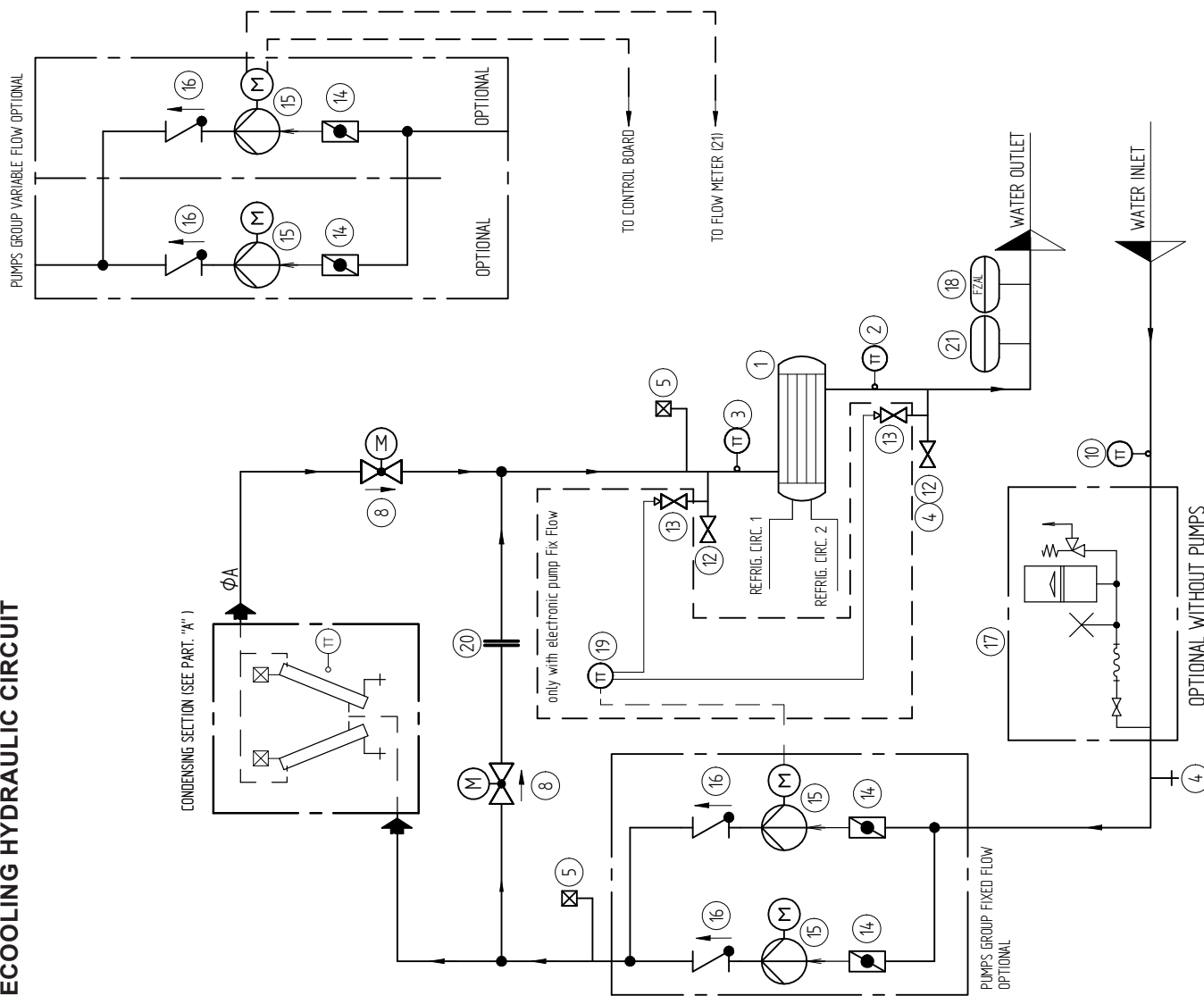

N.	DESCRIPTION
1	Evaporator
2	Evaporator WATER OUTLET SENSOR / ANTIFREEZE
3	Evaporator WATER INLET SENSOR
4	DISCHARGE VALVE
5	MANUAL AIR VALVE
6	Freecooling coil
7	
8	2 WAY VALVE
9	AIR TEMPERATURE SENSOR
10	CONTROL FREEC.
11	THERMOSTAT SENSOR
12	SERVICE VALVE WITH CAP
13	VALVE (only with electronic pump Fix Flow)
14	BUTTERFLY VALVE
15	PUMP
16	NO RETURN VALVE
17	KIT EXPANSION VASSEL - SAFETY VALVE - MANUAL AIR VALVE - FLEX. PIPE - VALVE
18	FLOW SWITCH
19	WATER DIFFERENTIAL PRESSURE TRASDUCER (only with electronic pump Fix Flow)
20	CALIBRATE BAFFLE (not present with electronic pump Fix Flow)
21	FLOW METER (OPTIONAL)

MODELS	INLET-OUTLET UNIT	
	Grooved CONNECTION	
FA/FD	4088	4" - DN100 - 114,3mm
	410X	5" - DN125 - 139,7mm
	4102	6" - DN150 - 168,3mm
	L116	
	4117	
	L127	8" - DN200 - 219,1mm
	4130	6" - DN150 - 168,3mm
	L138	
	4145	8" - DN200 - 219,1mm
	4160	

**Fig. 11e - FREECOOLING HYDRAULIC CIRCUIT**

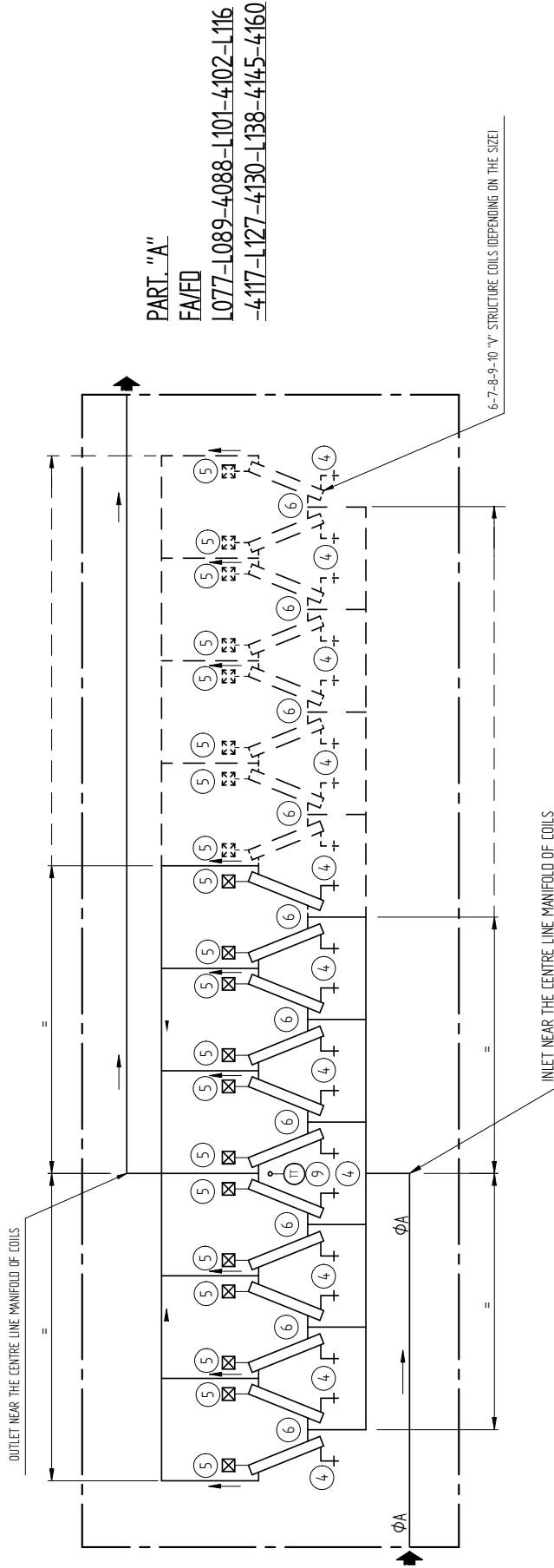

**FIG 11f - CHILLER HYDRAULIC DIAGRAM**

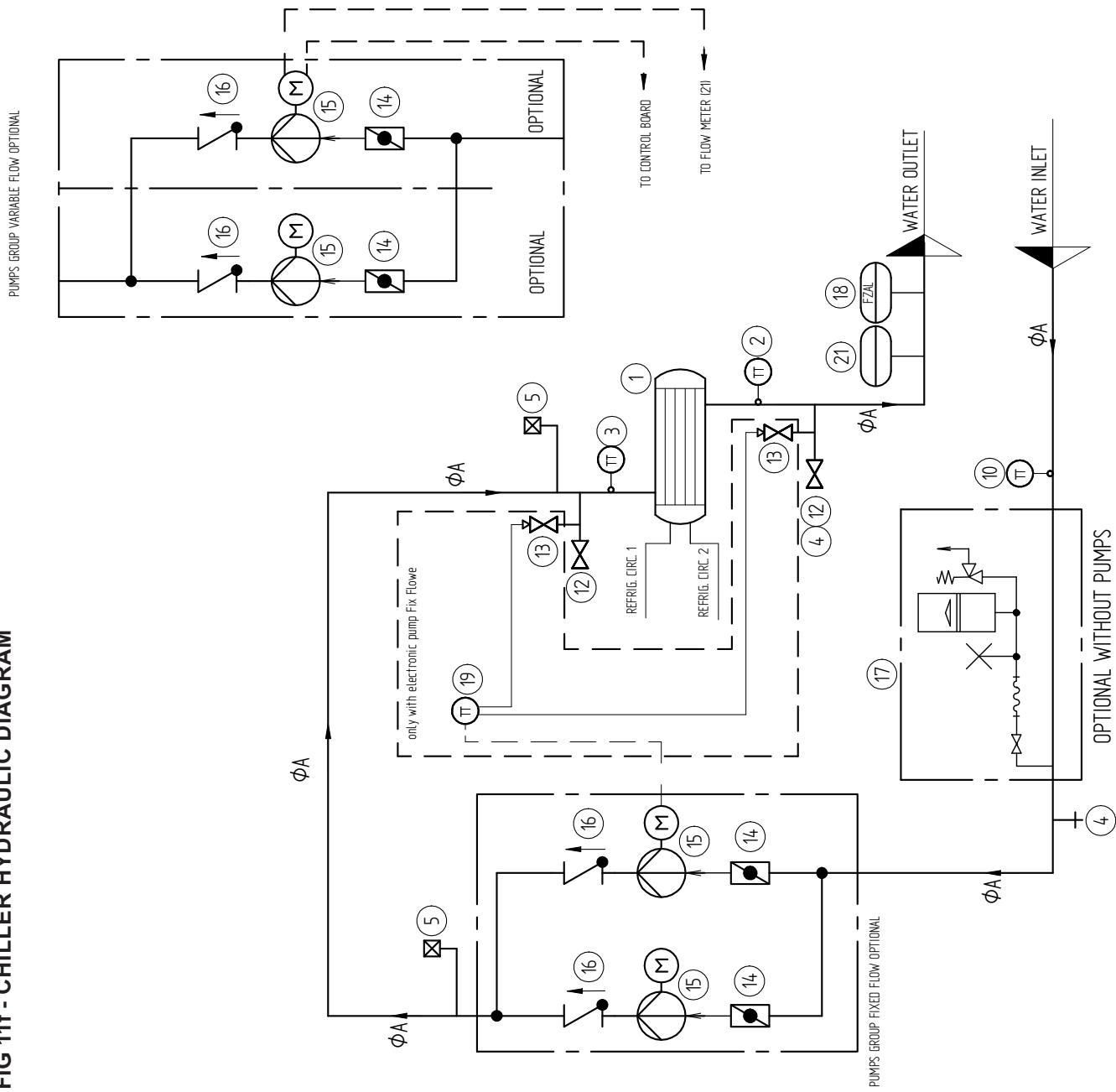

N.	DESCRIPTION
1	Evaporator
2	Evaporator WATER OUTLET SENSOR / ANTIFREEZE
3	Evaporator WATER INLET SENSOR
4	DISCHARGE VALVE
5	MANUAL AIR VALVE
6	Freecooling coil
7	
8	2 WAY VALVE
9	AIR TEMPERATURE SENSOR
10	CONTROL FREEC. THERMOSTAT SENSOR
11	
12	SERVICE VALVE WITH CAP
13	VALVE (only with electronic pump Fix Flow)
14	BUTTERFLY VALVE
15	PUMP
16	NO RETURN VALVE
17	KIT EXPANSION VASSEL - SAFETY VALVE - MANUAL AIR VALVE - FLEX. PIPE - VALVE
18	FLOW SWITCH
19	WATER DIFFERENTIAL PRESSURE TRASDUCER (only with electronic pump Fix Flow)
20	CALIBRATE BAFFLE (not present with electronic pump Fix Flow)
21	FLOW METER (OPTIONAL)

MODELS	INLET-OUTLET UNIT	
	Grooved CONNECTION	
FA/FD	4088	4" - DN100 - 114,3mm
	410X	5" - DN125 - 139,7mm
	4102	
	L116	6" - DN150 - 168,3mm
	4117	
	L127	8" - DN200 - 219,1mm
	4130	6" - DN150 - 168,3mm
	L138	
	4145	8" - DN200 - 219,1mm
	4160	



**VERTIV™**

Fabbricante - Manufacturer - Hersteller - Fabricant - Fabricante Fabricante - Tillverkare - Fabrikant - Valmistaja - Produzent Fabrikant  
- Κατασκευαστής - Producent  
Vertiv S.r.l. - Zona Industriale Tognana  
Via Leonardo da Vinci, 16/18 - 35028 Piove di Sacco - Padova (Italy)

Il Fabricante dichiara che questo prodotto è conforme alle direttive Europee:

The Manufacturer hereby declares that this product conforms to the European Union directives:

Der Hersteller erklärt hiermit, dass dieses Produkt den Anforderungen der Europäischen Richtlinien gerecht wird: Le Fabricant déclare que ce produit est conforme aux directives Européennes:

El Fabricante declara que este producto es conforme a las directivas Europeas:

O Fabricante declara que este produto está em conformidade com as directivas Europeias: Tillverkare försäkrar härmed att denna produkt överensstämmer med Europeiska Unionens direktiv: De Fabrikant verklaart dat dit produkt conform de Europese richtlijnen is:

Vaimistaja vakuuttaa täten, että tämä tuote täyttää seuraavien EU-direktiivien vaatimukset: Produzent erklærer herved at dette produktet er i samsvar med EU-direktiver:

Fabrikant erklærer herved, at dette produkt opfylder kravene i EU direktiverne:

Ο Κατασκευαστής δηλώνει ότι το παρόν προϊόν είναι Αποσχετισμένο σύμφωνα με τις οδηγίες της Ε.Ε.:

**2006/42/EC; 2014/30/EU; 2014/35/EU; 2014/68/EU; 2011/65/EU; EU/2015/863**



**VertivCo.com | Vertiv - EMEA**, via Leonardo Da Vinci 16/18, Zona Industriale Tognana, 35028 Piove di Sacco (PD) Italy, Tel: +39 049 9719 111, Fax: +39 049 5841 257  
© 2022 Vertiv Co. All rights reserved. Vertiv, the Vertiv logo and Vertiv Liebert AFC are trademarks or registered trademarks of Vertiv Co. All other names and logos referred to are trade names, trademarks or registered trademarks of their respective owners. While every precaution has been taken to ensure accuracy and completeness herein, Vertiv Co. assumes no responsibility, and disclaims all liability, for damages resulting from use of this information or for any errors or omissions. Specifications are subject to change without notice.

Liebert® AFC - UM - 265483MAN\_ENG - 22.08.2022