



# **Liebert® MC**

## **Air Cooled Remote Condenser with Microchannel Coil**

User Manual

English, 10019237MAN\_ENG, rev. C - 31.03.2022



# Contents

|                                          |          |                                                       |           |
|------------------------------------------|----------|-------------------------------------------------------|-----------|
| <b>1. Safety</b> .....                   | <b>1</b> | <b>8. Installation</b> .....                          | <b>12</b> |
| 1.1 Conventions.....                     | 1        | 8.1 Overview.....                                     | 12        |
| 1.2 General Instructions.....            | 1        | 8.2 Safety Instructions.....                          | 12        |
| 1.3 Electric System.....                 | 1        | 8.3 Location.....                                     | 12        |
| 1.4 Automatic Restart.....               | 2        | 8.4 Space Requirements.....                           | 13        |
| 1.5 Personal Protective Equipment.....   | 2        | 8.5 Piping.....                                       | 14        |
| <b>2. Digit Nomenclature</b> .....       | <b>3</b> | 8.6 Electrical Connections.....                       | 15        |
| <b>3. Intended Use</b> .....             | <b>4</b> | <b>9. Unit Controller</b> .....                       | <b>18</b> |
| 3.1 Functional Limits.....               | 4        | 9.1 Controlled by Indoor Unit.....                    | 18        |
| 3.2 Operating environment.....           | 4        | <b>10. Maintenance</b> .....                          | <b>19</b> |
| 3.3 Space Limits.....                    | 4        | 10.1 Safety Instructions.....                         | 19        |
| <b>4. Test and Reference Norms</b> ..... | <b>5</b> | 10.2 Safety Labels.....                               | 20        |
| <b>5. Description</b> .....              | <b>6</b> | 10.3 Refrigeration System.....                        | 20        |
| 5.1 Main Components.....                 | 6        | 10.4 Heat Exchanger.....                              | 20        |
| 5.2 Electric System.....                 | 6        | 10.5 Fans.....                                        | 21        |
| 5.3 Mechanical Specifications.....       | 7        | <b>11. Troubleshooting</b> .....                      | <b>22</b> |
| 5.4 Efficiency Control System.....       | 7        | <b>12. Dismantling the unit</b> .....                 | <b>23</b> |
| <b>6. Technical Data</b> .....           | <b>8</b> | 12.1 Safety Instructions.....                         | 23        |
| 6.1 Technical Data and Performances..... | 8        | 12.2 Operations.....                                  | 24        |
| 6.2 Coil Dimensions.....                 | 8        | <b>13. Regulation (EU) no. 517/2014 (F-gas)</b> ..... | <b>25</b> |
| 6.3 Installation Dimensions.....         | 8        | 13.1 Introduction.....                                | 25        |
| <b>7. Handling</b> .....                 | <b>9</b> | 13.2 Normative References.....                        | 25        |
| 7.1 Safety Instructions.....             | 9        | 13.3 Fluorinated Greenhouse Gases.....                | 25        |
| 7.2 Inspection.....                      | 9        | 13.4 Operators.....                                   | 26        |
| 7.3 Storage.....                         | 9        | 13.5 Leakage Detection.....                           | 26        |
| 7.4 Transport - with Package.....        | 10       | 13.6 Labelling.....                                   | 27        |
| 7.5 Unpacking.....                       | 10       | 13.7 Record Keeping.....                              | 27        |
| 7.6 Transport - without Package.....     | 11       |                                                       |           |

# Annexes

|                                              |              |
|----------------------------------------------|--------------|
| <b>Annex I – Dimensions and Weight</b> ..... | <b>I-28</b>  |
| <b>Annex II – Safety Labels</b> .....        | <b>II-32</b> |

# Documents supplied with the machine

- User Manual (this document)
- Electrical Diagrams
- Instruction Leaflet for Transport and Handling (on the packaging)
- Labels with Gravity Center (on the packaging)
- Warranty Certificate
- Test Certificate
- Declaration of Conformity

# Onboard Label



Please refer to the label placed on the unit for the relevant operating data.

If you need assistance or spare parts, please find the model identification and the serial number on the label.



### NOTICE

The data in the manual are referred to standard conditions and can be modified without any advance notice.  
The data relevant to the supplied unit are filled in the inboard label (see below an empty facsimile).

|                                                                                                                                                                                                                                                                                                                    |                    |             |                    |
|--------------------------------------------------------------------------------------------------------------------------------------------------------------------------------------------------------------------------------------------------------------------------------------------------------------------|--------------------|-------------|--------------------|
| <br><b>VERTIV™</b> <span style="float: right;">①</span><br><br> |                    |             |                    |
| MODEL                                                                                                                                                                                                                                                                                                              | ②                  |             |                    |
| SERIAL N.                                                                                                                                                                                                                                                                                                          | ③                  |             |                    |
| VOLTAGE-PHASE-FREQUENCY                                                                                                                                                                                                                                                                                            | ④                  |             |                    |
| COMPRESSOR                                                                                                                                                                                                                                                                                                         |                    |             |                    |
| FLA                                                                                                                                                                                                                                                                                                                | LRA                |             | QT.                |
| COMPRESSOR                                                                                                                                                                                                                                                                                                         |                    |             |                    |
| FLA                                                                                                                                                                                                                                                                                                                | LRA                |             | QT.                |
| FAN MOTOR                                                                                                                                                                                                                                                                                                          |                    |             |                    |
| FLA                                                                                                                                                                                                                                                                                                                | LRA                | ⑥           | QT. ⑦              |
| FAN MOTOR                                                                                                                                                                                                                                                                                                          |                    |             |                    |
| FLA                                                                                                                                                                                                                                                                                                                | LRA                |             | QT.                |
| EL. HEATER                                                                                                                                                                                                                                                                                                         |                    |             |                    |
| A                                                                                                                                                                                                                                                                                                                  | STAGES             |             |                    |
| HUMIDIFIER                                                                                                                                                                                                                                                                                                         |                    |             |                    |
| A                                                                                                                                                                                                                                                                                                                  | STEAM OUTPUT       |             | kg/h               |
| TOTAL FLA AC                                                                                                                                                                                                                                                                                                       | TOTAL FLA DC       | Ipk         | KA                 |
| A                                                                                                                                                                                                                                                                                                                  | A                  | ICw         | KA                 |
| ⑧                                                                                                                                                                                                                                                                                                                  |                    |             | ⑨                  |
| REFRIGERANT TYPE                                                                                                                                                                                                                                                                                                   |                    |             |                    |
| CIRCUIT 1                                                                                                                                                                                                                                                                                                          | REFRIGERANT CHARGE | CIRCUIT 2   | REFRIGERANT CHARGE |
| ON FACTORY                                                                                                                                                                                                                                                                                                         | ON SITE            | ON FACTORY  | ON SITE            |
|                                                                                                                                                                                                                                                                                                                    | kg                 |             | kg                 |
|                                                                                                                                                                                                                                                                                                                    | ..... kg           |             | ..... kg           |
| MAX ALLOWABLE PRESSURE                                                                                                                                                                                                                                                                                             |                    |             |                    |
| HP SIDE(PS)                                                                                                                                                                                                                                                                                                        | bar                | LP SIDE(PS) | bar                |
| HIGH PRESS. SWITCH-MANUAL                                                                                                                                                                                                                                                                                          |                    |             |                    |
| SET                                                                                                                                                                                                                                                                                                                | bar                | RESET       | bar                |
| LOW PRESSURE SWITCH                                                                                                                                                                                                                                                                                                |                    |             |                    |
| SET                                                                                                                                                                                                                                                                                                                | bar                | RESET       | bar                |
| OPERATING AIR TEMPERATURE                                                                                                                                                                                                                                                                                          |                    |             |                    |
| min                                                                                                                                                                                                                                                                                                                | ⑩ °C               | max         | ⑪ °C               |
| OPERATING AIR HUMIDITY                                                                                                                                                                                                                                                                                             |                    |             |                    |
| min                                                                                                                                                                                                                                                                                                                | ⑫ %                | max         | ⑬ %                |
| CIRCUIT MAX. PRESSURE                                                                                                                                                                                                                                                                                              |                    |             |                    |
| bar                                                                                                                                                                                                                                                                                                                | ⑭                  |             |                    |
| NET WEIGHT                                                                                                                                                                                                                                                                                                         |                    |             |                    |
| kg                                                                                                                                                                                                                                                                                                                 | ⑮                  |             |                    |
| MANUFACTURING DATE                                                                                                                                                                                                                                                                                                 | ⑯                  |             |                    |

| Pos. | Description                                 |
|------|---------------------------------------------|
| 01   | Manufacturing plant                         |
| 02   | Model                                       |
| 03   | Serial number                               |
| 04   | Voltage/Phase/Frequency                     |
| 05   | Condenser Fan Motor Full Load Ampere [A]    |
| 06   | Condenser Fan Motor Locked Rotor Ampere [A] |
| 07   | Condenser Fan Motor Quantity                |
| 08   | Unit Total Full Load Ampere AC [A]          |
| 09   | Rated Short-Time Current [kA]               |
| 10   | Min. Ambient Operation Temperature [°C]     |
| 11   | Max. Ambient Operation Temperature [°C]     |
| 12   | Min. Ambient Operation Humidity [%]         |
| 13   | Max. Ambient Operation Humidity [%]         |
| 14   | Max . Refrigerant Circuit Pressure [bar]    |
| 15   | Unit Net Weight [kg]                        |
| 16   | Manufacturing Date                          |

# 1. Safety

This chapter gives general safety instructions.

Additional safety warnings, for specific operations, are given in the rest of the manual.

## 1.1 Conventions



**DANGER** - Indicates a hazardous situation which, if not avoided, **will** result in death or serious injury.  
**WARNING** - Indicates a hazardous situation which, if not avoided, **could** result in death or serious injury.  
**CAUTION** - Indicates a hazardous situation which, if not avoided, **may** result in minor or moderate injury.



**NOTICE**  
 Indicates a property damage message

## 1.2 General Instructions

|                               |                                                                                                                                                                                    |
|-------------------------------|------------------------------------------------------------------------------------------------------------------------------------------------------------------------------------|
| <b>Intended readers</b>       | This User Manual is intended for transport, installation and maintenance personnel.<br>The end user can only switch the unit <b>ON</b> and <b>OFF</b>                              |
| <b>Authorized personnel</b>   | The operations described in this manual must be made by technical staff, expressly authorized in compliance with the regulations in force at the installation site.                |
| <b>Read this manual</b>       | Carefully read the manual before performing any operation on the unit.                                                                                                             |
| <b>Keep this manual</b>       | Keep the manual during the complete life-span of the unit.<br>If you move or sell the unit, transfer the manual together with the unit.                                            |
| <b>Intended use</b>           | Exclusively employ the unit for the purpose it has been designed (see 3. <i>Intended Use</i> ).<br>The improper use of the unit exonerates the manufacturer of any responsibility. |
| <b>Do not modify the unit</b> | Do not modify the unit in any way, including the control system and the software.<br>Any modification to the unit exonerates the manufacturer of any responsibility.               |
| <b>Warning labels</b>         | Pay attention to the warning labels on the unit.<br>See <i>Annex III – Safety Labels</i> for the mapping of the safety labels placed on the unit.                                  |

## 1.3 Electric System



### WARNING

Unit contains potentially lethal voltage in some circuits.  
 Risk of arc flash and electric shock.  
 Can cause injury or death.

- Open all local and remote unit electric power disconnect switches, verify with a voltmeter that power is **OFF** and wear protective equipment per local standard before working within the electric control enclosure.



### WARNING

The electric connection enclosures, the fan speed control and the EC fan enclosures can retain a stored high-voltage electrical charge for up to **10** minutes.

Risk of electric shock.  
 Can cause serious injury or death.

Before working within the unit electric connection enclosures or working within the fan speed control and the EC fan enclosures proceed as follows:

- open all local and remote unit electric power disconnect switches
- wait **10** minutes
- verify with a voltmeter that power is **OFF**

Only properly trained and qualified personnel may perform repair, maintenance and cleaning.

## 1.4 Automatic Restart



### WARNING

Fan blades can automatically start rotating without warning at any time during a cooling cycle or after power is restored after a power failure.

Risk of contact with high-speed, rotating fan blades.

Can cause serious personal injury or death.

Before working within the unit cabinet, removing the fan guards or servicing the fan speed control, fan blades or EC fan motors proceed as follows:

- open all local and remote electric power supply disconnect switches
- wait **10** minutes
- verify with a voltmeter that power is **OFF**



### WARNING

This unit operates and restarts automatically.

The fans may suddenly start blowing out a strong air flow, which may carry particles and small objects from inside the unit.

Can cause serious personal injury.

- Wear eyes protection when you need to get close to the unit while it is operating.
- Turn the main switch to **OFF** to disconnect the unit from the power supply before any operation on the unit.

## 1.5 Personal Protective Equipment

As a general rule, always wear the following **PPE** (Personal Protective Equipment):



### CAUTION

The microchannel condenser is made of plates and fins, which may have sharp edges and blurs. Always wear cut resistant gloves when operating on the condenser.



### CAUTION

Components at high temperature (condenser inlet piping at about 120°C).

Always wear temperature resistant gloves when operating on the condenser.

## 2. Digit Nomenclature

The unit is fully defined by twenty five digits.

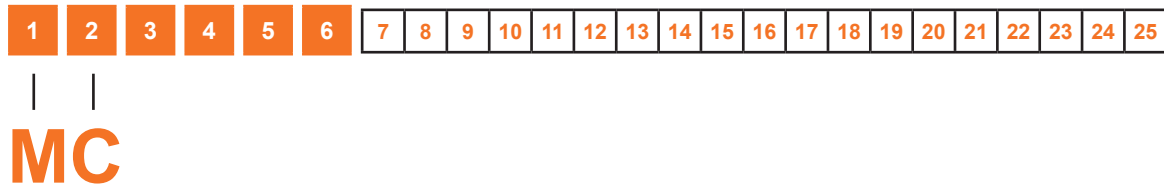

| Digit                      | Feature                       | Value                | Description                                       |
|----------------------------|-------------------------------|----------------------|---------------------------------------------------|
| <b>1</b> <b>2</b>          | Unit Family:                  | <b>MC</b>            | Micro Channel                                     |
| <b>3</b>                   | Platform Size:                | <b>M</b><br><b>L</b> | Medium<br>Large                                   |
| <b>4</b> <b>5</b> <b>6</b> | Heat Rejection Capacity "kW": |                      |                                                   |
| <b>7</b>                   | Control Fan Type:             | <b>M</b>             | Controlled by Indoor Unit                         |
| <b>8</b>                   | Refrigerant Circuit:          | <b>P</b>             | Single Circuit Econo-phase                        |
| <b>9</b>                   | Power Supply:                 | <b>M</b><br><b>K</b> | 400V / 3ph / 50Hz<br>380 - 480V / 3ph / 50 - 60Hz |
| <b>10</b>                  | Packaging                     | <b>P</b>             | Econophase packaging                              |
| <b>11</b>                  | Coil Coating                  | <b>0</b><br><b>E</b> | None<br>E-coat (Epoxy)                            |
| <b>12</b>                  | Panel Material                | <b>A</b>             | Bright Aluminium                                  |
| <b>13</b>                  | Connection Pipe               | <b>M</b>             | Metric                                            |
| <b>14</b>                  | Legs Included                 | <b>X</b>             | Legs for horizontal and vertical flow             |
| <b>15</b>                  | Agency Certification          | <b>E</b>             | CE agency certification                           |
| <b>16</b>                  | Sound Level                   | <b>0</b>             | Standard Sound                                    |
| <b>17</b>                  | Low temperature configuration | <b>0</b>             | None                                              |
| <b>18</b>                  | Fusible Plug Kit              | <b>0</b><br><b>1</b> | None<br>Change Over Safety Valves                 |
| <b>19</b>                  | Sensors and Probe             | <b>3</b>             | Air and refrigerant temperature sensor            |
| <b>20 - 21</b>             | Free                          |                      |                                                   |
| <b>22</b>                  | Special Feature               | <b>A</b><br><b>X</b> | No SFA<br>With SFA                                |
| <b>23 - 25</b>             | Free                          |                      |                                                   |

## 3. Intended Use

The **Liebert® MC** microchannel heat exchanger is a range of remote air-cooled condensers designed to be coupled with **Liebert®** air conditioning units.

The **Liebert® MC** condensers are equipped either with EC axial fans.

The single system has a set of discharge/liquid pipe to match the single refrigeration system of indoor unit.

### 3.1 Functional Limits

**Refrigerant** This unit is designed for use with R410 A (group 2, not dangerous according to PED Directive).



**WARNING**

Risk of components failure or breakage.  
Do not use other refrigerants.  
Contact the manufacturer in case of doubt.

**Performance** Nominal heat rejection capacity: See *6.0 Technical Data*  
MAX working pressure: 45 barg

**Electrical system requirements** Voltage and Frequency Limits:  
**MC** with EC Fan 3Ph  
380V-480V ± 10%  
50-60Hz 0,99 to 1,01 of nominal frequency continuously  
0,98 to 1,02 short time  
**Protection level:** Electrical control box: IP55, Unit body: IPX5



**WARNING**

Risk of components failure or breakage.  
Do not use different voltage.  
Contact the manufacturer in case of doubt.

### 3.2 Operating environment

This unit is designed for outdoor installation, with the following ambient conditions:

**Outdoor ambient temperature** -30 °C – +48 °C with “Controlled by Indoor Unit”

**Outdoor ambient humidity** 5% – 95%

**Ambient** Do not use in explosive, acid or anyway aggressive atmosphere.  
In case of installation near the sea or other particularly atmosphere conditions consider to order the Epoxy coating.

**Altitude** ≤1000 m  
Derating is required if the altitude exceeds 1000 m

### 3.3 Space Limits

**Overall unit dimensions** Provide enough free space to place the unit. See *Annex II – Dimensions and Weight*

Keep a free space around the unit as explained in *8.4 Space Requirements*.

**Clearance**



**NOTICE**

The unit does not operate correctly if placed too close to walls or other obstacles.

## 4. Test and Reference Norms

Liebert® MC units are designed, manufactured and tested according to the following directives and standards:

|                                              |                                                                                                                                                                                                                                                                                                                                                                 |
|----------------------------------------------|-----------------------------------------------------------------------------------------------------------------------------------------------------------------------------------------------------------------------------------------------------------------------------------------------------------------------------------------------------------------|
| <b>EU Directives</b>                         | <ul style="list-style-type: none"> <li>- Machine Directive 2006/42/CE</li> <li>- PED 2014/68/EU</li> <li>- LVD 2014/35/EU</li> <li>- EMC 2014/30/EU</li> <li>- RoHS II Directive 2011/65/EU</li> <li>- RoHS III Directive EU/2015/863</li> </ul>                                                                                                                |
| <b>Electrical Board</b>                      | <ul style="list-style-type: none"> <li>- EN 60204-1</li> <li>- CEI 20-22 II</li> <li>- IEC 332-3 cat. A.</li> </ul>                                                                                                                                                                                                                                             |
| <b>Electro-Magnetic Compability (EMC)</b>    | <ul style="list-style-type: none"> <li>- EN 61000-6-2:2005 Electromagnetic compatibility (EMC) - Part 6-2: Generic standards - Immunity for industrial environments</li> <li>- EN 61000-6-3:2011 Electromagnetic compatibility (EMC) - Part 6-3: Generic standards - Emission standard for residential, commercial and light-industrial environments</li> </ul> |
| <b>Performances</b>                          | <ul style="list-style-type: none"> <li>- Heat rejection capacities tests (with R410A): UNI EN 327</li> <li>- Sound pressure levels (referred to 5m far from the unit): EN13487</li> </ul>                                                                                                                                                                       |
| <b>CE Marking and Conformity Declaration</b> | <p>The units are marked “CE”.</p> <p>Each unit is supplied complete with individual test certificate and a certificate of conformity to the European Union Directives.</p> <p>See also the last page.</p>                                                                                                                                                       |

## 5. Description

### 5.1 Main Components

View from electric box side (front side)

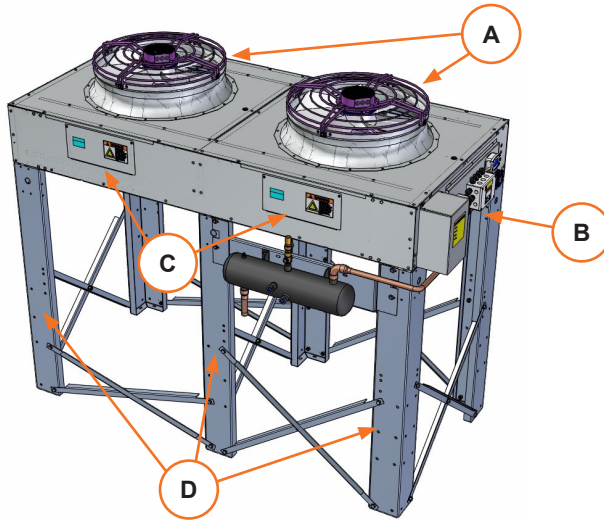

- |   |                                     |
|---|-------------------------------------|
| A | Fans                                |
| B | Electric box                        |
| C | Windows for inspection and cleaning |
| D | Supporting structure                |

### 5.2 Electric System

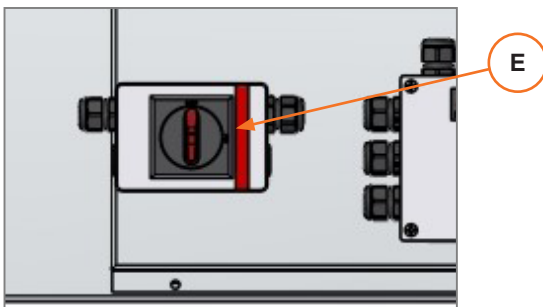

The figure shows the electric box.

The main switch [E] is a disconnecting switch and cuts off the electric power supply to the unit.

The controller, connected to the main unit, starts / stops the unit operation.

### 5.3 Mechanical Specifications

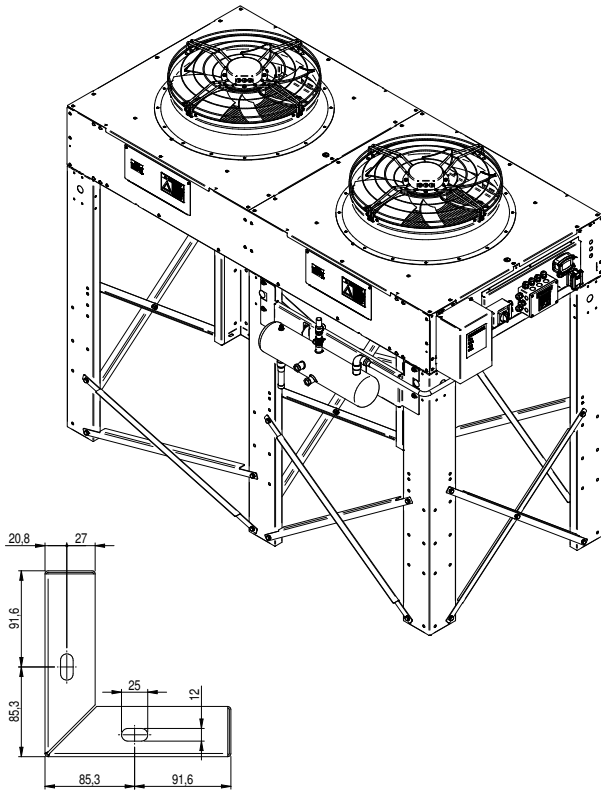

The cabinet and legs are made of aluminum. In the multi-fan models the air flow is maintained separated. The protection mask of copper pipe is used to protect the inlet and outlet copper pipes.

The window is used to clear the heat exchanger periodically. The attaching legs are the same for horizontal and vertical installation.

#### Fan

The axial fan motor is built with external rotor.

The position and appearance of the fan are shown in the figures of this page.

#### Temperature sensor

One is installed at the outlet of the condenser inside the protection mask of copper pipe. The other is installed on the end plate under the electrical control box. They are used to collect the outlet temperature of the condenser and ambient temperature respectively.

### 5.4 Efficiency Control System

#### EC fans

The EC fan is an integral assembly of an electronically commutated motor, quiet fan blade assembly and finger/hail guard.

#### Control by Indoor Unit/EC Fan

The condenser is directly connected to the indoor unit via Modbus communication. The unit is able to optimize the system by managing everything through a single control, then combines the advantages of EC fans with system management. The system allows to adjust the system pressure (head pressure setpoint). The pressure transducer is present and wired inside the indoor unit.

## 6. Technical Data and Performance

### 6.1 Technical Data and Performances

| Model  |                           | Power supply | Total Heat Rejection<br>* R410A | Air Volume | Noise Level<br>** | Power Input | Current Absorption | FLA  |
|--------|---------------------------|--------------|---------------------------------|------------|-------------------|-------------|--------------------|------|
|        |                           | [V/Ph/Hz]    | [kW]                            | [m3/h]     | [dB(A)]<br>@5m    | [kW]        | [A]                | [A]  |
| MCM080 | Controlled by Indoor Unit | 400/3/50     | 86,2                            | 23700      | 59                | 1,45        | 2,39               | 2,7  |
| MCL055 |                           | 400/3/50     | 65,9                            | 18860      | 61,1              | 1,78        | 2,75               | 3,5  |
| MCL110 |                           | 400/3/50     | 131,9                           | 37720      | 64,1              | 3,53        | 5,45               | 7,0  |
| MCL165 |                           | 400/3/50     | 197,7                           | 56580      | 65,9              | 5,31        | 8,37               | 10,5 |
| MCM080 | Controlled by Indoor Unit | 380/3/60     | 86,2                            | 23700      | 59                | 1,48        | 2,46               | 2,8  |
| MCL055 |                           | 380/3/60     | 65,9                            | 18860      | 61,1              | 1,77        | 2,86               | 3,5  |
| MCL110 |                           | 380/3/60     | 131,9                           | 37720      | 64,1              | 3,53        | 5,72               | 7,0  |
| MCL165 |                           | 380/3/60     | 197,7                           | 56580      | 65,9              | 5,31        | 9,75               | 10,5 |
| MCM080 | Controlled by Indoor Unit | 460/3/60     | 86,2                            | 23700      | 59                | 1,48        | 2,46               | 2,8  |
| MCL055 |                           | 460/3/60     | 65,9                            | 18860      | 61,1              | 1,77        | 2,73               | 2,8  |
| MCL110 |                           | 460/3/60     | 131,9                           | 37720      | 64,1              | 3,53        | 4,74               | 5,6  |
| MCL165 |                           | 460/3/60     | 197,7                           | 56580      | 65,9              | 5,31        | 7,95               | 8,4  |

Total Heat Rejection\* @ R410A; Delta (Tsaturated condensing - Tair inlet)=15K; Toile air inlet = 35°C; Liquid subcooling = 3K; Installation height = 0m above the sea level; clean exchange surfaces  
Noise Level \*\* Sound Pressure Level measured with horizontal installation in the same operative conditions, referred to 5 m far from the unit, in a free field over a reflecting plane (according to EN13847).

### 6.2 Volumes and weights

| Platform | Model  | Fan | Circuits | Coil Volume        | Liquid receiver volume | Weight |
|----------|--------|-----|----------|--------------------|------------------------|--------|
|          |        | Nr. | Nr       | [dm <sup>3</sup> ] | [dm <sup>3</sup> ]     | (kg)   |
| Medium   | MCM080 | 2   | 1        | 7                  | 12,5                   | 260    |
| Large    | MCL055 | 1   | 1        | 5                  | 12,5                   | 205    |
|          | MCL110 | 2   | 1        | 11,6               | 12,5                   | 335    |
|          | MCL165 | 3   | 1        | 19,4               | 21                     | 475    |

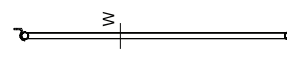
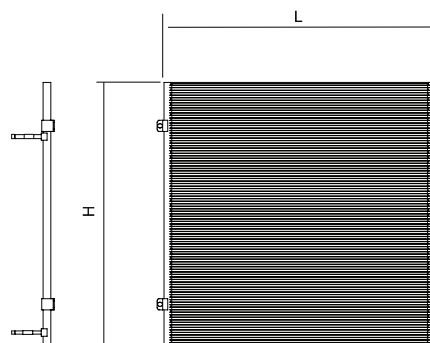

### 6.3 Installation Dimensions

| Model  | Dimension (LxWxH) |        |        |
|--------|-------------------|--------|--------|
|        | L [mm]            | W [mm] | H [mm] |
| MCM080 | 2606              | 1432   | 2108   |
| MCL055 | 1678              | 1603   | 2262   |
| MCL110 | 3104              | 1603   | 2262   |
| MCL165 | 4529              | 1603   | 2262   |

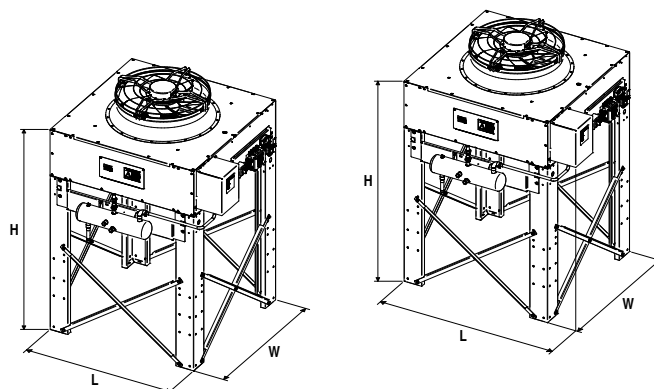

## 7. Handling

### 7.1 Safety Instructions



#### WARNING

Improper handling can cause injury or death.

Only authorized personnel is allowed to move, lift, remove packaging from or prepare the unit for installation.

The authorized personnel must be properly trained and qualified, wear appropriate personal protective equipment and use adequate moving equipment (cranes, forklift, etc.).



#### WARNING

Make sure to use transport and lifting equipment rated for the unit dimensions and weight.

See *Annex II – Dimensions and Weight*



#### WARNING

Never walk or stay below a suspended load.



#### CAUTION

Sharp edges, splinters and exposed fasteners.

Wear protective gloves before operating on the unit.



#### NOTICE

Improper handling can cause product damage.

### 7.2 Inspection

- After receiving the product, check the accessories against the packing list.
- If any parts are found missing or damaged, please report to the carrier immediately.
- If you find any damage, please report to the carrier and to the local distributor too.

### 7.3 Storage

You may keep the unit in a storehouse with the following ambient conditions:

| Item                | Requirement                                                                                                |
|---------------------|------------------------------------------------------------------------------------------------------------|
| Storage environment | Clean (no dust), well-ventilated indoor environment.                                                       |
| Ambient temperature | -40°C – +70°C                                                                                              |
| Ambient humidity    | 5%RH – 85%RH                                                                                               |
| Storage time        | The total storage time should not exceed six months. Otherwise, the performance needs to be re-calibrated. |



#### NOTICE

These requirements are valid only for the unit without refrigerant charge.

If the microchannel condenser is assembled with the main unit and the whole system is charged with refrigerant, and then put in a storehouse, there is a risk of overpressure in a lower ambient temperature range.

Please refer to the main unit manuals for allowed ambient temperatures with refrigerant charge.

## 7.4 Transport - with Package

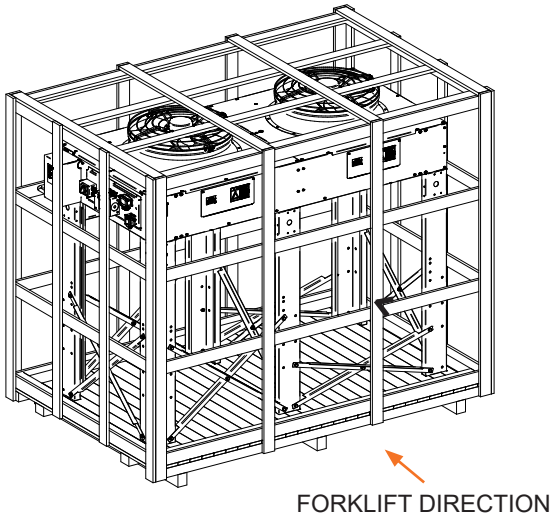

Use mechanical transport equipment such as a forklift or a crane when unloading or moving the packed unit to the installation site.

When a forklift is used to unload and move the packed unit:

- Insert the tines of the forklift following the direction shown in the figure.

## 7.5 Unpacking

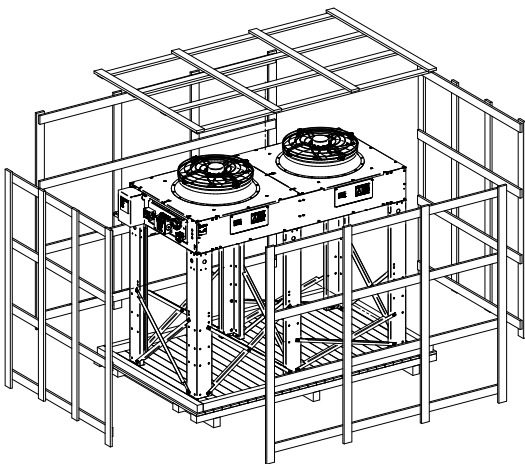

- Remove the exterior packaging material from around the unit.

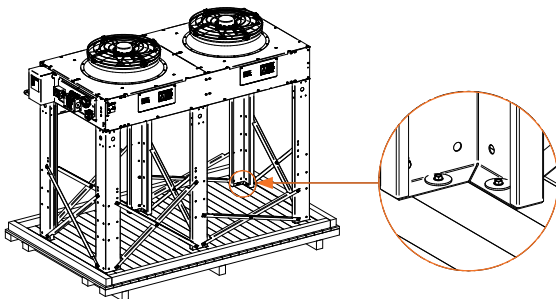

- Remove the bolts securing the unit to the pallet.

## 7.6 Transport - without Package

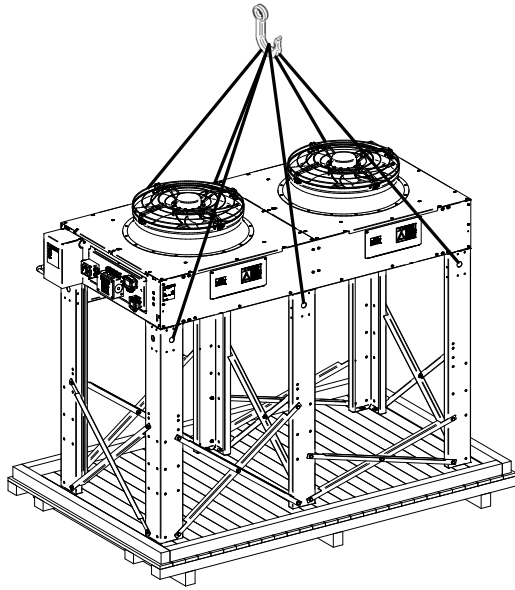

Use a crane to move condensers.

- Fix the slings by lading through the slot at the condenser's legs.
- Make sure to use slings rated for the unit weight.

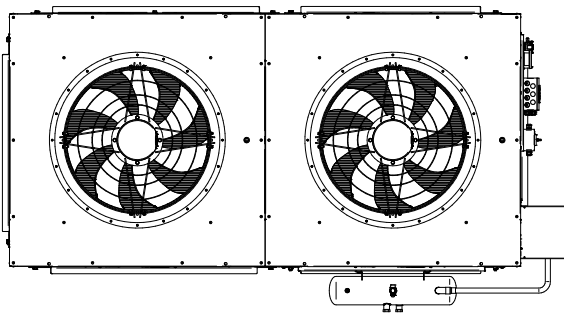

## 8. Installation

### 8.1 Overview

The unit is delivered fully assembled at the factory, including all the internal wiring.  
 The following operations must be done at the installation site:

| Operation                                                                                   | See ...                                |
|---------------------------------------------------------------------------------------------|----------------------------------------|
| Position the unit at the final location and fix it on the floor or the supporting structure | 8.3 Location<br>8.4 Space Requirements |
| Connect the piping to the main unit                                                         | 8.5 Piping                             |
| Connect the main switch to the electric power supply                                        | 8.6 Electrical Connections             |

### 8.2 Safety Instructions



#### WARNING

Only authorized personnel is allowed to do installation operations.  
 The authorized personnel must be properly trained and qualified, wear appropriate personal protective equipment and use adequate tools.



#### CAUTION

Sharp edges, splinters and exposed fasteners.  
 Wear protective gloves before operating on the unit.



#### NOTICE

Improper handling can cause product damage.

### 8.3 Location

Condensers should be installed in a location offering maximum security and access for maintenance.

The service area must be respected.

Avoid areas prone to heavy snow or ice accumulations.

The installation site must guarantee a sufficient dispersion of the air to allow operation in even the severest conditions. **Vertiv™** recommends that condensers to be installed in an area with clean air, away from loose dirt and foreign matter that might clog the coil.

For roof installation, mount the condenser on suitable curbs or other supports in accordance with local rules.

Follow the installation arrows on the condenser for the installation.

#### Horizontal installation (vertical air flow):

- In order to allow sufficient air through the unit and space for any eventual maintenance, The Service Area should be left free of obstructions.
- With vertical air flow installation, a free area of at least 4 m above the condenser has to be guarantee for a correct air circulation with the aim to avoid shot-cut from discharge to suction air side of condenser.

## 8.4 Space Requirements

The condenser needs sufficient installation and service space around the installation place. The detailed space requirements are shown in Figures below



### NOTICE

The unit does not operate correctly if placed too close to walls or other obstacles.

#### 8.4.1 Placement Options and Piping Restrictions for the Liebert® EconoPhase and Air-Cooled Condenser

The **Liebert® MC** condenser and **Liebert® EconoPhase** must be installed next to each other (see *Tables 8.1* and *8.2* for guide-lines). The **Liebert® EconoPhase** is dependent on subcooled liquid leaving the condenser and entering the pumps. For this reason there must be no large pressure drop between the two units because that could lead to flashing of the refrigerant and pump cavitation. There must be no traps in the liquid line between the condenser and the **Liebert® EconoPhase** module because these will allow vapor to enter the pump suction during startup.

Fig. 8.1 - Relative heights of condenser and Liebert® EconoPhase

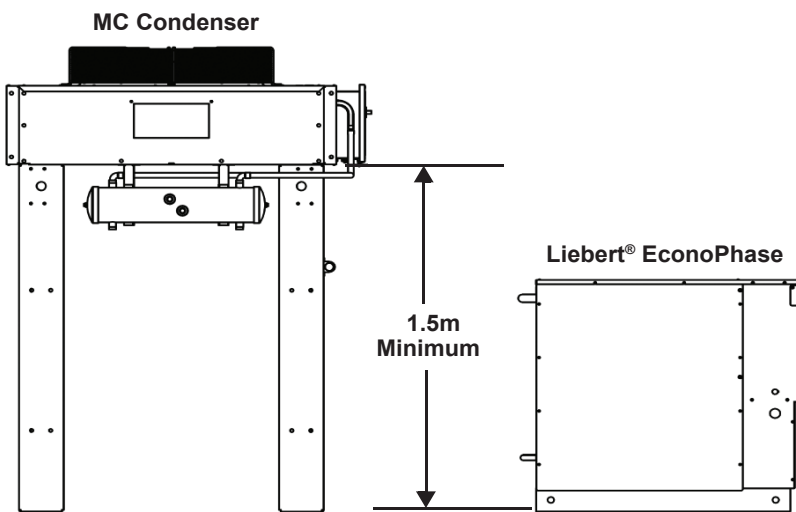

Tab. 8.1 - Field piping restrictions between air-cooled condenser and Liebert® EconoPhase

| Line Size<br>Outdoor Diameter<br>mm | Maximum Equivalent Length<br>between Condenser and PRE<br>m | Minimum Height<br>Condenser to PRE module (see <i>Figure 8.1</i> )<br>m |
|-------------------------------------|-------------------------------------------------------------|-------------------------------------------------------------------------|
| 35                                  | 7,6                                                         | 1,5                                                                     |

Tab. 8.2 - Condenser height restrictions relative to Liebert® PDX

| Maximum Height of Condenser above the Liebert® PDX (see <i>NOTE</i> below)<br>m |
|---------------------------------------------------------------------------------|
| 18,0                                                                            |

**NOTE** The condenser must not be installed below the level of the **Liebert® PDX**. The condenser may be installed on the same level as the **Liebert® PDX** or as much as 18.0m above the **Liebert® PDX**.

Fig. 8.2 - Piping schematic

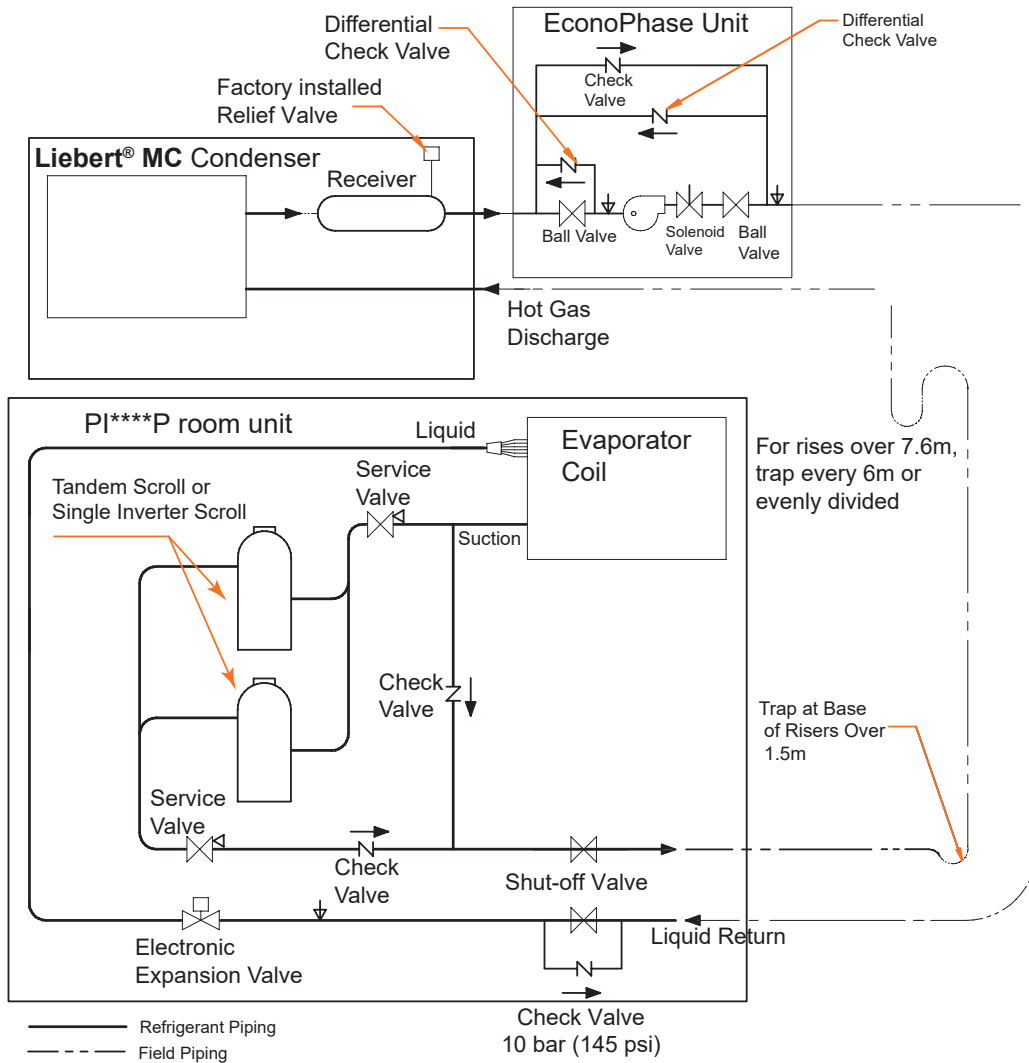

1. Two refrigeration circuits provided. Single refrigeration circuit shown for clarity.
2. Schematic representation shown. Do not use for specific connection locations.
3. Vertical height of condenser above indoor unit shall be no greater than 18.0m.
4. All indoor and outdoor field refrigerant piping must be insulated, 12mm minimum thickness. All outdoor insulation must be UV- and ozone-resistant

### 8.4.2 Horizontal Installation

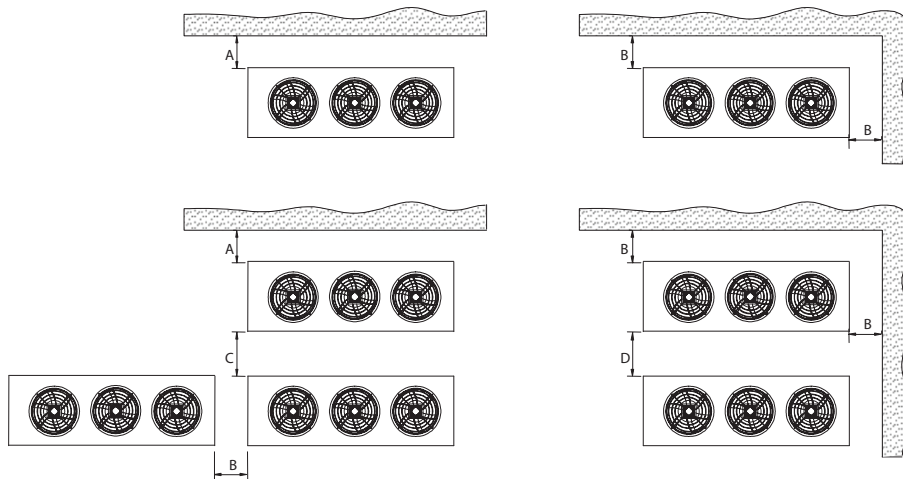

| Model  | Horizontal installation |      |      |      |
|--------|-------------------------|------|------|------|
|        | A                       | B    | C    | D    |
| MCL055 | 627                     | 784  | 940  | 1254 |
| MCM080 | 709                     | 886  | 1064 | 1418 |
| MCL110 | 847                     | 1059 | 1271 | 1695 |
| MCL165 | 1020                    | 1275 | 1530 | 2040 |

## 8.5 Piping

### Release the pressure



#### WARNING

**The circuit is pressurized by nitrogen/helium at 2 bar.**

Before welding the pipeline, discharge completely the circuit to release the pressure.

### Connections

The inlet and outlet directions are clearly marked with labels and arrows on the respective pipings. Pay attention to follow the directions.

### Take care of the sensors

While welding the pipeline, take care to disconnect the pressure transducer and the temperature sensor. Re-connect the pressure transducer and the temperature sensor once the welding operation is completed and the pipes have cooled down. Not present with Control by Indoor Unit.

### Piping sizes

| Model  | Pipe IN | Pipe OUT |
|--------|---------|----------|
| MCL055 | 28      | 35       |
| MCM080 | 28      | 35       |
| MCL110 | 35      | 35       |
| MCL165 | 35      | 35       |

### Keep clean

- Keep piping clean and dry.
- Ensure that the tubing surfaces to be brazed are clean and that the ends of the tubes have been carefully reamed to remove any burrs.
- Ensure that all loose material has been cleaned from inside the tubing before brazing.

### Brazing

**NOTE** - When copper is heated in the presence of air, copper oxide forms. POE oil will dissolve these oxides from inside the copper pipes and deposit them throughout the system, clogging filter driers and affecting other system components.

- Use copper piping with a brazing alloy with a minimum temperature of 732°C, such as Sil-Fos.
- Avoid soft solders such as 50/50 or 95/5.
- During brazing use pure dry nitrogen through the piping with a flow of 0.5-1.5 l/s

### Vibration

- Isolate piping from building using vibration isolating supports.

### Refrigerant charge



#### NOTICE

A not adequate charge of refrigerant could bring to inappropriate work of the refrigeration system.

Refer to the main unit user manual for the refrigerant charge operation.

## 8.6 Electrical Connections

### 8.6.1 General Instructions

#### Specifications

- Check the electrical data on the label applied on the unit.
- Check that the available power supply is consistent with the unit power requirements given in *6.1 Technical Data and Performances*.
- Refer to the electrical schematic supplied with the condenser when making line voltage supply, low voltage main unit interlock and any low voltage alarm connections.
- Make sure all electrical connections are tight.
- Electrical service must conform to national and local electrical codes.
- All wiring must be done in accordance with all applicable local, state, and national electrical codes.
- Use copper wiring only.
- For specific electrical requirements, see the electrical schematic provided with the unit.
- The voltage supply to the condenser might be different from voltage supply to the main unit.

#### Outdoor

- The protection tube or shielded line is required for the outdoor part of the connecting cable between the main unit and the condenser.

|                                            |                                                                                                                                                                                                                                                                                                                                                                                                                                |
|--------------------------------------------|--------------------------------------------------------------------------------------------------------------------------------------------------------------------------------------------------------------------------------------------------------------------------------------------------------------------------------------------------------------------------------------------------------------------------------|
| <b>Sealing</b>                             | <ul style="list-style-type: none"> <li>When leading the cable through the joint, you are recommended to use the sealant for waterproof disposal.</li> <li>If you do not follow the recommended cable sizes and mode to connect the cables, water leakage may occur at the waterproof joint.</li> </ul>                                                                                                                         |
| <b>Hot surfaces</b>                        | <ul style="list-style-type: none"> <li>The cables cannot contact with hot objects, such as the copper pipe and water pipe without thermal insulation pipe, lest the insulation layers should be damaged.</li> </ul>                                                                                                                                                                                                            |
| <b>Disconnecting switch and protection</b> | <ul style="list-style-type: none"> <li>A manual electrical disconnect switch should be installed in accordance with local codes.</li> <li>Select and install the line side electrical supply wire and over current protection device(s) according to the specifications on the unit nameplate(s), per the instructions in this manual and according to the applicable national, state, and local code requirements.</li> </ul> |

## 8.6.2 Connection to the Power Supply

### Specifications for MC equipped with EC fans

#### Use WYE power supply connection

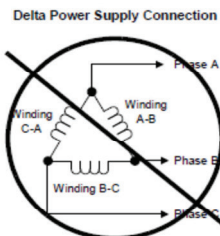
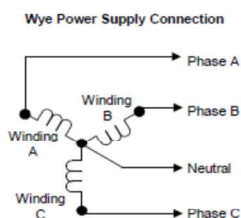

#### NOTICE

The **Liebert® MC** Condenser equipped with EC Fan Models is designed to operate with Wye-connected power.

It will not operate properly with Delta connected power.

The neutral is for illustration purpose only and is not necessary for the condenser to function properly.

A field-supplied isolation transformer or other power solutions will be needed to for proper condenser function.

The electronically commutated motors included in the **Liebert® MC** are suitable for connection to power supplies with a solidly grounded neutral.

#### Acceptable Power Supplies - 380V to 460V Nominal Units

- 380V wye with solidly grounded neutral and 220V line-to-ground
- 460V wye with solidly grounded neutral and 277V line-to-ground

#### Unacceptable Power Supplies - 380V to 460V Nominal Units

- Wye with high-resistance (or impedance) ground
- Delta without ground or with floating ground
- Delta with corner ground
- Delta with grounded center tap

### Wiring Instructions

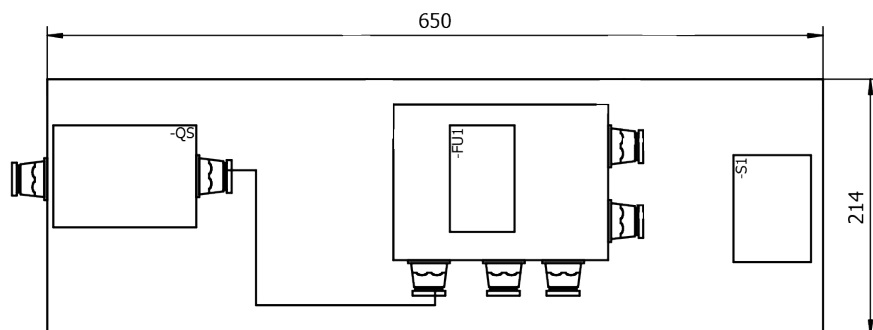

1. Route the power supply cable to the site disconnect switch and then to the unit.
2. Route the conduit to the knockout provided in the bottom right end of the electrical control enclosure.
3. Connect the earth ground wire lead to the marked earth ground connection terminal provided near the factory-installed disconnect switch.
4. Connect the three-phase cable to the factory-installed disconnect switch.

### 8.6.3 Controlled by indoor Unit



#### NOTICE

Risk of control malfunction.

Can cause improper unit operation.

Make sure that all low voltage electrical wiring has been performed per the schematic diagram provided and that all low voltage wiring connections are tight.

### Specifications

#### Modbus

**Liebert® MC** remote condensers are designed to use Modbus communication between **Liebert® MC** and **Liebert® iCOM™** control on main unit.

#### Modbus length restrictions

Do not run the Modbus cable in the same conduit, raceway or chase used for high-voltage wiring. For Modbus network lengths greater than 130m, please contact Vertiv™ Technical Support.

#### Modbus cable specifications:

The Modbus wiring is field-supplied and must be:

- shielded
- 24-18 AWG (0.5 mm<sup>2</sup>) stranded tinned copper until 107m, 18-16 AWG (0.75 mm<sup>2</sup>) stranded tinned copper until 130m
- twisted pair (minimum 8 twists per foot)
- low capacitance (17pF/ft or less)
- plenum rated (NEC type CMP) if required by local codes
- UV and moisture resistant or run within conduit once in an outdoor environment, and must be temperature and voltage rated for conditions present.

**Examples:** Belden part number 89207(plenum rated) or Alpha Wire part number 6454 (UV resistant outdoor rated) category 5, 5e or higher.



#### CAUTIONS

Do not run the Modbus cable in the same conduit, raceway or chase used for high-voltage wiring.

#### Addressing

All the **MC** condensers are shipped with standard fan addressing: 31, 32 (up to 4 fans). In case of dual circuit units, it is required to change the addressing of fan of the second circuit in 41, 42, 43, 44, respectively.

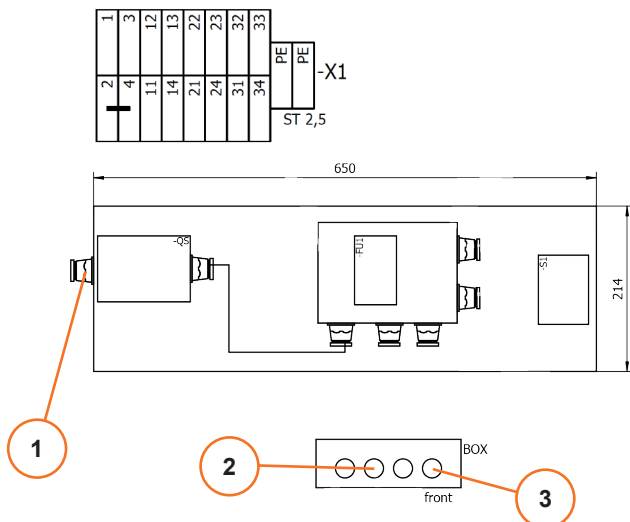

|   |                               |                 |
|---|-------------------------------|-----------------|
| 1 | Primary high-voltage entrance | M20 cable gland |
| 2 | Modbus IN                     | M20 cable gland |
| 3 | Modbus OUT                    | M20 cable gland |

## 9. Unit Controller

### 9.1 Controlled by Indoor Unit

#### 9.1.1 Condensing Unit Change Address Procedure

The Control Firmware shall offer the possibility to change the modbus address of one condensing unit which pre-set address is known.

The change address procedure shall be applied in two circumstances:

1. Commissioning of a system with two condensing units, C1 and C2, which are powered through dedicated circuit breaker in the Electric Panel.
2. Replacement of a broken fan from Service with a new one pre-addressed with a known address (e.g. 50).

The procedure number one shall be dedicated to the change of the factory programmed addresses of the fans of the circuit number two, that in origin are identical to the ones of the circuit number one (31, 32, 33, 34).

The Firmware shall have one dedicated page in the Service Menu. The user shall confirm that C1 circuit breaker is **OFF** and C2 is **ON**.

Then the operation shall occur for each fan connected, changing 31 to 41, 32 to 42, 33 to 43, 34 to 44. The user is finally told to do a power cycle of the fans with at least **20** seconds of **OFF** Power to memorize the new addresses.

The replacement of a broken fan with a new one is achieved connecting to fan of address number 50 (the new one installed by service). On connection detection a new page for changing the address shall be open asking for the new address. When it is confirmed the user is finally told to do a power cycle of the fans with at least **20** seconds of **OFF** Power to memorize the new address.

# 10. Maintenance



## NOTICE

Check the unit regularly and solve the problems as they occur.  
Lack of maintenance could reduce the performance or damage the unit.

## 10.1 Safety Instructions

### Personnel



#### WARNING

Only authorized personnel is allowed to do maintenance operations.  
The authorized personnel must be properly trained and qualified, wear appropriate personal protective equipment and use adequate tools.

### Electric System



#### WARNING

Unit contains potentially lethal voltage in some circuits.  
Risk of arc flash and electric shock.  
Can cause injury or death.

- Open all local and remote unit electric power disconnect switches, verify with a voltmeter that power is **OFF** and wear protective equipment per local standard before working within the electric control enclosure.



#### WARNING

The electric connection enclosures, the fan speed control and the EC fan enclosures can retain a stored high-voltage electrical charge for up to **10** minutes.  
Risk of electric shock.  
Can cause serious injury or death.

Before working within the unit electric connection enclosures or working within the fan speed control and the EC fan enclosures proceed as follows:

- open all local and remote unit electric power disconnect switches
- wait **10** minutes
- verify with a voltmeter that power is **OFF**

Only properly trained and qualified personnel may perform repair, maintenance and cleaning.

### Automatic Restart



#### WARNING

Fan blades can automatically start rotating without warning at any time during a cooling cycle or after power is restored after a power failure.

Risk of contact with high-speed, rotating fan blades.

Can cause serious personal injury or death.

Before working within the unit cabinet, removing the fan guards or servicing the fan speed control, fan blades or EC fan motors proceed as follows:

- open all local and remote electric power supply disconnect switches
- wait **10** minutes
- verify with a voltmeter that power is **OFF**



#### WARNING

This unit operates and restarts automatically.

The fans may suddenly start blowing out a strong air flow, which may carry particles and small objects from inside the unit.

Can cause serious personal injury.

- Wear eyes protection when you need to get close to the unit while it is operating.
- Turn the main switch to **OFF** to disconnect the unit from the power supply before any operation on the unit.

**Personal Protective Equipment**



**CAUTION**  
The microchannel condenser is made of plates and fins, which may have sharp edges and blurr. • Always wear cut resistant gloves when operating on the condenser.



**CAUTION**  
Components at high temperature (condenser inlet piping at about 120°C). • Always wear temperature resistant gloves when operating on the condenser.

## 10.2 Safety Labels

- Check regularly that the safety label are still on the unit and clearly visible. See *Annex III – Safety Labels* for safety label mapping. Replace any missing or damaged label.

## 10.3 Refrigeration System

- Check that the refrigeration pipes are firmly fixed. The refrigeration pipes shall not shake with the vibration of wall, earth or equipment frame. Otherwise reinforce the refrigeration pipes with fasteners.
- Check that there is no oil on the accessories of all refrigeration pipes, and make sure that the pipes do not leak.

## 10.4 Heat Exchanger

- Check and clean the coil at least every three months.



**NOTICE**  
Keeping the coil dirty means less performance and risk of corrosion of pipes.



**NOTICE**  
Avoid snow accumulation around the condenser in winter.

### 10.4.1 Opening the Cleaning Windows

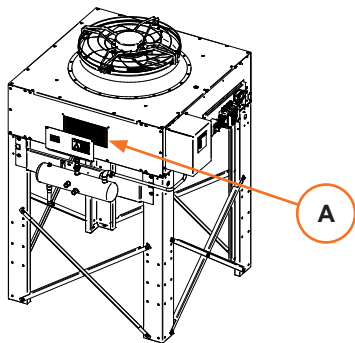

The coil is accessible for cleaning through the innovative cleaning window design (A), allowing you to clean the coil without removing the fans from the unit.

1. Disconnect the power supply before working on the unit.
2. Remove the cover panels to free the cleaning windows.
3. Loose the mounting screws to open the cleaning windows.

### 10.4.2 Cleaning

#### What to use

|                    |                                                                                                                                                                                                                                                                          |
|--------------------|--------------------------------------------------------------------------------------------------------------------------------------------------------------------------------------------------------------------------------------------------------------------------|
| <b>Plain water</b> | <b>Vertiv™</b> highly recommends to use plain water to clean the coils. Water pressure from a garden hose and sprayer usually works well. If the coil has been maintained and cleaned at regular intervals, water is sufficient to remove dirt and debris from the fins. |
| <b>Brush</b>       | You may use a brush to remove heavy build up on the exterior of the fins.                                                                                                                                                                                                |

**Pressure washer**

If you use a pressure washer, make sure the equipment is set to a lower pressure setting and that the nozzle is set to the fan spray, not stream. Otherwise, damage to the fins could result.



**NOTICE**

The recommended flushing water flow is 400 l/hour.  
Higher water flow would damage the fin of the heat exchanger.

**Neutral cleaner**

If a cleaner is required, it is recommended to use a neutral cleaner.

- Do not use any of the following type of cleaners:
  - acid-type cleaners
  - base-type cleaners
  - sodium hydroxide based cleaners
  - paint solvents (including non-base type)



**NOTICE**

Using a wrong type of cleaning agents can produce the following effects:

- damage to the coil fins
- damage to the surrounding structure
- loss of refrigerant charge
- property damage in general

The cleaner will spread in the surrounding area.

- Check the cleaner instructions and you use it according to the site environmental regulations.



**NOTICE**

Many sites do not allow the use of acidic cleaners for environmental reasons.

## 10.5 Fans

**Inspection**

- Check whether the fan runs normally

In case of problems such as abnormal noise, vibration and bearing failure: contact **Vertiv™** or an **Vertiv™** authorized service center.

**Replacement**

- Make reference to the fan manufacturer instructions for transport, handling and mounting the fans.



**WARNING**

The fans are heavy and mounted at some height.  
Use adequate lifting equipment and follow the fan manufacturer instructions for handling.

## 11. Troubleshooting

| Symptom                         | Possible Cause                                                              | Check or Remedy                                                               |
|---------------------------------|-----------------------------------------------------------------------------|-------------------------------------------------------------------------------|
| <b>Condenser will not start</b> | No power to condenser.                                                      | Check voltage at input terminal block.                                        |
|                                 | Circuit breaker or fuse for low-voltage transformer in condenser is tripped | Locate problem in condenser electrical panel and repair.                      |
|                                 | No low-voltage signal to/from indoor unit.                                  | Locate open circuit and repair.                                               |
|                                 | Missing Modbus communication (only for Controlled Indoor Unit).             | Check the cable connection.<br>Check if the fans have the correct addressing. |
| <b>Low discharge pressure</b>   | Faulty head pressure control valve or premium efficiency control board.     | Replace if defective.                                                         |
| <b>High discharge pressure</b>  | Dirty condenser fins.                                                       | Check for low-voltage signal from indoor unit.                                |
|                                 | Condenser fans not operating.                                               | Check fan motors and fuses.                                                   |
|                                 | High refrigerant charge                                                     | Check refrigerant charge.                                                     |
| <b>Fan will not run</b>         | Jumper not installed between 24V and DIN1 (for Ziehl-Abegg fan motor).      | Install jumper between 24V and DIN1 (for Ziehl Abegg fan motor).              |

## 12. Dismantling the unit

The machine has been designed and built to ensure continuous operation.

The working life of some of the main components, such as the fan, depends on the maintenance that they receive.

The machine must be dismantled if it is moved to another site, or at the end of its technical and operational life.



### NOTICE

The unit contains substances and components hazardous for the environment (electronic components, lead gel battery, refrigerating gases and oils).

At the end of the useful life, when the unit is dismantled, the operation must be carried out by specialized refrigerating technicians.

The unit must be delivered to suitable centers specialized for the collection and disposal of equipment containing hazardous substances.

The lead gel battery, refrigeration fluid and the lubricating oil inside the circuit must be recovered according to the laws in force in the relevant country.

### 12.1 Safety Instructions

#### Personnel



#### WARNING

Only authorized personnel is allowed to do dismantling operations.

The authorized personnel must be properly trained and qualified, wear appropriate personal protective equipment and use adequate tools.

#### Electric System



#### WARNING

Unit contains potentially lethal voltage in some circuits.

Risk of arc flash and electric shock.

Can cause injury or death.

- Open all local and remote unit electric power disconnect switches, verify with a voltmeter that power is **OFF** and wear protective equipment per local standard before working within the electric control enclosure.



#### WARNING

The electric connection enclosures, the fan speed control and the EC fan enclosures can retain a stored high-voltage electrical charge for up to **10** minutes.

Risk of electric shock.

Can cause serious injury or death.

Before working within the unit electric connection enclosures or working within the fan speed control and the EC fan enclosures proceed as follows:

- open all local and remote unit electric power disconnect switches
- wait **10** minutes
- verify with a voltmeter that power is **OFF**

Only properly trained and qualified personnel may perform repair, maintenance and cleaning.

#### Personal Protective Equipment





#### CAUTION

The microchannel condenser is made of plates and fins, which may have sharp edges and blurs.

- Always wear cut resistant gloves when operating on the condenser.

## 12.2 Operations

| Operation                                                    | Notes                                                                                                                                                                                                                                          |
|--------------------------------------------------------------|------------------------------------------------------------------------------------------------------------------------------------------------------------------------------------------------------------------------------------------------|
| 1. Disconnect the main switch from the electric power supply | Reverse the procedure from chapter 8. <i>Installation</i>                                                                                                                                                                                      |
| 2. Disconnect the Premium Controller from the main unit      | 8.6 <i>Electrical Connections</i>                                                                                                                                                                                                              |
| 3. Remove the refrigerant                                    |  <b>NOTICE</b><br>Handle the refrigerant according to regulations about F-Gases and safety data sheet.<br>See 13. <i>Regulation (EU) no. 517/2014 (F-gas)</i> |
| 4. Cut the piping at inlet and outlet of the unit            |  <b>WARNING</b><br>Before cutting the pipeline, make sure that the circuit is completely discharged.                                                          |
| 5. Remove the fixing bolts                                   | Reverse the procedure from chapter 7.5 <i>Unpacking</i>                                                                                                                                                                                        |
| 6. Move away the unit                                        | See 7.0 <i>Handling</i>                                                                                                                                                                                                                        |
| 7. If you need to keep the unit in a storehouse for reuse    | See 7.3 <i>Storage</i>                                                                                                                                                                                                                         |
| 8. If you need to scrap the unit                             | Handle to authorized disposal company according to the local regulations about waste disposal.                                                                                                                                                 |

## 13. Regulation (EU) no. 517/2014 (F-gas)

### 13.1 Introduction

Stationary air conditioners placed into the European Community market and operating with fluorinated greenhouse gases (F-gas, such as R407C, R134a, R410A), have to comply with the F-gas Regulation (EU) No. 517/2014.

This Regulation is in force since Jan 1, 2015 and it replaces the Re. (EU) no. 342/2006.

This document summarizes the obligations for the operators that are responsible for the equipment during all its operative life until its disposal.

### 13.2 Normative References

|                                           |           |                                                                                                                                                                                                                                                                                                                                                                                                                                                                                                                                                                                                                                      |
|-------------------------------------------|-----------|--------------------------------------------------------------------------------------------------------------------------------------------------------------------------------------------------------------------------------------------------------------------------------------------------------------------------------------------------------------------------------------------------------------------------------------------------------------------------------------------------------------------------------------------------------------------------------------------------------------------------------------|
| <b>F-gas</b>                              | 517/2014  | Regulation (EU) No 517/2014 of the European Parliament and of the Council of 16 April 2014 on fluorinated greenhouse gases and repealing Regulation (EC) No 842/2006                                                                                                                                                                                                                                                                                                                                                                                                                                                                 |
| <b>Certified personnel and Companies</b>  | 2015/2067 | Commission Implementing Regulation (EU) 2015/2067 of 17 November 2015 establishing, pursuant to Regulation (EU) No 517/2014 of the European Parliament and of the Council, minimum requirements and the conditions for mutual recognition for the certification of natural persons as regards stationary refrigeration, air conditioning and heat pump equipment, and refrigeration units of refrigerated trucks and trailers, containing fluorinated greenhouse gases and for the certification of companies as regards stationary refrigeration, air conditioning and heat pump equipment, containing fluorinated greenhouse gases |
| <b>Leak check air conditioning</b>        | 1516/2007 | Commission Regulation No 1516/2007 of 19 December 2007 establishing, pursuant to Regulation (EC) No 842/2006 of the European Parliament and of the Council, standard leakage checking requirements for stationary refrigeration, air conditioning and heat pump equipment containing certain fluorinated greenhouse gases                                                                                                                                                                                                                                                                                                            |
| <b>Leak check fire protection systems</b> | 1497/2007 | Commission Regulation No 1497/2007 of 18 December 2007 establishing, pursuant to Regulation (EC) No 842/2006 of the European Parliament and of the Council, standard leakage checking requirements for stationary fire protection systems containing certain fluorinated greenhouse gases                                                                                                                                                                                                                                                                                                                                            |

From 01/01/2017 to be replaced by:

Commission Implementing Regulation (EU) 2015/2068 of 17 November 2015 establishing, pursuant to Regulation (EU) No 517/2014 of the European Parliament and of the Council, the format of labels for products and equipment containing fluorinated greenhouse gases

### 13.3 Fluorinated Greenhouse Gases

Following notes have to be considered when operating with the above mentioned equipments:

- Fluorinated greenhouse gases are covered by the Kyoto Protocol.
- The fluorinated greenhouse gases in this equipment should not be vented to the atmosphere.
- Referring to the value noted in Annex I and Annex IV of Regulation (EU) No 517/2014 here below the global warming potential (GWP) of some major F-gases or mixtures:
  - R-134a GWP 1430
  - R-407C GWP 1774
  - R-410A GWP 2088

**NOTE:** the refrigerants as R22 are not F-gas and their relevant regulation is Reg. (EU) no. 1005/2009.

## 13.4 Operators

### 13.4.1 Definitions

- Operator, according to Regulation 517/2014 Article 2, point 8, means the natural or legal person exercising actual power over the technical functioning of products and equipment covered by this Regulation.
- The State may, in defined, specific situations, designate the owner as being responsible for the operator's obligations.
- Where large installations are involved, service companies are contracted to carry out maintenance or servicing. In these cases the determination of the operator depends on the contractual and practical arrangements between the parties.

### 13.4.2 Obligations

Operators of stationary air conditioners, which contain fluorinated greenhouse gases, shall, using all measures which are technically feasible and do not entail disproportionate cost:

- Prevent leakage of these gases and as soon as possible repair any detected leakage.
- Ensure that they are checked for leakage by certified personnel.
- Ensure for putting in place arrangements for the proper recovery by certified personnel.
- According to Regulation 517/2014 the operators shall ensure that the equipment is checked for leaks as following:
  - Case 1** - Non-sealed equipment contains less than 5 tonnes of CO<sub>2</sub> equivalent of fluorinated greenhouse gases.
    - ▶ Leakage test not required
  - Case 2** - Hermetically sealed equipment contains less than 10 tonnes of CO<sub>2</sub> equivalent of fluorinated greenhouse gases.
    - ▶ Leakage test not required
  - Case 3**
    - ▶ **Leakage test required:** check the equipment for leaks with the minimum frequency given in the following table:

| X = Tonnes of CO <sub>2</sub> Equivalent | Y = equivalent amount of refrigerant [kg] |              |              | Minimum frequency for leak check |                        |
|------------------------------------------|-------------------------------------------|--------------|--------------|----------------------------------|------------------------|
|                                          | R134a                                     | R410A        | R407C        | without leakage detection        | with leakage detection |
| 5 ≤ X < 50                               | 3,5 ≤ Y < 35                              | 2,4 ≤ Y < 24 | 2,8 ≤ Y < 28 | 12 Months                        | 24 Months              |
| 50 ≤ X < 500                             | 35 ≤ Y < 350                              | 24 ≤ Y < 240 | 28 ≤ Y < 282 | 6 Months                         | 12 Months              |
| X ≥ 500                                  | Y ≥ 350                                   | Y ≥ 240      | Y ≥ 282      | 3 Months                         | 6 Months               |

- Recovery for the purpose of recycling, reclamation or destruction of the fluorinated greenhouse gases, pursuant to Art. 8 of the Regulation 517/2014 shall take place before the final disposal of that equipment and, when appropriate, during its servicing and maintenance.

## 13.5 Leakage Detection

The manufacturer approves the following leakage check methods according to Reg. 1516/2007 and Reg. 1497/2007:

| Method                                                                                                                                | Specifications                                                                                                                                                                                |
|---------------------------------------------------------------------------------------------------------------------------------------|-----------------------------------------------------------------------------------------------------------------------------------------------------------------------------------------------|
| a Check of circuits and components representing a risk of leakage with gas detection devices adapted to the refrigerant in the system | Gas detection devices shall be checked every <b>12</b> months to ensure their proper functioning.<br>The sensitivity of portable gas detection devices shall be at least five grams per year. |
| b Application of ultraviolet (UV) detection fluid or suitable dye in the circuit                                                      | The method shall only be undertaken by personnel certified to undertake activities which entail breaking into the refrigeration circuit containing fluorinated greenhouse gases.              |
| c Proprietary bubble solutions/soapsuds                                                                                               | ---                                                                                                                                                                                           |

## 13.6 Labelling

The label applied on the unit (see *Onboard Label*) is designed to fill-in the relevant amounts of refrigerant according to Regulation 1494/2007 (2015/2068):

- a Where fluorinated greenhouse gas is foreseen to be added to the equipment outside of the manufacturing site at the point of installation, a dedicated label accommodates notation of both the quantity [kg] pre-charged in the manufacturing plant and of the quantity charged at the installation site as well as the resulting total quantity of F-gas as a combination of the above mentioned quantities, in a manner which conforms to the legibility and indelibility.

Our split units are usually not pre-charged on factory, in this case the total quantity of refrigerant charged in the unit has to be written in the relevant label, during the commissioning operation at the installation site.

All of the quantities of must be given both as mass of refrigerant [kg] and as Tonnes of CO<sub>2</sub> Equivalent.

Use the following rule for computation:

$$\text{Tonnes of CO}_2 = \frac{\text{kg of refrigerant} \times \text{GWP of refrigerant}}{1000}$$

where:

| Refrigerant | GWP  |
|-------------|------|
| R-134a      | 1430 |
| R-407C      | 1774 |
| R-410A      | 2088 |

- b Our packaged units (not split) operating with f-gas are usually full charged on factory and the total amount of refrigerant charge is already reported on the label. In this case, the label has no need of further written information.
- c In general, the above mentioned information has been located in the main nameplate of relevant unit.
- d For equipment with double refrigeration circuits, in regards to differentiates requirements on the basis of the quantity of F-gas contained, the required information about refrigerant charge quantities has to be listed separately for each individual circuit
- e For equipments with separate indoor and outdoor sections connected by refrigerant piping, the label information will be on that part of the equipment which is initially charged with the refrigerant. In case of a split system (separate indoor and outdoor sections) without a factory pre-charge of refrigerant, the mandatory label information will be on that part of the product or equipment which contains the most suitable service points for charging or recovering the fluorinated greenhouse gas(es).

**NOTE:** *Safety data sheets of F-gases used in the products are available on demand.*

## 13.7 Record Keeping

Operators of equipment which is required to be checked for leaks (see *12.5 Leakage Detection*), shall establish and maintain records for each piece of such equipment specifying the following information:

- a the quantity and type of fluorinated greenhouse gases installed
- b the quantities of fluorinated greenhouse gases added during installation, maintenance or servicing or due to leakage
- c whether the quantities of installed fluorinated greenhouse gases have been recycled or reclaimed, including the name and address of the recycling or reclamation facility and, where applicable, the certificate number
- d the quantity of fluorinated greenhouse gases recovered
- e the identity of the undertaking which installed, serviced, maintained and where applicable repaired or decommissioned the equipment, including, where applicable, the number of its certificate
- f the dates and results of the leak checks carried out (see *12.5 Leakage Detection*)
- g if the equipment was decommissioned, the measures taken to recover and dispose of the fluorinated greenhouse gases

Unless the records are stored in a database set up by the competent authorities of the Member States the following rules apply:

- a the operators shall keep the records for at least **five** years
- b undertakings carrying out activities for operators shall keep copies of the records for at least **five** years

# Annex I – Dimensions and Weight

MCL 055

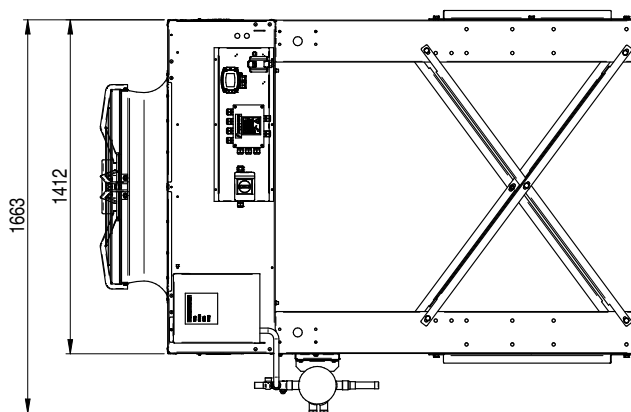
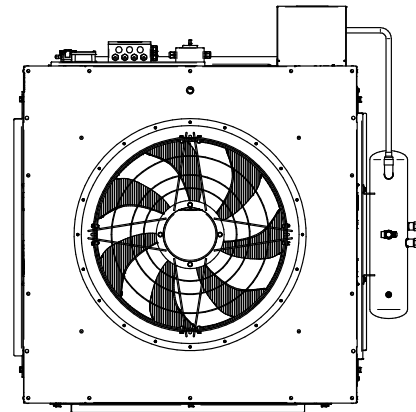
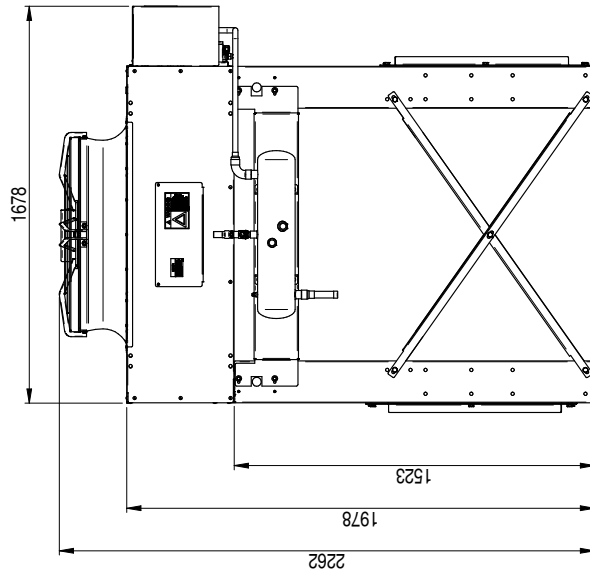

# MCM 080

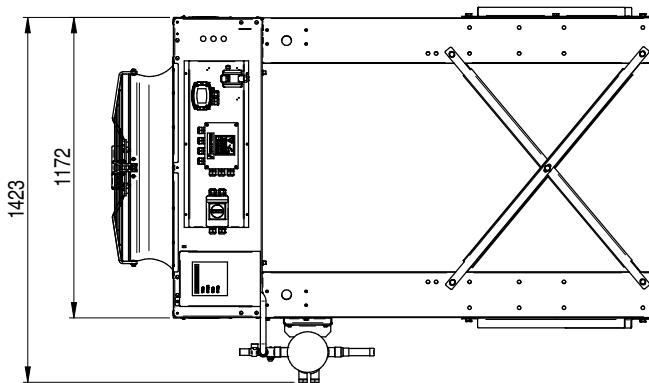
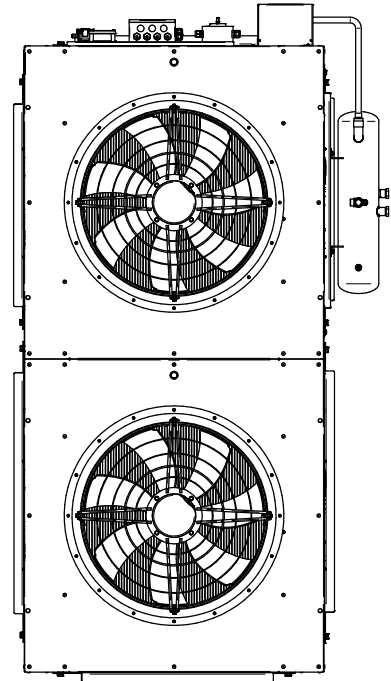
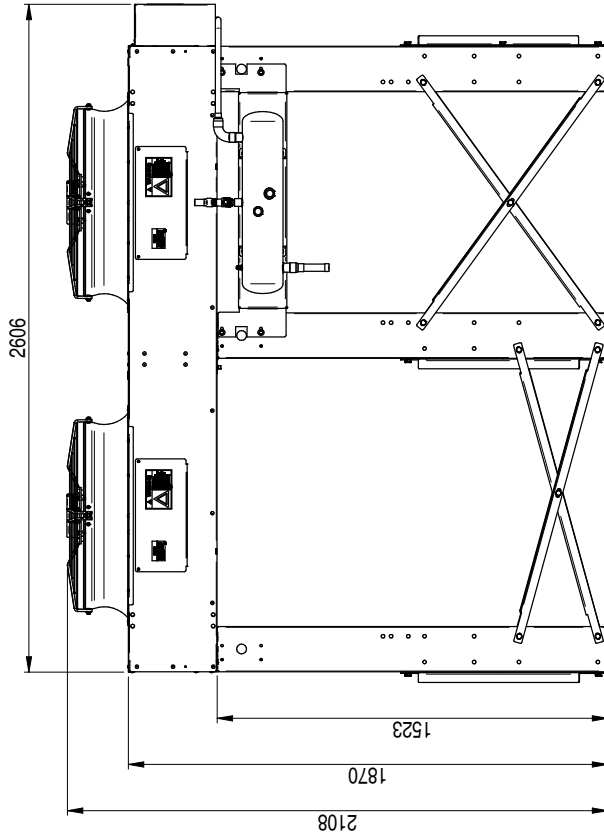

# MCL 110

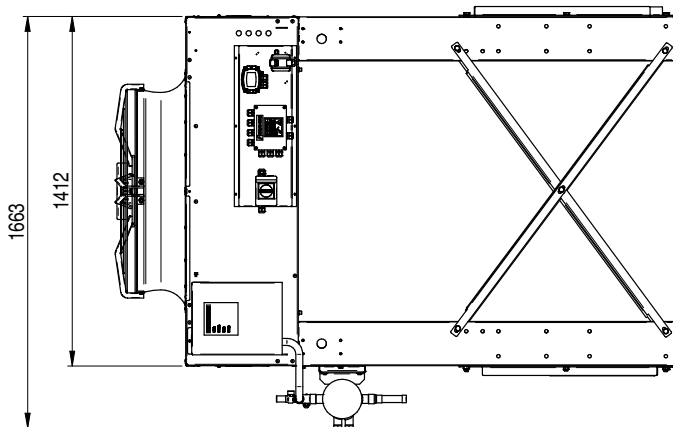
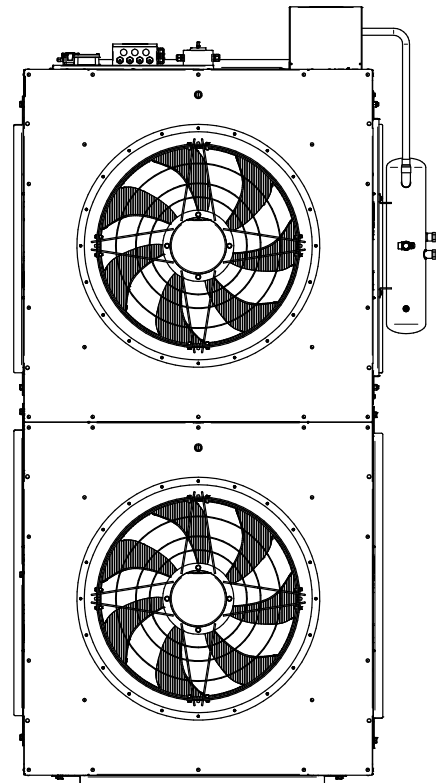
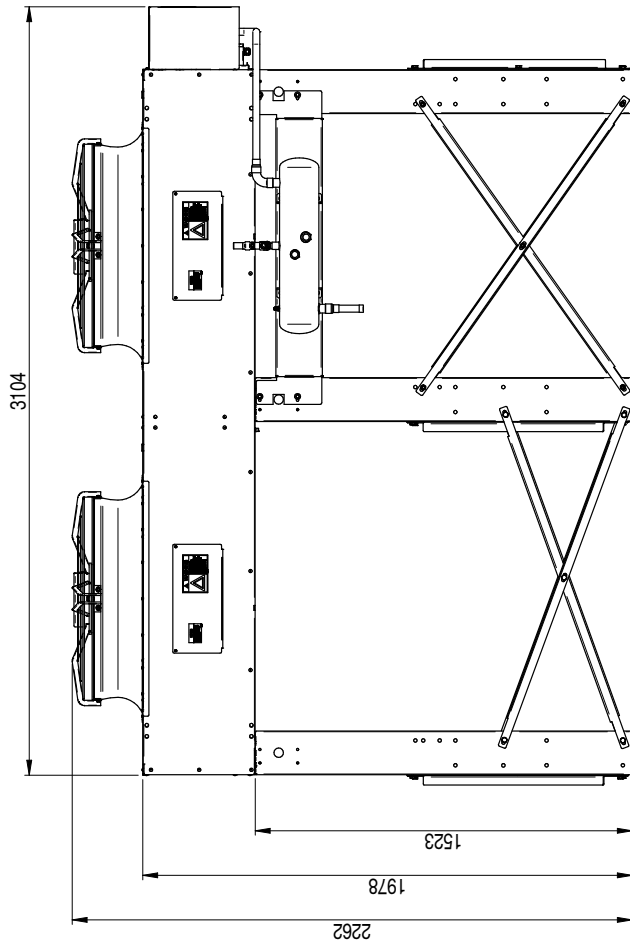

MCL 165

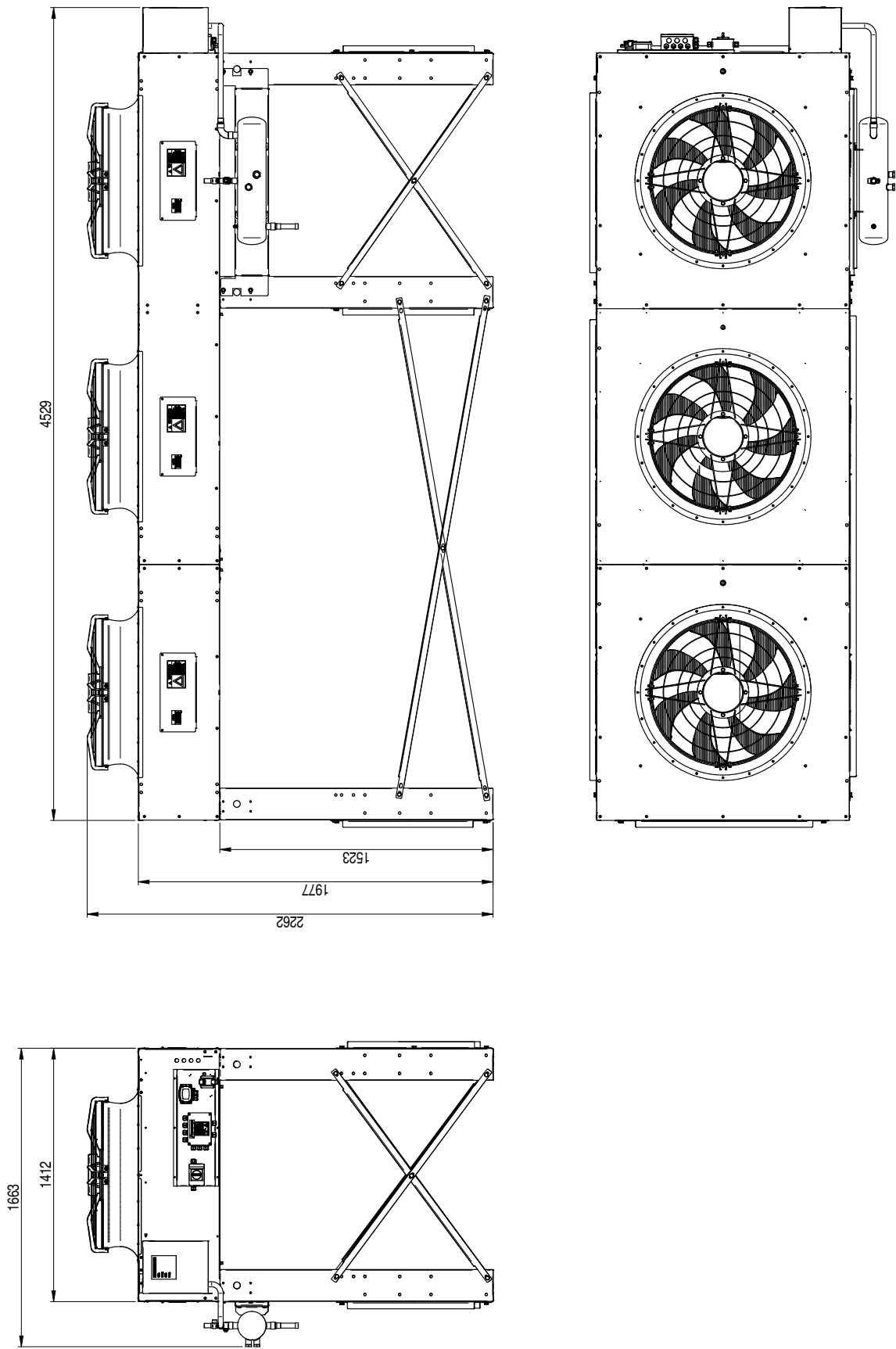

## Packaging Dimensions and Weights

| Model         | Weight (Kg) | Wooden Crate std |        |        |                       |
|---------------|-------------|------------------|--------|--------|-----------------------|
|               |             | L (mm)           | W (mm) | H (mm) | Packaging weight (kg) |
| <b>MCL055</b> | 205         | 1900             | 2066   | 2410   | 57                    |
| <b>MCM080</b> | 260         | 2800             | 1831   | 2280   | 66                    |
| <b>MCL110</b> | 335         | 3300             | 2066   | 2410   | 78                    |
| <b>MCL165</b> | 475         | 4700             | 2066   | 2410   | 160                   |

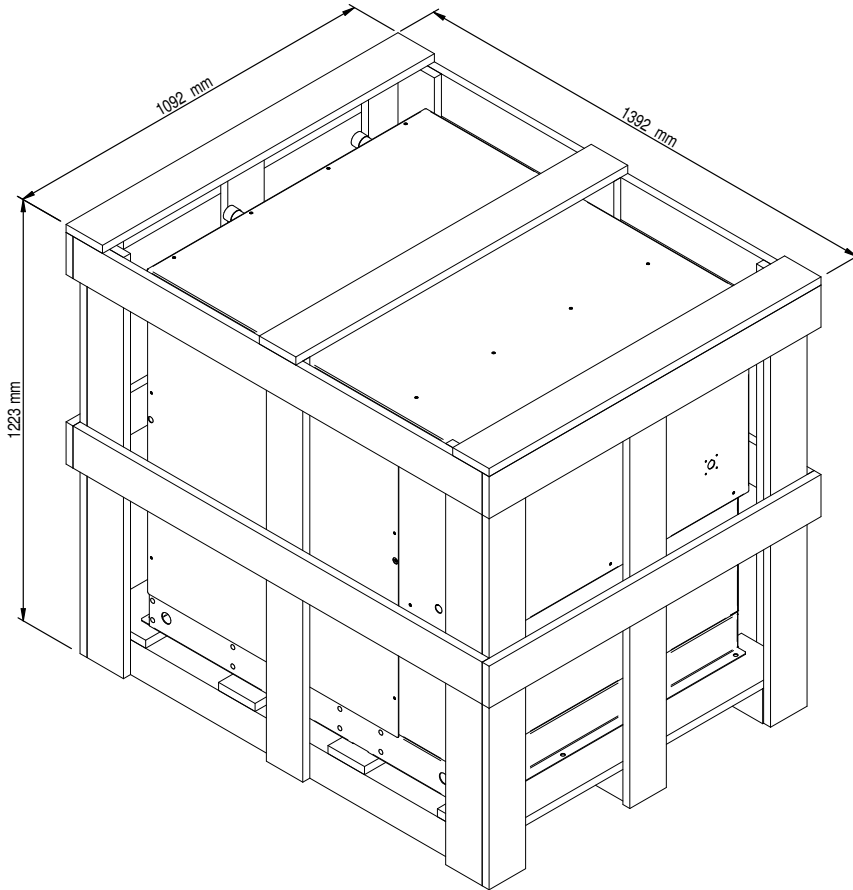

(\*) The total weight of the package will be the sum of the std packaging weight and this value.

# Annex II – Safety Labels

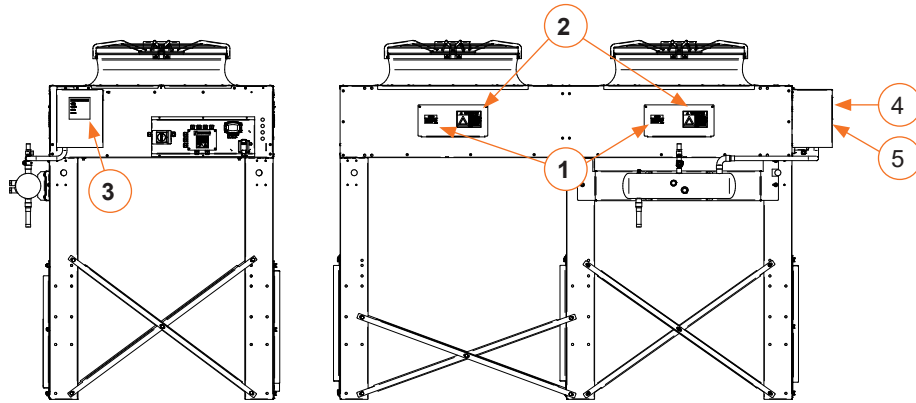

**1**

## NOTICE

Risk of metal dissolving. Can cause coil damage and loss of charge. Do not use acid based cleaner or sodium hydroxide to clean this coil. See user manual for additional information.

**2**

## WARNING

Risk of contact with high-speed rotating blower wheel(s). Can cause injury or death. Disconnect all local and remote electrical power supplies and observe that wheel(s) have stopped rotating before working within.

**3**

### HELIUM/NITROGEN FRIENDLY POLICY

**WARNING :** REFRIGERATION CIRCUIT PRESSURIZED IN FACTORY WITH DRY HELIUM/NITROGEN. FOR THE FOLLOWING OPERATIONS: DISCHARGING HELIUM/NITROGEN, VACUUMING AND CHARGING THE REFRIGERATION CIRCUIT WITH REFRIGERANT, SEE INSTRUCTIONS IN THE ENCLOSED INSTALLATION MANUAL.

**ATTENZIONE :** CIRCUITO FRIGORIFERO PRESSURIZZATO IN FABBRICA CON ELIO/AZOTO SECCO. PER LE OPERAZIONI DI SCARICO ELIO/AZOTO SECCO, VUOTO E CARICA REFRIGERANTE DEL CIRCUITO FRIGORIFERO VEDERE ISTRUZIONI SUL MANUALE DI INSTALLAZIONE.

**ACHTUNG :** DER KÄLTEKREIS WÜRDE IN DER FABRIK MIT HELIUM/TROCKENSTICKSTOFF UNTER DRUCK GESETZT FÜR HELIUM/STICKSTOFFENTLEERUNG, VAKUUM UND KÄLTEKREISFÜLLUNG. BITTE IM HANDBUCH NACHSEHEN.

**ATTENTION :** CIRCUIT DE REFRIGERATION PRESSURISÉ EN USINE AVEC DE HELIUM/L'AZOTE SEC. POUR LES OPERATIONS DE VIDE DE HELIUM/L'AZOTE, VIDE ET REMPLISSAGE DE FRIGORIGÈNE VOIR LES INSTRUCTIONS SUR LA NOTICE D'INSTALLATION.

注意：冷卻系統已注入壓縮乾氦氣，維護工序：排出氦氣，將冷卻系統抽真空及注入所需冷媒，詳情請看附載說明書。

**5**

Vertiv S.r.l.  
Via Leonardo da Vinci, 16018 Sesto Pieve di Sesto - Padova Italy  
Manufactured by VERTIV Slovakia s.r.o. AC Power & Thermal Management, Nowe Mesto Nad Vahou (Slovakia Plant)

**CE**

MODEL  
**MCM080/E/P/M/P/E/A/M/X/E/O/O/O/O/O/O/X/O/O/O/\$2U70302**

ITEM: **MCM080-8040703** NET WEIGHT: **340 kg**

SERIAL N.  
**019106880001**

SALES ORDER N. **87149713** TYPE **ORD\_INTERCO\_HUB\_SK** LINE NUMBER **3**

MANUFACTURING DATE **SEP 2019** **1** OUT OF **1**

SCHEDULE SHIP DATE **16-SEP-2019**

| POS. | DESCRIPTION                                     |
|------|-------------------------------------------------|
| 1    | Label <b>Notice</b> for MC Coil Cleaning        |
| 2    | Label <b>Warning</b> High Speed Blower wheel(s) |
| 3    | Label <b>Warning</b> Helium/Nitrogen            |
| 4    | Label <b>VERTIV™ Liebert® MC</b>                |
| 5    | Dataplate with Serial Number and Model          |





Fabbricante - Manufacturer - Hersteller - Fabricant - Fabricante Fabricante - Tillverkare - Fabrikant - Valmistaja - Produsent Fabrikant  
- Κατασκευαστής - Producent  
Vertiv S.r.l. - Zona Industriale Tognana  
Via Leonardo da Vinci, 16/18 - 35028 Piove di Sacco - Padova (Italy)

Il Fabricante dichiara che questo prodotto è conforme alle direttive Europee:

The Manufacturer hereby declares that this product conforms to the European Union directives:

Der Hersteller erklärt hiermit, dass dieses Produkt den Anforderungen der Europäischen Richtlinien gerecht wird: Le Fabricant déclare que ce produit est conforme aux directives Européennes:

El Fabricante declara que este producto es conforme a las directivas Europeas:

O Fabricante declara que este produto está em conformidade com as directivas Europeias: Tillverkare försäkrar härmed att denna produkt överensstämmer med Europeiska Unions direktiv: De Fabrikant verklaart dat dit produkt conform de Europese richtlijnen is:

Vaimistaja vakuuttaa täten, että tämä tuote täyttää seuraavien EU-direktiivien vaatimukset: Produsent erklærer herved at dette produktet er i samsvar med EU-direktiver:

Fabrikant erklærer herved, at dette produkt opfylder kravene i EU direktiverne:

Ο Κατασκευαστής δηλώνει ότι το παρόν προϊόν είναι κατασκευασμένο σύμφωνα με τις οδηγίες της Ε.Ε.:

**2006/42/EC; 2014/30/EU; 2014/35/EU; 2014/68/EU; 2011/65/EU; EU/2015/863**



**VertivCo.com | Vertiv - EMEA**, via Leonardo Da Vinci 16/18, Zona Industriale Tognana, 35028 Piove di Sacco (PD) Italy, Tel: +39 049 9719 111, Fax: +39 049 5841 257

© 2022 Vertiv Co. All rights reserved. Vertiv, the Vertiv logo and Vertiv Liebert MC are trademarks or registered trademarks of Vertiv Co. All other names and logos referred to are trade names, trademarks or registered trademarks of their respective owners. While every precaution has been taken to ensure accuracy and completeness herein, Vertiv Co. assumes no responsibility, and disclaims all liability, for damages resulting from use of this information or for any errors or omissions. Specifications are subject to change without notice.