



Liebert[®] MC

Air Cooled Remote Condenser with Microchannel Coil

User Manual

English, Cod. 265296, rev. 10.12.2021

Contents

1. Safety	1	8. Installation	15
1.1 Conventions.....	1	8.1 Overview.....	15
1.2 General Instructions.....	1	8.2 Safety Instructions.....	15
1.3 Electric System.....	1	8.3 Location.....	15
1.4 Automatic Restart.....	2	8.4 Space Requirements.....	16
1.5 Personal Protective Equipment.....	2	8.5 Piping.....	17
2. Digit Nomenclature	3	8.6 Electrical Connections.....	18
3. Intended Use	4	9. Unit Controller	22
3.1 Functional Limits.....	4	9.1 Premium board.....	22
3.2 Operating environment.....	4	9.2 Basic board.....	35
3.3 Space Limits.....	5	9.3 Controlled by Indoor Unit.....	38
4. Test and Reference Norms	6	10. Maintenance	41
5. Description	7	10.1 Safety Instructions.....	41
5.1 Main Components.....	7	10.2 Safety Labels.....	42
5.2 Electric System.....	7	10.3 Refrigeration System.....	42
5.3 Mechanical Specifications.....	8	10.4 Heat Exchanger.....	42
5.4 Efficiency Control System.....	8	10.5 Fans.....	43
6. Technical Data	10	10.6 Controller.....	44
6.1 Technical Data and Performances.....	10	11. Troubleshooting	45
6.2 Coil Dimensions.....	11	12. Dismantling the unit	46
6.3 Installation Dimensions.....	11	12.1 Safety Instructions.....	46
7. Handling	12	12.2 Operations.....	47
7.1 Safety Instructions.....	12	13. Regulation (EU) no. 517/2014 (F-gas)	48
7.2 Inspection.....	12	13.1 Introduction.....	48
7.3 Storage.....	12	13.2 Normative References.....	48
7.4 Transport - with Package.....	13	13.3 Fluorinated Greenhouse Gases.....	48
7.5 Unpacking.....	13	13.4 Operators.....	49
7.6 Transport - without Package.....	14	13.5 Leakage Detection.....	49
		13.6 Labelling.....	49
		13.7 Record Keeping.....	50

Annexes

Annex I – Application Firmware Update	51
Annex II – Dimensions and Weight	52
Annex III – Safety Labels	62

Documents supplied with the machine

- User Manual (this document)
- Electrical Diagrams
- Instruction Leaflet for Transport and Handling (on the packaging)
- Labels with Gravity Center (on the packaging)
- Warranty Certificate
- Test Certificate
- Declaration of Conformity

Onboard Label

Please refer to the label placed on the unit for the relevant operating data.

If you need assistance or spare parts, please find the model identification and the serial number on the label.



NOTICE

The data in the manual are referred to standard conditions and can be modified without any advance notice.
The data relevant to the supplied unit are filled in the inboard label (see below an empty facsimile).



VERTIV™

CE

1

MODEL 2
 SERIAL N. 3
 VOLTAGE-PHASE-FREQUENCY 4

COMPRESSOR		
FLA	LRA	QT.
COMPRESSOR		
FLA	LRA	QT.
FAN MOTOR		
FLA 5	LRA 6	QT. 7
FAN MOTOR		
FLA	LRA	QT.
EL. HEATER		
A	STAGES	
HUMIDIFIER		
A	STEAM OUTPUT	kg/h
TOTAL FLA AC	TOTAL FLA DC	Ipk KA
A 8	A	Icw 9 KA

REFRIGERANT TYPE

CIRCUIT 1 REFRIGERANT CHARGE		CIRCUIT 2 REFRIGERANT CHARGE	
ON FACTORY	ON SITE	ON FACTORY	ON SITE
	kg		kg

MAX ALLOWABLE PRESSURE

HP SIDE(PS)	bar	LP SIDE(PS)	bar
-------------	-----	-------------	-----

HIGH PRESS. SWITCH-MANUAL

SET	bar	RESET	bar
-----	-----	-------	-----

LOW PRESSURE SWITCH

SET	bar	RESET	bar
-----	-----	-------	-----

OPERATING AIR TEMPERATURE

min 10	°C	max	11 °C
--	----	-----	---

OPERATING AIR HUMIDITY

min 12	%	max	13 %
--	---	-----	--

CIRCUIT MAX. PRESSURE

bar 14

NET WEIGHT

kg 15

MANUFACTURING DATE 16

Pos.	Description
01	Manufacturing plant
02	Model
03	Serial number
04	Voltage/Phase/Frequency
05	Condenser Fan Motor Full Load Ampere [A]
06	Condenser Fan Motor Locked Rotor Ampere [A]
07	Condenser Fan Motor Quantity
08	Unit Total Full Load Ampere AC [A]
09	Rated Short-Time Current [kA]
10	Min. Ambient Operation Temperature [°C]
11	Max. Ambient Operation Temperature [°C]
12	Min. Ambient Operation Humidity [%]
13	Max. Ambient Operation Humidity [%]
14	Max . Refrigerant Circuit Pressure [bar]
15	Unit Net Weight [kg]
16	Manufacturing Date

1. Safety

This chapter gives general safety instructions.

Additional safety warnings, for specific operations, are given in the rest of the manual.

1.1 Conventions



DANGER - Indicates a hazardous situation which, if not avoided, **will** result in death or serious injury.

WARNING - Indicates a hazardous situation which, if not avoided, **could** result in death or serious injury.

CAUTION - Indicates a hazardous situation which, if not avoided, **may** result in minor or moderate injury.



NOTICE

Indicates a property damage message

1.2 General Instructions

Intended readers	This User Manual is intended for transport, installation and maintenance personnel. The end user can only switch the unit ON and OFF
Authorized personnel	The operations described in this manual must be made by technical staff, expressly authorized in compliance with the regulations in force at the installation site.
Read this manual	Carefully read the manual before performing any operation on the unit.
Keep this manual	Keep the manual during the complete life-span of the unit. If you move or sell the unit, transfer the manual together with the unit.
Intended use	Exclusively employ the unit for the purpose it has been designed (see 3. <i>Intended Use</i>). The improper use of the unit exonerates the manufacturer of any responsibility.
Do not modify the unit	Do not modify the unit in any way, including the control system and the software. Any modification to the unit exonerates the manufacturer of any responsibility.
Warning labels	Pay attention to the warning labels on the unit. See <i>Annex III – Safety Labels</i> for the mapping of the safety labels placed on the unit.

1.3 Electric System



WARNING

Unit contains potentially lethal voltage in some circuits.

Risk of arc flash and electric shock.

Can cause injury or death.

- Open all local and remote unit electric power disconnect switches, verify with a voltmeter that power is **OFF** and wear protective equipment per local standard before working within the electric control enclosure.



WARNING

The electric connection enclosures, the fan speed control and the EC fan enclosures can retain a stored high-voltage electrical charge for up to **10** minutes.

Risk of electric shock.

Can cause serious injury or death.

Before working within the unit electric connection enclosures or working within the fan speed control and the EC fan enclosures proceed as follows:

- open all local and remote unit electric power disconnect switches
- wait **10** minutes
- verify with a voltmeter that power is **OFF**

Only properly trained and qualified personnel may perform repair, maintenance and cleaning.

1.4 Automatic Restart



WARNING

Fan blades can automatically start rotating without warning at any time during a cooling cycle or after power is restored after a power failure.

Risk of contact with high-speed, rotating fan blades.

Can cause serious personal injury or death.

Before working within the unit cabinet, removing the fan guards or servicing the fan speed control, fan blades or EC fan motors proceed as follows:

- open all local and remote electric power supply disconnect switches
- wait **10** minutes
- verify with a voltmeter that power is **OFF**



WARNING

This unit operates and restarts automatically.

The fans may suddenly start blowing out a strong air flow, which may carry particles and small objects from inside the unit.

Can cause serious personal injury.

- Wear eyes protection when you need to get close to the unit while it is operating.
- Turn the main switch to **OFF** to disconnect the unit from the power supply before any operation on the unit.

1.5 Personal Protective Equipment

As a general rule, always wear the following **PPE** (Personal Protective Equipment):



CAUTION

The microchannel condenser is made of plates and fins, which may have sharp edges and blurs. Always wear cut resistant gloves when operating on the condenser.



CAUTION

Components at high temperature (condenser inlet piping at about 120°C).

Always wear temperature resistant gloves when operating on the condenser.

2. Digit Nomenclature

The unit is fully defined by twenty five digits.

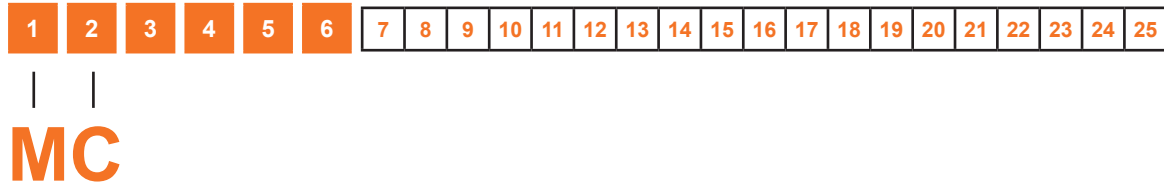

Digit	Feature	Value	Description
1 2	Unit Family:	MC	Micro Channel
3	Platform Size:	S M L	Small Medium Large
4 5 6	Heat Rejection Capacity "kW":		
7	Control Fan Type:	E F M	Premium and EC Fan Control Basic and AC Fan Control Controlled by Indoor Unit
8	Refrigerant Circuit:	1 2 P	Single Refrigerant Circuit, R410A Dual Refrigerant Circuit, R410A Single Circuit Econo-phase
9	Power Supply:	2 M H K	230V / 1ph / 50Hz 400V / 3ph / 50Hz 200 - 277V / 1ph / 50 - 60Hz 380 - 480V / 3ph / 50 - 60Hz
10	Packaging	C S	Cratting – Non-Stackable (vertical Airflow orientation) Seaworthy packaging
11	Coil Coating	0 E	None E-coat (Epoxy)
12	Panel Material	A	Bright Aluminium
13	Connection Pipe	0 M	Imperial Metric
14	Legs Included	X	Legs for horizontal and vertical flow
15	Agency Certification	E	CE agency certification
16	Sound Level	0	Standard Sound
17	Low temperature configuration	0	None
18	Fusible Plug Kit	0	None
19	Sensors and Probe	0 1	None Air temperature Probe
20 - 21	Free		
22	Special Feature	A X	No SFA With SFA
23 - 25	Free		

3. Intended Use

The **Liebert® MC** microchannel heat exchanger is a range of remote air-cooled condensers designed to be coupled with **Liebert®** air conditioning units.

Liebert® MC Condensers cover a complete range of nominal heat rejection capacities, from 28 to 165 kW.



The **Liebert® MC** condensers are equipped either with EC axial fans or AC axial fans.

The condenser is classified into two types: single or dual system. The single system has a set of discharge/liquid pipe to match the single refrigeration system of indoor unit. The dual system has two sets of discharge/liquid pipes to match the two separate refrigeration systems of indoor unit.

The **MC** condensers are suitable for both vertical and horizontal air flow installation.

It can be equipped with a fan controller (stand alone) or it can be without controls (managed by the control of the indoor unit via Modbus protocol). In this case, the condenser may require a fan setting during installation.

3.1 Functional Limits

Refrigerant	<p>This unit is designed for use with R410 A (group 2, not dangerous according to PED Directive).</p> <div style="display: flex; align-items: center;">  <div> <p>WARNING</p> <p>Risk of components failure or breakage. Do not use other refrigerants. Contact the manufacturer in case of doubt.</p> </div> </div>
Performance	<p>Nominal heat rejection capacity: See <i>6.0 Technical Data</i> MAX working pressure: 45 barg</p>
Electrical system requirements	<p>Voltage and Frequency Limits:</p> <p>MC with EC Fan 1Ph AC supply 200V-277V ± 10% 50-60Hz 0,99 to 1,01 of nominal frequency continuously 0,98 to 1,02 short time</p> <p>MC with EC Fan 3Ph AC supply 380V-480V ± 10% 50-60Hz 0,99 to 1,01 of nominal frequency continuously 0,98 to 1,02 short time</p> <p>Protection level: Electrical control box: IP55, Unit body: IPX5</p> <div style="display: flex; align-items: center;">  <div> <p>WARNING</p> <p>Risk of components failure or breakage. Do not use different voltage. Contact the manufacturer in case of doubt.</p> </div> </div>

3.2 Operating environment

This unit is designed for outdoor installation, with the following ambient conditions:

Outdoor ambient temperature	<p>-30 °C – +48 °C with “Controlled by Indoor Unit” -30 °C – +46 °C with Basic and Premium Board</p> <p>For installation with ambient temperature below -20°C be sure the plant has been arranged with Low Temp kit and other necessary arrangement as per Vertiv™ specification.</p>
Outdoor ambient humidity	5% – 95%
Ambient	<p>Do not use in explosive, acid or anyway aggressive atmosphere.</p> <p>In case of installation near the sea or other particularly atmosphere conditions consider to order the Epoxy coating.</p>
Altitude	<p>≤1000 m Derating is required if the altitude exceeds 1000 m</p>

3.3 Space Limits

Overall unit dimensions

Provide enough free space to place the unit. See *Annex II – Dimensions and Weight*

Keep a free space around the unit as explained in *8.4 Space Requirements*.

Clearance



NOTICE

The unit does not operate correctly if placed too close to walls or other obstacles.

4. Test and Reference Norms

Liebert® MC units are designed, manufactured and tested according to the following directives and standards:

EU Directives	<ul style="list-style-type: none">- Machine Directive 2006/42/CE- PED 2014/68/EU- LVD 2014/35/EU- EMC 2014/30/EU- RoHS II Directive 2011/65/EU- RoHS III Directive EU/2015/863
Electrical Board	<ul style="list-style-type: none">- EN 60204-1- CEI 20-22 II- IEC 332-3 cat. A.
Electro-Magnetic Compability (EMC)	<ul style="list-style-type: none">- EN 61000-6-2:2005 Electromagnetic compatibility (EMC) - Part 6-2: Generic standards - Immunity for industrial environments- EN 61000-6-3:2011 Electromagnetic compatibility (EMC) - Part 6-3: Generic standards - Emission standard for residential, commercial and light-industrial environments
Performances	<ul style="list-style-type: none">- Heat rejection capacities tests (with R410A): UNI EN 327- Sound pressure levels (referred to 5m far from the unit): EN13487
CE Marking and Conformity Declaration	<p>The units are marked “CE”.</p> <p>Each unit is supplied complete with individual test certificate and a certificate of conformity to the European Union Directives.</p> <p>See also the last page.</p>

5. Description

5.1 Main Components

View from electric box side (front side)

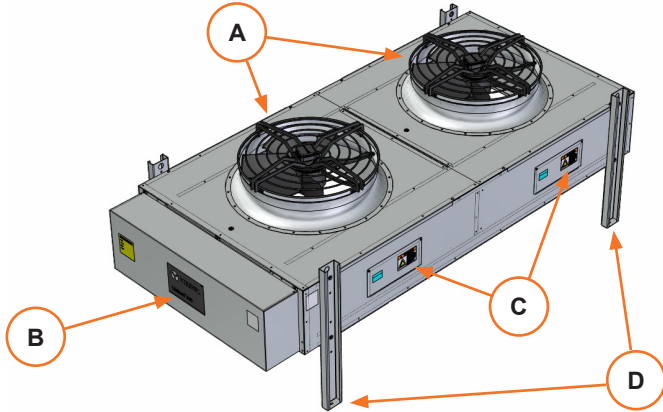

- A Fans
- B Electric box
- C Windows for inspection and cleaning
- D Supporting structure

5.2 Electric System

5.2.1 Electric Box and Main Switch

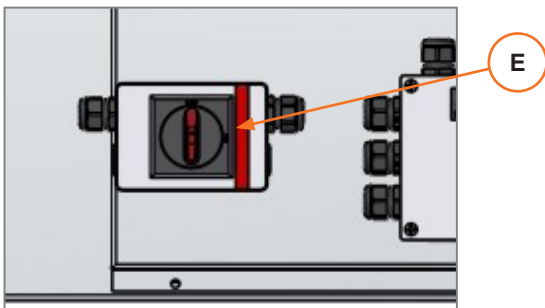

The figure shows the electric box.
 The main switch [E] is a disconnecting switch and cuts off the electric power supply to the unit.
 The controller, connected to the main unit, starts / stops the unit operation.

5.2.2 Electrical Connections Basic and Premium board

The following figure shows the electrical service entrances into unit:

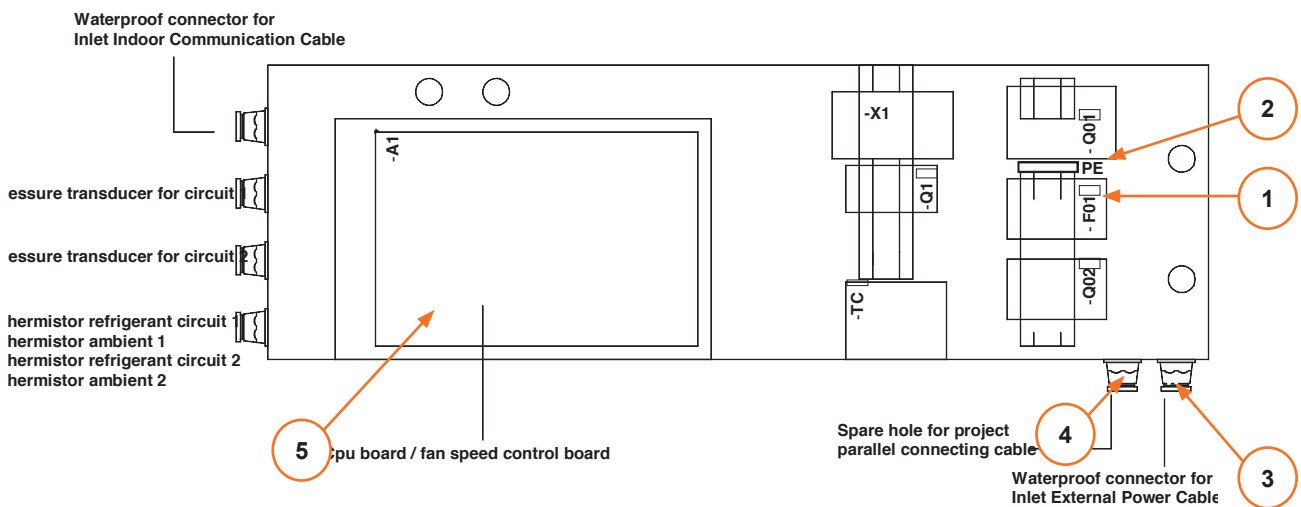

Ref.	Function	Description
1	Three-phase electrical service	Terminals are on the right side of the disconnect switch. The three-phase cable is not provided by Vertiv™.
2	Earth ground	Field lug terminal for earth ground connection.
3	Primary high-voltage entrance	Two M20 cable gland at the bottom of the enclosure.
4	Primary low voltage entrance	One M20 cable gland at the bottom of the enclosure. This is free for customer low voltage wiring.
5	Premium control board	See 9.1 Premium board
6	Basic control board	Allow regulation of AC fans See 9.2 Basic board

5.3 Mechanical Specifications

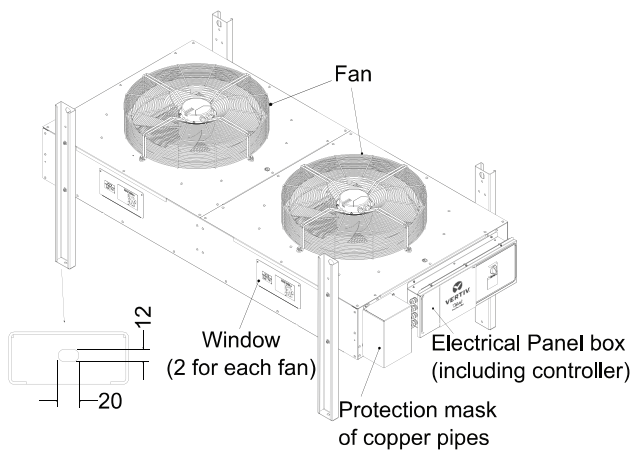

The cabinet and legs are made of aluminum. In the multi-fan models the air flow is maintained separated. The protection mask of copper pipe is used to protect the inlet and outlet copper pipes.

The window is used to clear the heat exchanger periodically. The attaching legs are the same for horizontal and vertical installation.

Fan

The axial fan motor is built with external rotor. The position and appearance of the fan are shown in the figures of this page.

Controller

The Basic/Premium Board regulates the fan speed according to the pressure and temperature collected by the pressure transducer and temperature sensor. It is located inside the electrical control box, as shown in the figures of this page.

A communication board is used as controller. Instead with Control by Indoor Unit is the main unit control that manages the pressure.

Pressure transducer (not available when controlled by indoor unit)

The pressure transducer is inside the protection mask of copper pipe. It is installed at the outlet of the condenser and used to collect the outlet pressure of the condenser. Its position is shown in the figures of this page.

Temperature sensor

Only premium version condenser has temperature sensors as standard. One is installed at the outlet of the condenser inside the protection mask of copper pipe. The other is installed on the end plate under the electrical control box. They are used to collect the outlet temperature of the condenser and ambient temperature respectively. The option “controlled by indoor unit”, allows to install a temperature probe placed on the end plate under the control box to collect the ambient temperature.

5.4 Efficiency Control System

EC fans

The EC fan is an integral assembly of an electronically commutated motor, quiet fan blade assembly and finger/hail guard.

**Premium
Efficiency
Control/EC Fan**

Premium Efficiency Controls and EC fans are matched to provide superior system energy efficiency. The premium control board allows CANbus communication with the indoor unit's Liebert® iCOM™ control. This communication feature provides compressor run signals, condenser operating mode changes, condenser alarm monitoring, simplified system charging procedures and outdoor ambient temperature monitoring. The EC fan is an integral assembly of an electronically commutated motor, quiet fan blade assembly and finger/hail guard. The fans are controlled by the premium control board using pressure transducer signals from the refrigerant circuit and factory programming to control the refrigerant head pressure. The premium control board uses inputs from the indoor unit, condenser refrigerant pressures and temperatures and ambient temperatures to modulate the EC fan motor speed from 0 to 100% RPM, maintaining refrigerant head pressure setpoints. PCB, EC fan(s) and transducer(s) are factory-wired. Multiple fan dual refrigeration circuit condensers adjust fan speed independently to match each circuit's head pressure conditions. Multiple fan single refrigeration circuit condensers adjust all fans to the same RPM to maintain head pressure.

**Control by
Indoor Unit/EC
Fan**

The condenser is directly connected to the indoor unit via Modbus communication. The unit is able to optimize the system by managing everything through a single control, then combines the advantages of EC fans with system management. It's possible to install an external temperature probe in the condenser in order to have a control on the external conditions. The system allows to adjust the system pressure (head pressure setpoint) like the Premium Board. The pressure transducer is present and wired inside the indoor unit.

6. Technical Data and Performance

6.1 Technical Data and Performances

Model		Power supply	Total Heat Rejection * R410A	Air Volume	Noise Level **	Power Input	Current Absorption	FLA
		[V/Ph/Hz]	[kW]	[m3/h]	[dB(A) @5m]	[kW]	[A]	[A]
MCS028	Basic Std Fan AC	230/1/50	29.60	7452	50.10	0,47	1,73	2.30
MCM035		230/1/50	34.50	8000	50.10	0,47	1,73	2.30
MCM040		230/1/50	44,78	10600	52.00	0,78	3,75	4.40
MCL055		400/3/50	58.60	16250	53.50	1.60	3.60	4.40
MCM070		230/1/50	69.00	16000	53.10	2x0,94	3,46	2X4.4
MCM080		230/1/50	89,56	21200	55.00	2x1,55	7.50	2X4.4
MCL110		400/3/50	117.20	32500	57.00	2x3.20	7.20	2x1.6
MCM160		230/1/50	179,12	42400	60.00	4x3.10	15.00	4X4.4
MCL165		400/3/50	175.80	48750	66.80	3x4.80	10.80	3x1.6
MCS028	Premium EC Fan	230/1/50	32,96	8831	49.80	0.85	0.99	4.3
MCM040		400/3/50	41,97	11264	54.00	0.81	1.23	1.5
MCL055		400/3/50	59,55	15451	62.00	2.1	1.72	3.5
MCM080		400/3/50	83,94	22528	57.00	2x0.81	2.46	3.0
MCL110		400/3/50	112.00	30902	65.00	2x2.1	3.96	7.0
MCM160		400/3/50	168.00	45056	60.00	4x0.81	4.92	6.0
MCL165		400/3/50	179.00	46353	66.80	3x2.1	2.76	10.5
MCS028	Controlled by Indoor Unit	200-277/1/50-60	37,8	10244	53	0,69	3	4,3
MCM040		400/3/50	43,2	11856	56	0,72	1,19	1,3
MCM080		400/3/50	86,2	23700	59	1,45	2,39	2,7
MCL055		400/3/50	65,9	18860	61,1	1,78	2,75	4,6
MCL110		400/3/50	131,9	37720	64,1	3,53	5,45	9,2
MCL165		400/3/50	197,7	56580	65,9	5,31	8,37	13,8
MCM040	Controlled by Indoor Unit	380/3/60	43,2	11856	56	0,72	1,25	1,4
MCL055		380/3/60	65,9	18860	61,1	1,77	2,86	4,8
MCM080		380/3/60	86,2	23700	59	1,48	2,46	2,8
MCL110		380/3/60	131,9	37720	64,1	3,53	5,72	9,6
MCL165		380/3/60	197,7	56580	65,9	5,31	9,75	14,4
MCM040	Controlled by Indoor Unit	460/3/60	43,2	11856	56	0,72	1,04	1,2
MCL055		460/3/60	65,9	18860	61,1	1,77	2,37	4,1
MCM080		460/3/60	86,2	23700	59	1,48	2,46	2,8
MCL110		460/3/60	131,9	37720	64,1	3,53	4,74	8,1
MCL165		460/3/60	197,7	56580	65,9	5,31	7,95	12,2

Total Heat Rejection* @ R410A; Delta (Tsaturated condensing - Tair inlet)=15K; Tcoil air inlet = 35°C; Liquid subcooling = 3K; Installation height = 0m above the sea level; clean exchange surfaces
 Noise Level ** Sound Pressure Level measured with horizontal installation in the same operative conditions, referred to 5 m far from the unit, in a free field over a reflecting plane (according to EN13847).

6.2 Coil Dimensions

Platform	Model	Fan	Circuits	Coil Volume	Weight
		Nr.	Nr	[dm ³]	(kg)
Small	MCS028	1	1	2.8	70
Medium	MCM035	1	1	3.5	3.5
	MCM040	1	1	3.5	105
	MCM070	2	1	3.5	3.5
	MCM080	2	1	7.0	200
	MCM080	2	2	7.0	200
	MCM160	4	2	14.0	380
Large	MCL055	1	1	5.0	156
	MCL110	2	1	11.6	273
	MCL110	2	2	11.4	273
	MCL165	3	1	19.4	404

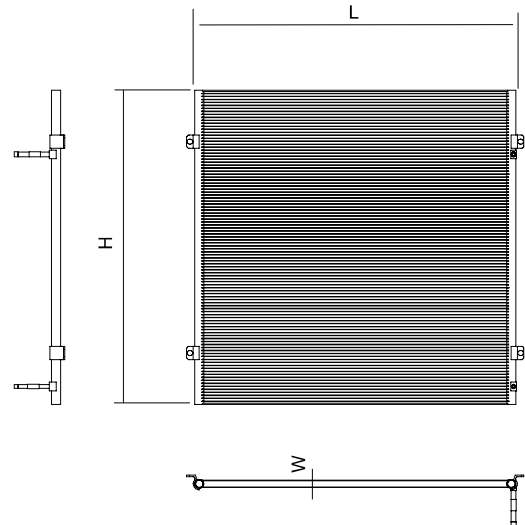

6.3 Installation Dimensions

6.3.1 Base dimension for horizontal installation

Model	Dimension (LxWxH)		
	L [mm]	W [mm]	H [mm]
MCS028	1283	1180	1047
MCM035	1381	1269	1043
MCM040	1381	1269	1063
MCL055	1676	1509	1196
MCM070	2602	1269	1043
MCM080	2602	1269	1063
MCL110	3102	1509	1196
MCM160	5045	1269	1063
MCL165	4527	1509	1196

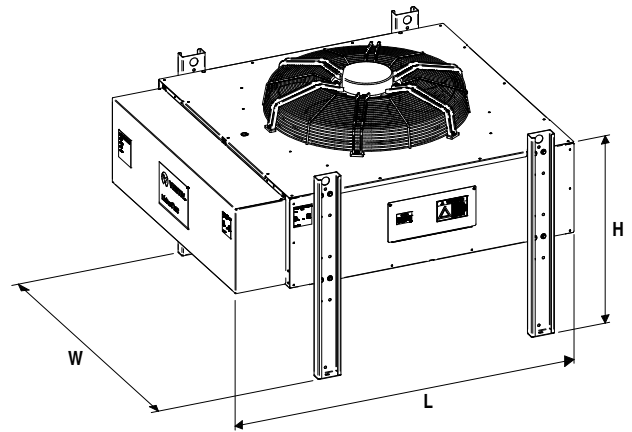

6.3.2 Base dimension for vertical installation

Model	Dimension (L1xWxW1)		
	L1 [mm]	W [mm]	W1 [mm]
MCS028	1283	585	346
MCM035	1381	585	346
MCM040	1381	605	346
MCL055	1676	740	454
MCM070	2654	585	346
MCM080	2654	605	346
MCL110	3102	740	454
MCM160	5045	605	346
MCL165	4527	740	454

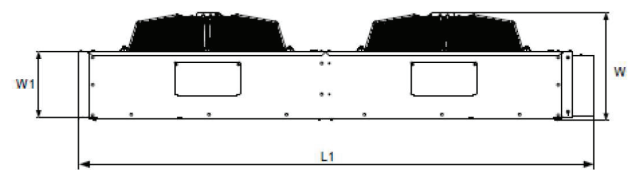

7. Handling

7.1 Safety Instructions



WARNING

Improper handling can cause injury or death.

Only authorized personnel is allowed to move, lift, remove packaging from or prepare the unit for installation.

The authorized personnel must be properly trained and qualified, wear appropriate personal protective equipment and use adequate moving equipment (cranes, forklift, etc.).



WARNING

Make sure to use transport and lifting equipment rated for the unit dimensions and weight.

See *Annex II – Dimensions and Weight*



WARNING

Never walk or stay below a suspended load.



CAUTION

Sharp edges, splinters and exposed fasteners.

Wear protective gloves before operating on the unit.



NOTICE

Improper handling can cause product damage.

7.2 Inspection

- After receiving the product, check the accessories against the packing list.
- If any parts are found missing or damaged, please report to the carrier immediately.
- If you find any damage, please report to the carrier and to the local distributor too.

7.3 Storage

You may keep the unit in a storehouse with the following ambient conditions:

Item	Requirement
Storage environment	Clean (no dust), well-ventilated indoor environment.
Ambient temperature	-40°C – +70°C
Ambient humidity	5%RH – 85%RH
Storage time	The total storage time should not exceed six months. Otherwise, the performance needs to be re-calibrated.



NOTICE

These requirements are valid only for the unit without refrigerant charge.

If the microchannel condenser is assembled with the main unit and the whole system is charged with refrigerant, and then put in a storehouse, there is a risk of overpressure in a lower ambient temperature range.

Please refer to the main unit manuals for allowed ambient temperatures with refrigerant charge.

7.4 Transport - with Package

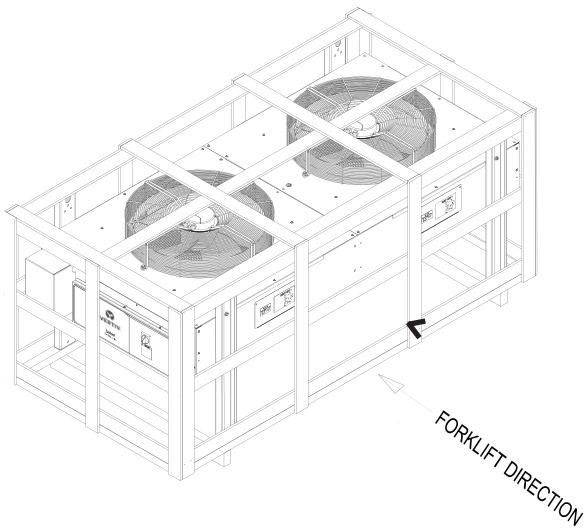

Use mechanical transport equipment such as a forklift or a crane when unloading or moving the packed unit to the installation site.

When a forklift is used to unload and move the packed unit:

- Insert the tines of the forklift following the direction shown in the figure.

7.5 Unpacking

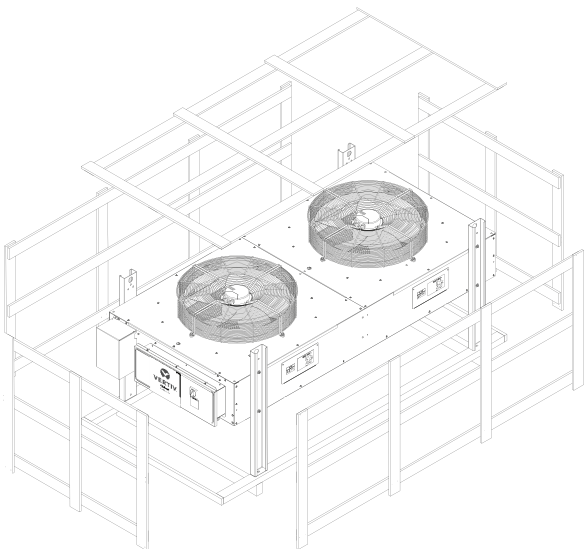

- Remove the exterior packaging material from around the unit.

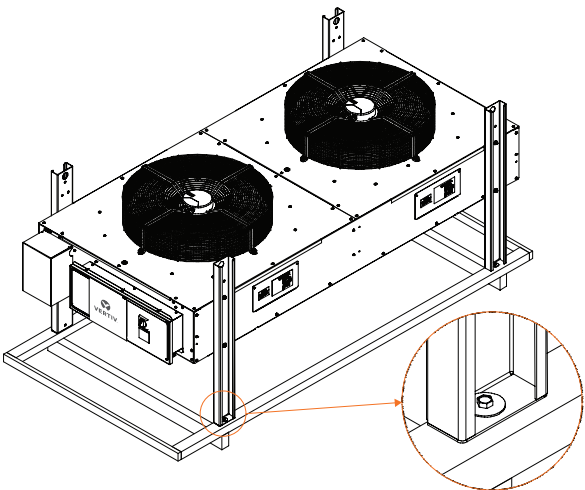

- Remove the bolts securing the unit to the pallet.

7.6 Transport - without Package

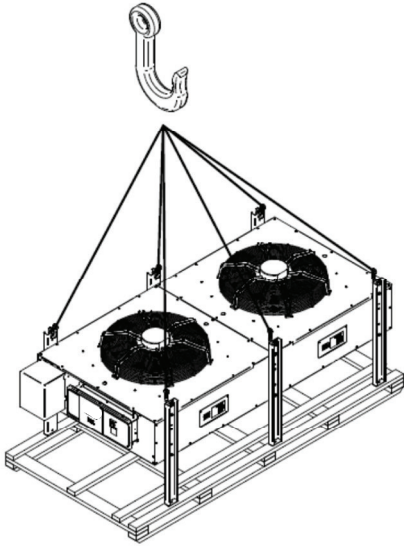

Use a crane to move condensers.

- Fix the slings by lading through the slot at the condenser's legs.
- Make sure to use slings rated for the unit weight.

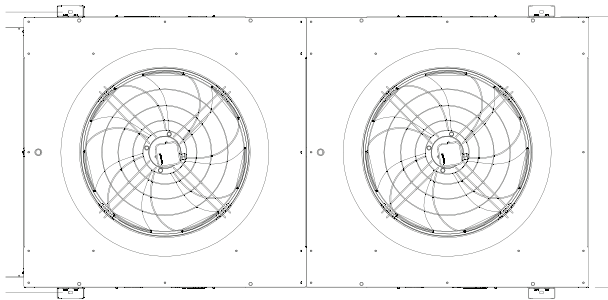

8. Installation

8.1 Overview

The unit is delivered fully assembled at the factory, including all the internal wiring.

The following operations must be done at the installation site:

Operation	See ...
Position the unit at the final location and fix it on the floor or the supporting structure	8.3 Location 8.4 Space Requirements
Connect the piping to the main unit	8.5 Piping
Connect the main switch to the electric power supply	8.6 Electrical Connections
Connect the Premium Controller “controlled by Indoor Unit” to the main unit (low voltage connection)	9.1 Premium Board
If necessary, set up the parameters of the control system	9.3 Control by Indoor Unit

8.2 Safety Instructions



WARNING

Only authorized personnel is allowed to do installation operations.

The authorized personnel must be properly trained and qualified, wear appropriate personal protective equipment and use adequate tools.



CAUTION

Sharp edges, splinters and exposed fasteners.

Wear protective gloves before operating on the unit.



NOTICE

Improper handling can cause product damage.

8.3 Location

Condensers should be installed in a location offering maximum security and access for maintenance.

The service area must be respected.

Avoid areas prone to heavy snow or ice accumulations.

The installation site must guarantee a sufficient dispersion of the air to allow operation in even the severest conditions. **Vertiv™** recommends that condensers to be installed in an area with clean air, away from loose dirt and foreign matter that might clog the coil.

For roof installation, mount the condenser on suitable curbs or other supports in accordance with local rules.

Follow the installation arrows on the condenser for the installation.

Horizontal installation (vertical air flow):

- In order to allow sufficient air through the unit and space for any eventual maintenance, The Service Area should be left free of obstructions.
- With vertical air flow installation, a free area of at least 4 m above the condenser has to be guarantee for a correct air circulation with the aim to avoid shot-cut from discharge to suction air side of condenser.

Vertical installation (horizontal air flow):

- Always position the condenser so that the copper pipes are at the bottom.
- In order to allow sufficient air through the unit and space for any eventual maintenance, The Service Area should be left free of obstructions.

- During vertical installation, the top condenser must be installed on a rack and the cushion pads should be used between the condenser and the rack for damping. It is prohibited to stack two condensers directly through bolt connection.
- If the condenser is installed on stilts vertically, you must ensure that the support has sufficient strength. For the single-fan condenser, at least two supports are required; for the double-fan condenser, at least three supports are required. Each support area cannot be less than 345mm x 80mm.

8.4 Space Requirements

The condenser needs sufficient installation and service space around the installation place. The detailed space requirements are shown in Figures below



NOTICE

The unit does not operate correctly if placed too close to walls or other obstacles.

8.4.1 Horizontal Installation

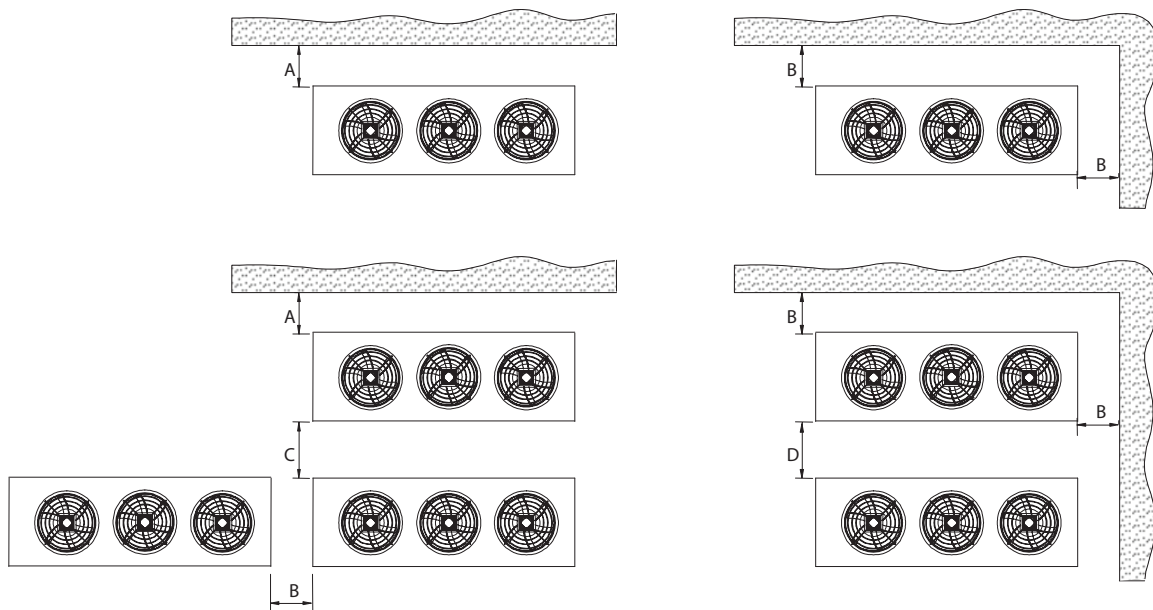

8.4.2 Vertical Installation

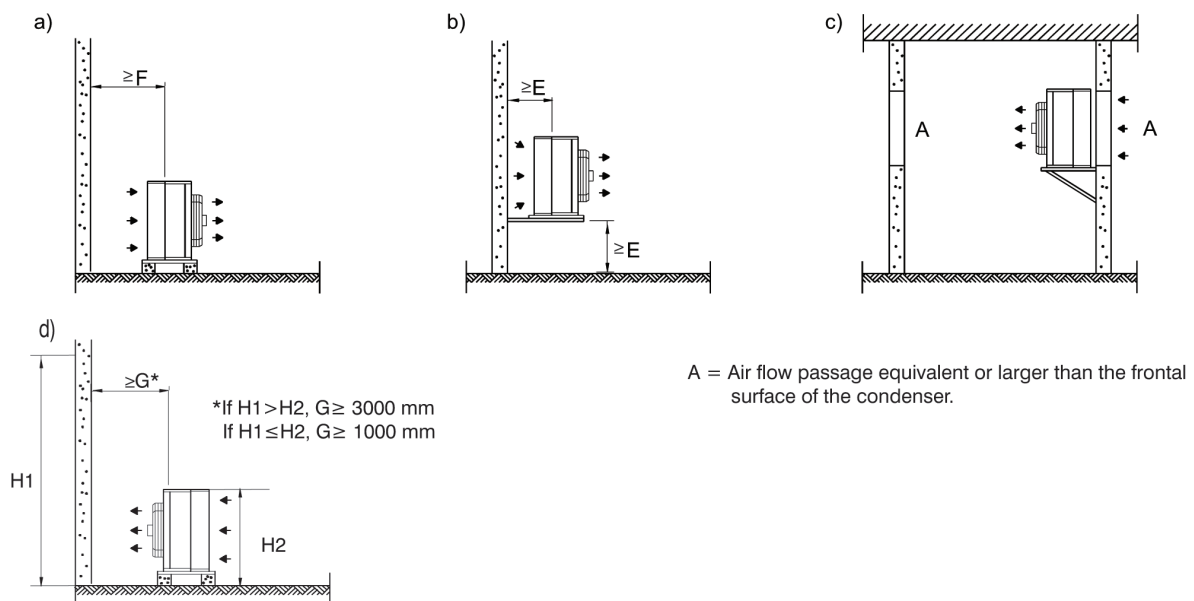

A = Air flow passage equivalent or larger than the frontal surface of the condenser.

Model	Horizontal installation				Vertical installation	
	A	B	C	D	E	F
MCS028	496	620	745	993	660	1210
MCM035	523	653	784	1045	705	1293
MCM040	523	653	784	1045	705	1293
MCL055	627	784	940	1254	852	1562
MCM070	709	886	1064	1418	705	1293
MCM080	709	886	1064	1418	705	1293
MCL110	847	1059	1271	1695	852	1562
MCM160	983	1229	1475	1966	705	1293
MCL165	1020	1275	1530	2040	852	1562

8.5 Piping

Release the pressure



WARNING

The circuit is pressurized by nitrogen/helium at 2 bar.

Before welding the pipeline, discharge completely the circuit to release the pressure.

Connections

The inlet and outlet directions are clearly marked with labels and arrows on the respective pipings. Pay attention to follow the directions.

Take care of the sensors

While welding the pipeline, take care to disconnect the pressure transducer and the temperature sensor. Re-connect the pressure transducer and the temperature sensor once the welding operation is completed and the pipes have cooled down. Not present with Control by Indoor Unit.

Piping sizes

Model	Pipe IN	Pipe OUT
MCS028	22	16
MCM035		
MCM040		
MCL055	28	22
MCM070		
MCM080		
MCL110	35	28
MCM160	28	22
MCL165	35	28

Keep clean

- Keep piping clean and dry.
- Ensure that the tubing surfaces to be brazed are clean and that the ends of the tubes have been carefully reamed to remove any burrs.
- Ensure that all loose material has been cleaned from inside the tubing before brazing.

Brazing

NOTE - When copper is heated in the presence of air, copper oxide forms. POE oil will dissolve these oxides from inside the copper pipes and deposit them throughout the system, clogging filter driers and affecting other system components.

- Use copper piping with a brazing alloy with a minimum temperature of 732°C, such as Sil-Fos.
- Avoid soft solders such as 50/50 or 95/5.
- During brazing use pure dry nitrogen through the piping with a flow of 0.5-1.5 l/s

Vibration

- Isolate piping from building using vibration isolating supports.

Refrigerant charge



NOTICE

A not adequate charge of refrigerant could bring to inappropriate work of the refrigeration system.

Refer to the main unit user manual for the refrigerant charge operation.

8.6 Electrical Connections

8.6.1 General Instructions

Specifications	<ul style="list-style-type: none"> • Check the electrical data on the label applied on the unit. • Check that the available power supply is consistent with the unit power requirements given in 6.1 <i>Technical Data and Performances</i>. • Refer to the electrical schematic supplied with the condenser when making line voltage supply, low voltage main unit interlock and any low voltage alarm connections. • Make sure all electrical connections are tight. • Electrical service must conform to national and local electrical codes. • All wiring must be done in accordance with all applicable local, state, and national electrical codes. • Use copper wiring only. • For specific electrical requirements, see the electrical schematic provided with the unit. • The voltage supply to the condenser might be different from voltage supply to the main unit.
Outdoor	<ul style="list-style-type: none"> • The protection tube or shielded line is required for the outdoor part of the connecting cable between the main unit and the condenser.
Sealing	<ul style="list-style-type: none"> • When leading the cable through the joint, you are recommended to use the sealant for waterproof disposal. • If you do not follow the recommended cable sizes and mode to connect the cables, water leakage may occur at the waterproof joint.
Hot surfaces	<ul style="list-style-type: none"> • The cables cannot contact with hot objects, such as the copper pipe and water pipe without thermal insulation pipe, lest the insulation layers should be damaged.
Disconnecting switch and protection	<ul style="list-style-type: none"> • A manual electrical disconnect switch should be installed in accordance with local codes. • Select and install the line side electrical supply wire and over current protection device(s) according to the specifications on the unit nameplate(s), per the instructions in this manual and according to the applicable national, state, and local code requirements.

8.6.2 Connection to the Power Supply

Specifications for MC equipped with EC fans

Use WYE power supply connection

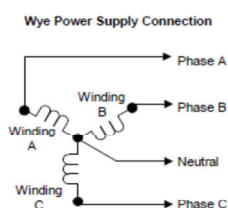

Delta Power Supply Connection

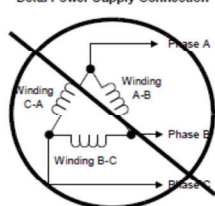

NOTICE

The **Liebert® MC** Condenser equipped with EC Fan Models is designed to operate with Wye-connected power.

It will not operate properly with Delta connected power.

The neutral is for illustration purpose only and is not necessary for the condenser to function properly.

A field-supplied isolation transformer or other power solutions will be needed to for proper condenser function.

The electronically commutated motors included in the **Liebert® MC** are suitable for connection to power supplies with a solidly grounded neutral.

Acceptable Power Supplies - 380V to 460V Nominal Units

- 380V wye with solidly grounded neutral and 220V line-to-ground
- 460V wye with solidly grounded neutral and 277V line-to-ground

Unacceptable Power Supplies - 380V to 460V Nominal Units

- Wye with high-resistance (or impedance) ground
- Delta without ground or with floating ground
- Delta with corner ground
- Delta with grounded center tap

Wiring Instructions

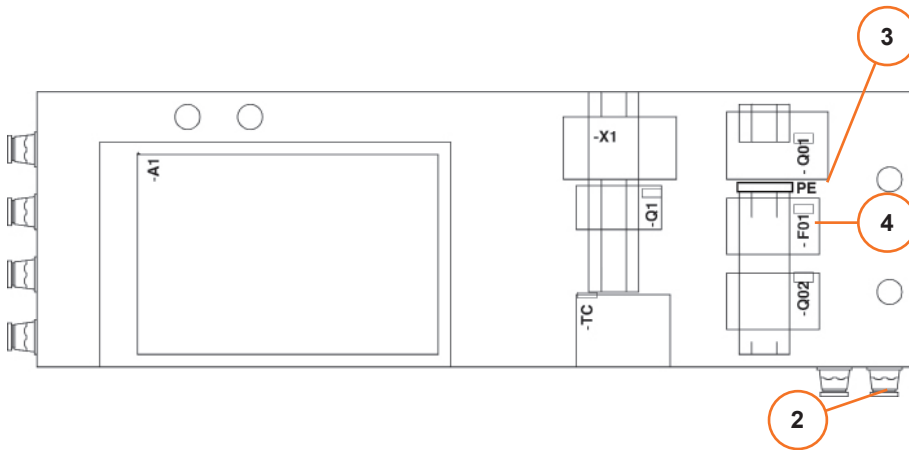

1. Route the power supply cable to the site disconnect switch and then to the unit.
2. Route the conduit to the knockout provided in the bottom right end of the electrical control enclosure.
3. Connect the earth ground wire lead to the marked earth ground connection terminal provided near the factory-installed disconnect switch.
4. Connect the three-phase cable to the factory-installed disconnect switch.

8.6.3 Connection of the Premium Controller to the Main Unit (Low Voltage Connection)



NOTICE

Risk of control malfunction.

Can cause improper unit operation.

Make sure that all low voltage electrical wiring has been performed per the schematic diagram provided and that all low voltage wiring connections are tight.

Specifications

CANbus	<p>Premium Efficiency Control condensers are designed to use CANbus communication between Liebert® MC and Liebert® iCOM™ control on main unit.</p> <p>The CANbus wiring is field-supplied and must be:</p> <ul style="list-style-type: none"> - shielded - 24-18 AWG (0.20-0.82 mm²) stranded tinned copper - twisted pair (minimum 8 twists per foot) - low capacitance (17pF/ft or less) - plenum rated (NEC type CMP) if required by local codes - UV and moisture resistant or run within conduit once in an outdoor environment, and must be temperature and voltage rated for conditions present. <p>Examples: Belden part number 89207(plenum rated) or Alpha Wire part number 6454 (UV resistant outdoor rated) category 5, 5e or higher.</p>
Cautions	<p>Do not run the CANbus cable in the same conduit, raceway or chase used for high-voltage wiring. For CANbus network lengths greater than 107m, contact Vertiv for assistance.</p>
Signals	<p>Premium Efficiency Control condenser are also designed to operate with Terminals 700 and 710 wired to main unit compressor contactor switch to indicate “compressor on” signal. These signals are always required with or without CANbus communication.</p>

Wiring Instructions

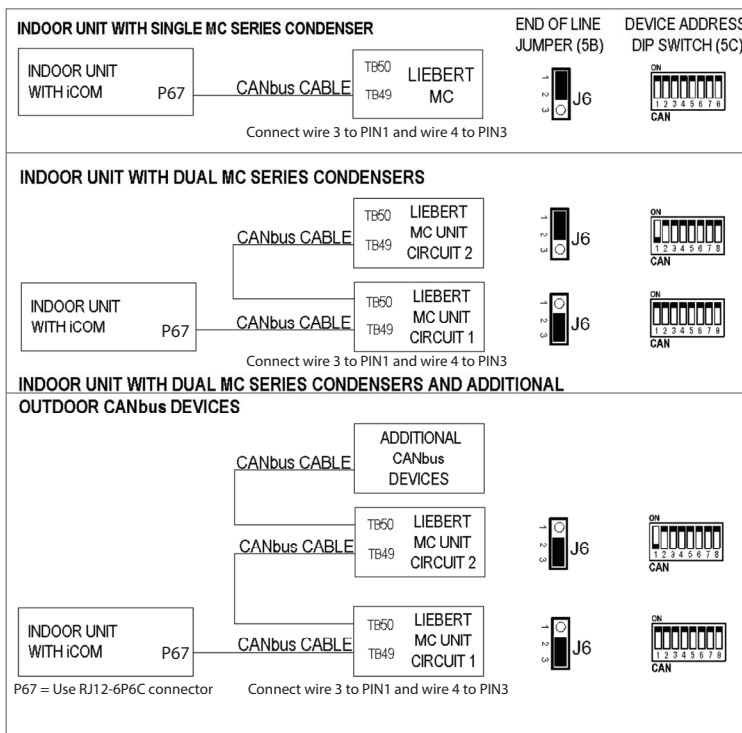
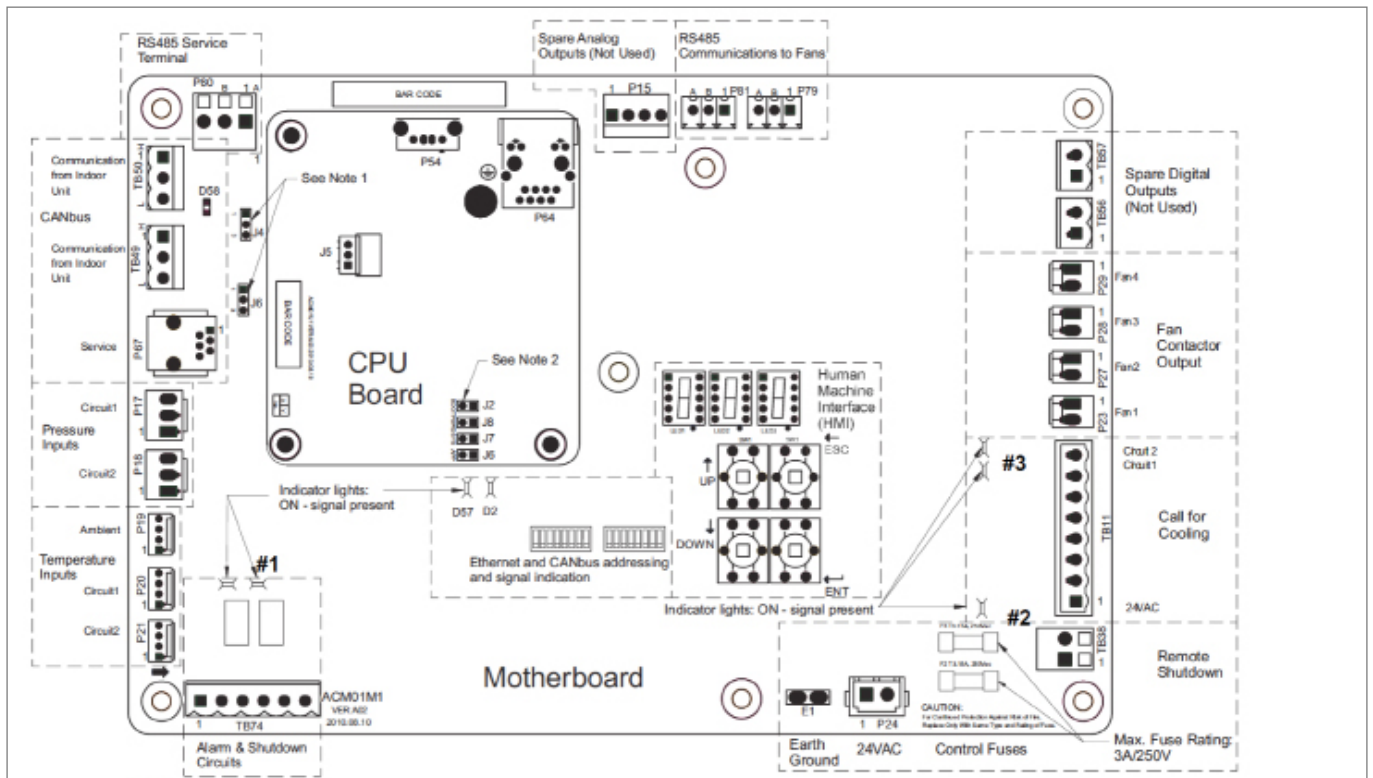

Field terminals for CANbus cable connection:

- TB49-1 is the input terminal for CANbus high.
- TB49-3 is the input terminal for CANbus low.
- TB50-1 is the output terminal for CANbus high.
- TB50-3 is the output terminal for CANbus low.
- Each CANbus cable shield is connected to terminal "SH". The shield of CANbus field-supplied cables must not be connected to ground at the condenser.
- J6 link is the "END OF LINE" jumper.
- CANbus Switch "DEVICE ADDRESS DIP SWITCH." CANbus cable not by Liebert®.
- Remote unit shutdown-Replace exiting jumper between Terminals TB38-1 and TB38-2 with field-supplied normally closed switch having a minimum 75VA 24VAC rating. Use field-supplied Class 1 wiring.

Alarm terminal connections

- Common Alarm Relay indicates when any type of alarm occurs. TB74-1 is common, TB74-2 is normally open, and TB74-3 is normally closed. 1 Amp 24VAC is the maximum load. Use field supplied Class 1 wiring.
- Shutdown Alarm Relay indicates when condenser loses power, or when a critical alarm has occurred that shuts down the condenser unit. TB74-4 is common; TB74-5 is normally open; and TB74-6 is normally closed. 1 Amp 24VAC is the maximum load. Use field supplied Class 1 wiring.

8.6.4 Controlled by indoor Unit



NOTICE

Risk of control malfunction.

Can cause improper unit operation.

Make sure that all low voltage electrical wiring has been performed per the schematic diagram provided and that all low voltage wiring connections are tight.

Specifications

Modbus	<p>HCR EC remote condensers are designed to use Modbus communication between Liebert® HCR and Liebert® iCOM™ control on main unit.</p> <p>The Modbus wiring is field-supplied and must be:</p> <ul style="list-style-type: none"> • shielded • 24-18 AWG (0.20-0.82 mm²) stranded tinned copper until 107m , 18-16 AWG (0.82-1.31 mm²) stranded tinned copper until 200m • twisted pair (minimum 8 twists per foot) • low capacitance (17pF/ft or less) • plenum rated (NEC type CMP) if required by local codes • UV and moisture resistant or run within conduit once in an outdoor environment, and must be temperature and voltage rated for conditions present. <p><i>Examples:</i> Belden part number 89207(plenum rated) or Alpha Wire part number 6454 (UV resistant outdoor rated) category 5, 5e or higher.</p>
Cautions	<p>Do not run the Modbus cable in the same conduit, raceway or chase used for high-voltage wiring.</p> <p>Mandatory shield connection to ground close Master (indoor unit control board)</p> <p>For Modbus network lengths greater than 200m, contact Vertiv™ for assistance.</p>
Addressing	<p>All the MC condensers are shipped with standard fan addressing: 31, 32 (up to 4 fans). In case of dual circuit units, it is required to change the addressing of fan of the second circuit in 41, 42, 43, 44, respectively.</p>

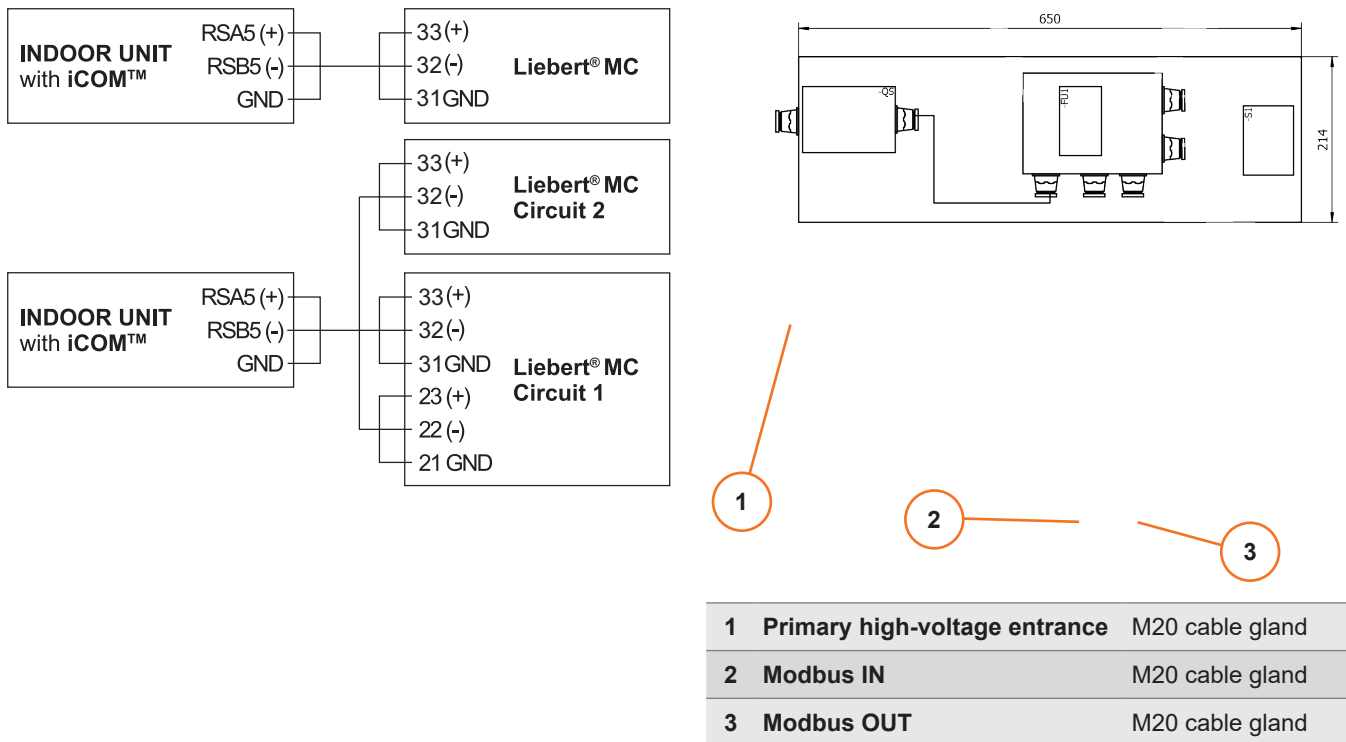

9. Unit Controller

9.1 Premium Board

9.1.1 Operation Description

Control boot-up	<p>The Liebert® MC Premium Efficiency Control takes approximately 30 seconds to boot up once power is applied to the condenser.</p> <p>The LED on the Premium Efficiency Control Board reads “888” while the board is booting up.</p> <p>Once the control has booted up, the display shows “F00” and then the value for F00.</p>
Fan(s) rotation	<p>With the control ON, the condenser fan(s) turn in less than 5 seconds after receiving a signal from the main unit that the compressor(s) are ON.</p> <p>For the first 60 seconds of operation after the compressor turns on, the condenser fan(s) will run at a fixed speed, set at the factory, based on ambient temperature: faster at higher temperatures, slower at lower temperatures.</p> <p>After 60 seconds, the control adjusts the fan speed based on the liquid pressure transducer.</p> <p>If the liquid pressure transducer fails, the condenser uses temperature sensors to control the fan speed based on the liquid line temperature.</p> <p>The condenser fans continue to operate for approximately 30 seconds after compressors turn OFF.</p>
UPS	<p>Consider using UPS equipment on both data center cooling units and Liebert® MC condensers to maintain uninterrupted cooling capability.</p>
Alarms	<p>The Liebert® MC fans have various alarm conditions, such as loss of voltage and loss of control signal, which will stop the condenser fans.</p> <p>Once the alarm condition is no longer present the Liebert® MC fans will turn on automatically if compressors are ON.</p>

This chapter introduces the application of the controller (including fan speed controller and communication board), which includes the definitions of wiring terminals, introduction of human-Machine Interface (HMI) and operation of HMI.



NOTICE

This chapter is MAINLY for factory maintenance personnel. Risk of improperly altered configuration menu settings can compromise the unit operation.

Changing the configuration menu settings can cause unanticipated results. These settings should be changed only by properly trained and qualified personnel or as directed by the factory.

9.1.2 Communication Board

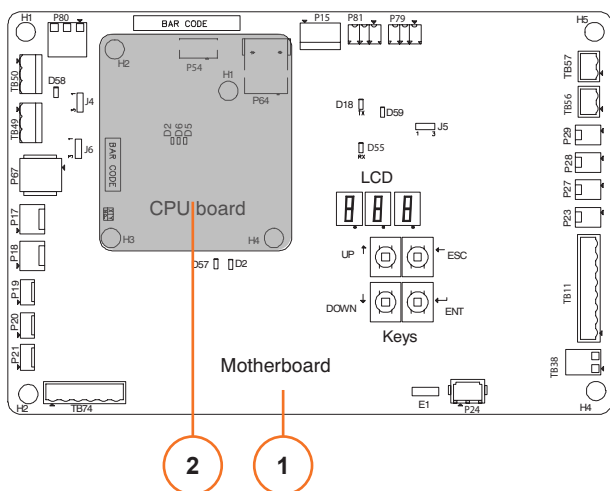

The **Liebert® MC** Premium Efficiency Control board has a stacked board arrangement, it is composed by:

1. Motherboard
2. CPU board (inserted in the motherboard)

Wiring Terminals

The figure below shows the wiring terminals, which are located on the motherboard.

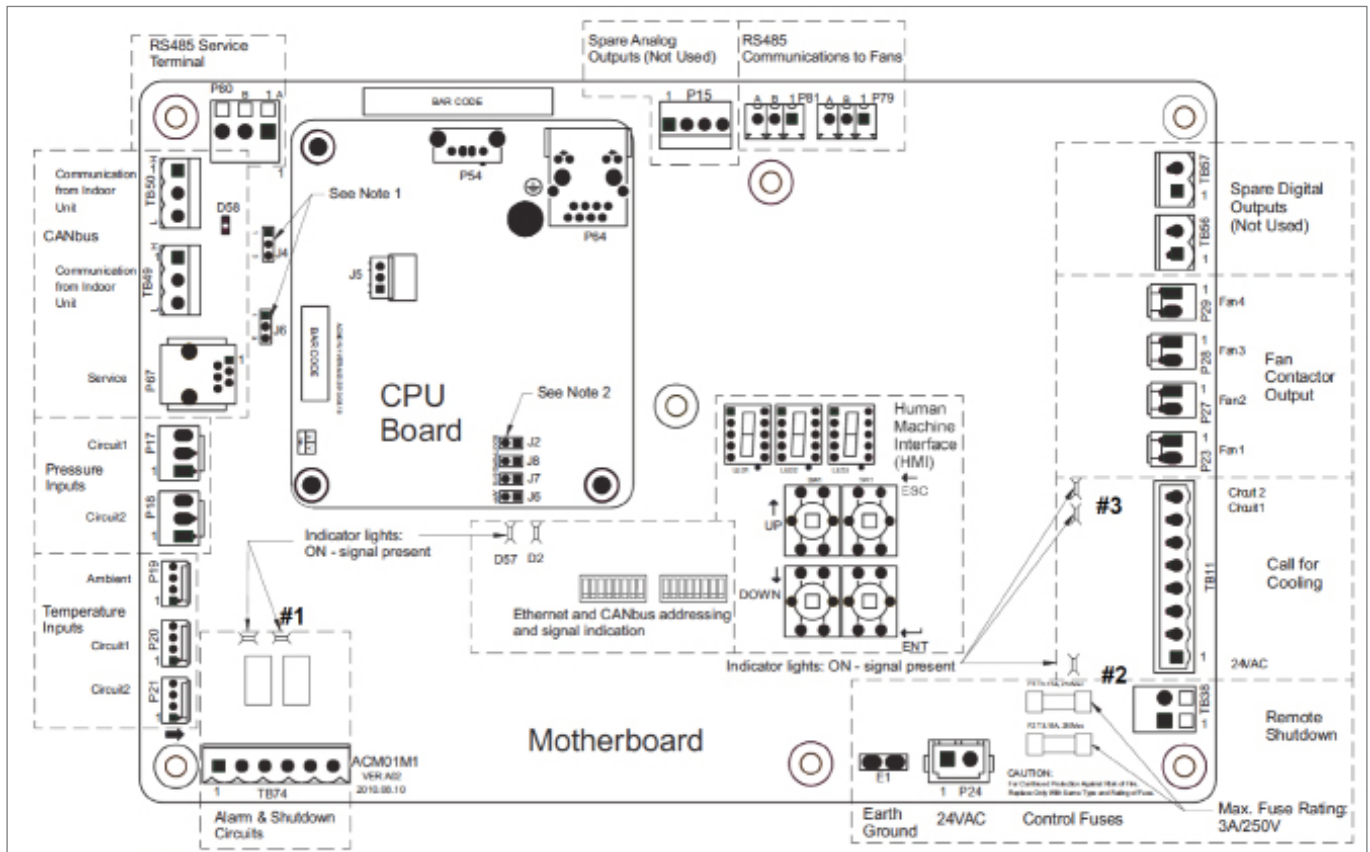

The table below shows the wiring terminals definitions:

Silk print	Definition	Definitions of terminal pins
P24	24V AC input terminal	Pin 1: 24V AC input terminal Pin 2: 24V AC return terminal
E1	PE terminal of 24V AC return terminal	Pin 1: PE terminal of 24V AC return terminal
P17	Input terminal of pressure transducer 1	Pin 1: positive terminal of 5V power Pin 2: 0.5V ~ 4.5V input terminal of pressure voltage signal Pin 3: negative terminal of 5V power
P18	Input terminal of pressure transducer 2	
P23	Control & output terminal of fan 1	Pin 1: 24V AC output terminal
P27	Control & output terminal of fan 2	Pin 2: 24V AC return terminal
P28	Control & output terminal of fan 3	
P29	Control & output terminal of fan 4	
TB56, TB57	Output terminal of spare switch	Pin 1: 24V AC output terminal Pin 2: 24V AC return terminal
P19	Input terminal of ambient temperature	Pin 1: temperature input terminal 1
P20	Input terminal of condensing temperature 1	Pin 2: not used
P21	Input terminal of condensing temperature 2	Pin 3: temperature input terminal 2 Pin 4: not used

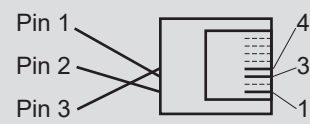
Silk print	Definition	Definitions of terminal pins
TB74	Output terminal of common alarm	Pin 1: COMM terminal of common alarm relay Pin 2: normally-open contact of common alarm relay Pin 3: normally-closed contact of common alarm relay Pin 4: COMM terminal of faulty shutdown alarm relay Pin 5: normally-open contact of faulty shutdown alarm relay Pin 6: normally-closed contact of faulty shutdown alarm relay
TB49, TB50	CAN port terminal	Pin 1: high level of CAN port Pin 2: ground of CAN port Pin 3: low level of CAN port 
TB11	Fan input terminal	Pin 1: 24Vac common terminal Pin 2: TVSS input terminal Pin 3: FAN Overload 1 Pin 4: FAN Overload 2 Pin 5: FAN Overload 3 Pin 6: FAN Overload 4 Pin 7: Compressor feedback circuit 1 Pin 8: Compressor feedback circuit 2
P67	Modular jack of CAN port	Pin 1: ground of CAN port Pin 2: not used Pin 3: high level of CAN port Pin 4: low level of CAN port Pin 5: not used Pin 6: ground of CAN port
P80	RS485 port terminal (spare)	Pin 1: A terminal of RS485 port Pin 2: B terminal of RS485 port Pin 3: ground of RS485 port
P79, P81	RS485 port terminal (connecting to fan)	Pin 1: ground of RS485 port Pin 2: B terminal of RS485 port Pin 3: A terminal of RS485 port
P15	Two routes 0 ~ 10V analog output terminal	Pin 1: 0 ~ 10V analog output 1 Pin 2: ground of analog output Pin 3: 0 ~ 10V analog output 2 Pin 4: ground of analog output
TB38	Remote shutdown terminal	Pin 1: Remote shutdown terminal 1 Pin 2: Remote shutdown terminal 2
P54	USB port	Standard USB port
P64	Ethernet port	Standard Ethernet port

NOTE: The pin with an arrow marked on the terminal base is Pin 1

NOTE

- J6 is the CANbus termination jumper. J4 is the RS485 service termination jumper.
 If the condenser is the last device in the CANbus communication line, the jumper must be placed between Pins 1 and 2 of J6. If the condenser is not the last device in the CANbus communication line, the jumpers on J6 must be placed on Pins 2 and 3.
 If the jumper is not in the correct positions, CANbus communication errors may occur.
 The jumper on J4 will always be placed between Pins 1 and 2.
- A jumper must be present at J2. If a jumper is not present, the control board will not boot properly during power startup.

Indicators on the Motherboard Board

Position on the motherboard

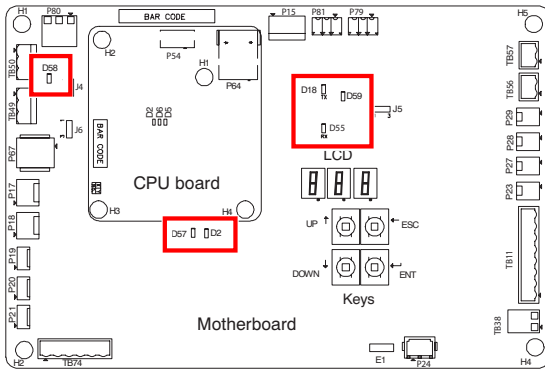

Functions

Silk print	Definition	Color	State	Functions
D2	Communication indicator	Green	Blinking	The CAN port is communicating
			Off	The CAN port is not communicating
D18	Communication indicator	Green	Blinking	The RS485 terminal of the controller is sending signals
			Off	The RS485 terminal of the controller is not sending signals
D55	Communication indicator	Yellow	Blinking	The RS485 terminal of the controller is receiving signals
			Off	The RS485 terminal of the controller is not receiving signals
D57	Power indicator	Yellow	On	The 3.3V power supply of the controller is normal
			Off	The 3.3V power supply of the controller is abnormal
D58	Power indicator	Yellow	On	The power supply of the controller CAN port is normal
			Off	The power supply of the controller CAN port is abnormal
D59	Power indicator	Yellow	On	The power supply of the controller RS485 port is normal
			Off	The power supply of the controller RS485 port is abnormal

9.1.3 Control Operation

Initial Screen Upon Power-on

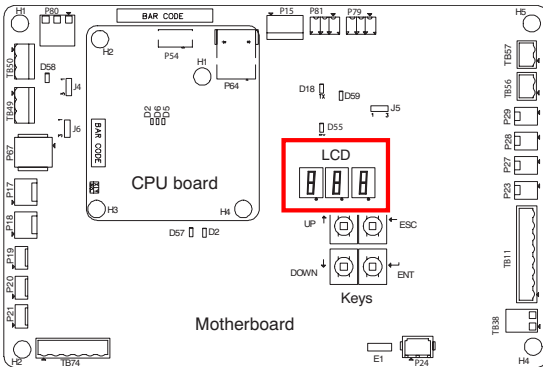

The controller displays the initial screen after it is powered on.

The initial screen shows the first item of analog signals menu.

The “**F00**” and value of condenser pressure “**1**” are displayed alternatively and “**F00**” means the item ID of condenser pressure “**1**”.

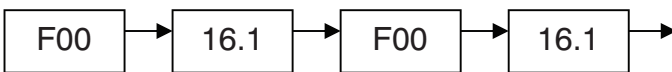

The figure shows the display sequence, where “**16.1**” is an example value.

The actual value is dependent on the sampling result.

Main Menu

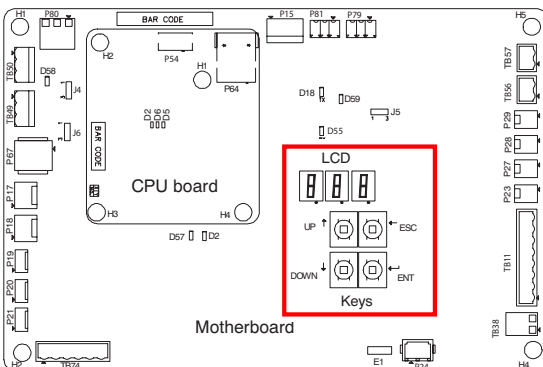

In initial screen, presses **ESC** key, the LED enters the main menu.

The main menu includes five sub-menus:

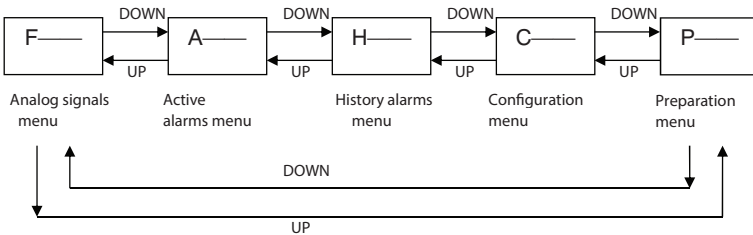

In the main menu, press **UP** and **DOWN** keys to switch to different menus, and press **ENT** key to enter the sub menus of current menu.

The operation and structure of main menu are shown in the figure.

Analog Signals Menu

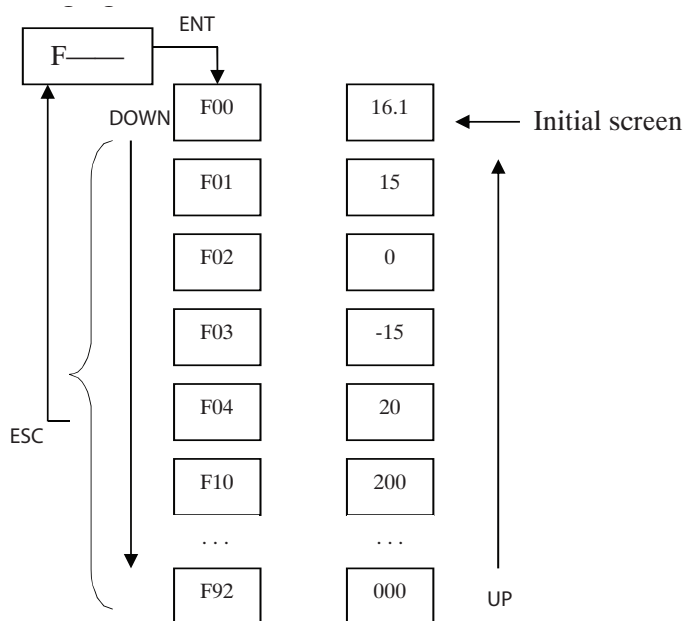

In analog signals menu “F—”, press **ENT** key to enter its items

The information of analog signal items includes condenser pressure, temperature and EC FAN actual speed.

The display mode is that the item ID and signal value are displayed alternatively.

The operation and item structure of analog signals menu are shown in the figure.

The meanings of the items of analog signals are given in the following table:

Item ID	Meaning	Units (C90)	
		Metric	Imperial
F00	Condenser pressure 1	bar	psi
F01	Condenser pressure 2	bar	psi
F02	Ambient temperature	°C	°F
F03	Refrigerant temperature 1	°C	°F
F04	Refrigerant temperature 2	°C	°F
F10	EC FAN1 actual speed	RPM	RPM
F11	EC FAN1 requested speed	%	%
F20	EC FAN2 actual speed	RPM	RPM
F21	EC FAN2 requested speed	%	%
F30	EC FAN3 actual speed	RPM	RPM
F31	EC FAN3 requested speed	%	%
F40	EC FAN4 actual speed	RPM	RPM
F41	EC FAN4 requested speed	%	%
F50	Subcooling 1	°C	°F
F51	Subcooling 2	°C	°F
F90	Firmware Version Major		
F91	Firmware Version Minor		
F92	Firmware Version Build		

Alarm Codes:

Active Alarms Menu

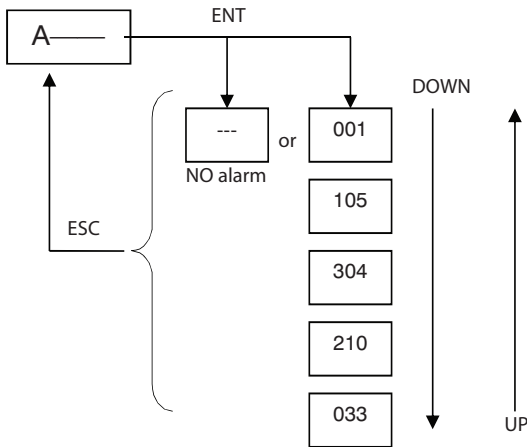

In active alarms menu “A—”, press **ENT** key to enter its items.

The active alarm item displays all the active alarms of condenser.

When there is an active alarm, the alarm information ID will be directly displayed.

When there is no alarm, “-” is displayed.

When there are multi alarms, the alarm information IDs will be displayed according to the time sequence, that is, the latest alarm will be displayed first.

The operation and items structure of active alarms menu are shown in the figure.

The meanings of alarm information ID are given in *Alarm Information*.

History Alarms Menu

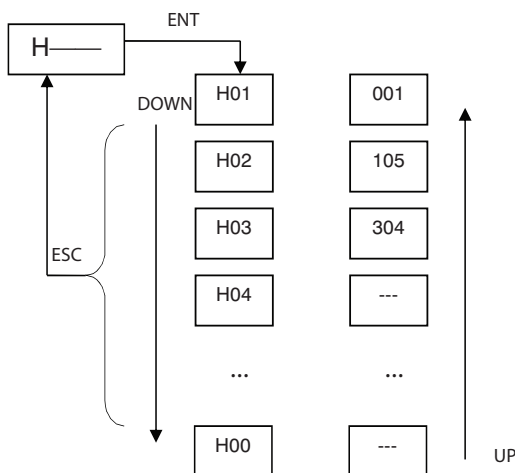

In history alarms menu “H—”, press ENT key to enter its items.

The history alarm items display 100 history alarm records of the condenser.

The item ID is for the sequence number of the history alarms.

The display mode is that the item ID and alarm information ID are displayed alternatively.

When there is no alarm, “-” is displayed.

Alarm history can be cleared using the C90 configuration menu item described later in this document.

The operation and items structure of history alarms menu are shown in the figure.

The meanings of alarm information ID are given in *Alarm Information*.

Alarm Information

Alarm ID	Meaning	Possible Cause	Handling Method
000	CAN communication failure	Communication circuit missing or damaged	Check communication circuit. Ignore alarm on condensers without CAN connections
001	Ethernet communication failure	Ethernet hardware or connection failure	Ignore alarm, Ethernet connection is not present
002	USB communication failure	USB device or file is damaged.	Replace USB device or file.
003	Data corruption	Memory chip is damaged	Replace PCB board
004	System error	Internal error	Reboot. If reboot fails, consult factory.
005	Remote shutdown	1. Remote shutdown signal is available 2. TB38 is not connected	For Cause 1, check the remote shutdown signal. For Cause 2, connect TB38.
006	Shutdown due to EC Fan alarm	All fans have failed	Consult factory
007	SPD alarm	SPD damaged	Replace SPD

Alarm ID	Meaning	Possible Cause	Handling Method
008	Condenser pressure Sensor 1 failure	Condenser pressure Sensor 1 damaged	Replace condenser pressure Sensor 1
009	Condenser pressure Sensor 2 failure	Condenser pressure Sensor 2 damaged	Replace condenser pressure Sensor 2
010	Condenser pressure 1 high alarm	High pressure: Fan failure, clogged coils. Low pressure: Loss of charge	High-pressure alarms: Fix fan and clean coil. Low-pressure alarms: Check for refrigerant leak.
011	Condenser pressure 2 high alarm		
012	Condenser pressure 1 low alarm		
013	Condenser pressure 2 low alarm		
014	EC Fan speed mode maximum must be overridden due to condenser pressure 1 high	Condenser pressure 1 high	No action is needed.
015	EC Fan speed mode maximum must be overridden due to condenser pressure 2 high	Condenser pressure 2 high	No action is needed.
016	Ambient temperature sensor failure	Ambient temperature sensor damaged	Replace ambient temperature sensor
017	Ambient temperature high alarm	Ambient temperature high	No action is needed.
018	Ambient temperature low alarm	Ambient temperature low	No action is needed.
019	Condenser temperature Sensor 1 failure	Condenser temperature Sensor 1 damaged	Replace condenser temperature Sensor 1
020	Condenser temperature Sensor 2 failure	Condenser temperature Sensor 2 damaged	Replace condenser temperature Sensor 2
021	Condenser temperature 1 high alarm	High temperature: Fan failure, clogged coils. Low temperature: Consult factory	High-temperature alarms: Fix fan and clean coils. Low-temperature alarms: consult factory.
022	Condenser temperature 2 high alarm		
023	Condenser temperature 1 low alarm		
024	Condenser temperature 2 low alarm		
025	EC Fan speed mode maximum must be overridden due to refrigerant temperature 1 high	Refrigerant temperature 1 high	No action is needed.
026	EC Fan speed mode maximum must be overridden due to refrigerant temperature 2 high	Refrigerant temperature 2 high	No action is needed.
(1-4) 00	EC Fan high link current	1. EC Fan is locked. 2. EC Fan is damaged.	For cause 1, check if EC Fan is locked. For cause 2, replace EC Fan
(1-4) 01	EC Fan drive error	EC Fan is damaged.	Replace EC Fan
(1-4) 02	EC Fan earth to ground fault	EC Fan is damaged.	Replace EC Fan
(1-4) 03	EC Fan electronics heat sink thermal overload	1. EC Fan is locked. 2. EC Fan is damaged. 3. Ambient temperature is too high	For cause 1, check if EC Fan is locked. For cause 2, replace EC Fan For cause 3, check ambient temperature.
(1-4) 04	EC Fan Hall failure	EC Fan is damaged.	Replace EC Fan
(1-4) 05	EC Fan IGBT failure	EC Fan is damaged.	Replace EC Fan
(1-4) 06	EC Fan line fault	Power supply abnormal	Check power supply
(1-4) 07	EC Fan motor locked	Motor is locked	Check if EC Fan is locked.
(1-4) 08	EC Fan motor thermal overload	1. EC Fan is locked. 2. EC Fan is damaged. 3. Ambient temperature is too high	For cause 1, check if EC Fan is locked. For cause 2, replace EC Fan For cause 3, check ambient temperature.

Alarm ID	Meaning	Possible Cause	Handling Method
(1-4) 09	EC Fan phase failure alarm	Phase failure	Check power supply
(1-4) 10	EC Fan-specific uncategorized alarm detected	Internal EC Fan issue	Re-boot condenser if fans not running. If alarm persists and fans not running, replace fan.
(1-4) 11	EC Fan-specific uncategorized warning detected		
(1-4) 12	EC Fan electronics high-temperature condition.	<ol style="list-style-type: none"> 1. EC Fan is locked. 2. EC Fan is damaged. 3. Ambient temperature is too high 	<p>For cause 1, check if EC Fan is locked.</p> <p>For cause 2, replace EC Fan</p> <p>For cause 3, check ambient temperature.</p>
(1-4) 13	EC Fan high link voltage	<ol style="list-style-type: none"> 1. EC Fan input power supply high voltage 2. EC Fan is damaged. 	<p>For cause 1, measure power supply voltage and check if the voltage is normal</p> <p>For cause 2, replace EC Fan</p>
(1-4) 14	EC Fan low link voltage	<ol style="list-style-type: none"> 1. EC Fan input power supply low voltage 2. EC Fan detection error 	
(1-4) 15	EC Fan 485 communication failure	<ol style="list-style-type: none"> 1. Communication between EC Fan and PCB board failure 2. EC Fan 485 communication failure 3. Board has problems 4. EC fan not receiving power 	<p>For cause 1, check EC Fan communication circuit</p> <p>For cause 2, replace EC Fan</p> <p>For cause 3, replace PCB board</p> <p>For cause 4, check fan model is not set for "0", check that the contactor for the particular fan is energized, and check fan fuses.</p>

NOTE (1-4) means the EC FAN addresses. For example, (1-4) 00 means 100 for EC FAN1, and means 200 for EC FAN2, and means 300 for EC FAN3, and means 400 for EC FAN4.

Configuration Menu

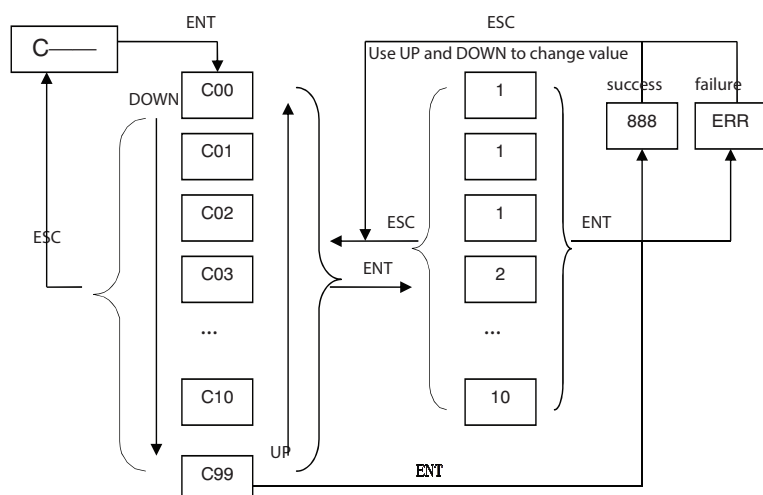

In configuration menu “C—”, press **ENT** key to enter its items

The operation and items structure of configuration menu are shown in the figure.

The meanings of the items of configuration menu are given in following table:

ITEM ID	Meaning	Default*		Note
		Metric	Imperial	
C00	EBM EC FAN Address	1	1	EC FAN address ranges from 1 to 4, starting from 1. Valid EC FAN model (C03-C06) must be set prior to addressing
C01	ZIEHL ABEGG EC FAN Address	1	1	
C02	FANS TECH EC FAN Address	1	1	
C03	EC FAN1 model ID	0	0	0-None
C04	EC FAN2 model ID	0	0	1-EBM
C05	EC FAN3 model ID	0	0	2-ZIEHL ABEGG
C06	EC FAN4 model ID	0	0	3-Fans Tech
C07	System model ID	0	0	0-Single circuit 1-Dual Circuit
C09	System refrigerant type	3	3	1-R22 2-R407C 3-R410A
C10	Condenser pressure absolute max 1	31 bar	450 psi	
C11	Condenser pressure absolute max 2	31 bar	450 psi	
C12	Condenser pressure absolute min 1	21 bar	305 psi	
C13	Condenser pressure absolute min 2	21 bar	305 psi	
C14	Condenser pressure PID Kp	1	1	
C15	Condenser pressure PID Kip	0,02	0,02	
C16	Condenser pressure PID Kdp	0	0	
C17	Refrigerant temperature max 1	35°C	95 °F	
C18	Refrigerant temperature max 2	35°C	95°F	
C19	Refrigerant temperature min 1	25°C	77°F	
C20	Refrigerant temperature min 2	25°C	77°F	
C21	Refrigerant pressure PID Kp	1	1	
C22	Refrigerant pressure PID Kip	0,02	0,02	
C23	Refrigerant pressure PID Kdp	0	0	
C24	System Control State	1	1	0-Manual 1-Automatic
C25	Condenser pressure setting point 1	23 bar	334 psi	
C26	Condenser pressure setting point 2	23 bar	334 psi	

ITEM ID	Meaning	Default*		Note
		Metric	Imperial	
C27	System LeeTemp option	0	0	0-No Lee Temp Installed 1-Lee Temp installed
C28	VSD minimum speed for Lee Temp	10%	10%	
C32	Refrigerant temp. set point 1	38°C	100°F	
C33	Refrigerant temp. set point 2	38°C	100°F	
C34	EC FAN1 Request Fans Speed	0%	0%	These values can be manually set only when system control state (C24) is Manual
C35	EC FAN2 Request Fans Speed	0%	0%	
C36	EC FAN3 Request Fans Speed	0%	0%	
C37	EC FAN4 Request Fans Speed	0%	0%	
C38	EC FAN Speed Reverse Request	0	0	0-Off 1-On
C50	SysCtrlSrc 1			Internal System test use only
C51	SysCtrlSrc 2			
C52	Feed Foward 1			
C53	Feed Foward 2			
C54	PID N			
C55	PID Kb			
C56	PID Kt			
C57	Fan Speed Duty Cycle 1			
C58	Fan Speed Duty Cycle 2			
C90	Prefered display units	0	1	0-Metric 1-Imperial
C91	Save configuration to USB flash drive			No value. Pressing ENTER will execute the function immediately
C92	Load configuration from USB flash drive			No value. Pressing ENTER will execute the function immediately
C98	Clear alarm history			No value. Pressing ENTER will execute the function immediately
C99	Restore all parameters to default values. Note that EC FAN models will be reset to 0 but EC FAN address will not be affected			No value. Pressing ENTER will execute the function immediately

* **Default** values provided are based on a system base configuration consisting of a single-circuit, R410A system with no Low Temp. These values may be different due to updates applied during production. These updates reflect the intended site configuration.

Preparation Menu

The preparation menu “**P—**” operates similar to the configuration menu, press **ENT** key to enter its items.

This menu allows for compact setup/preparation of the unit either in the factory or at a site installation.

Use these functions to establish a default control configuration for the board.

The descriptions of items in the preparation menu are described in the table below.

Item ID	Meaning	Default	Notes
P01	Enter preparation mode	0	Setting this value to ‘1’ will enable preparation mode. All other ‘ P— ’ menu items will be disabled until this value is ‘1’. Note that control operations may be affected during preparation mode therefore the main unit should be OFF . Setting this value back to ‘0’ will cause the board to create new default values based upon selections in this menu. After default values are established the board will exit preparation mode and reboot.
P02	Automatic EC FAN configuration	1	This item should only be used to address the EC FANs for the unit. The value entered indicates the model of the EC FAN: 1 – EBM 2 – Ziehl Abegg 3 – Fans Tech All fans must be the same model. When you push ‘ ENT ’ the board will operate the power contactors for the EC FANs and assign Modbus addresses. This procedure may take up to 5 minutes to complete. TODO: Describe progress indicators on the LED.
P03	Refrigerant type	2	1 – R22 2 – R407C 3 – R410A
P04	Number of circuits	1	1 – Single Circuit 2 – Dual Circuit
P05	Lee Temp option	0	0 – No Lee Temp installed 1 – Lee Temp installed
P06	Condenser size	1	0 – Small 1 – Medium 2 – Large

NOTE 1 Procedures of setting EC FAN model ID:

1. Check the EC FAN NO. that its model ID needs to be set. If it is the first time to set EC FAN model ID, all the EC FANs from NO.1 to NO.4 should be set, or only the replaced EC FANs need to be set.
2. Set the EC FAN model ID according to the EC FAN NO. If there is a EC FAN available for current EC FAN NO., then set the EC FAN model ID. If the EC FAN is from EBM, set the ID to 1; If the EC FAN is from ZIEHL_ABEGG, set the ID to 2; If the EC FAN is from Fans_Tech, set the ID to 3. If there is no EC FAN for current EC FAN NO., set the ID value to 0.
3. After all settings done for EC FANs, turn off the circuit breaker of the PCB board and then re-power on to validate the settings.

NOTE 2 Procedures of setting EC FAN address:

1. Confirm that the model ID for each EC FAN has been set correctly and the board has been reset per instructions in Appendix 2.
2. The EC FAN addresses should be set one by one, that is, the address of only one EC FAN can be set at one time. Plug the terminal of contactor for the EC FAN to the jack in the PCB board, and keep the other terminals of contactors unplugged from the PCB board.
3. Set the address through different menus according to the EC FAN model. EBM EC FAN should be set via C00 menu; ZIEHL_ABEGG EC FAN should be set via C01 menu; Fans_Tech EC FAN should be set via C02 menu; The EC FAN address should be same as the EC FAN NO., that is, the address of NO. 1 should be set to 1.
4. After all settings done for EC FANs, turn off the circuit breaker of the PCB board and re-power on to validate the settings. Recommend setting manual speeds for all EC FANs by setting C24 to 0 (manual) and then using C34-C37 to set manual speed request. Ensure to set C24 back to 1 (automatic) after testing.

9.2 Basic board

9.2.1 One phase power supply

COMPONENT COMPONENTE	FACTORY SETTING SETTAGGIO DI FABBRICA	OPERATION FUNZIONAMENTO	HOW TO SET COME TARARE
Variex CAREL Single circuit Monocircuito	DEFAULT VALUE VALORE DI DEFAULT SET 1 = 23.4 barg DIFF 1 = 5.4 barg CUT OFF 1 = 19.3 barg OPTIONAL VALUE VALORE OPZIONALE SET 2 = 20.2 barg DIFF 2 = 5.4 barg CUT OFF 2 = 16.1 barg		<p>The fan speed controller is factory preset at the default set point value (set point 1 = 23.4 barg). TERMINALS 70-71 on electrical panel, if normally open 24Vac (default value) then higher set point (set point 1), if normally closed 24Vac (optional value) then lower setpoint (set point 2). Il regolatore di velocità dei ventilatori viene tarato in fabbrica al valore di set point di default (set point 1 = 23.4 barg). MORSETTI 70-71 sul quadro elettrico: se normalmente aperti 24 Vac (valore di default) il set point è più alto (set point 1 = 23.4 barg), se normalmente chiusi 24Vac (valore opzionale) il set point è più basso (set point 2 = 20.2 barg).</p>
Variex CAREL Double circuit Bicircuito (set dip switch 3 ON)	DEFAULT VALUE VALORE DI DEFAULT SET 1 = 23.4 barg DIFF. 1 = 5.4 bar OPTIONAL VALUE VALORE OPZIONALE SET 2 = 20.2 barg DIFF. 2 = 5.4 bar The optional set point is available only with condensers coupled with conditioners working with EEV valve device (electronic expansion valve). Il set point opzionale è utilizzabile solo con condensatori abbinati a condizionatori dotati di valvola EEV (valvola di espansione elettronica).		<p>The fan speed controller is factory preset at the default set point value (set point 1 = 23.4 barg). TERMINALS 70-71 on electrical panel, if normally open 24Vac (default value) then higher set point (set point 1), if normally closed 24Vac (optional value) then lower setpoint (set point 2 = 20.2). Il regolatore di velocità dei ventilatori viene tarato in fabbrica al valore di set point di default (set point 1 = 23.4 barg). MORSETTI 70-71 sul quadro elettrico: se normalmente aperti 24 Vac (valore di default) il set point è più alto (set point 1 = 23.4 barg), se normalmente chiusi 24Vac (valore opzionale) il set point è più basso (set point 2 = 20.2 barg).</p>

Antifreeze function at low temperatures (opt.)

This is activated automatically at the preset temperature of equal to or less than 3°C and is deactivated as soon as the temperature rises to 4°C or the temperature is below -15°C.

The fan has fixed rest and working periods during this type of operation; it is normal for the fan(s) to operate even when not requested by the pressure sensor.

The regulator deactivates the antifreeze function automatically as soon as the regulation function is requested via the pressure transducer. For the antifreeze function, dip switch 4 must be in "ON" position and the NTC temperature sensor (code 275171) must be located between terminals B3 and GND.

If the dip switch is in "ON" position but the sensor is not connected or faulty, the fan will turn at maximum speed. To deactivate the function, simply move dip switch 4 to "OFF" position.

The following settings are fixed and cannot be changed.

T0 3.0 Set point temperature for anti-freezing function activation (°C).

TIME1 3.0 Duration of impulse at maximum voltage (30 seconds).

TIME2 1.5 Duration of interval between two impulses (15 minutes).

V0 230 Maximum voltage applied to the fan.

NTC sensor installation (code 275171)

The NTC sensor is supplied as an optional kit on request.

1. pass the cable of the sensor through the cable clamp immediately beneath terminals B3-GND.
2. fasten the bulb of the sensor close to the regulator with a band, out of the sun and away from heat sources, so that it can detect the temperature of the surrounding air; do not fasten it to the battery fins.
3. once installed set dip switch 4 to "ON".

COMPONENT COMPONENTE	FACTORY SETTING SETTAGGIO DI FABBRICA	OPERATION FUNZIONAMENTO	HOW TO SET COME TARARE
Antifreeze option Opzione antighiaccio (set dip switch 4 ON)	T0 = 3.0 °C TIME 1 = 3.0 (30 sec.) TIME 2 = 1.5 (15 min.) V0 = 230 V		<p>ntc sensor If installed with antifreeze option set dip switch 4 on</p>

9.2.2 Three phase power supply

Factory installed fan operation controller

Fan operation is monitored so as to control the condensing pressure. This is done using the continuous fan speed controller.

This is a factory installed device, the controller arrives already installed, cabled and set by the manufacturer Vertiv™.

Consult also the RDM300 kit manual.

Code	INPUT 1 (**)	INPUT 2 (**)	Digital Scroll filter ACTIVE	Set Point (value A or B)
FIX 1 A (*)	4–20 mA (scale 0 –45 bar)	NTC 10K@25°C (scale -20...+60°C)	NO	A
FIX 1 B	4–20 mA (scale 0 –45 bar)	NTC 10K@25°C (scale -20...+60°C)	NO	B
DGT 1 A	4–20 mA (scale 0 –45 bar)	NTC 10K@25°C (scale -20...+60°C)	YES	A
DGT 1 B	4–20 mA (scale 0 –45 bar)	NTC 10K@25°C (scale -20...+60°C)	YES	B
FIX 2 A	4–20 mA (scale 0 –45 bar)	4–20 mA (scale 0 –45 bar)	NO	A
FIX 2 B	4–20 mA (scale 0 –45 bar)	4–20 mA (scale 0 –45 bar)	NO	B

(*) Factory default

(**) With FIX-2 code, the higher transducer in value drive the fans regulation

Configuration regulator RDM300 D.S.
Procedure of configuration changing

To change configuration proceed as below specified:

- Press, and keep pressed, button **SB1** (see 2.2);
- Press simultaneously, and keep pressed, buttons: **ENT** and positioned below the display;
- Release button **SB1**;
- Wait until **“Configuration Default Choice”** appear on the display;
- Release simultaneously both **ENT** and ;
- Using or , choose the desired configuration;
- To select the configuration press **ENT**. **“choice default”** will change to **“store default”** and will start ;
- Press and release simultaneously buttons **ENT & ESC** to confirm or press **ESC** to reset the selection and come back to point 6
- Press **ESC** to go back to main menu.

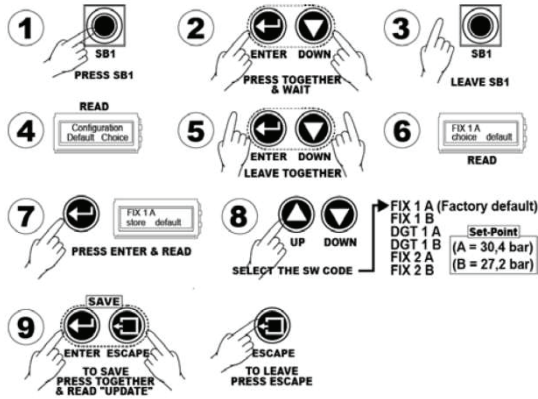

Tab. 1. - Displayed Parameters FIX1 and FIX2

Displayed parameters description		Default Values		
		Set A	Set B	U.M.
in1	Selected Input value (with DGT-1 : value after Digital Scroll filter)	-	-	bar
i1	Input N°1 value	-	-	bar
i2	Input N°2 value (FIX 1 = °C; FIX 2 = bar)	-	-	°C / bar
SP	Set-point (bar)	30.4	27.2	bar
Pb	Proportional Band	7	7	bar
hi	MAX VAC limit	100	100	% RPM
Lo	Upper MIN VAC limit	15	15	% RPM
LL	Lower MIN VAC limit	15	15	% RPM
de	Time of acceleration and deceleration (soft start/stop)	2	2	s
Sh	Bypass MAX limit (input value for which the output is forced to 100%)	32.4	29.2	bar
ih	Hysteresis on the Sh value of the input signal	1.0	1.0	bar
So	Bypass MIN limit point (input value for which the output is forced to 0%)	19.3	16.1	bar
io	hysteresis on the So value	4.1	4.1	bar
to	Ambient temperature switching (from Lo to LL)	7.0	7.0	°C
ES	Emergency Speed	50	50	% RPM
ti	Internal temperature of the unit	-	-	°C

Tab. 2. - Displayed Parameters DGT1

Displayed parameters description		Default Values		
		Set A	Set B	U.M.
in1	Selected Input value (with DGT-1 : value after Digital Scroll filter)	-	-	bar
i1	Input N°1 value	-	-	bar
i2	Input N°2 value (FIX 1 = °C; FIX 2 = bar)	-	-	°C / bar
SP	Set-point (bar)	30.4	27.2	bar
Pb	Proportional Band	7	7	bar
hi	MAX VAC limit	100	100	% RPM
Lo	Upper MIN VAC limit	15	15	% RPM
LL	Lower MIN VAC limit	15	15	% RPM
de	Time of acceleration and deceleration (soft start/stop)	2	2	s
Sh	Bypass MAX limit (input value for which the output is forced to 100%)	32.4	29.2	bar
ih	Hysteresis on the Sh value of the input signal	1.0	1.0	bar
So	Bypass MIN limit point (input value for which the output is forced to 0%)	19.3	16.1	bar
io	hysteresis on the So value	4.1	4.1	bar
to	Ambient temperature switching (from Lo to LL)	7.0	7.0	°C
ES	Emergency Speed	50	50	% RPM
ti	Internal temperature of the unit	-	-	°C

To change parameter value proceed as below:

1. Press simultaneously the **ENT & ESC** buttons;
 2. Pressing \triangle or ∇ , choose the desired configuration;
 3. To select desired parameter press **ENT**. “*Program*” will change to “*Modify*”;
 4. Press \triangle to increase or ∇ to decrease selected parameter;
 5. Press **ENT** to confirm;
 6. to change another parameter repeat the operation starting from point 2,
- A - Press simultaneously parameter **ENT & ESC** to save (“*Update*” will appear on the display),
 B - Press **ESC** to cancel the operation and come back to the main menu.
- N.B.** If after modification regulation have some problems reset the parameter as specified at point 6

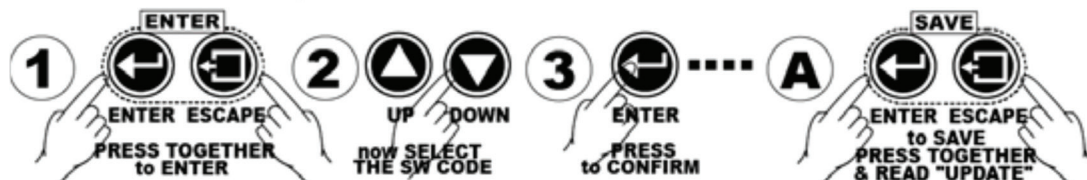

• **FIX-1 mode**

Connection of the 4-20mA transducer for the regulation, and the NTC probe for the MIN speed selection

	CODE	PROBE	SCALE	Code	Sensor	Type	Range
	FIX-1	4-20mA NTC	0-45bar -10T60	FIX-1	Transducer Probe	4-20mA NTC 10kohm	0-45 bar -10÷60°C
	DGT1	4-20mA NTC	0-45bar -10T60				

DGT-1 mode

Connection of the 4-20mA transducer for the regulation, and the NTC probe for the MIN speed selection.

CODE	PROBE	SCALE	Code	Sensor	Type	Range
FIX-1	4-20mA NTC	0-45bar -10T60	DGT-1	Transducer Probe	4-20mA NTC 10kohm	0-45 bar -10÷60°C
DGT1	4-20mA NTC	0-45bar -10T60				

FIX-2 mode

Connection of the 4-20mA transducers for the regulation of two circuits (the higher in value drive the fans).

CODE	PROBE	SCALE	Code	Sensor	Type	Range
FIX-2	4-20mA 4-20mA	0-45bar 0-45bar	FIX-1	Transducer Transducer	4-20mA 4-20mA	0-45 bar 0-45 bar

AUXILIARY contacts

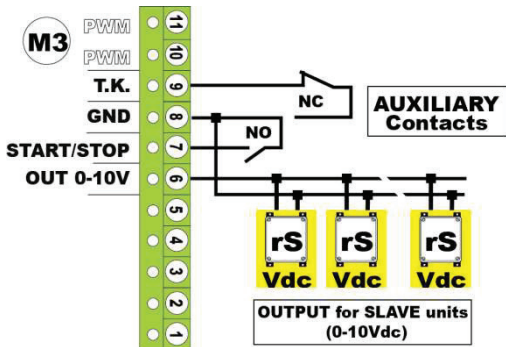

All the contacts of the auxiliary signals and inputs are located on the device M3 terminal block.

Connect to the TK thermal protection to terminals 8 and 9:

- when TK is closed (ON), consent for operation is given;
- when the TK contact is open (OFF) the thermal protection alarm goes off.

Connect the Start/Stop contact (S2) to terminals 7 and 8.

The functioning of the contact depends on the settings of Dsw4



The S2 contact (terminals 7 and 8) does not disconnect the mains power supply: do not use it as a safety switch.

- By using the 0-10 VDC outlet located on the terminal block (terminals 6 and 8), it is possible to control different regulators by means of the same signal.



The VDC control auxiliary output follows the trend of the output voltage (U-V-W) according to the settings of DSw2.

Controller function diagrams

The graph below shows the operating characteristic of the regulator **RDM31248100SR0**.

Proportional mode regulation: adjusts the output voltage to maintain within the proportional band "Pb", the pressure measured by the transducer connected.

The Set Point "SP" is positioned at the upper end of the Proportional Band

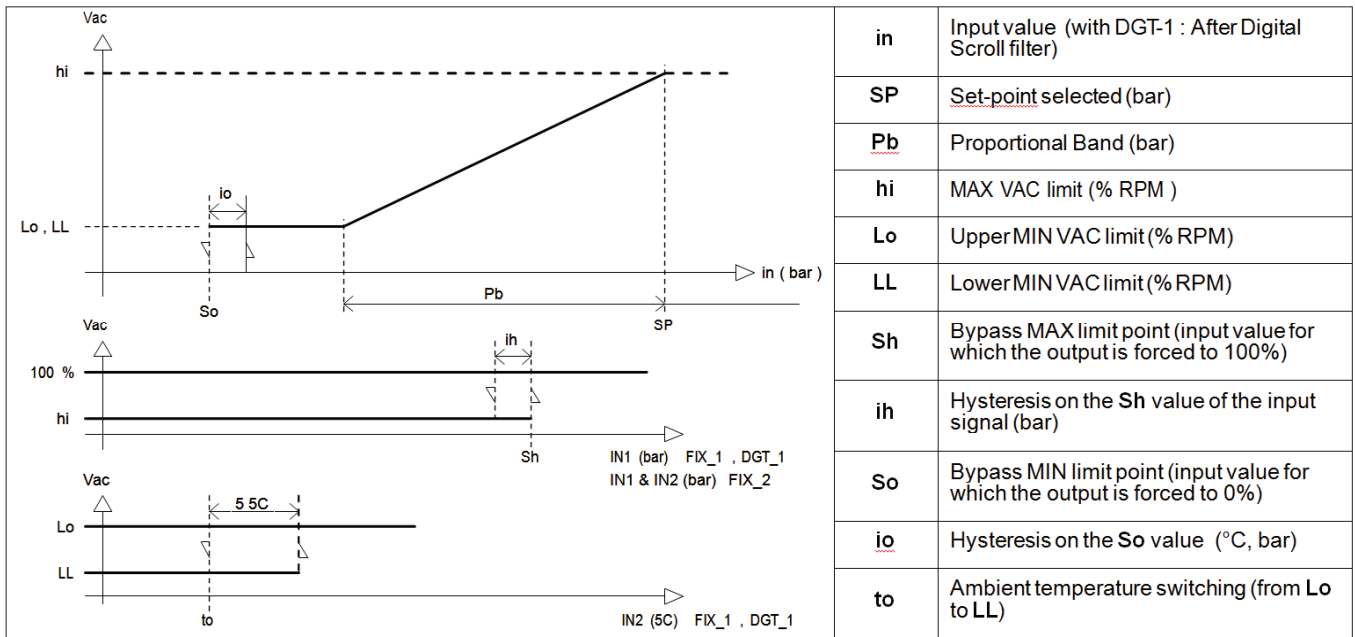

In parallel with the function regulator, acting permanently the following checks:

1. If the instantaneous pressure input IN1 (and/or IN2) exceeds the "Sh" value, the output immediately goes to 100%. It comes under the control characteristic when the input falls below the value "Sh - ih".
Use the unfiltered input signal, regardless of the mode FIX or DGT selected. In the mode DGT the pressure signal is affected by scroll ripple, so you have to take this into account in determining the value of Sh.
2. If the pressure at the input IN1 (and/or IN2) falls below the "So" value, the output immediately goes to 0%. It falls under the control characteristic when the input rises above the "So + io".
3. Only with FIX-1 and DGT-1 if the ambient temperature, measured at the input IN2, is:
 - higher of "to +5°C", the minimum voltage output is "Lo",
 - if it is less than the value "to" the minimum output voltage is "LL".
4. Failure to pressure transducers (the transducer signal leaves the bounds of normal operation if current Iout < 3mA, Iout > 21mA): the fan runs at emergency speed, adjustable from the keypad from 0 to 100%. With # 2 pressure transducers even one transducer fault force insertion emergency speed.

9.3 Controlled by Indoor Unit

9.3.1 Condensing Unit Change Address Procedure

The Control Firmware shall offer the possibility to change the modbus address of one condensing unit which pre-set address is known.

The change address procedure shall be applied in two circumstances:

1. Commissioning of a system with two condensing units, C1 and C2, which are powered through dedicated circuit breaker in the Electric Panel.
2. Replacement of a broken fan from Service with a new one pre-addressed with a known address (e.g. 50).

The procedure number one shall be dedicated to the change of the factory programmed addresses of the fans of the circuit number two, that in origin are identical to the ones of the circuit number one (31, 32, 33, 34).

The Firmware shall have one dedicated page in the Service Menu. The user shall confirm that C1 circuit breaker is **OFF** and C2 is **ON**.

Then the operation shall occur for each fan connected, changing 31 to 41, 32 to 42, 33 to 43, 34 to 44. The user is finally told to do a power cycle of the fans with at least 20 seconds of **OFF** Power to memorize the new addresses.

The replacement of a broken fan with a new one is achieved connecting to fan of address number 50 (the new one installed by service). On connection detection a new page for changing the address shall be open asking for the new address. When it is confirmed the user is finally told to do a power cycle of the fans with at least 20 seconds of **OFF** Power to memorize the new address.

10. Maintenance



NOTICE
 Check the unit regularly and solve the problems as they occur.
 Lack of maintenance could reduce the performance or damage the unit.

10.1 Safety Instructions

Personnel



WARNING
 Only authorized personnel is allowed to do maintenance operations.
 The authorized personnel must be properly trained and qualified, wear appropriate personal protective equipment and use adequate tools.

Electric System



WARNING
 Unit contains potentially lethal voltage in some circuits.
 Risk of arc flash and electric shock.
 Can cause injury or death.

- Open all local and remote unit electric power disconnect switches, verify with a voltmeter that power is **OFF** and wear protective equipment per local standard before working within the electric control enclosure.



WARNING
 The electric connection enclosures, the fan speed control and the EC fan enclosures can retain a stored high-voltage electrical charge for up to **10** minutes.
 Risk of electric shock.
 Can cause serious injury or death.
 Before working within the unit electric connection enclosures or working within the fan speed control and the EC fan enclosures proceed as follows:

- open all local and remote unit electric power disconnect switches
- wait **10** minutes
- verify with a voltmeter that power is **OFF**

Only properly trained and qualified personnel may perform repair, maintenance and cleaning.

Automatic Restart



WARNING
 Fan blades can automatically start rotating without warning at any time during a cooling cycle or after power is restored after a power failure.
 Risk of contact with high-speed, rotating fan blades.
 Can cause serious personal injury or death.
 Before working within the unit cabinet, removing the fan guards or servicing the fan speed control, fan blades or EC fan motors proceed as follows:

- open all local and remote electric power supply disconnect switches
- wait **10** minutes
- verify with a voltmeter that power is **OFF**



WARNING
 This unit operates and restarts automatically.
 The fans may suddenly start blowing out a strong air flow, which may carry particles and small objects from inside the unit.
 Can cause serious personal injury.

- Wear eyes protection when you need to get close to the unit while it is operating.
- Turn the main switch to **OFF** to disconnect the unit from the power supply before any operation on the unit.

Personal Protective Equipment



CAUTION

The microchannel condenser is made of plates and fins, which may have sharp edges and blurr. Always wear cut resistant gloves when operating on the condenser.



CAUTION

Components at high temperature (condenser inlet piping at about 120°C). Always wear temperature resistant gloves when operating on the condenser.

10.2 Safety Labels

- Check regularly that the safety label are still on the unit and clearly visible. See *Annex III – Safety Labels* for safety label mapping. Replace any missing or damaged label.

10.3 Refrigeration System

- Check that the refrigeration pipes are firmly fixed. The refrigeration pipes shall not shake with the vibration of wall, earth or equipment frame. Otherwise reinforce the refrigeration pipes with fasteners.
- Check that there is no oil on the accessories of all refrigeration pipes, and make sure that the pipes do not leak.

10.4 Heat Exchanger

Periodic cleaning can reduce the extent of corrosion and is necessary for the continuous service of MC. In the table below the guidelines for application of MC in different atmospheric corrosivity categories according to ISO 9223:2012 standard:

Tab: 10.1 The guidelines for MC coil coating selection for different atmospheric corrosivity category

Atmospheric corrosivity category (ISO 922)	C1, C2	C3		C4	C5	CX
		Inland	Coastal			
Corrosivity	Very low, Low	Medium	Medium	High	Very High	Extreme
Typical environments-examples	Indoor, Rural areas	Urban areas	Urban areas	Polluted Urban, industrial, coastal areas	Very High pollution & salt deposition areas	Extreme industrial, coastal areas
MC digit 11 = 0	OK	OK	AP	NR	NR	NR
MC digit 11 = E	OK	OK	OK	OK	AP	NR

OK: Recommended;

AP: Acceptable when protection is applied, life may be shortened. Protection could be a additional separating wall or a filter screen;

NR: Not recommended.

The frequency cleaning is depending to the installation area a, but it is suggested to be no less the one indicated on the table below.

Tab: 10.2 Frequency indication for Cleaning Procedures based on different areas

Atmospheric corrosivity category (ISO 922)	C1, C2	C3		C4	C5	CX
		Inland	Coastal			
Corrosivity	Very low, Low	Medium	Medium	High	Very High	Extreme
Typical environments-examples	Indoor, Rural areas	Urban areas	Urban areas	Polluted Urban, industrial, coastal areas	Very High pollution & salt deposition areas	Extreme industrial, coastal areas
Visual inspection	Monthly	Monthly	Monthly	Monthly	Monthly	-
Water Rinse Cleaning	Annually	Once a quarter	Once a quarter	Monthly	Monthly	-
Cleaner Cleaning	Biannually	Biannually	Biannually	Biannually	Biannually	-



NOTICE

Keeping the coil dirty means less performance and risk of corrosion of pipes.



NOTICE

Avoid snow accumulation around the condenser in winter.

10.4.1 Opening the Cleaning Windows

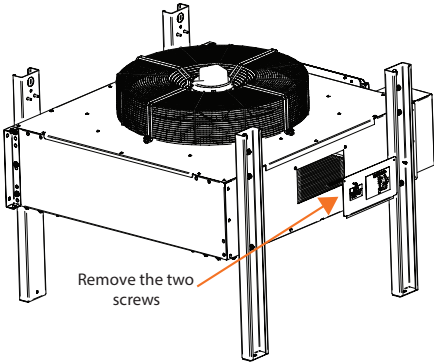

The coil is accessible for cleaning through the innovative cleaning window design, allowing you to clean the coil without removing the fans from the unit.

1. Disconnect the power supply before working on the unit.
2. Remove the cover panels to free the cleaning windows.
3. Loose the mounting screws to open the cleaning windows.

10.4.2 Cleaning

What to use

Plain water Vertiv™ highly recommends to use plain water to clean the coils. Water pressure from a garden hose and sprayer usually works well. If the coil has been maintained and cleaned at regular intervals, water is sufficient to remove dirt and debris from the fins.

Brush You may use a brush to remove heavy build up on the exterior of the fins.

Pressure washer If you use a pressure washer, make sure the equipment is set to a lower pressure setting and that the nozzle is set to the fan spray, not stream. Otherwise, damage to the fins could result.



NOTICE

The recommended flushing water flow is 400 l/hour. Higher water flow would damage the fin of the heat exchanger.

Neutral cleaner If a cleaner is required, it is recommended to use a neutral cleaner.

- Do not use any of the following type of cleaners:
 - acid-type cleaners
 - base-type cleaners
 - sodium hydroxide based cleaners
 - paint solvents (including non-base type)



NOTICE

Using a wrong type of cleaning agents can produce the following effects:

- damage to the coil fins
- damage to the surrounding structure
- loss of refrigerant charge
- property damage in general

The cleaner will spread in the surrounding area.

- Check the cleaner instructions and you use it according to the site environmental regulations.



NOTICE

Many sites do not allow the use of acidic cleaners for environmental reasons.

10.5 Fans

Inspection

- Check whether the fan runs normally

In case of problems such as abnormal noise, vibration and bearing failure: contact **Vertiv™** or an **Vertiv™** authorized service center.

Replacement

- Make reference to the fan manufacturer instructions for transport, handling and mounting the fans.



WARNING

The fans are heavy and mounted at some height.

Use adequate lifting equipment and follow the fan manufacturer instructions for handling.

Control parameters

- In case of fan replacement set the correct parameters on the control before restarting the unit (see 9.1 *Premium Controller* – set ID P01 to “1” and ID P02 as required, then set again ID P01 to “0”. At the end of this operation the display will show the number of fans).

10.6 Controller

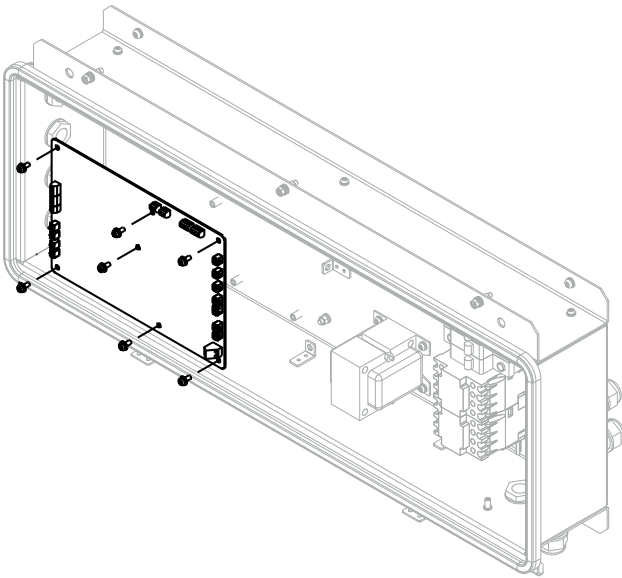

NOTE - If the position of the bolt installation holes on the controller board have changed, please refer to the actual product.

The controller board is installed inside the electrical box.

Check whether the controller operates normally.

If not, replace the controller board.

How to remove

1. Turn the main switch to **OFF** to disconnect the unit from the power supply.
2. Remove the cover plate of electrical control box.
3. Remove all the cables connected with the controller board.
4. Remove the bolts on the controller board, and remove the controller board, as shown in the figure.



NOTICE

Remove only the seven bolts shown in the figure. Do not remove any other bolt from the controller board.

How to reassemble

1. Screw down the bolts to fix the new controller board in the electrical control box.
2. Fix the heat sink by its bolt, note that the heat sink must cling to the bottom plate of the electrical control box.
3. Connect the cables correctly.
4. Update the firmware (see *Annex I – Application Firmware Update*)
5. Restore the cover plate of electrical control box.

11. Troubleshooting

Symptom	Possible Cause	Check or Remedy
Condenser will not start	No power to condenser.	Check voltage at input terminal block.
	Circuit breaker or fuse for low-voltage transformer in condenser is tripped	Locate problem in condenser electrical panel and repair.
	No low-voltage signal to/from indoor unit.	Locate open circuit and repair.
	Missing Modbus communication (only for Controlled Indoor Unit).	Check the cable connection. Check if the fans have the correct addressing.
Low discharge pressure	Faulty head pressure control valve or premium efficiency control board.	Replace if defective.
High discharge pressure	Dirty condenser fins.	Check for low-voltage signal from indoor unit.
	Condenser fans not operating.	Check fan motors and fuses.
	High refrigerant charge	Check refrigerant charge.
Control Board LEDs do not light.	Connection to P24 is loose or disconnected.	Check the connection to P24 to verify that is connected securely. Check the connector from the transformer for loose terminals.
	Fuse located next to P24 has blown	Verify that the fuses next to P24 have not blown. Replace as needed.
	24V transformer has failed.	With a voltmeter verify that the output from the transformer is 24Vac \pm 10%. If the value exceeds \pm 10%, verify that the correct primary leads are being used.
	Premium Efficiency Control Board has failed.	If there is no output voltage, verify that the primary connections are secure and receiving the correct voltage. If they are, replace the transformer.
Fan will not run	Jumper not installed between 24V and DIN1 (for Ziehl-Abegg fan motor).	Install jumper between 24V and DIN1 (for Ziehl Abegg fan motor).

12. Dismantling the unit

The machine has been designed and built to ensure continuous operation.

The working life of some of the main components, such as the fan, depends on the maintenance that they receive.

The machine must be dismantled if it is moved to another site, or at the end of its technical and operational life.



NOTICE

The unit contains substances and components hazardous for the environment (electronic components, lead gel battery, refrigerating gases and oils).

At the end of the useful life, when the unit is dismantled, the operation must be carried out by specialized refrigerating technicians.

The unit must be delivered to suitable centers specialized for the collection and disposal of equipment containing hazardous substances.

The lead gel battery, refrigeration fluid and the lubricating oil inside the circuit must be recovered according to the laws in force in the relevant country.

12.1 Safety Instructions

Personnel



WARNING

Only authorized personnel is allowed to do dismantling operations.

The authorized personnel must be properly trained and qualified, wear appropriate personal protective equipment and use adequate tools.

Electric System



WARNING

Unit contains potentially lethal voltage in some circuits.

Risk of arc flash and electric shock.

Can cause injury or death.

- Open all local and remote unit electric power disconnect switches, verify with a voltmeter that power is **OFF** and wear protective equipment per local standard before working within the electric control enclosure.



WARNING

The electric connection enclosures, the fan speed control and the EC fan enclosures can retain a stored high-voltage electrical charge for up to **10** minutes.

Risk of electric shock.

Can cause serious injury or death.

Before working within the unit electric connection enclosures or working within the fan speed control and the EC fan enclosures proceed as follows:

- open all local and remote unit electric power disconnect switches
- wait **10** minutes
- verify with a voltmeter that power is **OFF**

Only properly trained and qualified personnel may perform repair, maintenance and cleaning.

Personal Protective Equipment





CAUTION

The microchannel condenser is made of plates and fins, which may have sharp edges and blurs.

- Always wear cut resistant gloves when operating on the condenser.

12.2 Operations

Operation	Notes
1. Disconnect the main switch from the electric power supply	Reverse the procedure from chapter 7. <i>Installation:</i>
2. Disconnect the Premium Controller from the main unit	8.6 <i>Electrical Connections</i>
3. Remove the refrigerant	 <p>NOTICE Handle the refrigerant according to regulations about F-Gases and safety data sheet. See 13. <i>Regulation (EU) no. 517/2014 (F- gas)</i></p>
4. Cut the piping at inlet and outlet of the unit	 <p>WARNING Before cutting the pipeline, make sure that the circuit is completely discharged.</p>
5. Remove the fixing bolts	Reverse the procedure from chapter 7.5 <i>Unpacking</i>
6. Move away the unit	See 7.0 <i>Handling</i>
7. If you need to keep the unit in a storehouse for reuse	See 7.3 <i>Storage</i>
8. If you need to scrap the unit	Handle to authorized disposal company according to the local regulations about waste disposal.

13. Regulation (EU) no. 517/2014 (F- gas)

13.1 Introduction

Stationary air conditioners placed into the European Community market and operating with fluorinated greenhouse gases (F-gas, such as R407C, R134a, R410A), have to comply with the F-gas Regulation (EU) No. 517/2014.

This Regulation is in force since Jan 1, 2015 and it replaces the Re. (EU) no. 342/2006.

This document summarizes the obligations for the operators that are responsible for the equipment during all its operative life until its disposal.

13.2 Normative References

F-gas	517/2014	Regulation (EU) No 517/2014 of the European Parliament and of the Council of 16 April 2014 on fluorinated greenhouse gases and repealing Regulation (EC) No 842/2006
Certified personnel and Companies	2015/2067	Commission Implementing Regulation (EU) 2015/2067 of 17 November 2015 establishing, pursuant to Regulation (EU) No 517/2014 of the European Parliament and of the Council, minimum requirements and the conditions for mutual recognition for the certification of natural persons as regards stationary refrigeration, air conditioning and heat pump equipment, and refrigeration units of refrigerated trucks and trailers, containing fluorinated greenhouse gases and for the certification of companies as regards stationary refrigeration, air conditioning and heat pump equipment, containing fluorinated greenhouse gases
Leak check air conditioning	1516/2007	Commission Regulation No 1516/2007 of 19 December 2007 establishing, pursuant to Regulation (EC) No 842/2006 of the European Parliament and of the Council, standard leakage checking requirements for stationary refrigeration, air conditioning and heat pump equipment containing certain fluorinated greenhouse gases
Leak check fire protection systems	1497/2007	Commission Regulation No 1497/2007 of 18 December 2007 establishing, pursuant to Regulation (EC) No 842/2006 of the European Parliament and of the Council, standard leakage checking requirements for stationary fire protection systems containing certain fluorinated greenhouse gases

From 01/01/2017 to be replaced by:

Commission Implementing Regulation (EU) 2015/2068 of 17 November 2015 establishing, pursuant to Regulation (EU) No 517/2014 of the European Parliament and of the Council, the format of labels for products and equipment containing fluorinated greenhouse gases

13.3 Fluorinated Greenhouse Gases

Following notes have to be considered when operating with the above mentioned equipments:

- Fluorinated greenhouse gases are covered by the Kyoto Protocol.
- The fluorinated greenhouse gases in this equipment should not be vented to the atmosphere.
- Referring to the value noted in Annex I and Annex IV of Regulation (EU) No 517/2014 here below the global warming potential (GWP) of some major F- gases or mixtures:
 - R-134a GWP 1430
 - R-407C GWP 1774
 - R-410A GWP 2088

NOTE: the refrigerants as R22 are not F-gas and their relevant regulation is Reg. (EU) no. 1005/2009.

13.4 Operators

13.4.1 Definitions

- Operator, according to Regulation 517/2014 Article 2, point 8, means the natural or legal person exercising actual power over the technical functioning of products and equipment covered by this Regulation.
- The State may, in defined, specific situations, designate the owner as being responsible for the operator's obligations.
- Where large installations are involved, service companies are contracted to carry out maintenance or servicing. In these cases the determination of the operator depends on the contractual and practical arrangements between the parties.

13.4.2 Obligations

Operators of stationary air conditioners, which contain fluorinated greenhouse gases, shall, using all measures which are technically feasible and do not entail disproportionate cost:

- Prevent leakage of these gases and as soon as possible repair any detected leakage.
- Ensure that they are checked for leakage by certified personnel.
- Ensure for putting in place arrangements for the proper recovery by certified personnel.
- According to Regulation 517/2014 the operators shall ensure that the equipment is checked for leaks as following:
 - Case 1** - Non-sealed equipment contains less than 5 tonnes of CO₂ equivalent of fluorinated greenhouse gases.
 - ▶ Leakage test not required
 - Case 2** - Hermetically sealed equipment contains less than 10 tonnes of CO₂ equivalent of fluorinated greenhouse gases.
 - ▶ Leakage test not required
 - Case 3**
 - ▶ **Leakage test required:** check the equipment for leaks with the minimum frequency given in the following table:

X = Tonnes of CO ₂ Equivalent	Y = equivalent amount of refrigerant [kg]			Minimum frequency for leak check	
	R134a	R410A	R407C	without leakage detection	with leakage detection
5 ≤ X < 50	3,5 ≤ Y < 35	2,4 ≤ Y < 24	2,8 ≤ Y < 28	12 Months	24 Months
50 ≤ X < 500	35 ≤ Y < 350	24 ≤ Y < 240	28 ≤ Y < 282	6 Months	12 Months
X ≥ 500	Y ≥ 350	Y ≥ 240	Y ≥ 282	3 Months	6 Months

- Recovery for the purpose of recycling, reclamation or destruction of the fluorinated greenhouse gases, pursuant to Art. 8 of the Regulation 517/2014 shall take place before the final disposal of that equipment and, when appropriate, during its servicing and maintenance.

13.5 Leakage Detection

The manufacturer approves the following leakage check methods according to Reg. 1516/2007 and Reg. 1497/2007:

Method	Specifications
a Check of circuits and components representing a risk of leakage with gas detection devices adapted to the refrigerant in the system	Gas detection devices shall be checked every 12 months to ensure their proper functioning. The sensitivity of portable gas detection devices shall be at least five grams per year.
b Application of ultraviolet (UV) detection fluid or suitable dye in the circuit	The method shall only be undertaken by personnel certified to undertake activities which entail breaking into the refrigeration circuit containing fluorinated greenhouse gases.
c Proprietary bubble solutions/soapsuds	---

13.6 Labelling

The label applied on the unit (see *Onboard Label*) is designed to fill-in the relevant amounts of refrigerant according to Regulation 1494/2007 (2015/2068):

- a** Where fluorinated greenhouse gas is foreseen to be added to the equipment outside of the manufacturing site at the point of installation, a dedicated label accommodates notation of both the quantity [kg] pre-charged in the manufacturing plant and of the quantity charged at the installation site as well as the resulting total quantity of F-gas as a combination of the above mentioned quantities, in a manner which conforms to the legibility and indelibility.

Our split units are usually not pre-charged on factory, in this case the total quantity of refrigerant charged in the unit has to be written in the relevant label, during the commissioning operation at the installation site.

All of the quantities of must be given both as mass of refrigerant [kg] and as Tonnes of CO₂ Equivalent.

Use the following rule for computation:

$$\text{Tonnes of CO}_2 = \frac{\text{kg of refrigerant} \times \text{GWP of refrigerant}}{1000}$$

where:

Refrigerant	GWP
R-134a	1430
R-407C	1774
R-410A	2088

- b** Our packaged units (not split) operating with f-gas are usually full charged on factory and the total amount of refrigerant charge is already reported on the label. In this case, the label has no need of further written information.
- c** In general, the above mentioned information has been located in the main nameplate of relevant unit.
- d** For equipment with double refrigeration circuits, in regards to differentiates requirements on the basis of the quantity of F-gas contained, the required information about refrigerant charge quantities has to be listed separately for each individual circuit
- e** For equipments with separate indoor and outdoor sections connected by refrigerant piping, the label information will be on that part of the equipment which is initially charged with the refrigerant. In case of a split system (separate indoor and outdoor sections) without a factory pre-charge of refrigerant, the mandatory label information will be on that part of the product or equipment which contains the most suitable service points for charging or recovering the fluorinated greenhouse gas(es).

NOTE: *Safety data sheets of F-gases used in the products are available on demand.*

13.7 Record Keeping

Operators of equipment which is required to be checked for leaks (see *13.5 Leakage Detection*), shall establish and maintain records for each piece of such equipment specifying the following information:

- a** the quantity and type of fluorinated greenhouse gases installed
- b** the quantities of fluorinated greenhouse gases added during installation, maintenance or servicing or due to leakage
- c** whether the quantities of installed fluorinated greenhouse gases have been recycled or reclaimed, including the name and address of the recycling or reclamation facility and, where applicable, the certificate number
- d** the quantity of fluorinated greenhouse gases recovered
- e** the identity of the undertaking which installed, serviced, maintained and where applicable repaired or decommissioned the equipment, including, where applicable, the number of its certificate
- f** the dates and results of the leak checks carried out (see *13.5 Leakage Detection*)
- g** if the equipment was decommissioned, the measures taken to recover and dispose of the fluorinated greenhouse gases

Unless the records are stored in a database set up by the competent authorities of the Member States the following rules apply:

- a** the operators shall keep the records for at least five years
- b** undertakings carrying out activities for operators shall keep copies of the records for at least five years

Annex I – Application Firmware Update

NOTE: The configuration of the board is reset to factory defaults after firmware update. The configuration must be manually restored.

How to update the firmware

Update of the condenser board firmware is accomplished using a USB flash drive mounted on the board's USB port (P54). Here are the steps necessary to update firmware.

- Use a USB flash drive. The file system on the flash drive must be formatted for FAT. This is the normal case for most flash drives. Other formats, such as NTFS, will not be recognized by the condenser board.
- The firmware image file must be named '**gcp_app.tar.gz**'. This file must be placed in the root folder of the USB flash drive.
- Ensure that power to the board is **OFF**.
- Connect the flash drive to the board using the USB port (P54).
- Power **ON** the board. The board boot process will be followed.

Boot process

See 8. *Premium Controller - 9.1 Operation Description* for a description of the standard boot process.

- The boot process will be different with the flash drive connected. The LED display will initially show '**888**' until the flash drive is detected.
- Once the flash drive is detected and the firmware image is found in the root folder, about **17** seconds after power on, the LED will begin to alternately display '**U01**' and count down from '**15**'.
- During the count-down period the user is expected to push the '**ENT**' button on the board (SW4). If this button is not pushed then the normal boot-up process is resumed once the count-down reaches **0**.
- The LED now displays a solid '**U02**' to indicate that internal memory is being erased. This operation will take approximately 30 seconds.
- After memory is erased the LED will display a solid '**U03**' and load the firmware from the USB flash drive, about **42** seconds.
- When the update process completes the LED will display '**APP**'. This indicates that the application is starting. Approximately **28** seconds will pass until normal control starts and the LED displays '**F00**' and the condensing pressure value.
- After another **7** seconds there will be an audible click as the alarm or fan contactor switch closes.

The following table summarizes the firmware update process.

Approx. Duration(sec)	Elapsed Time (sec)	LED	LED State	Description
17	17	888	Solid	Boot up period
15	32	U01	Alternating countdown from 15...14...	Waiting for user to push ENT button. If count-down reaches 0 then normal boot up resumes with firmware update.
30	62	U02	Solid	User presses ENT . Internal memory erasing.
42	104	U03	Solid	Firmware updating, reading from USB, writing to internal memory.
28	132	APP	Solid	Firmware update completed, starting application.
7	139	F00	Alternating to display F00 value	Application started, reading sensor values, displaying F00 (condensing pressure). 7 seconds after ' APP ' to ' F00 ' transition until fan or alarm contactor connected (audible click).

Annex II – Dimensions and Weight

MCS 028

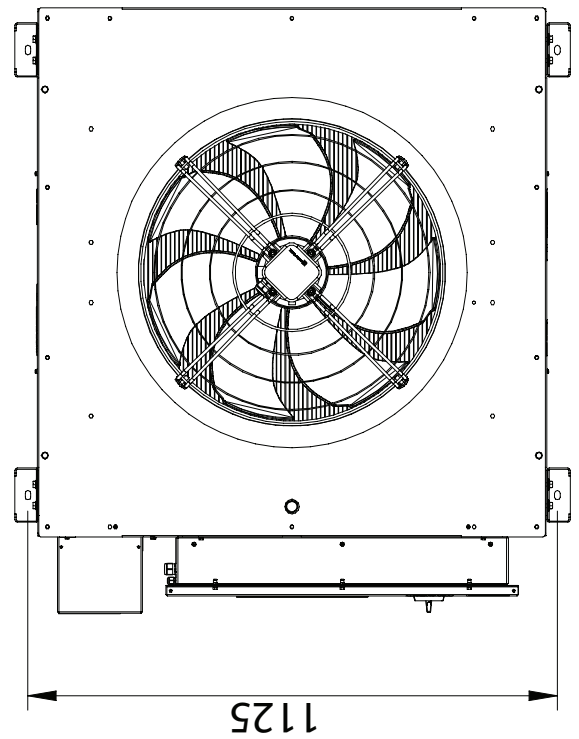
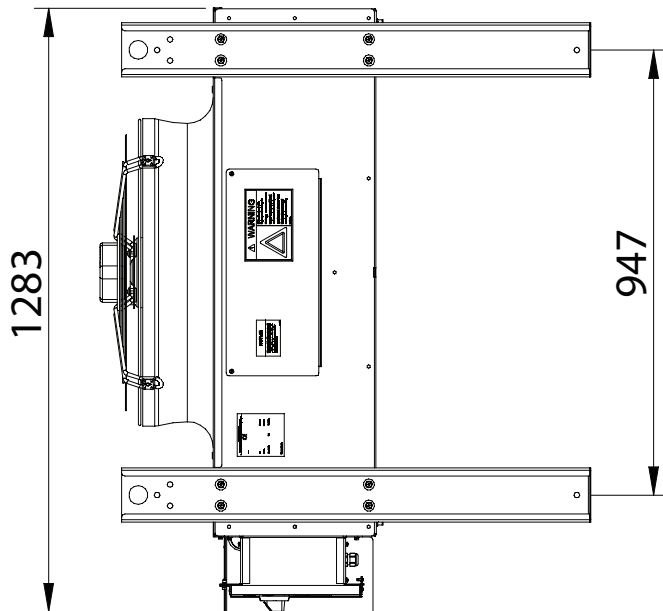
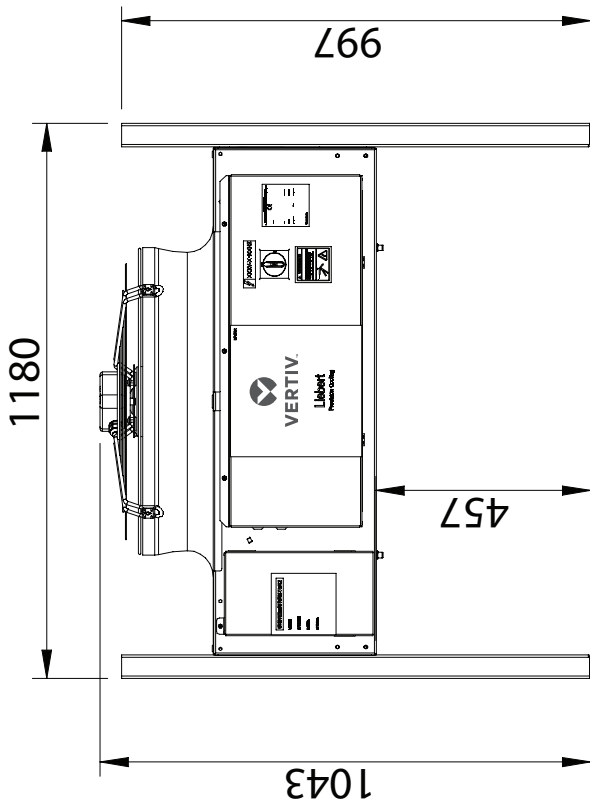

MCM 035

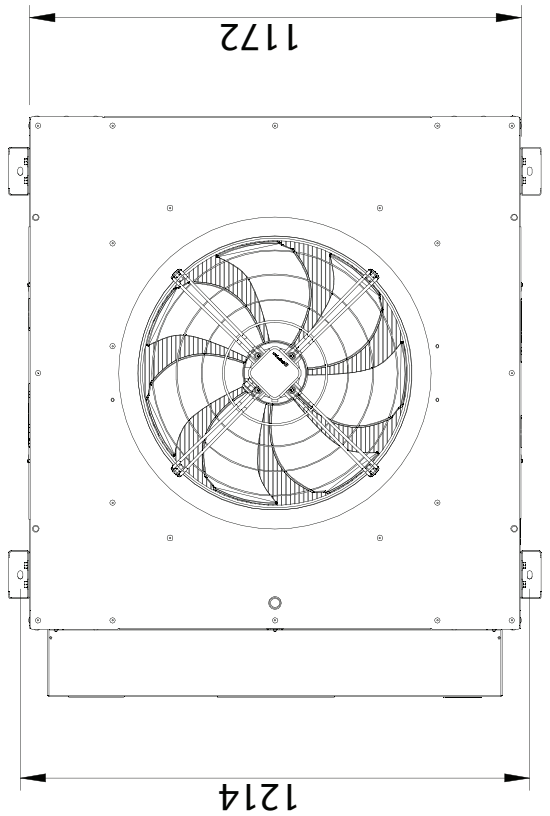
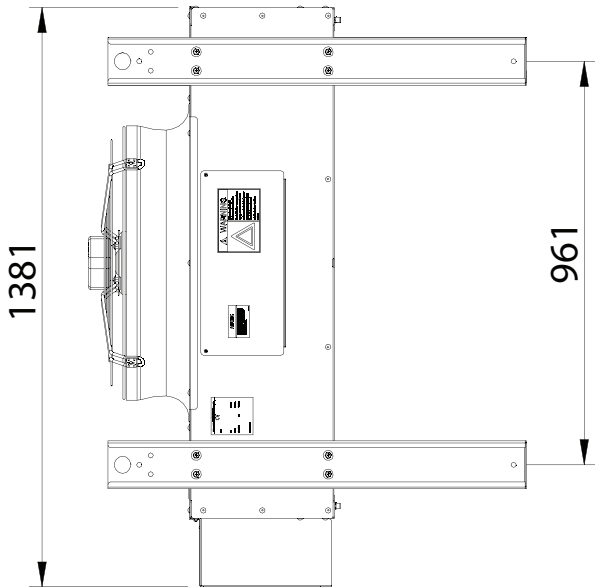
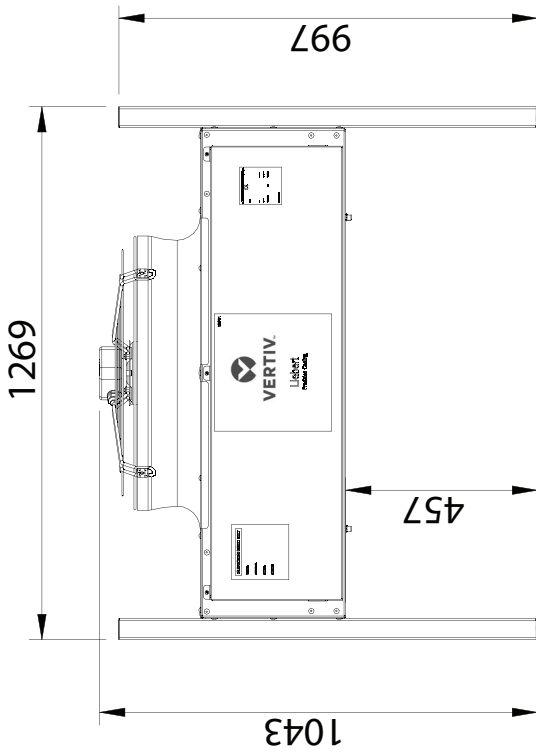

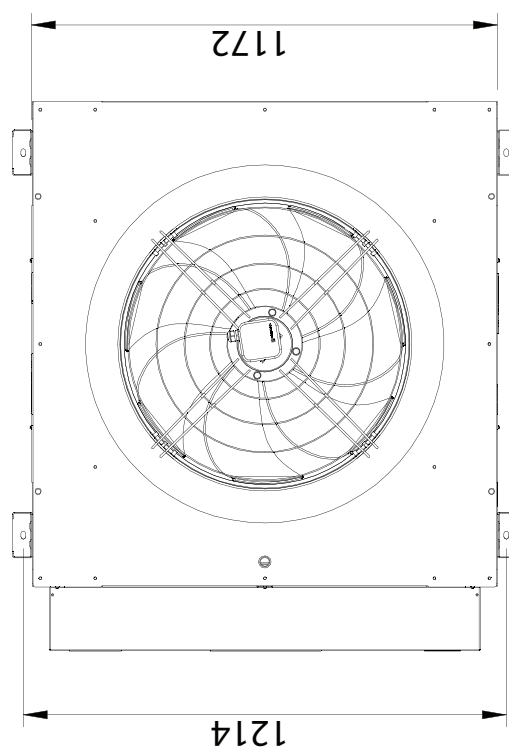
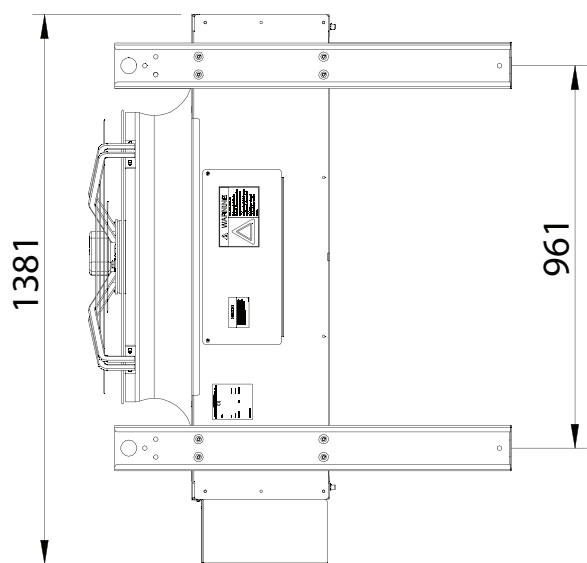
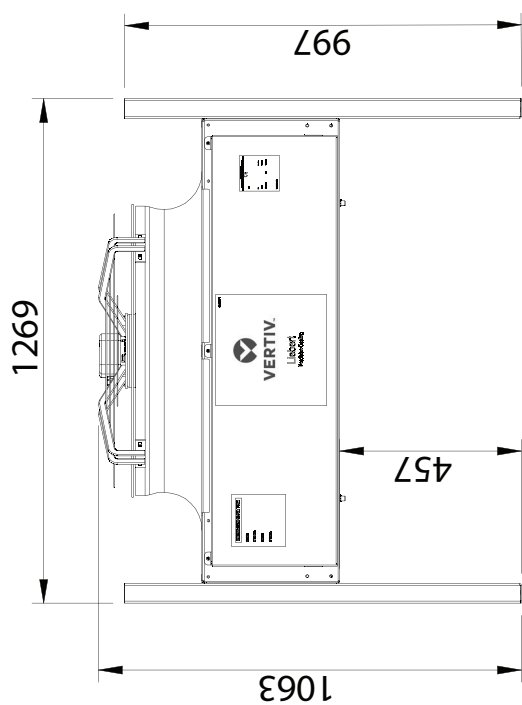

MCL 055

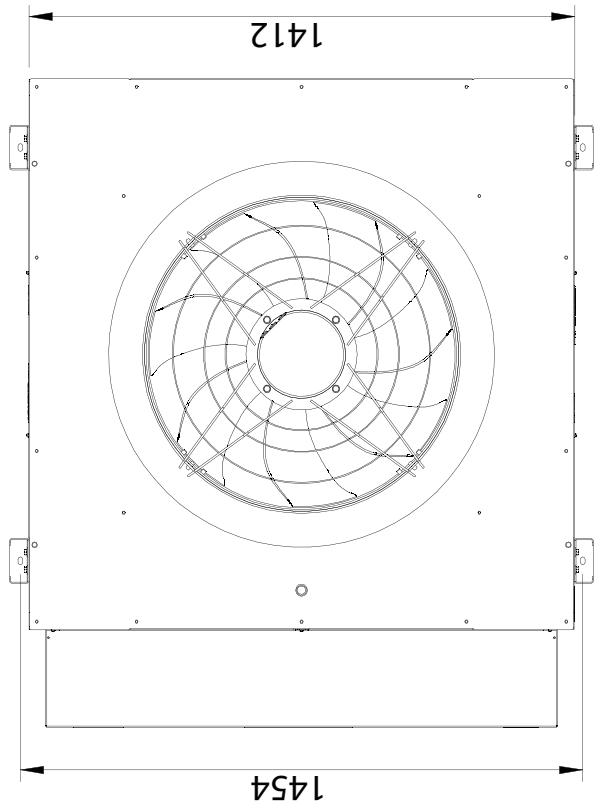
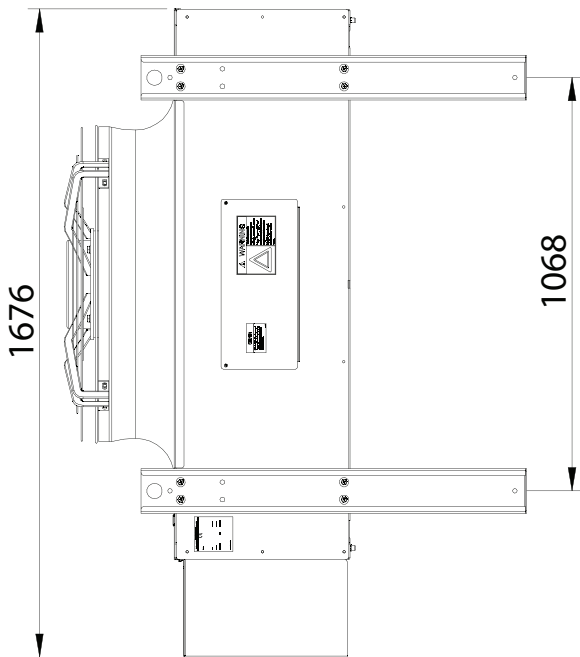
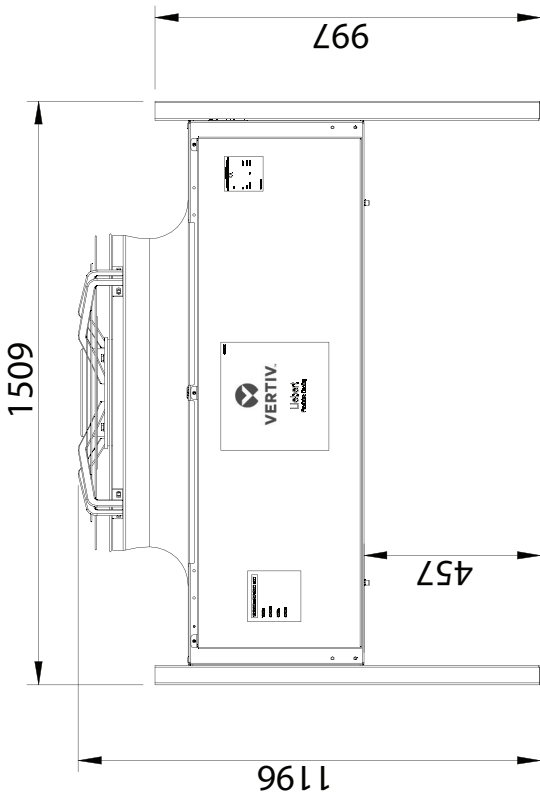

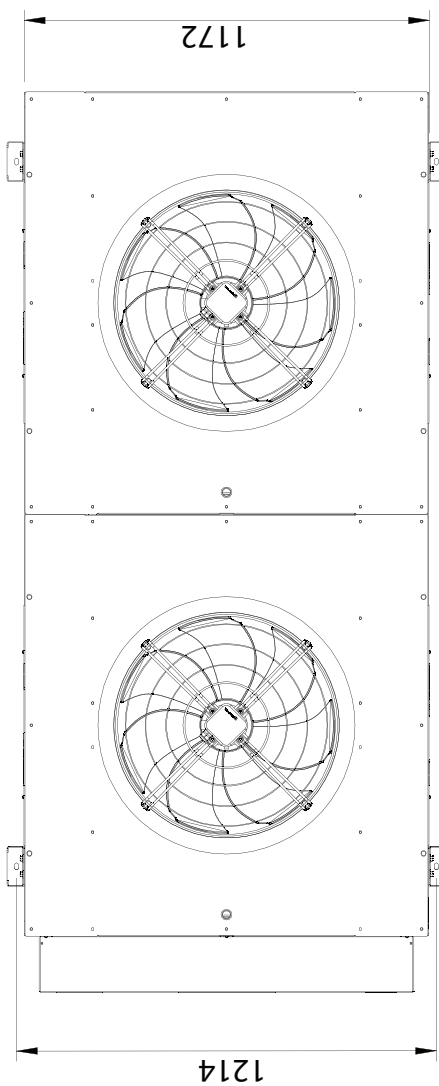
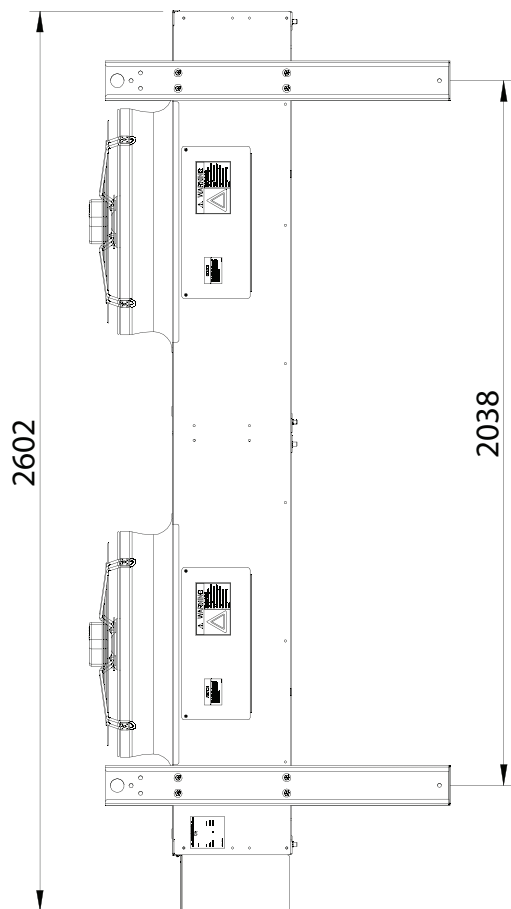
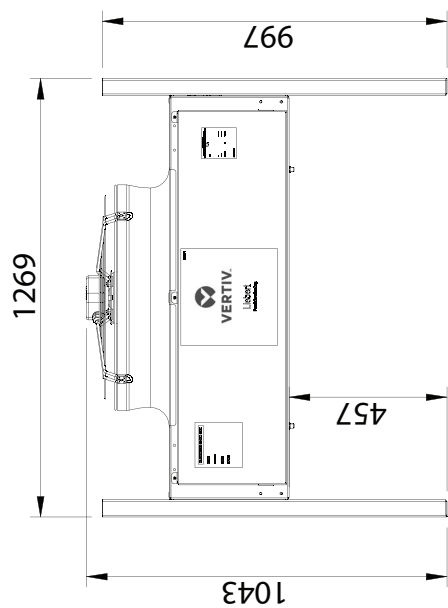

MCM 080

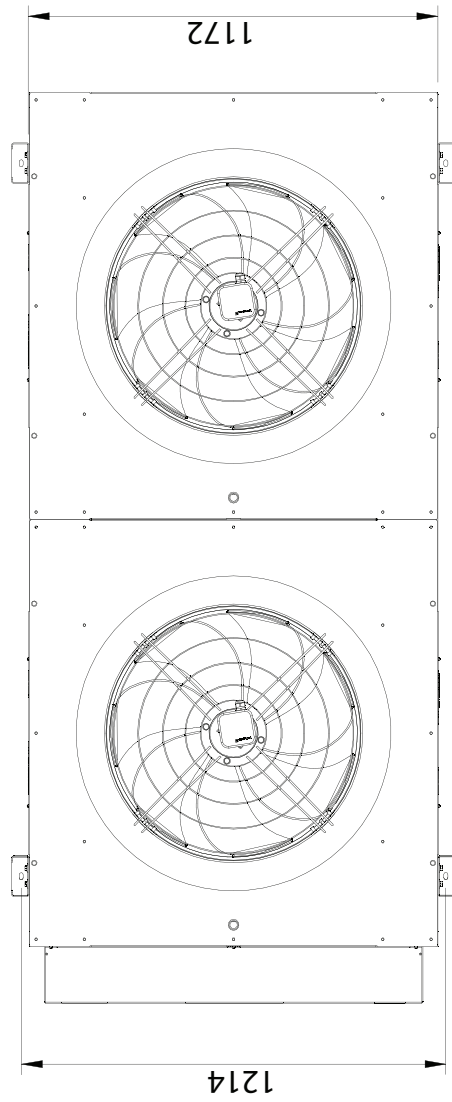
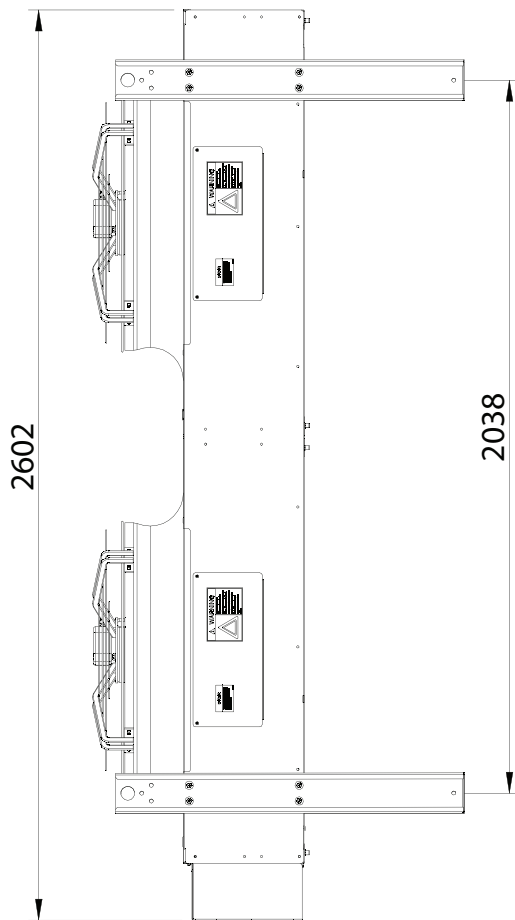
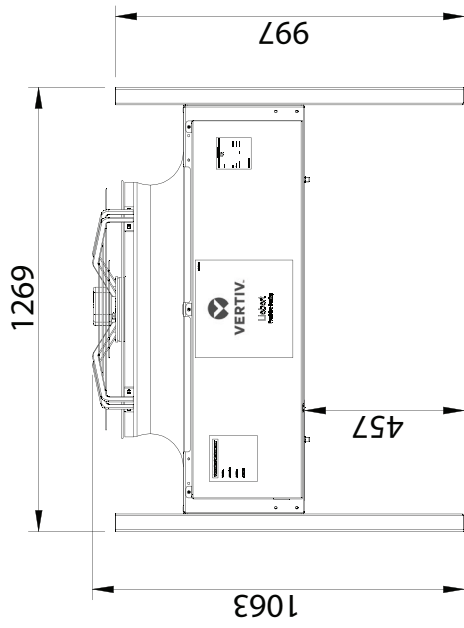

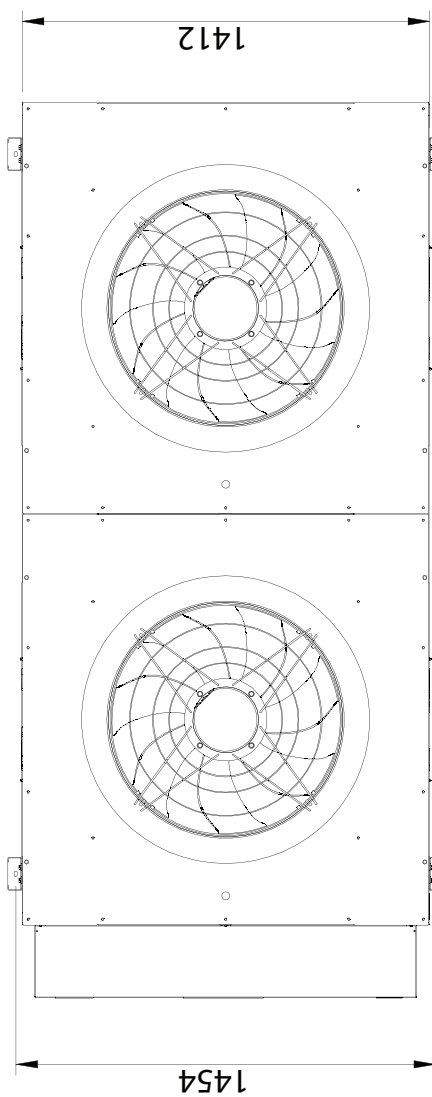
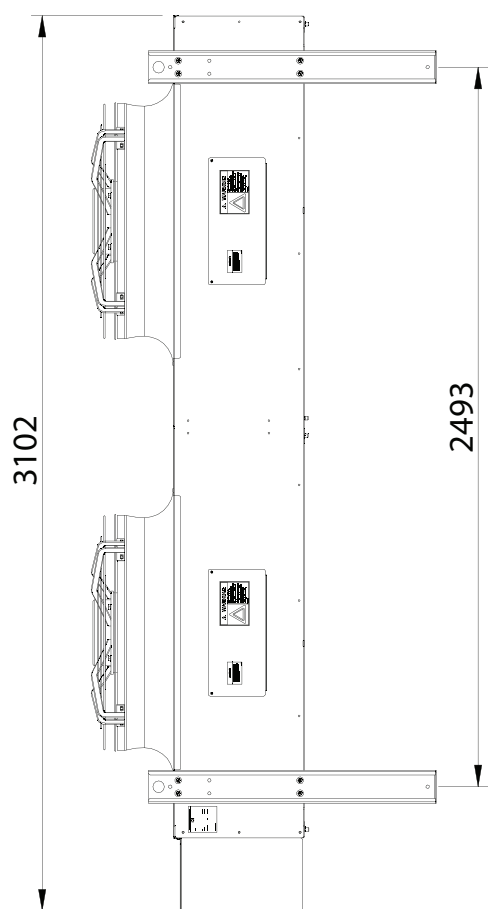
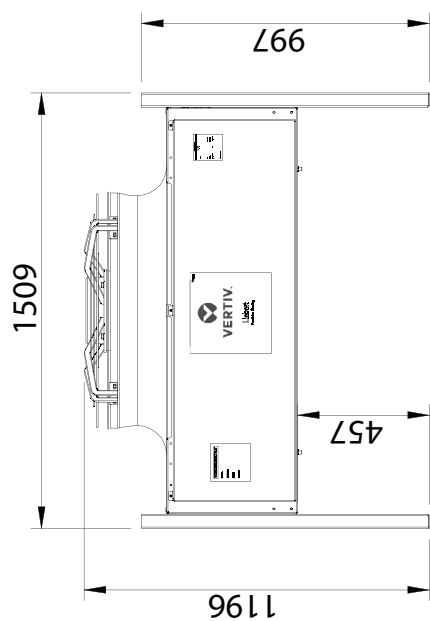

MCM 160

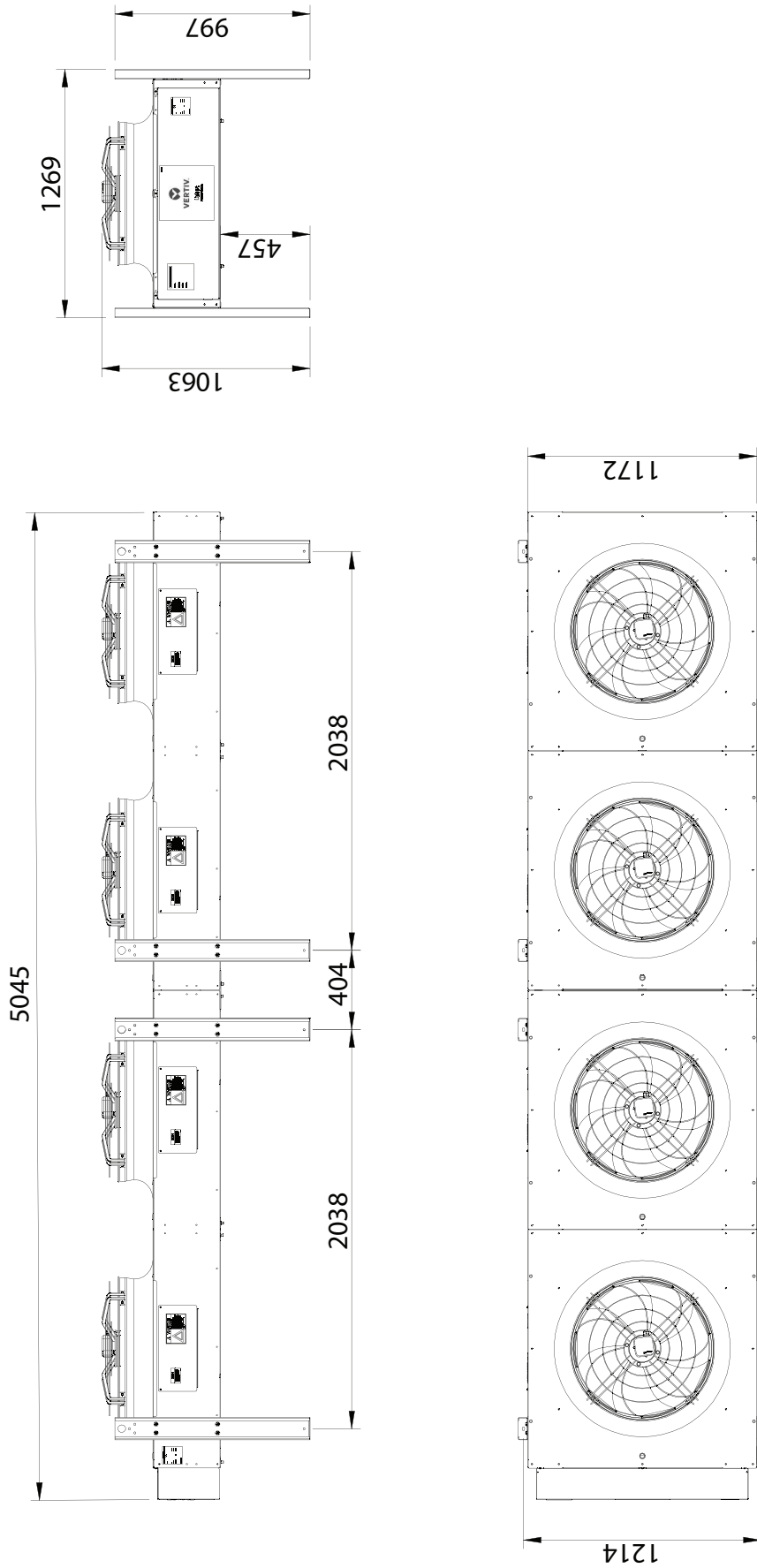

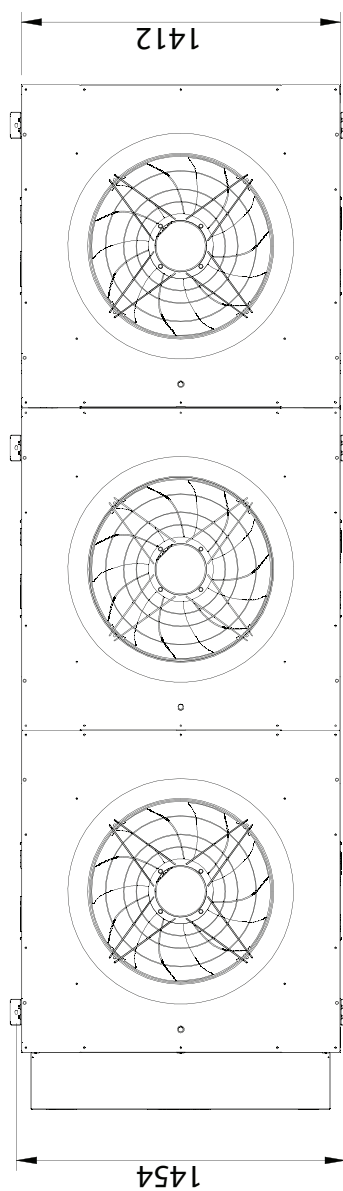
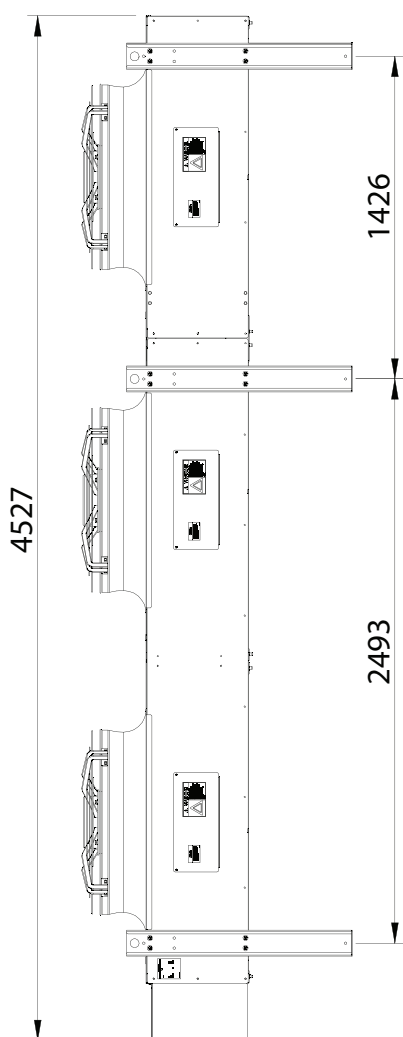
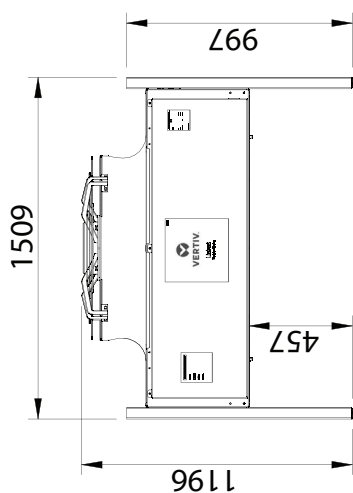

Packaging Dimensions and Weights

Model	Weight (Kg)	Wooden Crate std				Seaworthy packing					
		L (mm)	W (mm)	H (mm)	Packaging weight (kg)	P/N Seaworthy Packing	Drawing Seaworthy Packing	L (mm)	W (mm)	H (mm)	Wood weight (kg) (*)
MCS028	70	1430	1250	1125	46	244582	VC374	1900	1700	1540	165
MCS037	72	1430	1250	1125	46	244582	VC374	1900	1700	1540	165
MSM040	105	1470	1340	1125	48	244582	VC374	1900	1700	1540	165
MCL055	156	1770	1580	1260	57	244582	VC374	1900	1700	1540	165
MCS056	135	2500	1250	1185	63	244583	VC374	3300	1700	1570	285
MCS074	140	2500	1250	1185	63	244583	VC374	3300	1700	1570	285
MCM080	200	2700	1340	1180	66	244583	VC374	3300	1700	1570	285
MCL110	273	3190	1580	1290	78	244583	VC374	3300	1700	1570	285
MCM160	380	5135	1340	1310	170	244585	VC374	5250	1460	1590	355
MCL165	404	4620	1580	1420	160	244584	VC374	4740	1700	1695	385

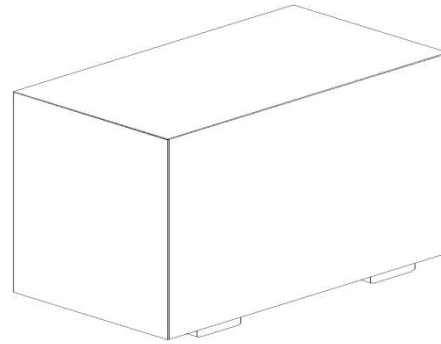
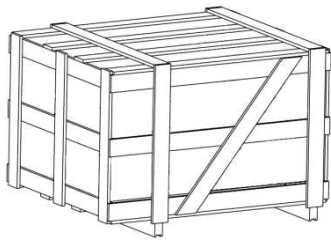

(*) The total weight of the package will be the sum of the std packaging weight and this value.

Annex III – Safety Labels

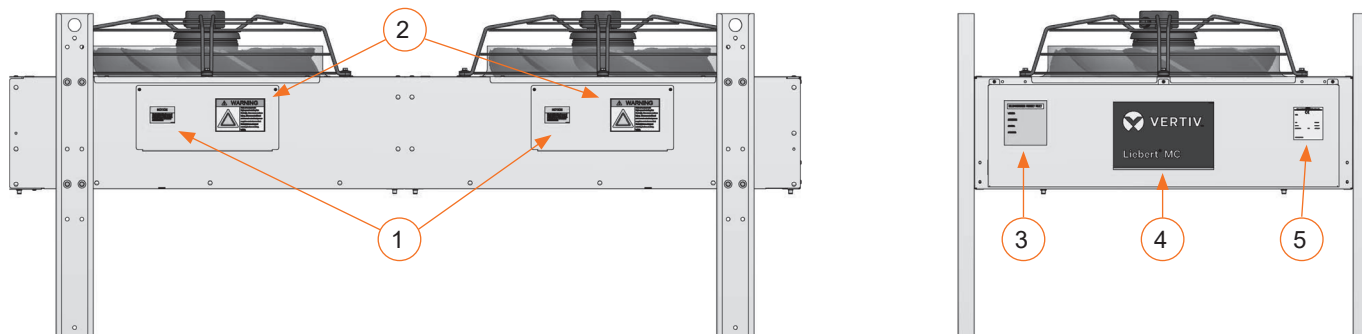

1

NOTICE

Risk of metal dissolving. Can cause coil damage and loss of charge. Do not use acid based cleaner or sodium hydroxide to clean this coil. See user manual for additional information.

2

WARNING

Risk of contact with high-speed rotating blower wheel(s). Can cause injury or death. Disconnect all local and remote electrical power supplies and observe that wheel(s) have stopped rotating before working within.

3

HELIUM/NITROGEN FRIENDLY POLICY

WARNING : REFRIGERATION CIRCUIT PRESSURIZED IN FACTORY WITH DRY HELIUM/NITROGEN. FOR THE FOLLOWING OPERATIONS: DISCHARGING HELIUM/NITROGEN, VACUUMING AND CHARGING THE REFRIGERATION CIRCUIT WITH REFRIGERANT, SEE INSTRUCTIONS IN THE ENCLOSED INSTALLATION MANUAL.

ATTENZIONE : CIRCUITO FRIGORIFERO PRESSURIZZATO IN FABBRICA CON ELIO/AZOTO SECCO. PER LE OPERAZIONI DI SCARICO ELIO/AZOTO SECCO, VUOTO E CARICA REFRIGERANTE DEL CIRCUITO FRIGORIFERO VEDERE ISTRUZIONI SUL MANUALE DI INSTALLAZIONE.

ACHTUNG : DER KÄLTKREIS WURDE IN DER FABRIK MIT HELIUM/TROCKENSTICKSTOFF UNTER DRUCK GESETZT FÜR HELIUM/STICKSTOFFENTLEERUNG, VAKUUM UND KÄLTKREISFÜLLUNG. BITTE IM HANDBUCH NACHSEHEN.

ATTENTION : CIRCUIT DE REFRIGERATION PRESSURISÉ EN USINE AVEC DE HELIUM/L'AZOTE SEC. POUR LE OPERATIONS DE VIDE DE HELIUM/L'AZOTE, VIDE ET REMPLISSAGE DE FRIGORIGÈNE VOIR LES INSTRUCTIONS SUR LA NOTICE D'INSTALLATION.

注意：冷卻系統已注入壓縮乾氦氣，維護工序：排出氦氣，將冷卻系統抽真空及注入所需冷媒，詳情請看附載說明書。

5

Ventiv S.r.l.
Via Leonardo da Vinci, 16118 Sesto: Pieve di Sacco - Padova Italy
Manufactured by VERTIV Slovakia s.r.o. AC Power & Thermal Management, Nowe Mesto Nad Vahou (Slovakia) Plant

CE

MODEL
MCM080/E/P/M/P/E/A/M/X/E/0/0/0/0/0/0/X/0/0/0/\$2U70302

ITEM: **MCM080-8040703** NET WEIGHT: **340 kg**

SERIAL N.
019106880001

SALES ORDER N. **87149713** TYPE **ORD_INTERCO_HUB_SK** LINE NUMBER **3**

MANUFACTURING DATE **SEP 2019** **1** OUT OF **1**

SCHEDULE SHIP DATE **16-SEP-2019**

POS.	DESCRIPTION
1	Label Notice for MC Coil Cleaning
2	Label Warning High Speed Blower wheel(s)
3	Label Warning Helium/Nitrogen
4	Label VERTIV™ Liebert® MC
5	Dataplate with Serial Number and Model



Fabbricante - Manufacturer - Hersteller - Fabricant - Fabricante Fabricante - Tillverkare - Fabrikant - Valmistaja - Produsent Fabrikant
- Κατασκευαστής - Producent
Vertiv S.r.l. - Zona Industriale Tognana
Via Leonardo da Vinci, 16/18 - 35028 Piove di Sacco - Padova (Italy)

Il Fabbricante dichiara che questo prodotto è conforme alle direttive Europee:

The Manufacturer hereby declares that this product conforms to the European Union directives:

Der Hersteller erklärt hiermit, dass dieses Produkt den Anforderungen der Europäischen Richtlinien gerecht wird: Le Fabricant déclare que ce produit est conforme aux directives Européennes:

El Fabricante declara que este producto es conforme a las directivas Europeas:

O Fabricante declara que este produto está em conformidade com as directivas Europeias: Tillverkare försäkrar härmed att denna produkt överensstämmer med Europeiska Unionens direktiv: De Fabrikant verklaart dat dit produkt conform de Europese richtlijnen is:

Vaimistaja vakuuttaa täten, että tämä tuote täyttää seuraavien EU-direktiivien vaatimukset: Produsent erklærer herved at dette produktet er i samsvar med EU-direktiver:

Fabrikant erklærer herved, at dette produkt opfylder kravene i EU direktiverne:

Ο Κατασκευαστής δηλώνει ότι το παρόν προϊόν είναι Αποσχετισμένο σύμφωνα με τις οδηγίες της Ε.Ε.:

2006/42/EC; 2014/30/EU; 2014/35/EU; 2014/68/EU; 2011/65/EU; EU/2015/863



VertivCo.com | Vertiv - EMEA, via Leonardo Da Vinci 16/18, Zona Industriale Tognana, 35028 Piove di Sacco (PD) Italy, Tel: +39 049 9719 111, Fax: +39 049 5841 257

© 2021 Vertiv Co. All rights reserved. Vertiv, the Vertiv logo and Vertiv Liebert MC are trademarks or registered trademarks of Vertiv Co. All other names and logos referred to are trade names, trademarks or registered trademarks of their respective owners. While every precaution has been taken to ensure accuracy and completeness herein, Vertiv Co. assumes no responsibility, and disclaims all liability, for damages resulting from use of this information or for any errors or omissions. Specifications are subject to change without notice.