



Liebert[®] HPM-S

5-30 kW Indoor Room Cooling Units A/W

Product Documentation
English, 273492, rev. 03.04.2024

Introduction

Liebert® HPM-S

Liebert® HPM-S is the new serie of air conditioners developed by Vertiv to allow maximum flexibility of application in technological environments, from data processing centers to manned control rooms and electronic centers for telecommunication. This series includes units with a rated cooling capacity ranging from 5 to 30 kW.

Complete environmental control and reliability are paramount to ensure faultless operation of computer rooms, telecom installations, data centres and technical applications. Vertiv™ products have traditionally set the industry standards. But today's world requires more than just environmental control and reliability; it requires increasingly higher levels of overall performances.

While still offering unmatched environmental control and reliability, the new **Liebert® HPM-S** range raises the bar of performance in Precision Air Conditioning setting new standards in terms of Energy Efficiency, Compactness and Sound emissions.

The new **Liebert® HPM-S** range is available in a number of airflow versions: with upflow, downflow and displacement airflow patterns across a full range of cooling modes: direct expansion, chilled water, freecooling, dual fluid and constant (for an ultra high temperature and humidity control and air filtration).



Under



Over

Features and Benefit

The New Liebert® HPM-S

The plug fan technology with generously dimensioned heat exchanger, scroll compressors and optimised cooling circuits, maximise efficiency by operating at low levels of energy consumption.

This can be further enhanced by the use of Electronically Commutated Fans (**EC Fan**) reducing power input by 35% compared to standard fan technology.

We underline the complete range with all models in Displacement version and in Constant configuration.

The down-flow version achieves the highest levels of efficiency (EER is 20% better than industry average). The fan in this case is positioned upstream of the evaporator optimising airflow over the coil. Also in the Under versions, silencer cartridges can be used to further reduce the sound pressure level by up to a 5 dBA.

The new **Liebert® HPM-S** Digital range equipped with “Digital” Scroll compressor and the electric expansion valve drive through a precise watching between load and cooling capacity.

The new **Liebert® HPM-S** has been designed to have the smallest possible overall footprint. The compactness of the unit is fully evident for some capacities. For instance:

- in the smaller sizes (S0F) where the air outlet plenum is integrated in the unit body in a depth of only 400 mm;
- in the S2G, where 23 kW in direct expansion mode have been reached with footprint of 750 x 750 mm;

Low sound levels are the result of fan design, optimised airflows and doubled skin insulated panels.

Attention to design detail means low operational costs including product maintenance through high levels of reliability and a service friendly design. As an example, all the crucial parts of the refrigeration circuit (i.e.: thermostatic valves, sight glasses and liquid line driers) are grouped together and accessible simply by opening the front door.

Energy Efficiency

EC Fan (Plug-in Electronically Commutated Fan), EC fan Light

Liebert® HPM-S units are supplied with an exclusive fan type, this enables you to greatly increase the unit's efficiency and therefore significantly reduce operating costs.

EC fans [Electronically Commutated DC motors] have the added advantage of higher fan shaft motor efficiency: from 45% of 1-phase motors, to 65% of 3-phase motors and to 85-90% of EC fans.

Additional benefits are that, on start up, the **Liebert® HPM-S** peak inrush current is lower than the operating current. This means the EC fan option features a true soft start. Also compared to AC fan supplied by the frequency converter, the advantages are evident and the input power is clearly inferior: from 13 to 38% as a function of the working point.

The internal electronics of the EC fan are integrated into Vertiv™ controls.

The EC fan design allows a new approach in regulating environmental parameters within HPAC applications. To name a few:

- constant air volume
- constant external static pressure
- sound emission optimisation
- power input optimisation
- cooling capacity regulation (on request)

This enables each system to be optimized for the installation.

These features are available from standard **Liebert® HPM-S** units supplied with the EC fan option and we can summarize that with two words: versatility and efficiency.



EC Fan

Liebert® HPM-S fitted with EC Fan allows a perfect coupling in terms of airflow for each of the sites needs. A full 0,1V adaptation can be done through iCOM™ control.

Furthermore on the units where it is allowed a full set of speed controls is available:

- **Parallel mode:** reducing fans speed according to the room temperature decreasing it proportionally the cooling capacity.
- **ECO mode:** keep the minimum allowed fan speed for the longest part of the proportional band, increasing in advance the cooling control device.
- **Delta mode:** keep constant a temperature difference between 2 sensors installed where the application needs.

Liebert® HPM-S with EC Fan full is offering the full advantages of EC fan technology, adding to the benefits in terms of noise, availability and efficiency the most advanced solutions in terms of control.

Heat Exchanger Section: Net Sensible Capacity matters

Efficiency is a fundamental requirement in all applications today. Even more so for technological applications where the operational costs are by far the most significant consideration. Sensible Heat Ratio (**SHR**) values of greater than 0.90 are required to reduce to a minimum the energy spent controlling humidity during normal operating conditions.

Heat exchanger design and a correct air distribution within the unit are two of the most important factors required to achieve optimum performance.

Liebert® HPM-S units feature a very high coil heat exchanger surface respect the exchanged power.

Using the index [frontal Surface x Rows / refrigeration Power] values of over 100 mm²/W are obtained.

Sophisticated design and development tools, such as Particle Image Velocimetry and Computational Fluid Dynamics are used by Vertiv™ to identify the best components layout in order to achieve an even and pressure-equalised airflow distribution within the unit which optimises the entire coil surface area in the heat exchanging process.

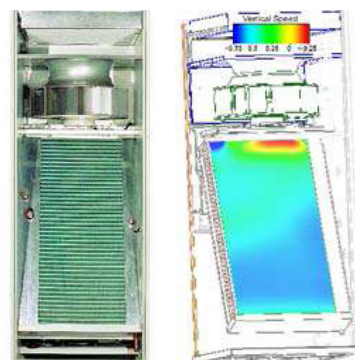

Study of the components of the vector velocity through the coil: vertical speed

Easy maintenance

All components are easily accessible from the front of the room unit.

The service compartment facilitates checking and setting of refrigeration circuit, without changing aerodynamic conditions.

The access to the compressor is possible even when the unit is operating by removing the front panel. The access to the fan is executed with the greatest care for easier interventions (maintenance and/or fan replacement).

One very important feature, for example, is the possibility to check the total pressure drop of the high pressure piping using the Schrader connections available in the front part of the machine (see beside).

Liebert® HPM-S front view

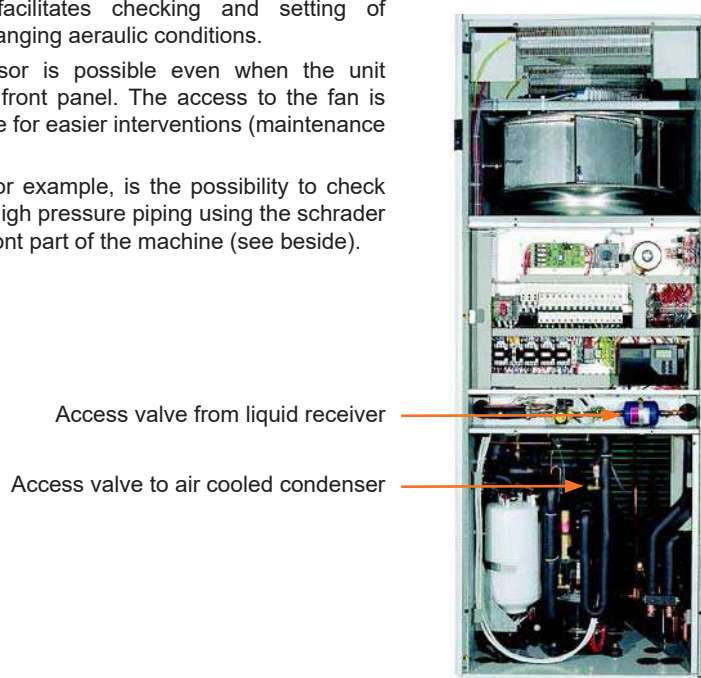

Model Configuration

Digit Nomenclature

The unit is fully defined by seventeen digits.



S 1 E U A

Digit 1

Family

S - Small

Digit 2 and 3

Size: Cooling capacity
"kW" (approx.)

Tens of kilowatt

Digit 5

Version

A - Air Cooled

W - Water Cooled

Digit 4

Air distribution

U - Downflow

O - Upflow

D - Displacement

G - Frontal Upflow

Other Configurations

K - Constant (Upflow only)

L - Constant (Top Frontal Flow only)

Digit 6 - Fan

1 - EC Fan Full

Digit 7 - Main Power Supply

0 - 400V / 3ph / 50 Hz + N

2 - supply 230 V / 1ph / 50 Hz

Digit 8 - Electric Heating

1 - Electric Heating

0 - None

Digit 9 - Humidification

0 - None

V - Electrode Humidifier

Digit 10 - Microprocessor Control

N - iCOM3 & No Display temperature and humidity control

S - iCOM3 & 4.3" Display temperature and humidity control

E - iCOM3 & 7" Display temperature and humidity control

Digit 11 - Reheating System

0 - None

G - Hot gas coil

W - Hot water coil

Digit 12 - Air Filter Efficiency

0 - Coarse 60% gravimetric

1 - ePM10 50% dust spot

2 - Coarse 60% gravimetric + Clogged Filter

3 - ePM10 50% dust spot + Clogged Filter

Digit 13 - Expansion Valve TXV

0 - R410A

Digit 14 - Colour

2 - Black Vertiv™ RAL 7021

Digit 15 - Onboard MCB for Remote Condenser

0 - None

1 - 6A single ph

2 - 10A single ph

Digit 16 - Packing

F - PLP and Pallet

G - PLP and Wooden Crate

M - Seaworthy

Digit 17 - Special Requirements

0 - Standard Vertiv™

X - Special Vertiv™

Air Distribution (4° Digit)

All units are available in the four configurations shown below.

U / UNDER
Downflow

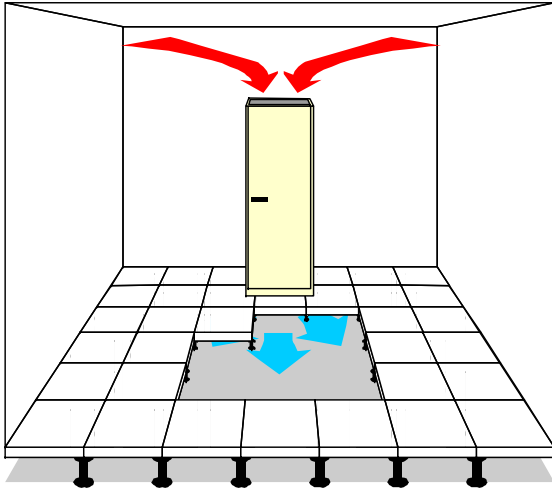

O / OVER
Upflow with front air return

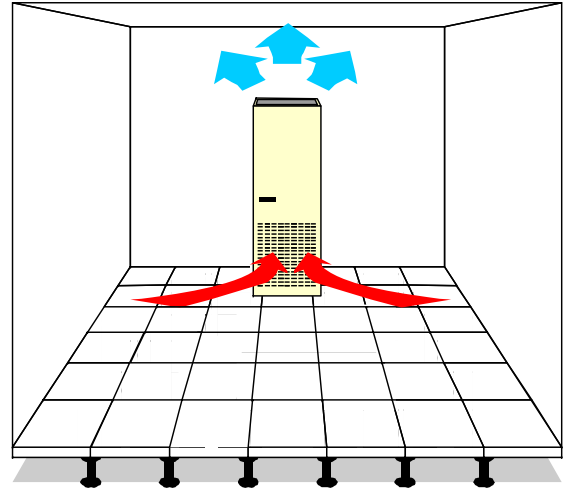

D / DISPLACEMENT
Frontal air discharge at floor level

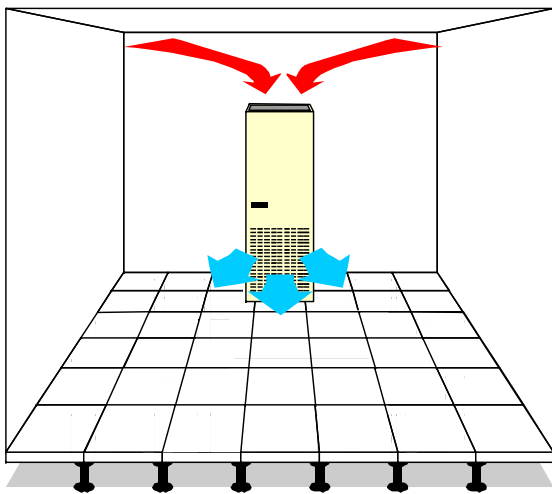

G / GRILL
Frontal upflow with front air return

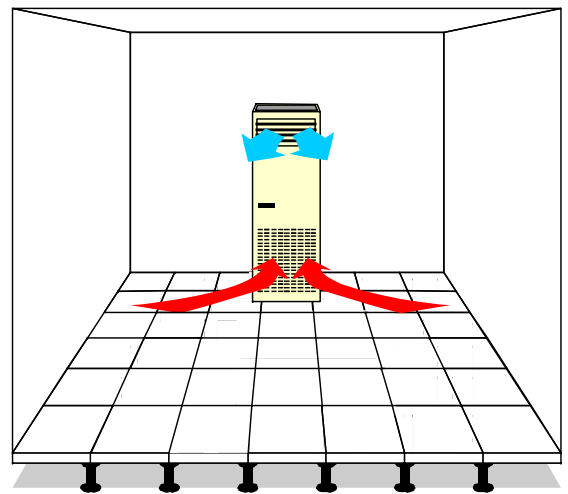

S06 model

Versions (5° Digit) Version A

Direct expansion units with air-cooled condenser Refrigeration circuit

All models are provided with a single refrigeration circuit, **M** and **L** ranges present also double circuit units. The compressor (1) pumps the hot gaseous refrigerant into an outdoor air-cooled condenser (2). The liquefied refrigerant arrives to a liquid receiver (3) that ensures a constant and even refrigerant flow to the thermostatic expansion valve (4) and then arrives to the evaporator (5). Here the refrigerant, thanks to the heat-exchanged with the roomair moved by the fan (6) evaporates and returns to the compressor (1); from this, the refrigerant begins a new refrigeration cycle. To maintain the correct refrigerant discharge pressure, the speed of the motor fan (8) is controlled (ON-OFF or proportional mode).

Shut-off valves are provided as standard to assist with routine maintenance.

The compressor (1) has a built-in non-return valve to avoid return of liquid refrigerant from the condenser in summertime, thus protecting the compressor from undesired refrigerant slugging during the start up. A second non-return valve (7) is recommended to avoid - in wintertime - refrigerant migration from the liquid pipes and the receiver (3) to the condenser (2), that should be responsible of low pressure intervention at the start-up of compressor.

For safety reason, a relief valve (9) is installed on the liquid receiver (3); this valve is equipped with flanged connections so that the refrigerant may be discharged to the outside.

External air-cooled condenser (2)

The units may be connected with a wide range of our condensers in standard or low noise version.

For technical data and performance, refer to the relevant technical documentation *Chap. 5* gives the recommended matching condenser for **Liebert® HPM-S** units as a function of outdoor air temperature.

Note 1. Units and external condensers are supplied separately.

Note 2. The room unit refrigeration circuit is pressurised with helium at 3 bar and the condenser refrigeration circuit at 2 bar with dry air.

Note 3. The customer is responsible for making connections between the Unit and the external condenser and for charging with refrigerant (standard R410A) and oil, when request.

Full instructions for these operations are given in the Service Manual.

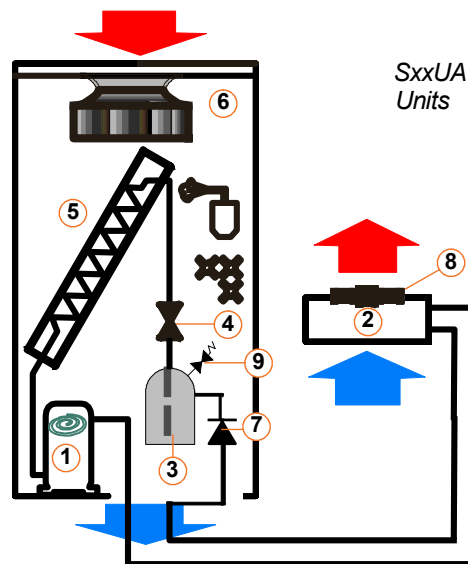

SxxUA
Units

Version W

Direct expansion units with water-cooled condenser Refrigeration circuit

All models are provided with a single refrigeration circuit, **M** and **L** ranges present also double circuit units. The compressor (1) pumps the hot gaseous refrigerant into a water-cooled condenser (2).

The liquefied refrigerant arrives to a liquid receiver (3) that ensures a constant and even refrigerant flow to the thermostatic expansion valve (4) and then arrives to the evaporator (5). Here the refrigerant, thanks to the heat-exchanged with the room air moved by the fan (6) evaporates and returns to the compressor (1); from this, the refrigerant begins a new refrigeration cycle.

Shut-off valves are provided as standard to assist with routine maintenance.

The compressor (1) has a built-in non-return valve to avoid return of liquid refrigerant from the condenser, thus protecting the compressor from undesirable refrigerant slugging during the start-up. A second non-return valve (7) is recommended to avoid refrigerant migration from the liquid pipes and the receiver (3) to the condenser (2), that should be responsible of high pressure intervention at the start-up of compressor.

For safety reason, a relief valve (9) is installed on the liquid receiver (3); this valve is equipped with flanged connections so that the refrigerant may be discharged to the outside.

Water-cooled condenser

These units are provided with one very efficient stainless steel brazed-plate water-cooled condenser (2). The condenser is fitted with an head-pressure regulating valve (8) for the automatic control of condensing pressure.

The units operate with mainswater or closed circuit with an external Dry Cooler. When operating in a closed circuit, to avoid undesired ice formation in wintertime, it is advisable to use water/glycol mixture: refer to *Chap. 5* for the percentages to be used at minimum ambient temperatures. Dry Coolers are available as an option; water-glycol mixture and circulation pump(s) are normally supplied by others.

If mains water is used, a mechanical filter must be fitted in the water circuit to protect the plate condenser (2) (for other information see the Service Manual).

To reduce water and energy consumption (pump), it's advisable to adopt a cooling water control valve (by the user), able to stop water feeding when unit is OFF.

Unit microprocessor control gives a 24V contact (10VA max, please refer to the relevant Wiring Diagram, 58 and G terminals) to drive that valve.

Note. The water-cooled Liebert® HPM-S versions are filled with the complete charge of the requested refrigerant (standard R410A).

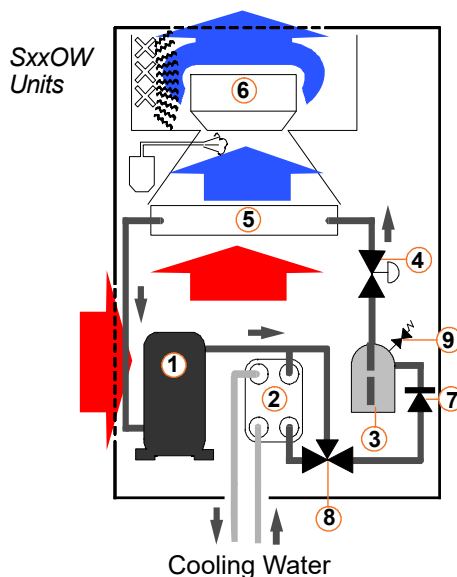

Other Configurations (4° Digit)

CONSTANT

Liebert® HPM-S Constant is the solution for systems requiring extremely precise control of temperature and humidity for the most demanding installations and stringent standards. Typical installations are metrological rooms, laboratories, tobacco, paper and precision mechanical industries.

A special hot gas coil and a modulating valve enable the reduction of cooling capacity. Liebert HPM Constant, with ducted air delivery, allows to maintain temperature and humidity tolerances of $\pm 0.3^{\circ}\text{C}$ and $\pm 2\% \text{R.H.}$ respect the set value. The possible offset ($\pm 0.5^{\circ}\text{C}$) of the precise probes must be taken into consideration and it could be deleted with the relevant parameter control setting.

This important result is achieved through an accurate and continuous variation of both cooling capacity and steam production and fulfilling certain conditions:

1. Minimum thermal load not less than 30% of nominal unit capacity;
2. Stable thermal load or with variations not bigger than 10% per hour;
3. Unit installed and ducted in proper way;
4. Environment with proper thermal insulation from external thermal load (take care of windows, doors, full-length windows etc.);
5. Unit return air conditions within the limits listed in the table below:

Return air conditions	From	To
Air Temperature	20°C	25°C
Air relative humidity	40%	55%
Air specific humidity	7 g/kg	10 g/kg

The refrigeration diagram, the relevant description and the operating mode diagrams of iCOM™ control describe very well how the **Liebert® HPM-S** Constant room units guarantee temperature and humidity within the requested tolerances.

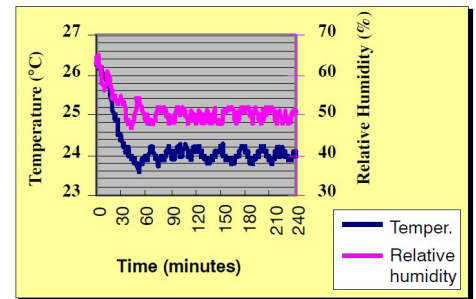

iCOM™ for Constant unit

The control of the unit for Metric Rooms is performed through the control iCOM™ Medium Board with relevant software (see T / H diagrams).

(T) Temperature control:

(Compressor + one, two or three electrical heating steps)

The compressor stops at -50% of proportional band. In the left side of the proportional band the electrical heating steps switch on to reach the set point temperature.

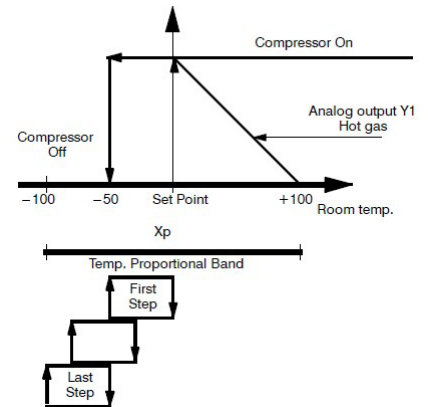

(T) Temperature control:

(Only compressor)

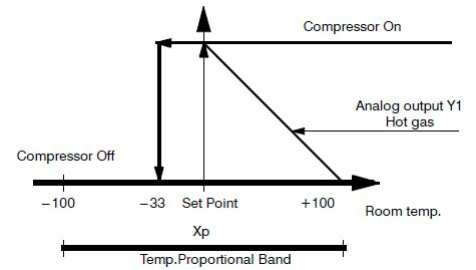

(H) Humidity control:

(Only humidification)

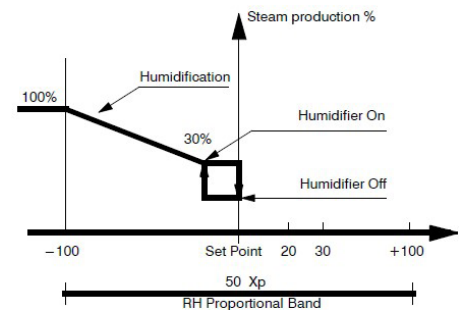

(H & D) Control mode:

(Humidification-dehumidification)

The dehumidification hysteresis can be modified from 25 to 75% of the whole humidity proportional band. If a value higher than 45% of dehumidification hysteresis is programmed the overlapping of humidification-dehumidification mode will occur.

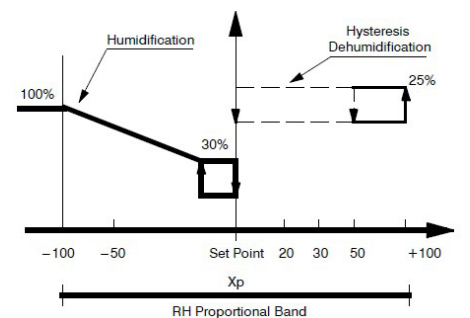

Constant K/L, Version A

Refrigeration circuit

All models are provided with a single refrigeration circuit. The compressor (1) pumps the hot gaseous refrigerant into an outdoor air-cooled condenser (2). The liquefied refrigerant arrives to a liquid receiver (3) that ensures a constant and even refrigerant flow to the thermostatic expansion valve (4) and then arrives to the evaporator (5). Here the refrigerant, thanks to the heat-exchanged with the room air moved by the fan (6) evaporates and returns to the compressor (1); from this, the refrigerant begins a new refrigeration cycle. To maintain the correct refrigerant discharge pressure, the speed of the motor fan (8) is controlled (ON-OFF or proportional mode).

When the cooling capacity of the room unit is higher than the room load and the room temperature tends to decrease, the hot gas valve (11) opens and the hot gas coil (10) heats the treated air, maintaining the room at the requested restricted temperature conditions.

Shut-off valves are provided as standard to assist with routine maintenance.

The compressor (1) has a built-in non-return valve to avoid return of liquid refrigerant from the condenser in summertime, thus protecting the compressor from undesired refrigerant slugging during the start up. A second non-return valve (7) is recommended to avoid - in wintertime - refrigerant migration from the liquid pipes and the receiver (3) to the condenser (2), that should be responsible of low pressure intervention at the start-up of compressor.

For safety reason, a relief valve (9) is installed on the liquid receiver (3); this valve is equipped with flanged connections so that the refrigerant may be discharged to the outside.

External air-cooled condenser (2)

The units may be connected with a wide range of our condensers in standard or low noise version.

For technical data and performance, refer to the relevant technical documentation *Chap 5* gives the recommended matching condenser for **Liebert® HPM-S** units as a function of outdoor air temperature.

Note 1. Units and external condensers are supplied separately.

Note 2. The room unit refrigeration circuit is pressurised with helium at 3 bar and the condenser refrigeration circuit at 2 bar with dry air.

Note 3. The customer is responsible for making connections between the Unit and the external condenser and for charging with refrigerant (standard R410A).

Full instructions for these operations are given in the Service Manual.

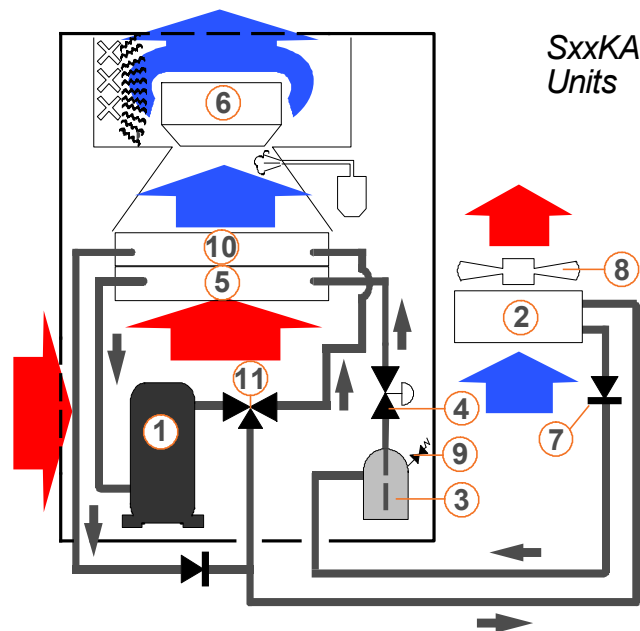

Operating Range

All Versions

Liebert® HPM-S units are designed to operate within the following working ranges (the limits concern new units on which an appropriate installation has already been made):

Room air conditions	Temperature:	
	from:	18°C, 45% R.H.
	to:	27°C, 55% R.H.
Hot water circuit	inlet water temperature	Max. 85°C
	water pressure	Max. 8.5 bar
Storage conditions	from:	-20°C
	to:	50°C
Power supply tolerances		V ± 10%, Hz ± 2

For A and D units

Outdoor temperature: lower limit		
Exceeding of winter lower limits will temporarily cause a compressor stop.		
down to +10° C	from +9° C to -20° C	below -21° C
standard unit	VARIEX required	Consult HPAC Technical Sales Support
Outdoor temperature: higher limit		
This limit is determined by coupled condenser model. Exceeding of this limit (or a lack of maintenance), will caused a compressor stop by HP safety thermostat. Reset to normal operation can only be carried out manually.		

Relative position room unit vs. remote condenser		
From unit to condenser max distance	up to 30 m equivalent length	from 30 to 50 m equivalent length
From unit to condenser max geodetic height ⁽¹⁾⁽²⁾	from 20 m to -3 m	from 30 m to -8 m
Requirements		
Pipe diameter	see Tab 12c	
Oil traps on vertical line of gas refrigerant	every 6 m, max	
Extra oil charge	see User Manual	
Variex installation	suggested	mandatory
Variex installation (on Digital circuit)	as standard	
Condenser	design	oversized +15%
Hot gas reheat	allowed	NOT allowed
Additional non return valve on delivery line, at 2 m from compressor	not necessary	mandatory

For W units

Water or mixture temperature to condenser, lower limit (other information User Manual)	min. 5°C
--	----------

Tab. 4a - Direct expansion unit SxxU/O A/W series

Model		S0F	S0H	S1A	S1D	S1E	S1G	S2E	S2G	
Power supply voltage (V ± 10%)	V/Ph/Hz	230/1/50	400V / 3Ph / 50Hz							
PERFORMANCES ⁽¹⁾										
air flow	m ³ /h	1560	2500	2680	2750	4200	4930	5200	5750	
ESP (external static pressure) (Under)	Pa	20								
ESP max (Under) ⁽²⁾	Pa	410	234	130	132	400	380	287	200	
ESP (external static pressure) (Over)	Pa	50								
ESP max. (Over) ⁽²⁾	Pa	424	233	175	133	418	379			
SPL (Sound Pressure Level) ⁽³⁾ (Under)	dB(A)	56.2	50.8	52.9	53.3	48.8	49.2	53.5	54.4	
SPL (Sound Pressure Level) ⁽³⁾ (Over)	dB(A)	57.2	53.6	56.0	56.3	51.2	52.4	53.6	55.5	
Refrigerant		R410A								
total cooling capacity	kW	5.8	7.3	11.0	13.2	16.1	18.0	24.5	25.5	
sensible cooling capacity	kW	5.3	7.3	10.1	11.3	14.7	16.8	21.0	23.0	
SHR (Sensible Heat Ratio)	-	0.91	0.96	0.92	0.86	0.91	0.93	0.86	0.90	
compressor power input	kW	1.59	2.05	2.87	3.33	3.27	3.79	5.20	5.55	
EC fan power input	kW	0.15	0.21	0.25	0.30	0.68	0.72	1.04	1.38	
total power input (compressor and fan)	kW	1.74	2.26	2.62	3.63	3.95	4.51	6.24	6.93	
EER (Energy Efficiency Ratio) (comp. + fan)	-	3.33	3.23	3.83	3.64	4.08	3.99	3.81	3.69	
Condensing section (W models only) water inlet temperature: 30°C – condensation temperature: 45°C (mid point)										
condenser type	-	plate type exchanger in AISI 316								
water flow	l/s	0.173	0.200	0.293	0.396	0.349	0.433	0.751	0.782	
water side pressure drop	kPa	5	11	21	37	16	23	53	59	
water connections (ISO 7/1)	inch	Rp ½	Rp ¾							
CHILLED WATER CONTENT										
total chilled water internal volume	dm ³	0.46	0.85				1.52			
DIMENSIONS										
length	mm	750								
depth	mm	400	500				750			
height	mm	1950								
footprint	m ²	0.30	0.38				0.56			
WEIGHTS										
net	kg	170	195	210	215	240	250	260	270	
gross	kg	175	202	217	222	250	260	270	280	

(1) **ON THE FOLLOWING STANDARD CONDITIONS:** Room conditions 24° C bs; 50% R.H. (17° C wb) - Condensing temperature: 45° C (mid point) - EER refers to the indoor unit only - Air flow of the units refers to the standard configuration with G4 class filter.

Note: Cooling capacities are gross. To obtain the net cooling capacities the fan power input must be subtracted.

(2) Max. external static pressure for the indicated air flow.

(3) Measured in the front part at 1.5 m height, 2 m distance, referred to free field, with fan and compressor in operation. Ducted Over unit.

Technical Data

Follows Tab. 4a

Model		S0F	S0H	S1A	S1D	S1E	S1G	S2E	S2G
Power supply voltage (V ± 10%)	V/Ph/Hz	230/1/50	400V / 3Ph / 50Hz						
FAN ⁽⁴⁾									
type	-	centrifugal with backward blades							
quantity	no.	1							
poles	no.	4							
OA fan	A	3.01	1.39	1.65	1.97	2.21	1.11	1.52	2.39
FLA fan	A	3.01	2.93	2.93			4.0		
LRA fan	A	0.1							
COMPRESSOR ⁽⁵⁾									
quantity / type	no.	1 / Scroll							
OA compressor (R410A)	A	7.40	3.91	4.58	5.75	10.84	5.65	6.89	10.09
FLA compressor	A	12.8	6.5	8.0	10.3	16.2	10.3	11.8	15.0
LRA compressor	A	60.0	38.0	43.0	51.5	101	51.5	64.0	101
EVAPORATING COIL									
quantity / configuration	no.	1 / inclined							
pipes / fins	-	Copper / treated aluminium							
pitch fins	mm	1.8	2.1	1.8					
rows	no.	4	3	4		5	3		4
front surface	m ²	0.28	0.48			0.65			
REFRIGERANT CONNECTIONS ⁽⁶⁾									
gas connection (pipe to be welded, o.d.)	mm	12	16			18			
liquid connection (pipe to be welded, o.d.)	mm	12				16			

(4) Fan OA is for standard unit operating at the standard pressure drop (Under 20 Pa, Over 50 Pa).

(5) Condensing temperature: 45°C (mid point).

(6) The refrigerant connections on the unit are closed with blind welded flanges.

Options (further information: Chap. 8)

Model		S0F	S0H	S1A	S1D	S1E	S1G	S2E	S2G
Power supply voltage (V ± 10%)	V/Ph/Hz	230/1/50	400V / 3Ph / 50Hz						
Electrical heating									
FLA	A	6.5				8.6			
total power / steps	kW/no.	1.50/1	4.50/3			5.85/3			
Humidifier									
FLA	A	6.5	4.6			9.0			
nominal power	kW	1.5	3.0			5.8			
Re-heating mode - Hot gas coil									
heating capacity (at 24°C, 50% R.H., condensing temperature 45°C)	kW	3.6	4.5	6.5	7.9	9.3	10.5	14	14.9
Hot water coil									
heating capacity (at 24°C, 50% R.H., water in/out 80/65°C)	kW	2.9	5.6	6.9	7.1	10.4	11.5	13	13.1
Heating mode - Hot water coil									
heating capacity (at 24°C, 50% R.H., water in/out 80/65°C)	kW	2.5	5.1	5.2	5.4	7.7	8.6	8.9	9.5

Technical Data

Tab. 4b - Direct expansion unit, S-xxD A/W series

Model		S0FD	S0HD	S1AD	S1DD	S1ED	S1GD	S2ED	S2GD
Power supply voltage (V ± 10%)	V/Ph/Hz	230/1/50	400V / 3Ph / 50Hz						
PERFORMANCE ⁽¹⁾									
airflow	m ³ /h	1160	1630	2280	2430	3790	4430	4490	5330
ESP (external static pressure)	Pa	0							
SPL (Sound Pressure Level) ⁽³⁾	dB(A)	58.1	58.5	59.4	61	58.4	59.2	59.4	61.2
Refrigerant	R410A								
total cooling capacity	kW	5.7	6.7	10.7	12.9	15.8	18.1	23.5	25.5
sensible cooling capacity	kW	4.8	5.8	9.2	10.4	13.9	15.5	19.6	22.2
SHR (Sensible Heat Ratio)	-	0.84	0.87	0.86	0.81	0.88	0.86	0.82	0.87
compressor absorbed power	kW	1.59	2.07	2.62	3.34	3.28	3.79	5.19	5.67
EC fan power input	kW	0.07	0.11	0.21	0.25	0.60	0.70	0.70	1.34
total power input (compressor and fan)	kW	1.66	2.18	2.83	3.59	3.88	4.49	5.89	7.01
EER (Energy Efficiency Ratio) (compressor and fan)	-	3.49	3.07	3.78	3.59	4.07	4.03	4.04	3.64
Condensing section (W model only) water inlet temperature: 30°C - condensation temperature: 45°C (mid point)									
condenser type	-								
water flow	l/s	0.176	0.208	0.317	0.408	0.37	0.42	0.718	0.785
water side pressure drop	kPa	5	11	24	39	17	16	43	51
water connections (ISO 7/1)	inch	Rp ½	Rp ¾						
CHILLED WATER CONTENT									
total chilled water internal volume	dm ³	0.46	0.85			1.52			
DIMENSIONS									
length	mm	750							
depth	mm	400	500			750			
height	mm	1950							
footprint	m ²	0.30	0.38			0.56			
WEIGHTS									
net	kg	170	195	210	215	240	250	260	270
gross	kg	175	202	217	222	250	260	270	280

(1) **ON THE FOLLOWING STANDARD CONDITIONS:** Room conditions 24°C bs; 50% R.H. (17°C wb) - Condensing temperature: 45°C (mid point) - **EER** refers to the indoor unit only - Air flow of the units refers to the standard configuration with G4 class filter.

Note: Cooling capacities are gross. To obtain the net cooling capacities the fan power input must be subtracted.

(2) Max. external static pressure for the indicated air flow.

(3) Measured in the front part at 1.5 m height, 2 m distance, referred to free field, with fan and compressor in operation.

Technical Data

Follows Tab. 4b

Model		S0FD	S0HD	S1AD	S1DD	S1ED	S1GD	S2ED	S2GD
Power supply voltage (V ± 10%)	V/Ph/Hz	230/1/50	400V / 3Ph / 50Hz						
FAN ⁽⁴⁾									
type	-	centrifugal with backward blades							
quantity	no.	1							
poles	no.	4							
OA fan	A	0.52	0.55	1.4	1.67	2.96	1.13	1.14	1.19
FLA fan	A	3.01	2.93			4.0			
LRA fan	A	0.1							
COMPRESSOR ⁽⁵⁾									
quantity / type	no.	1 / Scroll							
OA compressor (R410A)	A	7.36	3.92	4.57	4.57	5.66	6.89	10.09	10.55
FLA compressor	A	12.8	6.5	8.0	8.0	10.3	11.8	15	16
LRA compressor	A	60.0	38.0	43.0	51.5	51.5	64	101	95
EVAPORATING COIL									
quantity	no.	1							
pipes / fins	-	Copper / treated aluminium							
fin pitch / rows	mm/no.	1.8/4	2.1/3	1.8/4	1.8/4	1.8/3	1.8/3	1.8/4	1.8/5
front surface	m ²	0.29	0.48	0.48	0.48	0.65	0.65	0.65	0.65

(4) Fan OA is for standard unit operating at the standard pressure drop (Under 20 Pa, Over 50 Pa).

(5) Condensing temperature: 45°C (mid point).

Options (further information: Chap. 8)

Model		S0FD	S0HD	S1AD	S1DD	S1E	S1G	S2E	S2G
Power supply voltage (V ± 10%)	V/Ph/Hz	230/1/50	400V / 3Ph / 50Hz						
Electrical heating									
FLA	A	6.5				8.6			
total power / steps	kW/no.	1.50/1	4.50/3			5.85/3			
Re-heating mode - Hot gas coil									
heating capacity (at 24°C, 50% R.H., condensing temperature 45°C)	kW	3.6	4.2	6.4	7.8	9.2	10.5	13.9	15
Hot water coil									
heating capacity (at 24°C, 50% R.H., water in/out 80/65°C)	kW	2.7	4.8	6.3	6.6	9.9	10.8	11.6	12.7
Heating mode - Hot water coil									
heating capacity (at 24°C, 50% R.H., water in/out 80/65°C)	kW	2.0	3.8	4.8	5.0	7.1	8.0	8.0	9.0

Technical Data

Options (further information: Chap. 8)

Model		S1E	S2E	S2G
Power supply voltage (V ± 10%)	V/Ph/Hz	400V / 3Ph / 50Hz		
Electrical heating				
FLA	A	8.6		
total power / steps	kW/no.	5.85/3		
Humidifier				
FLA	A	9.0		
nominal power	kW	5.8		
Re-heating mode - Hot gas coil - R410A				
heating capacity (at 24°C, 50% R.H., condensing temperature 45°C)	kW	10.4	13.3	14.0
Hot water coil - DX mode - R410A				
heating capacity (at 24°C, 50% R.H., water in/out 80/65°C)	kW	12.4	13.1	13.8
Heating mode - Hot water coil				
heating capacity (at 24°C, 50% R.H., water in/out 80/65°C)	kW	9.2	9.6	10.2

Technical Data

Tab. 4c - Direct expansion unit with Frontal delivery - SxxG A/W series

Model		S0FG
Power supply voltage (V ± 10%)	V/Ph/Hz	230V / 1Ph / 50Hz
PERFORMANCE ⁽¹⁾		
airflow	m ³ /h	1350
ESP (external static pressure)	Pa	0
SPL (Sound Pressure Level) ⁽³⁾	dB(A)	61.2
Refrigerant	R410A	
total cooling capacity	kW	5.6
sensible cooling capacity	kW	4.8
SHR (Sensible Heat Ratio)	-	0.86
compressor absorbed power	kW	1.60
EC fan power input	kW	0.13
total power input (compressor and fan)	kW	1.73
EER (Energy Efficiency Ratio) (compressor and fan)	-	3.24
Condensing section (W model only) water inlet temperature: 30°C - condensation temperature: 45°C (mid point)		
condenser type	-	plate heat exchanger AISI 316
water flow	l/s	1
water side pressure drop	kPa	0.181
water connections (ISO 7/1)	inch	Rp ½
CHILLED WATER CONTENT		
total chilled water internal volume	dm ³	0.46
DIMENSIONS		
length	mm	750
depth	mm	400
height	mm	1950
footprint	m ²	0.30
WEIGHTS		
net	kg	170
gross	kg	175

(1) **ON THE FOLLOWING STANDARD CONDITIONS:** Room conditions 24°C bs; 50% R.H. (17°C wb) - Condensing temperature: 45°C (mid point) - **EER** refers to the indoor unit only - Air flow of the units refers to the standard configuration with G4 class filter.

Note: Cooling capacities are gross. To obtain the net cooling capacities the fan power input must be subtracted.

(2) Measured in the front part at 1.5 m height, 2 m distance, referred to free field, with fan and compressor in operation.

Technical Data

Follows Tab. 4c

Model		S0FG
Power supply voltage (V ± 10%)	V/Ph/Hz	230V/1Ph/50hz
FAN⁽³⁾		
type	-	centrifugal with backward blades
quantity	no.	1
poles	no.	4
speed	RpM	1512
OA fan	A	1.45
FLA fan	A	3.01
LRA fan	A	0.1
COMPRESSOR⁽⁴⁾		
quantity / type	no.	1 / Scroll
compressor rated power	Hp	1.60
OA compressor (R410A)	A	7.39
FLA compressor	A	12.8
LRA compressor	A	60.0
EVAPORATING COIL		
quantity / configuration	no.	1 / inclined
pipes / fins	-	Copper / treated aluminium
fins spacing / rows	no.	1.8/4
front surface	m ²	0.29

(3) Fan OA is for standard unit operating at the standard pressure drop (Under 20 Pa, Over 50 Pa).

(4) Condensing temperature: 45°C (mid point).

Options (further information: Chap. 8)

Model		S0FG
Power supply voltage (V ± 10%)	V/Ph/Hz	230V/1Ph/50hz
Electrical heating		
FLA	A	6.5
total power / steps	kW/no.	1.50/1
Re-heating mode - Hot gas coil		
heating capacity (at 24°C, 50% R.H., condensing temperature 45°C)	kW	3.5
Hot water coil		
heating capacity (at 24°C, 50% R.H., water in/out 80/65°C)	kW	2.9
Heating mode - Hot water coil		
heating capacity (at 24°C, 50% R.H., water in/out 80/65°C)	kW	2.3

Technical Data

Tab. 4d - Constant, S-MxxK/L A/W series

Model		S0FK/L	S0Hk	S1AK	S1DK	S1EK	S1GK	S2E	S2G
Power supply voltage (V ± 10%)	V/Ph/Hz	230/1/50	400V / 3Ph / 50Hz						
PERFORMANCE ⁽¹⁾									
airflow	m ³ /h	1310	2040	2510	2600	4070	4780	5045	5580
ESP (external static pressure) (Over)	Pa	50							
SPL (Sound Pressure Level) ⁽³⁾	dB(A)	57.6	53.9	56.4	56.9	51.7	53.0	54.1	56.1
ESP max. (Over) ⁽²⁾	Pa	601	320	213	170	400	400	287	270
ESP (external static pressure) (frontal delivery)	Pa	452	-	-	-	-	-	-	-
SPL (Sound Pressure Level) (3) (frontal delivery)	dB(A)	61.2	-	-	-	-	-	-	-
Refrigerant	R410A								
total cooling capacity	kW	5.6	7.1	10.9	13.0	16.0	18.0	23.5	25.4
sensible cooling capacity	kW	4.8	6.6	9.7	10.8	14.5	16.5	20.7	22.6
SHR (Sensible Heat Ratio)	-	0.86	0.93	0.89	0.83	0.91	0.92	0.88	0.89
compressor power input	kW	1.6	2.06	2.62	3.34	3.27	3.79	5.18	5.55
EC fan power input	kW	0.13	0.16	0.25	0.3	0.68	0.71	1.03	1.46
Condensing section (W model only) water inlet temperature: 30°C - condensation temperature: 45°C (mid point)									
condenser type	-	plate type exchanger in AISI 316							
quantity	no.	1							
water flow	l/s	0.178		0.323	0.404	0.33	0.41	0.50	0.67
water side pressure drop	kPa	5	12	25	38	8	11	16	27
water connections (ISO 7/1)	inch	Rp ½				Rp ¾			
CHILLED WATER CONTENT									
total chilled water internal volume	dm ³	0.46	0.85			1.52			
DIMENSIONS									
length	mm	750							
depth	mm	400	500			750			
height	mm	1950							
footprint	m ²	0.30	0.38			0.56			
WEIGHTS									
net	kg	170	195	210	215	240	250	260	270
gross	kg	175	202	217	222	250	260	270	280

(1) **ON THE FOLLOWING STANDARD CONDITIONS:** Room conditions 24°C bs; 50% R.H. (17°C wb) - Condensing temperature: 45°C (mid point) - **EER** refers to the indoor unit only - Air flow of the units refers to the standard configuration with G4 class filter.

Note: Cooling capacities are gross. To obtain the net cooling capacities the fan power input must be subtracted.

(2) Max. external static pressure for the indicated air flow.

(3) Measured in the front part at 1.5 m height, 2 m distance, referred to free field, with fan and compressor in operation.

Technical Data

Follows Tab. 4d

Model		S0F	S0H	S1A	S1D	S1EK	S1GK	S2E	S2G
Power supply voltage (V ± 10%)	V/Ph/Hz	230/1/50	400V / 3Ph / 50Hz						
FAN ⁽⁴⁾									
type	-	centrifugal with backward blades							
quantity	no.	1							
speed	RpM.	1050	943	1153	1241	1047	1113	999	1136
poles	no.	4							
OA fan	A	0.89	0.92	1.67	1.98	0.98	1.16	1.53	2.37
FLA fan	A	3.01	2.93			4.0			
LRA fan	A	0.10							
COMPRESSOR ⁽⁵⁾									
quantity / type	no.	1 / Scroll							
OA compressor (R410A)	A	7.39	3.91	4.57	5.75	5.65	6.90	10.08	10.84
FLA compressor	A	12.8	6.5	8.0	10.3	10.3	11.8	15.0	16.2
LRA compressor	A	60.0	38.0	43.0	51.5	51.5	64.0	101	101
EVAPORATING COIL									
quantity / configuration	no.	1 / inclined							
pipes / fins	-	Copper / treated aluminium							
fin pitch / rows	mm/no.	1.8/4	2.1/3	1.8/4	1.8/4	1.8/3	1.8/3	1.8/4	1.8/5
front surface	m ²	0.29	0.48			0.65			
Hot gas coil									
heating capacity (at 24°C, 50% R.H., condensing temperature 45°C)	kW	3.5	4.4	6.5	7.8	9.3	10.5	13.8	14.9
Humidifier									
FLA	A	6.5	5.0			13.0			
nominal power	kW	1.5	3.40			9.0			

(4) Fan OA is for standard unit operating at the standard pressure drop (Under 20 Pa, Over 50 Pa).

(5) Condensing temperature: 45°C (mid point).

Options (further information: Chap. 8)

Model		S0F	S0H	S1A	S1D	S1EK	S1GK	S2E	S2G
Power supply voltage (V ± 10%)	V/Ph/Hz	230/1/50	400V / 3Ph / 50Hz						
Electrical heating									
FLA	A	6.5				8.4			
total power / steps	kW/no.	1.50/1	4.50/3			5.85/3			

Coupling of room units with remote air-cooled condensers

The following paragraphs describe the suggested coupling of Liebert® HPM-S units. The data given below are approximate and must always be verified on the basis of the other specific operating conditions.

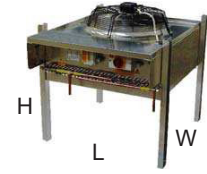

Tab. 5a - Coupling of Condensers with Liebert® HPM-A

MODELS	External temperature up to 35°C	External temperature up to 40°C	External temperature up to 46°C
S0F A	1 x HCR07	1 x HCR10	1 x HCR14
S0H A	1 x HCR10	1 x HCR14	1 x HCR24
S1A A	1 x HCR14	1 x HCR17	1 x HCR24
S1D A	1 x HCR17	1 x HCR24	1 x HCR33
S1E A/D	1 x HCR14	1 x HCR24	1 x HCR33
S1G A/D	1 x HCR14	1 x HCR24	1 x HCR33
S2E A/D	1 x HCR33	1 x HCR43	1 x HCR51
S2G A/D	1 x HCR33	1 x HCR43	1 x HCR51

Tab. 5b - Technical data and performance of Air condenser

Model		Power Supply [V/Ph/Hz]	Total Heat Rejection (THR)*	Air Volume	Noise Level **	Power Input	Current Absorption	FLA	Refrigerant Connections		Unit			
			R410A [kW]	[m3/h]	[dB(A)] @ 5 m	[kW]	[A]	[A]	Gas line [mm]	Liquid line [mm]	Dimens. [mm]	Weight [kg]		
HCR07	std.	230/1/50	6.7	2700	45.5	0.18	0.85	0.85	16	16	L=700 H=680 W=600	12.0		
HCR10	std.		10.1	2500							16.5			
HCR14	std.		13.9	4800							45.0			
HCR17	std.		17.0	4410	49.0									
HCR24	std.		24.0	8600	51.0	0.55	2.50	2.50			L=1340 H=910 W=1112	60.0		
HCR33	std.		32.2	7400							75.0			
HCR43	std.		46.0	17000	54.0	1.10	5.00	5.00			22	16	L=2340 H=910 W=1112	92.0
HCR51	std.		52.0											93.0
HBR51	std.		51.0								53.0	1.20		5.24
HCR59	std.		62.0	15600	54.0	1.10	5.00	22			7.50	22	L=3340 H=910 W=1112	136.0
HCR76	std.		78.0	25500	56.0	1.65	7.50	16	16	16				165.0
HBR76	std.		73.6											
HCR88	std.		92.0	23400	56.0	1.65	7.50	22	16	16	16	165.0		
HBR88	std.		89.0										55.0	1.80
HCR99	std.		130.0	32000	57.0	2.20	10.00	10.0	28	22	L=4338 H=910 W=1009	220.0		
HBR99	std.		118.0									2.40	10.48	22

(*) The nominal capacities refer to the following operative conditions:

- refrigerant as indicated (R410A).
- temperature differences: 15 K (T condensation – T outdoor).
- height of the installation = 0 m, above the sea level. For different altitudes, see Hirating program.
- clean exchange surfaces.

(**) The levels of sound pressure here included are measured in the same operative conditions, and are referred to 5 m far from the unit, at 1.5 m in height in free field conditions.

Heat Rejections (W version)

Coupling of water cooled units with remote Dry Coolers

The water-condensed units are provided with a water/refrigerant exchanger with braze-welded plates made of stainless steel; this advanced exchanger type gives the highest efficiency in heat exchange. In addition, a certain oversizing of the exchanger has been provided so as to reduce pressure drops (and energy consumption of the water pump) as much as possible and thus to allow the unit to operate with the external chiller in closed circuit, even at high outdoor temperatures.

The Over/Under units type W/Hare designed for operating with mains water or water in closed circuit with an external chiller. The Over/Under units type F are designed for operating with water in closed circuit with a remote Dry Cooler (or other suitable external device).

When operating in a closed circuit, the water is cooled by the outdoor air in a heat exchanger; in this case, to avoid unwanted ice formation during winter, it is advisable to use a water/glycol mixture.

The circulation of the water-glycol mixture is forced (the pump is not supplied). If mains water or tower water is used, when installing the unit fit a mechanical filter on the water line to protect the condenser against possible impurities contained in the water (for condenser cleaning see the User Manual).



Dry Coolers

Our Dry Coolers are built with a copper/aluminium cooling coil and axial fan(s). The main data on Dry Coolers is shown in the following table:

Percentage of ethylene glycol mixed with water

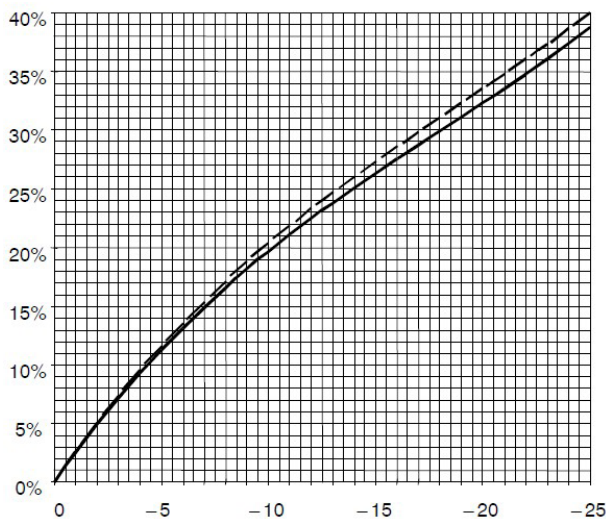

Freezing temperature °C
 - - % in weight — % in volume

Note: In the closed circuits to avoid water freezing in the cold seasons, it is strictly recommended to mix water with ethylene glycol. The suggested percentage is given in the Diagram. For safety reason, calculate the percentage at least at 5°C below the minimum ambient temperature. It is also recommended to check periodically the mixture: in case of leakage of the circuit, the sanitary water, used at compensation, reduces progressively the glycol percentage and increases the freezing point of the mixture!

Features and benefits

Liebert® HPD Dry Coolers are the new range of liquid coolers, able to cover rated heat exchange capacities from 8 to 400 kW.

They excel above all for their efficiency, versatility and reliability, thanks to the following features:

- possibility of installation with horizontal or vertical air flow with simple operations on site, with the same model of Dry Cooler, without needing any wiring or re-wiring inside the unit.
- modulating fan speed regulator with phase (optional), for a continuous modulation of the fan speed, installed on themachine, wired and factory-set, thusmaking the connection steps on site and the unit start-up extremely easy; the fan speed regulator with phase cutoff can be selected to control up to two set-point values for the water delivery temperature of the Dry Cooler. Do not use fan speed regulator other than the approved one supplied by the manufacturer. When the Dry Cooler is ordered without temperature control, an outer on/off type control (to be arranged by the customer) is anyway allowed and must be connected on site with the suitable terminals available in the electric board Q of the unit (see wiring diagram enclosed to the unit).

Heat Rejections (W version)

- The axial fans are equipped with protection grid and are statically and dynamically balanced; they can guarantee high efficiency and a low emitted noise level (above all in the low noise version); further, they are equipped with motors able to operate within a wide range of outdoor working temperatures. Protection degree IP 54. Single-phase fans feature an electric condenser incorporated in the terminal board.
- Heat exchanger with oval-geometry tubes ensuring the best air flow and thus an increase in the efficiency of the heat exchange, for a lower emitted noise level. Tubes are in copper and fins in aluminum, with wide heat exchange surface. Upon request (optional), the unit can be ordered with fins in epoxy-coated aluminum, with a better protection. The coil manifolds are in copper, with flanged connections in AISI 304 stainless steel for the models with three-phase power supply and male gas threaded connections for the single-phase models.
- the power supply is:
 - 230 V single phase 50 Hz in the ESM models (standard noise level) and ELM models (low noise level).
 - 400 V three-phase 50 Hz in the EST models (standard noise level) and ELT models (low noise level).
- Electrical boxes and accessories are water proof IP55.
- The frame is made up of a sturdy structure in galvanized steel, totally painted.
- The units are equipped with protection electric board Q, with main disconnect and safety device for fan motors.
- The most important technical data are gathered in Tab. 5d. Tests on thermal performance have been carried out at IMQ laboratories, according to the norm UNI EN 1048:2000, at the following special operating conditions:
 - Air inlet T = 35°C
 - Water inlet T = 45°C
 - Water outlet T = 40°C
 Sound pressure levels have been evaluated according to the norm EN13487, at a 10m distance, with free field.
- The working pressure depends on the circuit where the Dry Cooler is connected. Dry Coolermax working pressure = 16 bar.

All Dry Coolers are CE marking.

Dry Cooler units are conform to the following directives:

- 2006/42/EC;
- 2004/108/EC;
- 2006/95/EC;
- 97/23/EC.

Tab. 5c - Coupling of Dry Coolers

Model	External temperature up to 30°C		External temperature up to 35°C		External temperature up to 40°C	
	Standard	Low noise	Standard	Low noise	Standard	Low noise
S0F W	1 x ESM009	1 x ELM008	1 x ESM009	1 x ELM008	1 x ESM013	1 x ELM011
S0H W	1 x ESM009	1 x ELM008	1 x ESM009	1 x ELM008	1 x ESM013	1 x ELM015
S1A W	1 x ESM009	1 x ELM008	1 x ESM009	1 x ELM008	1 x ESM013	1 x ELM015
S1D W	1 x ESM009	1 x ELM011	1 x ESM013	1 x ELM011	1 x ESM018	1 x ELM018
S1E W	1 x ESM009	1 x ELM011	1 x ESM013	1 x ELM011	1 x ESM022	1 x ELM018
S1G W	1 x ESM009	1 x ELM011	1 x ESM018	1 x ELM015	1 x ESM022	1 x ELM027
S2E W	1 x ESM013	1 x ELM015	1 x ESM022	1 x ELM018	1 x EST028	1 x ELM027
S2G W	1 x ESM018	1 x ELM018	1 x EST028	1 x ELM027	1 x EST050	1 x ELT040

The table shows the recommended combinations of the Dry Coolers **Liebert® HPD** with the air conditioners **Liebert® HPD**, according to the external air temperature.

The combinations have been evaluated considering a mixture of water and ethylene glycol up to 30% as thermal exchange fluid.

The above indications are approximate and must be checked on the basis of other specific operating conditions.

For operating conditions other than those indicated in the table, refer to the New Hirting calculation software and to the Dry Coolers service manual.

6

Air Flow Characteristics

The graphs give the available and allowed external static pressure against air flow at different motor supply voltages and different signal for EC Fan for all units, with G4 air filter, standard configuration.

Useful available heads

The air conditioners of the **Liebert® HPM** series are supplied with electric fans sized for 20Pa Available External Static Pressure (ESP) for the models Under, 50 Pa for the models Over.

ESP: Available External Static Pressure.

Note: The highlighted Nominal Air flow rate is for EC Fan Full version.

Liebert® HPM - A/W versions and U/O/K configurations

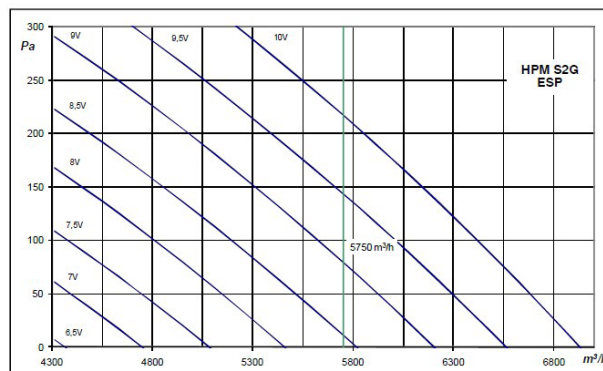
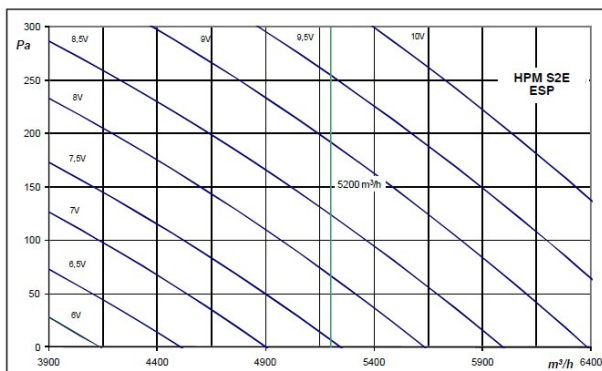
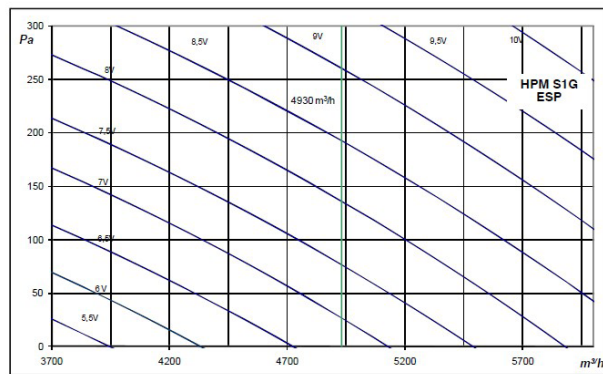
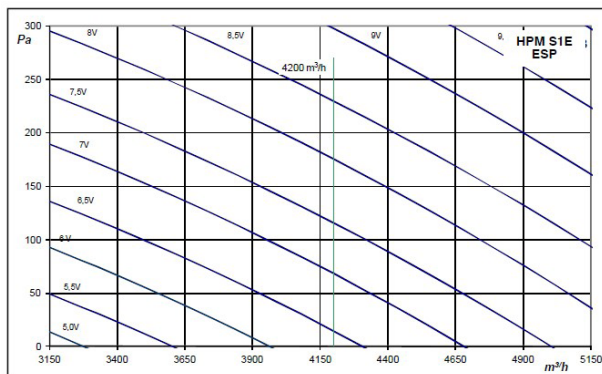
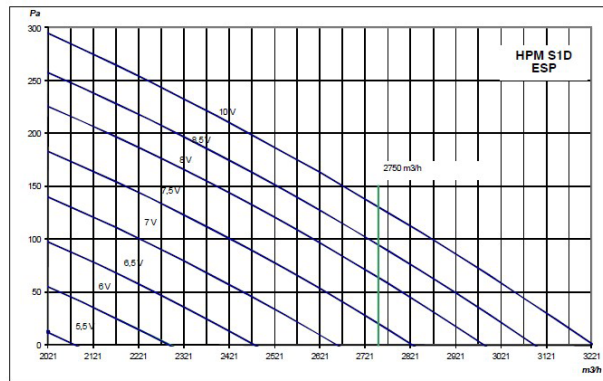
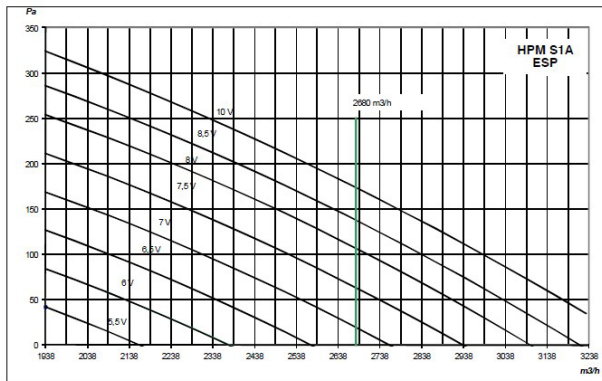
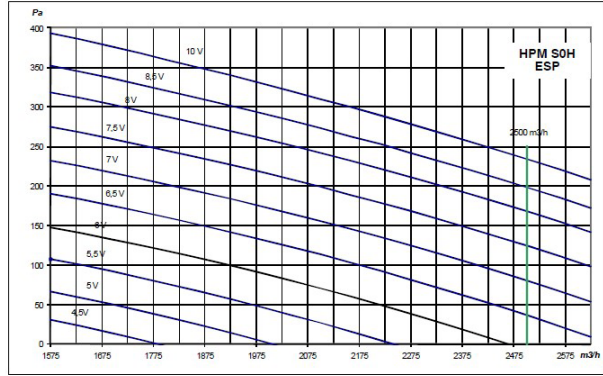
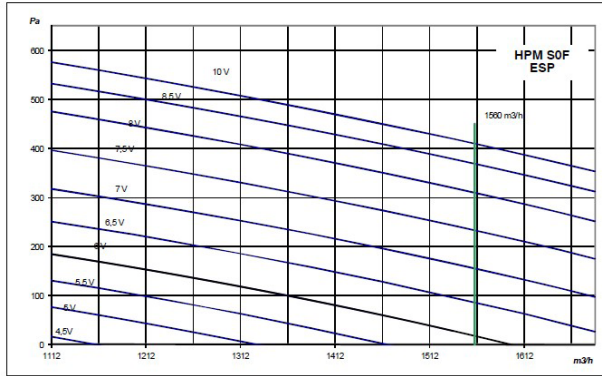

Heat Rejections (W version)

Liebert® HPM - F/D/H versions and U/O/K configurations

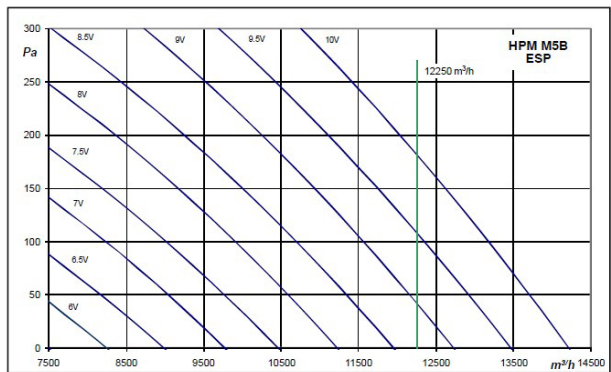
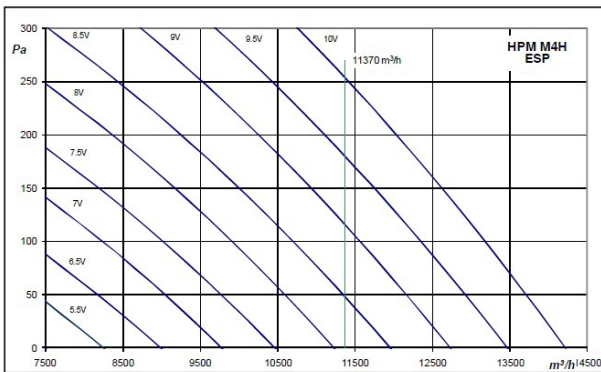
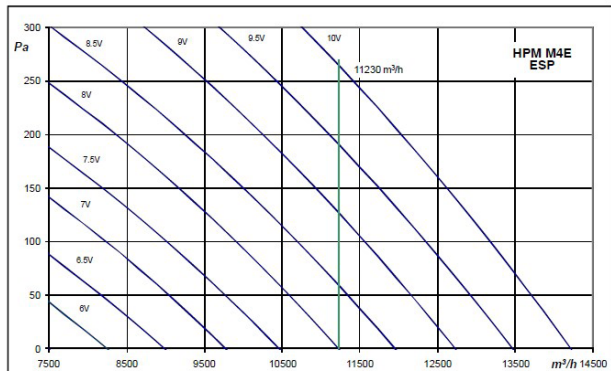
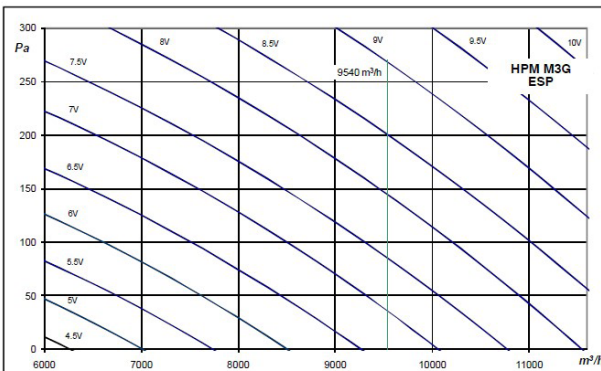
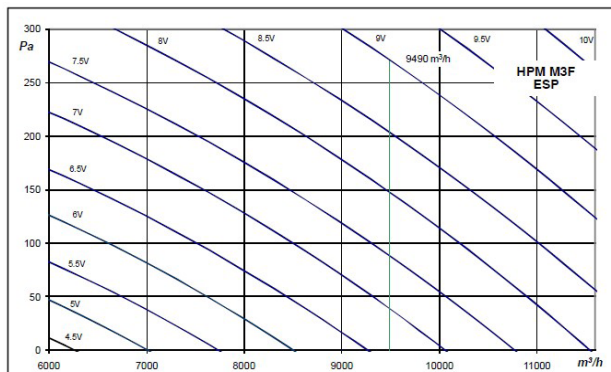
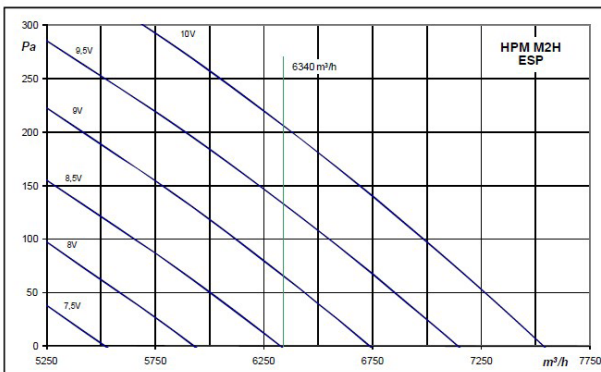
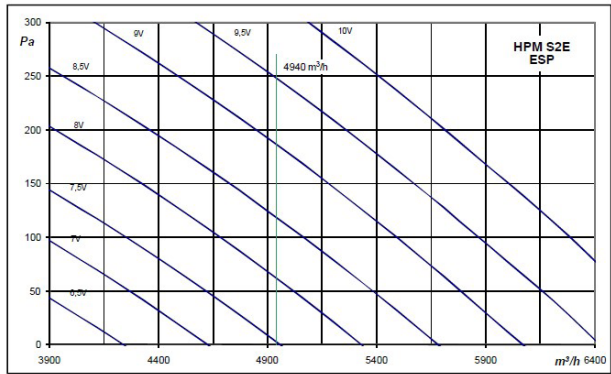
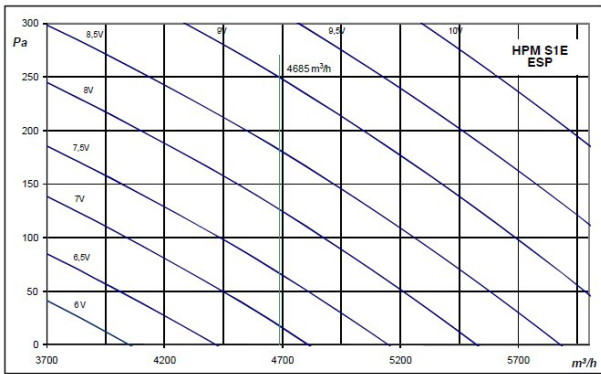

Heat Rejections (W version)

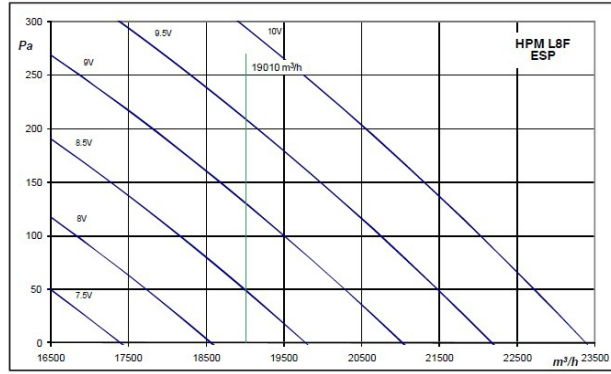
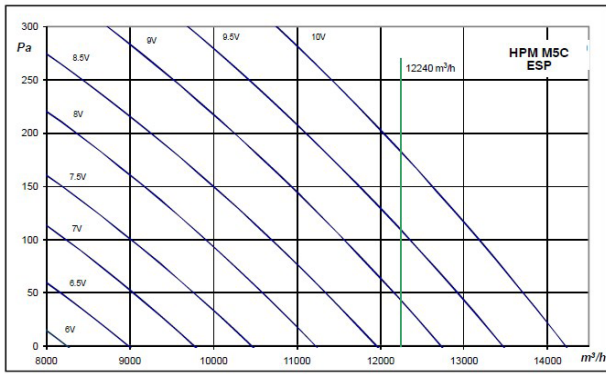

Liebert® HPM-S units have been designed with particular care for sound and vibration problems. The complete mechanical insulation of the ventilating section, combined with the special study of the aeraulic circuit as a consequence of accurate researches made in our thermodynamical laboratories and the oversizing of the components crossed by air offer the highest ventilation efficiency with the lowest sound emission.

Sound emission spectra

All tests are performed in our laboratories under the described conditions. The instrument is placed in (F) point, at 1.5 m from the ground in front of the machine at 2 m distance. Test conditions: Under unit with underflow air discharge and 20Pa available external static pressure; Over unit with ducted air discharge and 50 Pa available external static pressure. Standard air flow with clean G4 filters. Ambient temperature 24°C and relative humidity 50%. Condensing temperature 45°C. The noise levels refer to free field conditions.

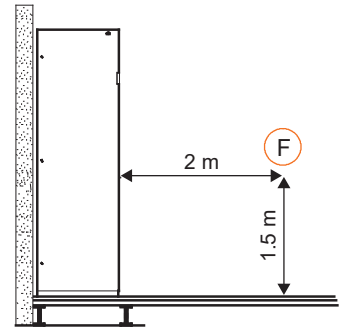

Sound emission spectra

The following tables show sound levels for every octave band frequency.

Tab. 7a - A/W versions and Under configuration

MODEL	Mode	Level	Octave band frequency (Hz)									Sound Level [dB(A)]
			31.5	63	125	250	500	1000	2000	4000	8000	
S0FUA/W	(1)	SPL	52.5	52.5	57.1	58.5	53.8	48.9	47.1	39.3	28.3	55.8
	(2)	SPL	53.2	53.2	57.4	59.3	54.1	49.3	47.2	39.4	29.0	56.2
	(3)	PWL	65.8	65.8	67.2	67.4	63.7	59.8	57.7	55.2	49.4	66.3
S0HUA/W	(1)	SPL	50.0	50.0	61.1	52.2	46.1	40.4	35.0	28.7	14.3	49.6
	(2)	SPL	50.3	50.3	61.2	52.3	48.1	42.2	39.1	36.2	26.4	50.8
	(3)	PWL	66.3	66.3	67.9	67.6	66.3	62.0	62.6	63.5	61.7	70.4
S1AUA/W	(1)	SPL	44.5	44.5	59.6	56.6	49.2	45.1	41.5	33.7	25.4	52.5
	(2)	SPL	45.0	45.0	59.7	56.7	49.8	45.5	42.2	36.1	27.4	52.9
	(3)	PWL	67.6	67.6	69.0	68.7	66.0	61.7	60.3	59.5	52.6	68.6
S1DUA/W	(1)	SPL	46.1	46.1	53.1	58.6	48.9	43.4	41.0	34.2	27.5	52.7
	(2)	SPL	46.7	46.7	53.6	58.7	49.9	44.3	42.3	37.5	29.6	53.3
	(3)	PWL	68.2	68.2	70.0	69.3	67.0	62.8	61.5	60.9	53.3	69.7
S1EUA/W	(1)	SPL	42.2	42.0	49.0	54.5	44.8	39.3	36.9	30.1	23.4	48.6
	(2)	SPL	42.7	42.7	49.6	54.6	45.4	39.4	37.0	32.3	24.7	48.8
	(3)	PWL	68.2	68.2	74.4	74.3	71.6	66.8	64.0	62.0	55.6	73.4
S1GUA/W	(1)	SPL	42.4	42.4	48.4	55.5	45.1	39.4	36.8	30.3	23.7	49.2
	(2)	SPL	43.1	43.1	49.2	55.6	45.7	39.5	36.9	32.5	25.0	49.4
	(3)	PWL	66.5	66.5	72.9	72.6	69.9	65.1	62.3	60.3	53.9	71.7
S2EUA/W	(1)	SPL	48.5	48.5	52.9	55.1	49.3	45.7	43.0	36.8	33.7	52.1
	(2)	SPL	49.4	49.4	54.3	55.4	50.4	45.8	43.1	39.3	34.5	52.7
	(3)	PWL	71.8	71.8	78.6	77.9	75.5	70.2	67.4	65.7	58.5	77
S2GUA/W	(1)	SPL	45.2	45.2	54.7	52.5	45.3	43.2	40.9	34.1	31.0	49.5
	(2)	SPL	46.1	46.1	55.2	52.7	46.6	43.3	41.0	36.3	31.6	50.0
	(3)	PWL	66.8	66.8	74.3	77.4	70.8	67.8	65.7	63.1	57.8	74.5

Sound Pressure Level

Tab. 7b - A/W versions, Over and Constant configurations

MODEL	Mode	Level	Octave band frequency (Hz)									Sound Level [dB(A)]
			31.5	63	125	250	500	1000	2000	4000	8000	
S0FOA/W S0FKA/W	(1)	SPL	56,5	56,5	60,7	56,1	55,0	50,0	46,2	39,6	29,9	56,1
	(2)	SPL	68,6	61,1	61,7	57,4	55,8	51,6	47,2	41,0	31,5	57,2
	(3)	PWL	87,0	79,5	78,7	78,7	75,0	72,8	70,4	68,3	63,1	78,5
S0HOA/W S0HKA/W	(1)	SPL	52,0	52,0	56,2	51,6	50,5	45,5	41,7	35,1	25,4	51,6
	(2)	SPL	67,1	58,7	57,9	53,9	51,9	48,2	43,5	37,5	25,5	53,6
	(3)	PWL	79,4	71,0	68,8	69,1	65,0	63,2	60,6	58,7	51,0	68,7
S1AOA/W S1AKA/W	(1)	SPL	55,5	55,5	59,7	55,1	54,0	49,0	45,2	38,6	28,9	55,1
	(2)	SPL	66,6	59,5	60,5	56,2	54,6	50,3	46,0	39,7	30,3	56,0
	(3)	PWL	79,1	72,0	71,6	71,6	67,9	65,5	63,3	61,1	55,9	71,3
S1DA/W S1DA/W	(1)	SPL	55,6	55,6	59,8	55,2	54,1	49,1	45,3	38,7	29,0	55,2
	(2)	SPL	64,5	60,0	60,7	56,5	54,9	50,6	46,2	40,0	30,6	56,3
	(3)	PWL	78,3	73,8	73,2	73,3	69,6	67,2	64,9	62,7	57,6	73,0
S1EOA/W S1EKA/W	(1)	SPL	50,2	50,2	54,4	49,8	48,7	43,7	39,9	33,3	23,6	49,8
	(2)	SPL	56,3	53,6	55,0	50,7	49,2	44,8	40,6	34,2	24,7	50,5
	(3)	PWL	76,9	72,6	76,6	77,3	73,6	71,0	67,7	63,9	59,7	76,4
S1GOA/W S1GKA/W	(1)	SPL	50,2	50,2	54,4	49,8	48,7	43,7	39,9	33,3	23,6	49,8
	(2)	SPL	56,3	53,6	55,0	50,7	49,2	44,8	40,6	34,2	24,7	50,5
	(3)	PWL	73,9	71,2	75,7	76,4	72,8	70,1	66,9	63,0	58,7	75,5
S2EOA/W S2EKA/W	(1)	SPL	55,0	55,0	59,2	54,6	53,5	48,5	44,7	38,1	28,4	54,6
	(2)	SPL	64,3	61,1	60,7	56,6	54,7	50,8	46,2	40,2	30,9	56,3
	(3)	PWL	84,9	81,7	84,4	85,3	81,3	79,1	75,5	72,0	67,9	84,3
S2GOA/W S2GKA/W	(1)	SPL	51,7	51,7	55,9	51,9	49,2	45,8	42,4	36,3	26,5	51,4
	(2)	SPL	56,5	57,4	57,2	53,5	50,5	47,6	43,5	37,7	28,2	52,9
	(3)	PWL	74,5	75,4	79,9	83,6	75,6	75,3	72,5	68,1	65,7	80,8

Tab. 7c - A/W versions and Displacement configuration

MODEL	Mode	Level	Octave band frequency (Hz)									Sound Level [dB(A)]
			31.5	63	125	250	500	1000	2000	4000	8000	
S0FDA/W	(1)	SPL	58.8	58.8	61.5	54.9	52.2	52.9	47.1	37.1	30.3	56.3
	(2)	SPL	64.7	65.5	61.9	55.1	52.9	54.4	49.7	46.3	38.0	58.1
	(3)	PWL	67.6	68.4	63.9	63.4	60.7	57.5	56.8	60.9	53.0	65.8
S0HDA/W	(1)	SPL	57.3	57.3	60.0	53.4	50.7	51.4	45.6	35.6	28.8	54.8
	(2)	SPL	67.6	67.7	61.0	53.8	52.4	54.6	50.7	48.9	40.4	58.5
	(3)	PWL	72.6	72.7	65.1	64.2	62.3	59.7	59.9	65.6	57.5	69.3
S1ADA/W	(1)	SPL	59.8	59.8	62.5	55.9	53.2	53.9	48.1	38.1	31.3	57.3
	(2)	SPL	64.7	67.3	63.0	56.1	54.1	55.7	51.2	48.2	39.8	59.4
	(3)	PWL	70.9	73.5	68.3	67.7	65.2	62.0	61.6	66.1	58.0	70.7
S1DDA/W	(1)	SPL	60.1	60.1	62.8	56.2	53.5	54.2	48.4	38.4	31.6	57.6
	(2)	SPL	63.8	70.0	63.7	56.6	55.0	57.1	53.1	51.1	42.6	61.0
	(3)	PWL	71.1	77.3	70.2	69.4	67.3	64.6	64.7	70.1	62.0	74.0
S1EDA/W	(1)	SPL	59.1	59.1	61.8	55.2	52.5	53.2	47.4	37.4	30.6	56.6
	(2)	SPL	59.3	66.0	62.2	55.4	53.2	54.7	50.1	46.9	38.5	58.4
	(3)	PWL	66.7	73.4	73.2	73.4	70.7	67.2	65.6	68.3	61.2	74.6
S1GDA/W	(1)	SPL	59.9	59.9	62.6	56.0	53.3	54.0	48.2	38.2	31.4	57.4
	(2)	SPL	59.9	66.7	63.0	56.2	54.0	55.5	50.8	47.5	39.2	59.2
	(3)	PWL	67.6	74.4	74.3	74.5	71.8	68.3	66.6	69.2	62.2	75.6

Sound Pressure Level

Tab. 7d - A/W versions, Grille and Constant top frontal flow configurations

MODEL	Mode	Level	Octave band frequency (Hz)									Sound Level [dB(A)]
			31.5	63	125	250	500	1000	2000	4000	8000	
S0FGA/W S0FLA/W	(1)	SPL	72.4	72.4	69.4	60.0	58.4	55.7	48.8	43.3	32.4	60.9
	(2)	SPL	72.4	72.6	69.5	60.5	58.7	56.1	49.3	43.8	33.2	61.2
	(3)	PWL	63.7	63.9	65.6	65.7	62.3	58.4	56.7	54.2	49.1	64.9

LEGENDA

The sound levels global and for each octave band are expressed in dB with a tolerance of (-0/+2) dB.

(1) Only ventilation (0 Pa available external static pressure), 2 m in front of the unit and 1.5 m height, in free field conditions.

(2) Working compressor (0 Pa available external static pressure), 2 m in front of the unit and 1.5 m height, in free field conditions.

(3) Working compressor, on discharge side.

Level

SPL sound pressure level

PWL sound power level

Silencing cartridges (option) - for supply (Over) and suction (Under)

These are special cartridges made of self-extinguishing material with a high noise attenuation capacity. They are guaranteed against disintegration and release of particles do to friction of the air.

It is possible to install **one** or **two** rows of cartridges in the supply hood by inserting them through the top: one single row for ≥ 600 mm height hood, two rows for a hood height 1200 mm.

Despite a small additional pressure drop, these cartridges provide a remarkable sound power level reduction (see tab. 7d).

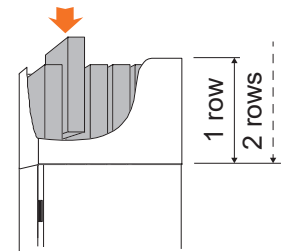

Tab. 7d - A/W versions, Grille and Constant top frontal flow configurations

MODEL	Dimensions [mm]	Free Section [mm]	Cartridge Number	
			1 row	2 rows
S0F	500 x 195 x 500	400 x 100	1	2
S0H – 1D			2	4
S1E – 2G			4	8

Tab. 7e - A/W versions, Grille and Constant top frontal flow configurations

row no.	Attenuation in dB at different frequency values (Hz)							
	63	125	250	500	1000	2000	4000	8000
1	1	4	7	15	26	28	27	14
2	1	6	12	27	49	53	49	23

Tab. 7f - Pressure drops

row no.	Attenuation in dB at different frequency values (Hz)				
	0.2	0.3	0.4	0.5	0.6
1	1	2	4	7	9
2	3	6	11	18	26

Tab. 7g - Approximate variations of Sound Pressure Level

Variations compared to values measured without noise reduction duct: free discharge (for Over units) or free suction (Under units).

Position F: 2 meters from the front, 1.5 meter from the ground.

Position D: 1 meter from the front, 45° from the top.

Unit Configuration	Plenum Height	Cartridge Rows Number	Position	
			F	D
Under	600 mm	1	-4.0 dB	-7.0 dB
	1200 mm	2	-5.0 dB	-8.0 dB
Over	600 mm	1	-7.5 dB	-12.0 dB
	1200 mm	2	-9.5 dB	-14.0 dB

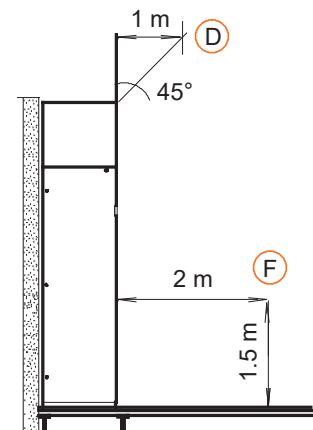

Fan (room unit)

Innovative application of single inlet centrifugal fans incorporating an impeller with curved blades corrosion resistant made of aluminium or fiberglass reinforced plastic with new design to get increased performances and sound radiation free of tonal noise.

High efficiency. The motor is three-phase (single phase on units S0Exx - S1Cxx) with IP54 protection; provided with internal thermal protection.

The fan wheel is statically and dynamically balanced; the bearings are self-lubricating.

The fan is mounted on anti-vibration rubber supports to reduce the mechanical contact with the frame and hence minimize vibration.

Available head up to 350 Pa.

Modularity.

Variable speed: several different settings; possibility to optimize air flow, available head, dehumidification operation.

Other information: see *Chap. 1*.



Air filters (see Chap. 9)

Compressor

SCROLL compressors. The scroll is a simple compression concept first patented in 1905. A scroll is an involute spiral which, when matched with a mating scroll form, generates a series of crescent-shaped gas pockets between the two members. During compression, one scroll remains stationary (fixed scroll) while the other form (orbiting scroll) is allowed to orbit (but not rotate) around the first form. As this motion occurs, the pockets between the two forms are slowly pushed to the center of the two scrolls while simultaneously being reduced in volume. When the pocket reaches the center of the scroll form, the gas, which is now at a high pressure, is discharged out of a port located at the center. During compression, several pockets are being compressed simultaneously, resulting in a very smooth process. Both the suction process (outer portion of the scroll members) and the discharge process (inner portion) are continuous.

High **COP** (Coefficient Of Performance); High **MTBF** (Mean Time Between Failure); Low sound level; Vibration-damped; Provided with internal thermal protection; Low pickup current (equalization of the internal pressures).



Coils

DX Refrigerant/room air

In such a way we can increase the global efficiency to the biggest value.

High front surface.

Made of copper pipes and aluminium fins.

Fins treated with hydrofile styrol acrylic paints to withstand corrosive atmospheres.

Low pressure drop.

High **SHR** (Sensible Heat Ratio).



Frame and panels

The sheet steel structure, painted with epoxy-polyester powders, is assembled by stainless steel rivets; the paneling system ensures higher stiffness; there will also be some pluggings (compressor space and fan) for guaranteeing both safety and high acoustic absorption.

The frontal panel is assembled on hinges to make the access easier; this can be opened by the fast closing lock.

The rear and side panels are screwed to the supports. The rear panel is screwed directly to the frame.

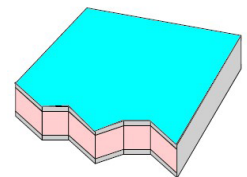

Technical Specifications

The air returns from the machine top in machines with underfloor air delivery, whereas in machines with upward air delivery it returns through the metal grid on the front panel.

The compressor section can be reached even during the unit operation by removing the front panel and the protection plugging.

The panels are lined with thermoacoustic insulating material - class 0 (ISO 11822).

Refrigerant

The units are designed for being used with refrigerant R410A.

Humidifier (option) see Chap. 11

Electrical Heaters (option) for Heating Mode

The heaters are made of:

- armored stainless steel AISI 304 for S0E---S0F models
- aluminium with high efficiency fins for all other S and L models
- finned armored stainless steel AISI 304 for **M** models:

to maintain a low surfaces power density. Ionization effects are eliminated owing to the low heater surface temperature. Each stage of electric heating is distributed across the three phases so to avoid balancing problems.

There an ON-OFF type electronic temperature controller, a safety thermostat with manual reset, a miniature circuit breaker for short-circuit protection and harness protection from possible accidental contact.

When electrical heating is installed, the dehumidification system can be also activated and humidity sensor and indicator provided, if especially ordered (see "humidification and dehumidification system" for the dehumidification function). Electric heating can be installed combined with hot gas or hot water heating.

Hot Gas Coil (option)

DX units for Reheating Mode only (versions A/W)

Liebert® HPM-S can be supplied with a reheating system that uses the heat which is normally transferred to the condenser, thus saving energy.

This system is activated during the dehumidification phase, when the temperature is below its setpoint. A control valve prevents the refrigerant from flowing into the reheat coil when not required.

Hot gas reheat is available as an alternative to hot water reheat.

Tab. 8a - Features of hot gas reheat system at nominal airflow

MODELS U/O A/W/		S0F	S0H	S1A	S1D	S1E	S1G	S2E	S2G
rows	no.	1	2		1				
surface	m ²	0.17	0.15	-		0.37			
reheating capacity (at 24°C, 50%, condensing temperature 45°C)	kW	3.6	4.5	6.5	7.9	9.3	10.5	14.0	14.9

Tab. 8b - Reheating mode during the dehumidifications

Hot gas reheat (HG) + Heaters (H1, H2) during Dehumidification mode			
	ON	OFF	Functions
first step	HG + H1	=	Reheating + Heater

Technical Specifications

Hot Water Coil

(for heating and reheating mode and dehumidification system)

The hot water heating coil is made of copper pipes and aluminium fins, with one row, test pressure 30 bar and includes an exhaust valve. A three-way ON-OFF valve directly driven by the microprocessor controller is supplied as standard.

A hot water thermostat (provided by the customer) is installed to indicate the presence of hot water at the correct temperature. When hot water heating is installed, the dehumidification system can also activated and a humidity sensor and indicator provided, if especially ordered (see "humidification and dehumidification system" for the dehumidification function).

The hot water heating/reheat system can be installed as an alternative to the hot gas reheat system.

Tab. 8c - Features of hot water reheat system at nominal airflow

MODELS U/O A/W/		S0F	S0H	S1A	S1D	S1E	S1G	S2E	S2G
rows	no.	1	2			1			
surface	m ²	0.17	-			0.37			
indoor temp. 24°C, 50% R.H.; water inlet/outlet temperature 80/65°C; condensing temperature 45°C									
power (re-heating)	kW	2.9	5.6	6.9	7.1	10.3	11.4	12.1	13.2
water flow	l/s	0.047	0.092	0.112	0.116	0.170	0.190	0.200	0.220
coil side pressure drops	kPa	1							
total pressure drops	kPa	1			4	5		3	
indoor temp. 24°C, 50% R.H.; water inlet/outlet temperature 80/65°C; condensing temperature 45°C									
power (re-heating)	kW	3.1	6.0	7.3	7.6	11.1	12.3	13.1	14.2
water flow	l/s	0.051	0.098	0.119	0.123	0.180	0.200	0.210	0.290
coil side pressure drops	kPa	1							
total pressure drops	kPa	1		2	4	5	6	3	

Tab. 8d - Reheating mode during the dehumidifications

Hot gas reheat (HG) + Heaters (H1, H2) during Dehumidification mode			
	ON	OFF	Functions
first step	HW + H1	=	Reheating + Heater

Tab. 8e - Features of hot water heating system at nominal airflow

MODELS U/O A/W/		S0F	S0H	S1A	S1D	S1E	S1G	S2E	S2G
rows	no.	-	-	-	-	1			
surface	m ²	-	-	-	-	0.37			
indoor temp. 24°C, 50% R.H.; water inlet/outlet temperature 80/65°C; condensing temperature 45°C									
power (re-heating)	kW	2.5	5.1	5.2	5.4	7.7	8.6	8.9	9.5
water flow	l/s	0.040	0.083	0.090	0.089	0.130	0.140	0.150	
coil side pressure drops	kPa	1							
total pressure drops	kPa	2			3	4		2	
indoor temp. 24°C, 50% R.H.; water inlet/outlet temperature 80/65°C; condensing temperature 45°C									
power (re-heating)	kW	2.7	5.6	5.8	6.0	8.8	9.7	10.1	10.7
water flow	l/s	0.045	0.092	0.096	0.097	0.140	0.160	0.160	0.180
coil side pressure drops	kPa	1							
total pressure drops	kPa	2		1	3	4		2	

Technical Specifications

Water-cooled Condenser - DX - W/F/H units (see Chap. 5)

Electric board

The electric board is housed in the front part in a space insulated against the air flow and protected by a cover, so as to avoid tampering by non-authorized personnel and to protect the electric board parts supplied with a voltage higher than 24 V.



The electric board complies with the norm 204-1 IEC.

The air conditioners have been provided for operating at 400 V-/3/50 Hz+N+G (as special alternative execution, the version with 220-V/3/50Hz + G can be supplied) and at 380 V-/3/60 Hz+N+G and 230V-/3/60 Hz+G.

Magnetothermal switches are supplied as protection of every electric component. A single-phase transformer has been provided for supplying power to the secondary circuit at 24 V.

A main switch with door-locking handle is installed to prevent it from being removed when the switch is in the operating position.

There will be an automatic start-up after a possible stop due to power supply lack.

Additional terminals for remote start-up and carry of some operating conditions (fans and compressors) or connection of additional devices (Liquistat, Firestat, Smokestat, clogged filters) are available on the terminal block of the electric board. On the terminal block there is also a clean contact for the remote signalling of the general alarm.

Outdoor Components

Air-cooled Condenser

DX - A/D units (see Product Documentation of HCE condenser).

For pipe layout and unit connection, see *Chap. 12* and USER MANUAL in the unit (or surfed on the web).



Dry-Cooler

DX - W/F/H units



Standard filters

Removable filters installed inside the unit before of fan and heat exchanger.

Filtration from G4 to F5 (CN EN779 - respectively corresponding to EU4 and EU5 according to Eurovent EU4/5).

The folded structure of the filters gives high filtration efficiency and low pressure drop.

The filter media used consists of synthetic fibre cells. The frame is made of cardboard.

The additional pressure drop in comparison with G4 sdt filters are indicated in *Tab. 9c*.



High efficiency filters

Optional high efficiency filters, filtration class F6, F7 and F9 in accordance with the CEN EN 779 standard, are made of fibreglass filter media. The filters are placed in "V" sections with a solid external frame in polypropylene, and can withstand remarkable pressure and flow variations. These filters will be installed within an additional duct on the unit top.

Filter holding duct

If 290 mm high filters are needed, a metal hood must be supplied to support them, installed on the top of the unit and with the same colour. For dimensions see *Fig. 12.d*.

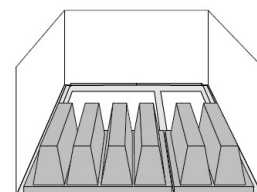

Clogged filter alarm

A differential static pressure gauge after and before the filter gives a signal when the filter is dirty.

Fresh air kit

The fresh air kit, optional, has a G3 class filter installed on the intake side of the fan and is connected to the **Liebert® HPM-S** unit with a 100 mm diameter plastic duct.

As the fresh air intake is positioned close to the fan suction, it will easily mix with the recirculation air.

Air Filters general information

Recently new test methods and configuration systems have been developed for all type of filters. In Europe, CEN is working to establish common standards, in the United States ASHRAE Standards has been in use since 1968, and replaced by ANSI/ASHRAE 52.1-1992. So, in order to have a reference about different standards, see *Tab. 9a* and *Tab 9b*. There is no perfect correspondence between different standards, due to the different test methods, but the tables can be used as general guide.

Tab. 9a - Comparison between air filter tests

Eurovent 4/9	EN 779 EN 1882	Average Arrestance * [ASHRAE Standard 52.1-1992]		Average Dust Spot Efficiency ** [ASHRAE Standard 52.1-1992]		Minimum Efficiency Reporting Value [ASHRAE 52.2-1999]
		[greater then or equal to]	[less than]	[greater then or equal to]	[less than]	
EU1	G1	60%	65%		20%	1-4
EU2	G2	65%	80%	20%		4
EU3	G3	80%	90%	20%		5
EU4	G4	90%	95%	20%	30%	6-7-8
EU5	F5	95%	98%	40%	60%	8-9-10
EU6	F6	99%		60%	80%	10-11-12-13
EU7	F7	99%		80%	90%	13-14
EU8	F8	99%		90%	95%	14-15
EU9	F9	99%		95%		15

* Achieved filtering performance in accordance to gravimetric test method on a specific sample of dust;

** Achieved filtering performance in accordance to a light transmission test methods, with natural atmospheric dust.

Filter section

Tab. 9b - Approximate efficiency versus particle size for typical air filters

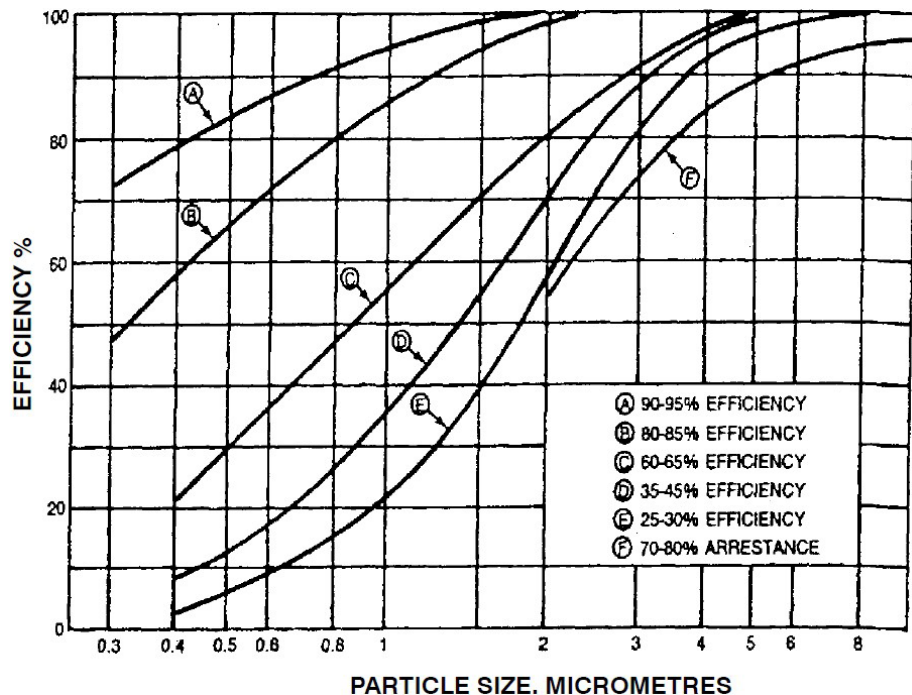

Curves are approximation for general guidance only. Efficiency and arrestance per ASHRAE Std 52.1 test method [From ASHRAE Handbook, HVAC Systems and Equipment].

Tab. 9c - Additional pressure drop Filters F5

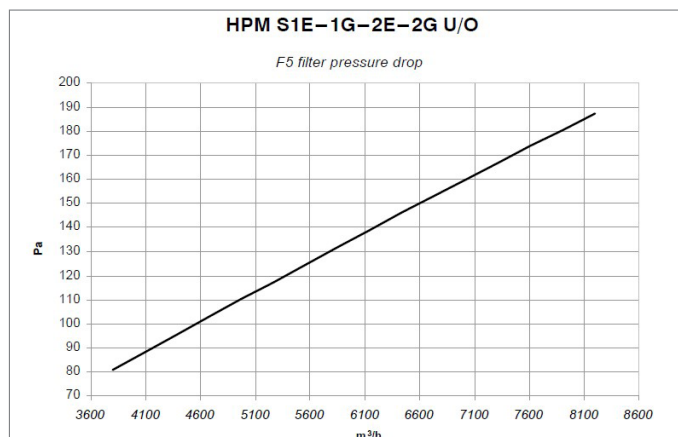
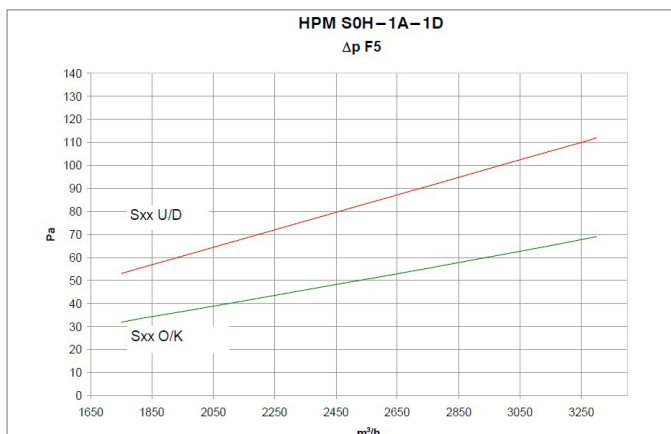
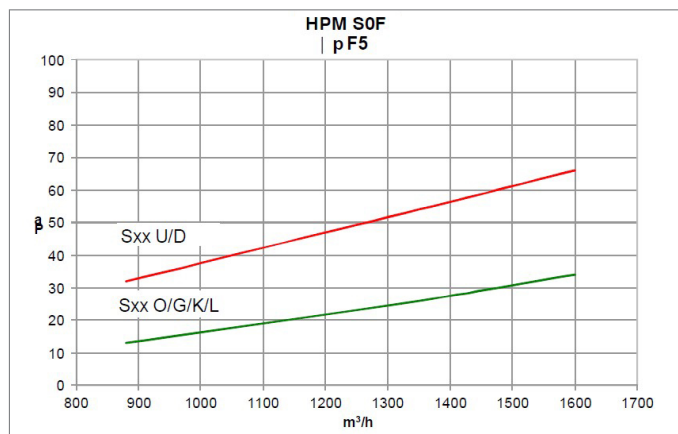

Filter section

Tab. 9d - Additional pressure drop Filters F6

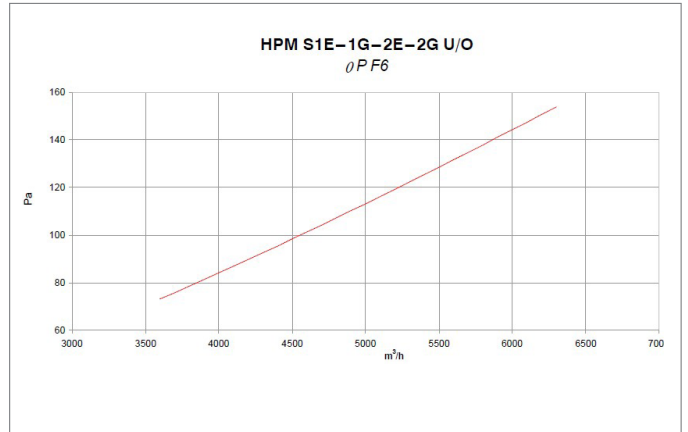
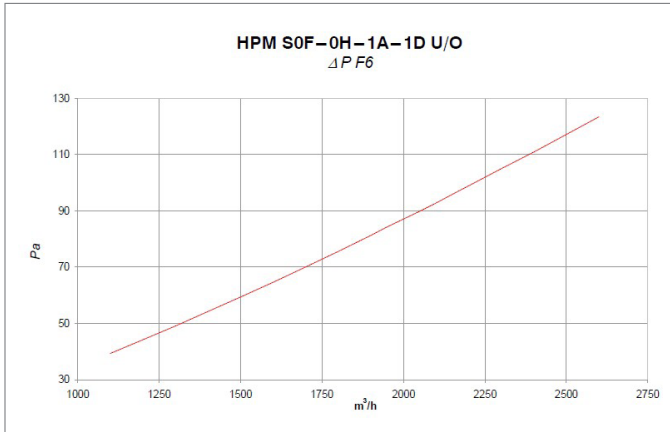

Tab. 9e - Additional pressure drop Filters F7

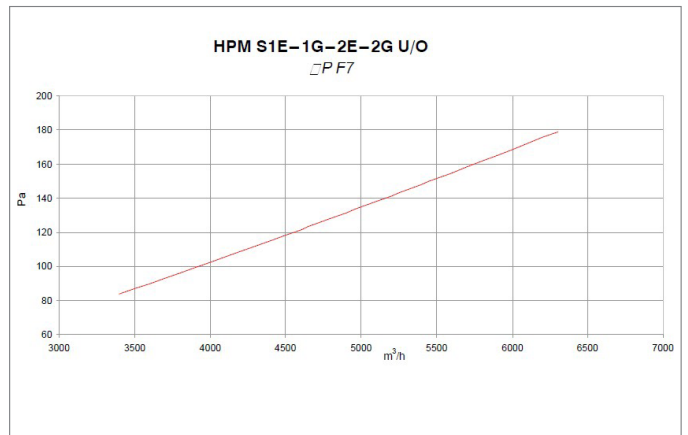
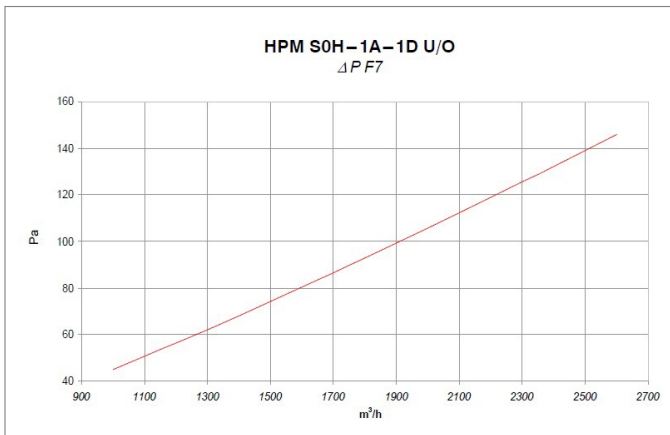

Tab. 9f - Additional pressure drop Filters F9

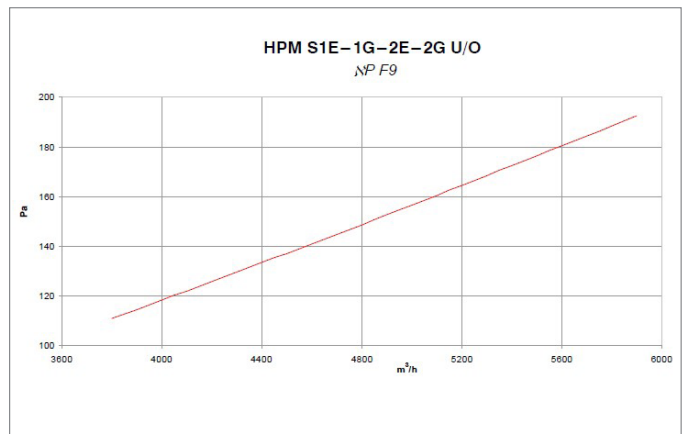
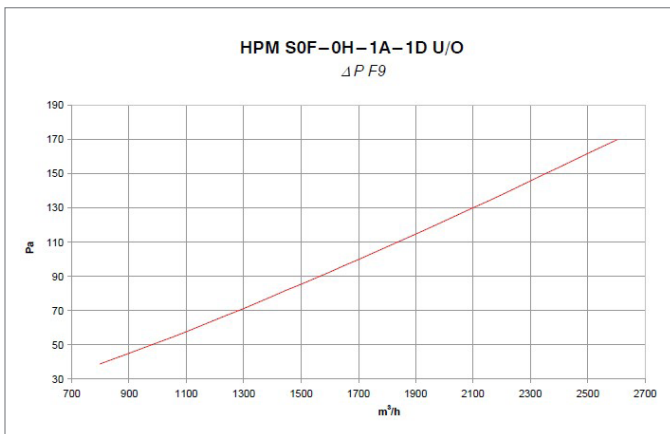

Filter section

Control System

Control system and display

ON/OFF switch and indication	<p>An ON/OFF switch (placed in the internal electrical panel) allows to turn ON-OFF the unit in case the display is not available.</p> <p>A LED provides visual indication of the unit ON/OFF status.</p>
Microprocessor features	<p>The unit control system is microprocessor based.</p> <p>Terminals are provided for remote start/stop control plus Volt-free 'Common Alarm', 'Common Warning'.</p> <p>Microprocessor features for single circuit units:</p> <ul style="list-style-type: none"> - up to 6 configurable digital inputs (for instance condensate pump alarm, heater alarm, fire alarm, water alarm, no power, etc..) - 1 digital input for remote ON/OFF - 2 digital outputs to report general warning and general alarm - 1 Ethernet port <p>Microprocessor features for double circuit units:</p> <ul style="list-style-type: none"> - Up to 8 configurable digital inputs (for instance condensate pump alarm, heater alarm, fire alarm, water alarm, no power, etc..) - 1 digital input for remote ON/OFF - 2 digital outputs to report general warning and general alarm - 1 Ethernet port
Programming devices	<p>The microprocessor can be programmed by one of the following devices:</p> <ul style="list-style-type: none"> - 7 inch, high definition (resolution 800 x 480 pixel), color resistive touchscreen display. Power supply = 24 V_{DC}. - 10 inch, high definition (resolution 1280 x 800 pixel), widescreen, multitouch projected capacitive touchscreen display. Power supply = 24V_{DC}. - Small semi-graphic LCD display - External PC/Laptop <p>NOTE All the display functions can also be replicated in a web browser.</p>
Menu-driven control	<p>The system displays user menus for active alarms, event log, graphic data, unit view/status overview (including the monitoring of room conditions, operational status in percentage of each function, date and time), various sensors and display setup.</p> <p>A password is required to make system changes.</p> <p>Service menus include setpoints, standby settings, total run hours, timers/sleep mode, alarm setup, sensor calibration, options setup, system/network setup, auxiliary boards and service control mode.</p>
Main control functions	<p>The unit control provides the following functions:</p> <ul style="list-style-type: none"> - unit to unit Ethernet connection to operate with multiple units - run/stand-by rotation - automatic changeover and parameter sharing functions - external communications through BMS or service remote monitoring solution - sequential auto restart timer, with adjustable time delays to be applied to unit restart after a power loss
Warnings / alarms	<p>More than 240 types of warnings / alarms / messages are displayed including:</p> <ul style="list-style-type: none"> - high temperature - low temperature - high relative humidity - low relative humidity - compressor failure - fan failure - electrical heater high temperature - sensor failure

Microprocessor Controls

Sensors	<p>Each unit has one factory mounted supply temperature sensor and one return temperature and humidity sensor.</p> <p>The control as standard allows to manage:</p> <ul style="list-style-type: none"> - a return temperature and humidity sensor - a supply temperature sensor - up to 10 remote temperature and humidity sensors - up to 3 room temperature and humidity reference sensors <p>When multiple remote sensors are installed, the user can choose the minimum, maximum or average value.</p> <p>This value will be used by the control for managing the unit.</p> <p>The user can also choose the redundancy option, in this case the control will consider the value of the first sensor only; the second sensor will be used only if the first one is broken or missing. The same rule will be applied for succeeding redundant sensors.</p> <p>The cooling capacity and fan speed can be controlled from multiple different sensor selections.</p> <p>In case of sensor failure, the unit automatically adapts and switch to a different preset emergency control mode.</p>
PID settings	<p>The control has auto adaptive algorithms known as PIDs.</p> <p>The user can adjust the set points of the main PIDs (like air temperature and humidity control). Specific PIDs settings can be adjusted by the Service Personnel during commissioning.</p> <p>Cooling capacity and fan speed PIDs can be decoupled, if needed.</p>
Temperature control mode	<p>The temperature control mode defines from which sensor the cooling capacity will be driven.</p> <p>The following options are available:</p> <ul style="list-style-type: none"> - return - supply - remote
Fan speed control mode	<p>The fan speed control mode defines how airflow will be controlled.</p> <p>The following options are available:</p> <ul style="list-style-type: none"> - return sensor - remote sensor - delta t between return temperature and supply temperature - static pressure - fixed speed
Humidity control mode	<p>The humidity control mode defines from which sensor humidification and dehumidification will be driven.</p> <p>The following options are available:</p> <ul style="list-style-type: none"> - return - remote
Humidity Control Type	<p>The following options are available:</p> <ul style="list-style-type: none"> - relative - relative compensated - absolute - dew point

Humidification

The humidification system is provided by a **HUMIDAIR** electronic humidifier. The dehumidification function, which is supplied as standard when the humidifier option is installed, acts by reducing the fan speed with consequent reduction of the air flow and at the same time switching on the compressor.

Electronic humidity control

The software of the iCOM™ microprocessor control includes an algorithm which manages the **HUMIDAIR** electronic modulating humidifier and also provides the dehumidification function. There is also a special function which automatically prevents dehumidification if the return air temperature is below the required value. When the temperature reaches the correct value, the dehumidification function is automatically reactivated. Dehumidification control may be either of the proportional or of the ON-OFF type, depending on the installation requirements: ON-OFF is set as standard at the factory.

HUMIDAIR electric steam humidifier

HUMIDAIR is a replaceable plastic water cylinder with immersed electrodes. When an electronic current passes between the electrodes, the water is converted into the required quantity of steam. It is suitable for a large range of water qualities (with varying degrees of hardness) with the exception of demineralized water. It almost instantaneously produces clean, particle-free steam and avoids energy losses which are typical of other systems.

HUMIDAIR is provided with the steam cylinder, water inlet and outlet valves and a maximum level sensor. The steam output can be adjusted within a range of values which can be chosen manually and is factory-set at 70% of the maximum capacity (see the relevant data).

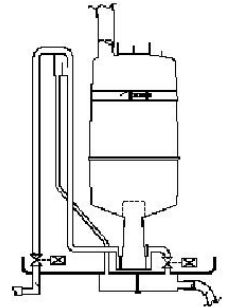

Humidifier features

The steam is mixed with the delivery air of the evaporating coil by means of a suitable distributor. The iCOM™ controller can determine when the cylinder has to be changed. Replacing the cylinder is extremely easy and quick. A self-adaptive flow control system is fitted as standard and controls the current passing through the cylinder water.

Tab. 11a - HUMIDAIR specifications

HPM MODEL	HUMIDAIR MODEL	MAIN POWER SUPPLIES (V ± 10%)	SETTING	ABSORBED CURRENT	POWER	MAX. CYLINDER WATER VOLUME	MAX. SUPPLY WATER QUANTITY	MAX. DRAIN WATER QUANTITY
			[kg/h] *	[A]	[kW]	[l]	[l/min.]	[l/min.]
S0F	KUECLA	230V / 1ph / 50Hz	0.6 ... 1.5	6,5	1,5	1.7	0.6	4.0
S0H-1A-1D	KUECLB	400V / 3ph / 50Hz	1.3 ... 3.0	3,2	2,25	3.3	0.6	4.0
S1E-1G-2E-2G	KUECLD		3.9 ... 8.0	8,7	6	5.5	0.6	4.0

Tab. 11b - HUMIDAIR specifications for Displacement unit

HPM MODEL	HUMIDAIR MODEL	MAIN POWER SUPPLIES (V ± 10%)	SETTING	ABSORBED CURRENT	POWER	MAX. CYLINDER WATER VOLUME	MAX. SUPPLY WATER QUANTITY	MAX. DRAIN WATER QUANTITY
			[kg/h] *	[A]	[kW]	[l]	[l/min.]	[l/min.]
S0F D	KUECLA	230V / 1ph / 50Hz	0.6 ... 1.5	6,5	1,5	1.7	0.6	4.0
S0H-1A-1D D	KUECLB	400V / 3ph / 50Hz	1.3 ... 3.0	3,2	2,25	3.3	0.6	4.0
S1E-1G-2E-2G	KUECLD		3.9 ... 4.5	4,6	3	5.5	0.6	4.0

For humidifier current (FLA) and rated power refer to electrical features in air conditioner manual.

(*) Unit is factory-set to produce about 70% of the maximum value (see iCOM™ manual).

12

Dimensional Data/Connections

Fig. 12.1 - Overall dimensions Service Area - S models

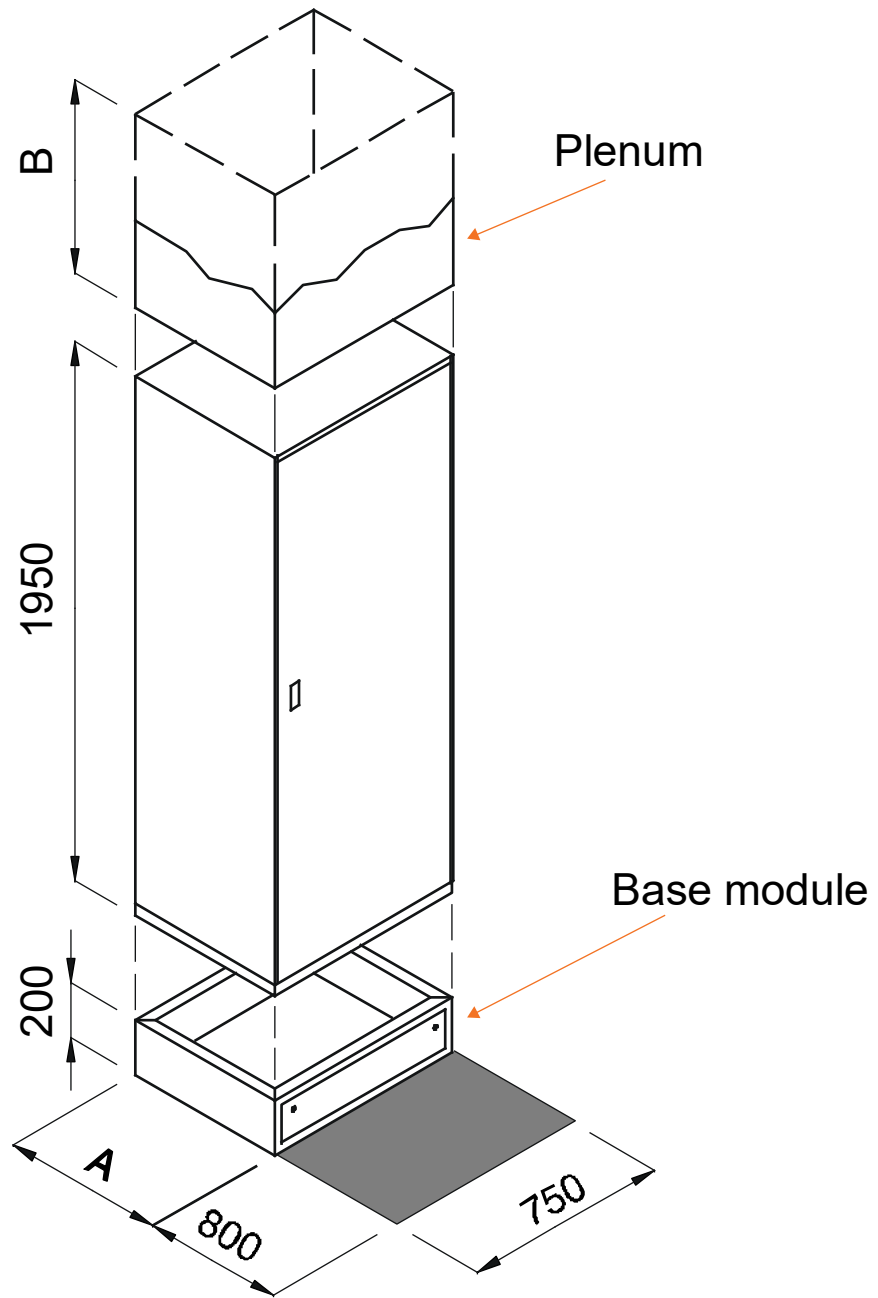

Models	A (mm)	AVAILABLE PLENUM HEIGHTS: B (mm)			
		Simple Plenum	Plenum for silencing cartridges	Plenum for high efficiency filters	Plenum with frontal airflow (OVER only)
S0F	400	500-600-700-800 900-1000-1100-1200	600-900-1200	500-600-700 800-900	600
S0H-1A-1D	500				
S1E-1G-2E-2G	750				

Dimensional Data/Connections

Models	WEIGHTS (kg)						
	Versions						
	A	W	F	D	H	K/A	K/W
S0F	160	165				170	174
S0H	170	175				200	205
S1A	210	215				215	220
S1D	215	222				222	229
S1E	240	247				247	254
S1G	250	260	290	280	290	260	270
S2E	260	270	310	300	310	270	280
S2G	270	280	320	310	320	280	290

Power supply requirements for the unit

- Check the electrical data on the label applied on the unit.
- Check that the available power supply is consistent with the unit power requirements.
- Refer to the electrical schematic supplied with the unit when making line voltage supply, low voltage main unit interlock and any low voltage alarm connections.

Local codes

- Electrical service must conform to national and local electrical codes.
- All wiring must be done in accordance with all applicable local, state, and national electrical codes.

External disconnecting switch

- The final customer must install on site an external disconnecting switch, easy to reach, to facilitate a quick and easy shutdown and power cut off of the unit.
- According to EN60204-1 standard, paragraph 5.3, an ON/OFF handle must be easily accessible and positioned between 0.6m and 1.9m above the service level. When this is not available on the front door of the unit, it is mandatory to install an external disconnecting device (for all power sources to the unit) positioned as close as possible to the unit, easy accessible, visible and located between 0.6m and 1.9m above the service level.

Fig. 12.2 - Air inlet and outlet - hole for plenum connection

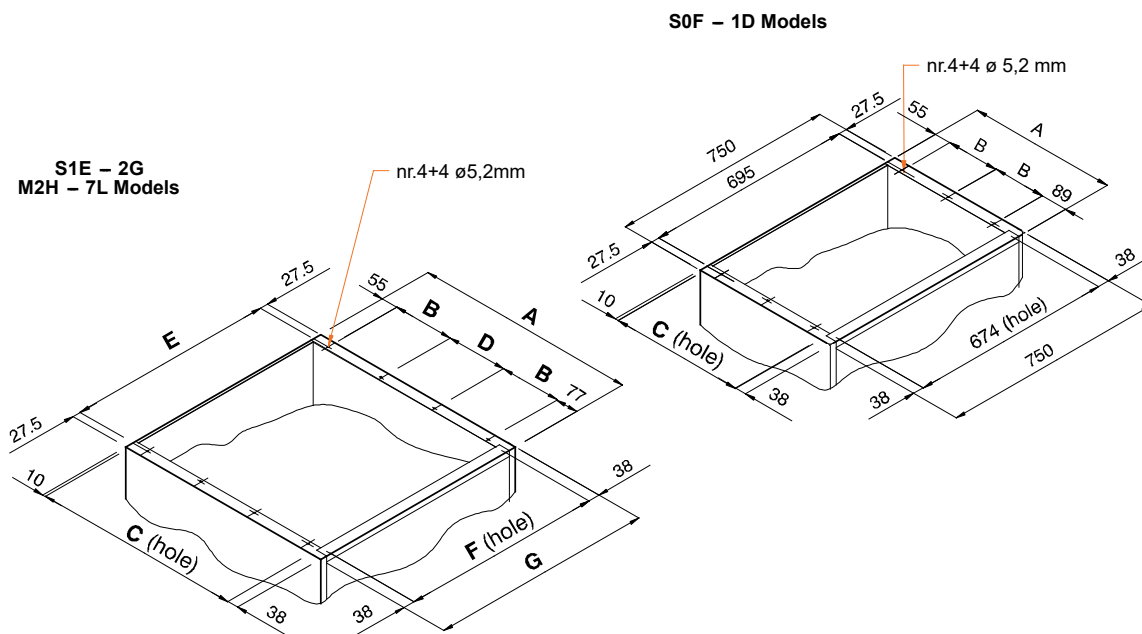

Models	A mm	B mm	C mm	D mm	E mm	F mm	G mm
S0F	400	128	352				
S0H-1A-1D	500	178	452				
S1E-1G-2E-2G	750	206	702	206	695	674	750

Dimensional Data/Connections

Fig. 12.3 - Hole in raised floor

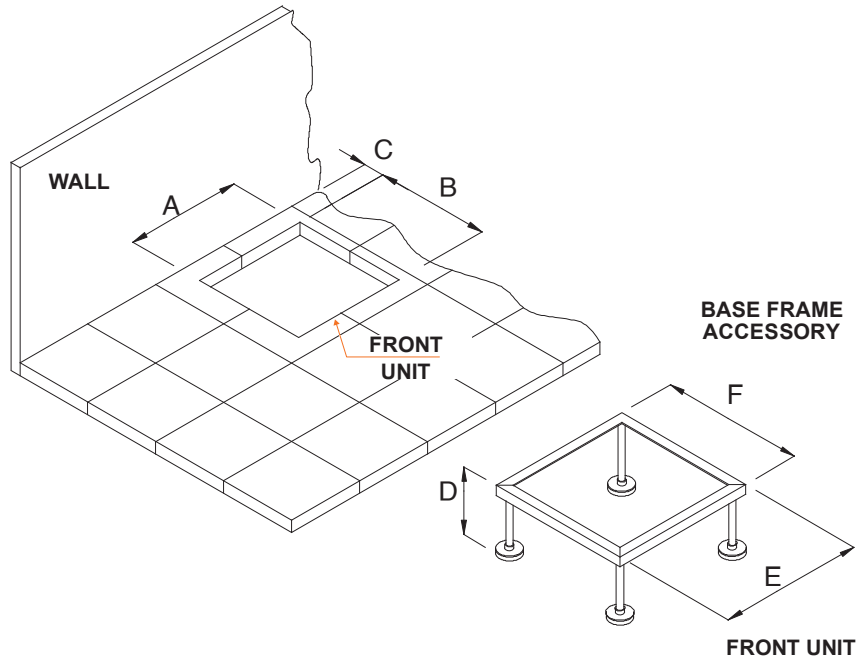

Models	Dimensions (mm)								
	A		B		C		D	E	F
	without base frame	with base frame	without base frame	with base frame	without base frame	with base frame			
S0F			320	390			± 300		380
S0H-1A-1D	690	750	420	490	50	10	± 500	740	480
S1E-1G-2E-2G			670	740			± 800		730



CAUTION: For "UNDER" units installed on raised floor, inhibit inappropriate access to the unit from the base to not-authorized staff: i.e. fixing the floor panels up to 850 mm from the unit.

Fig. 12.4 - Extension hood

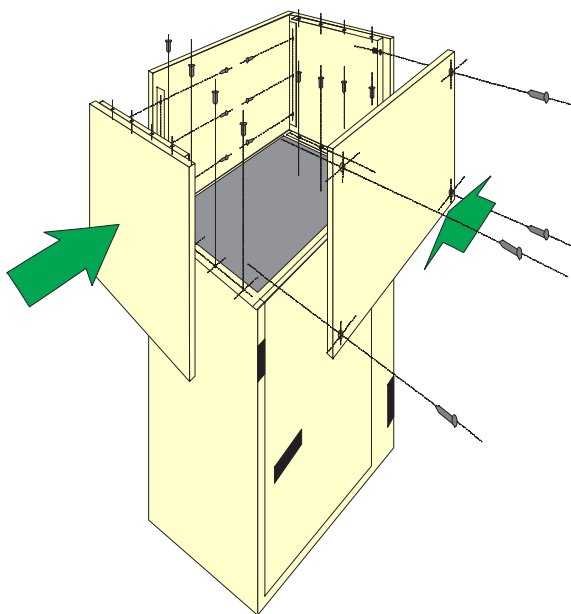
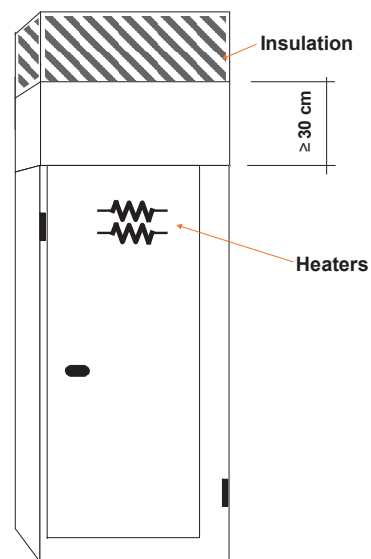
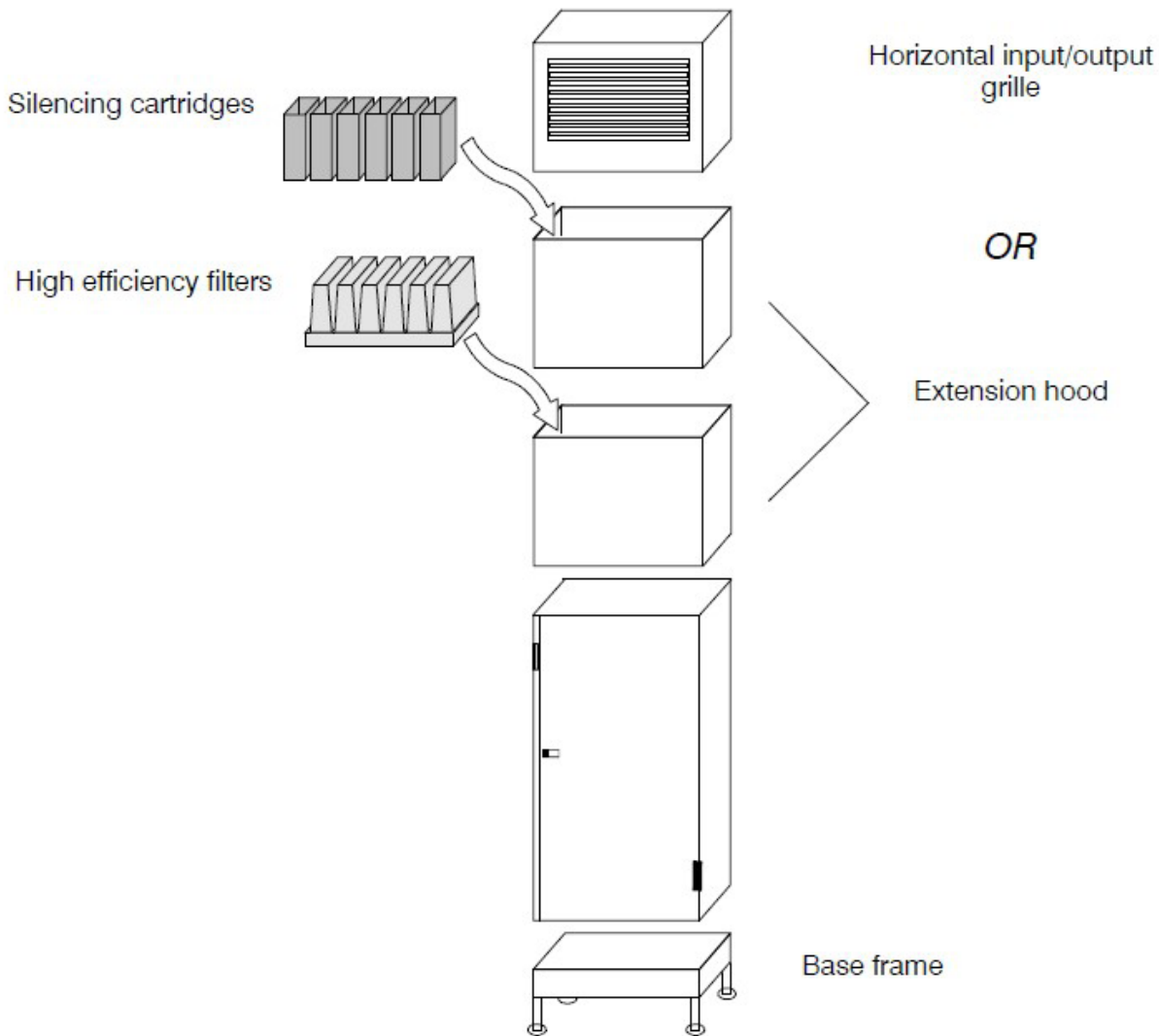

Fig. 12.5 - Over conditioner with electrical heaters. Upflow ducted conditioner equipped with electrical heaters, connected to air duct not supplied by Vertiv™. Pay attention to the position of insulating material!



Dimensional Data/Connections

Fig. 12.6 - Overall dimensions Service Area - S models



Plenum with frontal airflow (Over)

A supply plenum with horizontal air flow can be installed on top of the unit. The 600 mm high plenum has the same design as the unit; it consists of sandwich panels lined with non-flammable insulation material of class 0 (ISO 1182.2), density 30 kg/m³ (see Fig. 12b). It is equipped with a double deflection grille. A single deflection double fin grille can be supplied.

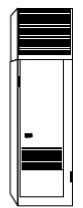

Fig. 12.7

Base modules (Over)

A 200 mm high base module can be supplied on request to support Liebert® HPM-S Over units and at the same time allow pipework to enter the base of the unit when a raised floor is not installed. Some 300 or 500 mm base modules with air filter G4 or F5 efficiency, can be supplied on request to support Liebert® HPM-S Over units with bottom or rear air intake. Note that in this case the air conditioning unit must be ordered with a blind front panel.

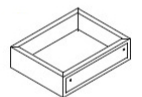

Fig. 12.8

Intake and delivery hoods

Liebert® HPM-S can be equipped with intake and supply ducts on the top for connection of the unit to a false ceiling. The air duct is manufactured to complement the design of the unit; it consists of sandwich panels lined with non-flammable insulation material of Class 0 (ISO 1182.2), density 30 kg/m³; its height ranges between 500 mm and 1200 mm (see Fig. 12a).



Fig. 12.9

Dimensional Data/Connections

Fig. C 6 – Base module

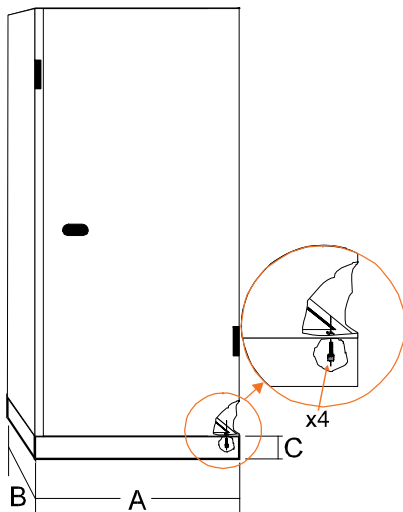

Fig. C 7 – Base frame

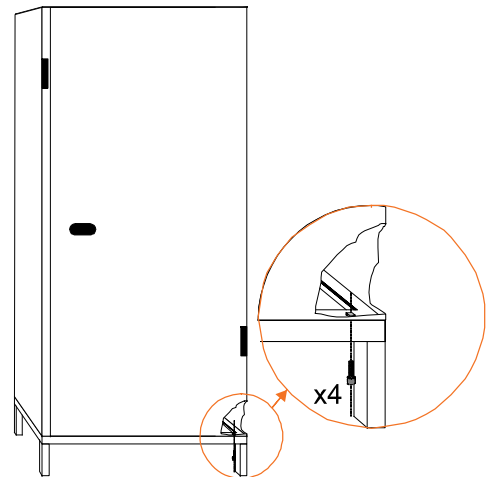

Fig. C 8 – Correct method to install the base module

The air conditioner must be placed vertically on the base module, maintaining a parallel position, avoiding having the load concentration on one small area (see figure below).

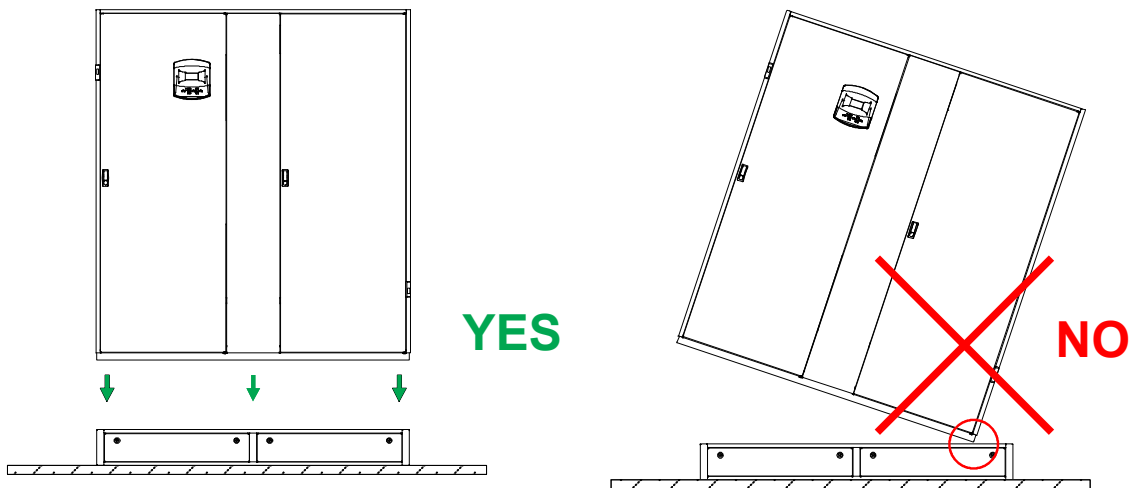
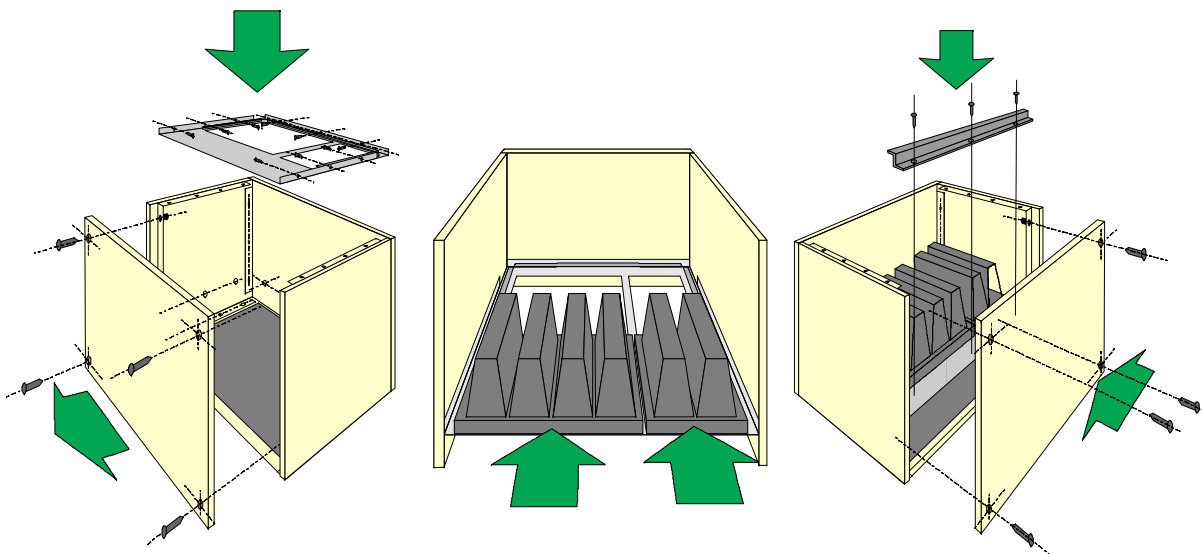

Fig. C 9 – High efficiency filters



Dimensional Data/Connections

Fig. C 10 – New air module

Liebert® HPM S0F ... 2G

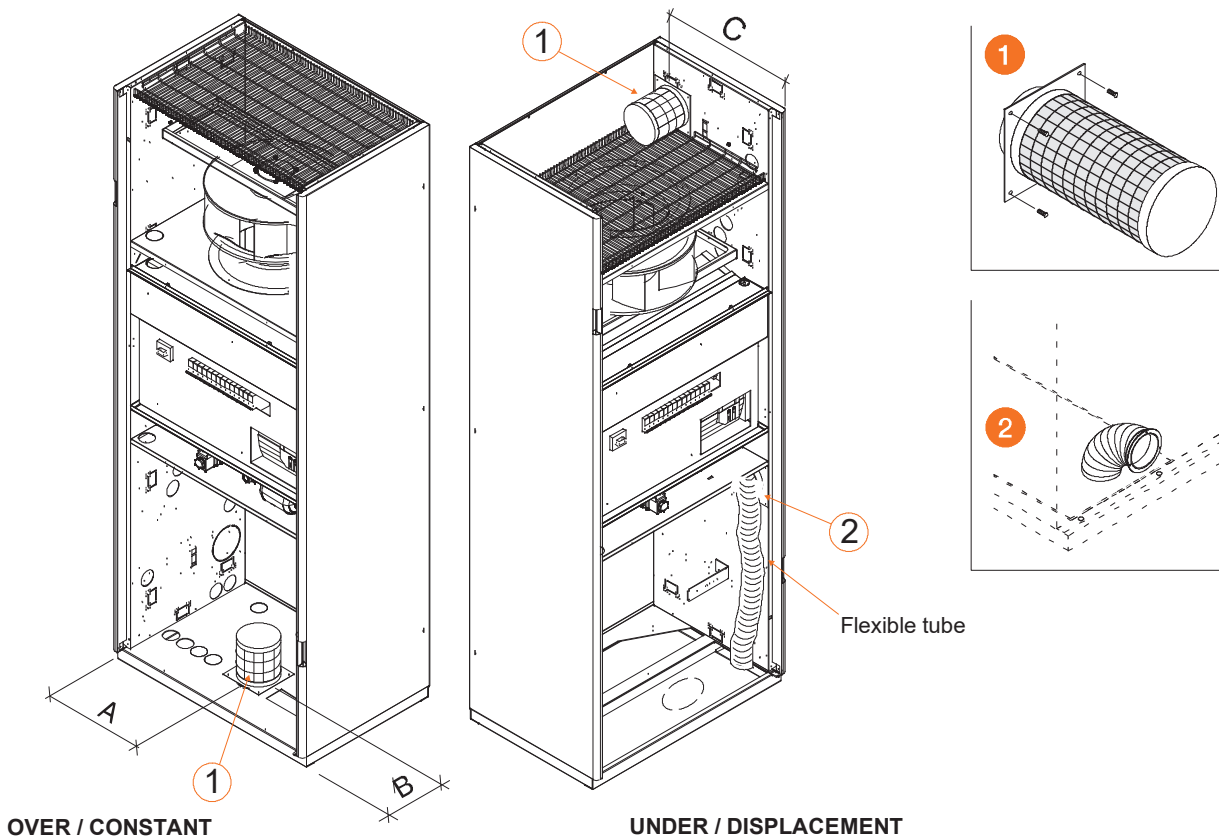

Models	A	B	C
S0F	185	310	320
S0H-1A-1D	375	190	420
S1E-1G-2E-2G	155	450	660

Fig. C 11 – Supply cable path

Liebert® HPM S0F...2G

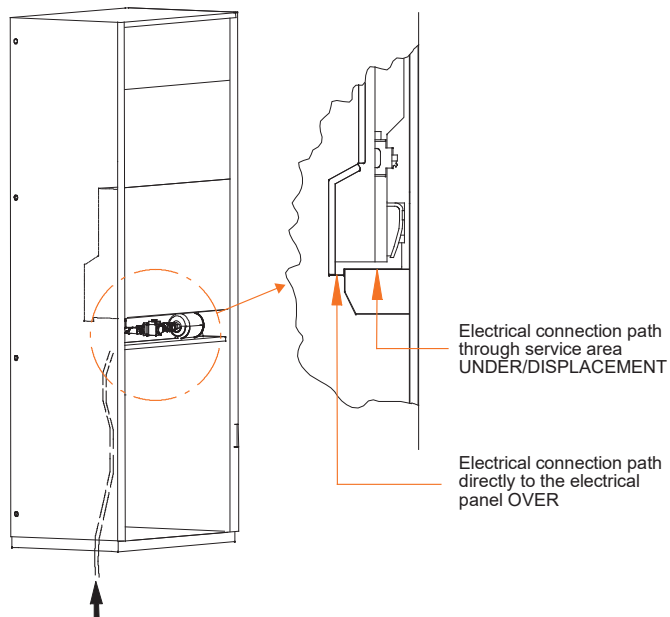

Dimensional Data/Connections

Packing

Fig. 12k Packing standard

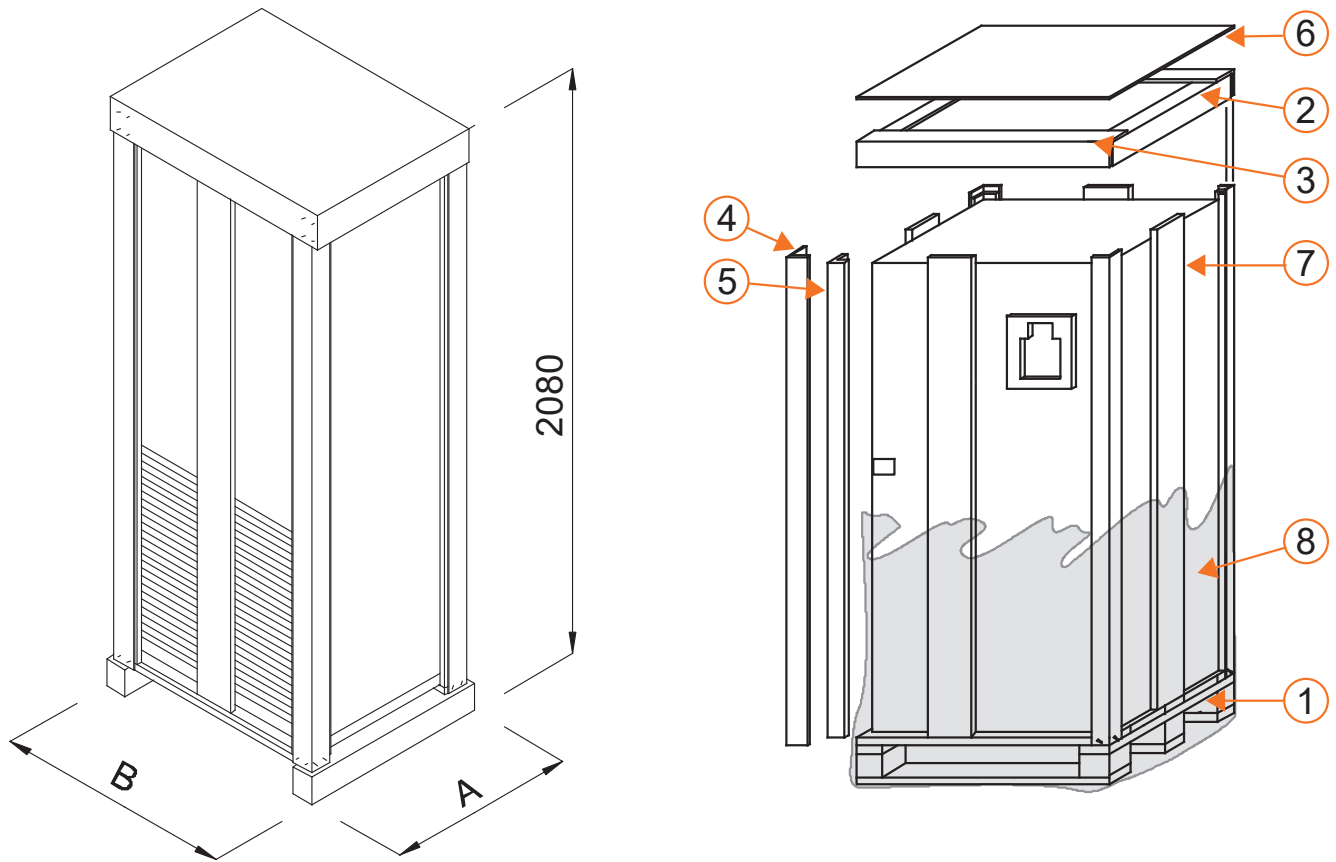

The air conditioners are usually packed on a wooden pallet (1), with shockproof angle pieces in pressed cardboard (2, 3, 4)/polystyrene (5), panels in cardboard (6)/polystyrene (7) and flexible polythene film (8).

Tab. 12b - Packing depth (A)

MODELS	Dimensions (mm)	
	A	B
S0F	480	830
S0H - 1A - 1D	580	830
S1E - 1G - 2E - 2G	830	

Dimensional Data/Connections

Fig. D1 - Refrigerant, water and electrical connections Liebert® HPM S0F - Plan view

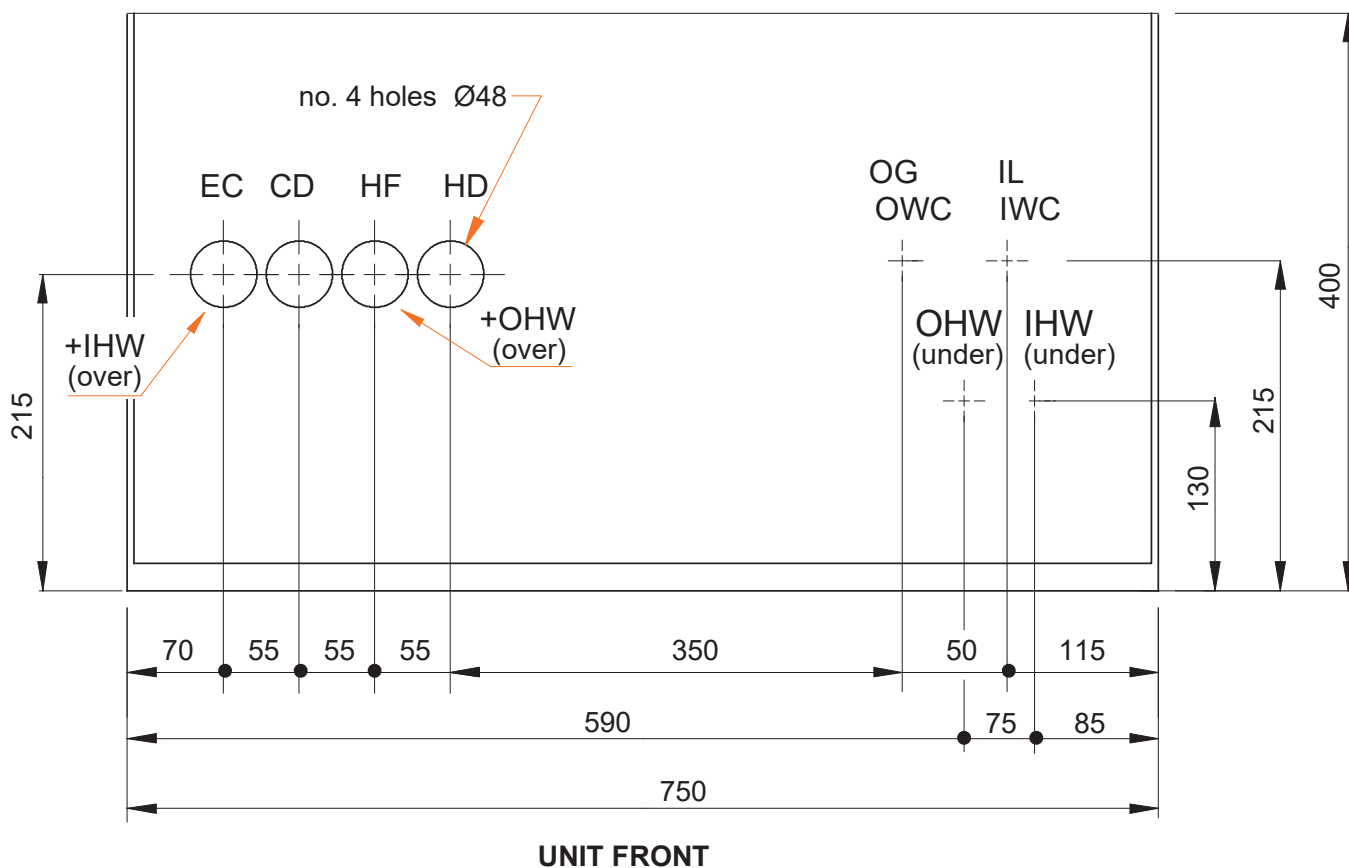

Unit Connection		Version	
		A	W
IL	Refrigerant liquid line inlet *	OD 12 mm	-
OG	Refrigerant gas line outlet *	OD 12 mm	-
IWC	Water to condenser inlet - ISO 7/1	-	Rp ½
OWC	Water from condenser outlet - ISO 7/1	-	Rp ½
IHW	Hot water inlet (opt.)	OD 16 mm	
OHW	Hot water outlet (opt.)	OD 16 mm	
CD	Condensate drain	ID 20 mm	
HF	Humidifier feed (opt.) - ISO 7/1	R ½	
HD	Humidifier drain (opt.)	ID 22 mm	
EC	Electrical power supply	Hole Ø 48 mm	

* Connection size only. The dimension of the connecting pipe depends on unit model and refrigerant, see see Tab. c on para. 4.1.2.

Dimensional Data/Connections

Fig. D2 - Refrigerant, water and electrical connections Liebert® HPM S0H - 1D - Plan view

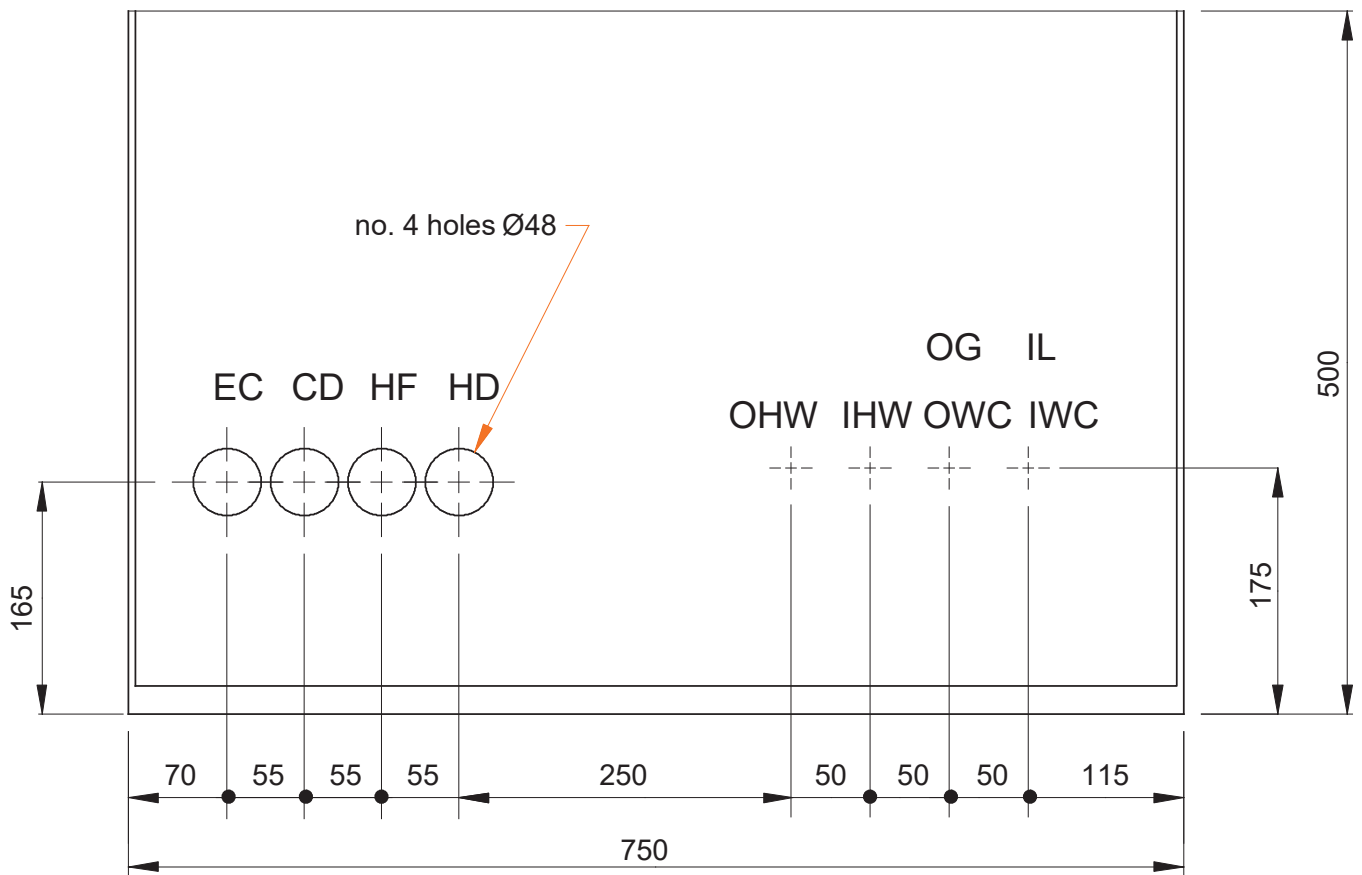

Unit Connection		Version	
		A	W
IL	Refrigerant liquid line inlet *	OD 12 mm	-
OG	Refrigerant gas line outlet *	OD 16 mm	-
IWC	Water to condenser inlet - ISO 7/1	-	Rp 3/4
OWC	Water from condenser outlet - ISO 7/1	-	Rp 3/4
IHW	Hot water inlet (opt.)	OD 16 mm	
OHW	Hot water outlet (opt.)	OD 16 mm	
CD	Condensate drain	ID 20 mm	
HF	Humidifier feed (opt.) - ISO 7/1	R 1/2	
HD	Humidifier drain (opt.)	ID 22 mm	
EC	Electrical power supply	Hole Ø 48 mm	

* Connection size only. The dimension of the connecting pipe depends on unit model and refrigerant, see *Tab. c* on *para. 4.1.2*.

Dimensional Data/Connections

Fig. D3 - Refrigerant, water and electrical connections Liebert® HPM S1E - 2G

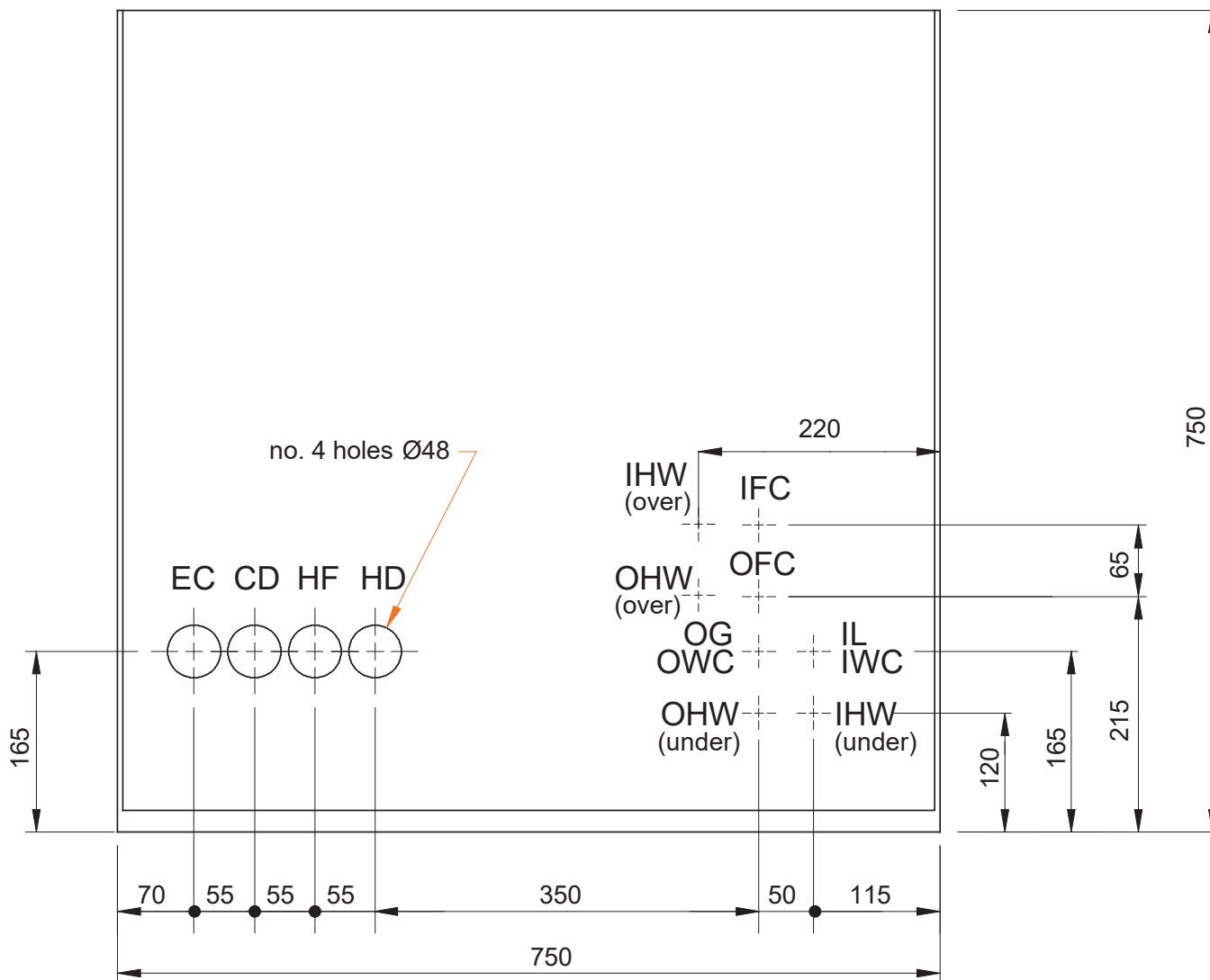

Unit Connection		Version				
		A	W	D	H	F
IL	Refrigerant liquid line inlet *	OD 16 mm	-	OD 16 mm	-	-
OG	Refrigerant gas line outlet *	OD 18 mm	-	OD 18 mm	-	-
IWC	Water to condenser inlet - ISO 7/1	-	Rp ¾	-	Rp ¾	-
OWC	Water from condenser outlet - ISO 7/1	-	Rp ¾	-	Rp ¾	-
IHW	Hot water inlet (opt.)	OD 18 mm				
OHW	Hot water outlet (opt.)	OD 18 mm				
IFC	Water inlet to Freecooling/Dualfluid coil ISO 7/1	-	-	Rp 1		
OFC	Water outlet from Freecooling/Dualfluid coil ISO 7/1	-	-	Rp 1		
CD	Condensate drain	ID 20 mm				
HF	Humidifier feed (opt.) --- ISO 7/1	R ½				
HD	Humidifier drain (opt.)	ID 22 mm				
EC	Electrical power supply	Hole Ø 48 mm				

* Connection size only. The dimension of the connecting pipe depends on unit model and refrigerant, see see *Tab. c on para. 4.1.2.*

Dimensional Data/Connections

Fig. D4 - Refrigerant, water and electrical connections Liebert® HPM S0H - 1D - Plan view

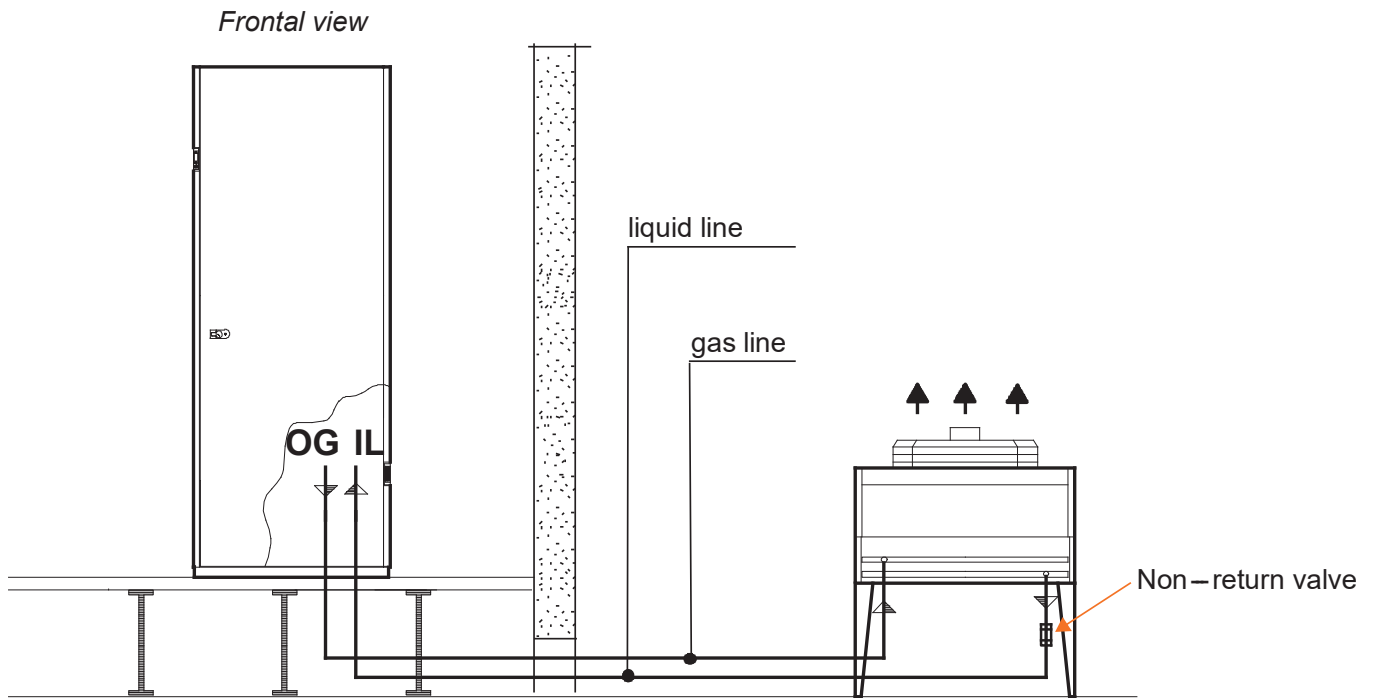



IL	Refrigerant pipe inlet
OG	Refrigerant pipe outlet

Notes: Recommended diameters see Tab. c on para. 4.1.2.

STANDARD PIPE DIAMETERS (Valid for equivalent lengths up to 50 m)		
MOD.	copper tube external diameter x thickness [mm]	
	R410A	
	Gas	Liquid
S0F	10 X 1	10 X 1
S0H	12 X 1	12 X 1
S1A	12 X 1	12 X 1
S1D	14 X 1	14 X 1
S1E	14 X 1	14 X 1
S1G	16 X 1	16 X 1
S2E	18 X 1	16 X 1
S2G	22 X 1.5	18 X 1

Dimensional Data/Connections

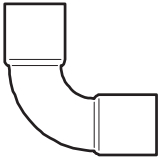
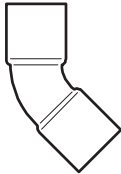
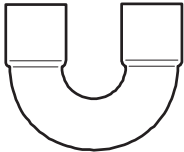
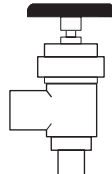
Tab. e - Equivalent lengths (m) of: curves, shut-off and non-return valves

Nominal diameter (mm)					
	90°	45°	180°	90°	
12	0.50	0.25	0.75	2.10	1.90
14	0.53	0.26	0.80	2.20	2.00
16	0.55	0.27	0.85	2.40	2.10
18	0.60	0.30	0.95	2.70	2.40
22	0.70	0.35	1.10	3.20	2.80
28	0.80	0.45	1.30	4.00	3.30

Tab. b - Condenser positioning

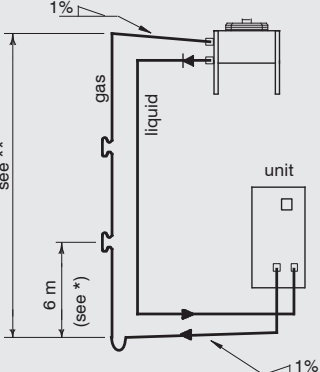
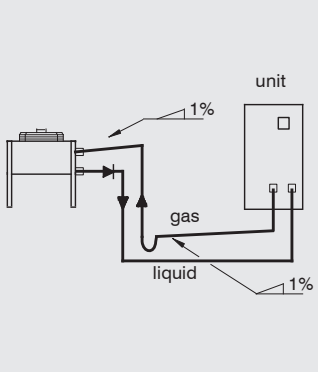
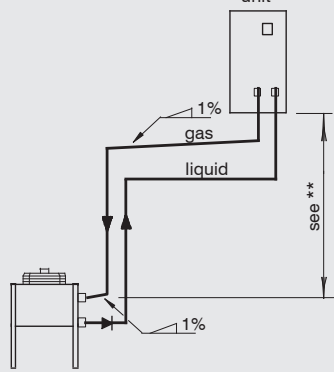
CONDENSER POSITION		CONDENSER ABOVE CONDITIONER	CONDENSER AND CONDITIONER AT SAME LEVEL	CONDENSER BELOW CONDITIONER (not recommended)	
INSULATION	gas	int.	necessary	necessary	necessary
		ext.	only for aesthetic reasons	only for aesthetic reasons	only for aesthetic reasons
	lig.	int.	absolutely not	not necessary	no (expose to cold underfloor air)
		ext.	only for aesthetic reasons	only if exposed to sun	only if exposed to sun
LAYOUT					

Notes

- (a) Check valve required at the condenser outlet. Follow the valve manufacturer indication for orientation and position.
- (b) Oil traps every 6 m of vertical piping. Create an oil trap also on the horizontal discharge line before each lift.
- (c) Max height difference between room unit and remote condenser, see *Chapter 1.11, tab. a*

Silencing cartridges for supply hoods

See *Chap. 7*

Special Cartridges

See *Chap. 7*

Heating-Reheat and humidity control

See *Chap. 8*

High efficiency filters

See *Chap. 9*

Filter holding duct

See *Chap. 9*

Clogged filter alarm

See *Chap. 9*

Fresh air kit

See *Chap. 9*

Humidifier

See *Chap. 11*

Delivery plenum with frontal airflow for Over models

See *Chap. 12*

Base modules

See *Chap. 12*

Intake and delivery hoods

See *Chap. 12*

Base frames

See *Chap. 12*

Special packing

See *Chap. 12*

Flooding alarm (Liquistat)

The flooding alarm detects the presence of water or of any other conductive liquid and, opening a circuit, activates an alarm. There are no moving parts and it is not subject to dirt or vibration. Up to 5 sensors can be connected to the same flooding alarm device to control many points in the room. The alarm device is supplied with a sensor. Additional sensors can be ordered separately.

Smoke alarm (Smokestat)

A smoke alarm can be installed to stop the conditioning system when the presence of smoke in the intake air is perceived. This is an optical smoke detector (it uses the Tyndall effect), which absorbs very low current (100 mA) and is absolutely insensitive to light or wind.

Fire alarm (Firestat)

In some applications the fire regulations require the installation of an alarm device (Firestat) which deactivates the air conditioner when the intake air temperature is too high.

Automatic condensate pump

The **Liebert® HPM**'s condensate drain piping can be connected to a pump complete with a flow cutout that permits the pump to stop and reset automatically.

Tab. 13a - Features of the automatic pump for condensate discharge

water flow	[l/s]	0.083	0.167	0.250	0.333
available head	[kPa]	20	19	18	14

14

Refrigerant Circuits

Fig. 14.1 - Refrigerant diagram Liebert® HPM S0F-S2G A (R410A)

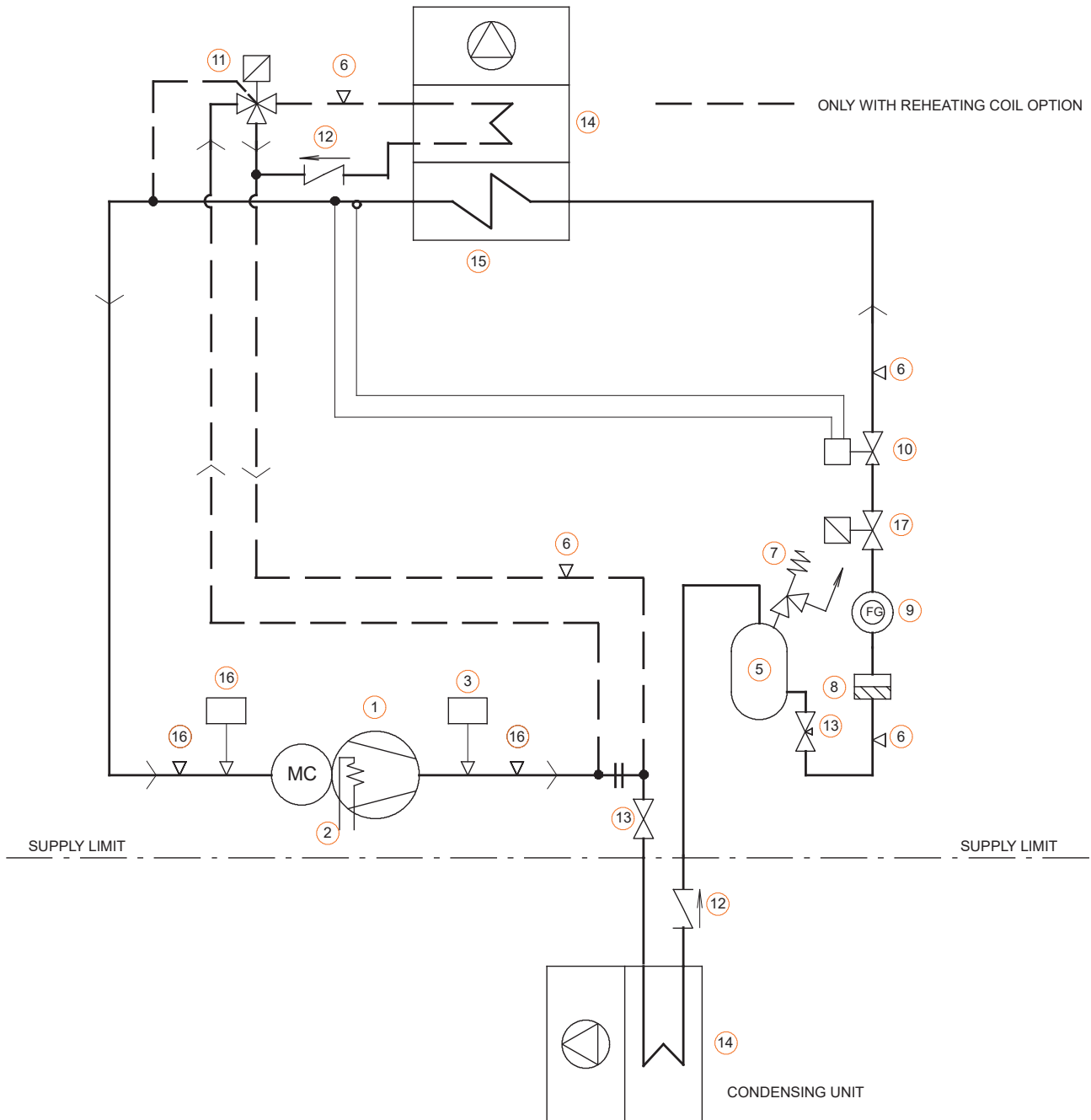

Pos.	DESCRIPTION
1	Compressor
2	Crankcase heater
3	High pressure switch (HP)
4	Air cooled condenser
5	Liquid receiver
6	Access valve (5/16")
7	Safety valve
8	Filter dryer
9	Sight glass

Pos.	DESCRIPTION
10	Thermostatic expansion valve
11	Hot gas solenoid valve (optional)
12	Check valve
13	Shut-off valve
14	Reheating coil (optional)
15	Evaporator
16	Low pressure transducer
17	Shut-off solenoid valve

Refrigerant and Hydraulic Circuits

Fig. 14.2 - Refrigerant diagram Liebert® HPM S0F-S2G W (R410A)

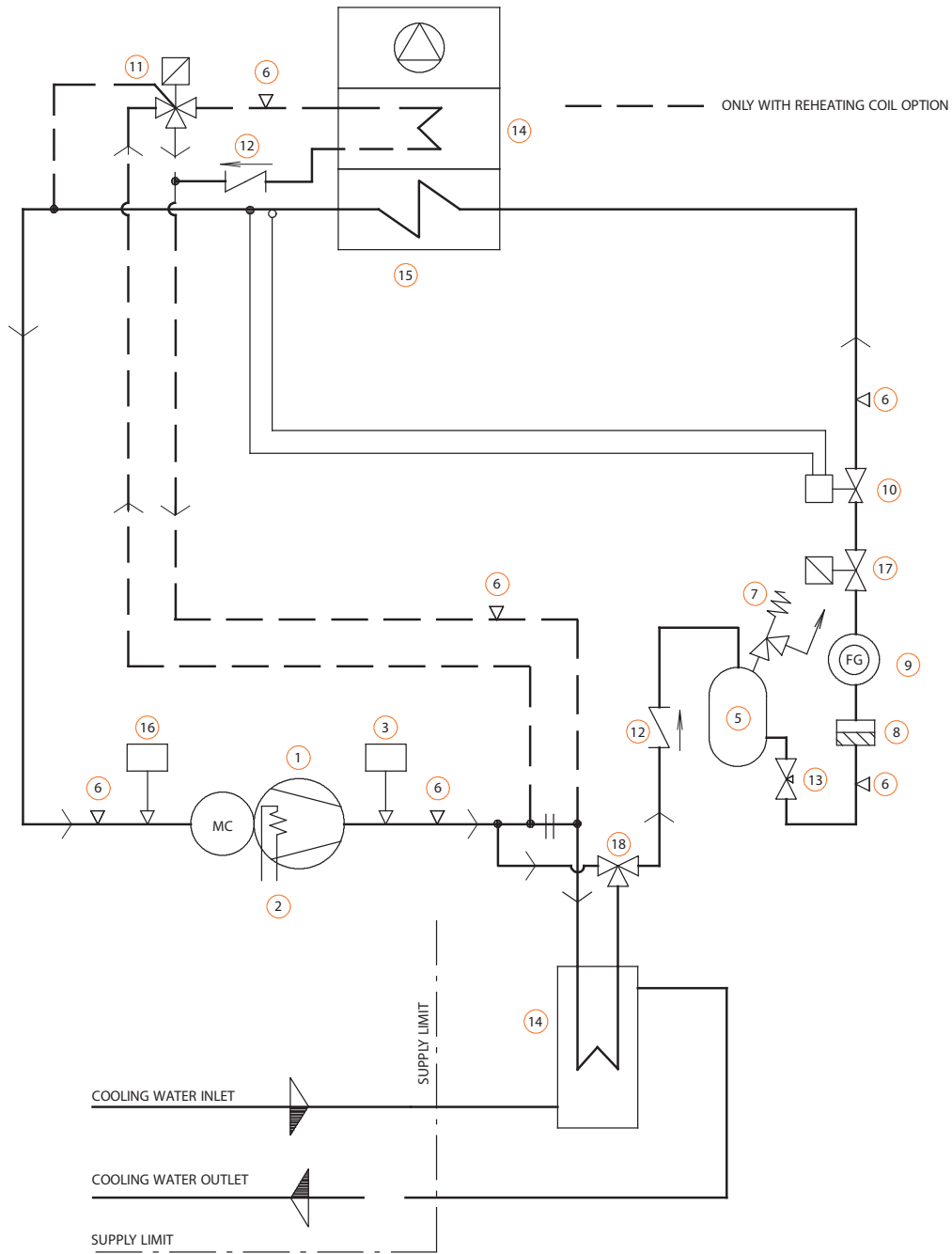

Pos.	DESCRIPTION
1	Compressor
2	Crankcase heater
3	High pressure switch (HP)
4	Water cooled condenser
5	Liquid receiver
6	Access valve (5/16")
7	Safety valve
8	Filter dryer
9	Sight glass

Pos.	DESCRIPTION
10	Thermostatic expansion valve
11	Hot gas solenoid valve (optional)
12	Check valve
13	Shut-off valve
14	Reheating coil (optional)
15	Evaporator
16	Low pressure transducer
17	Shut-off solenoid valve
18	Head pressure control valve

Refrigerant and Hydraulic Circuits

Fig. 14.3 - Refrigerant diagram Liebert® S0F-S2G KA (R410A)

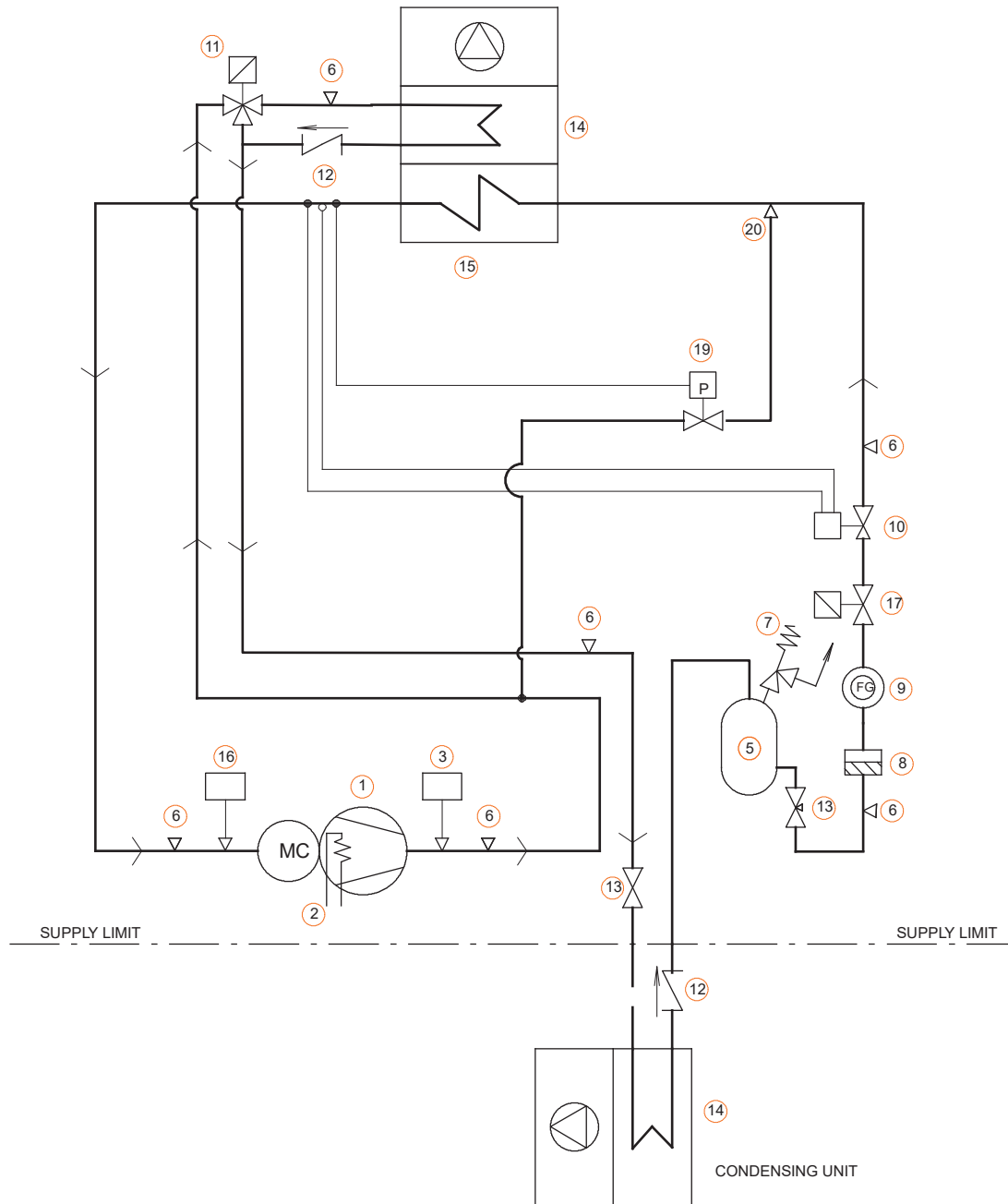

Pos.	DESCRIPTION
1	Compressor
2	Crankcase heater
3	High pressure switch (HP)
4	Air cooled condenser
5	Liquid receiver
6	Access valve (5/16")
7	Safety valve
8	Filter dryer
9	Sight glass
10	Thermostatic expansion valve

Pos.	DESCRIPTION
11	3-way hot gas modulating valve
12	Check valve
13	Shut-off valve
14	Reheating coil
15	Evaporator
16	Low pressure transducer
17	Shut-off solenoid valve
18	-
19	Hot gas valve injection
20	Hot gas injector

Refrigerant and Hydraulic Circuits

Fig. 14.4 - Refrigerant diagram Liebert® S0F-S2G KW (R410A)

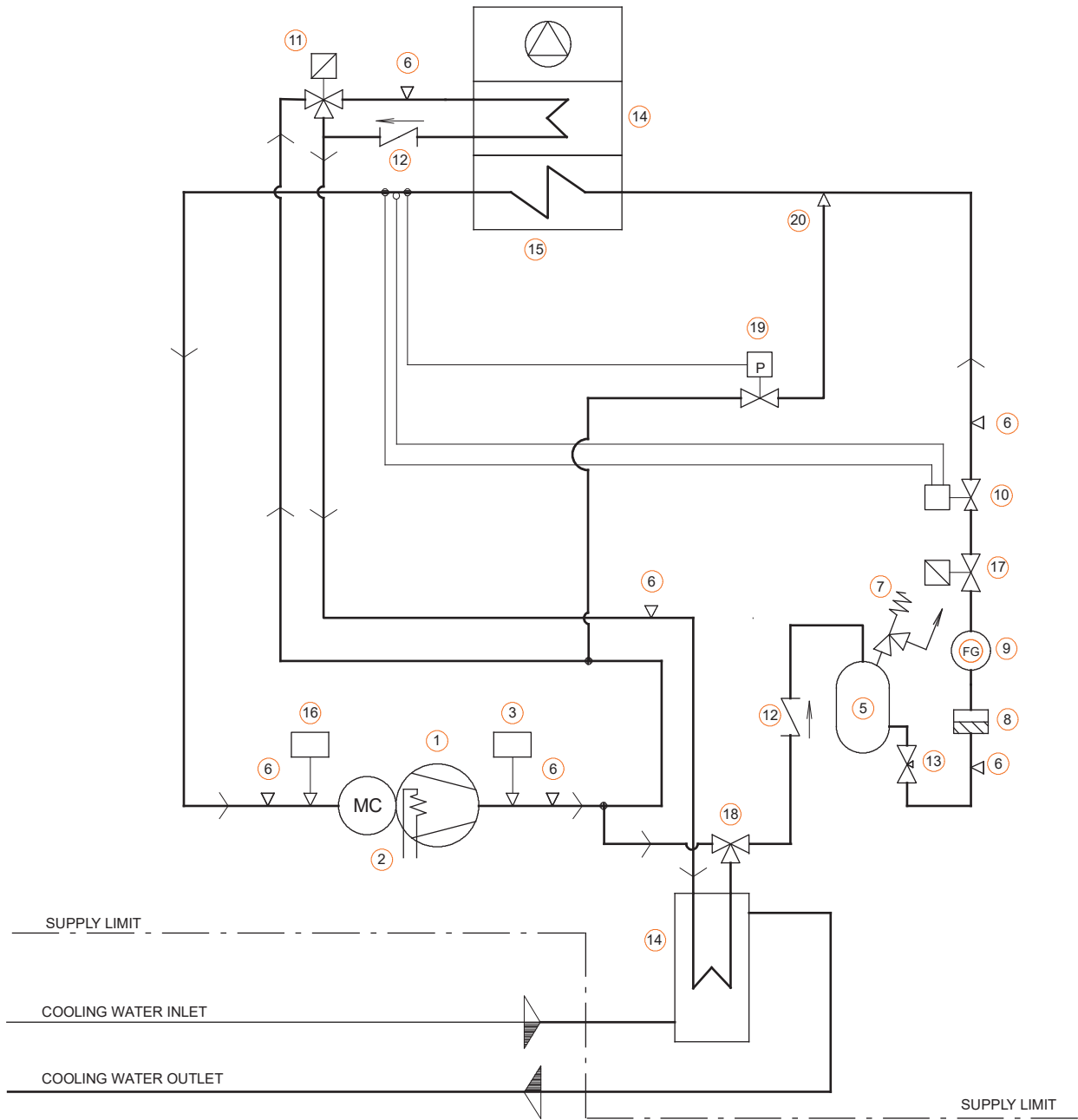

Pos.	DESCRIPTION
1	Compressor
2	Crankcase heater
3	High pressure switch (HP)
4	Water cooled condenser
5	Liquid receiver
6	Access valve (5/16")
7	Safety valve
8	Filter dryer
9	Sight glass
10	Thermostatic expansion valve

Pos.	DESCRIPTION
11	3-way hot gas modulating valve
12	Check valve
13	Shut-off valve
14	Reheating coil
15	Evaporator
16	Low pressure transducer
17	Shut-off solenoid valve
18	Head pressure control valve
19	Hot gas valve injection
20	Hot gas injector



Fabbricante - Manufacturer - Hersteller - Fabricant - Fabricante Fabricante - Tillverkare - Fabrikant - Valmistaja - Produzent Fabrikant
- Κατασκευαστής - Producent
Vertiv S.r.l. - Zona Industriale Tognana
Via Leonardo da Vinci, 16/18 - 35028 Piove di Sacco - Padova (Italy)

Il Fabricante dichiara che questo prodotto è conforme alle direttive Europee:

The Manufacturer hereby declares that this product conforms to the European Union directives:

Der Hersteller erklärt hiermit, dass dieses Produkt den Anforderungen der Europäischen Richtlinien gerecht wird: Le Fabricant déclare que ce produit est conforme aux directives Européennes:

El Fabricante declara que este producto es conforme a las directivas Europeas:

O Fabricante declara que este produto está em conformidade com as directivas Europeias: Tillverkare försäkrar härmed att denna produkt överensstämmer med Europeiska Unionens direktiv: De Fabrikant verklaart dat dit produkt conform de Europese richtlijnen is:

Vaimistaja vakuuttaa täten, että tämä tuote täyttää seuraavien EU-direktiivien vaatimukset: Produzent erklærer herved at dette produktet er i samsvar med EU-direktiver:

Fabrikant erklærer herved, at dette produkt opfylder kravene i EU direktiverne:

Ο Κατασκευαστής δηλώνει ότι το παρόν προϊόν είναι ΑτασάευασμΥνο σύμφωνα με τις οδηγίες της Ε.Ε.:

2006/42/EC; 2014/30/EU; 2014/35/EU; 2014/68/EU; 2011/65/EU; EU/2015/863



VertivCo.com | Vertiv - EMEA, via Leonardo Da Vinci 16/18, Zona Industriale Tognana, 35028 Piove di Sacco (PD) Italy, Tel: +39 049 9719 111, Fax: +39 049 5841 257

© 2024 Vertiv Co. All rights reserved. Vertiv, the Vertiv logo and Vertiv Liebert HPM-S are trademarks or registered trademarks of Vertiv Co. All other names and logos referred to are trade names, trademarks or registered trademarks of their respective owners. While every precaution has been taken to ensure accuracy and completeness herein, Vertiv Co. assumes no responsibility, and disclaims all liability, for damages resulting from use of this information or for any errors or omissions. Specifications are subject to change without notice.

Liebert® HPM-S - PD - 273492MAN_ENG - 03.04.2024