



Liebert[®] PCW

Chilled Water Room Cooling Units

User Manual

English, 10012648MAN_ENG, rev. N.2 - 30.04.2024

This document, written in English, is the original version

Contents

1. Safety	1	8. Assembly and Positioning	55
1.1 Conventions	1	8.1 Safety Instructions	55
1.2 General Instructions	1	8.2 Overview	55
1.3 Personal Protective Equipment	2	8.3 Assembling an Extended Upflow Unit	57
1.4 Residual Risks	2	8.4 Assembling an Extended Downflow Unit	60
2. Digit Nomenclature	5	8.5 For Downflow units - Arranges the drain piping	63
3. Intended Use	7	9. Installation	65
3.1 Purpose of the unit	7	9.1 Safety Instructions	65
3.2 Assembly	7	9.2 Overview	65
3.3 Heat transfer fluid	7	9.3 Specifications for Site Preparation	67
3.4 Functional Limits	7	9.4 Piping Connections	71
3.5 Space Limits	7	9.5 Electrical connections	75
3.6 Environment	8	9.6 Modbus Connections and Settings	78
4. Reference Norms	9	9.7 Filling the water system	80
5. Description	11	9.8 Final Checks	82
5.1 Versions Overview	12	10. Operation	83
5.2 Structure	14	10.1 Safety Instructions	83
5.3 Cooling System	16	10.2 Power-up	83
5.4 Air System	20	10.3 Start	84
5.5 Electric and Control System	22	10.4 Check the Operation	84
5.6 Modbus Connections	27	10.5 Stop	85
6. Technical Data	29	10.6 Restart	85
6.1 Structure	29	10.7 Teamwork	85
6.2 Water System	30	11. Maintenance	87
6.3 Air System	31	11.1 Safety Instructions	87
6.4 Electrical System	32	11.2 General Instructions	88
6.5 Noise Level	45	11.3 Maintenance Program	89
7. Handling	49	11.4 Draining the water system	92
7.1 Safety Instructions	49	11.5 Replacement of Components	93
7.2 Inspection	49	11.6 Calibrations	98
7.3 Transport with Package	50	12. Troubleshooting	99
7.4 Unpacking	51	13. Dismantling the Unit	101
7.5 Transport without Package	51	13.1 Safety Instructions	101
		13.2 Operations	101

Annexes

Annex A - Chilled water circuit and hot water reheating coil..	103	Annex F - Electrode Humidifier	167
Annex B - Safety Labels	107	Annex G - Infrared Humidifier	175
Annex C - Dimensions and Weights.....	113	Annex H - Ultrasonic Humidifier.....	179
Annex D - Connections.....	131	Annex I - ATS (Automatic Transfer Switch)	183
Annex E - Accessories	157	Annex J - Additional Options	193

Documents supplied with the machine

- User Manual (this document)
- PDX-PCW Control Application - Manual
- Electric Diagrams
- Instruction Leaflet for Transport and Handling (on the packaging)
- Labels with Gravity Center (on the packaging)
- Warranty Certificate

List of Tables with Data by Unit Model

Table 01 - Ambient conditions for storage.....	8
Table 02 - Ambient conditions for operation.....	8
Table 03 - Frames and air distribution.....	29
Table 04 - Coil configuration.....	30
Table 05 - Water valves different pressure.....	30
Table 06 - Cooling system - Glycol mixture correction factors.....	30
Table 07 - Air system - fans number and weight.....	31
Table 08 - Electrical data for cooling only - 400 V / 3ph + N / 50 Hz + Earth.....	33
Table 09 - Electrical data for cooling + heating - 400 V / 3ph + N / 50 Hz + Earth.....	34
Table 10 - Electrical data for cooling + humidification - 400 V / 3ph + N / 50 Hz + Earth.....	35
Table 11 - Electrical data for cooling only - 460 V / 3ph + N / 60 Hz + Earth.....	36
Table 12 - Electrical data for cooling + heating - 460 V / 3ph + N / 60 Hz + Earth.....	37
Table 13 - Electrical data for cooling + humidification - 460 V / 3ph + N / 60 Hz + Earth.....	38
Table 14 - Electrical data for cooling only - 380 V / 3ph + N / 60 Hz + Earth.....	39
Table 15 - Electrical data for cooling + heating - 380 V / 3ph + N / 60 Hz + Earth.....	40
Table 16 - Electrical data for cooling + humidification - 380 V / 3ph + N / 60 Hz + Earth.....	41
Table 17 - Fans electrical data.....	42
Table 18 - Electrical heaters data.....	42
Table 19 - Electrode humidifier electrical data.....	43
Table 20 - Infrared humidifier electrical data.....	44
Table 21 - Condensate pump electrical data.....	44
Table 23 - Sound Power Level [dB] - Downflow Up configuration, High Efficiency EC fan module, max airflow.....	45
Table 24 - Sound Power Level [dB] - Downflow Down configuration, High Efficiency EC fan module, max airflow..	46
Table 25 - Sound Power Level [dB] - Downflow Up Frontal Air Delivery configuration, High Efficiency EC fan module, max airflow.....	47
Table 26 - Sound Power Level [dB] - Upflow Up frontal Delivery configuration High Efficiency EC fan module, max airflow.....	48
Table 27 - Unit weight.....	119

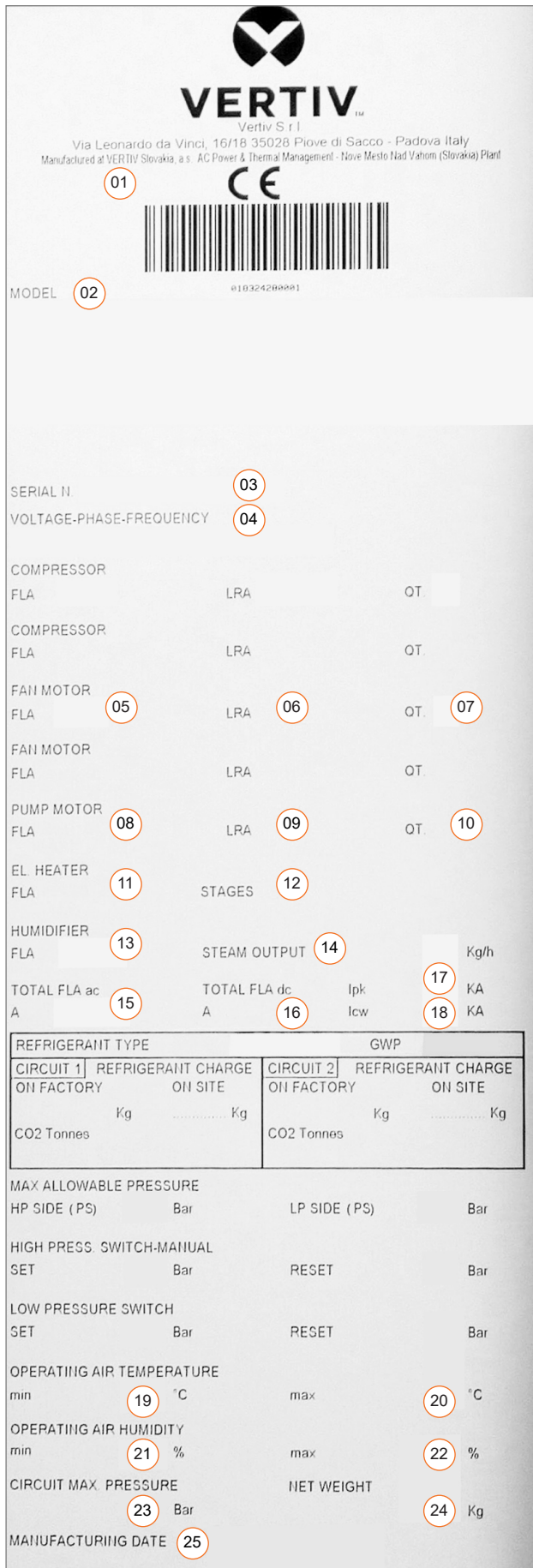

Onboard Label

Please refer to the label placed on the unit for the relevant operating data.

If you need assistance or spare parts, please find the model identification and the serial number on the label.



NOTICE

The data in the manual are referred to standard conditions and can be modified without any advance notice.

The data relevant to the supplied unit are filled in the inboard label (see below an empty facsimile).

Pos.	Description
01	Manufacturing plant
02	Model
03	Serial number
04	Power input
05	Fan Full Load Amps
06	Fan Locked Rotor Amps
07	Fan quantity
08	Pump Full Load Amps
09	Pump Locked Rotor Amps
10	Pump quantity
11	Electrical heater full load Amps
12	Electrical heater stages
13	Humidifier full load Amps
14	Humidifier steam production capacity
15	Unit total full load Amps AC [A]
16	Rated short-time current [kA]
17	Rated peak withstand current
18	Rated short-time current
19	Minimum room operation temperature
20	Maximum room operation temperature
21	Minimum room operation air humidity
22	Minimum room operation air humidity
23	Maximum hydraulic circuit pressure
24	Net weight
25	Manufacturing date

Abbreviations - Acronyms

Item	Definition
ATS	Automatic Transfer Switch
EC	Electronically Commutated [fans]
MCB	Miniature Circuit Breaker
PICV	Pressure Independent Control Valve
STO	Safe Torque Off
Ultracap	Ultra capacitor
UPS	Uninterruptible Power Supply

1. Safety

Content of this chapter

1.1 Conventions.....	1	1.3 Personal Protective Equipment.....	2
1.2 General Instructions.....	1	1.4 Residual Risks.....	2

This chapter gives general safety instructions.

Additional safety warnings, for specific operations, are given in the rest of the manual.

1.1 Conventions



DANGER

Indicates a hazardous situation which, if not avoided, **will** result in death or serious injury.



WARNING

Indicates a hazardous situation which, if not avoided, **could** result in death or serious injury.



CAUTION

Indicates a hazardous situation which, if not avoided, **may** result in minor or moderate injury.



NOTICE

Indicates a property damage message.



ENVIRONMENT

Indicates an environment damage message.

1.2 General Instructions

Intended readers

- This User Manual is intended for transport, installation and maintenance personnel.
- The end user can only switch the unit **ON** and **OFF** and modify the setpoint.

Personnel

- The operations described in this manual must be made by technical staff, expressly authorized in compliance with the regulations in force at the installation site.
- The authorized personnel must be properly trained and qualified, wear appropriate personal protective equipment and use adequate equipment and tools.

Read this manual

- Carefully read the manual before performing any operation on the unit.

Keep this manual

- Keep the manual during the complete life-span of the unit.
- Keep the diagrams provided with the unit (wiring diagram, water circuit,...). They are part of the instructions for use.
- If you move or sell the unit, transfer the manual and the diagrams together with the unit.
- The manuals may be subject to modification. For complete and up-to-date information always consult the specific manual supplied with the unit.

Intended use

- Use the unit only for the purpose it has been designed (see 3. *Intended Use*).
- The manufacturer takes no liability for any improper use of the unit.

Do not modify the unit

- Do not modify the unit without Vertiv™ permission in any way, including the safety devices, the control system and the software.
- The manufacturer takes no liability for any unauthorized modification of the unit.

Warning labels

- Pay attention to the warning labels on the unit.
- Do not remove or cover the labels placed on the unit by the manufacturer.

Lockout-Tagout (LOTO)

Before any intervention on the electrical system or accessing the inner components:

- Lock the disconnection device by a padlock or similar tool.
- Apply on the general disconnecting switch a warning plate.

For units with **ATS** (Automatic Transfer Switch) power supply, see *Annex J - ATS (Automatic Transfer Switch)* for details about the locking procedure.

Safeguards

Raised floor

When you finish the operations on the unit, always remind the following:

- Mount again and fix with screws all the safeguards (panels, grids).
- Close and lock all the doors, if present.
- Place again all the floor panels around and under the unit.
- Never operate the unit without the above mentioned safeguards.

1.3 Personal Protective Equipment

As general rule, always wear the following **PPE** (Personal Protective Equipment):



1.4 Residual Risks

Some operations may involve some residual risk.

Pay attention to the following safety measures when operating inside or near the unit.



Disconnecting switch

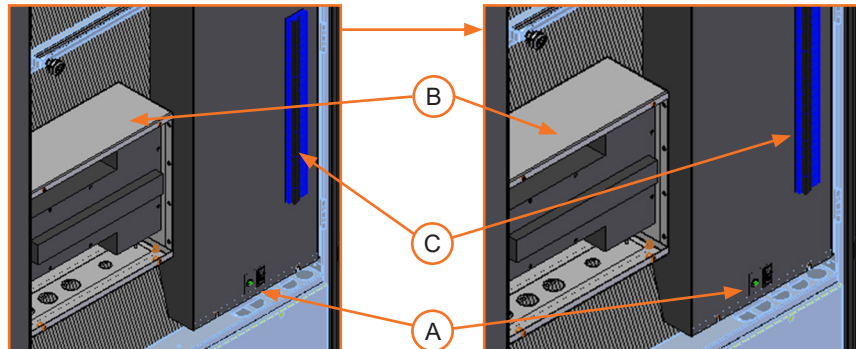

The ON/OFF switch **[A]** on the control panel does not disconnect the unit from the power supply

To disconnect the power supply proceed as following:

- Unscrew the door and open it.
- For units with ATS (optional) power supply open the disconnecting switch **[B]**, see *Annex J - ATS (Automatic Transfer Switch)* for details.
- For units without ATS (Standard) open the disconnecting switch **[C]**.

After you open the door, pay attention to the cable and components that are still energized.

Open the disconnecting switch before removing any protective cover.



Electric and control system

The unit contains potentially lethal voltage in some circuits.
The electric and control panel can retain a stored high-voltage electrical charge for up to **10** minutes.

Risk of arc flash and electric shock.

Can cause injury or death.

General safety measures:

- Only properly trained and qualified personnel may perform repair, maintenance and cleaning.
- The key of the electric panel must be kept by the person responsible for maintenance.
- Always wear the protective equipment prescribed by the local and Vertiv™ regulations.
- It is forbidden to operate on the electrical components without using insulating platforms, or in the presence of water and humidity.

Before working inside the electric and control panels proceed as follows:

1. Open all the local and remote disconnecting switches of the unit.
2. Wait at least 5 minutes.
3. Verify with a voltmeter that the power is **OFF**.



Components at high temperature

The following components are at high temperature:

- electrical heaters
- humidifiers

General safety measures:

- Always wear temperature resistant gloves when operating on the unit.



Sharp elements

Heat exchangers are made of plates and fins, which may have sharp edges and blurs. Also other elements inside the unit may have sharp edges, blurs, splinters and exposed fasteners.

General safety measures:

- Always wear cut resistant gloves.



Automatic startup + rotating elements

This unit operates and restarts automatically.

The fan blades can automatically start rotating without warning at any time during a cooling cycle or after the power is restored after a power failure.

Risk of contact with high-speed, rotating fan blades.

Can cause serious personal injury or death.

Before working inside the unit, removing the fan guards or servicing the fans (speed control, blades, motors) proceed as follows:

- Turn all the disconnecting switches to **OFF**.



Automatic startup + strong air flow

This unit operates and restarts automatically.

The fans may suddenly start blowing out a strong air flow, which may carry particles and small objects from inside the unit.

If the door is opened, the air flow may slam the door closed (Upflow versions only).

Can cause serious personal injury.

General safety measures:

- Wear eyes protection when you need to get close to the unit while it is operating.
- Pay attention to the warning labels on the unit.

Before working on the unit proceed as follows:

- Turn all the disconnecting switches to **OFF**.



Lifting and moving

- Make sure to use transport and lifting equipment rated for the unit dimensions and weight.
- Pay attention to the gravity center and warning labels placed on the unit.
- Make sure that the lifting point is aligned with the gravity center.
- Make reference to *Annex D - Dimensions and Weights* for dimensions, weight and gravity center position.



Handling area

- Never walk or stay below a suspended load.
- The area for handling and moving must be free from obstacles and persons.
- Not authorized personnel must keep at safe distance from the handling area.
- The floor of the handling area must be suitable to bear the weight of the unit and of the moving equipment.

2. Digit Nomenclature

The unit is fully defined by the following digits.

1	2	3	4	5	6	7	8	9	10	11	12	13	14	15	16	17	18	19	20	21	22	23	24	25
---	---	---	---	---	---	---	---	---	----	----	----	----	----	----	----	----	----	----	----	----	----	----	----	----

Dig.	Feature	Value	Description
1 2	Family name	PW	
3 4 5	Model	000	
6	Air discharge	U	Upflow
		H	Downflow Frontal (displacement)
		D	Downflow Up
		E	Downflow Down (in the raised floor)
7	System type	L	Legacy coil
		S	Smart Efficiency coil
		E	Eco coil
		W	Dual Source coil
8	Air flow	E	EC fan - High Efficiency
		P	EC fan - High Power
9	Power supply	3	400 V / 3 ph / 50 Hz + N CE
		T	380-400 V / 3 ph / 60 Hz + N CE
		6	460 V / 3 ph / 60 Hz CE
10	Cooling system	2	CW two way valve
		3	CW three way valve
		P	CW two way valve Pressure independent
11	Humidification	0	None
		H	Infrared humidifier
		U	Ultrasonic humidifier
		S	Electrode humidifier
12	Microprocessor control	0	None
		7	7" touch screen
		F	10" touch screen
13	Heating and re-heating	0	None
		1	Electric heating standard capacity
		2	Electric heating high capacity
		4	Hot water heating
		8	Electric heating standard capacity + hot water heating
14	Air filter	1	ePM10 50%
		2	ePM10 50% + Differential pressure transducer
		3	ePM10 50% + clogged filter

Dig.	Feature	Value	Description
15	Coils and pipes	H	Bottom connectors
		T	Top connectors
		S	Left side connectors
16	Color	1	Black RAL 7021
17	High voltage option	D	Standard Power Supply
		F	Dual Power Supply Parallel
		A	Dual Power Supply with ATS
		G	Dual Power Supply with ATS and Ultracap
18	Package option	0	None
		S	Predisposition for Smart Aisle™ (predisposition for damper sensor, 3 position switch)
		F	Predisposition for Economizer (sensors, predisposition for dampers)
19	Monitoring	G	Predisposition for Smart Aisle + Economizer
		0	None
		1	Monitoring (Modbus IP, BACnet IP, SNMP and HTTP)
20	Options	4	LIFE compatibility
		0	None
		C	Condensate pump
		E	Energy meter
21	Packaging	R	Condensate pump + Energy meter
		P	PLP and Pallet
		C	PLP and wooden crate
22	Water sensor	S	Seaworthy
		0	None
		W	Water temperature sensor IN/OUT
		V	Water temperature sensor IN/OUT and flow meter
23	Special requirements	R	IEC61000-6-3 Compliant
		I	IEC61000-6-4 Compliant
24	Special requirements	E	Free
25		A	Standard Vertiv™
X		Special Vertiv™	

Fan module

The fan module can be delivered separately:

- always for extended height units
- in case of fan module replacement for standard units (with the exception of the 1 bay units)

The fan modules are not available for 1 bay units, since the fan section of these units are integrated with the cabinet structure.

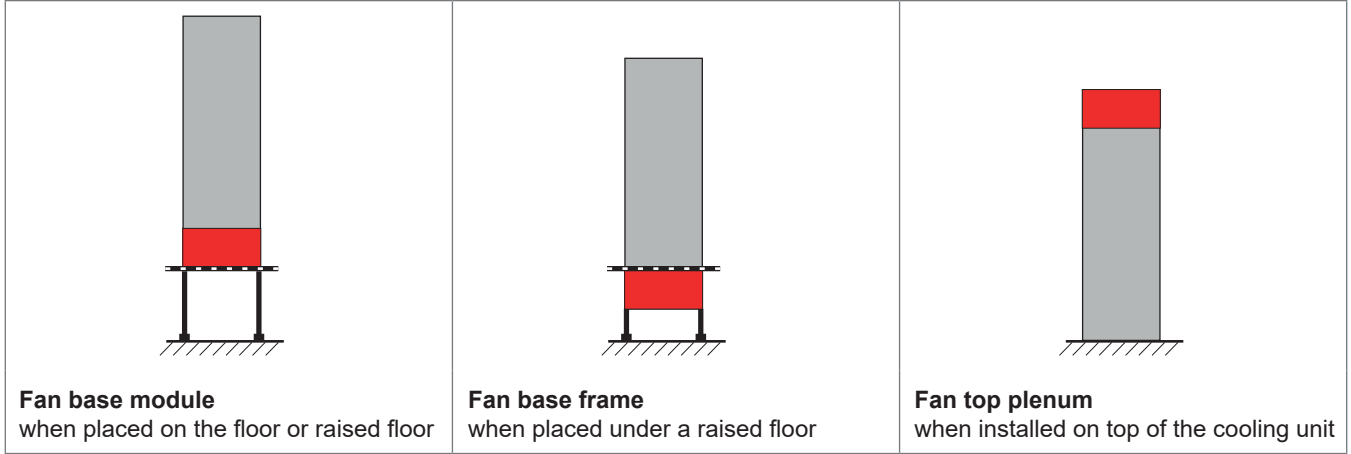

The fan module is fully defined by the following digits.



Dig.	Feature	Value	Description
1 2 3	Fan Module (see the figure above)	BWM	Base fan module
		BFM	Base fan frame
		TPM	Fan top plenum
4 5	Size: nominal length	12	1200 mm
		17	1750 mm
		20	2050 mm
		25	2550 mm
		29	2950 mm
6	Air delivery	S	Standard
		B	Back (fans removal from the front)
		F	Front
7	Fans	E	EC fac advance-HE
		P	EC fac advance-HP

Dig.	Feature	Value	Description
8	Heaters	0	No heaters
		1	Standard capacity
		2	High capacity
9	Packaging	P	PLP and pallet
		C	PLP and wooden crate
		S	Seaworthy
10	Power supply	3	400 v / 3 ph / 50 Hz + N CE
		T	340-400 v / 3 ph / 60 Hz + N CE
		6	460 v / 3 ph / 60 Hz CE
11	Options	0	None
		C	Condensate pump
12	Free digit		
13	Special requirements	A	Standard Vertiv™
		X	Special Vertiv™

3. Intended Use

Content of this chapter

3.1 Purpose of the unit.....	7	3.5 Space Limits.....	7
3.2 Assembly.....	7	3.6 Environment.....	8
3.3 Heat transfer fluid.....	7	3.6.1 Storage conditions.....	8
3.4 Functional Limits.....	7	3.6.2 Operating conditions.....	8

3.1 Purpose of the unit

The **PCW** units have been designed and manufactured for the following purpose:

- Precision air conditioning for indoor use (for data centers, network closets, technological rooms).

3.2 Assembly

The **PCW** units are factory assembled, including all the internal wiring.

The only operation to be made at the installation site are the following:

- Mounting of the fan section (only for the extended versions)
- Electrical connections for power supply
- Water piping connections to the chilled water supply system
- Other optional piping connections (condensate drain, hot water supply system)

See Chapter 5. *Description* for details about the unit structure, versions and optional components.



WARNING

Do not assemble or connect the unit with systems or machines that are different from what is specified in this manual for your unit.

Contact Vertiv™ Technical Support for any question.

3.3 Heat transfer fluid

The heat transfer fluid is chilled water or mixture water + glycol supplied by an external system.

In this document we will use the word “water” in case of water + glycol mixture when not specified differently.

3.4 Functional Limits

See 6. *Technical Data*



WARNING

Risk of components failure or breakage.

Do not use refrigerants, fluids and voltage that are different from what is specified in this manual for your unit.

Contact Vertiv™ Technical Support for any question.

3.5 Space Limits

Overall unit dimensions See *Annex C - Dimensions and Weights*

Clearance Keep a free space around the unit as explained in *9.3.2 Space requirements*.

3.6 Environment



WARNING

Do not use in explosive, acid or any aggressive atmosphere.

3.6.1 Storage conditions

Table 01 - Ambient conditions for storage

Storage environment	Indoor environment, protected against weather agents Clean (no dust), well-ventilated, non-condensing
Ambient temperature	-20°C – +50°C
Ambient humidity	<90% and preventing condensation
Storage time	The total storage time should not exceed six months. If the storage time is longer than six months, then you must check the functionality of sensors and other electronic devices before starting the unit.
Position	Keep the unit vertically upright.

3.6.2 Operating conditions

Table 02 - Ambient conditions for operation

Operating environment	The unit is designed for indoor installation, protected from weather agents, with the following ambient conditions.	
Air returning to the unit inlet (indoors conditions)	Temperature	+18°C — +45°C
	Absolute humidity	5,5 — 11 g steam / kg air
	Relative humidity	20 — 60 %
A lower thermal load will cause inaccurate temperature and humidity control		
Chilled water system	Minimum water inlet temperature	5°C
	Maximum water pressure	16 bar
	Water-Glycol mixture limit	Up to 50% vol.
Hot water system (optional)	Maximum water inlet temperature	85°C
	Maximum water pressure	8,5 bar
Power supply tolerance	Voltage	± 10%
	Frequency	± 2 Hz
See also 9.3.7 <i>Electric system requirements - Power supply variability</i>		

4. Reference Norms

All **Liebert**[®] thermal units are designed, manufactured and tested according to the following directives and standards:

- EU Directives**
- Machine Directive 2006/42/CE
 - PED Directive 2014/68/EU
 - Low Voltage Directive 2014/35/UE
 - EMC Directive 2014/30/UE
 - RoHS II Directive 2011/65/EU
 - RoHS III Directive EU/2015/863

CE Marking and Conformity Declaration

The units are marked "**CE**".
 Each unit is supplied complete with individual test certificate and a certificate of conformity to the European Union Directives.
 See also the last page.



UKCA Marking and Conformity Declaration

The units are marked "**UKCA**".
 Each unit is supplied complete with individual test certificate and a certificate of conformity to the UK Safety Regulations



Performance test norms

- Cooling Capacity according to EN 14511
- Sound Power Level according to ISO 3744

5. Description

Content of this chapter

5.1 Versions Overview.....	12	5.4.5 Condensate tray.....	21
5.1.1 Unit frame.....	12	5.4.6 Condensate pump (optional).....	21
5.1.2 Air distribution.....	12	5.4.7 Sensors and instruments.....	21
5.1.3 Cabinet width.....	13	5.5 Electric and Control System.....	22
5.1.4 Cabinet height.....	14	5.5.1 Standard or dual power supply.....	22
5.1.5 Accessories.....	14	5.5.2 EMC Emission.....	23
5.2 Structure.....	14	5.5.3 Main components.....	24
5.2.1 Standard version.....	14	5.5.4 Disconnecting switches.....	25
5.2.2 Extended version.....	16	5.5.5 Control panel.....	26
5.3 Cooling System.....	16	5.5.6 Ethernet connection.....	26
5.3.1 Circuit versions and operating principle.....	16	5.5.7 Protective functions.....	26
5.3.2 Water coil types.....	17	5.5.8 Fans control.....	26
5.3.3 Water valve types.....	17	5.5.9 Smart Aisle™.....	27
5.3.4 Drain valves.....	18	5.6 Modbus Connections.....	27
5.3.5 Hot water coil (optional).....	19	5.6.1 General description.....	27
5.3.6 Chilled water connection configuration.....	19	5.6.2 Fan management.....	28
5.4 Air System.....	20		
5.4.1 Fans.....	20		
5.4.2 Filters.....	20		
5.4.3 Heating (optional).....	20		
5.4.4 Humidifier (optional).....	21		

NOTE *The images in this manual refer to sample units. Some components may be different for other units but the function remains the same.*

5.1 Versions Overview

5.1.1 Unit frame

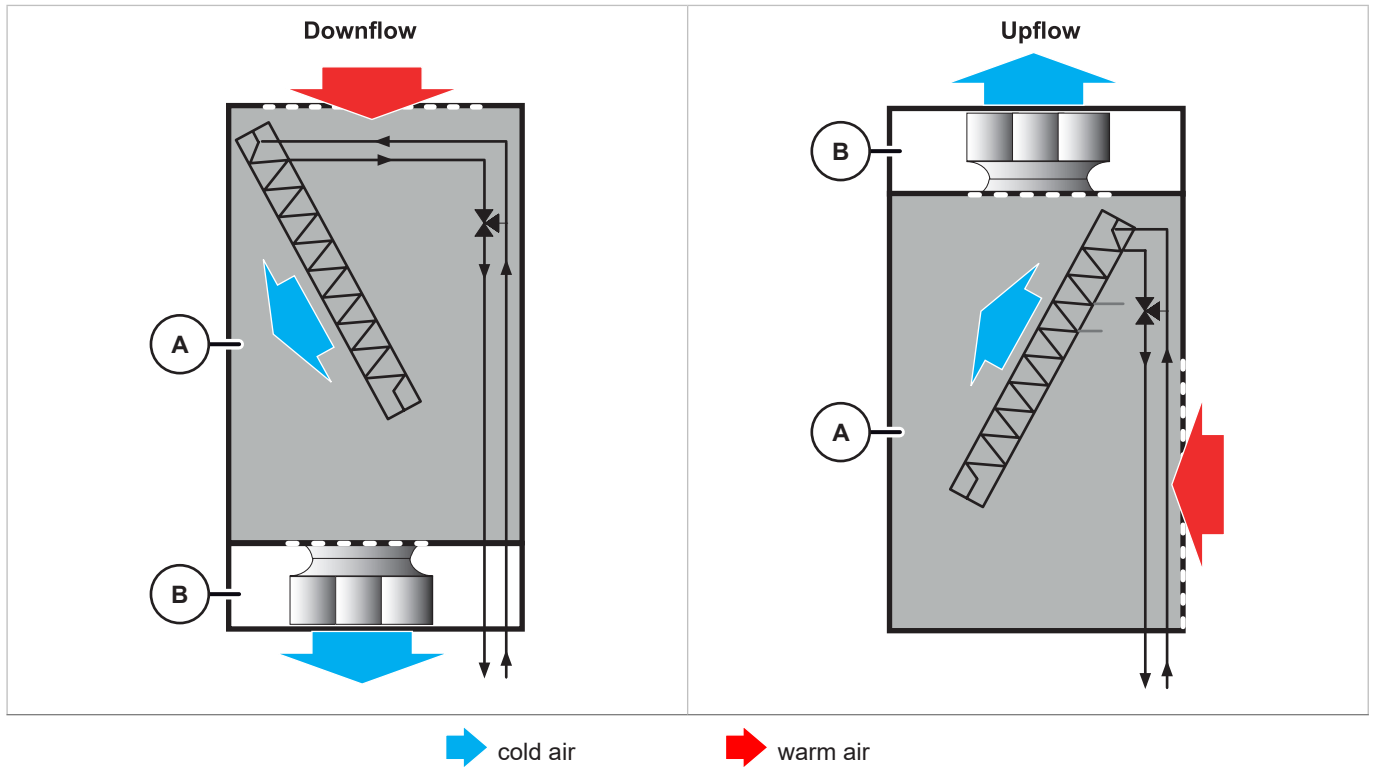

The unit frame is made by the coil section [A] and the fan section [B].

The coil section contains the cooling system of the unit, the electric panel and the control system.

The fan takes the **warm air** from the room into the unit. The air flows through the heat exchange, cools down and blows out again in the room.

The fan section may be placed at the bottom of the coil section (**Downflow** versions) or on top (**Upflow** versions).

The cooling system of the unit is connected on site to the external chilled water supply system.

The unit frames can be combined in different ways to obtain different versions.

Different versions are available also for the water cooling system. (see *Annex A - Chilled water circuit and hot water reheating coil*).

5.1.2 Air distribution

The unit is placed on a raised floor, whereas the unit fan module can be placed under a raised floor.

The air flow direction can be either **Upflow** (fan section on top) or **Downflow** (fan section at the bottom).

The following combinations are available:

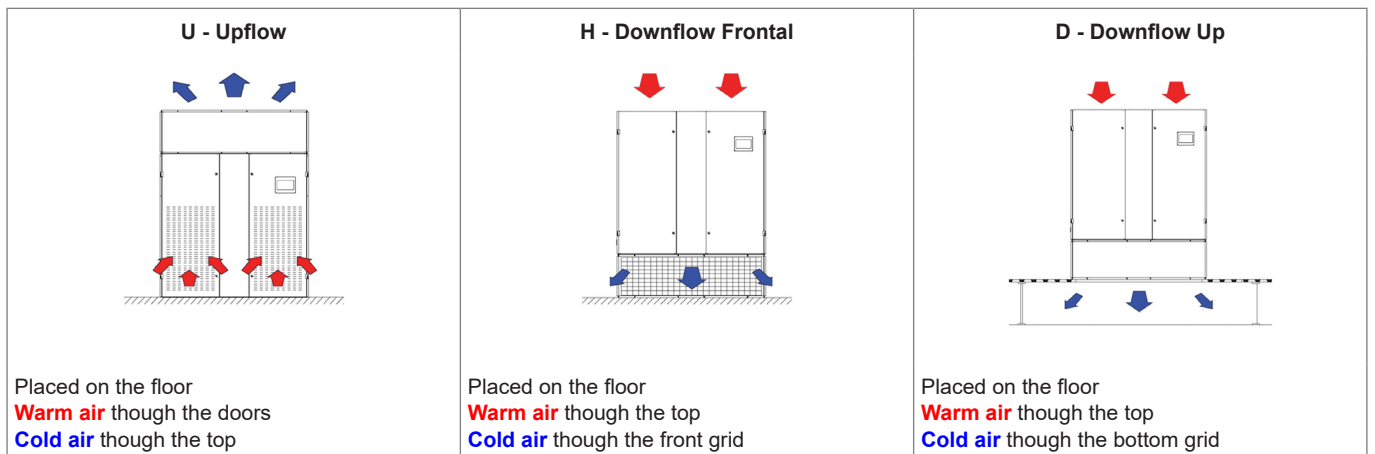

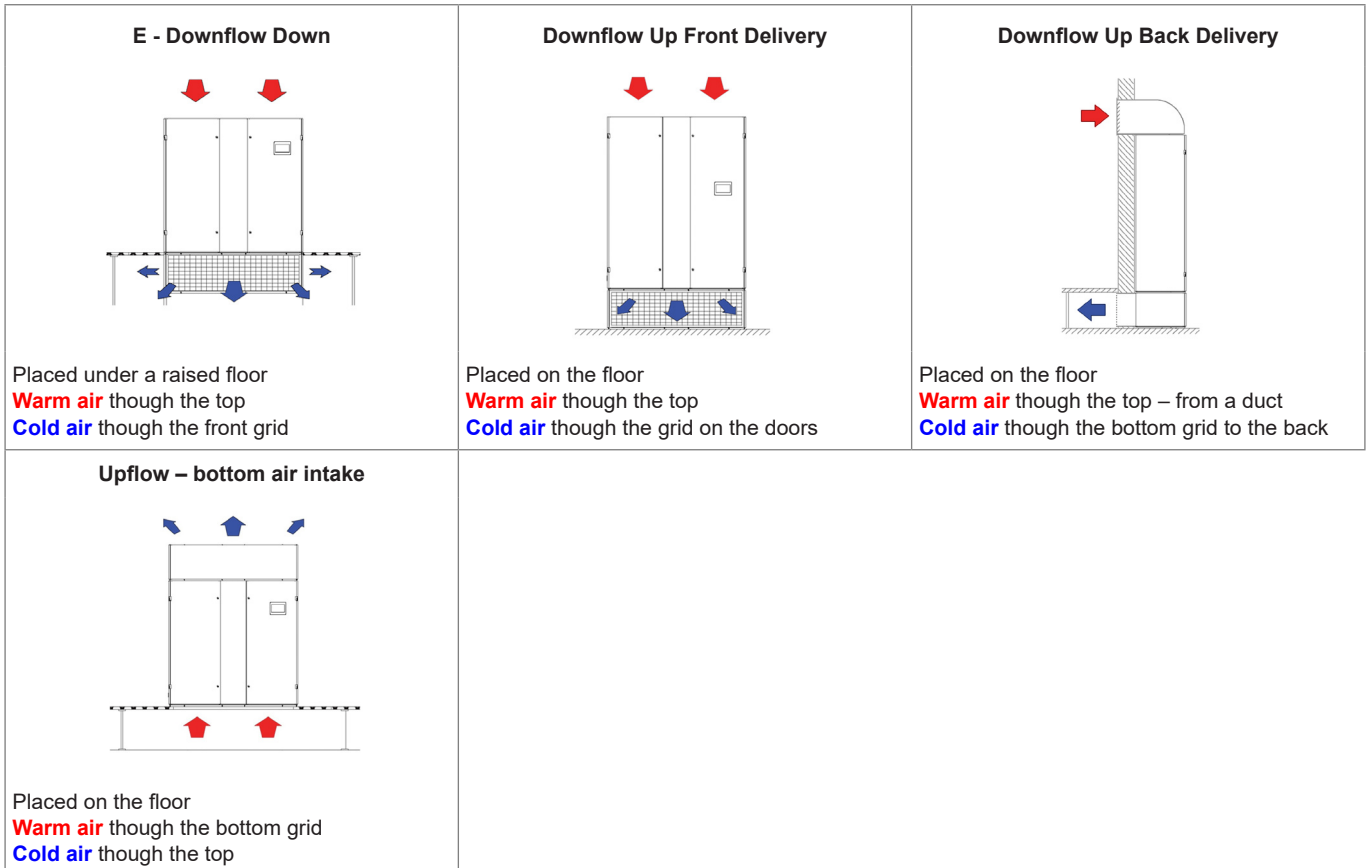

5.1.3 Cabinet width

The units can have the following cabinet size:

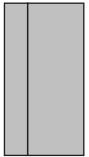
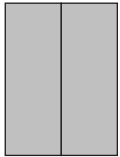
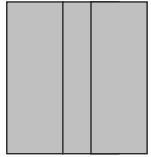
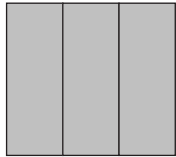
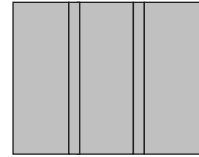
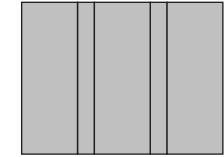
	Frame type	1	2	3	4	5	6	7
	Number of bays	1	1,5	2	2,5	3	3,5	4
Width								
		<p>NOTE In the units of frame type 1 the coil section and the fan section are integrated. In the units with frame types 2, 3, 5, 6 and 7 the coil section and the fan section are separate modules that are assembled together.</p>						

5.1.4 Cabinet height

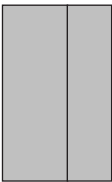
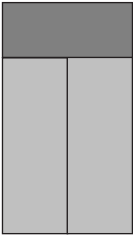
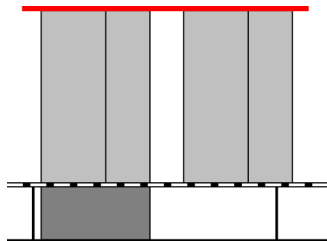
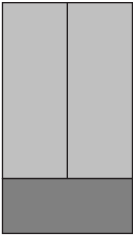
Height	Standard H=1970 mm 	The coil and the fan sections are factory assembled in the same cabinet.
	Extended H=2570 mm Fan module on top of the Coil module 	The coil module and the fan module are delivered separately and must be assembled at the installation site. NOTE <i>The top of an extended version unit placed under a raised floor will be at the same height as the top of a standard unit placed on the floor</i> 
	Extended H=2570 mm Fan module at bottom of the Coil module 	

5.1.5 Accessories

Several accessories are available for the following purposes:

- support and adjustment of the unit height
- different options for air intake (from outdoor, through hoods or plenum, ...)
- noise damping
- high efficiency filters

See *Annex E - Accessories* for details.

5.2 Structure

5.2.1 Standard version

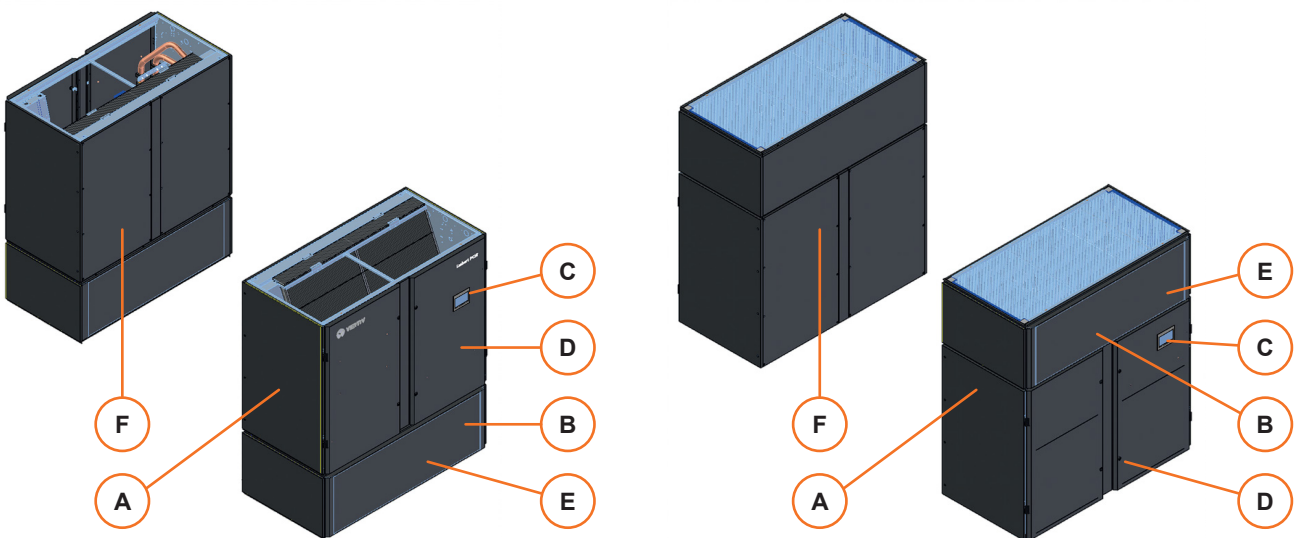

Ref.	Description	Remarks
A	Coil section	The coil section is completely closed by panels and by the door for protection against any contact with electric parts and hot or cold surfaces.
B	Fan section	The fan section is completely closed by panels and grids for protection against any contact with moving parts.
C	Control panel	The unit is usually controlled remotely by a network connection. The control panel is optional and may be placed on the front door or inside the front door.
D	Doors	The doors can be opened only by the proper tool.
E	Fan safeguards	The fixed panels (safeguards) can be removed only by losing the fixing screws.
F	Rear safeguards	

After opening the doors:

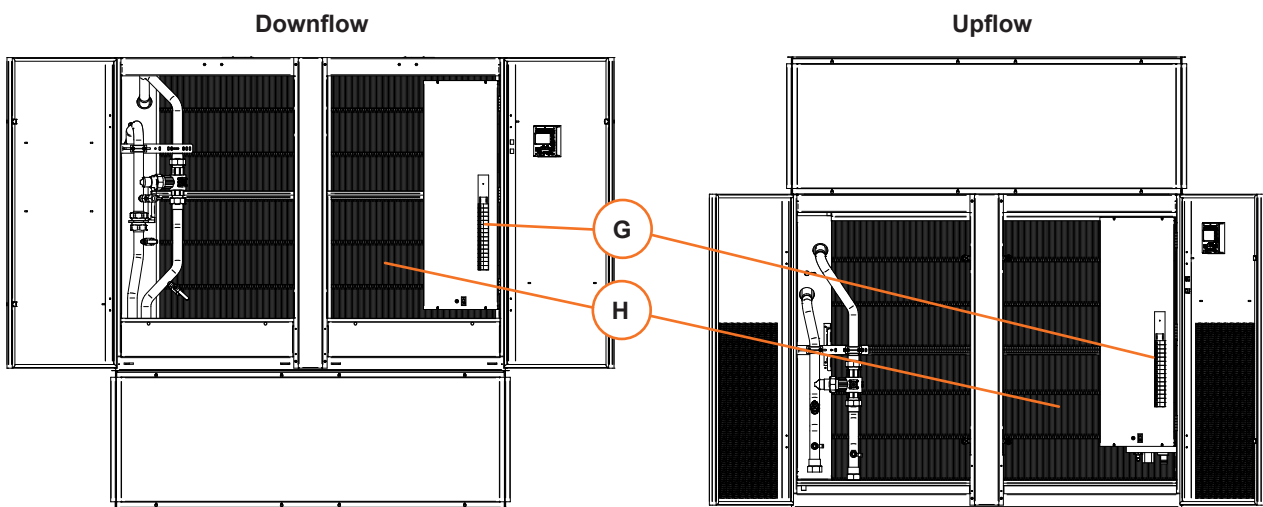

Ref.	Description	Remarks
G	Electric and control panel safeguards	The fixed safeguards can be removed only by losing the fixing screws.
H	Coil compartment	

5.2.2 Extended version

In the **extended versions** the fan section and the coil section are separate modules which must be assembled at the installation site.

The fan module for the extended versions is named differently as shown below.

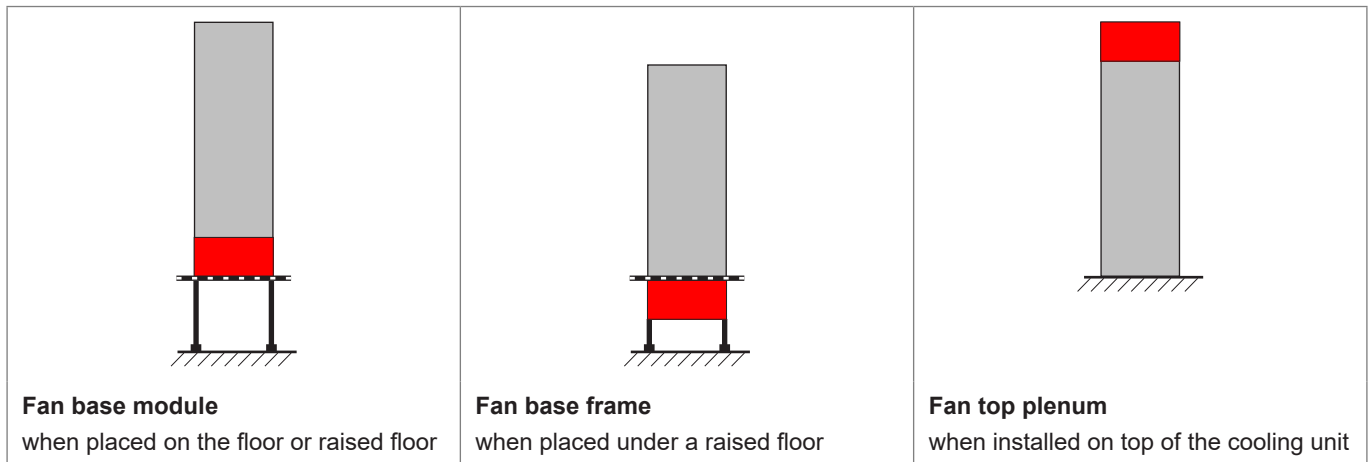

5.3 Cooling System

5.3.1 Circuit versions and operating principle

Single circuits

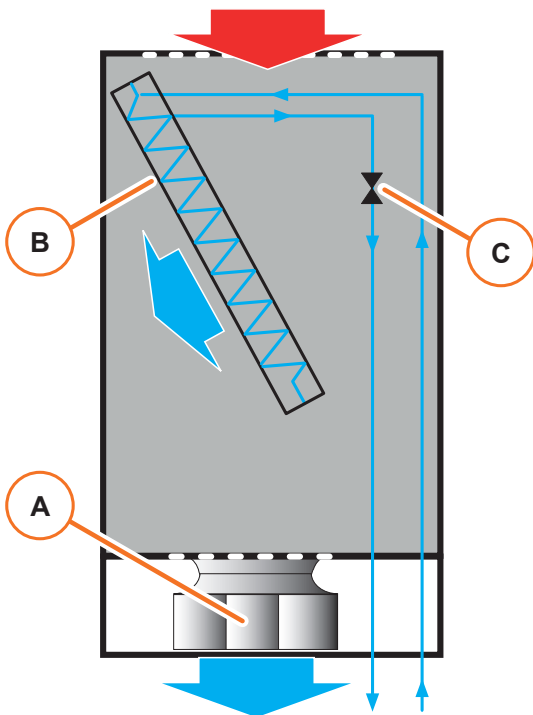

Main components

A Fan

B Water coil

C Water valve

Operating principle

The figure shows a simplified scheme for a **Downflow unit** with single circuit.

Make reference to *Annex A - Chilled water circuit and hot water reheating coils* for details.

The operating principle is the same for all of the models (also including Upflow air distribution and double circuits)

The fan [A] lets the **warm air** coming from the room to flow through the water coil [B].

The water cools down the air, which flows again into the room

The control system operates the opening and closing of water valve [C] at the water outlet in order to control the water flow rate so to maintain the desired operating conditions.

Double circuits

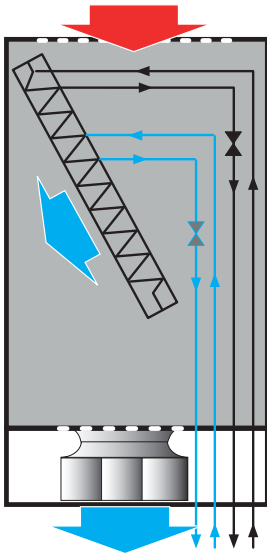

Two water circuits are connected to the same water coil. Each water circuit can operate independently from the other and can be connected to a different water supply system. The two circuits can operate one at time or together.

5.3.2 Water coil types

The water coil can have the following configurations:

- Legacy coil
- Smart coil
- Eco coil
- Dual source coil

Rated performances are stated in *PCW Product document* for the working points specified in the following table:

Coil type	ESP (*) [Pa]	Return Air temperature [°C]	RH [%]	Inlet Water temperature [°C]	Outlet Water temperature [°C]
Legacy coil	20	26	40	10	15
Smart coil	20	35	30	18	26
Eco coil	20	30	30	8	15
Dual source coil	20	24	50	7	12

(*) External Static Pressure - **NOTE:** For performance in specific working point, please use selection software.

5.3.3 Water valve types

The water valve can be of the following types:

2-way ball valve

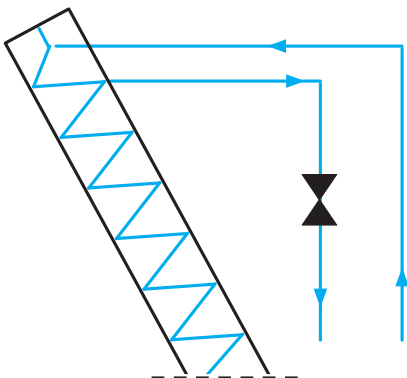

Modulation of the water outlet opening
Operated by 0-10 V signal

3-way ball valve

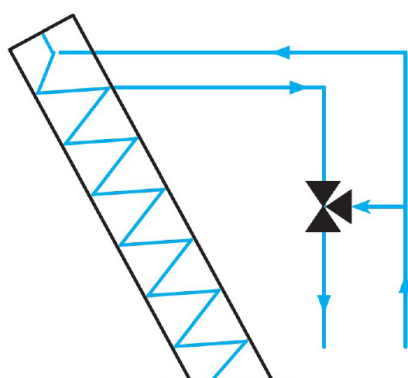

Modulation of the water outlet opening + water flow back into the coil
Operated by 0-10 V signal

Pressure independent control valve (PICV)

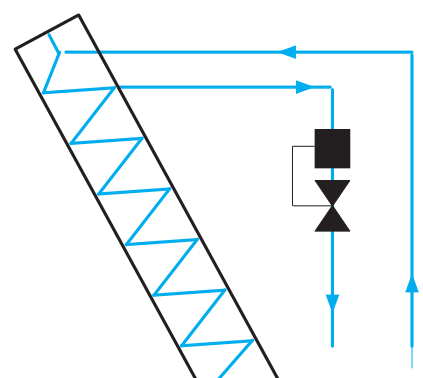

An ultrasonic flow sensor measures the flow rate at water outlet and adjusts the valve opening
Operated by Modbus

Max. flow volume for PIC vavles	
	[l/s]
PW025	1,67
PW030	1,67
PW035	2,78
PW040	2,78
PW046	2,78
PW045	6,3
PW060	6,3
PW066	6,3
PW070	6,3
PW080	6,3
PW091	6,3
PW095	12,6
PW110	12,6
PW136	12,6
PW145	12,6
PW161	12,6
PW170	12,6
PW201	12,6



NOTICE

Do not exceed the nominal operating pressure of the circuit components.

Air Bubbles on the circuit can cause a loss of precision in cooling action so de-aeration is recommended

Valve comparison	Glycol mixture	PN	Fluid Temperature limit
2-way	Up to 50%	16	-10...120°C
3-way	Up to 50%	16	-10...120°C
PICV	Up to 50%	25	-10...120°C

All valves are internally threaded.
To get precise pressure drop data, please use selection software.

5.3.4 Drain valves

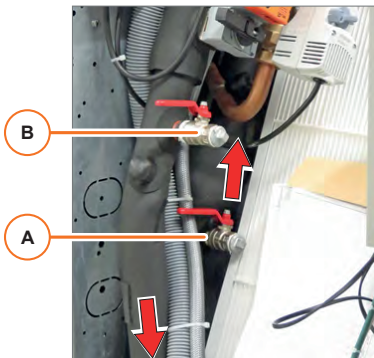

The unit is provided with the following drain valves:

- A Drain valve on water inlet piping
- B Drain valve on water outlet piping

5.3.5 Hot water coil (optional)

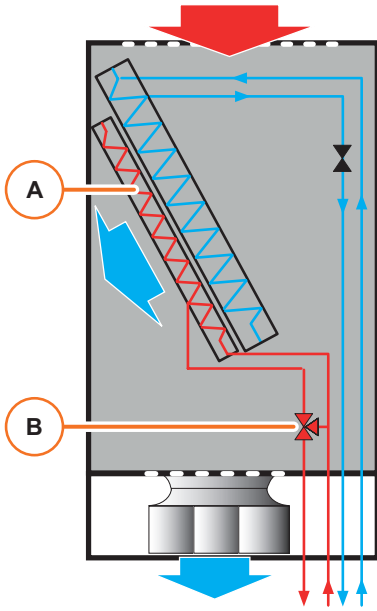

The **hot water** flows through the hot water coil [A], thus heating the air for humidity control.

The coil is made of copper pipes and aluminium fins.

Valve is equipped with 3-way [B] and vent valve.

Maximal operating pressure is 8 bar

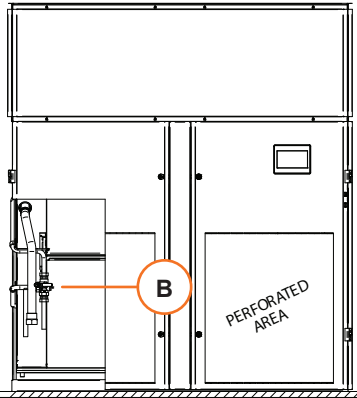

A three-way ON-OFF valve [C] directly driven by the microprocessor controller is supplied as standard.

If hot water reheat option is selected, humidity sensor for dehumidification system is installed in the unit as standard.

The customer must provide the following sensors:

- hot water thermostat, to check that hot water temperature is correct.

(Vertiv™ can provide the sensors on request)

5.3.6 Chilled water connection configurations

The connections of the chilled water may be arranged as following:

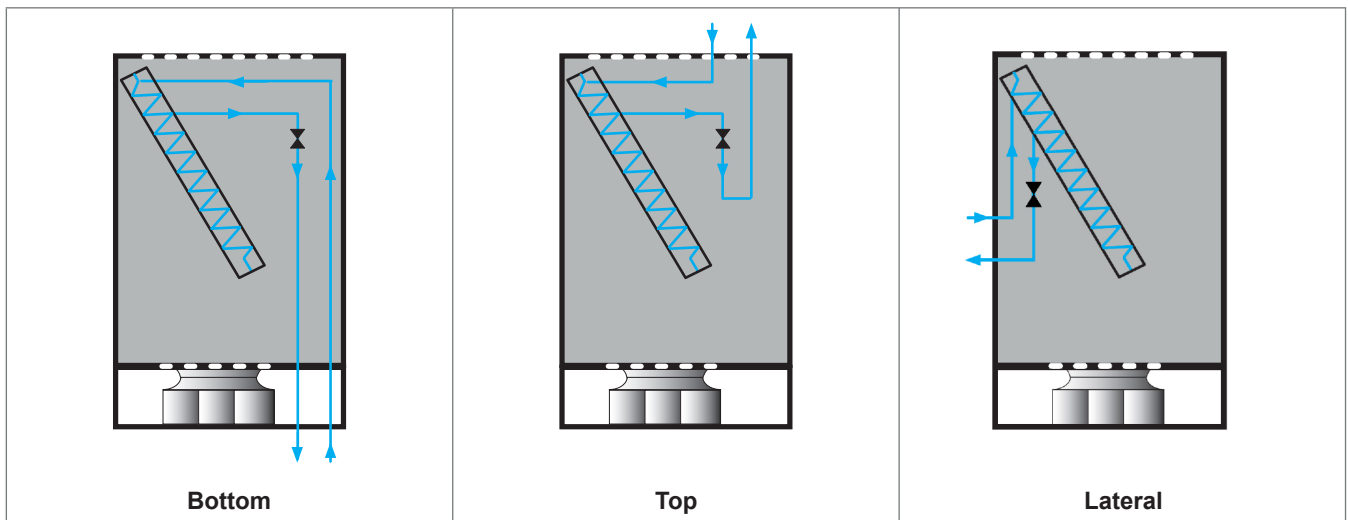

5.4 Air System

5.4.1 Fans

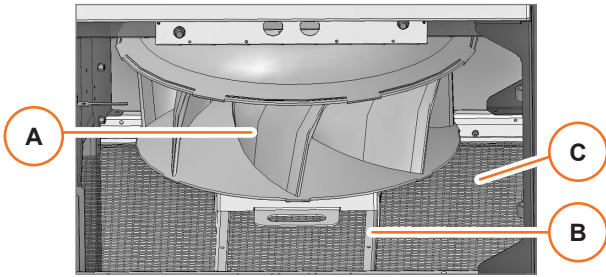

- A** Fan

- B** Fan supporting frame

- C** Protective grid
The grids protect against contact from the top (for the **Upflow versions**) or from below the floor, if the floor is opened for any reason near the machine (for the **Downflow versions**).

- The fan motors are protected by thermal magnetic circuit breaker.
See *5.5 Electric and Control System* for details.

5.4.2 Filters

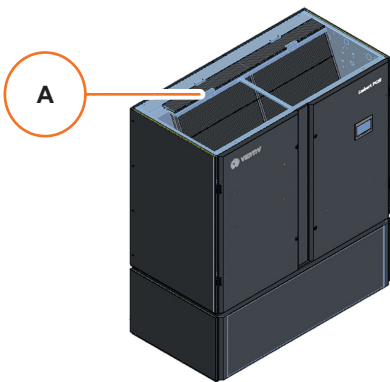

- A** **Filter**
The figure shows standard filters. Other type of filters are available as options.
See *Annex F - Accessories* for details

- **Filter clog sensor**
A sensor sends an alarm to the control system if the pressure difference through the filter is higher than a threshold value - the filter is clogged. Measured by filter differential pressure switch.
Differential pressure transducer
A sensor sends an value of air pressure drop to the control system if the pressure difference through the filter is higher than a threshold value - the filter is clogged.

5.4.3 Heating (optional)

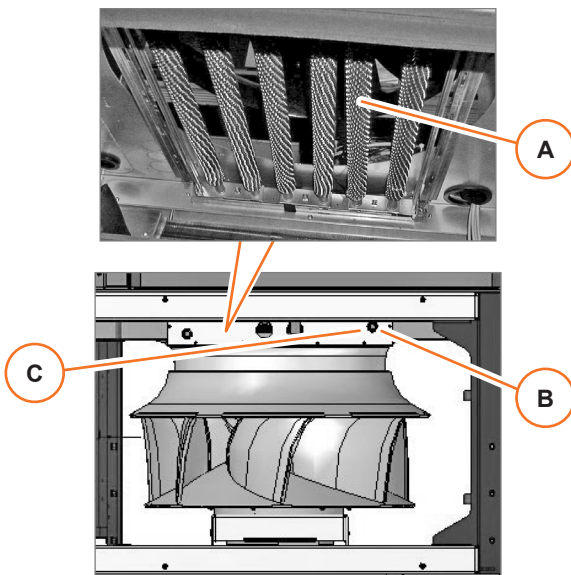

- A** **Heater**



- B** **Heater safety thermostat**
Function
The safety thermostat is installed on the heater.
It switches OFF the heater if its temperature is higher than the alarm value.

- C** **Reset button**
Function
In case of activation of the safety thermostat, a manual reset is required.
 - Press the button [C] to do the manual reset of the heater.
 - Reset the temperature alarm on the control panel.

- **Safety air high temperature sensor**
This sensor measures the air temperature at the unit outlet and switches off the heater if the air temperature is higher than the alarm threshold.

5.4.4 Humidifier (optional)

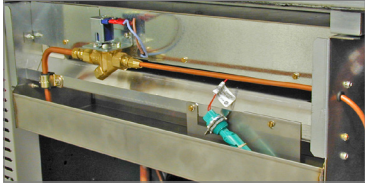
The humidifier can be of the following types:

Electrode	Infrared	Ultrasonic
 <p data-bbox="129 719 427 745">Installed inside the machine</p> <p data-bbox="129 831 515 857">See Annex G - Electrode Humidifier</p>	 <p data-bbox="584 719 882 745">Installed inside the machine</p> <p data-bbox="584 831 951 857">See Annex H - Infrared Humidifier</p>	 <p data-bbox="1042 719 1469 775">Independent module installed under the machine</p> <p data-bbox="1042 786 1442 813">Only for Downflow Up configurations</p> <p data-bbox="1042 831 1422 857">See Annex I - Ultrasonic Humidifier</p>

5.4.5 Condensate tray

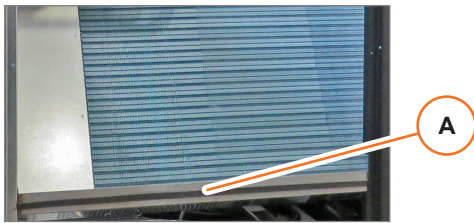

The tray [A] collects the condensate from heat exchanger.

5.4.6 Condensate pump (optional)

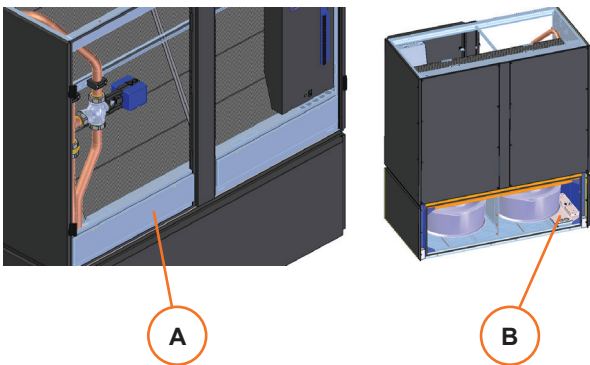

An optional condensate pump is available to deliver the condensate to a higher level. The pump discharges both condensate water from exchange coil and drain water from humidifier (if installed).

- A Condensate Tray
- B Condensate Pump

5.4.7 Sensors and instruments

- Humidity and temperature sensor for the air returning from the room into the unit
- Temperature sensor (NTC type) for the air at the unit outlet.

This sensor is normally fixed on the fan grid, but it can be moved in a remote position since its cable is more than 1 m long.

NOTE Other optional remote temperature sensors may be connected to the unit by the end user. Only Modbus type are allowed.

See 5.6 Modbus Connections for details.

5.5 Electric and Control System

5.5.1 Standard or dual power supply

The unit may be delivered with standard power supply or optional dual power supply in order to have the units up and running if the main power supply fails.

The following table explains the main options.

Make reference to the *Electric Diagrams* for details about your unit power supply system.

See 6. *Technical Data* for the power supply relevant data and limits (voltage, frequency, ...).

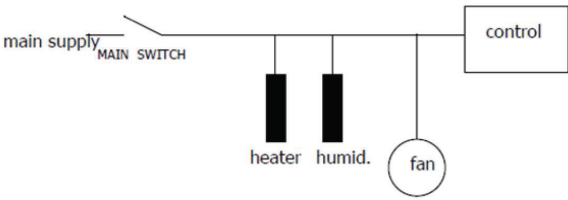
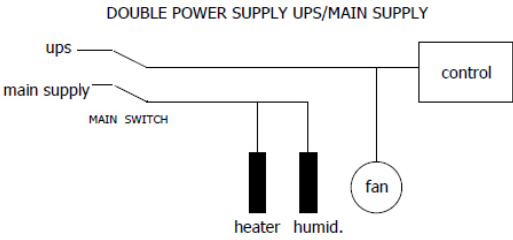
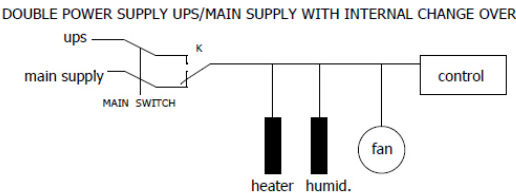
Option	Description	What happens in case of power failure	What happens when power is restored
Standard power supply	Single supply line 	The unit is fed by main line, in case of power failure unit switch OFF.	Once power is restored the unit waits control reboots (roughly 60 seconds) and after start again to operate.
Dual power supply parallel	Double power supply to the same disconnecting switch 	The unit is fed by two separate power supplies, main line and UPS/Genset. In case of power failure only UPS/Genset is available and unit grant cooling.	Once main power restored heating and humidification are available and they can be enable.
Dual power supply alternate	Double power supply to the ATS electric panel, which is connected to the main electric panel Each power supply can supply completely the unit. 	The unit is fed by two separate power supplies: each power supply can completely feed the unit. In case of main line failure ATS switches to the second power supply. This allows to have a complete power supply redundancy and therefore to have full cooling redundancy. Switch time at nominal current excluding loss of supply sensing time and excluding any delay timers applicable is at least 1.2 s -1.5 s.	Once main power restored ATS switch back to the main line.

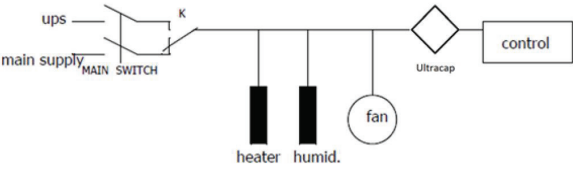
Option	Description	What happens in case of power failure	What happens when power is restored
<p>Dual power supply alternate with Ultracap for control</p> 	<p>Double power supply to the ATS electric panel, which is connected to the main electric panel. Each power supply can supply completely the unit. Control board is powered through an ultracap.</p>	<p>Unit is fitted with Dual Power. Supply Alternate Version.</p> <p>The unit is fed by two separate power supplies: each power supply can completely feed the unit. In case of main line failure ATS switches to the second power supply. This allows to have a complete power supply redundancy and therefore to have full cooling redundancy during emergency mode.</p> <p>Switching time at nominal current excluding loss of supply sensing time and excluding any delay timers applicable is at least 1,2-1,5 s.</p> <p>The ultracapacitor when completely charged, is capable of maintaining alive the CPU, the BMS card and the passive sensors for at least 1 minute (only the optional small semi-graphic display can be kept active by the ultracapacitor), full charging time for the ultracapacitor is 5 minutes.</p> <p>The remote sensors are frozen during the power OFF.</p>	<p>One power is restored the unit waits control reboots (roughly 60 seconds) and after start again to operate.</p>

ATS Positioning Monitoring – Option

Unit can display and share with BMS system (if monitoring card is present) which line is powering the unit, and thus also the position of the Automatic Transfer Switch.

5.5.2 EMC Emission

The unit satisfies the requirements for EMC regarding electro-magnetic emission IEC61000-6-2.

Industrial

The unit satisfies the requirements of IEC61000-6-2.

This choice aims to comply with requirements of compatibility of light industrial environments as regards the emission of disturbances, resisting to external disturbances without having any functionality compromised. In terms of the norm references for emissions: the conducted voltage disturbance must be lower than 73 dBuV and radiated voltage disturbance lower than 50 dBuV (@ 3 m).

Residential (optional)

The unit satisfies the requirements of IEC61000-6-2.

This is the preferred choice when the unit operates in an environment where also residential or small office devices are connected to the same power supply, and these are more sensitive to disturbance emitted by other devices, so a higher severity is needed when the unit emissions are measured.

In terms of the norm references for emissions: the conducted voltage disturbance must be lower than 66 dBuV and radiated voltage disturbance lower than 40 dBuV (@ 3 m).

5.5.3 Main components

Power side (high voltage)

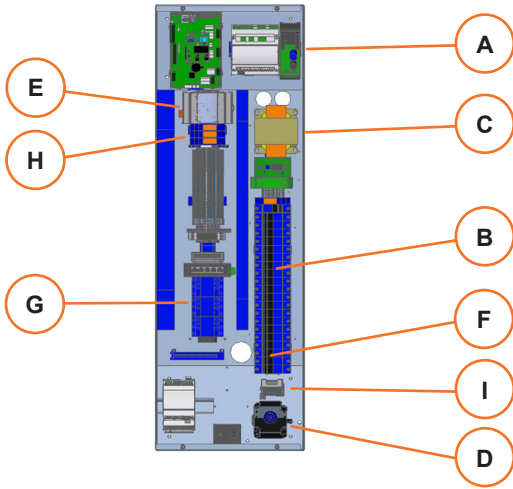

- A Power supply for touch screen
- B Thermal magnetic circuit breakers
- C Transformer
- D Clogged filter sensor
- E Ultracap
- F Disconnecting switch
- G Contactors
- H Relays
- I Amperometric transformer for humidifier

Control side (low voltage)

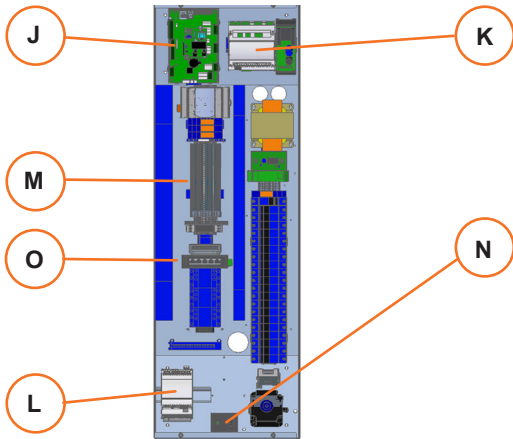

- J Control board
- K Humidifier control board
- L Expansion module
- M Terminal board
- N ON/OFF switch with LED indicator



WARNING
This is not a disconnecting switch.
See 5.5.4 Disconnecting switches

- O HUB/Ethernet switch



NOTE The electric panel is designed and manufactured according to EN 60204-1
It is recommended to use 90 degrees LAN connector for HUB/Ethernet switch.

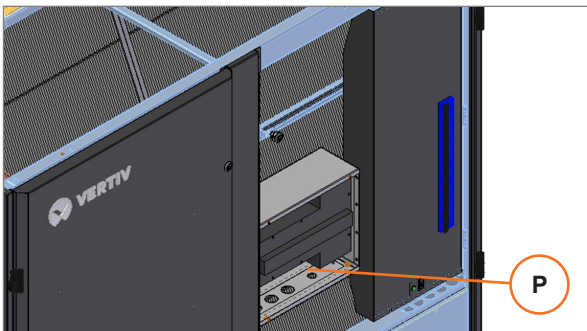

- P ATS (Automatic Transfer Switch) electric panel (optional)

5.5.4 Disconnecting switches



WARNING

Due to the presence of Ultracaps for the control and other devices, the electric and control panels can retain a stored high-voltage electrical charge for a certain time.

Before removing the panels and working inside the electric and control panels proceed as follows:

- Open all the local and remote disconnecting switches of the unit.
- Wait at least **5** minutes.
- Verify with a voltmeter that the power is **OFF**.

Access to the disconnecting switches

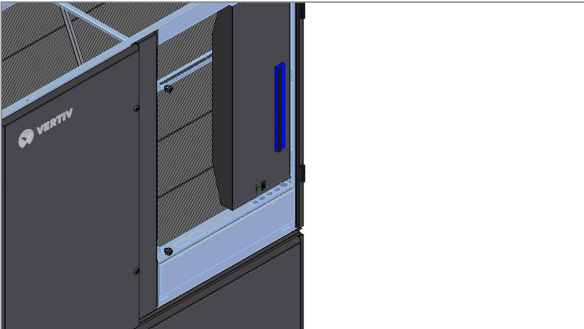

To have access to the disconnecting switches you need to unscrew the door and open it.

Single power supply

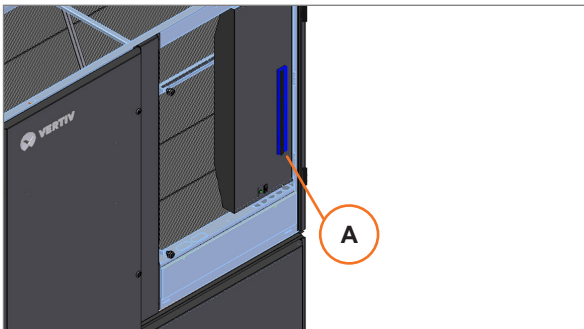

- A** Disconnecting switch
This is a disconnecting switch and it cuts OFF the electric power supply to the whole unit.

Dual alternate power supply

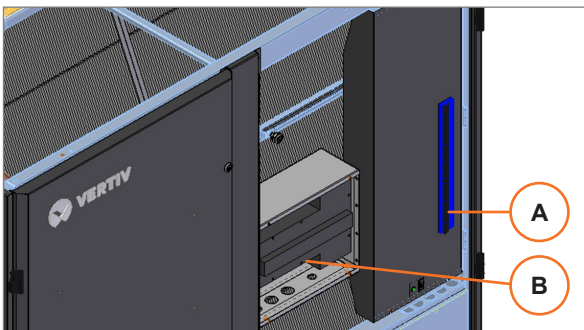

- A** Standard disconnecting switch
B ATS disconnecting switch



WARNING

The power supply is connected to the ATS disconnecting switch **[B]**.

You must open the ATS disconnecting switch to cut-OFF the power supply to the unit.

5.5.5 Control panel

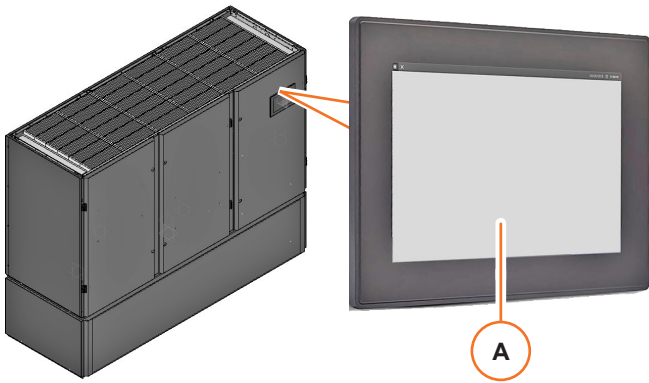

- A** Control panel
The unit is usually controlled remotely by a network connection.
The unit may also have control panel (optional) in the front door.
See the *PDX-PCW Control Application User Manual* for details.

5.5.6 Ethernet connection

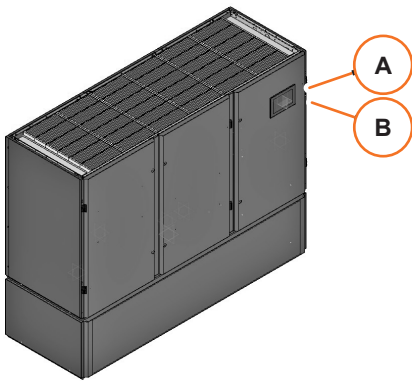

- A** RJ11 - CANbus port for connection of an external display

- B** RJ45 - Ethernet port for connection of an external laptop

5.5.7 Protective functions

The control system manages all the safety and operating devices needed for reliable automatic operation. The main alarms are briefly explained below. make reference to the *PDX-PCW Control Application* for details.

5.5.8 Fans control

All the units have EC fans.
The unit control system adjusts the fans rotation speed depending on the operating conditions.

Protective functions	<ul style="list-style-type: none"> Electronics overheating protection Motor overheating protection Locked rotor protection Short circuit at the motor output
Fans	<p>Connection to the unit through Modbus protocol. If the Modbus connection is interrupted, then the fans continue to run at a preset speed. Speed adjustment between 0 and 100% of the maximum speed. NOTE <i>It is possible to set a limit to the maximum speed in order to reduce the noise emission.</i></p>

5.5.9 Smart Aisle™

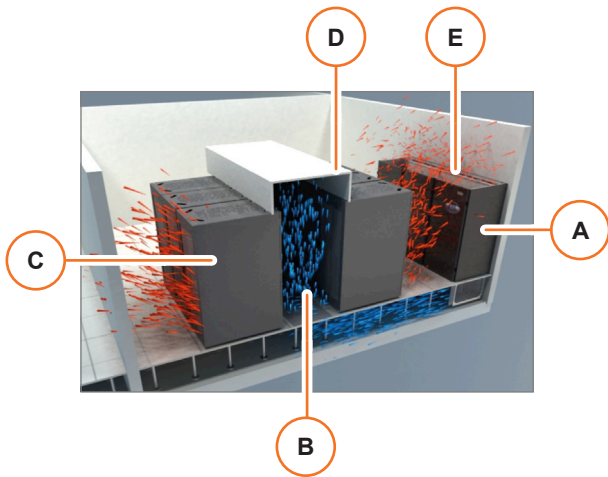

The **Liebert® PCW** units can be used in a **Smart Aisle™** system.

The Smart Aisle™ is a **Liebert®** patented system for the control of the units in a room with cold aisle arrangement.

The unit **[A]** blows the air into the cold aisle **[B]** through the raised floor.

The hot air coming from the active equipment **[C]** returns to the unit.

The unit airflow is managed by the fan speed modulation according to the readings from remote temperature sensors **[D]** installed on the border of cold/hot aisle area.

The unit can be equipped with optional motorized dampers **[E]** on the air suction. Equipped with 3-position or & 0-10V control servomotor.

5.6 Modbus Connections

5.6.1 General description

The control system can manage different devices via Modbus.

The following figures show the architecture and detail of the structure.

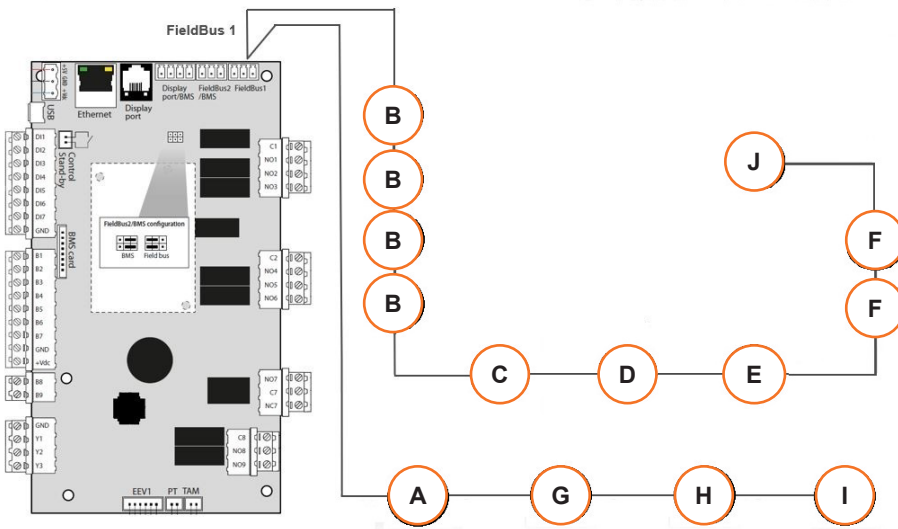

A	Return sensor T+H (up to 4)	F	Pressure Independent Control valve (up to 4)
B	EC fans (up to 6)	G	Air Economizer sensor T+H
C	Humidifier	H	Optional sensors T or T+H (up to 3)
D	Energy meter	I	Remote sensors T or T+H (up to 10)
E	Expansion board	J	Differential pressure transducer

NOTE: T - Temperature sensor
H - Humidity sensor

Settings

The internal connections and the related settings are factory made, but you may need to connect more remote devices at the installation or modify the settings of some Modbus devices.

In that case, you need to redo the settings for the Modbus connection. See *9.6 Modbus Connections and Settings*.

5.6.2 Fan management

Speed control

The fan speed can be managed in one of the following ways:

Return sensor	The fan speed is modulated from minimum value to maximum value following the return temperature deviation.
Supply sensor	The fan speed is modulated from minimum value to maximum value following the supply temperature deviation.
Remote sensor	The fan speed is modulated from minimum value to maximum value following the remote temperature deviation.
Delta (Temperature difference)	<p>The control tries to achieve a fixed temperature difference between return temperature and supply temperature.</p> <p>When the temperature difference is inside the dead band the fan speed will not change.</p> <p>When the temperature difference is outside the dead band the control will change (increasing or decreasing) the speed of the fan trying to put the temperature difference inside the dead band.</p> <ul style="list-style-type: none"> - If the temperature difference Return - Supply is lower than the difference setpoint, then the fan will decrease the speed. - If the temperature difference Return - Supply is higher than the difference setpoint, then the fan will increase the speed.
Static pressure	<p>The speed of the fans are modulated in order to keep fixed the static pressure in the raised floor.</p> <p>When the pressure is inside the dead band the fan speed does not change; when the pressure is outside the dead band the control increases or decreases the speed of the fan trying to put the pressure inside the dead band.</p>
Return CW priority	<p>The CW valve modulates from 0% and 50% of the call for cooling based on return temperature.</p> <p>The Fan speed modulates from 50% and 100% of the call for cooling based on return temperature.</p> <p>This means the fan starts to modulate only when the CW valve is fully open.</p>
Fixed speed	During normal operation the fan will operate at the fixed speed set.

Fan speed override

The fan speed can be limited or overwritten in the following cases:

High temperature alarm	The fan will run at defined speed. This feature can be enabled or disabled.
No power	The fan will run at defined speed.
Modbus high speed operation	If enabled in case of single fan failure or single fan communication failure (or up to N-1), the remaining fans will be forced to maximum speed.
Fan and cooling forcing by user (cool/fan 100%)	The fan will run at 100%.
Heating ON Humidification ON Dehumidification ON	The fan will run at defined speed. If a higher call for fans speed occurs, the fan will operate at the higher call.
Control sensor failure	<p>Teamwork Mode:</p> <ul style="list-style-type: none"> • Return, Return CW priority, Remote or Static Pressure Control: the fan will work using the system value. • Supply or Delta: the fan will run at defined speed. If a higher call for fan speed occurs, the fan will operate at the higher call. <p>No Teamwork Mode:</p> <ul style="list-style-type: none"> • The fan will run at defined speed. If a higher call for fan speed occurs, the fan will operate at the higher call.

6. Technical Data

Content of this chapter

6.1 Structure.....	29	6.4.2 Fans.....	42
6.2 Water System.....	30	6.4.3 Electrical heaters.....	42
6.2.1 Coil configuration.....	30	6.4.4 Electrode humidifier.....	43
6.2.2 Water valves differential pressure.....	30	6.4.5 Infrared humidifier.....	44
6.2.3 Glicol mixture correction factors.....	30	6.4.6 Condensate pump.....	44
6.3 Air System.....	31	6.5 Noise Level.....	45
6.4 Electrical System.....	32		
6.4.1 Unit electrical data.....	32		

6.1 Structure

Table 03 - Frames and air distribution

Unit model	Frame type	Number of bays	U Upflow	H Downflow Frontal	D Downflow Up	E Downflow Down	Extended
PW025	1	1	YES	YES	YES	---	---
PW030	1	1	YES	YES	YES	---	---
PW035	2	1.5	YES	YES	YES	YES	---
PW040	2	1.5	YES	YES	YES	YES	---
PW046	2	1.5	YES	---	YES	YES	YES
PW045	3	2	YES	YES	YES	YES	---
PW060	3	2	YES	YES	YES	YES	---
PW066	3	2	YES	---	YES	YES	YES
PW070	4	2	YES	YES	YES	YES	---
PW080	4	2	YES	YES	YES	YES	---
PW091	4	2	YES	---	YES	YES	YES
PW095	5	3	YES	YES	YES	YES	---
PW110	5	3	YES	YES	YES	YES	---
PW136	5	3	---	YES	YES	YES	YES
PW145	6	3	---	---	YES	YES	---
PW161	6	3	---	---	YES	YES	YES
PW170	7	4	---	---	YES	YES	---
PW201	7	4	---	---	YES	YES	YES

6.2 Water System

6.2.1 Coil configuration

Table 04 - Coil configuration

Unit model	Legacy Coil	Smart Coil	Eco Coil	Dual Source Coil
PW025	YES	----	YES	----
PW030	YES	YES	----	----
PW035	YES	----	YES	----
PW040	YES	YES	----	YES
PW046	YES	YES	----	YES
PW045	YES	----	YES	----
PW060	YES	YES	YES	YES
PW066	YES	YES	----	YES
PW070	YES	----	YES	----
PW080	YES	YES	----	YES
PW091	YES	YES	----	YES
PW095	YES	----	YES	----
PW110	YES	YES	----	YES
PW136	YES	YES	----	YES
PW145	YES	YES	----	YES
PW161	YES	YES	----	YES
PW170	YES	YES	----	YES
PW201	YES	YES	----	YES

6.2.2 Water valves differential pressure

Table 05 - water valves differential pressure

	2-WAY & 3-WAY VALVE		PICVs	
	Max differential pressure [kPa]	Close-OFF pressure [kPa]	Max differential pressure [kPa]	Close-OFF pressure [kPa]
For all models	350	1400	350	1400

6.2.3 Glycol mixture correction factors

The water glycol mixtures are used as medium for heat transfer where chiller is placed outside the building and outdoor temperature is below the freezing point of water. The use of low freezing point mixtures causes a modification in the main thermodynamic properties of the units. The main parameters affected by the use of glycol mixtures are the following:

- Cooling capacity
- Mixture volumetric flow
- Pressure drop

The correction factors referred to the most common ethylene glycol mixtures are reported in the following table:

Table 06 - Cooling system - Glycol mixture correction factors

Parameter	Correcting factor	Ethylene glycol [% in weight]					
		0	10	20	30	40	50
Freezing temperature [°C]	---	0	-4,4	-9,9	-16,6	-25,2	-37,2
Cooling capacity	F3	1	0,987	0,977	0,969	0,958	0,950
Mixture volume flow rat	F4	1	1,046	1,080	1,098	1,150	1,210
Mixture side pressure drop	F5	1	1,053	1,109	1,168	1,234	1,311

We indicate as RO, VO, DP0 respectively the unit cooling capacity, the water volumetric flow rate and the pressure drop with 0% ethylene glycol.

When we use glycol mixtures at different percentage with the same inlet and outlet temperatures at the heat exchanger, the performance will vary as follows:

- Cooling capacity = RO x F3
- Volumetric flow rate = VO x F3 x F4
- Mixture pressure drop = DP1 x F5.

where DP1 is the unit water pressure drop for the new volumetric mixture flow rate.

6.3 Air System

Table 07 - Air system - Fans number and weight

Model	Number of fans	EC fan advance - HE	EC fan advance - HP
PW025	1	24.0	21.2
PW030	1	24.0	21.2
PW035	1	21.2	27.9
PW040	1	21.2	27.9
PW046	1	21.2	27.9
PW045	1	21.2	27.9
PW060	2	21.2	27.9
PW066	2	21.2	27.9
PW070	2	21.2	27.9
PW080	2	21.2	27.9
PW091	2	21.2	27.9
PW095	3	21.2	27.9
PW110	3	21.2	27.9
PW136	3	21.2	27.9
PW145	3	21.2	27.9
PW161	3	21.2	27.9
PW170	4	21.2	27.9
PW201	4	21.2	27.9

NOTE Values given for each single fan. The model is the same both for 50 Hz and 60 Hz.

6.4 Electrical System

6.4.1 Unit electrical data

General remarks

- The cables have to be sized in compliance with local standards and according to the type and characteristics (for example Amps) of installation.
- The recommended wires size have been determined considering the maximum electrical heaters capacity selectable and the maximum humidifier capacity selectable.
- The data in the tables do not consider the absorbed current from the condensate pump and for other options not explicitly described.
- The specific energy allowed to flow from the circuit breakers, installed by the user, must be lower than 300.000 A²s.
- Prescriptions on the differential relay required to the user:
 - For special places (healthcare facilities, etc...) comply with the local regulations.
 - For ordinary places, a low sensitivity is suggested (300 mA) coordinated with the value of the ground heater (IEC 364): Ra 50/1a (Art.413.1.4.1, CEI 648 or IEC 60364445).
 - In case of frequent over-voltages with mains impulse, it is advisable to install a selective differential and to evaluate the need for adopting other devices.
 - The FLA is for units without the options of condensate pump and condensing unit.
 - The FLA is for units with AUTOMATIC FUNCTIONS only: in manual mode operation the FLA must be lower than the maximum current of the main switch.

The Modbus wiring is field-supplied and must be:

- shielded
- 24-18 AWG (0.20-0.82 mm²) stranded tinned copper until 100 m, 18 AWG (0.82 mm²) stranded tinned copper until 130 m
- twisted pair (minimum 8 twists per foot)
- low capacitance (17pF/ft or less)
- plenum rated (NEC type CMP) if required by local codes
- UV and moisture resistant or run within conduit once in an outdoor environment, and must be temperature and voltage rated for conditions present.

Examples: Belden part number 89207(plenum rated) or Alpha Wire part number 6454 (UV resistant outdoor rated) category 5, 5e or higher.



CAUTIONS Do not run the Modbus cable in the same conduit, raceway or chase used for high-voltage wiring. Mandatory shield connection to ground close Master (unit control board). For Modbus network lengths greater than 130 m, contact Vertiv™ for assistance.

Units with power supply 400 V / 3ph + N / 50 Hz + Earth

Table 08 - Electrical data for cooling only - 400 V / 3ph + N / 50 Hz + Earth

Units	EC fan advance - HE			EC fan advance - HP			WITHOUT ATS		WITH ATS	
	FLA [A]	LRA [A]	Recommended circuit breaker size breaker C curve, RCD I _{dn} =0,3A type B or B++ (A)	FLA [A]	LRA [A]	Recommended circuit breaker size breaker C curve, RCD I _{dn} =0,3A type B or B++ (A)	"Recommended wires size [mm ²] (2)"	"min./max. Cu cable size [mm ²]"	"Recommended wires size [mm ²] (2)"	"min./max. Cu cable size [mm ²]"
PW025	4.00	4.00	16.0	5.10	5.10	16.0	5G2.5mm ²	0.75.....35mm ²	5G10mm ²	10.....70mm ²
PW030	4.00	4.00	16.0	5.10	5.10	16.0	5G2.5mm ²	0.75.....35mm ²	5G10mm ²	10.....70mm ²
PW035	5.10	5.10	16.0	5.32	5.32	16.0	5G2.5mm ²	0.75.....35mm ²	5G10mm ²	10.....70mm ²
PW040	5.10	5.10	16.0	5.32	5.32	16.0	5G2.5mm ²	0.75.....35mm ²	5G10mm ²	10.....70mm ²
PW046	5.10	5.10	16.0	5.32	5.32	16.0	5G2.5mm ²	0.75.....35mm ²	5G10mm ²	10.....70mm ²
PW045	5.10	5.10	16.0	5.32	5.32	16.0	5G2.5mm ²	0.75.....35mm ²	5G10mm ²	10.....70mm ²
PW060	10.20	10.20	32.0	10.64	10.64	32.0	5G6mm ²	0.75.....35mm ²	5G10mm ²	10.....70mm ²
PW066	10.20	10.20	32.0	10.64	10.64	32.0	5G6mm ²	0.75.....35mm ²	5G10mm ²	10.....70mm ²
PW070	10.20	10.20	32.0	10.64	10.64	32.0	5G6mm ²	0.75.....35mm ²	5G10mm ²	10.....70mm ²
PW080	10.20	10.20	32.0	10.64	10.64	32.0	5G6mm ²	0.75.....35mm ²	5G10mm ²	10.....70mm ²
PW091	10.20	10.20	32.0	10.64	10.64	32.0	5G6mm ²	0.75.....35mm ²	5G10mm ²	10.....70mm ²
PW095	15.30	15.30	32.0	15.96	15.96	32.0	5G6mm ²	0.75.....35mm ²	5G10mm ²	10.....70mm ²
PW110	15.30	15.30	32.0	15.96	15.96	32.0	5G6mm ²	0.75.....35mm ²	5G10mm ²	10.....70mm ²
PW136	15.30	15.30	32.0	15.96	15.96	32.0	5G6mm ²	0.75.....35mm ²	5G10mm ²	10.....70mm ²
PW145	15.30	15.30	32.0	15.96	15.96	32.0	5G6mm ²	0.75.....35mm ²	5G10mm ²	10.....70mm ²
PW161	15.30	15.30	32.0	15.96	15.96	32.0	5G6mm ²	0.75.....35mm ²	5G10mm ²	10.....70mm ²
PW170	20.40	20.40	32.0	21.28	21.28	32.0	5G6mm ²	0.75.....35mm ²	5G10mm ²	10.....70mm ²
PW201	20.40	20.40	32.0	21.28	21.28	32.0	5G6mm ²	0.75.....35mm ²	5G10mm ²	10.....70mm ²

Note:

- Max Electrical Heaters capacity selectable;
- Max Humidifier capacity selectable;
- When connecting the power inputs cable make sure to always use ferrules on cables when they are the smallest accepted size, or when cable is "braided";
- When connecting the power inputs cable make sure to always apply recommended max torque.

Table 09 - Electrical data for cooling + heating - 400 V / 3ph + N / 50 Hz + Earth

Units	EC fan advance - HE			EC fan advance - HP			WITHOUT ATS		WITH ATS	
	FLA [A]	LRA [A]	Recommended circuit breaker size breaker C curve, RCD I _{dn} =0,3A type B or B++ (A)	FLA [A]	LRA [A]	Recommended circuit breaker size breaker C curve, RCD I _{dn} =0,3A type B or B++ (A)	"Recommended wires size [mm ²] (2)"	"min./max. Cu cable size [mm ²]"	"Recommended wires size [mm ²] (2)"	"min./max. Cu cable size [mm ²]"
PW025	14.80	14.80	20.0	15.90	15.90	20.0	5G2,5mm ²	0.75.....35mm ²	5G10mm ²	10.....70mm ²
PW030	14.80	14.80	20.0	15.90	15.90	20.0	5G2,5mm ²	0.75.....35mm ²	5G10mm ²	10.....70mm ²
PW035	15.90	15.90	20.0	16.12	16.12	20.0	5G2,5mm ²	0.75.....35mm ²	5G10mm ²	10.....70mm ²
PW040	15.90	15.90	20.0	16.12	16.12	20.0	5G2,5mm ²	0.75.....35mm ²	5G10mm ²	10.....70mm ²
PW046	15.90	15.90	20.0	16.12	16.12	20.0	5G2,5mm ²	0.75.....35mm ²	5G10mm ²	10.....70mm ²
PW045	15.90	15.90	20.0	16.12	16.12	20.0	5G2,5mm ²	0.75.....35mm ²	5G10mm ²	10.....70mm ²
PW060	31.80	31.80	40.0	32.24	32.24	40.0	5G10mm ²	0.75.....35mm ²	5G10mm ²	10.....70mm ²
PW066	31.80	31.80	40.0	32.24	32.24	40.0	5G10mm ²	0.75.....35mm ²	5G10mm ²	10.....70mm ²
PW070	31.80	31.80	40.0	32.24	32.24	40.0	5G10mm ²	0.75.....35mm ²	5G10mm ²	10.....70mm ²
PW080	31.80	31.80	40.0	32.24	32.24	40.0	5G10mm ²	0.75.....35mm ²	5G10mm ²	10.....70mm ²
PW091	31.80	31.80	40.0	32.24	32.24	40.0	5G10mm ²	0.75.....35mm ²	5G10mm ²	10.....70mm ²
PW095	47.70	47.70	63.0	48.36	48.36	63.0	5G16mm ²	0.75.....35mm ²	5G16mm ²	10.....70mm ²
PW110	47.70	47.70	63.0	48.36	48.36	63.0	5G16mm ²	0.75.....35mm ²	5G16mm ²	10.....70mm ²
PW136	47.70	47.70	63.0	48.36	48.36	63.0	5G16mm ²	0.75.....35mm ²	5G16mm ²	10.....70mm ²
PW145	47.70	47.70	63.0	48.36	48.36	63.0	5G16mm ²	0.75.....35mm ²	5G16mm ²	10.....70mm ²
PW161	47.70	47.70	63.0	48.36	48.36	63.0	5G16mm ²	0.75.....35mm ²	5G16mm ²	10.....70mm ²
PW170	52.80	52.80	63.0	53.68	53.68	63.0	5G16mm ²	0.75.....35mm ²	5G16mm ²	10.....70mm ²
PW201	52.80	52.80	63.0	53.68	53.68	63.0	5G16mm ²	0.75.....35mm ²	5G16mm ²	10.....70mm ²

Note:

- Max Electrical Heaters capacity selectable;
- Max Humidifier capacity selectable;
- When connecting the power inputs cable make sure to always use ferrules on cables when they are the smallest accepted size, or when cable is "braided";
- When connecting the power inputs cable make sure to always apply recommended max torque.

Table 10 - Electrical data for cooling + humidification - 400 V / 3ph + N / 50 Hz + Earth

Units	EC fan advance - HE			EC fan advance - HP			WITHOUT ATS		WITH ATS	
	FLA [A]	LRA [A]	Recommended circuit breaker size breaker C curve, RCD I _{dn} =0,3A type B or B++ (A)	FLA [A]	LRA [A]	Recommended circuit breaker size breaker C curve, RCD I _{dn} =0,3A type B or B++ (A)	"Recommended wires size [mm ²] (2)"	"min./max. Cu cable size [mm ²]"	"Recommended wires size [mm ²] (2)"	"min./max. Cu cable size [mm ²]"
PW025	12.70	12.70	20.0	13.80	13.80	20.0	5G2,5mm ²	0.75.....35mm ²	5G10mm ²	10.....70mm ²
PW030	12.70	12.70	20.0	13.80	13.80	20.0	5G2,5mm ²	0.75.....35mm ²	5G10mm ²	10.....70mm ²
PW035	13.80	13.80	20.0	14.02	14.02	20.0	5G2,5mm ²	0.75.....35mm ²	5G10mm ²	10.....70mm ²
PW040	13.80	13.80	20.0	14.02	14.02	20.0	5G2,5mm ²	0.75.....35mm ²	5G10mm ²	10.....70mm ²
PW046	13.80	13.80	20.0	14.02	14.02	20.0	5G2,5mm ²	0.75.....35mm ²	5G10mm ²	10.....70mm ²
PW045	19.00	19.00	25.0	19.22	19.22	25.0	5G4mm ²	0.75.....35mm ²	5G10mm ²	10.....70mm ²
PW060	24.10	24.10	32.0	24.54	24.54	32.0	5G6mm ²	0.75.....35mm ²	5G10mm ²	10.....70mm ²
PW066	24.10	24.10	32.0	24.54	24.54	32.0	5G6mm ²	0.75.....35mm ²	5G10mm ²	10.....70mm ²
PW070	24.10	24.10	32.0	24.54	24.54	32.0	5G6mm ²	0.75.....35mm ²	5G10mm ²	10.....70mm ²
PW080	24.10	24.10	32.0	24.54	24.54	32.0	5G6mm ²	0.75.....35mm ²	5G10mm ²	10.....70mm ²
PW091	24.10	24.10	32.0	24.54	24.54	32.0	5G6mm ²	0.75.....35mm ²	5G10mm ²	10.....70mm ²
PW095	29.20	29.20	40.0	29.86	29.86	40.0	5G10mm ²	0.75.....35mm ²	5G10mm ²	10.....70mm ²
PW110	29.20	29.20	40.0	29.86	29.86	40.0	5G10mm ²	0.75.....35mm ²	5G10mm ²	10.....70mm ²
PW136	29.20	29.20	40.0	29.86	29.86	40.0	5G10mm ²	0.75.....35mm ²	5G10mm ²	10.....70mm ²
PW145	29.20	29.20	40.0	29.86	29.86	40.0	5G10mm ²	0.75.....35mm ²	5G10mm ²	10.....70mm ²
PW161	29.20	29.20	40.0	29.86	29.86	40.0	5G10mm ²	0.75.....35mm ²	5G10mm ²	10.....70mm ²
PW170	34.30	34.30	40.0	35.18	35.18	40.0	5G10mm ²	0.75.....35mm ²	5G10mm ²	10.....70mm ²
PW201	34.30	34.30	40.0	35.18	35.18	40.0	5G10mm ²	0.75.....35mm ²	5G10mm ²	10.....70mm ²

Note:

- Max Electrical Heaters capacity selectable;
- Max Humidifier capacity selectable;
- When connecting the power inputs cable make sure to always use ferrules on cables when they are the smallest accepted size, or when cable is "braided";
- When connecting the power inputs cable make sure to always apply recommended max torque.

Units with power supply 460 V / 3ph / 60 Hz + Earth

Table 11 - Electrical data for cooling only - 460 V / 3ph / 60 Hz + Earth

Units	EC fan advance - HE			EC fan advance - HP			WITHOUT ATS		WITH ATS	
	FLA [A]	LRA [A]	Recommended circuit breaker size breaker C curve, RCD I _{dn} =0,3A type B or B++ (A)	FLA [A]	LRA [A]	Recommended circuit breaker size breaker C curve, RCD I _{dn} =0,3A type B or B++ (A)	"Recommended wires size [mm ²] (2)"	"min./max. Cu cable size [mm ²]"	"Recommended wires size [mm ²] (2)"	"min./max. Cu cable size [mm ²]"
PW025	3.47	3.47	20.0	4.10	4.10	20.0	4G2.5mm ²	1.5.....35mm ²	4G10mm ²	10.....70mm ²
PW030	3.47	3.47	20.0	4.10	4.10	20.0	4G2.5mm ²	1.5.....35mm ²	4G10mm ²	10.....70mm ²
PW035	4.10	4.10	20.0	4.62	4.62	20.0	4G2.5mm ²	1.5.....35mm ²	4G10mm ²	10.....70mm ²
PW040	4.10	4.10	20.0	4.62	4.62	20.0	4G2.5mm ²	1.5.....35mm ²	4G10mm ²	10.....70mm ²
PW046	4.10	4.10	20.0	4.62	4.62	20.0	4G2.5mm ²	1.5.....35mm ²	4G10mm ²	10.....70mm ²
PW045	4.10	4.10	20.0	4.62	4.62	20.0	4G2.5mm ²	1.5.....35mm ²	4G10mm ²	10.....70mm ²
PW060	8.20	8.20	32.0	9.24	9.24	32.0	4G6mm ²	1.5.....35mm ²	4G10mm ²	10.....70mm ²
PW066	8.20	8.20	32.0	9.24	9.24	32.0	4G6mm ²	1.5.....35mm ²	4G10mm ²	10.....70mm ²
PW070	8.20	8.20	32.0	9.24	9.24	32.0	4G6mm ²	1.5.....35mm ²	4G10mm ²	10.....70mm ²
PW080	8.20	8.20	32.0	9.24	9.24	32.0	4G6mm ²	1.5.....35mm ²	4G10mm ²	10.....70mm ²
PW091	8.20	8.20	32.0	9.24	9.24	32.0	4G6mm ²	1.5.....35mm ²	4G10mm ²	10.....70mm ²
PW095	12.30	12.30	32.0	13.86	13.86	32.0	4G6mm ²	1.5.....35mm ²	4G10mm ²	10.....70mm ²
PW110	12.30	12.30	32.0	13.86	13.86	32.0	4G6mm ²	1.5.....35mm ²	4G10mm ²	10.....70mm ²
PW136	12.30	12.30	32.0	13.86	13.86	32.0	4G6mm ²	1.5.....35mm ²	4G10mm ²	10.....70mm ²
PW145	12.30	12.30	32.0	13.86	13.86	32.0	4G6mm ²	1.5.....35mm ²	4G10mm ²	10.....70mm ²
PW161	12.30	12.30	32.0	13.86	13.86	32.0	4G6mm ²	1.5.....35mm ²	4G10mm ²	10.....70mm ²
PW170	16.40	16.40	32.0	18.48	18.48	32.0	4G6mm ²	1.5.....35mm ²	4G10mm ²	10.....70mm ²
PW201	16.40	16.40	32.0	18.48	18.48	32.0	4G6mm ²	1.5.....35mm ²	4G10mm ²	10.....70mm ²

Note:

- Max Electrical Heaters capacity selectable;
- Max Humidifier capacity selectable;
- When connecting the power inputs cable make sure to always use ferrules on cables when they are the smallest accepted size, or when cable is "braided";
- When connecting the power inputs cable make sure to always apply recommended max torque.

Table 12 - Electrical data for cooling + heating - 460 V / 3ph / 60 Hz + Earth

Units	EC fan advance - HE			EC fan advance - HP			WITHOUT ATS		WITH ATS	
	FLA [A]	LRA [A]	Recommended circuit breaker size breaker C curve, RCD I _{dn} =0,3A type B or B++ (A)	FLA [A]	LRA [A]	Recommended circuit breaker size breaker C curve, RCD I _{dn} =0,3A type B or B++ (A)	"Recommended wires size [mm ²] (2)"	"min./max. Cu cable size [mm ²]"	"Recommended wires size [mm ²] (2)"	"min./max. Cu cable size [mm ²]"
PW025	12.87	12.87	20.0	13.50	13.50	20.0	4G2.5mm ²	1.5.....35mm ²	4G10mm ²	10.....70mm ²
PW030	12.87	12.87	20.0	13.50	13.50	20.0	4G2.5mm ²	1.5.....35mm ²	4G10mm ²	10.....70mm ²
PW035	13.50	13.50	20.0	14.02	14.02	20.0	4G2.5mm ²	1.5.....35mm ²	4G10mm ²	10.....70mm ²
PW040	13.50	13.50	20.0	14.02	14.02	20.0	4G2.5mm ²	1.5.....35mm ²	4G10mm ²	10.....70mm ²
PW046	13.50	13.50	20.0	14.02	14.02	20.0	4G2.5mm ²	1.5.....35mm ²	4G10mm ²	10.....70mm ²
PW045	13.50	13.50	20.0	14.02	14.02	20.0	4G2.5mm ²	1.5.....35mm ²	4G10mm ²	10.....70mm ²
PW060	27.00	27.00	40.0	28.04	28.04	40.0	4G10mm ²	1.5.....35mm ²	4G10mm ²	10.....70mm ²
PW066	27.00	27.00	40.0	28.04	28.04	40.0	4G10mm ²	1.5.....35mm ²	4G10mm ²	10.....70mm ²
PW070	27.00	27.00	40.0	28.04	28.04	40.0	4G10mm ²	1.5.....35mm ²	4G10mm ²	10.....70mm ²
PW080	27.00	27.00	40.0	28.04	28.04	40.0	4G10mm ²	1.5.....35mm ²	4G10mm ²	10.....70mm ²
PW091	27.00	27.00	40.0	28.04	28.04	40.0	4G10mm ²	1.5.....35mm ²	4G10mm ²	10.....70mm ²
PW095	40.50	40.50	50.0	42.06	42.06	50.0	4G10mm ²	1.5.....35mm ²	4G10mm ²	10.....70mm ²
PW110	40.50	40.50	50.0	42.06	42.06	50.0	4G10mm ²	1.5.....35mm ²	4G10mm ²	10.....70mm ²
PW136	40.50	40.50	50.0	42.06	42.06	50.0	4G10mm ²	1.5.....35mm ²	4G10mm ²	10.....70mm ²
PW145	40.50	40.50	50.0	42.06	42.06	50.0	4G10mm ²	1.5.....35mm ²	4G10mm ²	10.....70mm ²
PW161	40.50	40.50	50.0	42.06	42.06	50.0	4G10mm ²	1.5.....35mm ²	4G10mm ²	10.....70mm ²
PW170	44.60	44.60	63.0	46.68	46.68	63.0	4G16mm ²	1.5.....35mm ²	4G16mm ²	10.....70mm ²
PW201	44.60	44.60	63.0	46.68	46.68	63.0	4G16mm ²	1.5.....35mm ²	4G16mm ²	10.....70mm ²

Note:

- Max Electrical Heaters capacity selectable;
- Max Humidifier capacity selectable;
- When connecting the power inputs cable make sure to always use ferrules on cables when they are the smallest accepted size, or when cable is "braided";
- When connecting the power inputs cable make sure to always apply recommended max torque.

Table 13 - Electrical data for cooling + humidification - 460 V / 3ph / 60 Hz + Earth

Units	EC fan advance - HE			EC fan advance - HP			WITHOUT ATS		WITH ATS	
	FLA [A]	LRA [A]	Recommended circuit breaker size breaker C curve, RCD I _{dn} =0,3A type B or B++ (A)	FLA [A]	LRA [A]	Recommended circuit breaker size breaker C curve, RCD I _{dn} =0,3A type B or B++ (A)	"Recommended wires size [mm ²] (2)"	"min./max. Cu cable size [mm ²]"	"Recommended wires size [mm ²] (2)"	"min./max. Cu cable size [mm ²]"
PW025	10.97	10.97	20.0	11.60	11.60	20.0	4G2.5mm ²	1.5.....35mm ²	4G10mm ²	10.....70mm ²
PW030	10.97	10.97	20.0	11.60	11.60	20.0	4G2.5mm ²	1.5.....35mm ²	4G10mm ²	10.....70mm ²
PW035	11.60	11.60	20.0	12.12	12.12	20.0	4G2.5mm ²	1.5.....35mm ²	4G10mm ²	10.....70mm ²
PW040	11.60	11.60	20.0	12.12	12.12	20.0	4G2.5mm ²	1.5.....35mm ²	4G10mm ²	10.....70mm ²
PW046	11.60	11.60	20.0	12.12	12.12	20.0	4G2.5mm ²	1.5.....35mm ²	4G10mm ²	10.....70mm ²
PW045	16.10	16.10	20.0	16.62	16.62	20.0	4G2.5mm ²	1.5.....35mm ²	4G10mm ²	10.....70mm ²
PW060	20.20	20.20	32.0	21.24	21.24	32.0	4G6mm ²	1.5.....35mm ²	4G10mm ²	10.....70mm ²
PW066	20.20	20.20	32.0	21.24	21.24	32.0	4G6mm ²	1.5.....35mm ²	4G10mm ²	10.....70mm ²
PW070	20.20	20.20	32.0	21.24	21.24	32.0	4G6mm ²	1.5.....35mm ²	4G10mm ²	10.....70mm ²
PW080	20.20	20.20	32.0	21.24	21.24	32.0	4G6mm ²	1.5.....35mm ²	4G10mm ²	10.....70mm ²
PW091	20.20	20.20	32.0	21.24	21.24	32.0	4G6mm ²	1.5.....35mm ²	4G10mm ²	10.....70mm ²
PW095	24.30	24.30	32.0	25.86	25.86	32.0	4G6mm ²	1.5.....35mm ²	4G10mm ²	10.....70mm ²
PW110	24.30	24.30	32.0	25.86	25.86	32.0	4G6mm ²	1.5.....35mm ²	4G10mm ²	10.....70mm ²
PW136	24.30	24.30	32.0	25.86	25.86	32.0	4G6mm ²	1.5.....35mm ²	4G10mm ²	10.....70mm ²
PW145	24.30	24.30	32.0	25.86	25.86	32.0	4G6mm ²	1.5.....35mm ²	4G10mm ²	10.....70mm ²
PW161	24.30	24.30	32.0	25.86	25.86	32.0	4G6mm ²	1.5.....35mm ²	4G10mm ²	10.....70mm ²
PW170	28.40	28.40	40.0	30.48	30.48	40.0	4G10mm ²	1.5.....35mm ²	4G10mm ²	10.....70mm ²
PW201	28.40	28.40	40.0	30.48	30.48	40.0	4G10mm ²	1.5.....35mm ²	4G10mm ²	10.....70mm ²

Note:

- Max Electrical Heaters capacity selectable;
- Max Humidifier capacity selectable;
- When connecting the power inputs cable make sure to always use ferrules on cables when they are the smallest accepted size, or when cable is "braided";
- When connecting the power inputs cable make sure to always apply recommended max torque.

Units with power supply 380 V / 3ph + N / 60 Hz + Earth

Table 14 - Electrical data for cooling only - 380 V / 3ph + N / 60 Hz + Earth

Units	EC fan advance - HE			EC fan advance - HP			WITHOUT ATS		WITH ATS	
	FLA [A]	LRA [A]	Recommended circuit breaker size breaker C curve, RCD I _{dn} =0,3A type B or B++ (A)	FLA [A]	LRA [A]	Recommended circuit breaker size breaker C curve, RCD I _{dn} =0,3A type B or B++ (A)	"Recommended wires size [mm ²] (2)"	"min./max. Cu cable size [mm ²]"	"Recommended wires size [mm ²] (2)"	"min./max. Cu cable size [mm ²]"
PW025	4.20	4.20	16.0	5.30	5.30	16.0	5G2.5mm ²	0.75.....35mm ²	5G10mm ²	10.....70mm ²
PW030	4.20	4.20	16.0	5.30	5.30	16.0	5G2.5mm ²	0.75.....35mm ²	5G10mm ²	10.....70mm ²
PW035	5.30	5.30	16.0	5.60	5.60	16.0	5G2.5mm ²	0.75.....35mm ²	5G10mm ²	10.....70mm ²
PW040	5.30	5.30	16.0	5.60	5.60	16.0	5G2.5mm ²	0.75.....35mm ²	5G10mm ²	10.....70mm ²
PW046	5.30	5.30	16.0	5.60	5.60	16.0	5G2.5mm ²	0.75.....35mm ²	5G10mm ²	10.....70mm ²
PW045	5.30	5.30	16.0	5.60	5.60	16.0	5G2.5mm ²	0.75.....35mm ²	5G10mm ²	10.....70mm ²
PW060	10.60	10.60	32.0	11.20	11.20	32.0	5G6mm ²	0.75.....35mm ²	5G10mm ²	10.....70mm ²
PW066	10.60	10.60	32.0	11.20	11.20	32.0	5G6mm ²	0.75.....35mm ²	5G10mm ²	10.....70mm ²
PW070	10.60	10.60	32.0	11.20	11.20	32.0	5G6mm ²	0.75.....35mm ²	5G10mm ²	10.....70mm ²
PW080	10.60	10.60	32.0	11.20	11.20	32.0	5G6mm ²	0.75.....35mm ²	5G10mm ²	10.....70mm ²
PW091	10.60	10.60	32.0	11.20	11.20	32.0	5G6mm ²	0.75.....35mm ²	5G10mm ²	10.....70mm ²
PW095	15.90	15.90	32.0	16.80	16.80	32.0	5G6mm ²	0.75.....35mm ²	5G10mm ²	10.....70mm ²
PW110	15.90	15.90	32.0	16.80	16.80	32.0	5G6mm ²	0.75.....35mm ²	5G10mm ²	10.....70mm ²
PW136	15.90	15.90	32.0	16.80	16.80	32.0	5G6mm ²	0.75.....35mm ²	5G10mm ²	10.....70mm ²
PW145	15.90	15.90	32.0	16.80	16.80	32.0	5G6mm ²	0.75.....35mm ²	5G10mm ²	10.....70mm ²
PW161	15.90	15.90	32.0	16.80	16.80	32.0	5G6mm ²	0.75.....35mm ²	5G10mm ²	10.....70mm ²
PW170	21.20	21.20	32.0	22.40	22.40	32.0	5G6mm ²	0.75.....35mm ²	5G10mm ²	10.....70mm ²
PW201	21.20	21.20	32.0	22.40	22.40	32.0	5G6mm ²	0.75.....35mm ²	5G10mm ²	10.....70mm ²

Note:

- Max Electrical Heaters capacity selectable;
- Max Humidifier capacity selectable;
- When connecting the power inputs cable make sure to always use ferrules on cables when they are the smallest accepted size, or when cable is "braided";
- When connecting the power inputs cable make sure to always apply recommended max torque.

Table 15 - Electrical data for cooling + heating - 380 V / 3ph + N / 60 Hz + Earth

Units	EC fan advance - HE			EC fan advance - HP			WITHOUT ATS		WITH ATS	
	FLA [A]	LRA [A]	Recommended circuit breaker size breaker C curve, RCD I _{dn} =0,3A type B or B++ (A)	FLA [A]	LRA [A]	Recommended circuit breaker size breaker C curve, RCD I _{dn} =0,3A type B or B++ (A)	"Recommended wires size [mm ²] (2)"	"min./max. Cu cable size [mm ²]"	"Recommended wires size [mm ²] (2)"	"min./max. Cu cable size [mm ²]"
PW025	15.60	15.60	20.0	16.70	16.70	20.0	5G2,5mm ²	0.75.....35mm ²	5G10mm ²	10.....70mm ²
PW030	15.60	15.60	20.0	16.70	16.70	20.0	5G2,5mm ²	0.75.....35mm ²	5G10mm ²	10.....70mm ²
PW035	16.70	16.70	20.0	17.00	17.00	20.0	5G2,5mm ²	0.75.....35mm ²	5G10mm ²	10.....70mm ²
PW040	16.70	16.70	20.0	17.00	17.00	20.0	5G2,5mm ²	0.75.....35mm ²	5G10mm ²	10.....70mm ²
PW046	16.70	16.70	20.0	17.00	17.00	20.0	5G2,5mm ²	0.75.....35mm ²	5G10mm ²	10.....70mm ²
PW045	16.70	16.70	20.0	17.00	17.00	20.0	5G2,5mm ²	0.75.....35mm ²	5G10mm ²	10.....70mm ²
PW060	33.40	33.40	40.0	34.00	34.00	40.0	5G10mm ²	0.75.....35mm ²	5G10mm ²	10.....70mm ²
PW066	33.40	33.40	40.0	34.00	34.00	40.0	5G10mm ²	0.75.....35mm ²	5G10mm ²	10.....70mm ²
PW070	33.40	33.40	40.0	34.00	34.00	40.0	5G10mm ²	0.75.....35mm ²	5G10mm ²	10.....70mm ²
PW080	33.40	33.40	40.0	34.00	34.00	40.0	5G10mm ²	0.75.....35mm ²	5G10mm ²	10.....70mm ²
PW091	33.40	33.40	40.0	34.00	34.00	40.0	5G10mm ²	0.75.....35mm ²	5G10mm ²	10.....70mm ²
PW095	50.10	50.10	63.0	51.00	51.00	63.0	5G16mm ²	0.75.....35mm ²	5G16mm ²	10.....70mm ²
PW110	50.10	50.10	63.0	51.00	51.00	63.0	5G16mm ²	0.75.....35mm ²	5G16mm ²	10.....70mm ²
PW136	50.10	50.10	63.0	51.00	51.00	63.0	5G16mm ²	0.75.....35mm ²	5G16mm ²	10.....70mm ²
PW145	50.10	50.10	63.0	51.00	51.00	63.0	5G16mm ²	0.75.....35mm ²	5G16mm ²	10.....70mm ²
PW161	50.10	50.10	63.0	51.00	51.00	63.0	5G16mm ²	0.75.....35mm ²	5G16mm ²	10.....70mm ²
PW170	55.40	55.40	63.0	56.60	56.60	63.0	5G16mm ²	0.75.....35mm ²	5G16mm ²	10.....70mm ²
PW201	55.40	55.40	63.0	56.60	56.60	63.0	5G16mm ²	0.75.....35mm ²	5G16mm ²	10.....70mm ²

Note:

- Max Electrical Heaters capacity selectable;
- Max Humidifier capacity selectable;
- When connecting the power inputs cable make sure to always use ferrules on cables when they are the smallest accepted size, or when cable is "braided";
- When connecting the power inputs cable make sure to always apply recommended max torque.

Table 16 - Electrical data for cooling + humidification - 380 V / 3ph + N / 60 Hz + Earth

Units	EC fan advance - HE			EC fan advance - HP			WITHOUT ATS		WITH ATS	
	FLA [A]	LRA [A]	Recommended circuit breaker size breaker C curve, RCD I _{dn} =0,3A type B or B++ (A)	FLA [A]	LRA [A]	Recommended circuit breaker size breaker C curve, RCD I _{dn} =0,3A type B or B++ (A)	"Recommended wires size [mm ²] (2)"	"min./max. Cu cable size [mm ²]"	"Recommended wires size [mm ²] (2)"	"min./max. Cu cable size [mm ²]"
PW025	13.30	13.30	20.0	14.40	14.40	20.0	5G2,5mm ²	0.75.....35mm ²	5G10mm ²	10.....70mm ²
PW030	13.30	13.30	20.0	14.40	14.40	20.0	5G2,5mm ²	0.75.....35mm ²	5G10mm ²	10.....70mm ²
PW035	14.40	14.40	20.0	14.70	14.70	20.0	5G2,5mm ²	0.75.....35mm ²	5G10mm ²	10.....70mm ²
PW040	14.40	14.40	20.0	14.70	14.70	20.0	5G2,5mm ²	0.75.....35mm ²	5G10mm ²	10.....70mm ²
PW046	14.40	14.40	20.0	14.70	14.70	20.0	5G2,5mm ²	0.75.....35mm ²	5G10mm ²	10.....70mm ²
PW045	19.90	19.90	25.0	20.20	20.20	25.0	5G4mm ²	0.75.....35mm ²	5G10mm ²	10.....70mm ²
PW060	25.20	25.20	32.0	25.80	25.80	32.0	5G6mm ²	0.75.....35mm ²	5G10mm ²	10.....70mm ²
PW066	25.20	25.20	32.0	25.80	25.80	32.0	5G6mm ²	0.75.....35mm ²	5G10mm ²	10.....70mm ²
PW070	25.20	25.20	32.0	25.80	25.80	32.0	5G6mm ²	0.75.....35mm ²	5G10mm ²	10.....70mm ²
PW080	25.20	25.20	32.0	25.80	25.80	32.0	5G6mm ²	0.75.....35mm ²	5G10mm ²	10.....70mm ²
PW091	25.20	25.20	32.0	25.80	25.80	32.0	5G6mm ²	0.75.....35mm ²	5G10mm ²	10.....70mm ²
PW095	30.50	30.50	40.0	31.40	31.40	40.0	5G10mm ²	0.75.....35mm ²	5G10mm ²	10.....70mm ²
PW110	30.50	30.50	40.0	31.40	31.40	40.0	5G10mm ²	0.75.....35mm ²	5G10mm ²	10.....70mm ²
PW136	30.50	30.50	40.0	31.40	31.40	40.0	5G10mm ²	0.75.....35mm ²	5G10mm ²	10.....70mm ²
PW145	30.50	30.50	40.0	31.40	31.40	40.0	5G10mm ²	0.75.....35mm ²	5G10mm ²	10.....70mm ²
PW161	30.50	30.50	40.0	31.40	31.40	40.0	5G10mm ²	0.75.....35mm ²	5G10mm ²	10.....70mm ²
PW170	35.80	35.80	40.0	37.00	37.00	40.0	5G10mm ²	0.75.....35mm ²	5G10mm ²	10.....70mm ²
PW201	35.80	35.80	40.0	37.00	37.00	40.0	5G10mm ²	0.75.....35mm ²	5G10mm ²	10.....70mm ²

Note:

- Max Electrical Heaters capacity selectable;
- Max Humidifier capacity selectable;
- When connecting the power inputs cable make sure to always use ferrules on cables when they are the smallest accepted size, or when cable is "braided";
- When connecting the power inputs cable make sure to always apply recommended max torque.

6.4.2 Fans

Table 17 - Fans electrical data

Unit model	EC Fan advance - HE			EC Fan advance - HP		
	Motor Size [kW]	FLA @400V/ 50 Hz [A]	FLA @460V/ 60 Hz [A]	Motor Size [kW]	FLA @400V/ 50 Hz [A]	FLA @460V/ 60 Hz [A]
PW025	2.6	4.00	3.47	3.5	5.10	4.10
PW030	2.6	4.00	3.47	3.5	5.10	4.10
For all models	3.5	5.10	4.10	3.5	5.32	4.62

NOTE Values given for each single fan. The model is the same both for 50 Hz and 60 Hz.

6.4.3 Electrical heaters

Table 18 - Electrical heaters data

Unit model	400 V / 3ph / 50 Hz				460 V / 3ph / 60 Hz				380 V / 3ph / 60 Hz			
	Standard Capacity [A]		High Capacity [A]		Standard Capacity [A]		High Capacity [A]		Standard Capacity [A]		High Capacity [A]	
	FLA [A]	Nominal Power [kW]	FLA [A]	Nominal Power [kW]	FLA [A]	Nominal Power [kW]	FLA [A]	Nominal Power [kW]	FLA [A]	Nominal Power [kW]	FLA [A]	Nominal Power [kW]
PW025	10.8	7.5	-	-	9.4	7.5	-	-	11.4	7.5	-	-
PW030	10.8	7.5	-	-	9.4	7.5	-	-	11.4	7.5	-	-
PW035	10.8	7.5	-	-	9.4	7.5	-	-	11.4	7.5	-	-
PW040	10.8	7.5	-	-	9.4	7.5	-	-	11.4	7.5	-	-
PW046	10.8	7.5	-	-	9.4	7.5	-	-	11.4	7.5	-	-
PW045	10.8	7.5	-	-	9.4	7.5	-	-	11.4	7.5	-	-
PW060	10.8	7.5	21.6	15.0	9.4	7.5	18.8	15.0	11.4	7.5	22.8	15.0
PW066	10.8	7.5	21.6	15.0	9.4	7.5	18.8	15.0	11.4	7.5	22.8	15.0
PW070	10.8	7.5	21.6	15.0	9.4	7.5	18.8	15.0	11.4	7.5	22.8	15.0
PW080	10.8	7.5	21.6	15.0	9.4	7.5	18.8	15.0	11.4	7.5	22.8	15.0
PW091	10.8	7.5	21.6	15.0	9.4	7.5	18.8	15.0	11.4	7.5	22.8	15.0
PW095	10.8	7.5	32.5	22.5	9.4	7.5	28.2	22.5	11.4	7.5	34.2	22.5
PW110	10.8	7.5	32.5	22.5	9.4	7.5	28.2	22.5	11.4	7.5	34.2	22.5
PW136	10.8	7.5	32.5	22.5	9.4	7.5	28.2	22.5	11.4	7.5	34.2	22.5
PW145	10.8	7.5	32.5	22.5	9.4	7.5	28.2	22.5	11.4	7.5	34.2	22.5
PW161	10.8	7.5	32.5	22.5	9.4	7.5	28.2	22.5	11.4	7.5	34.2	22.5
PW170	10.8	7.5	32.5	22.5	9.4	7.5	28.2	22.5	11.4	7.5	34.2	22.5
PW201	10.8	7.5	32.5	22.5	9.4	7.5	28.2	22.5	11.4	7.5	34.2	22.5

6.4.4 Electrode humidifier

Table 19 - Electrode humidifier electrical data

Unit model	400 V / 3ph / 50 Hz		460 V / 3ph / 60 Hz		380 V / 3ph / 60 Hz	
	FLA [A]	Nominal Power [kW]	FLA [A]	Nominal Power [kW]	FLA [A]	Nominal Power [kW]
PW025	8.7	6.0	7.5	6.0	9.1	6.0
PW030	8.7	6.0	7.5	6.0	9.1	6.0
PW035	8.7	6.0	7.5	6.0	9.1	6.0
PW040	8.7	6.0	7.5	6.0	9.1	6.0
PW046	8.7	6.0	7.5	6.0	9.1	6.0
PW045	8.7	6.0	7.5	6.0	9.1	6.0
PW060	8.7	6.0	7.5	6.0	9.1	6.0
PW066	8.7	6.0	7.5	6.0	9.1	6.0
PW070	8.7	6.0	7.5	6.0	9.1	6.0
PW080	8.7	6.0	7.5	6.0	9.1	6.0
PW091	8.7	6.0	7.5	6.0	9.1	6.0
PW095	8.7	6.0	7.5	6.0	9.1	6.0
PW110	8.7	6.0	7.5	6.0	9.1	6.0
PW136	8.7	6.0	7.5	6.0	9.1	6.0
PW145	8.7	6.0	7.5	6.0	9.1	6.0
PW161	8.7	6.0	7.5	6.0	9.1	6.0
PW170	8.7	6.0	7.5	6.0	9.1	6.0
PW201	8.7	6.0	7.5	6.0	9.1	6.0

6.4.5 Infrared humidifier

Table 20 - Infrared humidifier electrical data

Unit model	400 V / 3ph / 50 Hz		460 V / 3ph / 60 Hz		380 V / 3ph / 60 Hz	
	FLA [A]	Nominal Power [kW]	FLA [A]	Nominal Power [kW]	FLA [A]	Nominal Power [kW]
PW025	6.9	4.8	6.0	4.8	7.3	4.8
PW030	6.9	4.8	6.0	4.8	7.3	4.8
PW035	6.9	4.8	6.0	4.8	7.3	4.8
PW040	6.9	4.8	6.0	4.8	7.3	4.8
PW046	6.9	4.8	6.0	4.8	7.3	4.8
PW045	13.9	9.6	12.0	9.6	14.6	9.6
PW060	13.9	9.6	12.0	9.6	14.6	9.6
PW066	13.9	9.6	12.0	9.6	14.6	9.6
PW070	13.9	9.6	12.0	9.6	14.6	9.6
PW080	13.9	9.6	12.0	9.6	14.6	9.6
PW091	13.9	9.6	12.0	9.6	14.6	9.6
PW095	13.9	9.6	12.0	9.6	14.6	9.6
PW110	13.9	9.6	12.0	9.6	14.6	9.6
PW136	13.9	9.6	12.0	9.6	14.6	9.6
PW145	13.9	9.6	12.0	9.6	14.6	9.6
PW161	13.9	9.6	12.0	9.6	14.6	9.6
PW170	13.9	9.6	12.0	9.6	14.6	9.6
PW201	13.9	9.6	12.0	9.6	14.6	9.6

6.4.6 Condensate pump

Table 21 - Condensate pump electrical data

Unit model	FLA [A]	Nominal Power [kW]
All models	1,6	0,15

NOTE

- Internal condensate pump kit available for 400 V / 3ph / 50 Hz and 380 V / 3ph / 60 Hz power supply.
- Internal condensate pump kit available for all units except Downflow PW025 and Downflow PW030.
- For 460 V / 3ph / 60 Hz available only external kit.

As an option it is possible to have unit with a condensate pump that allows draining of the water up to 3m above the floor.

The pump discharges both condensate water from exchange coil and drain water from humidifier (if installed).

Maximum discharge total head allowed 3m (head + hydraulic connection loss); the final drain must be able to receive 10 l/min water at high temperature (max water temperature 80°C).

6.5 Noise Level

“Measurement conditions: High Efficiency EC fan module, max airflow”

Table 23 - Sound Power Level [dB] - Downflow up configuration, High Efficiency EC fan module, max airflow

	Unit Model	Level	Octave band frequency (Hz)									Sound level [dB(A)]
			31,5	63	125	250	500	1000	2000	4000	8000	
Downflow Up	PW025	PWL	70.5	70.5	76.4	80.9	83.0	85.0	83.0	78.7	70.7	89.0
		SPL	67.5	67.5	72.8	72.8	65.7	59.3	54.7	46.4	37.9	67.9
	PW030	PWL	70.3	70.3	76.2	80.7	82.8	84.8	82.8	78.5	70.5	88.8
		SPL	67.3	67.3	72.6	72.6	65.5	59.1	54.5	46.2	37.7	67.7
	PW035	PWL	77.0	77.0	81.7	86.3	90.0	91.2	87.0	92.5	77.1	96.8
		SPL	68.4	68.4	73.7	73.7	66.6	60.2	55.6	47.3	38.8	68.8
	PW040	PWL	76.5	76.5	81.2	85.8	89.5	90.7	86.5	92.0	76.6	96.3
		SPL	67.9	67.9	73.2	73.2	66.1	59.7	55.1	46.8	38.3	68.3
	PW046	PWL	80.1	80.1	84.7	89.7	94.4	96.0	91.4	95.3	80.4	100.6
		SPL	47.1	47.1	66.9	70.1	67.3	65.5	61.9	54.4	44.8	70.0
	PW045	PWL	78.1	78.1	82.8	87.4	91.2	92.4	88.1	93.5	78.1	97.9
		SPL	67.9	67.9	73.2	73.2	66.1	59.7	55.1	46.8	38.3	68.3
	PW060	PWL	71.9	71.9	78.1	83.0	86.3	88.1	84.9	83.7	73.3	92.0
		SPL	70.1	70.1	75.4	75.4	68.3	61.9	57.3	49.0	40.5	70.5
	PW066	PWL	82.5	82.5	87.9	92.9	96.8	98.5	94.7	95.7	83.4	102.6
		SPL	50.8	50.8	70.6	73.8	71.0	69.2	65.6	58.1	48.5	73.7
	PW070	PWL	73.7	73.7	79.1	84.0	88.0	89.7	85.8	87.1	74.6	93.9
		SPL	70.0	70.0	75.3	75.3	68.2	61.8	57.2	48.9	40.4	70.4
	PW080	PWL	73.2	73.2	78.6	83.5	87.5	89.2	85.3	86.6	74.1	93.4
		SPL	69.5	69.5	74.8	74.8	67.7	61.3	56.7	48.4	39.9	69.9
	PW091	PWL	83.2	83.2	88.2	93.2	97.6	99.2	95.0	97.4	83.8	103.6
		SPL	50.2	50.2	70.0	73.2	70.4	68.6	65.0	57.5	47.9	73.1
	PW095	PWL	74.7	74.7	80.6	85.5	89.0	90.8	87.4	86.9	75.9	94.8
		SPL	72.1	72.1	77.4	77.4	70.3	63.9	59.3	51.0	42.5	72.5
	PW110	PWL	74.2	74.2	80.1	85.0	88.5	90.3	86.9	86.4	75.4	94.3
		SPL	71.6	71.6	76.9	76.9	69.8	63.4	58.8	50.5	42.0	72.0
	PW136	PWL	84.3	84.3	89.8	94.7	98.6	100.3	96.5	97.4	85.2	104.4
		SPL	52.7	52.7	72.5	75.7	72.9	71.1	67.5	60.0	50.4	75.6
PW145	PWL	74.6	74.6	80.2	85.2	88.9	90.7	87.0	87.3	75.6	94.7	
	SPL	71.0	71.0	76.3	76.3	69.2	62.8	58.2	49.9	41.4	71.4	
PW161	PWL	85.0	85.0	90.1	95.1	99.4	101.0	96.8	99.1	85.7	105.3	
	SPL	52.2	52.2	72.0	75.2	72.4	70.6	67.0	59.5	49.9	75.1	
PW170	PWL	77.0	77.0	83.4	85.4	86.4	89.0	88.2	82.7	75.4	93.4	
	SPL	74.7	74.7	80.0	80.0	72.9	66.5	61.9	53.6	45.1	75.1	
PW201	PWL	86.1	86.1	91.9	96.8	100.4	102.2	98.7	98.5	87.3	106.2	
	SPL	55.0	55.0	74.8	78.0	75.2	73.4	69.8	62.3	52.7	77.9	

Table 24 - Sound Power Level [dB] - Downflow Down configuration, High Efficiency EC fan module, max airflow

	Unit Model	Level	Octave band frequency (Hz)									Sound level [dB(A)]
			31,5	63	125	250	500	1000	2000	4000	8000	
Downflow Down	PW035	PWL	76.0	76.0	80.7	85.3	89.0	90.2	86.0	91.5	76.1	95.8
		SPL	67.4	67.4	72.7	72.7	65.6	59.2	54.6	46.3	37.8	67.8
	PW040	PWL	75.4	75.4	80.1	84.7	88.4	89.6	85.4	90.9	75.5	95.2
		SPL	66.8	66.8	72.1	72.1	65.0	58.6	54.0	45.7	37.2	67.2
	PW046	PWL	79.3	79.3	83.9	88.9	93.6	95.2	90.6	94.5	79.6	99.8
		SPL	46.3	46.3	66.1	69.3	66.5	64.7	61.1	53.6	44.0	69.2
	PW045	PWL	77.1	77.1	81.8	86.4	90.2	91.4	87.1	92.5	77.1	96.9
		SPL	66.9	66.9	72.2	72.2	65.1	58.7	54.1	45.8	37.3	67.3
	PW060	PWL	71.1	71.1	77.3	82.2	85.5	87.3	84.1	82.9	72.5	91.2
		SPL	69.3	69.3	74.6	74.6	67.5	61.1	56.5	48.2	39.7	69.7
	PW066	PWL	82.0	82.0	87.4	92.4	96.3	98.0	94.2	95.2	82.9	102.1
		SPL	50.3	50.3	70.1	73.3	70.5	68.7	65.1	57.6	48.0	73.2
	PW070	PWL	73.0	73.0	78.4	83.3	87.3	89.0	85.1	86.4	73.9	93.2
		SPL	69.3	69.3	74.6	74.6	67.5	61.1	56.5	48.2	39.7	69.7
	PW080	PWL	72.4	72.4	77.8	82.7	86.7	88.4	84.5	85.8	73.3	92.6
		SPL	68.7	68.7	74.0	74.0	66.9	60.5	55.9	47.6	39.1	69.1
	PW091	PWL	82.8	82.8	87.8	92.8	97.2	98.8	94.6	97.0	83.4	103.2
		SPL	49.8	49.8	69.6	72.8	70.0	68.2	64.6	57.1	47.5	72.7
	PW095	PWL	74.1	74.1	80.0	84.9	88.4	90.2	86.8	86.3	75.3	94.2
		SPL	71.5	71.5	76.8	76.8	69.7	63.3	58.7	50.4	41.9	71.9
	PW110	PWL	73.2	73.2	79.1	84.0	87.5	89.3	85.9	85.4	74.4	93.3
		SPL	70.6	70.6	75.9	75.9	68.8	62.4	57.8	49.5	41.0	71.0
	PW136	PWL	83.8	83.8	89.3	94.2	98.1	99.8	96.0	96.9	84.7	103.9
		SPL	52.2	52.2	72.0	75.2	72.4	70.6	67.0	59.5	49.9	75.1
	PW145	PWL	73.5	73.5	79.1	84.1	87.8	89.6	85.9	86.2	74.5	93.6
		SPL	69.9	69.9	75.2	75.2	68.1	61.7	57.1	48.8	40.3	70.3
	PW161	PWL	84.3	84.3	89.4	94.4	98.7	100.3	96.1	98.4	85.0	104.6
		SPL	51.5	51.5	71.3	74.5	71.7	69.9	66.3	58.8	49.2	74.4
PW170	PWL	75.7	75.7	82.1	84.1	85.1	87.7	86.9	81.4	74.1	92.1	
	SPL	73.4	73.4	78.7	78.7	71.6	65.2	60.6	52.3	43.8	73.8	
PW201	PWL	85.5	85.5	91.3	96.2	99.8	101.6	98.1	97.9	86.7	105.6	
	SPL	54.4	54.4	74.2	77.4	74.6	72.8	69.2	61.7	52.1	77.3	

Table 25 - Sound Power Level [dB] - Downflow Up Frontal Air Delivery configuration, High Efficiency EC fan module, max airflow

	Unit Model	Level	Octave band frequency (Hz)								Sound level [dB(A)]	
			31,5	63	125	250	500	1000	2000	4000		8000
Downflow Up Front delivery	PW025	PWL	73.6	73.6	79.5	84.0	86.1	88.1	86.1	81.8	73.8	92.1
		SPL	70.6	70.6	75.9	75.9	68.8	62.4	57.8	49.5	41.0	71.0
	PW030	PWL	73.4	73.4	79.3	83.8	85.9	87.9	85.9	81.6	73.6	91.9
		SPL	70.4	70.4	75.7	75.7	68.6	62.2	57.6	49.3	40.8	70.8
	PW035	PWL	80.3	80.3	85.0	89.6	93.3	94.5	90.3	95.8	80.4	100.1
		SPL	71.7	71.7	77.0	77.0	69.9	63.5	58.9	50.6	42.1	72.1
	PW040	PWL	79.8	79.8	84.5	89.1	92.8	94.0	89.8	95.3	79.9	99.6
		SPL	71.2	71.2	76.5	76.5	69.4	63.0	58.4	50.1	41.6	71.6
	PW046	PWL	84.9	84.9	89.5	94.5	99.2	100.8	96.2	100.1	85.2	105.4
		SPL	51.9	51.9	71.7	74.9	72.1	70.3	66.7	59.2	49.6	74.8
	PW045	PWL	81.4	81.4	86.1	90.7	94.5	95.7	91.4	96.8	81.4	101.2
		SPL	71.2	71.2	76.5	76.5	69.4	63.0	58.4	50.1	41.6	71.6
	PW060	PWL	75.1	75.1	81.3	86.2	89.5	91.3	88.1	86.9	76.5	95.2
		SPL	73.3	73.3	78.6	78.6	71.5	65.1	60.5	52.2	43.7	73.7
	PW066	PWL	87.1	87.1	92.5	97.5	101.4	103.1	99.3	100.3	88.0	107.2
		SPL	55.4	55.4	75.2	78.4	75.6	73.8	70.2	62.7	53.1	78.3
	PW070	PWL	77.0	77.0	82.4	87.3	91.3	93.0	89.1	90.4	77.9	97.2
		SPL	73.3	73.3	78.6	78.6	71.5	65.1	60.5	52.2	43.7	73.7
	PW080	PWL	76.4	76.4	81.8	86.7	90.7	92.4	88.5	89.8	77.3	96.6
		SPL	72.7	72.7	78.0	78.0	70.9	64.5	59.9	51.6	43.1	73.1
PW091	PWL	87.9	87.9	92.9	97.9	102.3	103.9	99.7	102.1	88.5	108.3	
	SPL	54.9	54.9	74.7	77.9	75.1	73.3	69.7	62.2	52.6	77.8	
PW095	PWL	77.9	77.9	83.8	88.7	92.2	94.0	90.6	90.1	79.1	98.0	
	SPL	75.3	75.3	80.6	80.6	73.5	67.1	62.5	54.2	45.7	75.7	
PW110	PWL	77.4	77.4	83.3	88.2	91.7	93.5	90.1	89.6	78.6	97.5	
	SPL	74.8	74.8	80.1	80.1	73.0	66.6	62.0	53.7	45.2	75.2	
PW136	PWL	89.0	89.0	94.5	99.4	103.3	105.0	101.2	102.1	89.9	109.1	
	SPL	57.4	57.4	77.2	80.4	77.6	75.8	72.2	64.7	55.1	80.3	

Table 26 - Sound Power Level [dB] - Upflow up frontal Delivery configuration High Efficiency EC fan module, max airflow

	Unit Model	Level	Octave band frequency (Hz)								Sound level [dB(A)]	
			31,5	63	125	250	500	1000	2000	4000		8000
Upflow	PW025	PWL	67.4	67.4	73.3	77.8	79.9	81.9	79.9	75.6	67.6	85.9
		SPL	64.4	64.4	69.7	69.7	62.6	56.2	51.6	43.3	34.8	64.8
	PW030	PWL	67.3	67.3	73.2	77.7	79.8	81.8	79.8	75.5	67.5	85.8
		SPL	64.3	64.3	69.6	69.6	62.5	56.1	51.5	43.2	34.7	64.7
	PW035	PWL	73.2	73.2	77.9	82.5	86.2	87.4	83.2	88.7	73.3	93.0
		SPL	64.6	64.6	69.9	69.9	62.8	56.4	51.8	43.5	35.0	65.0
	PW040	PWL	72.8	72.8	77.5	82.1	85.8	87.0	82.8	88.3	72.9	92.6
		SPL	64.2	64.2	69.5	69.5	62.4	56.0	51.4	43.1	34.6	64.6
	PW046	PWL	77.5	77.5	82.1	87.1	91.8	93.4	88.8	92.7	77.8	98.0
		SPL	44.5	44.5	64.3	67.5	64.7	62.9	59.3	51.8	42.2	67.4
	PW045	PWL	74.5	74.5	79.2	83.8	87.6	88.8	84.5	89.9	74.5	94.3
		SPL	64.3	64.3	69.6	69.6	62.5	56.1	51.5	43.2	34.7	64.7
	PW060	PWL	68.7	68.7	74.9	79.8	83.1	84.9	81.7	80.5	70.1	88.8
		SPL	66.9	66.9	72.2	72.2	65.1	58.7	54.1	45.8	37.3	67.3
	PW066	PWL	79.8	79.8	85.2	90.2	94.1	95.8	92.0	93.0	80.7	99.9
		SPL	48.1	48.1	67.9	71.1	68.3	66.5	62.9	55.4	45.8	71.0
	PW070	PWL	74.8	74.8	80.2	85.1	89.1	90.8	86.9	88.2	75.7	95.0
		SPL	71.1	71.1	76.4	76.4	69.3	62.9	58.3	50.0	41.5	71.5
	PW080	PWL	69.6	69.6	75.0	79.9	83.9	85.6	81.7	83.0	70.5	89.8
		SPL	65.9	65.9	71.2	71.2	64.1	57.7	53.1	44.8	36.3	66.3
PW091	PWL	80.6	80.6	85.6	90.6	95.0	96.6	92.4	94.8	81.2	101.0	
	SPL	47.6	47.6	67.4	70.6	67.8	66.0	62.4	54.9	45.3	70.5	
PW095	PWL	71.4	71.4	77.3	82.2	85.7	87.5	84.1	83.6	72.6	91.5	
	SPL	68.8	68.8	74.1	74.1	67.0	60.6	56.0	47.7	39.2	69.2	
PW110	PWL	71.2	71.2	77.1	82.0	85.5	87.3	83.9	83.4	72.4	91.3	
	SPL	68.6	68.6	73.9	73.9	66.8	60.4	55.8	47.5	39.0	69.0	

NOTE:

The sound levels global and for each octave band are expressed in dB with a tolerance of (0/+2) dB.

PWL - Sound Power Level calculated according to ISO 3744 procedure method.

SPL - Sound Pressure Level measured in free field conditions and at 2 meters from the front of the unit and 1,5 meters above the surface according to ISO 3744 average method.

All **PCW** units have very high noise emission at maximum airflow.

Relevant expected values of Sound level dB(A) for lower airflow can be found in technical literature and simulation software.

7. Handling

Content of this chapter

7.1 Safety Instructions.....	49	7.4 Unpacking.....	51
7.2 Inspection.....	49	7.5 Transport without Package.....	51
7.3 Transport with Package.....	50	7.5.1 Using piano jacks.....	51
7.3.1 Using a fork lift or a pallet jack.....	50	7.5.2 Using a crane.....	52
7.3.2 Using a crane.....	50		

This chapter explains how to handle the unit or its modules in the following situations.

- Shipping
- Moving to a storehouse
- Moving to the installation site.

7.1 Safety Instructions



WARNING

Improper operations can cause injury or death.

Verify that all the lifting and moving equipment is rated for the weight of the unit before attempting to move, lift, remove packaging from or prepare the unit for installation.

Make reference to the local safety regulations about lifting and handling heavy loads.



NOTICE

Improper operations can cause product damage.



NOTICE

Improper storage can cause product damage.

Keep the unit in a storehouse with the ambient conditions given in *3.6.1 Storage conditions*.



Read carefully the chapter *1. Safety*.

Pay attention to the safety labels on the unit and to the safety warnings in this chapter.

7.2 Inspection

- After receiving the product, check the accessories against the packing list.
- If any parts are found missing or damaged, please report to the carrier immediately.
- If you find any damage, please report to the carrier and to the local distributor too.

7.3 Transport with Package

NOTE The following instructions are valid both for standard units and for the modules of the extended units (coil module and fan module).

7.3.1 Using a fork lift or a pallet jack

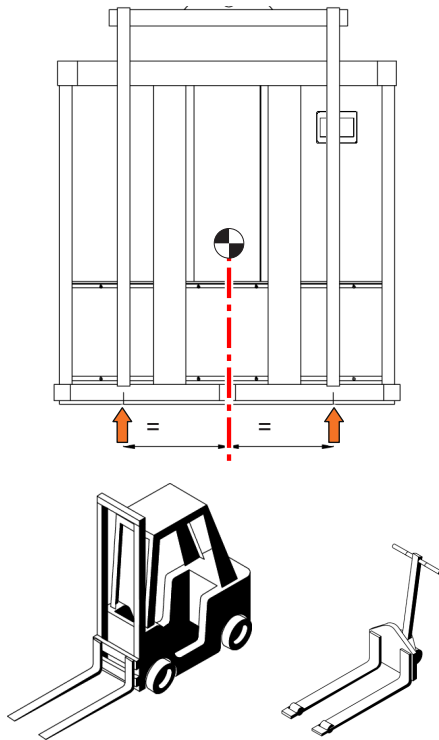

- Make sure that the fork length and distance is suitable for the unit length and to ensure the unit stability.
- Spread the forks to the widest allowable distance to still fit under the skid.
- Lift the unit from the side that is indicated in the instructions on the package.
- Make reference to the local safety regulations about lifting and handling heavy loads.



WARNING

Pay attention to overhead obstacles, for example doorways.

7.3.2 Using a crane

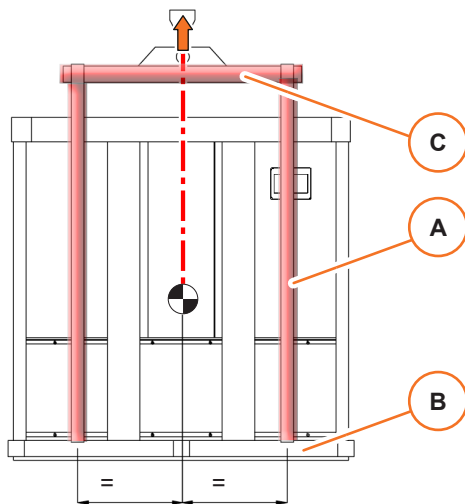

- Place the slings [A] between the unit bottom rails and the skid [B], at the widest allowable distance.
- Be sure that the distance between slings guarantees the unit stability.
- Fix the slings to the spreader bar [C]



NOTICE

Lift the unit with a speed suitable for the load to be moved, so as not to damage the structure.

7.4 Unpacking

NOTE The following instructions are valid both for standard units and for the modules of the extended units (coil module and fan module).

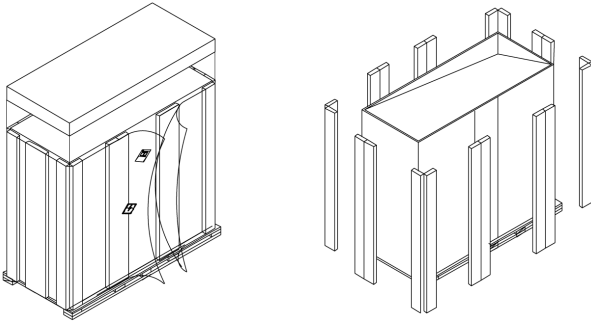

- Remove the exterior packaging material from around the unit.
- Remove the top cover, the corner and the side planks.



ENVIRONMENT

All material used to package this unit is recyclable. Please save for future use, or dispose the package materials according to the local regulation about waste disposal.

7.5 Transport without Package

NOTE The following instructions are valid both for standard units and for the modules of the extended units (coil module and fan module).

7.5.1 Using piano jacks

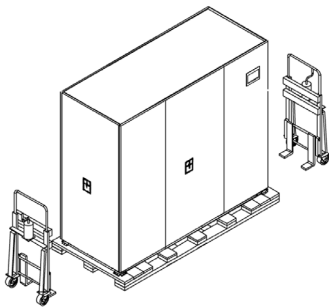

- Make sure that the floor can support the unit when you move it by piano jacks. If necessary, cover the floor by metal plates or other support that can distribute the weight on the floor.
- Place the piano jacks at the two sides of the unit.

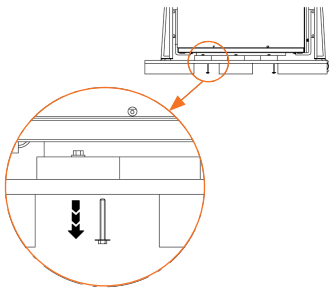

- Remove the four bolt (two at each side) that fix the unit to the skid.

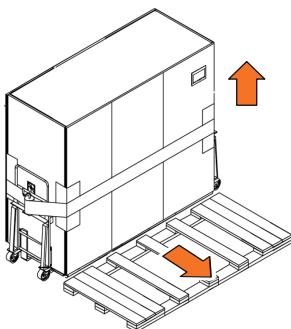

- Slide the forks of the piano jacks between the unit and the pallet.
- Place a protective material between the unit and the piano jacks.
- Fix the piano jacks to the unit by straps, placing a protective material between the unit and the straps.
- Lift slightly the forks of the piano jacks and remove the pallet.

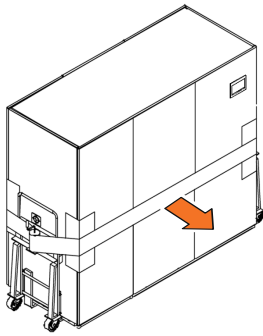

- Move the unit to its installation site.



CAUTION

At least two persons are needed.

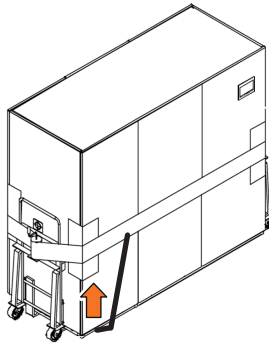

- Remove the piano jacks
- Place the unit as low as the piano jacks allow.
- Remove all the straps.
- Using a pry bar or a similar tool, lift the unit at one side high enough to remove the piano jack.
- Do the same on the other side.
- Remove the protecting materials.

7.5.2 Using a crane

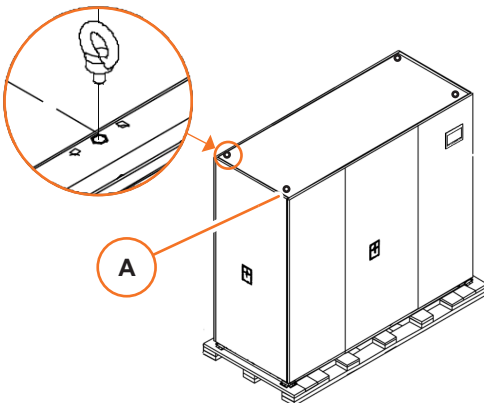

- Get four eyebolts M8 that suitable to hold the full weight of the unit (they are not supplied with the unit).
- Insert the eyebolts in each of the holes [A].

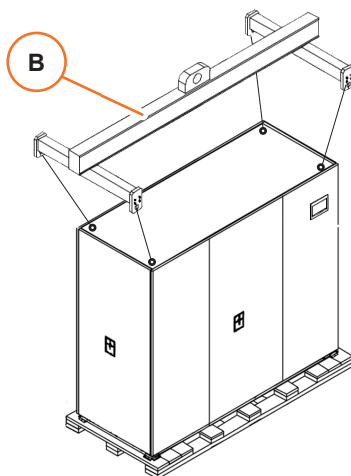

- Insert a sling or a chain in each of the eyebolts.
- Fix the slings or chains to a 4-points lifting bar [B].

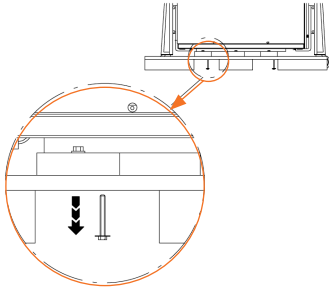

- Remove the four bolts (two at each side) that fix the unit to the skid.
- By a crane or bridge crane, lift slightly the unit and remove the skid.
- Move the unit to its installation site.

**NOTICE**

Lift the unit with a speed suitable for the load to be moved, so as not to damage the structure.

8. Assembly and Positioning

Content of this chapter

8.1 Safety Instructions.....	55	8.3.4 Arrange the top bottom chilled water piping (optional).....	59
8.2 Overview.....	55	8.4 Assembling an Extended Downflow Unit.....	60
8.2.1 Assembly.....	55	8.4.1 Prepare.....	60
8.2.2 Positioning.....	56	8.4.2 Fix the modules together.....	61
8.3 Assembling an Extended Upflow Unit.....	57	8.4.3 Arrange the cables and close the fan module.....	62
8.3.1 Prepare.....	57	8.4.4 Arrange the bottom chilled water piping (optional).....	62
8.3.2 Arrange the cables.....	58	8.5 For Downflow units - Arrange the drain piping.....	63
8.3.3 Fix the modules together and close the fan module.....	58		

8.1 Safety Instructions



WARNING

Improper operations can cause injury or death.



NOTICE

Improper operations can cause product damage.



Read carefully the chapter *1. Safety*.

Pay attention to the safety labels on the unit and to the safety warnings in this chapter.

8.2 Overview

8.2.1 Assembly

- Move the unit or the modules close to the final position as explained in *7. Handling*.
- If necessary, assemble the modules as explained below.

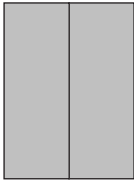
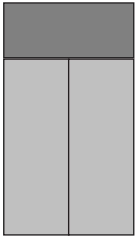
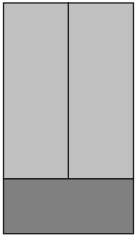
Standard height	Extended height Upflow	Extended height Downflow
		
<p>The unit is already assembled.</p>	<p>Assemble the fan module on top of the coil module. See <i>8.3 Assembling an Extended Upflow Unit</i></p>	<p>Assemble the coil module on top of the fan module See <i>8.4 Assembling an Extended Downflow Unit</i></p>

NOTE For all the above versions, if you need to assemble any accessory see *Annex F - Accessories*.

8.2.2 Positioning

- Move the unit to its final position as explained in 7. *Handling*
- Place the unit as explained below.

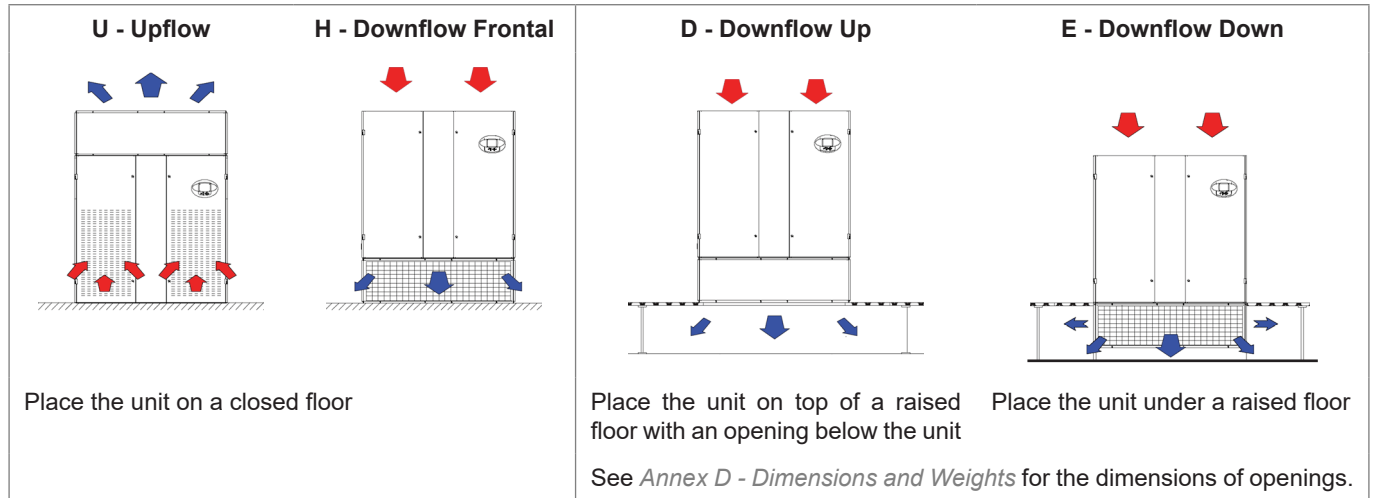

NOTICE

See 9. *Installation* for specifications about the installation site.
Ensure isolation between the unit and the floor to avoid transmission of vibration.



NOTICE

The **Downflow Down** units must be placed at the right height with respect to the floor level.
Provide the right support under the unit.
See *Annex F - Accessories* for the available support systems.



NOTICE

The unit may contain special brackets or supports that secure some elements for the transport. They are highlighted by special labels.
When you finish assembly and positioning of the unit, make sure that all the transport brackets and supports have been removed.

8.3 Assembling an Extended Upflow Unit

8.3.1 Prepare

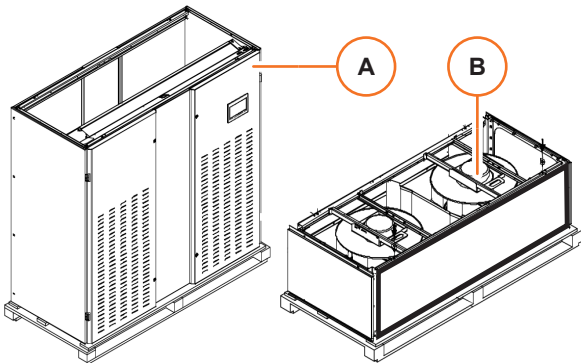

- Place the coil module [A] and the fan module [B] close to the final position.

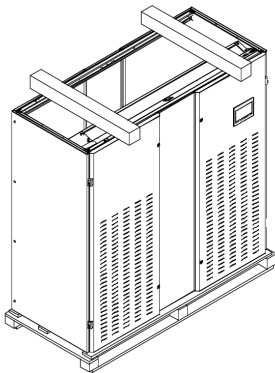

- Place two timber pieces on top of the coil module.

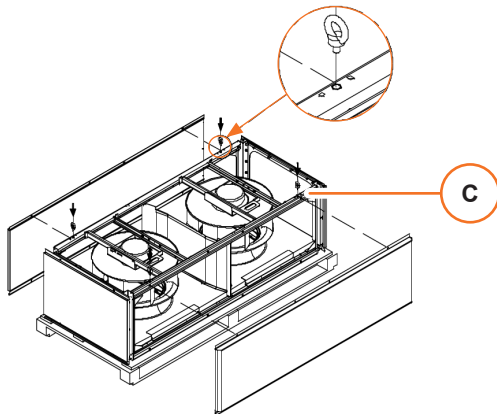

- Remove the front and back panels from the fan module.
- Get four eyebolts M8 that are suitable to hold the full weight of the fan module (they are not supplied with the unit).
- Insert the eyebolts in each of the holes [C].

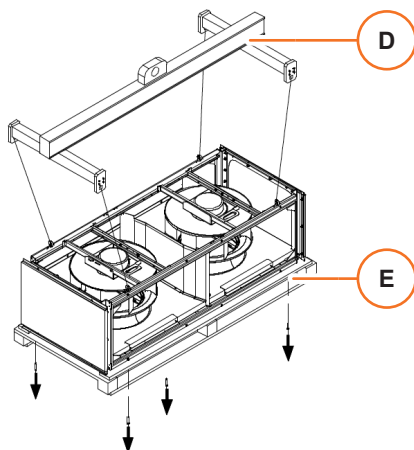

- Insert a sling or a chain in each of the eyebolts.
- Fix the slings or chains to a 4-points lifting bar [D].
- Remove the four bolts [E] (two at each side) that fix the fan module to the skid.

8.3.2 Arrange the cables

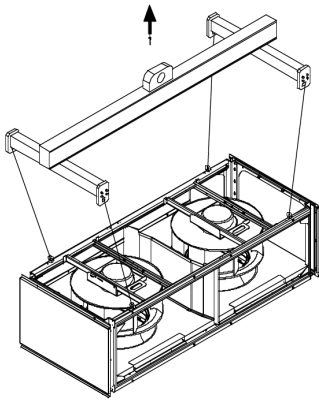

- Lift the fan module by a crane and place it on top of the coil module.

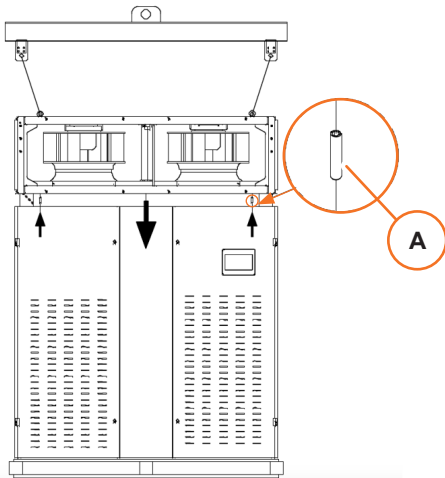

- Insert four M8 dowels [A] in the lower frame of the fan module.
- Take from the coil module the power cable and the Modbus cable that are ready for the connection with the correspondent cables of the fan module.
- Insert the cables through the bushing into the fan module.
- Connect the power cable of the coil module with the power cable of the fan module.
- Connect the Modbus cable of the coil module with the Modbus cable of the fan module.
- If installed, connect all the electrical heaters cables to the electrical connectors inside the electrical panel lower duct:
 - **Standard Capacity:** connect the electrical heaters cables to the connector Xp5.
 - **High Capacity (PI092):** connect the electrical heaters cables to the connectors Xp5 and Xp6.
 - Electrical Heater thermostats
 - Temperature sensor
- Place the cover provided with the unit to protect the connections. Fix the cover to the frame by screws.

See 9.5 *Electrical connections* for details.

8.3.3 Fix the modules together and close the fan module

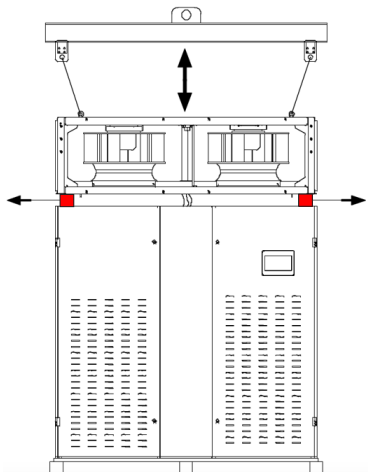

- Lift slightly the fan module.
- Remove the two wooden pieces.

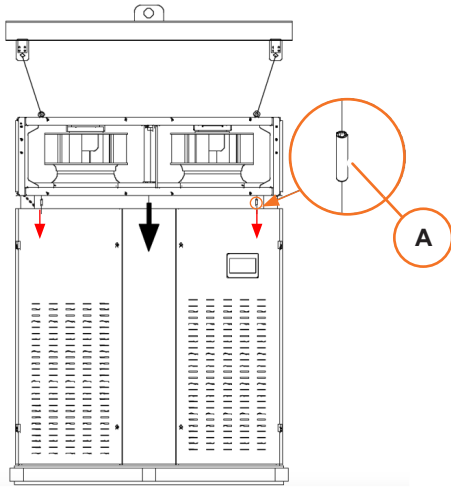

- Lower the fan module to the coil module.
- Use the four dowels [A] for centering the fan module with the coil module.



NOTICE

Pay attention not to damage the cables.
Pull the cables through the coil module.

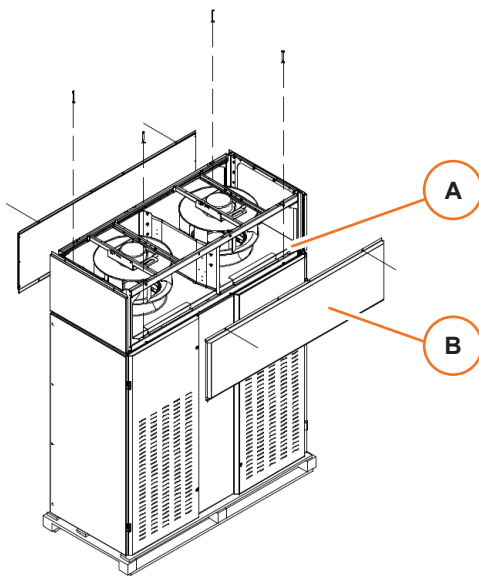

- Fix the two modules by the four hex head screws supplied with the unit.
- Mount the front and back panels on the fan module.

The unit is ready for positioning.

8.3.4 Arrange the bottom chilled water piping (optional)

Extended upflow - top piping

Connect two piping stubs to the piping inside the unit.
The piping ends are located behind the unit's door.

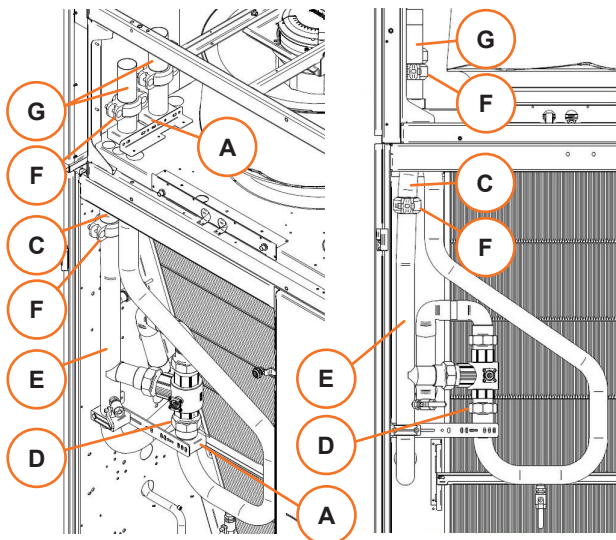

- Open the coil and the fan modules.
- Remove the necessary support connection clamps [A] for mounting the piping.
- Prepare the two pipe sections [B] and [C] that are delivered with the unit.
- Connect the pipe section [B], which is provided with a union nut, directly to the outlet of the valve thread [D]. Use a gasket to join the pipe to the valve threaded connection.
- Connect the other pipe section [C] to the water inlet pipe [E].
- You may use a threaded connection (up to diameter 42 mm) or grooved [F] connection (See 9.4.4 *Joining pipes with grooved connections* for instructions).
- Fix the pipes in the fan module by pipe clamps.
- Seal any free space in the pipe passage through the upper panel to prevent air by-pass.
- Fix the support connection bracket [A].

[A]	Support connection bracket
[B]	Pipe section
[C]	Other pipe section
[D]	Outlet of the valve
[E]	Water inlet pipe
[F]	Grooved connection
[G]	Smooth pipe stubs

8.4 Assembling an Extended Downflow Unit

8.4.1 Prepare

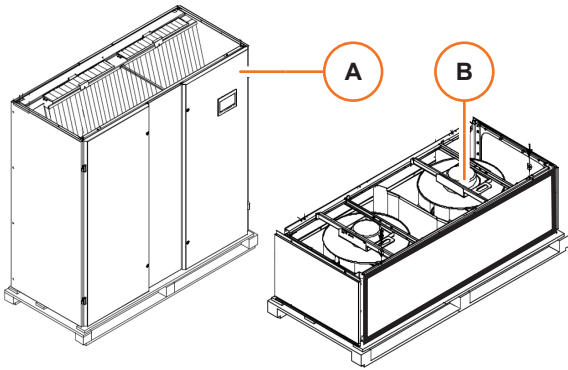

- Place the coil module [A] and the fan module [B] close to the final position.

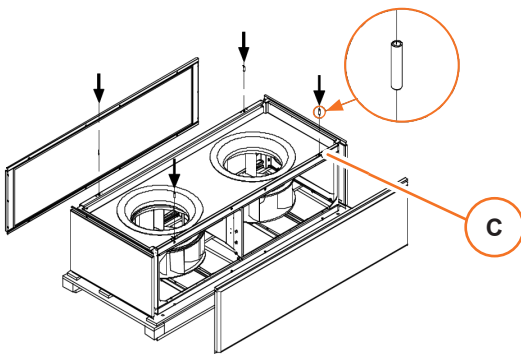

- Remove the front and back panels from the fan module.
- Insert four M8 dowels [C] in the upper frame of the fan module.

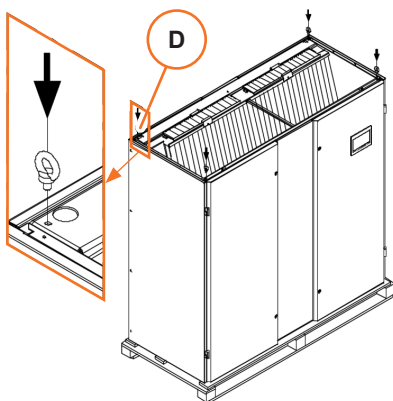

- Get four eyebolts M8 that are suitable to hold the full weight of the unit (they are not supplied with the unit).
- Insert the eyebolts in each of the holes [D].

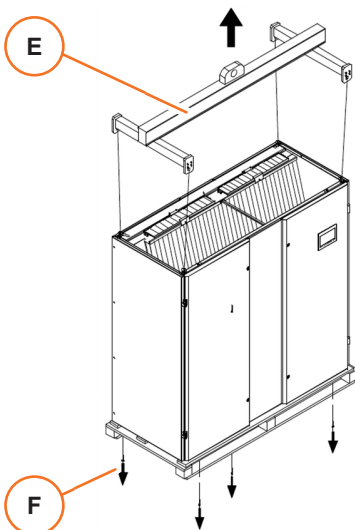

- Insert a sling or a chain in each of the eyebolts.
- Fix the slings or chains to a 4-points lifting bar [E].
- Remove the four bolts [F] (two at each side) that fix the coil module to the skid.

8.4.2 Fix the modules together

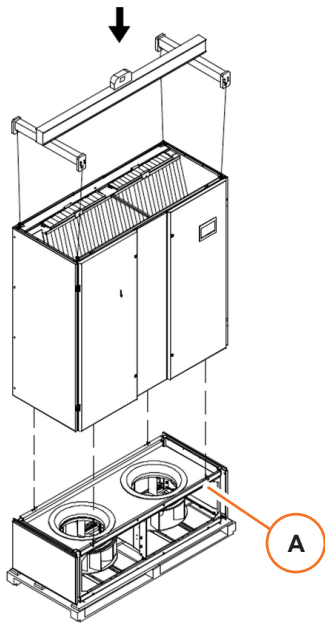

- Lift the coil module by a crane and place it on top of the fan module.
- Use the four dowels [A] for centering the fan module with the coil module.

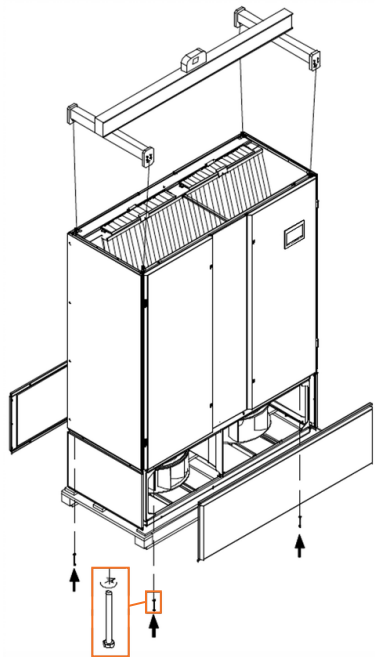

- Fix the two modules by the four hex head screws supplied with the unit.

8.4.3 Arrange the cables and close the fan module

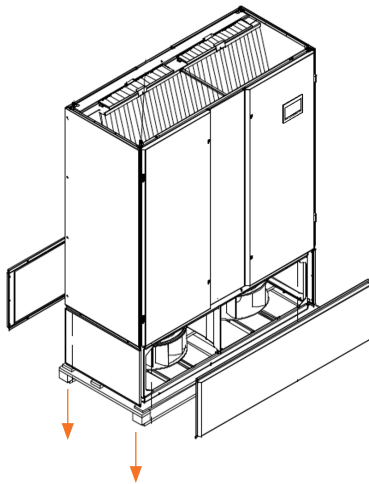

- Take from the coil module the power cable and the Modbus cable that are ready for the connection with the correspondent cables of the fan module.
- Insert the cables through the bushing into the fan module.
- Connect the power cable of the coil module with the power cable of the fan module.
- Connect the Modbus cable of the coil module with the Modbus cable of the fan module.
- If installed, connect all the electrical heaters cables to the electrical connectors inside the electrical panel lower duct:
 - **Standard Capacity:** connect the electrical heaters cables to the connector Xp5.
 - **High Capacity (PI092):** connect the electrical heaters cables to the connectors Xp5 and Xp6.
 - Electrical Heater thermostats
 - Temperature sensor
- Place the cover provided with the unit to protect the connections. Fix the cover to the frame by screws.

See 9.5 *Electrical connections* for details.

- Remove the four bolts that fix the fan module to the skid.
- Mount the front and back panels on the fan module.

The unit is ready for positioning.

8.4.4 Arrange the bottom chilled water piping

Extended downflow - bottom piping

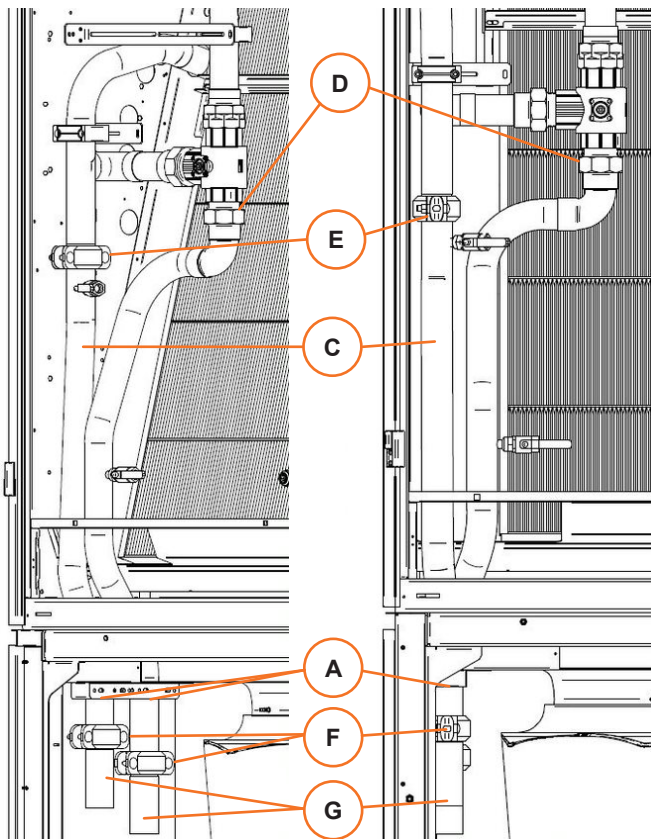

Open the coil and the fan modules.

- If necessary, you may remove the plate [I] on the drain pan by unscrewing 4 screws.
- To get all the screws, you may remove the closer air filter (see 11.5.2 *Replacing an air filter*).
- For units with double chilled water circuit, swing the electrical panel [H] to connect the two pipe sections to the right chilled water valve.
- Prepare the two pipe sections [B] and [C] that are delivered with the unit.
- Connect the pipe section [B], which is provided with a union nut, directly to the outlet of the valve [D]. Use a gasket to join the pipe to the valve threaded connection.
- Connect the other pipe section [C] to the water inlet pipe [E].
- You may use a threaded connection or grooved connection (See 9.4.4 *Joining pipes with grooved connections* for instructions).
- Fix the pipes in the fan module by pipe clamps [A].
- Mount again the plate [I] on the drain panel (if it has been removed).
- Mount again the air filter (if it has been removed)
- Seal any free space in the pipe passage through the lower panel to prevent air by-pass.
- Fix the support connection bracket [A].

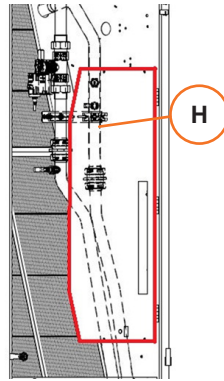
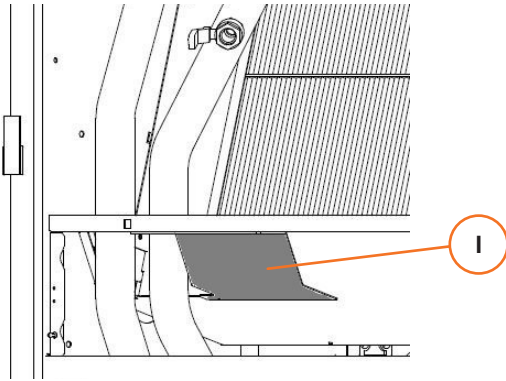

[A]	Support connection bracket
[B]	Pipe section
[C]	Other pipe section
[D]	Outlet of the valve
[E]	Water inlet pipe
[F]	Grooved connection
[G]	Smooth pipe stubs
[H]	Electrical panel
[I]	Plate on the drain pan

8.5 For Downflow units - Arrange the drain piping

The following instructions are valid both for standard and extended **Downflow Up** and **Downflow Down** unit



- Remove the internal bottom cover by unscrewing the two screws that hold it.



- Remove the drainpipe from the hole on the drain panel by pulling it down.

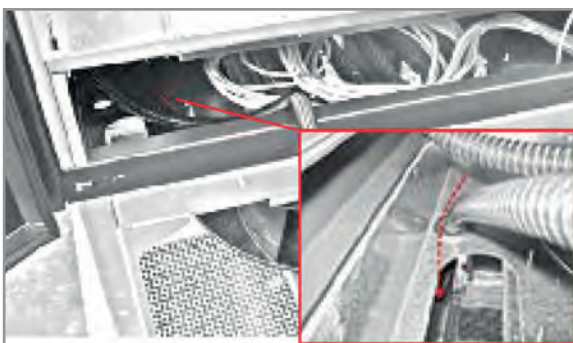

- Pass the drain pipe through the cable bushing on the top of the fan module along the entire tube length.

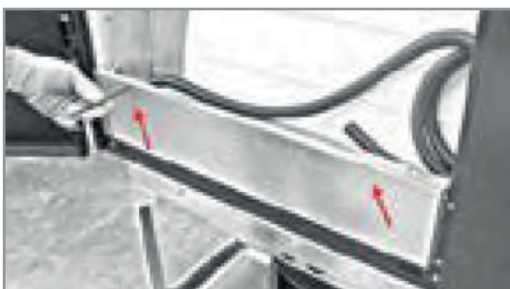

- Reposition the internal bottom panel and fix it with the two screws.

9. Installation

Content of this chapter

9.1 Safety Instructions.....	65	9.5 Electrical connections.....	75
9.2 Overview.....	65	9.5.1 Power supply cable.....	75
9.2.1 Preparation of the installation site (by the customer).....	65	9.5.2 Contacts for the unit status signals.....	76
9.2.2 Operations on the unit.....	66	9.5.3 Sensors connections.....	77
9.3 Specifications for Site Preparation.....	67	9.5.4 Supplyair temperature sensor.....	77
9.3.1 Location.....	67	9.6 Modbus Connections and Settings.....	78
9.3.2 Space requirements.....	67	9.6.1 Connection of a device to the Modbus cable.....	78
9.3.3 Chilled water piping requirements.....	67	9.6.2 Setting of Modbus devices.....	78
9.3.4 Hot water piping requirements (optional).....	68	9.7 Filling the water system.....	80
9.3.5 Condensate piping requirements.....	68	9.7.1 Water supply.....	80
9.3.6 Water supply requirements.....	69	9.7.2 Adding the ethylene glycol.....	81
9.3.7 Electric system requirements.....	69	9.8 Final Checks.....	82
9.4 Piping Connections.....	71		
9.4.1 General instructions.....	71		
9.4.2 Chilled water.....	72		
9.4.3 Hot water (optional).....	72		
9.4.4 Joining piping with VICTUALIC® connections.....	72		
9.4.5 Condensate drain without condensate pump.....	74		
9.4.6 Condensate drain with condensate pump.....	74		

9.1 Safety Instructions



WARNING

Improper operations can cause injury or death.



NOTICE

Improper operations can cause product damage.



Read carefully the chapter *1. Safety*.

Pay attention to the safety labels on the unit and to the safety warnings in this chapter.

9.2 Overview

9.2.1 Preparation of the installation site (by the customer)



NOTICE

Vertiv™ takes no responsibility for systems not compliant with the specifications given in this manual.

Lack of compliance to the specifications given by Vertiv™ voids the warranty.

The customer is responsible for the following operations.

Operation	See ...
Prepare the area	9.3.1 Location and 9.3.2 Space requirements
Prepare the piping for the connection of the unit to the facility systems (chilled water, hot water, drainage)	9.3.3 Chilled water piping requirements 9.3.4 Hot water piping requirements (optional) 9.3.5 Condensate piping requirements

Operation	See ...
Make sure that the water supply is suitable	9.3.6 <i>Water supply requirements</i>
Prepare the electric system	9.3.7 <i>Electric system requirements</i>

9.2.2 Operations on the unit

The following operations must be done on the unit at the installation site:

Operation	See ...
1. For extended height versions, assemble the fan module and the coil module	8. <i>Assembly and Positioning</i>
2. Assemble any optional accessory	<i>Annex E - Accessories</i>
3. Position the unit at the final location and fix it on the floor or the supporting structure	8. <i>Assembly and Positioning</i>
4. Connect the unit to the chilled water system	9.4 <i>Piping Connections</i>
5. Connect the unit to the hot water system (optional)	
6. Connect the unit to the drain system	
7. Connect the water supply and the water drain piping of the humidifier	Depending on the humidifier model - <i>Annex F - Electrode Humidifier</i> - <i>Annex G - Infrared Humidifier</i> - <i>Annex H - Ultrasonic Humidifier</i>
8. Connect the electric power supply	- 9.5.1 <i>Power supply cable</i>
9. Connect the electric equipment to the electric panel	- 9.5.2 <i>Contacts for the unit status signals</i> - 9.5.3 <i>Sensor connections</i>
10. Check or adjust the Modbus settings	9.6 <i>Modbus Connections and Settings</i>
11. Fill the chilled water system	9.7.1 <i>Water supply</i>
12. Fill the hot water system (optional)	
13. Fill the ethylene glycol (for low outdoor temperature only)	9.7.2 <i>Adding ethylene glycol</i>
14. Check the whole system	9.8 <i>Final Checks</i>
15. Start the unit	10. <i>Operation</i>

9.3 Specifications for Site Preparation

9.3.1 Location

- The units must be installed indoors, in rooms protected from weather agents.
- Before installing the unit, determine whether any building alterations are required to run piping, wiring and ductwork.
- Prepare a level surface suitable to support the weight of the unit.
- Install the unit in an area with clean air, away from loose dirt and foreign matter.

9.3.2 Space requirements

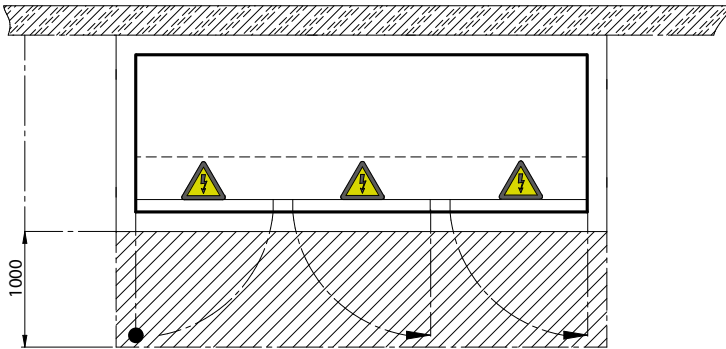

- See *Annex C - Dimensions and Weights* for the unit dimensions
- Keep a free space between the unit and any obstacle as shown in the figure.



WARNING

Leave a free space of at least 1000 mm on the front to allow safe installation and maintenance operations.

9.3.3 Chilled water piping requirements

Prepare the piping for connecting the main unit according to the following specifications.

See also *Annex D - Connections* for details about the unit piping (dimensions and position).

Material	Use copper or steel (Mannesmann) tubing.		
Threaded connections	All units with connection pipes diameter up to 42 mm (see chapter <i>Annex D - Connections x.xx</i>). In case of threaded connections use hemp and paste to get a reliable pressure - tight joint.		
Grooved connections	Units with connection diameter 54 or 64 mm are supplied with grooved connections and smooth pipe stubs - see picture. On-site chilled water piping must be suitable for grooved connections or can be connected by brazing. See the following table for the grooved connections details		

Dimension	Tolerance	Nominal size		
		54 mm	64 mm	
Actual outside diam.	Min.	---	53,93	63,93
	Max.	---	54,07	64,07
Gasket seat	A	± 0,8 mm	15,87	15,87
Groove width	B	± 0,8/- 0 mm	7,62	7,62
Groove diameter	C	± 0/- 0,5 mm	51,50	61,46
Groove depth	D	Ref. only	1,25	1,27
Max allowed flare diameter	---	---	56,41	66,41

All dimensions are given in [mm].

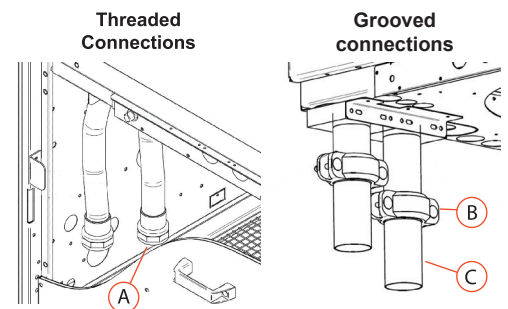

- A** - Threaded connections
- B** - Grooved connections
- C** - Smooth Pipe stubs

Diameter and thickness

NOTICE The guarantee becomes invalid if you do not respect the diameters given in this manual. If you need to use piping with a larger diameter (for example for long winding runs), please contact Vertiv™ Technical Support.

Thermal insulation

Wrap the piping by thermal insulating material such as Armaflex

Piping layout

Prepare the external piping as following:

- Place shut-off ball valves [A] at the conditioner inlet and outlet to allow easy maintenance.
- It is advisable to install a thermometer and a manometer [B] on the unit inlet and outlet.
- Install a drain valve [C] at the lowest point in the circuit.
- Place the piping on supporting brackets [D].
- Insulate both pipes using Armaflex insulation [E].

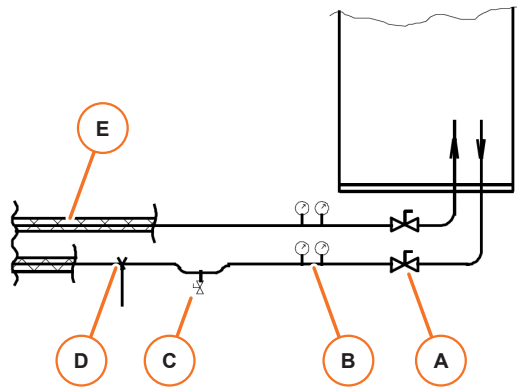

9.3.4 Hot water piping requirements (optional)

Prepare the piping for connecting the unit to the hot water system according to the following specifications

Material

Use copper or steel (Mannesmann) tubing.

Connections

The units are provided with smooth pipe stubs, ready for the connection by brazing.

Diameter and thickness

NOTICE The guarantee becomes invalid if you do not respect the diameters given in this manual. If you need to use piping with a larger diameter (for example for long winding runs), please contact Vertiv™ Technical Support.

Thermal insulation

Wrap the piping by thermal insulating material with closed cells (such as Armaflex).

9.3.5 Condensate piping requirements

Prepare the piping for connecting the unit to the condensate drain system according to the following specifications

	Without condensate pump	With condensate pump (optional for Upflow units)
Material	Galvanized steel, PVC or flexible polythene tubing.	
Connections	The units are provided with smooth pipe stubs, ready for the connection by brazing.	
Piping layout	The drain pipe must have at least a 2% gradient from the unit outlet to the connection to the site drainage system.	Maximum discharge total head allowed 3 m (head + hydraulic connection loss). The final drain must be able to receive 1 l/min water at high temperature (max water temperature 100 °C).

9.3.6 Water supply requirements

NOTE *The following instructions refer both to chilled water and to hot water*

Analyze the water It is the user's responsibility to establish the quality of the water and make sure that this is compatible with the materials used in the exchangers.
 The quality of water may significantly affect the operation and the life of the exchangers.
 The first step in the planning the treatment of the water is chemical analysis, which must be performed by qualified personnel from specialist organizations
 Water quality has to be in accordance with VDI 2035.

Add water softeners In tower water, the tendency to form deposits may be high: to reduce this phenomenon, there are various types of water softening treatments available, including the use of ion exchange resins.

Prevent corrosion The oxygen dissolved in water increases the rate of corrosion.
 The main factors causing corrosion are sulphur and carbon dioxide acids (see the Langelier and Ryznar indices).
 A combined effect of fouling due to dust and organic material provides a support for bacteria, fungi and algae; the growth of organisms may produce an oxygen gradient and this results in rather severe pitting of the metallic surface.
 The phenomenon of corrosion is obviously related to the material used on the liquid side of the heat exchanger.
 The table on the right shows the reference values for corrosion on copper, these values must be considered as guidelines to avoid corrosion.

pH	---	7,5 - 9,0
SO ₄	ppm	< 100
HCO ₃ / SO ₄	---	>10
Total hardness	dH	4,5 - 8,5
CJ-	ppm	< 50
PO ₄ ³⁻	ppm	< 2,0
NH ₃	ppm	< 0,5
Free Chlorine	ppm	< 0,5
Fe ³⁺	ppm	< 0,5
Mn ⁺⁺	ppm	< 0,05
CO ₂	ppm	< 50
H ₂ S	ppb	< 50
Temperature	°C	< 65
Oxygen content	ppm	< 0,1

9.3.7 Electric system requirements

Power supply requirements for the unit

- Check the electrical data on the label applied on the unit.
- Check that the available power supply is consistent with the unit power requirements given in 6. *Technical Data*.
- Refer to the electrical schematic supplied with the unit when making line voltage supply, low voltage main unit interlock and any low voltage alarm connections.

Local codes

- Electrical service must conform to national and local electrical codes.
- All wiring must be done in accordance with all applicable local, state, and national electrical codes.

External disconnecting switch

- The final customer must install on site an external disconnecting switch, easy to reach, to facilitate a quick and easy shutdown and power cut off of the unit

Protection

- Select and install the line side electrical supply wire and over current protection device(s) according to the specifications on the unit nameplate(s), per the instructions in this manual and according to the applicable national, state, and local code requirements.
- The customer is responsible for the system protection.
- Protect the system by a differential switch.
- If the system includes devices with inverter, then use a type B or B++ RCD (Residual Current Device) switch.

Power supply variability

- Check that the maximum unbalance between the phases does not exceed the value given in 6. *Technical Data*.
- Make sure to comply with the following data:
 - Electrical voltage between 0.9 and 1.1 nominal voltage
 - Frequency between 0.99 and 1.01 the nominal frequency
 - Variability of supply voltage less than 2%

See the figure below for variability evaluation.

Example of calculating phase to phase variability

1) The 400 V supply has the following variability:

$$RS = 388 \text{ V}$$

$$ST = 401 \text{ V}$$

$$RT = 402 \text{ V}$$

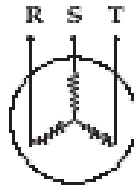

2) The average voltage is:

$$\frac{388 + 401 + 402}{3}$$

3) The maximum deviation from the average is:

$$402 - 397 = 5 \text{ V}$$

4) The phase to phase variability is:

$$\frac{5}{397} \times 100 = 1.26 \text{ (acceptable)}$$

Power supply connection

The units are equipped with electrical devices (power supplies module, control devices,...) that are designed to operate properly with star-connected power (Wye) with earthed neutral (TN or TT system).

If you need three-phase distribution Delta-connected (Δ) or Star-connected power (Wye) without ground or floating ground (IT) please contact Vertiv™ Technical Support.

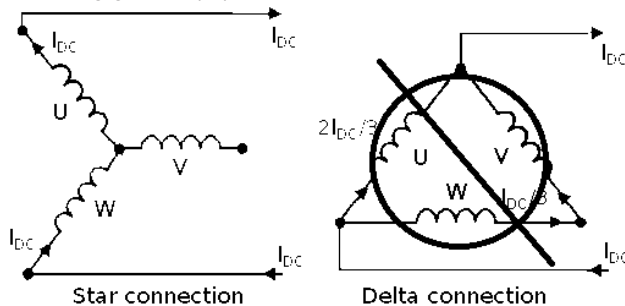

Power supply type

Acceptable:

- TT, TN-S, TN-C, TN-C-S systems
- 460 V Wye with solidly grounded neutral (266 V line to ground)
- 380 V Wye with solidly grounded neutral (220 V line to ground)

Unacceptable:

- 380 to 460 V Wye without ground connection or with high-resistance (or impedance) ground (IT).
- 380 to 460 V Δ without ground or with high-resistance (or impedance) ground (IT).
- 380 to 460 V Δ with corner ground or with grounded center-tapped.

Cables type

- Use copper wiring only.

The units are equipped with electrical panel with one disconnecting switch for the power section.

Choose a supply cable (four- pole type with ground) for the power section, according to:

- the local norms
- the system absorption (FLA unit)
- the system voltage
- installation type
- cable length
- upstream protection

Cables connection

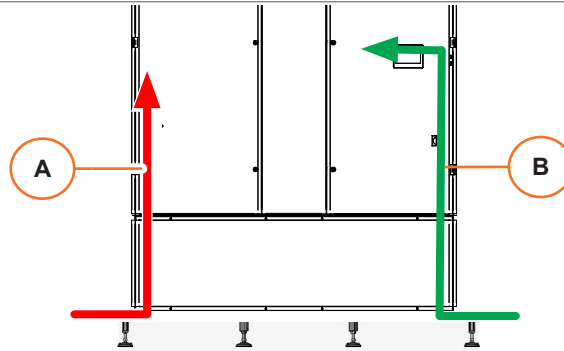

- Do not fit the supply cable in the raceways inside the electric panel. The electrical cables must pass through the unit shoulder; the power cable [A] on left and sensor/alarms cable [B] on the right.
- The connection for remote ON-OFF must be done by the installer.
- The general alarm terminals allow remote alarm signaling.
- In case of short circuit, check the sticking of the involved switch and replace it.
- The remote ON/OFF and the Fire Alarms Signal are connect directly to the unit.

Check integrity

- Make sure that all electrical connections are tight.
- Make sure that all electrical components are undamaged.

Hot surfaces

- The cables must not touch hot surfaces. If necessary, wrap the electrical cables by a thermal insulating sheath.

9.4 Piping Connections



WARNING

Only authorized personnel is allowed to perform operations on the piping.

9.4.1 General instructions

Connections

The inlet and outlet directions are clearly marked with labels and arrows on the respective pipings. Pay attention to follow the directions.

Keep clean

- Keep the piping clean and dry.
- Make sure that the surfaces to be brazed are clean and that the ends of the tubes have been carefully reamed to remove any burrs.
- Ensure that all loose material has been cleaned from inside the tubing before brazing.

Brazing

NOTE When copper is heated in the presence of air, copper oxide forms. POE oil will dissolve these oxides from inside the copper pipes and deposit them throughout the system, clogging filter driers and affecting other system components.

- Use copper piping with a brazing alloy with a minimum temperature of 732°C, such as Sil-Fos.
- Avoid soft solders such as 50/50 or 95/5.
- For copper-to-copper joints, the phosphorus in the Sil-Fos product serves as the fluxing agent and no separate flux by nitrogen is necessary to protect the brazing site. For brass application however, nitrogen flux is recommended.
- In any case, during brazing always use pure dry nitrogen through the piping with a flow of 0,5-1,5 l/s. This avoids the presence of oxygen on the heated surfaces.
- Do not overheat the piping (to minimize oxidation).

Piping layout

- Keep the piping as short as possible. This helps to minimize the pressure drops.
- Avoid bends as much as possible. Make bends with large radius (bending radius at least equal to the pipe diameter).
- For hard copper piping use preformed curves. You may bend soft copper piping by hand or by a bending tool.
- Support both the horizontal and the vertical piping by vibration dampening clamps that include rubber gaskets. Place the clamps every 1,5-2 m.

9.4.2 Chilled water

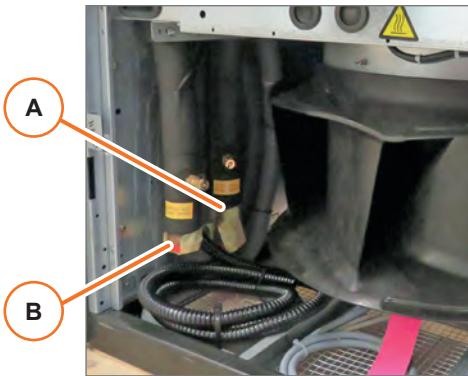

- Connect the chilled water inlet piping to the pipe [A].
- Connect the chilled water outlet piping to the pipe [B].
- ▶ If you use the grooved connections see 9.4.4 *Joining pipes with Grooved connections*.
- ▶ If you use the grooved connections, then you have the following options to create the connection:
 - Use the two smooth pipe sections that are provided with the units. Ready to connect by brazing.
 - See recommendation for brazing (par.9.4)
 - Insulate both tubes using insulation with closed cells (e.g. Armaflex)
 - Request to Vertiv™ two threaded pipe sections.
 - In case of threaded connections use hemp and paste to get a reliable pressure - tight joint.

9.4.3 Hot water (optional)

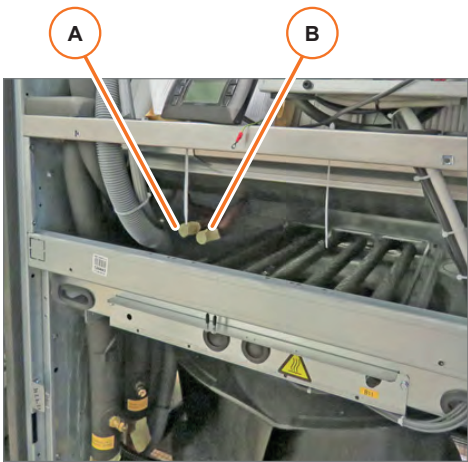

- Hot water reheat
- copper piping connection ready to connect by brazing
- see recommendation for brazing (par.9.4)
- Insulate both tubes using proper insulation

9.4.4 Joining pipes with grooved connections



Check the pipes ends

- Make sure that the outside surface between the groove and the end is smooth and clean.
- Remove any residual of oil, grease, dirt and particles.

Lubricate the gasket

- Apply a thin coat of grooved lubricant or silicone lubricant to the gasket lips and exterior.

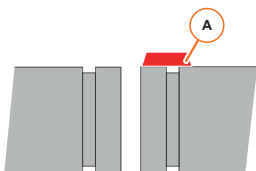

Insert the gasket

- Insert the gasket [A] over the end of one of the two pipes to be joined.
- Make sure that the gasket lip does not overhang the end of the copper pipe.

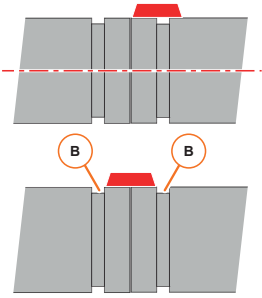

Join the ends

- Bring together the two pipe ends and align them.
- Slide the gasket into position, and make sure that it is centred between the grooves [B].



NOTICE Make sure that no portion of the gasket extends into the grooves.

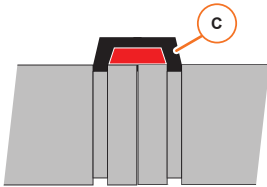

Join the pipes

- Insert the housing [C] over the gasket
- Screw the bolts [D] loosely, just enough to hold together the two parts of the housing.
- Make sure that the gasket is not rolled or pinched.
- Make sure the housing engages the grooves properly on both pipes.
- Tighten all nuts evenly by alternating sides until metal-to metal contact occurs at both bolt pads.

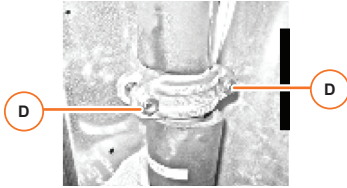

NOTE *Tightening the nuts evenly is important to prevent gasket pinching.*



NOTICE Leakage may occur if the gasket is pinched or damaged.



- Make sure the offsets are equal at the bolt pads. This is necessary to ensure a rigid joint.
- Visually inspect the bolt pads at each joint to ensure metal to-metal contact is achieved.



- Cover the Grooved connection with Armaflex insulation.

9.4.5 Condensate drain - without condensate pump

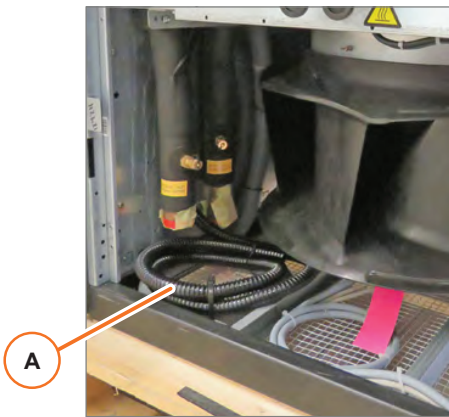

- Take the flexible pipe [A] coming out from the drain pan.

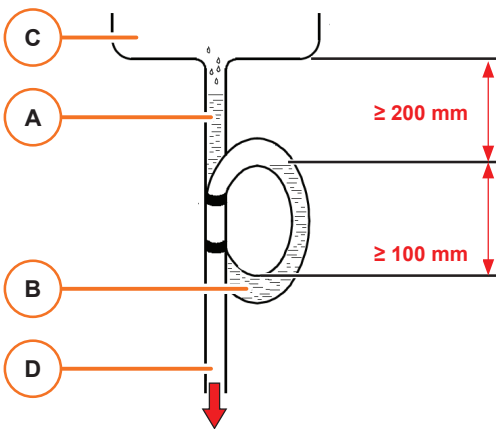

- Make a drain trap [B] on the pipe, placed at least 200 mm below the drain tray [C] and with a minimum height of 100 mm as shown in the figure.
- Connect the pipe outlet [D] to the on-site drainage system.
- In the Upflow configuration units the drain trap must be placed under the unit, in the raised floor.
- To avoid spraying the condensate, fill the drain trap with water before the start-up.



NOTICE If the drain trap is done inside the fan module in the Downflow units, then attach the tube and the drain trap properly to the fan module frame using cable ties/brackets, to avoid the risk of contact with fans.

9.4.6 Condensate drain - with condensate pump

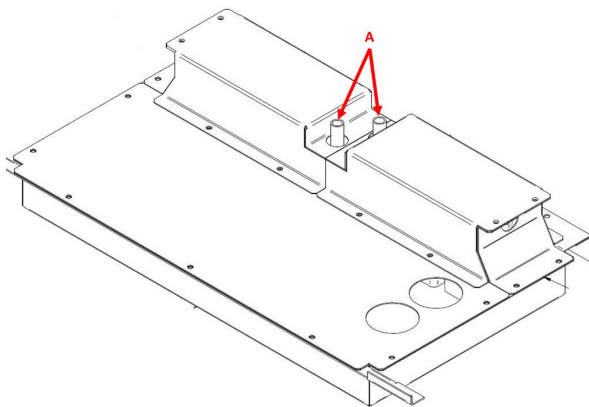

- Connect provided Ø10 mm hose to the discharge of each the condensate pump [A].

NOTE: Bend radius should not be more than 50 mm.

- Picture in the file 9.4.6 Condensate drain - with condensate pump.
- On the horizontal line - connect hose to provided adaptor and continue with Ø20 mm overflow pipe and fix with cable tie. Foto of the reduction and hose.

NOTE: Overflow pipe must be insulated and has to have gravity fall to termination.

Technical information about pump will be shipped with the unit.

Add image of reduction from file 9.4.6

Reduction can be connected to overflow pipe of diameter:

- Ø20 mm - 3/4";
- Ø24 mm - 1";
- Ø32 mm - 1" 1/4;
- Ø40 mm - 1" 1/2;

Condensation pump flow characteristics

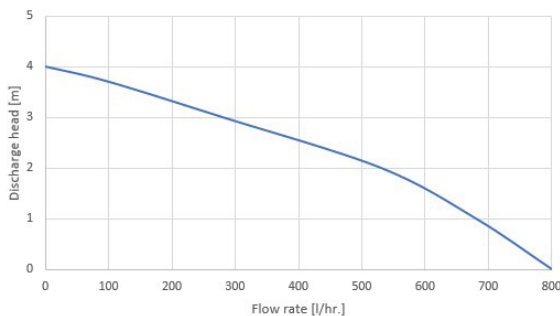

9.5 Electrical connections

9.5.1 Power supply cable

General instructions

- After opening the passage in the structural works (precut), for the supply line inlet, restore the original protection degree with suitable accessories for the wiring and junction boxes.
- Install the cable avoiding carefully to touch the hot parts.
- After having connected the cable, restore the protections against direct contacts.
- The system/line cable protection is to be arranged by the customer.
- Use a protection with differential switch.
- For details about the cable entrance holes see *Annex E - Connections*.

Standard power supply or dual power supply parallel

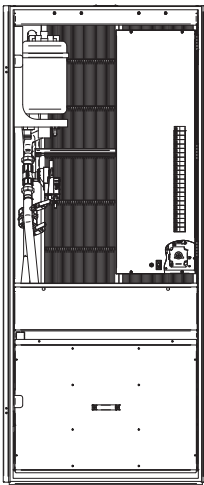

- Open the front door to get access to the electrical panel and to the internal safety panels.
- Remove the electrical panel cover by unscrewing the screws that hold it.
- Remove the internal safety panels by unscrewing the screws that hold each panel.
- Remove the frontal panels or frontal grids from the fan module.
- Run the power cable from the bottom through the precut in the fan module.
- Use appropriate cable ties to fix the cable to the frame on the left shoulder.

-
- Connect the power cable to the inlet terminals [C].

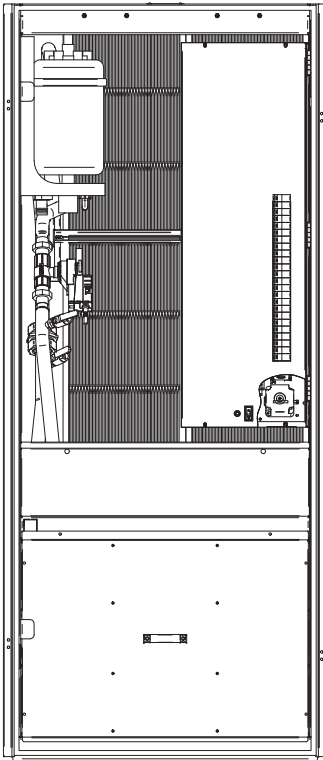

- Reposition all the panels removed for the cable connection:
 - the electrical panel cover
 - the fan electrical connection cover inside the fan module
 - the panels or grids removed from the fan module

Make sure not to damage the electrical cable between the panels and the unit.

If the unit is provided with ATS, then the procedure is the same as for standard power supply or dual power supply parallel, but there are two power cables (4 + 4 cords) to be connected to the inlet terminals of the ATS panel.

9.5.2 Contacts for the unit status signals

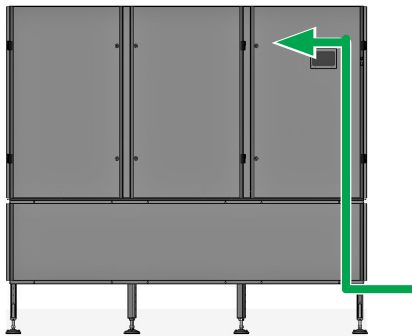

- Run the signal cable through the precut on the right shoulder of the frame.
- For details about the cable entrance holes see *Annex E - Connections*.
- Use appropriate cable ties to fix the cable to the frame on the left shoulder.
- Restore the original protection degree with suitable accessories for the wiring and junction boxes.

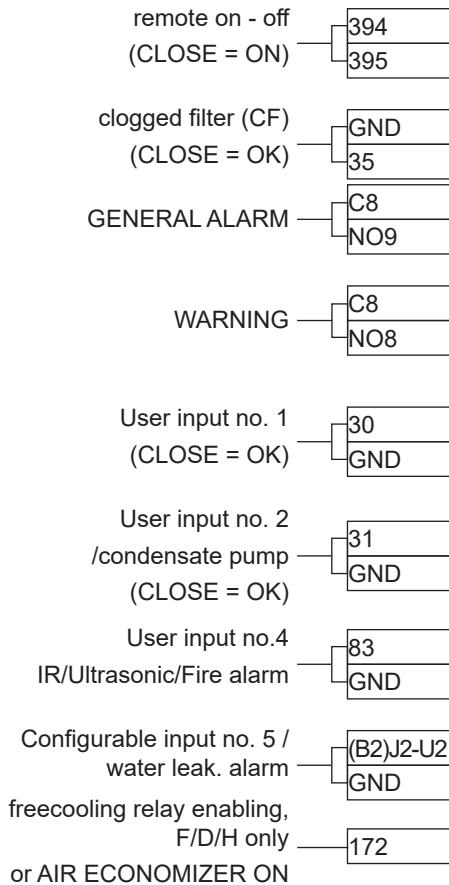

The dry contacts can be used only with PELV type sources, as described by the norm EN 60204-1 "Safety of machinery - Electrical equipment of machines".

The table on the left shows the available terminals and their meaning (refer to the Electric diagrams for details).

The cable must be protected by a sheath.

NOTES

*The C8-NO8 (warning) and C9-NO9 (alarm) terminals are on the control board.

The fans alarms are managed through Modbus.

The ID contacts are on the control board

9.5.3 Sensors connections

- Any remote or additional sensor must be connected to the unit via Modbus. See 9.6 Modbus Connections and Settings.

9.5.4 Supply air Temperature sensor

The supply temperature sensors should be installed in an area that is influenced only by the unit it is connected to. The supply sensor should be 1.5 - 4.5m from the cooling unit to provide an accurate reading for the control.

The sensor has been already installed in the unit and it's fixed in the fan module with at least 3m of cable length available. Remove the stripe and place it according the drawing.

NOTE: To grant a proper unit regulation, install the sensor according the drawing. Vertiv™ is not responsible in case of improper installation.

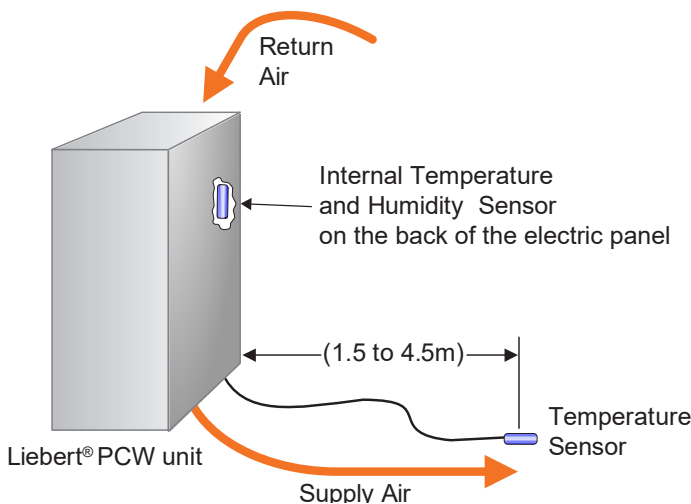

9.6 Modbus Connections and Settings

9.6.1 Connection of a device to the Modbus cable

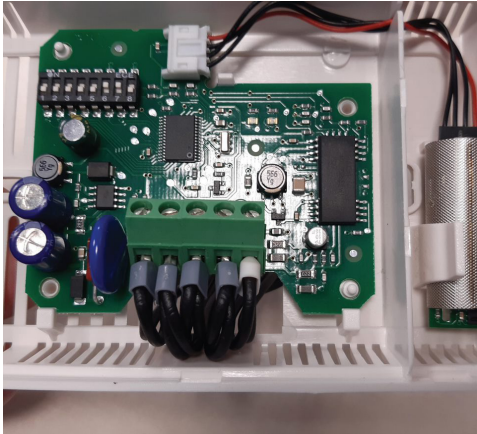

- Use a Modbus (RS485) cable, which is made of four shielded cables inside the sheath.
- Connect a positive and a negative wire to the inlet terminal.
- Connect a positive and a negative wire to the outlet terminal.

9.6.2 Setting of Modbus devices

The setting of a Modbus device requires the setting of the following parameters:

Dip switched address	Address of the device (unique)	<ul style="list-style-type: none"> • For T/H sensor: set the pins on its board.
		<ul style="list-style-type: none"> • For the fans (inside the unit): the setting is factory made. However you might need to do again the setting in case of fan replacement. Do the setting by the programming tool (see the <i>PDX-PCW Control Application</i>)
Baud rate = 19200 Parity = Even StopBits = 1	Same parameter for all the devices in the Modbus chain	

The following figures and table *Table 30 - Modbus options and addresses* provide the details and the addresses for the settings.

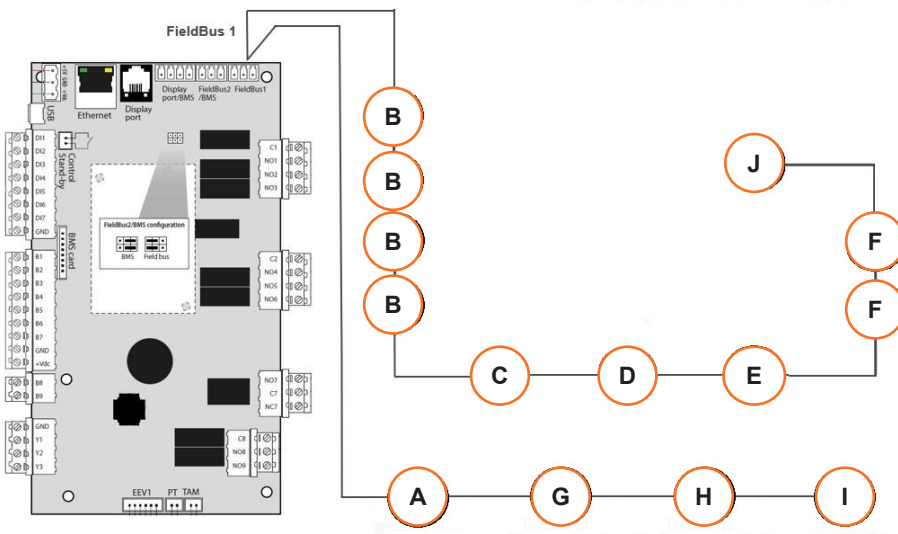

Table 30 - Modbus options and addresses

A	Return sensor T+H (up to 4)	F	Pressure Independent Control valve (up to 4)
B	EC fans (up to 6)	G	Air Economizer sensor T+H
C	Humidifier	H	Optional sensors T or T+H (up to 3)
D	Energy meter	I	Remote sensors T or T+H (up to 10)
E	Expansion board	J	Differential pressure transducer

NOTE: T - Temperature sensor
H - Humidity sensor

9.7 Filling the water system

NOTE The following instructions refer both to chilled water and to hot water. With the difference that hot water coil piping has to have drain valves supplied by the customer.

9.7.1 Water supply

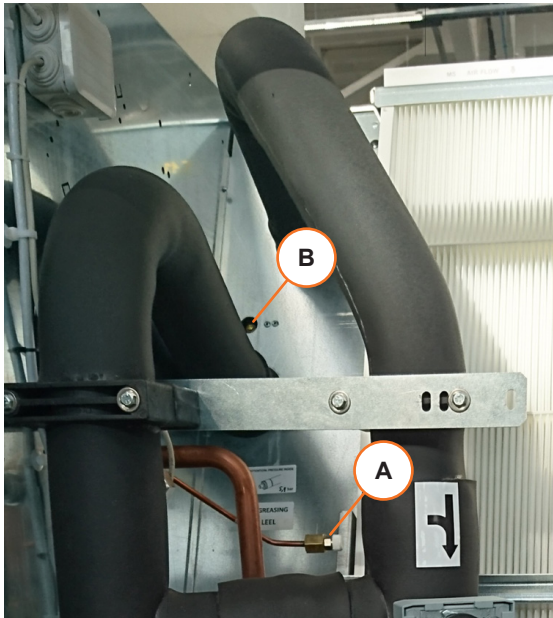

For each coil:

- Make sure that the drain valves [C], [C1], [C2] are closed.
- Open the vent valves [B] - chilled water coil, [A] - hot water reheat coil to deaerate the unit's coils and piping.
- If there are shut-off valves [D] on the water return (building facility), then make sure that they are open.
- Open the shut-off valves on the water supply system upstream the unit (building facility).
- Supply water through a filling group or from the plant
- Close the vent valves when only water and no air blows out of them.
- If necessary, fill-in or tip-up the ethylene glycol (see 9.7.2 Adding ethylene glycol).



NOTICE

Do not exceed the nominal operating pressure of the circuit components.

Air Bubbles on the circuit can cause a loss of precision in cooling action so de-aeration is recommended

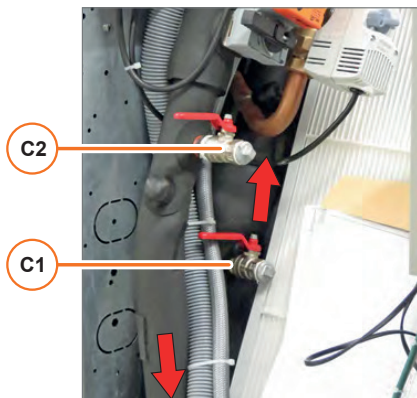
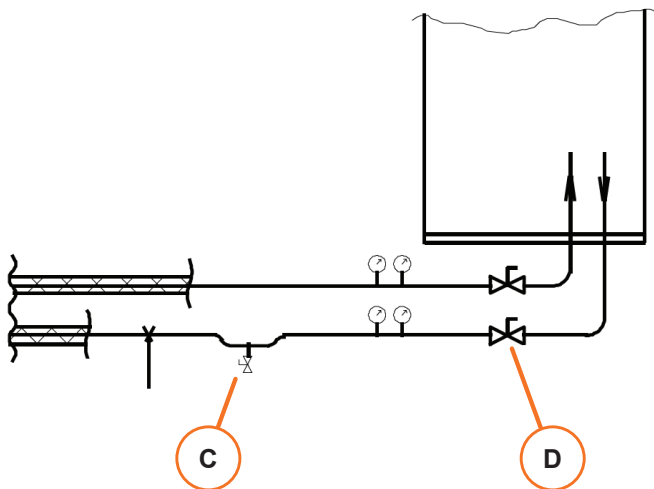

The unit is provided with the following drain valves:

- [C1] Drain valve on water inlet piping
- [C2] Drain valve on water outlet piping

9.7.2 Adding ethylene glycol

Prevent freezing If it is required to work with temperatures below 0°C, it is recommended to use glycol mixtures.

How much ethylene glycol to add Use the following table to calculate the percentage of ethylene glycol that must be added to the water:

Ethylene glycol [% in weight]	0	10	20	30	40	50
Freezing temperature, °C (*)	0	-4,4	-9,9	-16,6	-25,2	-37,2
Mixture density at 20°C (*) [kg/l]	---	1 017	1 033	1 049	1 064	1 080

(*) Values are for Clariant Antifrogen N. For different brands, check manufacturer's data.



NOTICE

Always charge the water system with the required glycol percentage necessary for the lowest water temperature at the installation site. Failing to comply with this instruction shall invalidate the unit warranty.

Procedure

- Fill the water system with water (see 9.7.1 *Water supply*).
- Disconnect the water system from the sanitary water supply, so to prevent any return of water mixed with ethylene glycol to the sanitary water supply.
- Add the ethylene glycol until up to the required percentage.
- To avoid stratification, run the circulation pump of the chilled water system (building facility) for a least 30 minutes after adding any glycol.

Checks

- After any topping-up of water check the concentration of the glycol if necessary.
- Check the head and the flow rate of the circulation pump (building facility) to be used, since the hydraulic features of the system changes by adding glycol (see 6.2.3 *Glycol mixture correction factors*).

9.8 Final Checks

NOTE

Follow these instructions at first startup and also in case of restart after a long stop.

NOTE

Record the functional data on the *Start-Up certificate*.

Electrical system



WARNING

Disconnect the power supply before doing the following checks on the electric system as explained in *1. Safety*.

- Check all the cable connections particularly the main power connections on the power fuses and contactors.
- Check that all thermal protections are calibrated according the electrical data tables reported on wiring diagram.
- Check the electrical absorption of all components.
- Check the tightening of all terminal block and screws

Tightness

After finishing all of the connections and installation operations, including mounting accessories (plenum, ducting) and floor elements (base frame), check all the unit edges and gaps and make sure that they comply with the protection degree IP2x specification (protection against finger access).

Cooling system

- Make sure that the condensate drain line is connected and not obstructed.
- Make sure that all the factory clamps that fix the piping to the structure have been reinstalled (if removed during the installation).

Air system

- Check that the unit fans are operating properly.
- Check all the unit options that involve the air flow management (such as air economizer, return dampers and smart aisle™) operate properly.
- Check that all the temperature and humidity probes read a correct value.
- Make sure that the humidifier supply and drain water connections are connected properly.
- Check that the humidifier works properly.
- Check that electrical heaters operate when required.

Safeguards

- Make sure that all the safeguards (panels, grids) have been mounted again.
- Close and lock all the doors.
- Place again all the floor panels around and under the unit.

Everything OK?

Start the normal operation: see *10. Operation*

10. Operation

Content of this chapter

10.1 Safety Instructions.....	83	10.5 Stop.....	85
10.2 Power-up.....	83	10.6 Restart.....	85
10.3 Start.....	84	10.7 Teamwork.....	85
10.4 Check the Operation.....	84		

10.1 Safety Instructions



WARNING

Improper operations can cause injury or death.



NOTICE

Improper operations can cause product damage.



Read carefully the chapter *1. Safety*.

Pay attention to the safety labels on the unit and to the safety warnings in this chapter.



NOTICE

The power supply should never be disconnected during normal operation, except when performing maintenance.

10.2 Power-up

Single power supply

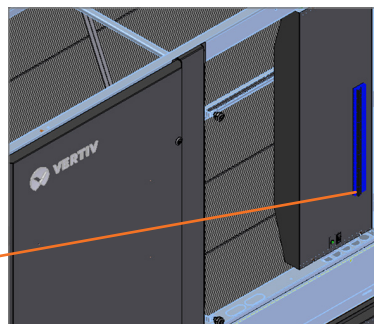

Main unit

1. Close the disconnection device upstream the unit (to be installed by the customer).
2. Close the disconnecting switch [A]

- If the display is present, then check that it switches **ON**.
- In case of first startup or after maintenance on the electric system, check again by a voltmeter or tester if the voltage and phase difference fall within the indicated limits.

10.3 Start

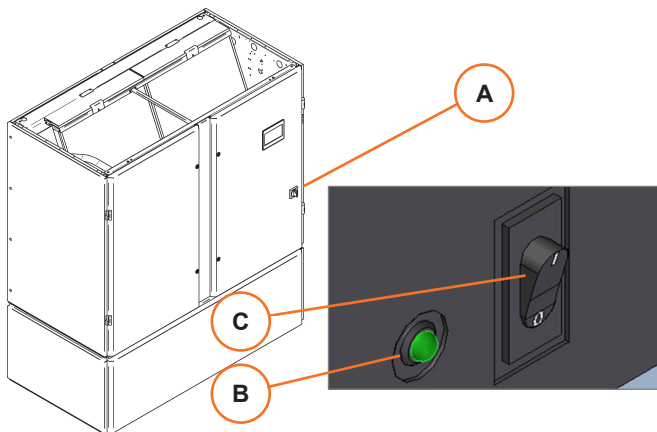

- Set the ON/OFF switch [A] to **ON**. (Main switch option on the picture). You must open left door to access main circuit breakers in standard solution.
- Adjust the setpoint as indicated in the *PDX-PCW Control Application*.

Set ON/OFF switch [C] for controls to **ON**.

The LED [B] lights up, showing the presence of the electric power.

See the *PDX-PCW Control Application* for details.

If the LED does not light up see *12. Troubleshooting*

NOTE

*The fan starts immediately (the fan always works when the unit is ON).
The heaters can start 10 seconds later.*

10.4 Check the Operation



NOTICE

The following checks must be done:

- at first startup
- in case of restart after a long stop
- at time intervals during the normal operation

Alarms

- Make sure that all the alarms due to protective devices interventions have been reset (see *PDX-PCW Control Application*)

Control and safety devices

- Check the correct operation of the control and safety devices.

10.5 Stop

Single power supply

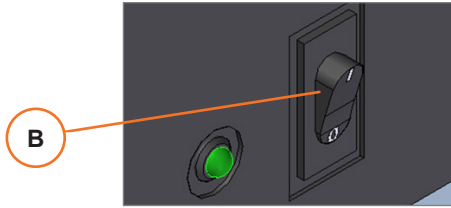

Dual power supply

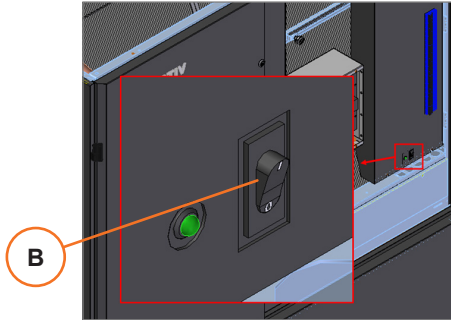

In case of a long stop (seasonal shutdown):

- Set the disconnecting switch [B] to the position “O”.
- Close the disconnection device upstream the unit.

10.6 Restart

After a short stop

The unit is still powered

- Set the ON/OFF switch to **ON**.

After a long stop

• Do the complete procedure as described in: *10.2 Power-up, 10.3 Start*

In case of power blackout

See *5.5.1 Standard or dual power supply*

10.7 Teamwork

The factory setting for the control system is the stand-alone mode.

If the unit is connected to other units in a network (by Ethernet), a master unit controls the switching ON/OFF of all of the units.

The base configuration for the Teamwork can be one of the following:

- Lead-Lag (standby + rotation + changeover on alarm)
- Cascade

See the *PDX-PCW Control Application* for more information and instructions about the Teamwork configuration.

Four ‘teamwork’ mode can be adopted:

- **No Teamwork** - The units work independently on the cooling control. Sensor values and setpoints are not shared;
- **Teamwork Mode 1 (Parallel)** - The control uses the system PI’s for driving cooling, heating, ventilation, humidification and dehumidification;
- **Teamwork Mode 2 (Independent)** - The control drives cooling, heating, ventilation, humidification and dehumidification based on local requests, while avoiding operational conflict with the other units in the network;
- **Teamwork Mode 3 (Smart Aisle™)**.

11. Maintenance

Content of this chapter

11.1 Safety Instructions.....	87	11.5 Replacement of Components.....	93
11.2 General Instructions.....	88	11.5.1 Replacing the control board.....	93
11.3 Maintenance Program.....	89	11.5.2 Replacing an air filter.....	93
11.3.1 Electrical and control system.....	89	11.5.3 Replacing a fan - general instructions.....	93
11.3.2 Cooling system.....	90	11.5.4 Replacing a fan - Upflow units.....	94
11.3.3 Air system.....	91	11.5.5 Replacing a fan - Downflow units.....	95
11.4 Draining the chilled water and hot water system.....	92	11.5.6 Replacing the valve actuator.....	96
11.4.1 Draining the chilled water.....	92	11.5.7 Replacing the condensate pump.....	97
		11.6 Calibrations.....	98

11.1 Safety Instructions



WARNING

Improper operations can cause injury or death.



NOTICE

Improper operations can cause product damage.

Check the unit regularly and solve the problems as they occur.

Lack of maintenance could reduce the performance or damage the unit.



NOTICE

All the tasks that are explained in this chapter must be carried out only by authorized and trained technicians. We recommend the Vertiv™ Customer Service.

For any operation that is not specifically mentioned in this manual you must contact Vertiv™ Technical Support.



Read carefully the chapter *1. Safety*.

Pay attention to the safety labels on the unit and to the safety warnings in this chapter.

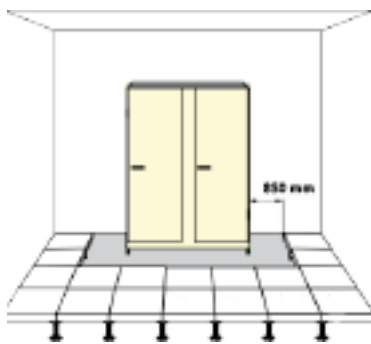

For Downflow units installed on a raised floor



WARNING

Rotating elements, hot surface elements

If you need to remove the floor tiles within a distance of 850 mm from the unit, first disconnect the unit from the power supply.

11.2 General Instructions

Warning labels

- Check regularly that the warning labels are still on the unit and that they are clearly visible.
- Replace any missing or damaged label.

See *Annex C - Safety Labels* for the mapping of the safety labels placed on the unit.

Spare parts

The use of original spare parts is recommended.

Using third-party material can invalidate the warranty.

When placing an order refer to the *Component List* enclosed with the unit and quote the unit model and serial number.



NOTICE

If you need to replace a component, then follow carefully the instructions of the manufacturer that come with the component.



NOTICE

If you need to weld a component, then be careful not to damage other components (like gaskets, seals, O-rings, ...)

Removing the upper panels

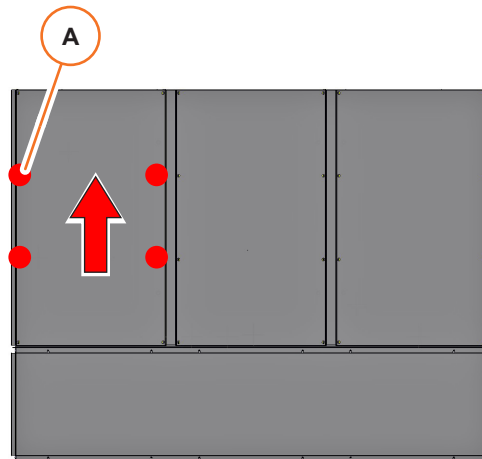

Rear view

- Loose the fixing screws [A].
- Lift the panel and release it from the hook on top.



CAUTION

The panels are heavy (up to 25 kg). This operation must be done by two maintenance operators.

11.3 Maintenance Program

NOTE If you encounter any problem, then see also 12. Troubleshooting.

11.3.1 Electrical and control system



WARNING

The unit contains potentially lethal voltage in some circuits. The electric and control panels can retain a stored high-voltage electrical charge for up to **10** minutes. Before working inside the electric and control panels proceed as follows:

- Open all the local and remote disconnecting switches of the unit.
- Wait at least **5** minutes.
- Verify with a voltmeter that the power is **OFF**.



NOTICE

Make reference to the *Electric Diagrams* provided with the unit.

Perform the periodic checks and maintenance operations as specified in the following table.

Component or function	Operation	Frequency [months]		
		3	6	12
Power consumption	Measure the power consumption of the connected devices. Do the measurements after the thermal magnetic circuit breakers. If a measured value is different from its nominal value, then check the power supply line and the cables. If you do not find any fault in the cables, then replace the device.		X	
Connections	Check if the connections are tight. Tighten any loose connection.		X	
Display (if present)	Check if there are faulty pixels or any malfunctioning		X	
Ultracap	Check that the ultracap feeds the control board at least for 30 seconds		X	
Controll battery	Check that the ultracap feeds the control board at least for 30 seconds		X	
Protective covers	Make sure that all the protective covers are in place and that they are not loose or damaged. Repair or replace if necessary.			X
Fuses	Check visually. Replace if necessary.			X

11.3.2 Water system



WARNING

The unit contains potentially lethal voltage in some circuits.

The electric and control panels can retain a stored high-voltage electrical charge for up to **10** minutes.

Before working inside the electric and control panels proceed as follows:

- Open all the local and remote disconnecting switches of the unit.
- Wait at least **5** minutes.
- Verify with a voltmeter that the power is **OFF**.

Perform the periodic checks and maintenance operations as specified in the following table.

Component or function	Operation	Frequency [months]		
		3	6	12
Piping and connections	<ul style="list-style-type: none"> - Make sure there is no loss of water. - Check that the water supply is ensured. 		X	
Trapped air	<ul style="list-style-type: none"> - Remove any air from the water system using the vent valve on the top left - hand side of each coil. 		X	
Ethylene glycol	Check the level Top up if necessary (see <i>9.7.5 Filling the water system</i>).		X	
Operation	Check that the water circulation is in perfect order. Check that the water valve operates correctly. Check the temperature and the pressure of the water on the inlet and outlet side using thermometers and manometers, if installed.		X	

11.3.3 Air system



WARNING

This unit operates and restarts automatically.

The fan blades can automatically start rotating without warning at any time during a cooling cycle or after the power is restored after a power failure.

The fans may suddenly start blowing out a strong air flow, which may carry particles and small objects from inside the unit.

Before working inside the unit cabinet, removing the fan guards or servicing the fans (speed control, blades, motors) proceed as follows:

- Turn all the disconnecting switches to **OFF**.

Perform the periodic checks and maintenance operations as specified in the following tables.

Component or function	Operation	Frequency [months]		
		3	6	12
Fans	The fans operate as required?	X		
Fans	Visual inspection for dirtiness, damage, corrosion Clean if necessary	X (*)		
Fans	Any abnormal vibration? Then tighten the fixing to the supporting structure	X		
Fans	Any abnormal sound? Then check the bearings	X		
Fans	Measure the power consumption.		X	
Filters	Visual inspection for dirtiness, damage, corrosion Clean or replace if necessary (see <i>11.5.2 Replacing an air filter</i>)	X (*)		
Filter clog sensor	The sensor operates as required?		X	
Fresh air intake Economizer (if present)	The accessory operates as required?		X	
Humidity and temperature sensor	See <i>11.6 Calibrations</i>		X	
Heaters (optional)	The accessory operates as required?		X	
Temperature safety switch	See <i>11.6 Calibrations</i>		X	
Condensate tank (optional)	Visual inspection for dirtiness, damage, corrosion Clean if necessary.	X		
Humidifier	See the related annex.			

(*) Check more frequently in dusty environment.

11.4 Draining the chilled water and hot water system

11.4.1 Draining the chilled water + Draining hot water system

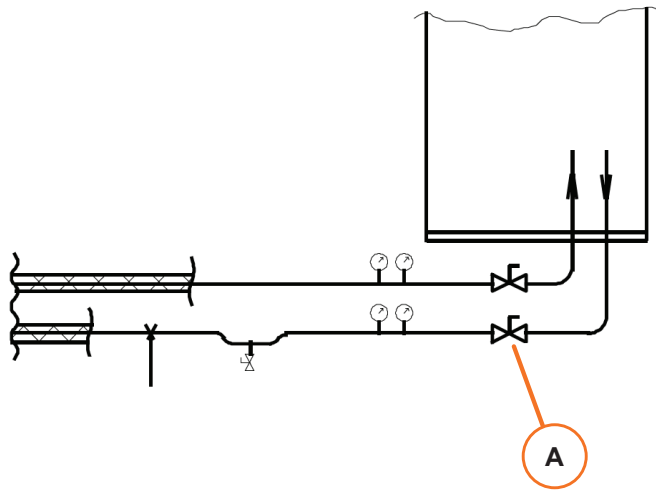

For each coil:

- Close the shut-OFF valves on the water supply system upstream the unit [A] (building facility).
- Open the drain valves [B].
- Open the vent valves [C] .
- Let the drain valves [B] open until no more water flows out of them

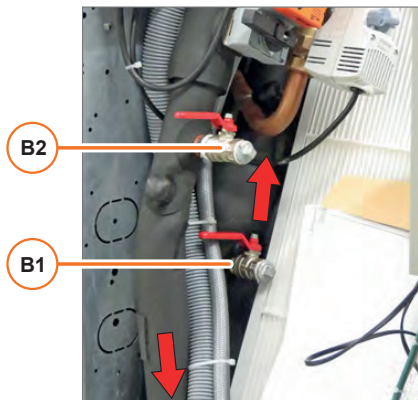

The unit is provided with the following drain valves:

- [B1] Drain valve on water inlet piping
- [B2] Drain valve on water outlet piping

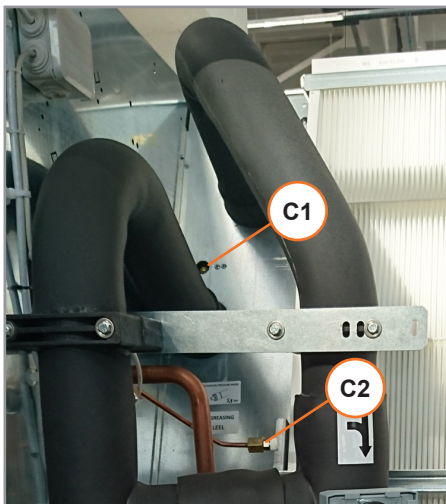

Vent valves location:

- [C1] Vent valve on chilled water coil
- [C2] Vent valve on hot water re-heat coil (optional)

11.5 Replacement of components

11.5.1 Replacing the control board

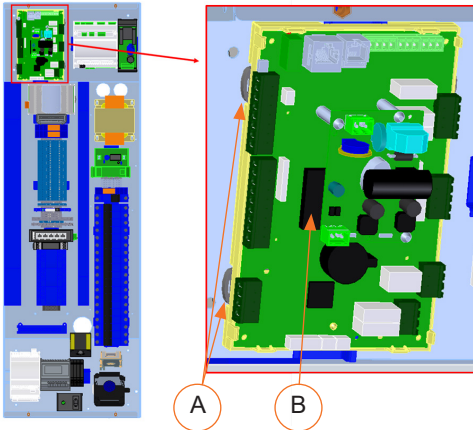

WARNING

Disconnect the unit from the power supply.

How to remove

- Remove the cover plate of electrical and control panel.
- Remove all the cables connected to the control board.
- Insert a screw driver in one of the eyes [A] and lever out the control board [B].
- Repeat for the other eye(s) until the control board is released.

How to reassemble

- Press the control board in the DIN rail until it locks.
- Connect again the cables.
- Reassemble the cover plate of electrical and control panel.
- Connect the unit from the power supply.
- Upload the software from the computer (or USB drive) to the control board.
- Restart the unit.

NOTE: Battery type - Lithium button (removable), BR2032, 3Vdc
Duration min. 8 years in normal operating conditions

11.5.2 Replacing an air filter

- Switch off the unit and open the front panel by the key.
- Unscrew and remove the filter brackets [A].
- Remove the air filters [B]

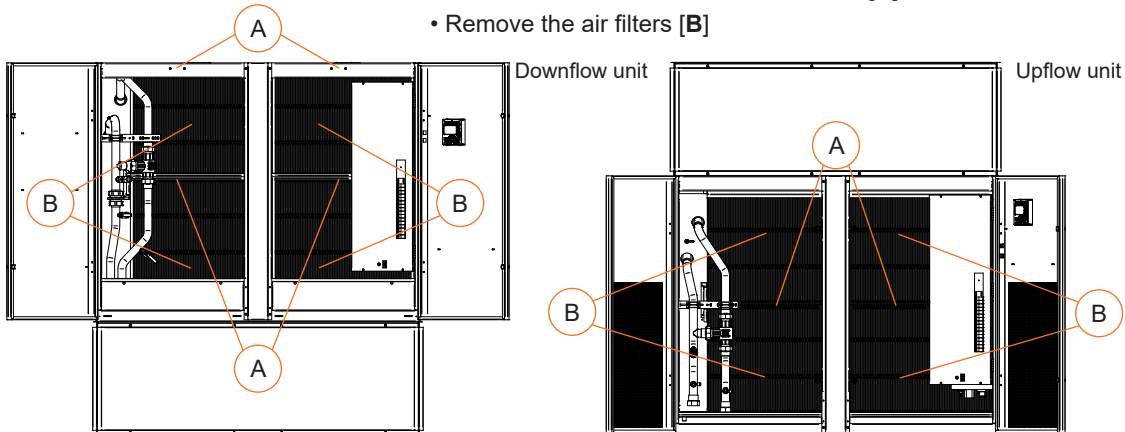

11.5.3 Replacing a fan - general instructions

Safety



WARNING

Disconnect the unit from the power supply.



CAUTION

The fans and the panel are heavy.

This operation must be done by two maintenance operators.
Use adequate lifting equipment and follow the fan manufacturer instructions for handling

Additional information

Make reference to the fan manufacturer instructions for transport, handling and mounting the fans.

Modbus address

- After reassembling, connect the fan to a laptop and use the configuration software provided by the manufacturer to set the fan Modbus address (see 9.6.2 *Setting of Modbus devices* and the *PDX-PCW Control Application* for details).

11.5.4 Replacing a fan - Upflow units

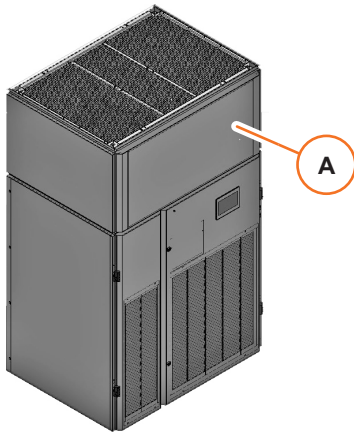

- Remove the panel [A].
- Disconnect the fan electrical cable from the connector.

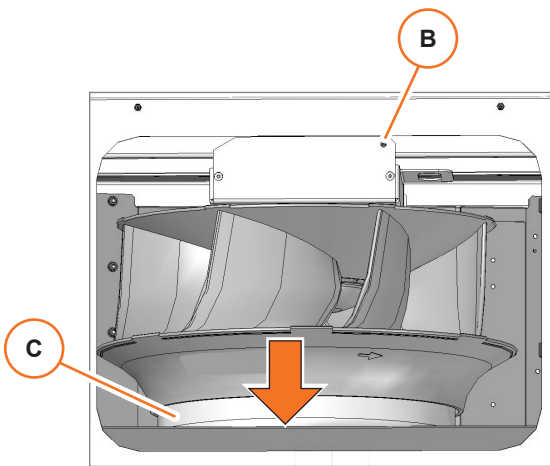

- Remove the screw [B] and slowly put down the fan on its inlet collar [C].

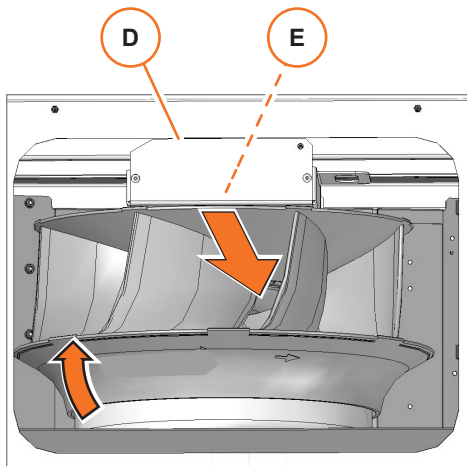

- Remove the screw [D].
- Lift the fan higher than its inlet collar.
- Pull the handle [E] to slide the fan out of the bay

- Proceed in reverse order to reassemble the fan.

11.5.5 Replacing a fan - Downflow units

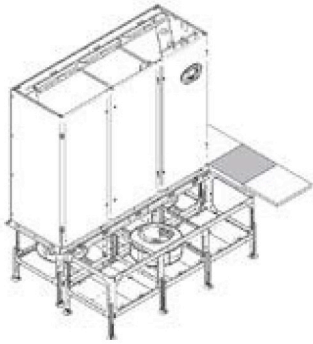

- Remove a few floor tiles in front of the fan section.
- Remove any obstacle in front of the fans to allow the fan extraction (raised floor structure, piping, ...).

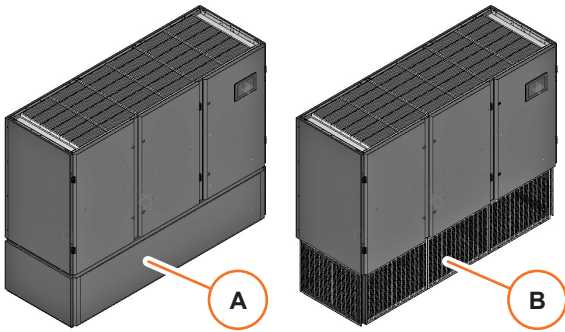

- Remove the panel [A] or the grid [B].

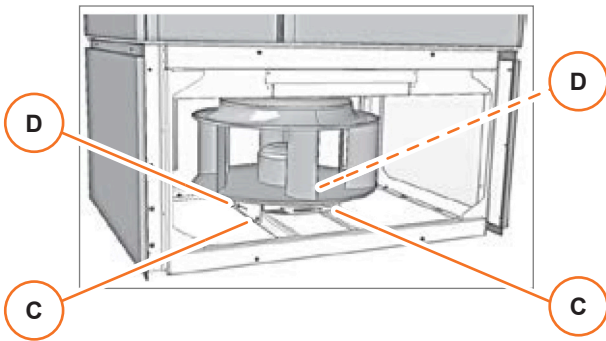

- Disconnect the fan electrical cable from the connector.
- Remove the two front screws [C] that fix the fan support to the sliding bars.
- Loosen the two back screws [D] that fix the fan support to the sliding bars.

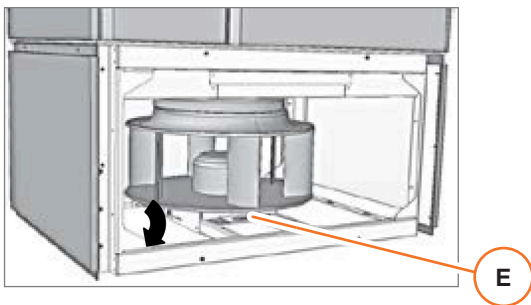

- Slide down the fan by pulling the handle [E].
- Remove completely the two screws [D] on the back of the fan.
- Pull the handle to slide the fan out of the bay

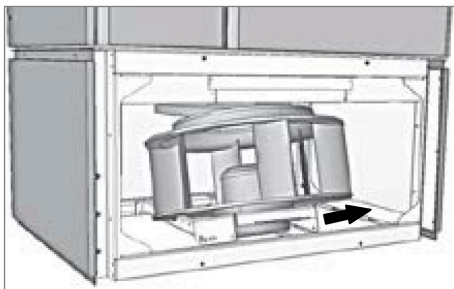

- Proceed in reverse order to reassemble the fan.

11.5.6 Replacing the valve actuator - 2/3 way valves PIC valves (optional)

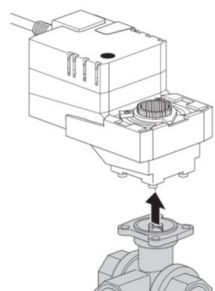
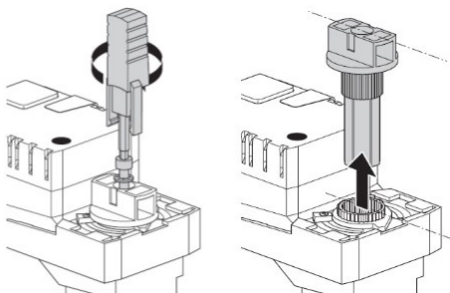
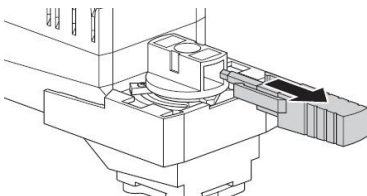
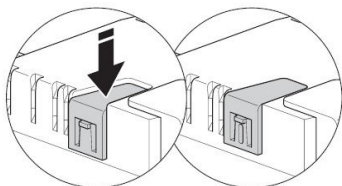
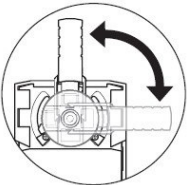
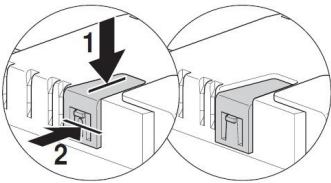
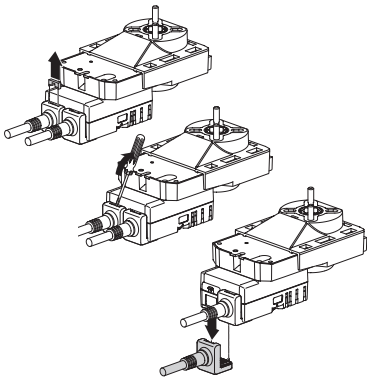

1) Turn **OFF** the unit – set the disconnection switch of the unit to position “0” (see chapter 10.5 Stop)

2) Disconnect the wires from electric panel (from power and control terminals) (see wiring diagram attached to the unit for specific terminals)

In case of PIC valve: follow procedure on the first picture to disconnect cables from actuator.

- Remove two pins from actuator’s connectors with small straight screwdriver.
- Disconnect connector from actuator (see the picture beside).

3) Set the actuator / valve into default position:

- Press the disconnect button down (1) and hold it in position by pressing the latch (2)

- Manually turn the valve using the actuator handle until you reach the end stop

- Press the disconnect button again to release it

4) Pull the handle out. Notice the handle is equipped with hex/ Allen key

5) Hold the actuator and use this key to remove (rotate counter-clockwise) the bolt. Pull the spindle out

6) Now you can safely remove the actuator.

7) To install new actuator it is necessary to set ring to end stop. Then proceed with steps 6 – 1 in this order.

11.5.7 Replacing the condensate pump

Upflow unit

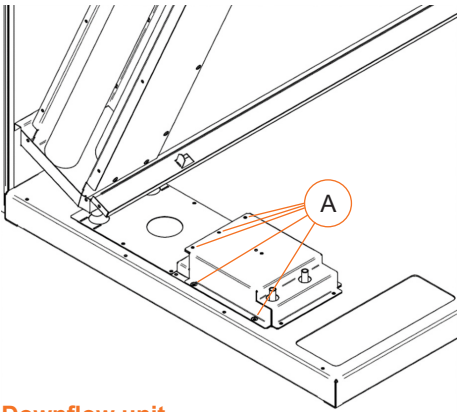

- Open the disconnecting switch for condensing pump
- Unscrew six self-drilling screws $\varnothing 4.8 \times 16$ mm screws [A]. for each pump,

Downflow unit

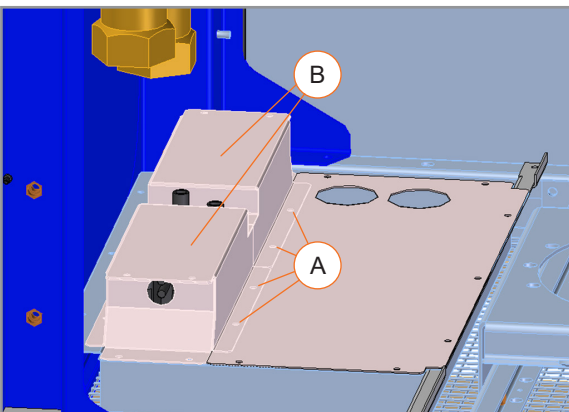

- Remove covers [B]

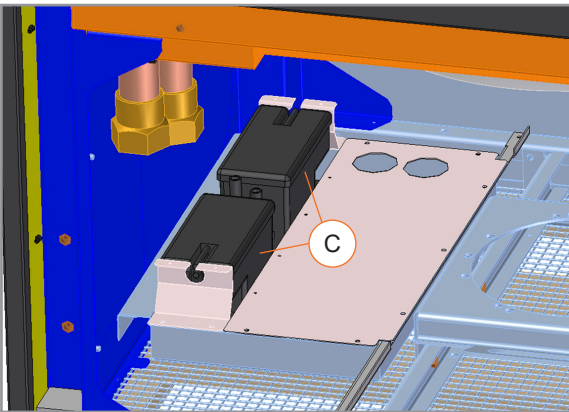

- Replace the pumps [C].

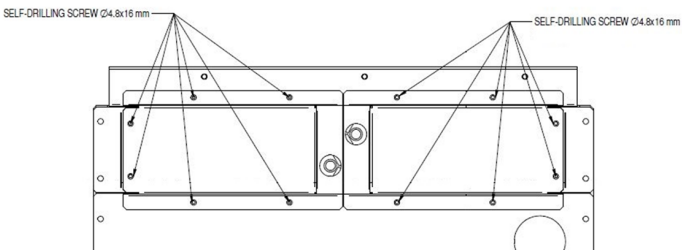

11.6 Calibrations



ENVIRONMENT

A misuse or an incorrect calibration of the unit leads to increased energy consumption, resulting in an economic and environmental damage.

- For control system calibrations refer to *PDX-PCW Control Application*

Clogged filter differential pressure switch

Adjustment range: 0,5 – 4 mbar
 Setting: 3 mbar (300 Pa)

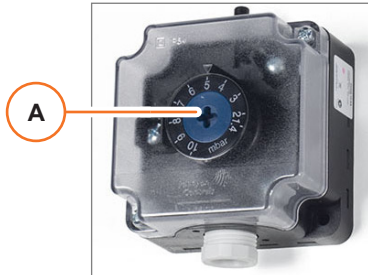

In case of replacement of the clogged filter differential pressure switch, then turn the screw [A] to adjust the setting.

Temperature safety switch (if heating is present)

Setting: 120°C ± 6°C
 Manual reset

12. Troubleshooting

Symptom	Possible Cause	Check or Remedy
The unit does not start	No power supply to the unit	Check voltage at input terminal block
	The circuit breaker or fuse for low-voltage transformer in unit is tripped	Locate the problem in the unit electrical panel and repair
	Remote ON/OFF	Check the remote switch
	The local control switch is opened	Check the local switch (green = ON)
High vibration on the unit	The piping are not properly fixed	Check the piping
A Modbus component is not read	Wrong Modbus cabling	Check the cabling
	The address name is not correct	Check the address
The fans do not run	The power cables are not connected	Connect the cables
	There is no signal	Check the Modbus chain
The unit is noisy	The fan is noisy	Check the fan fixing

13. Dismantling the Unit

The unit has been designed and built to ensure continuous operation.
 The working life of some of the main components, such as the fans, depends on the maintenance that they receive.
 The unit must be dismantled if it is moved to another site, or at the end of its technical and operational life.

13.1 Safety Instructions



WARNING
 Improper operations can cause injury or death.



Read carefully the chapter *1. Safety*.
 Pay attention to the safety labels on the unit and to the safety warnings in this chapter.



ENVIRONMENT
 The unit contains substances and components hazardous for the environment (electronic components).
 At the end of the useful life, when the unit is dismantled, the operation must be carried out by specialized technicians.
 The unit must be delivered to suitable centers specialized for the collection and disposal of equipment containing hazardous substances.
 The components must be recovered according to the laws in force at the installation site.

13.2 Operations

Operation	Notes
1. Disconnect the disconnecting switch from the electric power supply	Reverse the procedure from chapter 9. <i>Installation: 9.5.1 Power supply cable</i>
2. Drain the water	See <i>14.4 Draining the water system</i>
3. Cut the piping at inlet and outlet of the unit	
4. Remove the unit	Reverse the procedure from chapter 8. <i>Assembly and Positioning</i>
5. Move away the unit	See <i>7. Handling</i>
6. If you need to keep the unit in a storehouse for reuse	See <i>3.6.1 Storage conditions</i>
7. If you need to scrap the unit	Handle to authorized disposal company according to the local regulations about waste disposal.

Annex A - Chilled water circuit and hot water reheating coil

Content

1 - Single chilled water circuit and hot water reheating coil (optional).....	104
2 - Single chilled water circuit and hot water reheating coil (optional).....	105
3 - Dual chilled water circuit and hot water reheating coil (optional).....	106

1 - Single chilled water circuit and hot water reheating coil (optional)

Single chilled water circuit

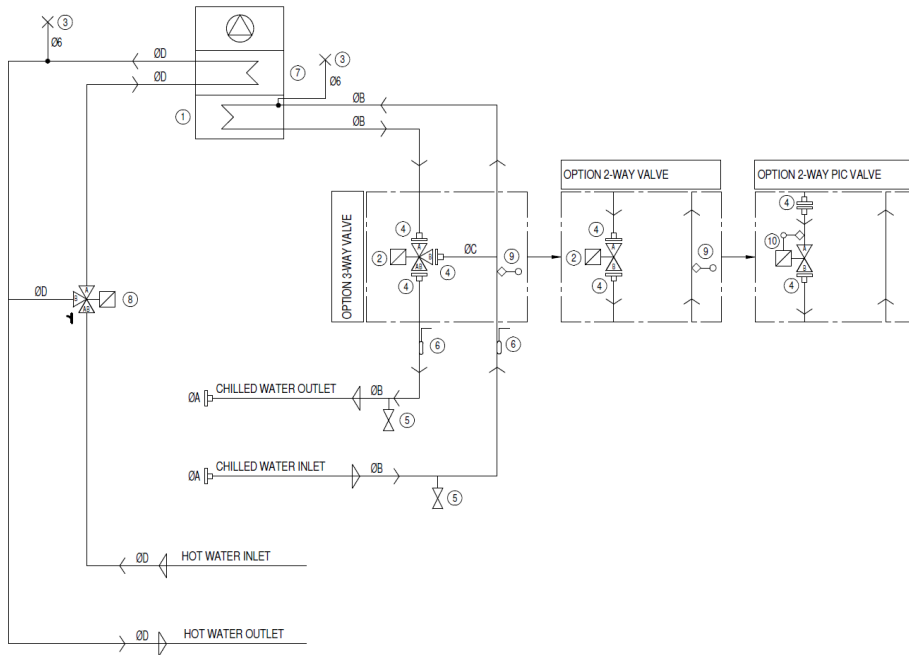

Ref.	Description
1	Chilled water cooling coil
2	Water valve
3	Manual air bleeding valve
4	Valve fittings
5	Drain valve
6	Water temperature sensor (opt.)
7	Reheating coil (opt.)
8	ON/OFF 3-way valve (opt.)
9	Flow transmitter (opt.)
10	PICV valve

NOTE:

Flow meter is installed on inlet pipe before T connection on straight pipe part

Unit name	Unit type	2-way valve		3-way valve		PICV		ØA	ØB	ØC	ØD
		DN	qty.	DN	qty.	DN	qty.				
PW025	Standard height	25	1	25	1	32	1	Rp 1 1/4"	35	35	22
PW030	Standard height	25	1	25	1	32	1	Rp 1 1/4"	35	35	22
PW035	Standard height	32	1	32	1	40	1	Rp 1 1/4"	42	42	22
PW040	Standard height	32	1	32	1	40	1	Rp 1 1/4"	42	42	22
PW046	Extended height	32	1	32	1	40	1	Rp 1 1/4"	42	42	22
PW045	Standard height	40	1	40	1	50	1	Rp 1 1/2"	42	42	22
PW060	Standard height	40	1	40	1	50	1	Rp 1 1/2"	42	42	22
PW066	Extended height	40	1	40	1	50	1	Rp 1 1/2"	42	42	22
PW070	Standard height	50	1	50	1	50	1	54	54	54	22
PW080	Standard height	50	1	50	1	50	1	54	54	54	22
PW091	Extended height	50	1	50	1	50	1	54	54	54	22

2 - Single chilled water circuit and hot water reheating coil (optional)

Single chilled water circuit

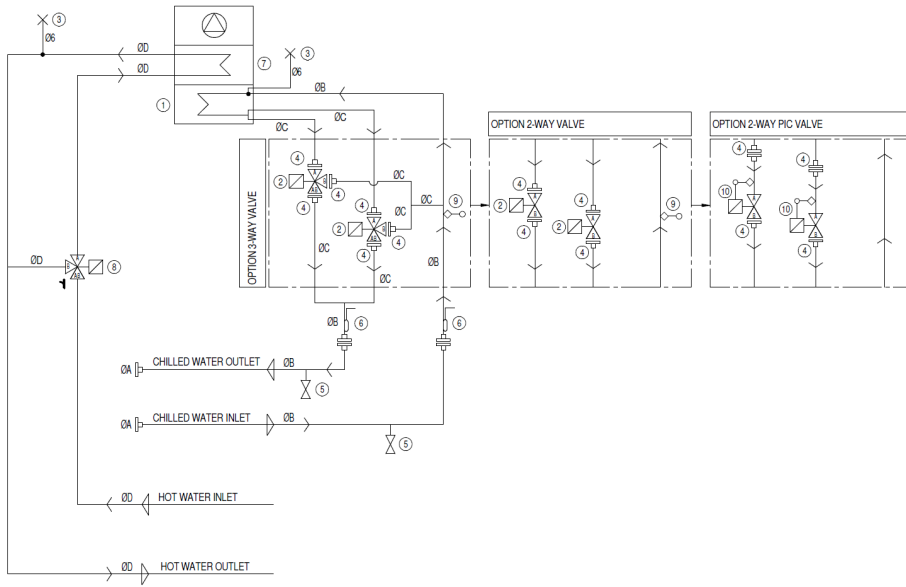

Ref.	Description
1	Chilled water cooling coil
2	Water valve
3	Manual air bleeding valve
4	Valve fittings
5	Drain valve
6	Water temperature sensor (opt.)
7	Reheating coil (opt.)
8	ON/OFF 3-way valve (opt.)
9	Flow transmitter (opt.)
10	PIC valve

NOTE:

Flow meter is installed on inlet pipe before T connection on straight pipe part

Unit name	Unit type	2-way valve		3-way valve		PICV		ØA	ØB	ØC	ØD
		DN	qty.	DN	qty.	DN	qty.				
PW095	Standard height	50	1	50	1	50	2	64	64	54	22
PW110	Standard height	50	1	50	1	50	2	64	64	54	22
PW136	Extended height	50	1	50	1	50	2	64	64	54	22
PW145	Standard height	50	1	50	1	50	2	64	64	54	22
PW161	Extended height	50	1	50	1	50	2	64	64	54	22
PW170	Standard height	50	1	50	1	50	2	64	64	54	22
PW201	Extended height	50	2	50	2	50	2	64	64	54	22

3 - Dual chilled water circuit and hot water reheating coil (optional)

Single chilled water circuit

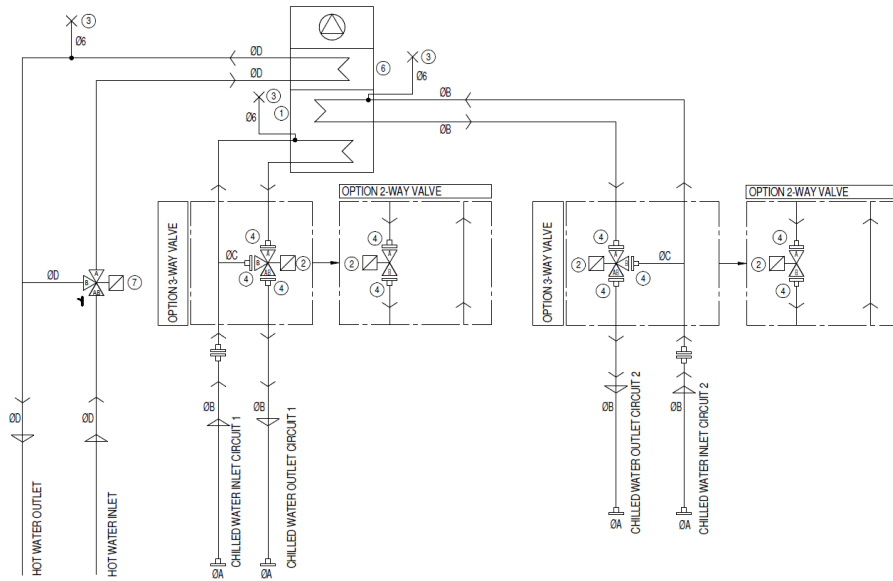

Ref.	Description
1	Chilled water cooling coil
2	Water valve
3	Manual air bleeding valve
4	Valve fittings
5	Drain valve
6	Water temperature sensor (opt.)
7	Reheating coil (opt.)
8	ON/OFF 3-way valve (opt.)
9	Flow transmitter (opt.)

NOTE:

Flow meter is installed on inlet pipe before T connection on straight pipe part

Unit name	Unit type	2-way valve		3-way valve		ØA	ØB	ØC	ØD
		DN	qty.	DN	qty.				
PW040	Standard height	32	1 + 1	32	1 + 1	Rp 1 1/4"	42	35	22
PW046	Extended height	32	1 + 1	32	1 + 1	Rp 1 1/4"	42	35	22
PW060	Standard height	40	1 + 1	40	1 + 1	RP 1 1/2"	42	42	22
PW066	Extended height	40	1 + 1	40	1 + 1	Rp 1 1/2"	42	42	22
PW080	Standard height	40	1 + 1	40	1 + 1	Rp 1 1/2"	42	42	22
PW091	Extended height	40	1 + 1	40	1 + 1	Rp 1 1/2"	42	42	22
PW110	Standard height	50	1 + 1	50	1 + 1	54	64	54	22
PW136	Extended height	50	1 + 1	50	1 + 1	54	64	54	22
PW145	Standard height	50	1 + 1	50	1 + 1	54	64	54	22
PW161	Extended height	50	1 + 1	50	1 + 1	54	64	54	22
PW170	Standard height	50	1 + 1	50	1 + 1	54	64	54	22
PW201	Extended height	50	1 + 1	50	1 + 1	54	64	54	22

Annex B - Safety Labels

Content

1 - Labels list.....	107
2 - Labels position.....	109



WARNING

Do not remove or cover the labels placed on the unit by the manufacturer.
 Check regularly that the warning label are still on the unit and that they are clearly visible.
 Replace any missing or damaged label.

1 - Labels list

Identification	Description
----------------	-------------

A

WARNING: DISCONNECT MAINS ISOLATOR BEHIND THIS COVER BEFORE ACCESSING OTHER COMPARTMENTS

ATTENZIONE: PRIMA DI ACCEDERE ALLE PARTI INTERNE DELLA MACCHINA, APRIRE IL SEZIONATORE ELETTRICO GENERALE CHE TROVERETE RIMUOVENDO QUESTO PANNELLO.

ACHTUNG: VOR WARTUNGSEINGRIFFEN DAS GERAT SPANNUNGSFREI MACHEN. HAUPTSCHALTER HINTER DIESEM PANEEL.

ATTENTION: AVANT D'ACCEDER AUX COMPOSANTS INTERNES AU CLIMATISEUR, ACTIONNER LE SECTIONNEUR GENERAL SITUE DERRIERE CE PANNEAU.

ATENCION: ANTES DE ACCEDER A LA PARTE INTERIOR DE LA MAQUINA, ABRIR EL INTERRUPTOR ELETTRICO GENERAL, PARA PODER GUITAR EL PANEL PROTECTOR.

ΠΡΟΣΟΧΗ: ΑΠΟΣΥΝΔΕΣΑΤΕ ΤΟΝ ΓΕΝΙΚΟ ΔΙΑΚΟΠΤΗ ΠΙΣΩ ΑΠΟ ΑΥΤΟ ΤΟ ΚΑΛΥΜΑ ΠΡΟ ΤΗΣ ΒΠΙΒΚΕΚΒΨΩΣ ΑΛΛΩΝ ΤΜΗΜΑΤΩΝ.

B

WARNING: HOT AND MOVING PARTS ENCLOSED, DISCONNECT THE MAINS SUPPLY BEFORE REMOVING THIS COVER.

ATTENZIONE: PARTI IN MOVIMENTO, CORPI CALDI, APRIRE IL SEZIONATORE ELETTRICO GENERALE PRIMA DI RIMUOVERE QUESTO PANNELLO.

ACHTUNG: DREHENDE UND ERHITZTE TEILE, VOR OFFNEN DIESES PANEELS DAS GERAT SPANNUNGSFREI MACHEN.

ATTENTION: PIÈCES EN MOUVEMENT: ELEMENTS CHAUFFANTS. ACTIONNER LE SECTIONNEUR GENERAL AVANT DE DEMONTER CE PANNEAU.

ATENCION: PARTES EN MOVIMENTO, CUERPOS CALIENTES, ABRIR EL INTERRUPTOR ELETTRICO GENERAL ANTES DE GUITAR EL PANEL PROTECTOR.

ΠΡΟΣΟΧΗ: ΠΕΡΙΚΛΥΕΙ ΘΕΡΜΑ ΚΑΙ ΚΙΝΟΥΜΕΝΑ ΜΕΡΗ. ΑΠΟΣΥΝΔΕΣΑΤΕ ΤΟΝ ΓΕΝΙΚΟ ΔΙΑΚΟΠΤΗ ΠΡΙΝ ΑΝΟΙΞΕΤΕ ΑΥΤΟ ΤΟ ΚΑΛΥΜΑ.

Identification	Description
----------------	-------------

C



D



E





DANGER - ROTATING BLADES
 DISCONNECT THE ELECTRIC POWER SUPPLY TO THE UNIT AND ASSURE THAT ALL FANS HAVE STOPPED ROTATING BEFORE OPENING FAN PANEL

PERICOLO - PALE ROTANTI
 SPEGNERE L'ALIMENTAZIONE ALLA MACCHINA E ASSICURARSI CHE TUTTE LE PALE SIANO FERME PRIMA DI APRIRE LA PORTA DEI VENTILATORI

GEFAHR - DREHENDE TEILE
 MACHEN SIE DIE ANLAGE STROMLOS UND VERSICHERN SIE SICH DASS ALLE DREHENDEN TEILE (VENTILATORBLÄTTER) ZUM STILLSTANDGEKOMMEN SIND BEVOR SIE DAS VENTILATORGEHÄUSE ÖFFNEN

DANGER - PALES TOURNANTES
 ETEINDRE L'ALIMENTATION ELECTRIQUE DE L'UNITE ET S'ASSURER DE L'ARRET DES PALES AVANT D'OUVRIER LE PANNEAU DES VENTILATEURS

F

	<p>SWITCH-OFF MAIN SWITCH BEFORE DISMOUNTING EL. PANEL COVER</p>	<p>WARNING! BEFORE WORKING ON THE DEVICE DISCONNECT ALL POWER SOURCES AND CHECK HAZARDOUS VOLTAGE BETWEEN ALL TERMINALS INCLUDING THE PROTECTIVE EARTH!</p> <p style="text-align: center;">  THE DEVICE HAS OTHER POWER SOURCES </p>
	<p>MAIN SWITCH</p>	<p>WARNING! ATS LIVE EVEN THE MAIN SWITCH-OFF</p>

2 - Labels position

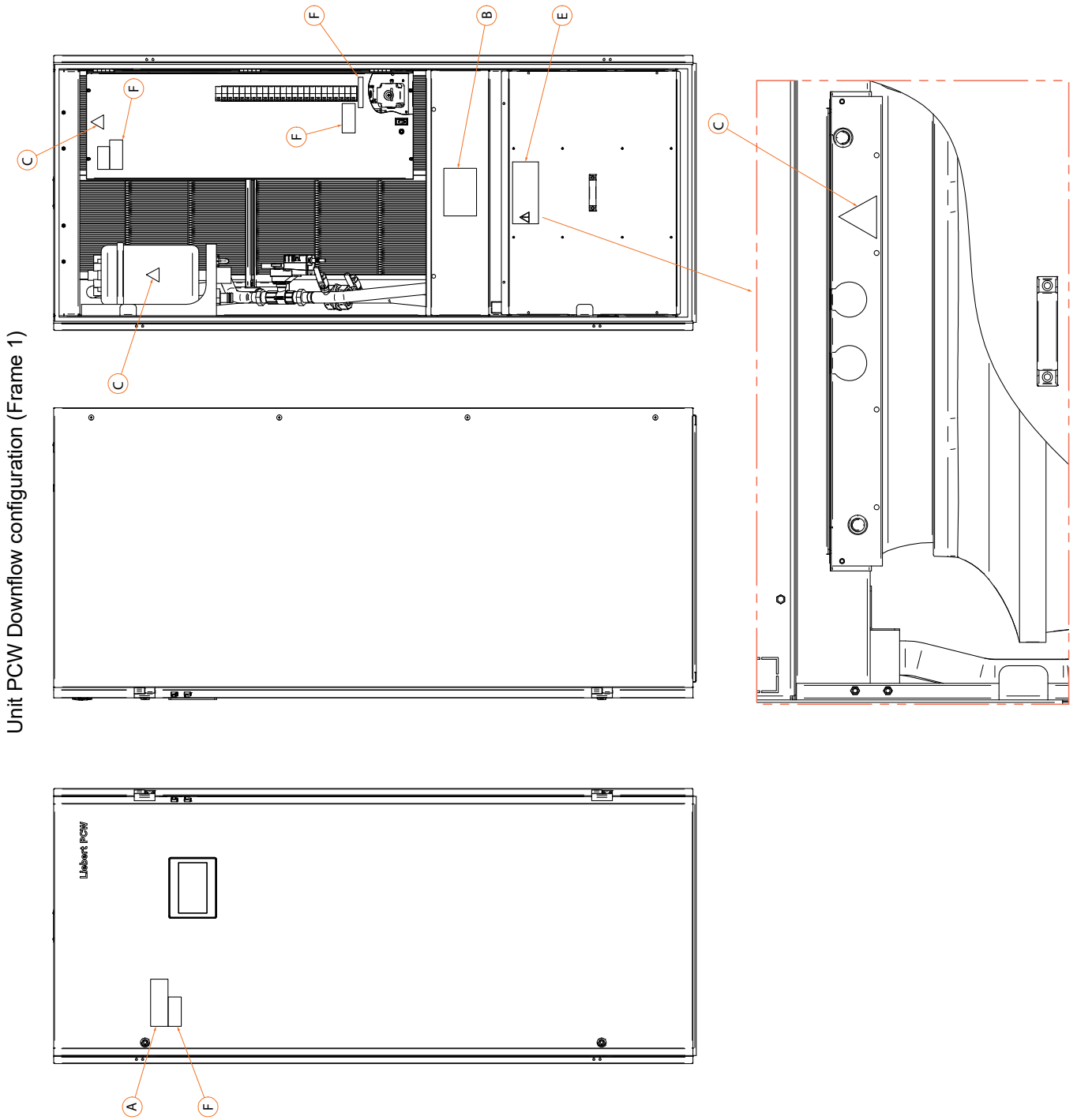

Unit PCW Downflow configurations (Frames 2-3-4-5-6-7)

PCW Frames 3-4-5-6

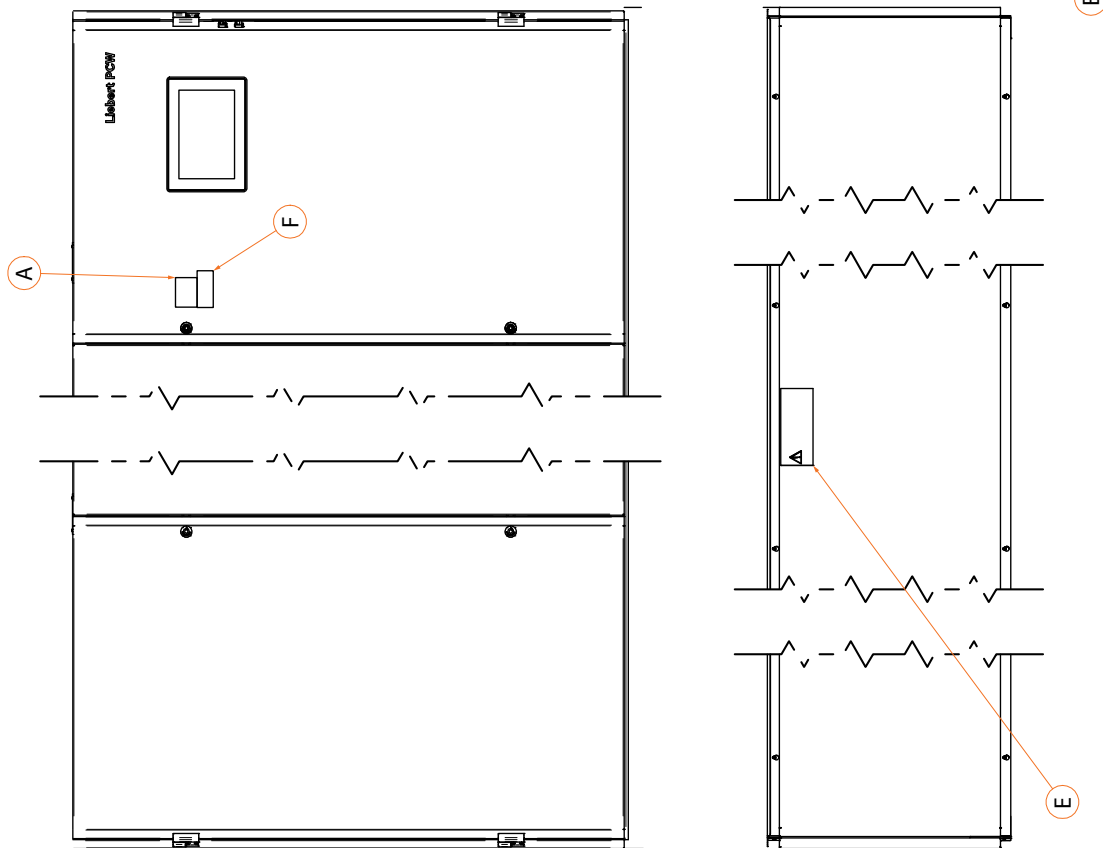

PCW Frame 2

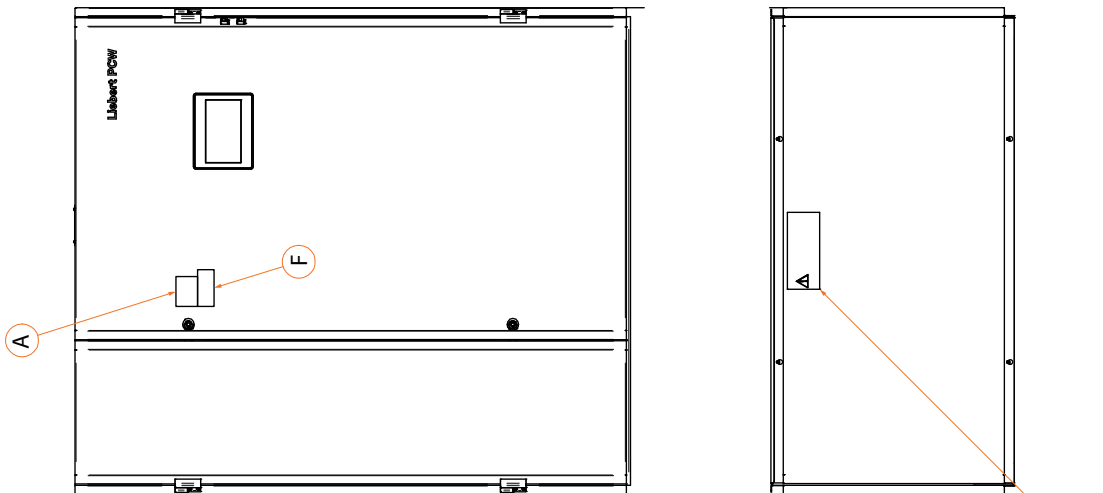

PCW Lateral view

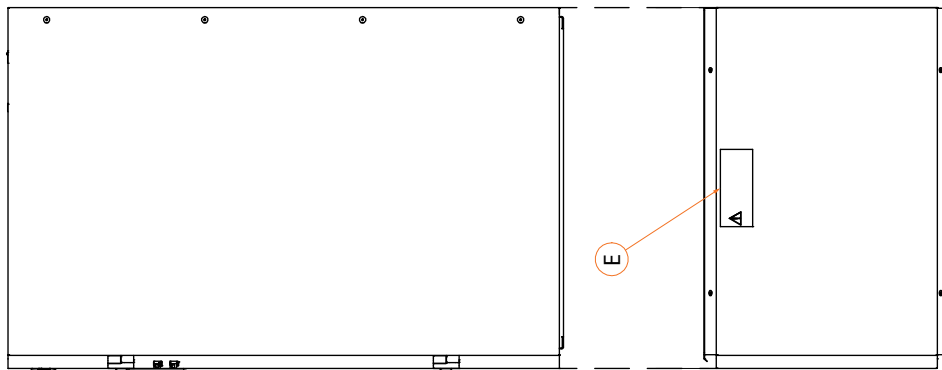

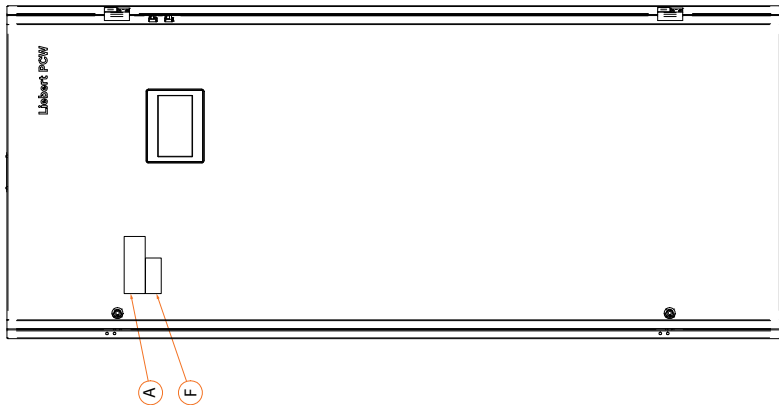
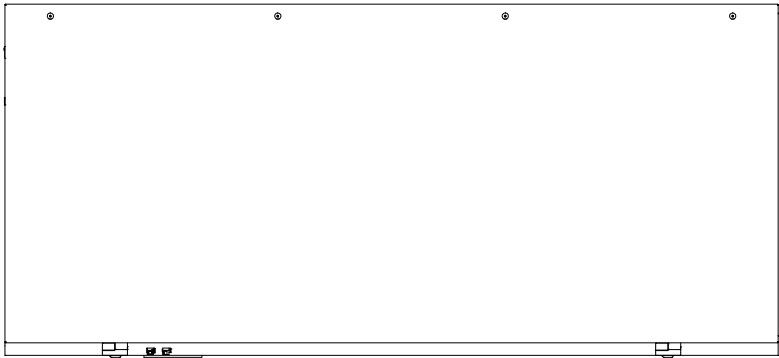
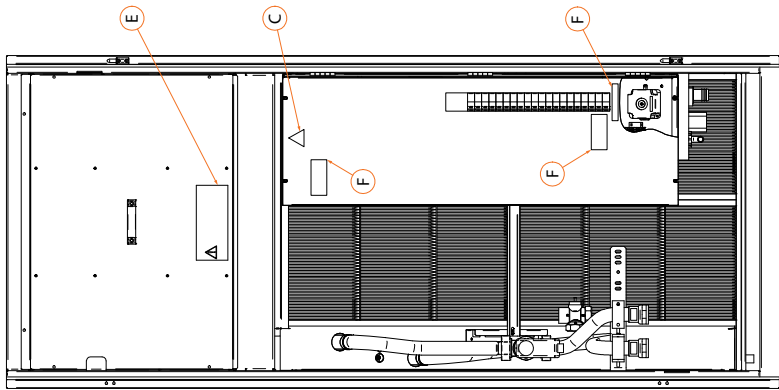
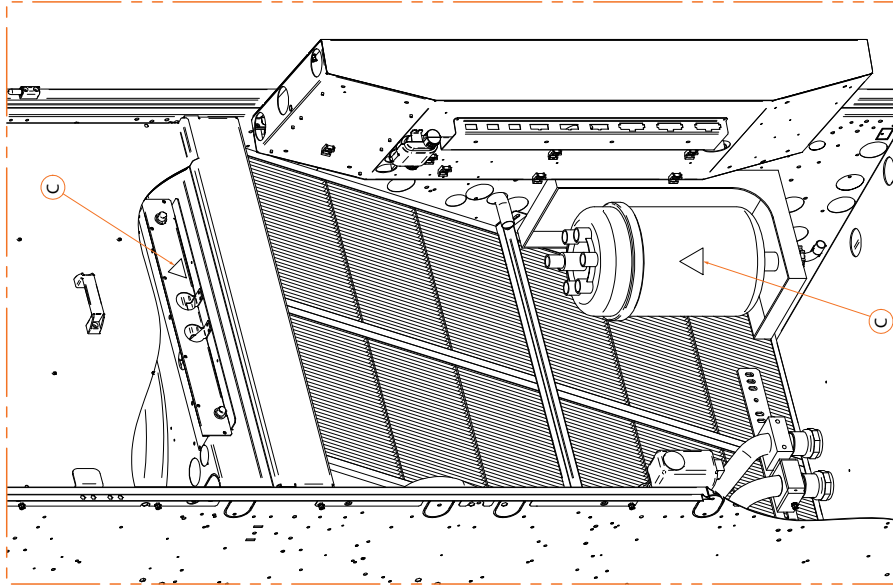

Unit PCW Upflow execution (Size 1)

Unit PCW Upflow execution (Frame 2 - 3 - 4 - 5 - 6 - 7)

PCW Frames 3 - 4 - 5

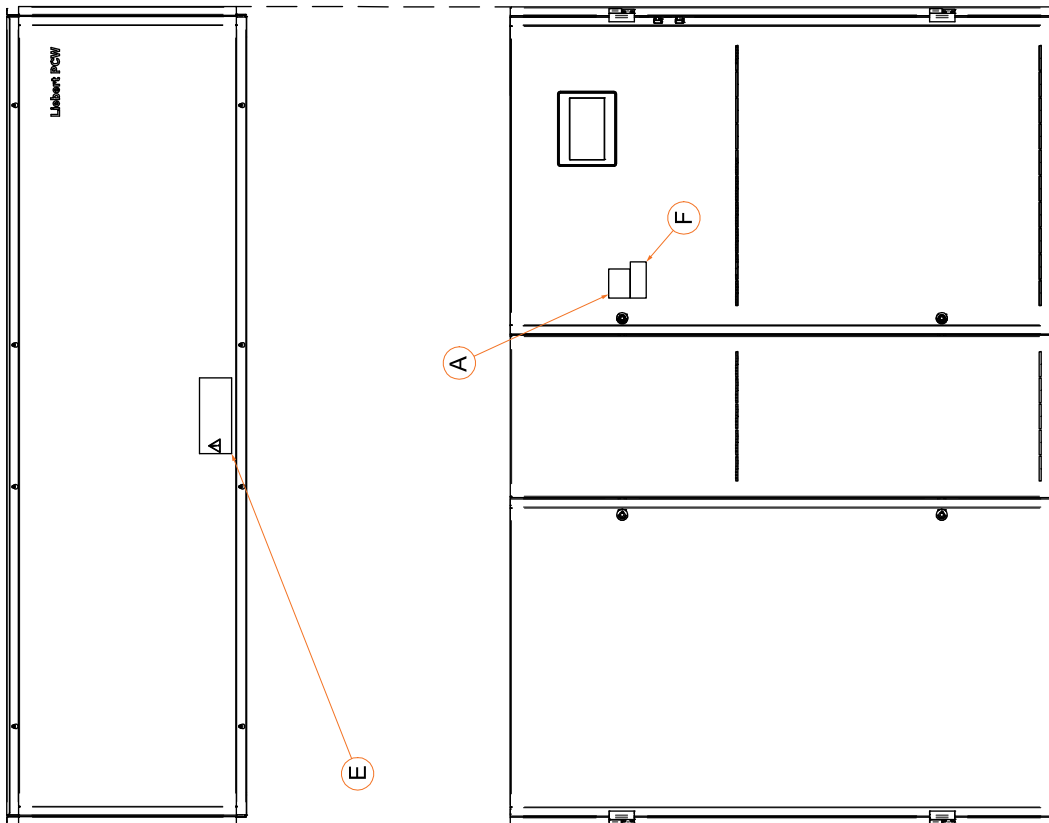

PCW Frame 2

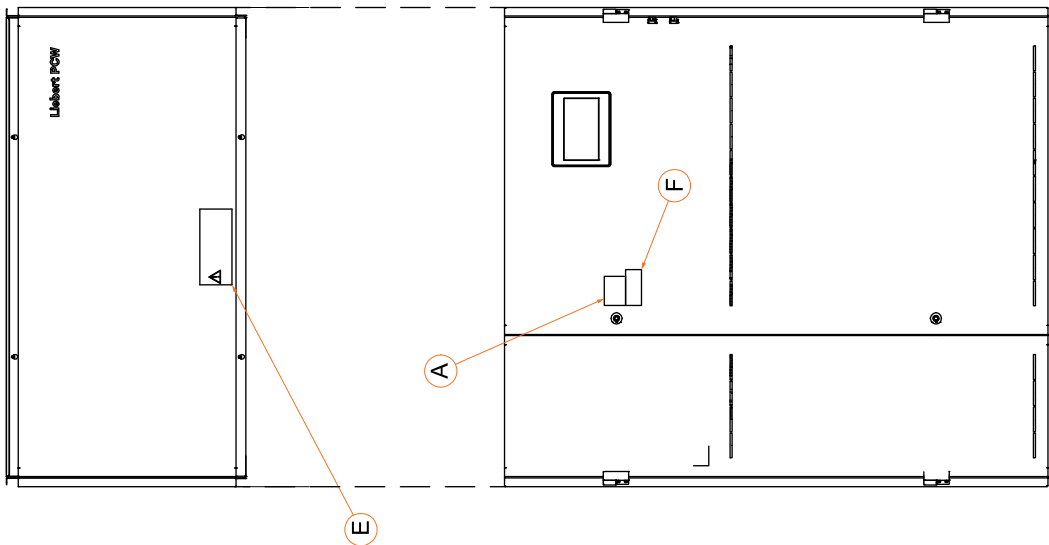

PCW Lateral view

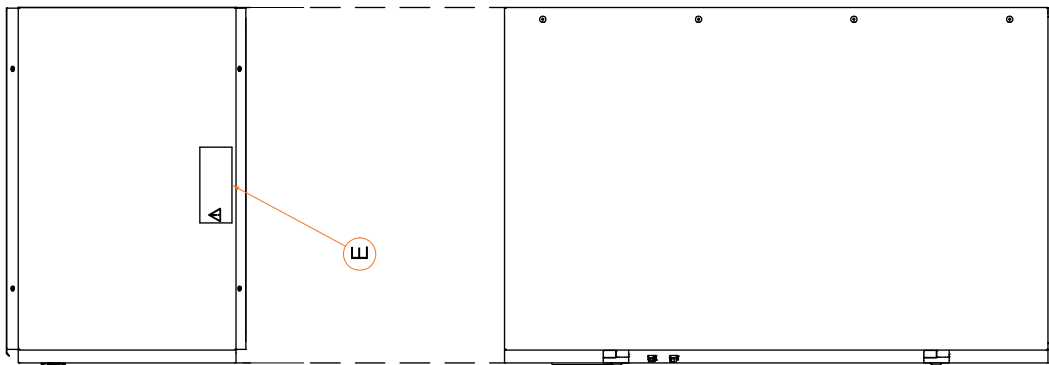

Annex C - Dimensions and Weights

Content

1 - Overview.....	113	7 - Free space from the ceiling.....	116
2 - Overall dimensions.....	114	8 - Hole in the floor for Downflow Up units.....	117
3 - Height from the floor.....	114	9 - Hole in the floor for Downflow Down units.....	118
4 - Height of the accessories at bottom.....	115	10 - Weights.....	119
5 - Height of the accessories on top.....	115	11 - Gravity centers.....	120
6 - Free space from the floor.....	116		

1 - Overview

Identify the model and air distribution of your unit	See 2. <i>Digit Nomenclature</i>
Identify the type of frame of your unit	See 6.1 <i>Structure</i>
Find the overall dimensions for the unit frame, without accessories	See in this annex: 2 - <i>Overall dimensions</i> 3 - <i>Height from the floor</i>
Check which accessories are mounted on the unit	See <i>Annex F - Accessories</i>
Find the dimensions of the accessories Calculate the total height of the unit	See in this annex: 4 - <i>Height of the accessories at bottom</i> 5 - <i>Height of the accessories on top</i>
Check if there is enough free space at top and bottom of the unit	See in this annex: 6 - <i>Free space from the floor</i> 7 - <i>Free space from the ceiling</i>
If you are going to install a Downflow unit: find the dimensions of the hole in the raised floor	See in this annex: 8 - <i>Hole in the floor for Downflow Up units</i> 9 - <i>Hole in the floor for Downflow Down units</i>
Check if there is enough free space for service in front of the unit	See 9.3.2 <i>Space requirements</i>

2 - Overall dimensions

Length by frame type (mm)

Width	Frame type	1	2	3	4	5	6	7
	Number of bays	1	1,5	2	2,5	3	3,5	4

NOTE In the units of frame type 1 the coil section and the fan section are integrated. In the units with frame types 2, 3, 5, 6 and 7 the coil section and the fan section are separate modules that are assembled together.

For all the frames types:

- Depth 890 mm
- Standard height 1970 mm
- Extended height 2570 mm (not available for frame type 1)

3 - Height from the floor

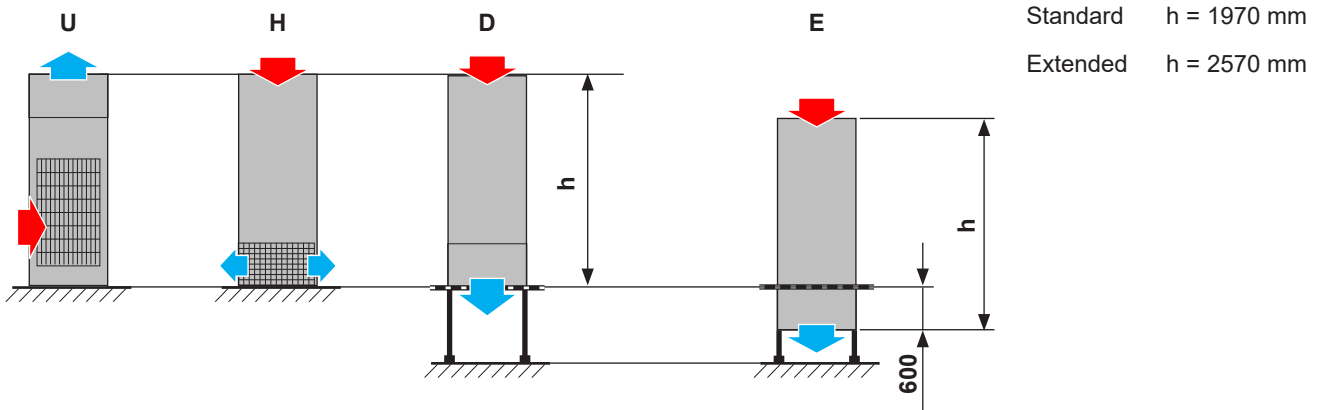

The figure above shows the height from the floor for each air distribution configuration.

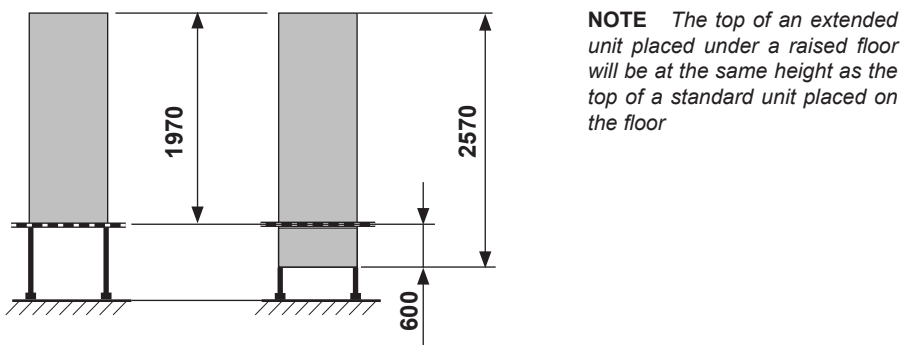

4 - Height of the accessories at bottom

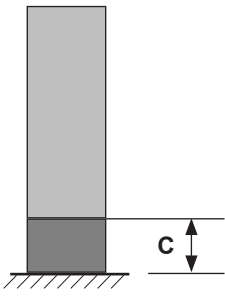

U - Upflow
H - Downflow Frontal

Base module

Height [C]:
- 200 mm

Base module H 600/300 mm
with rear air intake

Height [C]:
- 600 mm for rear/bottom air intake
- 300 mm for bottom air intake

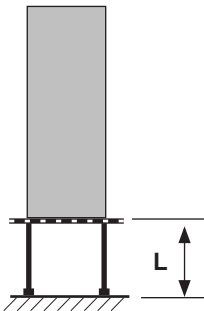

D - Downflow Up
E - Downflow Down

Legs kit

The height [L] is adjustable within the following ranges:
- 30–370 mm
- 370–570 mm
- 570–800 mm

Base frame

The height [L] is adjustable within the following range:
- 120–800 mm

5 - Height of the accessories on top

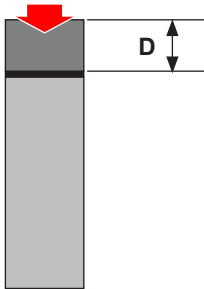

H - Downflow Frontal
D - Downflow Up
E - Downflow Down

Accessory on top of the unit

Height [D]: see the table below.

Accessory	Height D [mm]
Vertical flow extension hood	500 - 600 - 700 - 800 - 900
Hood with high efficiency air filter	600 - 900
Plenum with silencing cartridges	600 - 900
Horizontal hood with grid	600
Air economizer	850

6 - Free space from the floor

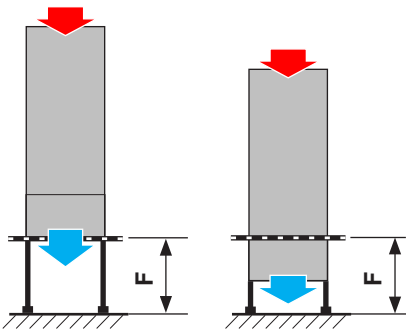

D - Downflow Up
E - Downflow Down

Free space [F] between the bottom of the unit and the floor

- Maximum: 800 mm, which is the maximum available height for the base frame or legs kit (see above).
- Minimum to obtain the declared performances: 600 mm
- Minimum allowable to obtain the minimum working conditions: 300 mm

7 - Free space from the ceiling

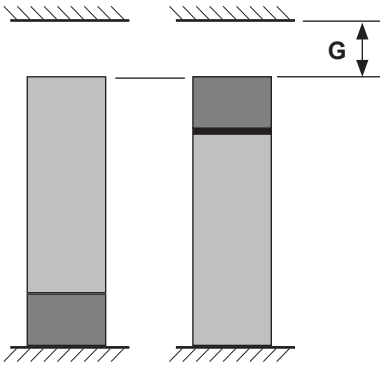

H - Downflow Frontal
D - Downflow Up
E - Downflow Down

Free space [G] between the ceiling and the unit top, including any accessory mounted on top or bottom

- Minimum to obtain the declared performances: 600 mm
- Minimum allowable to obtain the minimum working conditions: 300 mm

8 - Hole in the floor for Downflow Up units

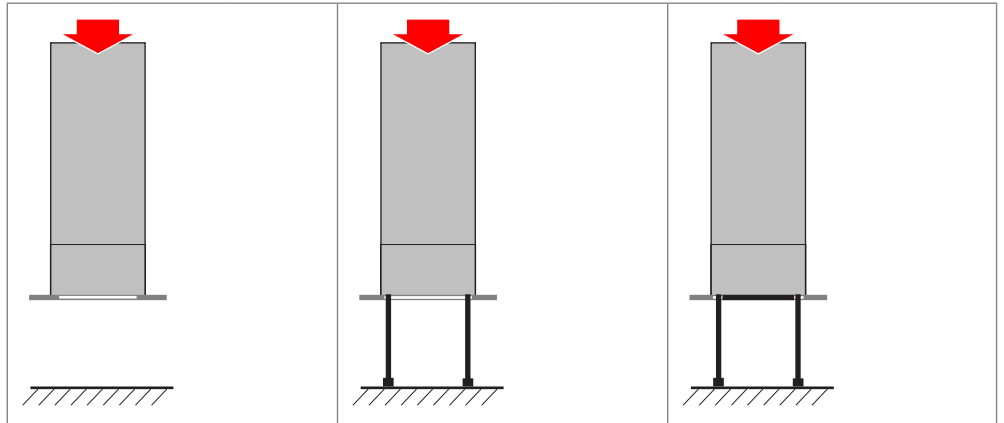
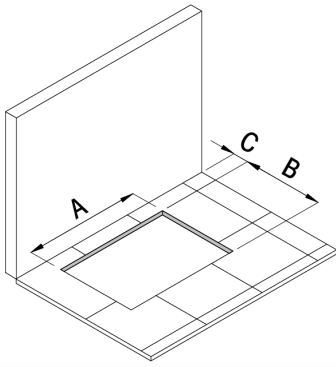

Frame type	No accessories for support			With legs kit			With base frame		
	A [mm]	B [mm]	C [mm]	A [mm]	B [mm]	C [mm]	A [mm]	B [mm]	C [mm]
1 840 890	740	760	70	Not available			804	830	30
2 1200 890	1 100	760	70	1 156	820	30	1 176	840	30
3 1750 890	1 650	760	70	1 706	820	30	1 726	840	30
4 2050 890	1 950	760	70	2 006	820	30	2 026	840	30
5 2550 890	2 450	760	70	2 506	820	30	2 526	840	30
6 2950 890	2 850	760	70	2 906	820	30	2 926	840	30
7 3350 890	3 250	760	70	3 306	820	30	3 326	840	30

NOTE [C] is the minimum free space between the unit at its final position and any back wall or obstacle. You might need more space for assembly or installation operations. In that case, do the assembly or installation operation nearby and then place the unit at the final position.

9 - Hole in the floor for Downflow Down units

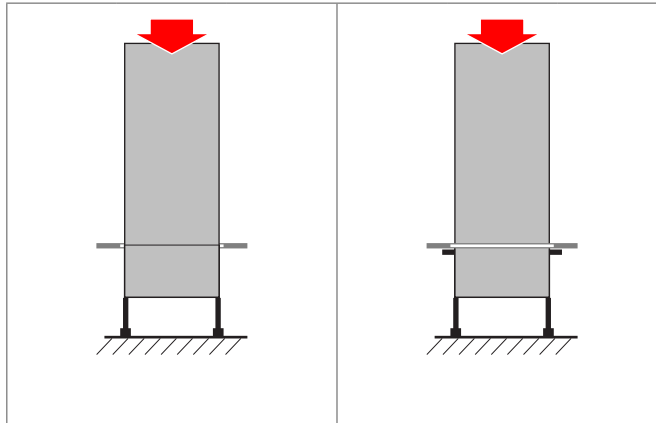
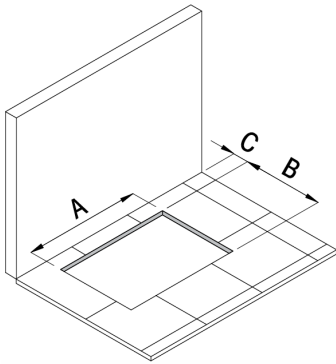

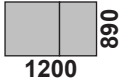
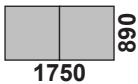
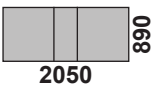
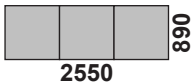
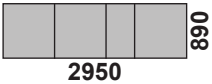
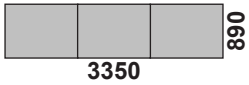
Frame type	No accessories for support			With floor tiles support kit		
	A [mm]	B [mm]	C [mm]	A [mm]	B [mm]	C [mm]
1 	Not available			Not available		
2 	1 182	846	20	1 220	885	50
3 	1 732	846	20	1 770	885	50
4 	2 032	846	20	2 070	885	50
5 	2 532	846	20	2 570	885	50
6 	2 932	846	20	2 970	885	50
7 	3 332	846	20	3 370	885	50

NOTE [C] is the minimum free space between the unit at its final position and any back wall or obstacle. You might need more space for assembly or installation operations. In that case, do the assembly or installation operation nearby and then place the unit at the final position.

10 - Weights

Table 27 - Unit weight

MODEL	Single circuit unit [kg]	Double circuit unit [kg]	"Packaging" [kg]
Standard Height unit			
PW025	329	-	19
PW030	339	-	19
PW035	379	-	23
PW040	396	419	23
PW045	509	-	28
PW060	539	552	28
PW070	613	-	31
PW080	629	649	31
PW095	752	-	42
PW110	782	795	42
PW145	866	879	47
PW170	1005	1080	58
Extended Height unit [Coil Module] ⁽¹⁾			
PW046	299	326	23
PW066	439	483	28
PW091	502	531	31
PW136	617	640	42
PW161	707	720	47
PW201	720	733	58
Extended Height unit [Fan Base Frame] ⁽¹⁾			
BFW12	91		26
BFW17	150		35
BFW20	170		41
BFW25	218		54
BFW29	245		61
BFW33	305		78
Extended Height unit [Fan Base Module/Fan Top Plenum] ⁽¹⁾			
BMW/TPW 12	91		26
BMW/TPW 17	150		35
BMW/TPW 20	170		41
BMW/TPW 25	218		54
BMW 29	245		61
BMW 33	305		78

(1) For Extended Height version, the total unit weight must be calculated by adding the Coil Module weight and Fan Section weight

NOTE: The listed Coil Module weight and Fan Section weight is the maximum weight including all additional options.

11 - Gravity centers

Gravity center - Frame type 1 (1 bay) - Standard - Downflow

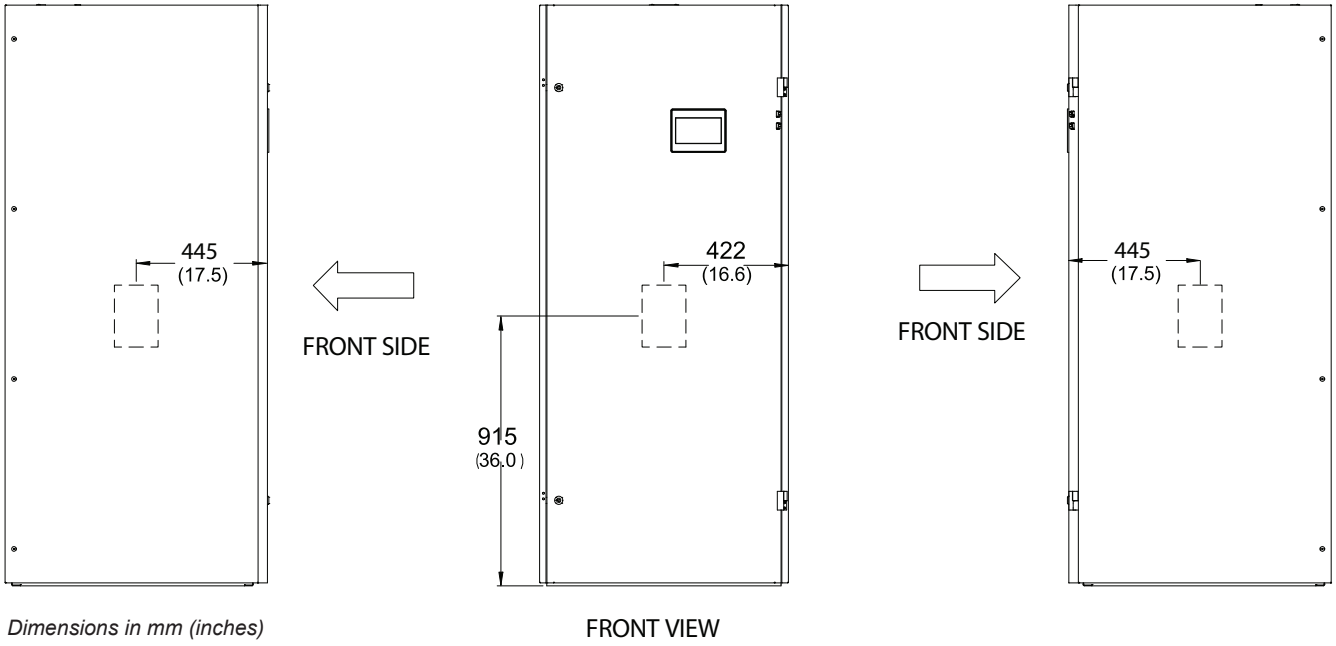

Gravity center - Frame type 1 (1 bay) - Standard - Upflow

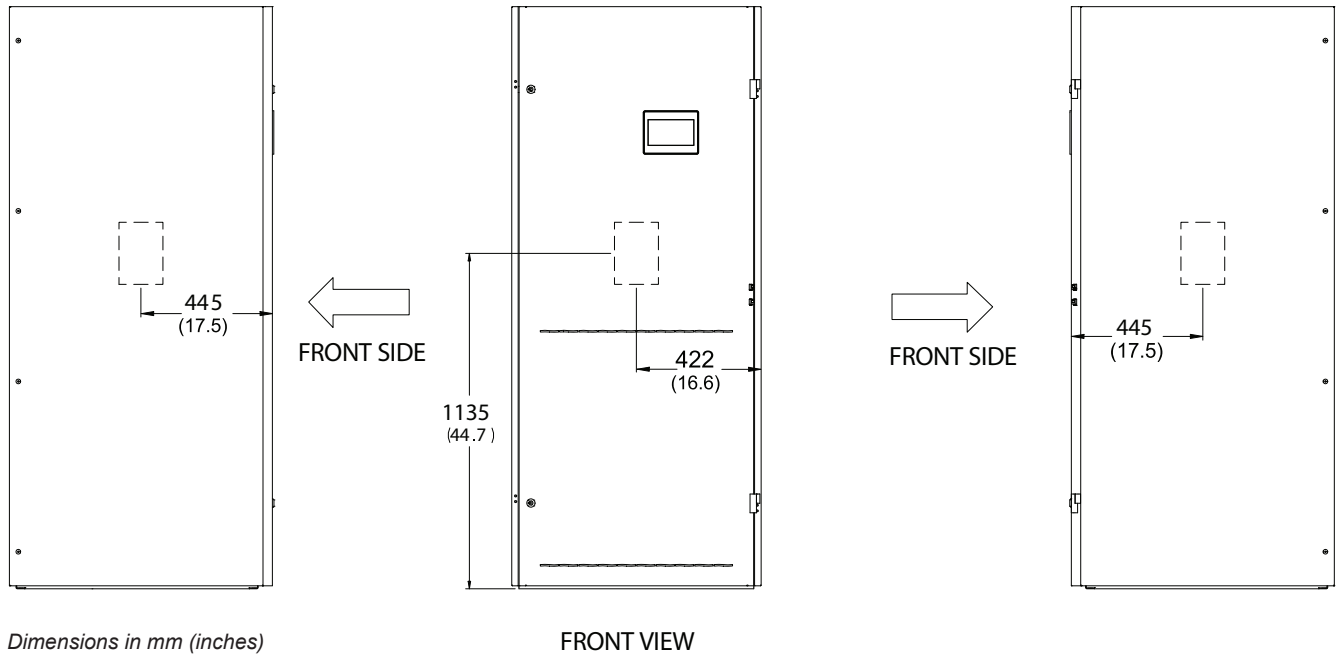

Gravity center - Frame type 2 (1,5 bays) - Standard - Downflow

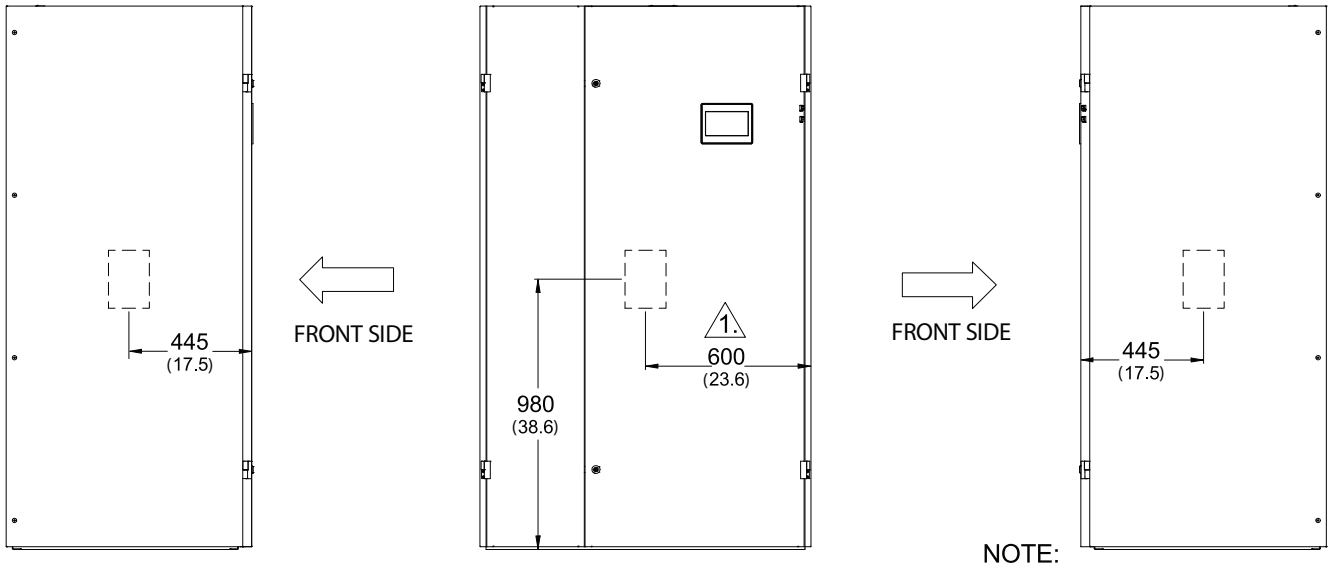

Dimensions in mm (inches)

FRONT VIEW

NOTE: FOR DUAL CIRCUIT "W" MOVE BY 30 MM (1.2 IN) TO THE RIGHT SIDE

Gravity center - Frame type 2 (1,5 bays) - Standard - Upflow

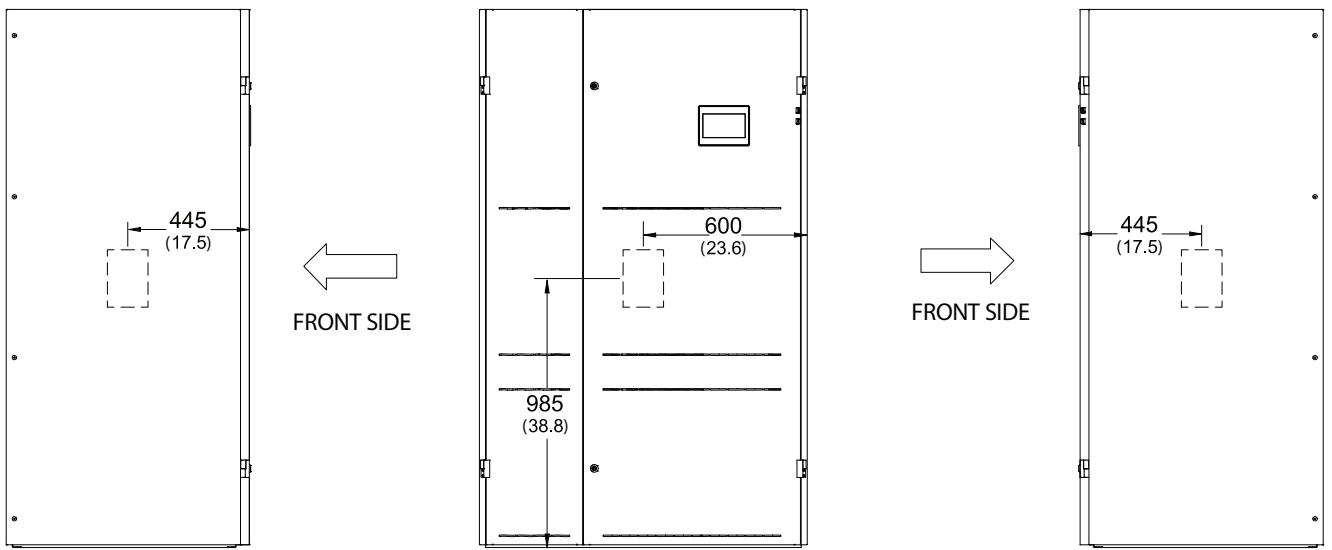

Dimensions in mm (inches)

FRONT VIEW

Gravity center - Frame type 3 (2 bays) - Standard - Downflow

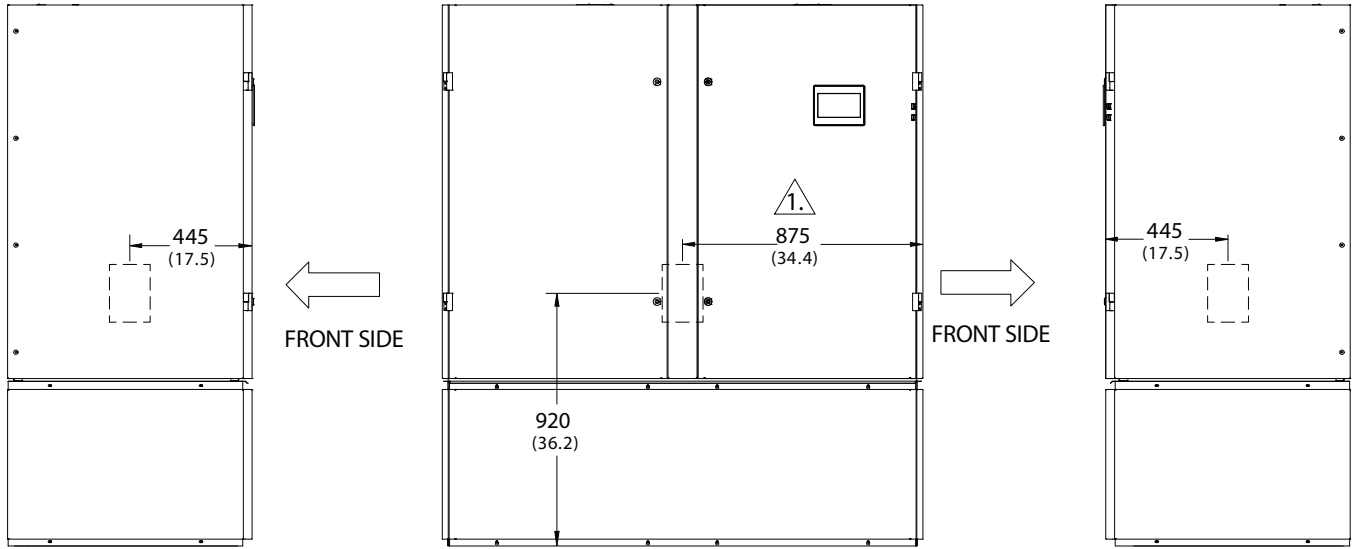

Dimensions in mm (inches)

FRONT VIEW

△ 1. FOR DUAL CIRCUIT "W" MOVE BY 30 MM (1.2 IN) TO THE RIGHT SIDE

Gravity center - Frame type 3 (2 bays) - Standard - Upflow

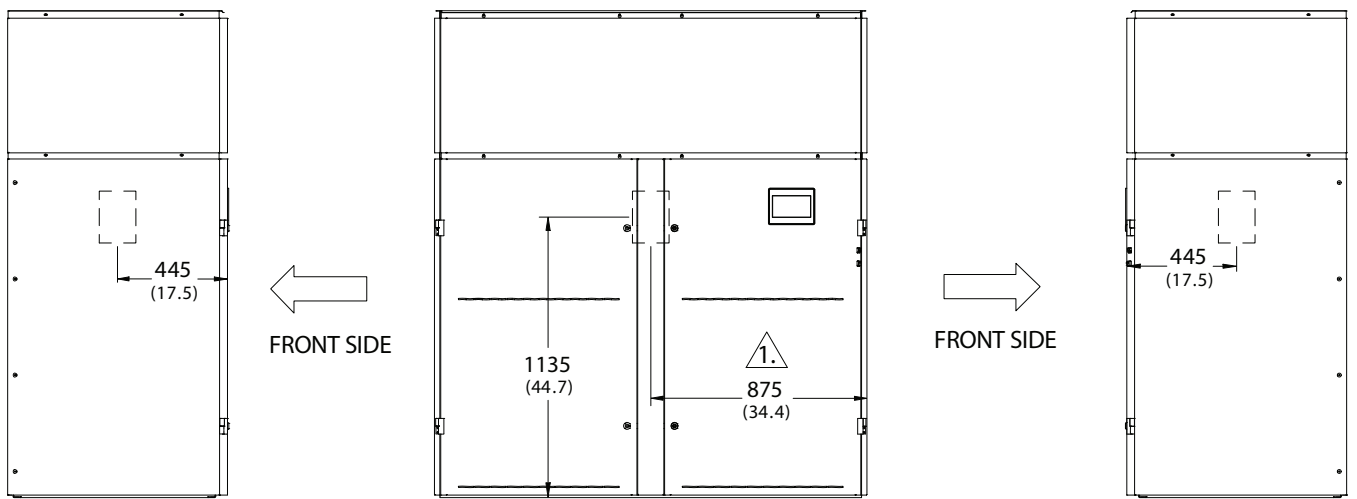

Dimensions in mm (inches)

FRONT VIEW

△ 1. FOR DUAL CIRCUIT "W" MOVE BY 30 MM (1.2 IN) TO THE RIGHT SIDE

Gravity center - Frame type 3 (2 bays) - Extended - Downflow

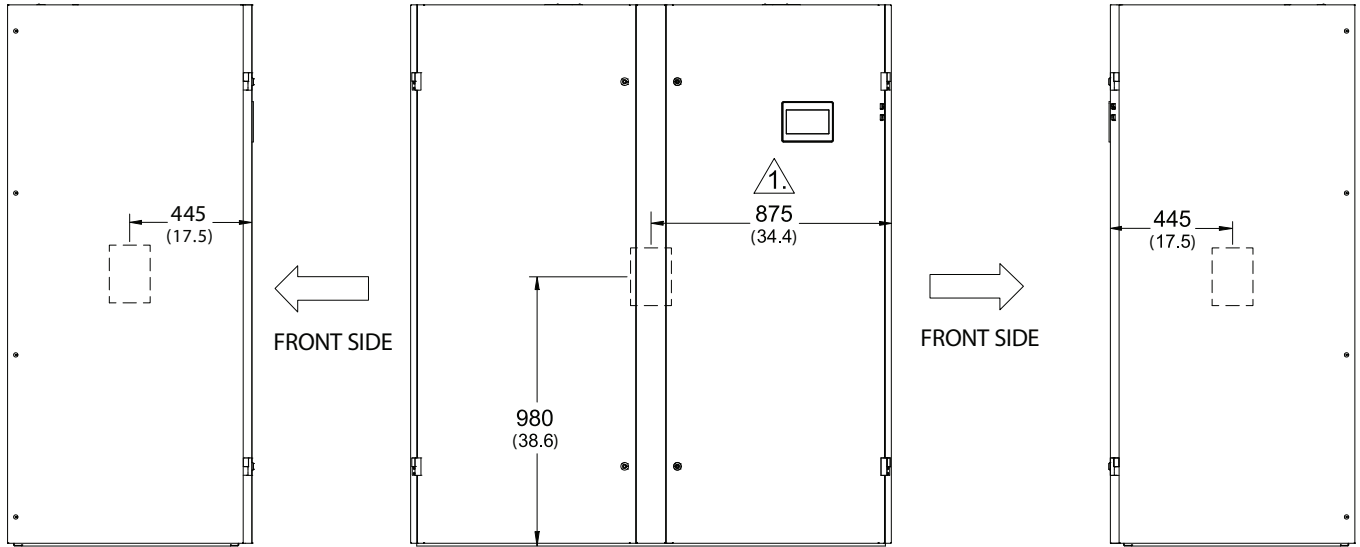

Dimensions in mm (inches)

FRONT VIEW

FOR DUAL CIRCUIT "W" MOVE BY 30 MM (1.2 IN) TO THE RIGHT SIDE

Gravity center - Frame type 3 (2 bays) - Extended - Upflow

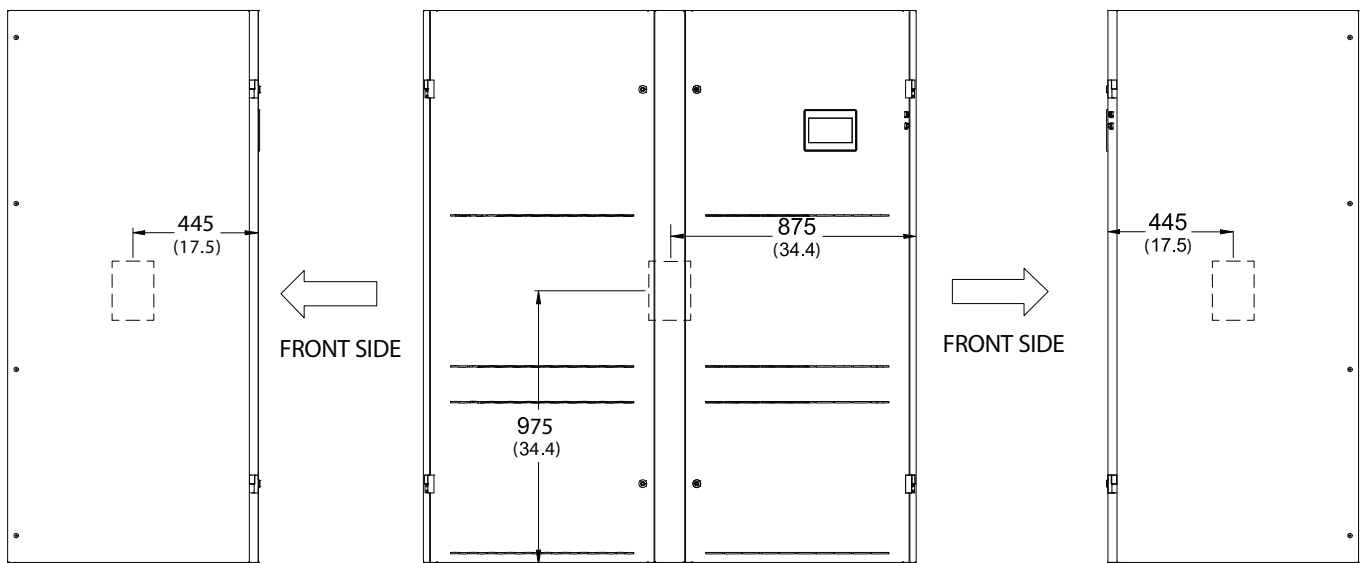

Dimensions in mm (inches)

FRONT VIEW

Gravity center - Frame type 4 (2,5 bays) - Standard - Downflow

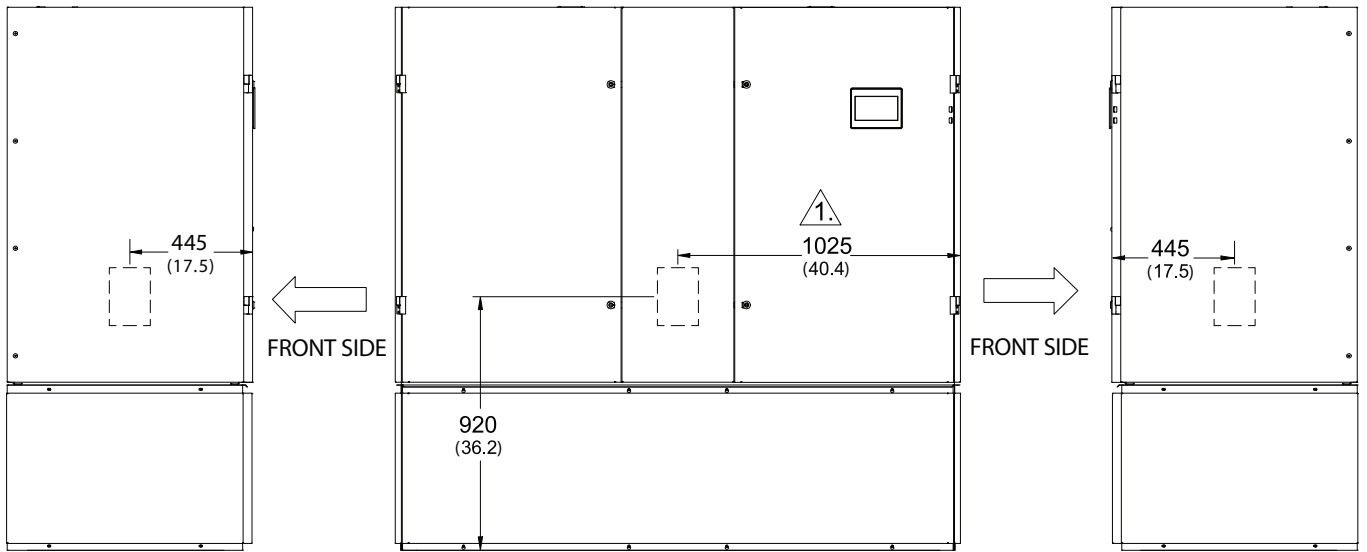

Dimensions in mm (inches)

FRONT VIEW

1. FOR DUAL CIRCUIT "W" MOVE BY 30 MM (1.2 IN) TO THE RIGHT SIDE

Gravity center - Frame type 4 (2,5 bays) - Standard - Upflow

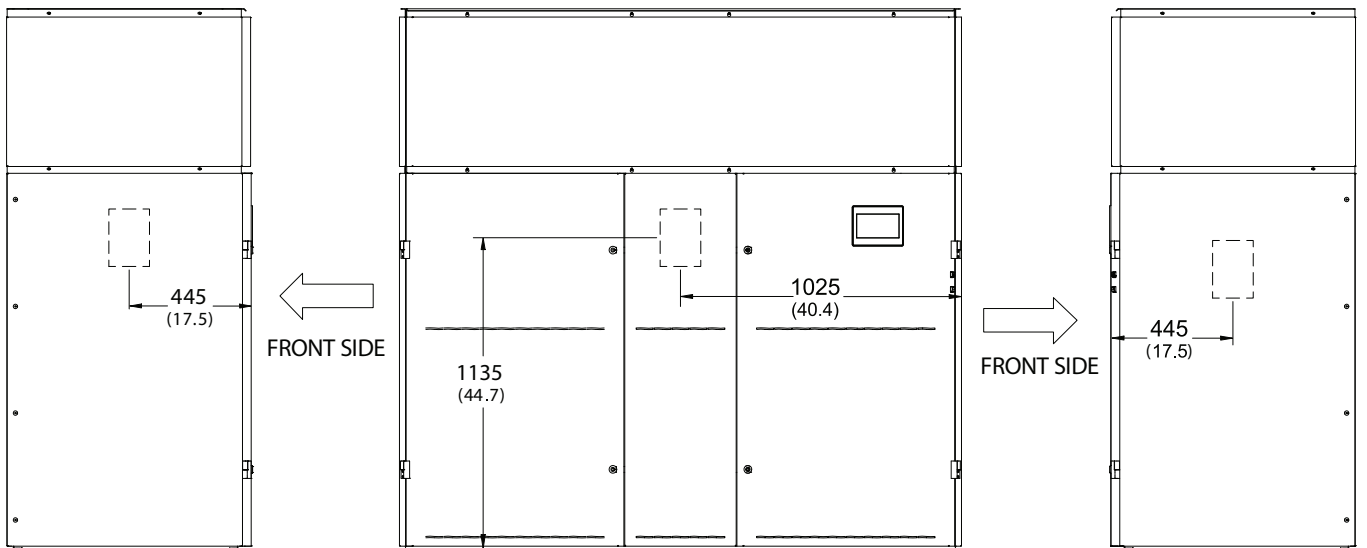

Dimensions in mm (inches)

FRONT VIEW

THE STICKER MUST BE PLACED ALSO ON BACK SIDE!!!

Gravity center - Frame type 4 (2,5 bays) - Extended - Downflow

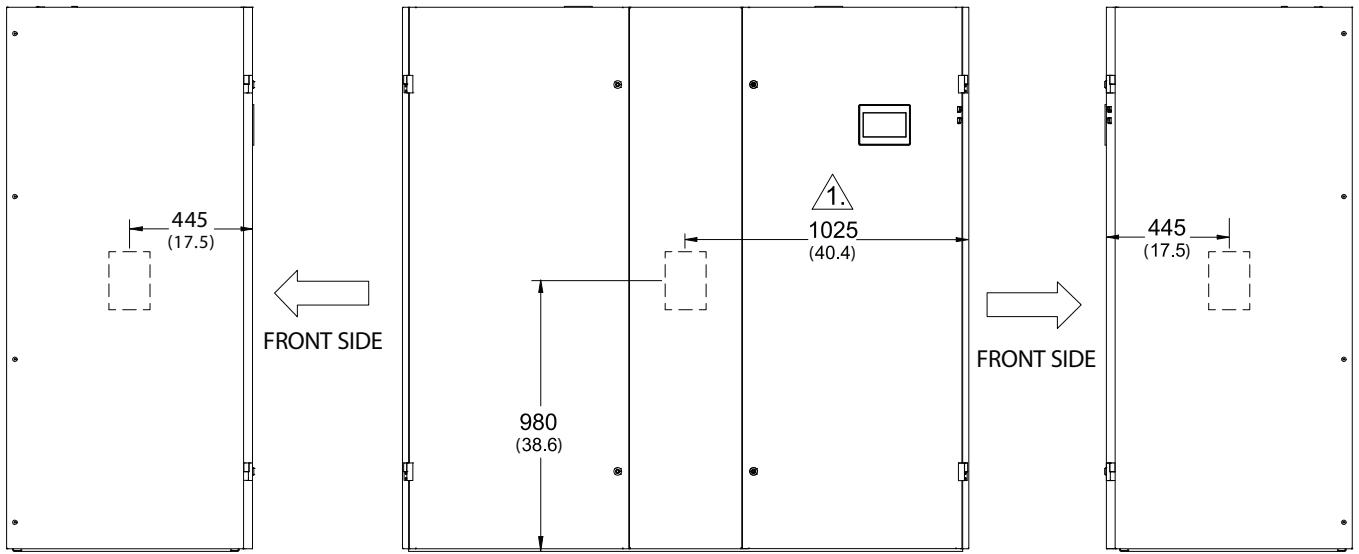

Dimensions in mm (inches)

FRONT VIEW

FOR DUAL CIRCUIT "W" MOVE BY 30 MM (1.2 IN) TO THE RIGHT SIDE

Gravity center - Frame type 4 (2,5 bays) - Extended - Upflow

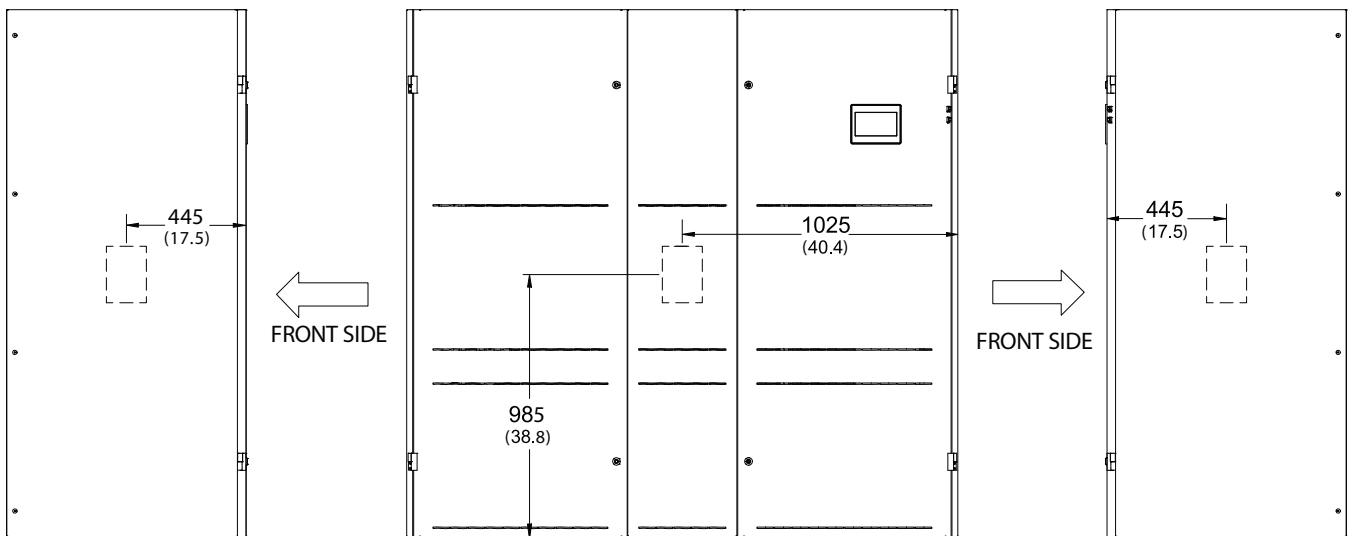

Dimensions in mm (inches)

FRONT VIEW

Gravity center - Frame type 5 (3 bays) - Standard - Downflow

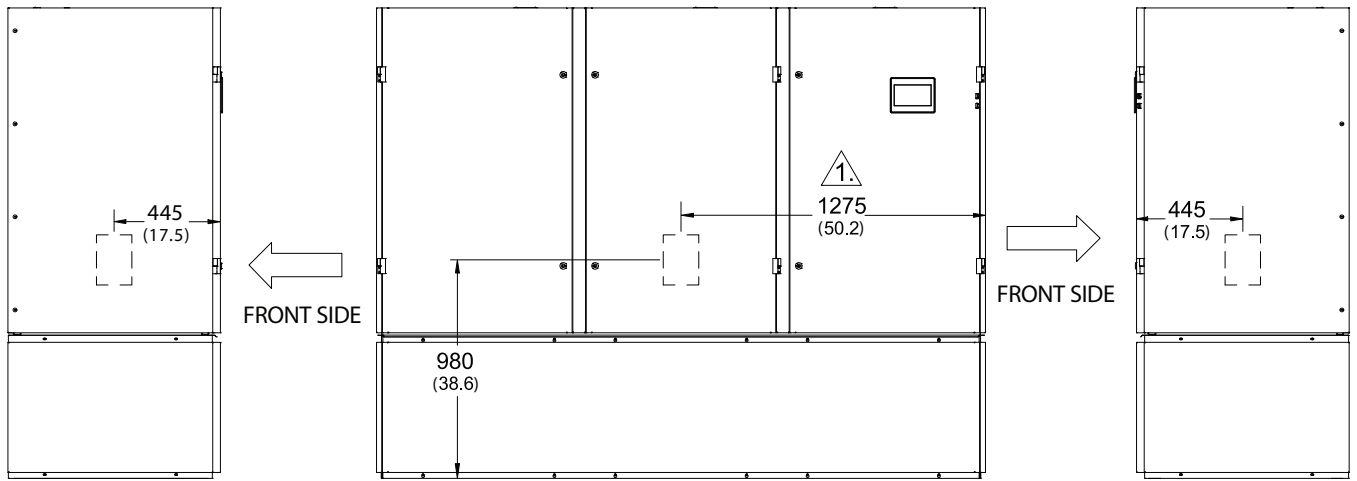

Dimensions in mm (inches)

FRONT VIEW

1. FOR DUAL CIRCUIT "W" MOVE BY 30 MM (1.2 IN) TO THE RIGHT SIDE

Gravity center - Frame type 5 (3 bays) - Standard - Upflow

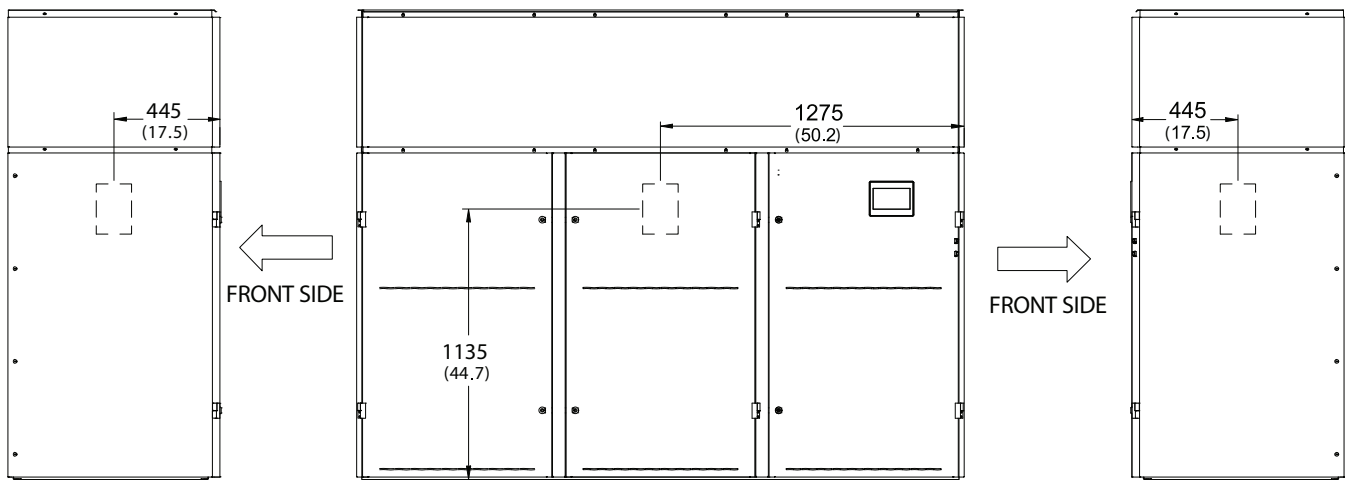

Dimensions in mm (inches)

FRONT VIEW

Gravity center - Frame type 5 (3 bays) - Extended - Downflow

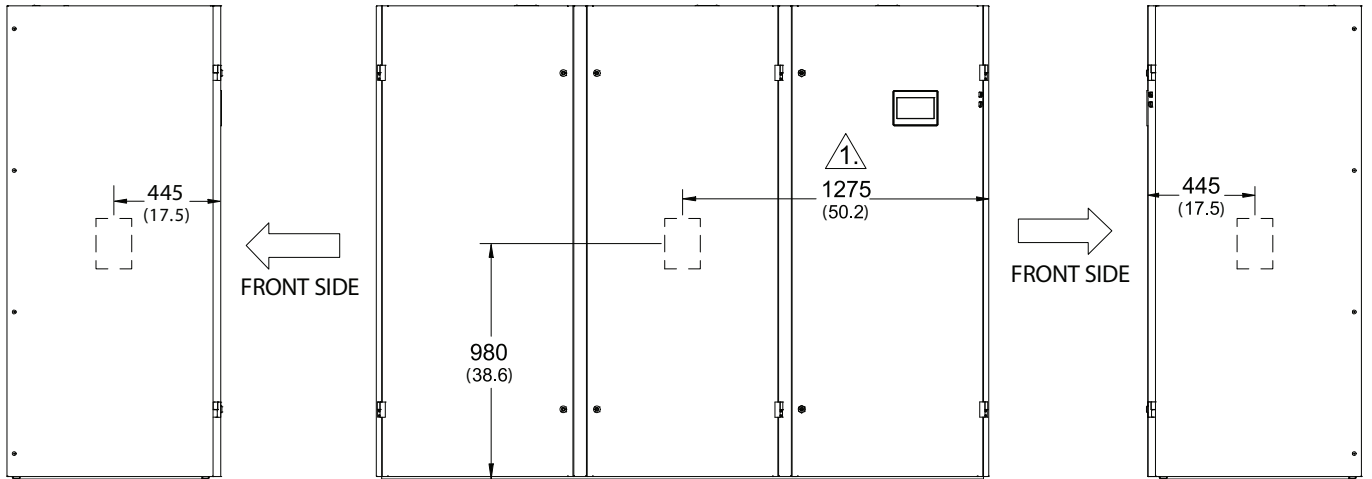

Dimensions in mm (inches)

FRONT VIEW

Gravity center - Frame type 6 (3,5 bays) - Standard - Downflow

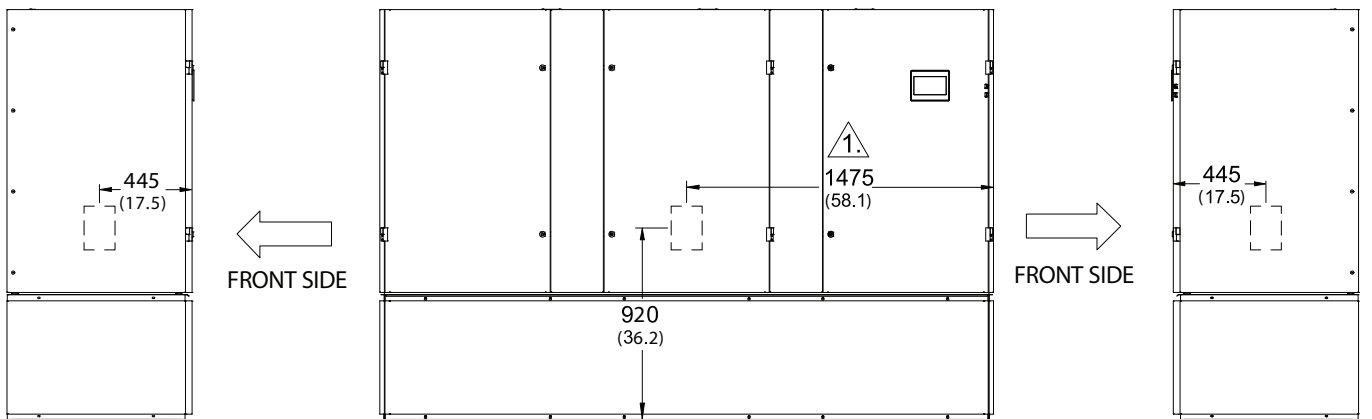

Dimensions in mm (inches)

FRONT VIEW

 FOR DUAL CIRCUIT "W" MOVE BY 30 MM (1.2 IN) TO THE RIGHT SIDE

Gravity center - Frame type 6 (3,5 bays) - Extended - Downflow

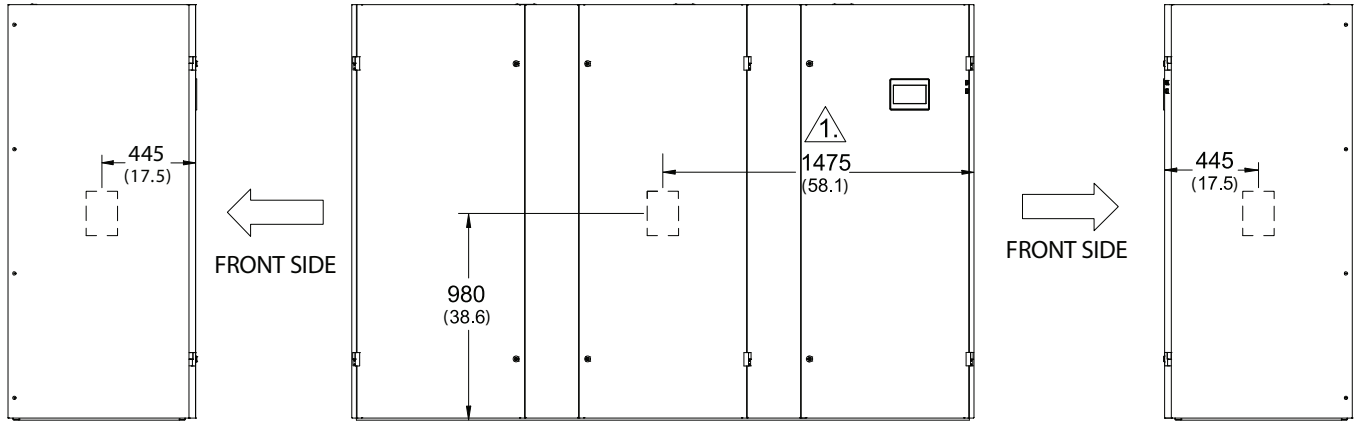

Dimensions in mm (inches)

FRONT VIEW

 FOR DUAL CIRCUIT "W" MOVE BY 30 MM (1.2 IN) TO THE RIGHT SIDE

Gravity center - Frame type 7 (4 bays) - Standard - Downflow

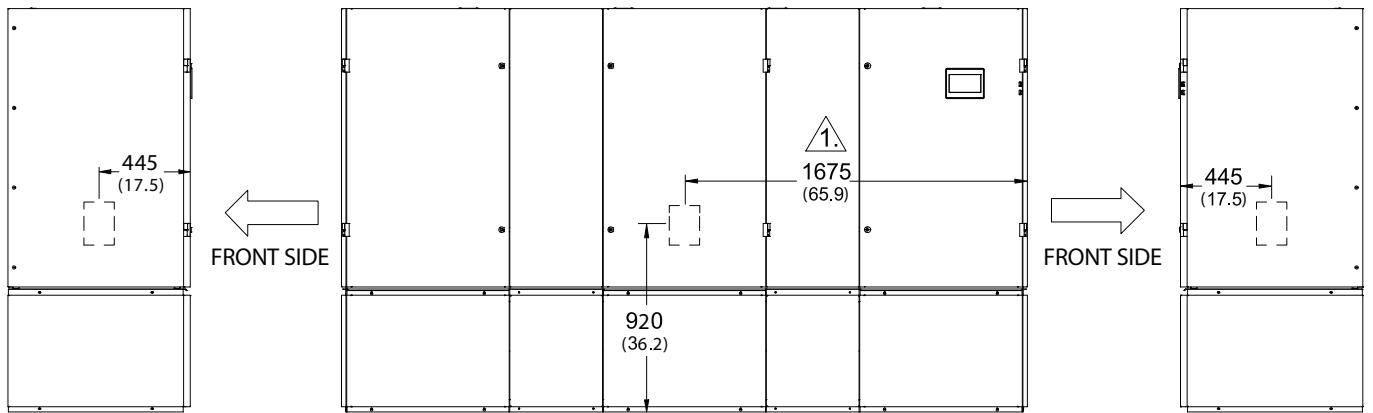

Dimensions in mm (inches)

FRONT VIEW

 FOR DUAL CIRCUIT "W" MOVE BY 30 MM (1.2 IN) TO THE RIGHT SIDE

Gravity center - Frame type 7 (4 bays) - Extended - Downflow

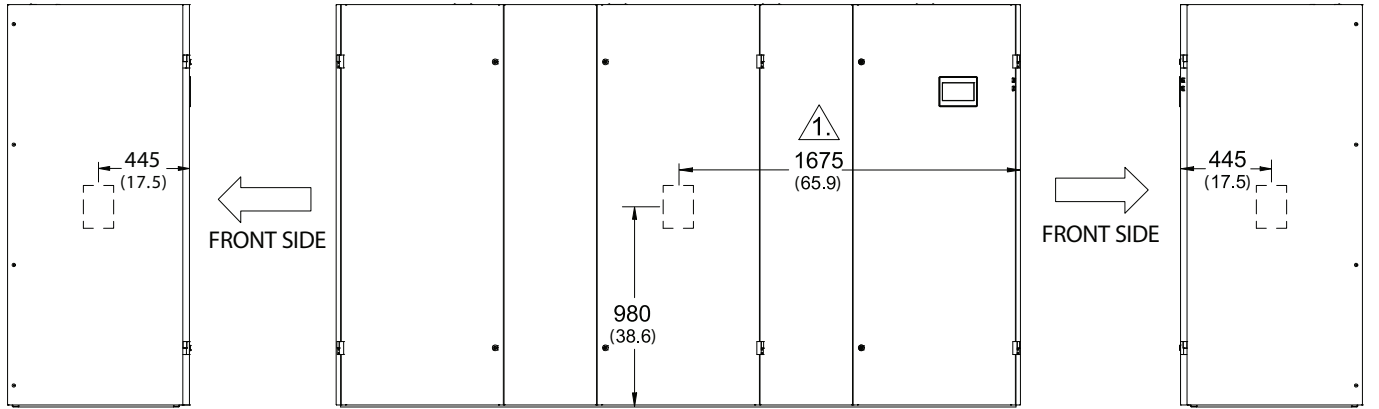

Dimensions in mm (inches)

FRONT VIEW

FOR DUAL CIRCUIT "W" MOVE BY 30 MM (1.2 IN) TO THE RIGHT SIDE

Annex D - Connections

Content

- 1 - Hydraulic and electrical connections - Downflow versions...132
- 2 - Hydraulic and electrical connections - Upflow versions...133

Key to symbols

Symbol	Description	See ...
ICW	Chilled water inlet (single circuit)	Chapter 5.3 <i>Cooling System</i>
OCW	Chilled water outlet (single circuit)	
ICW1	Chilled water inlet circuit 1 (double circuit)	
OCW1	Chilled water outlet circuit 1 (double circuit)	
ICW2	Chilled water inlet circuit 2 (double circuit)	
OCW2	Chilled water outlet circuit 2 (double circuit)	
HF	Humidifier feed	<i>Annex F - Electrode Humidifier</i>
HD	Humidifier drain	<i>Annex G - Infrared Humidifier</i>
EC	Electrical power supply	Chapter 6.4.1 <i>Unit electrical data</i>
EC aux	Low voltage cables	
CD	Condensate Drain	Chapter 6.4.6 <i>Condensate pump</i>

NOTE All the dimensions are in millimeters

Tab. 1 - Hydraulic and electrical connections – Downflow versions

Unit Connection		PW025 PW030	PW035 PW040 PW046	PW045 PW060 PW066	PW070 PW080 PW091	PW095 PW110 PW136	PW145 PW161	PW170 PW201	Height from unit bottom
ICW	Chilled water inlet (single chilled water circuit)	Rp 1 ¼ ISO 7/1	Rp 1 ¼ ISO 7/1	Rp 1 ½ ISO 7/1	O.D. Ø54 mm** R 2 - ISO7/1***	O.D. Ø64 mm** R 2½ ISO7/1***	O.D. Ø64 mm** R 2½ ISO7/1***	O.D. Ø64 mm** R 2½ ISO7/1***	394
OCW	Chilled water ou- tlet (single chilled water circuit)	Rp 1 ¼ ISO 7/1	Rp 1 ¼ ISO 7/1	Rp 1 ½ ISO 7/1	O.D. Ø54 mm** R 2 - ISO7/1***	O.D. Ø64 mm** R 2½ ISO7/1***	O.D. Ø64 mm** R 2½ ISO7/1***	O.D. Ø64 mm** R 2½ ISO7/1***	344
ICW1	Chilled water inlet 1 (double chilled water circuit)	NA	Rp 1 ¼ ISO 7/1	Rp 1 ½ ISO 7/1	Rp 1 ½ ISO 7/1	O.D. Ø54 mm** R 2 - ISO7/1***	O.D. Ø54 mm** R 2 - ISO7/1***	O.D. Ø54 mm** R 2 - ISO7/1***	394
OCW 1	Chilled water ou- tlet 1 (double chilled water circuit)	NA	Rp 1 ¼ ISO 7/1	Rp 1 ½ ISO 7/1	Rp 1 ½ ISO 7/1	O.D. Ø54 mm** R 2 - ISO7/1***	O.D. Ø54 mm** R 2 - ISO7/1***	O.D. Ø54 mm** R 2 - ISO7/1***	344
ICW2	Chilled water inlet 2 (double chilled water circuit)	NA	Rp 1 ¼ ISO 7/1	Rp 1 ½ ISO 7/1	Rp 1 ½ ISO 7/1	O.D. Ø54 mm** R 2 - ISO7/1***	O.D. Ø54 mm** R 2 ISO7/1***	O.D. Ø54 mm** R 2 - ISO7/1***	394
OCW 2	Chilled water ou- tlet 2 (double chilled water circuit)	NA	Rp 1 ¼ ISO 7/1	Rp 1 ½ ISO 7/1	Rp 1 ½ ISO 7/1	O.D. Ø54 mm** R 2 - ISO7/1***	O.D. Ø54 mm** R 2 - ISO7/1***	O.D. Ø54 mm** R 2 - ISO7/1***	344
CD	Condensate drain	I.D. Ø20 [mm]							-
CD*	Condensate drain	I.D. Ø20 [mm]							-
HF	Humidifier feed	R ½ - ISO 7/1 (Electrode Humidifier), O.D. 6 [mm] (Infrared Humidifier)							-
HD	Humidifier drain	I.D. Ø32 [mm] (Electrode Humidifier), I.D. Ø22 [mm] (Infrared Humidifier)							-
EC	Electrical power supply	Ø 48 [mm]							-
EC aux	Low voltage cables	Ø 40 - Ø 36 [mm]							-

CD* only for unit from PH095 toPH201

** Grooved connection

*** Optional. Threaded union on request

NA = Not Available

Fig. 1. Downflow units, dimensions for Piping Bottom Option (Top view)

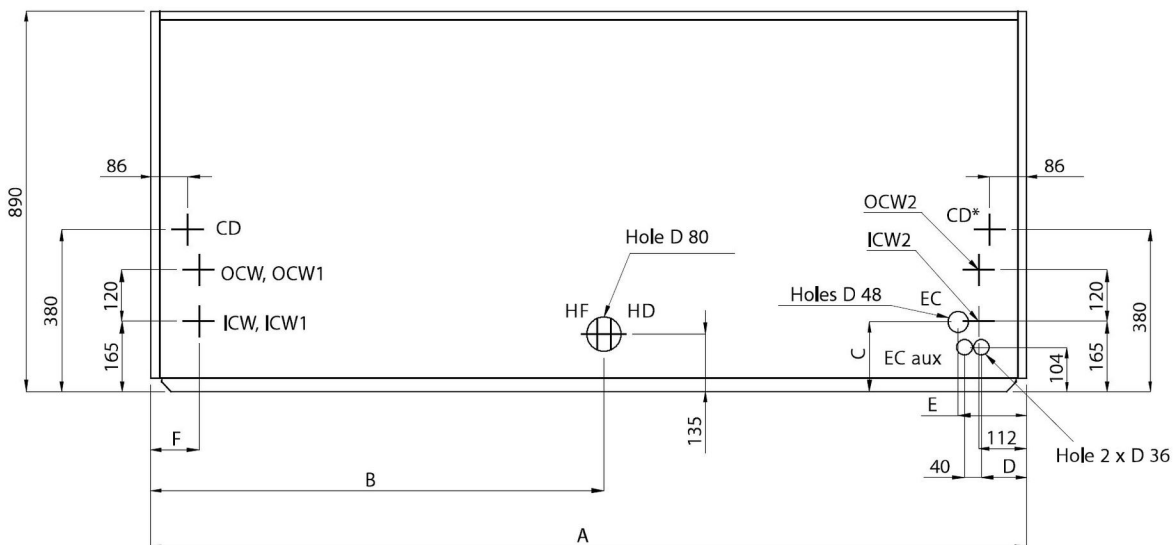

Tab. 2 - Downflow units, dimensions for Bottom, Top & Piping left Option

Unit Connection	PW025 PW030	PW035 PW040 PW046	PW045 PW060 PW066	PW070 PW080 PW091	PW095 PW100 PW136	PW145 PW161	PW170 PW201
Dimensions for Piping Bottom Option (Fig. 1.)							
A	844	1200	1750	2050	2550	2950	3350
B	95	235	910	1060	1565	1855	2385
C	125	160	160	160	150	150	150
D	140	105	105	105	150	150	150
E	100	120	120	120	115	115	115
F	76	112	112	112	112	112	112
Dimensions for Piping Top & Piping left Option (Fig. 2.)							
G	115	115	190	185	170	170	170
H	NA	135	135	135	120	120	120

NA = Not Available

Fig. 2. Downflow units, dimensions for Top & Piping left Option

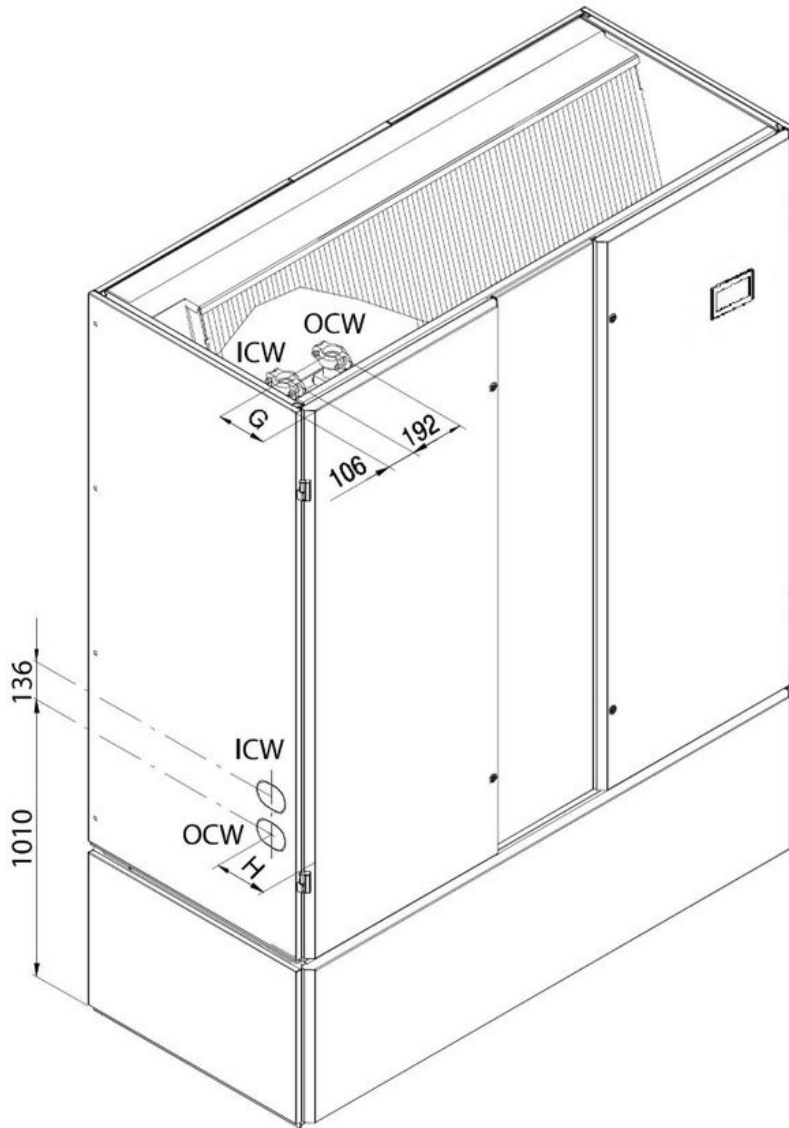

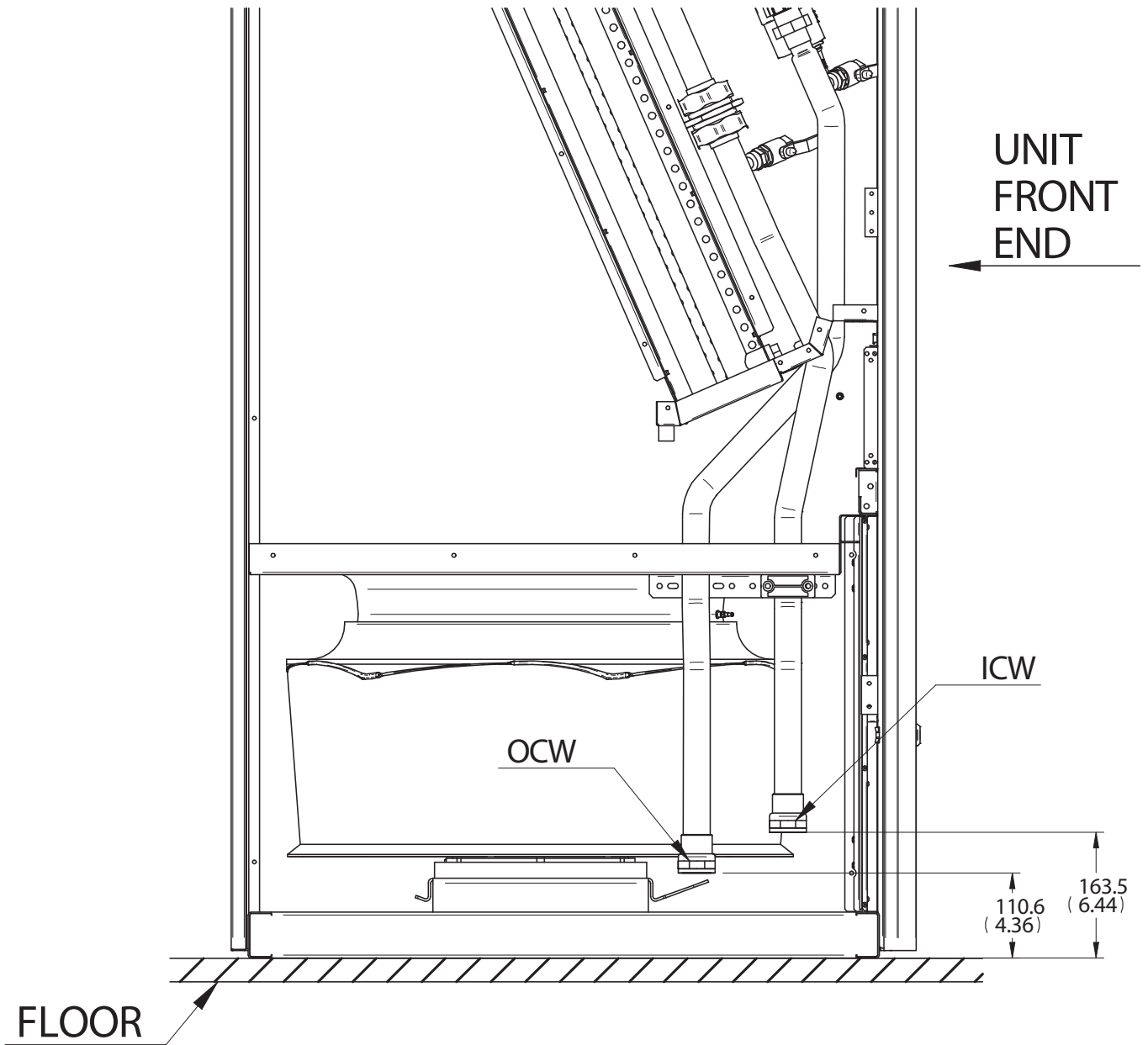

Bottom chilled water connections PW025-PW030 Downflow UP, side view

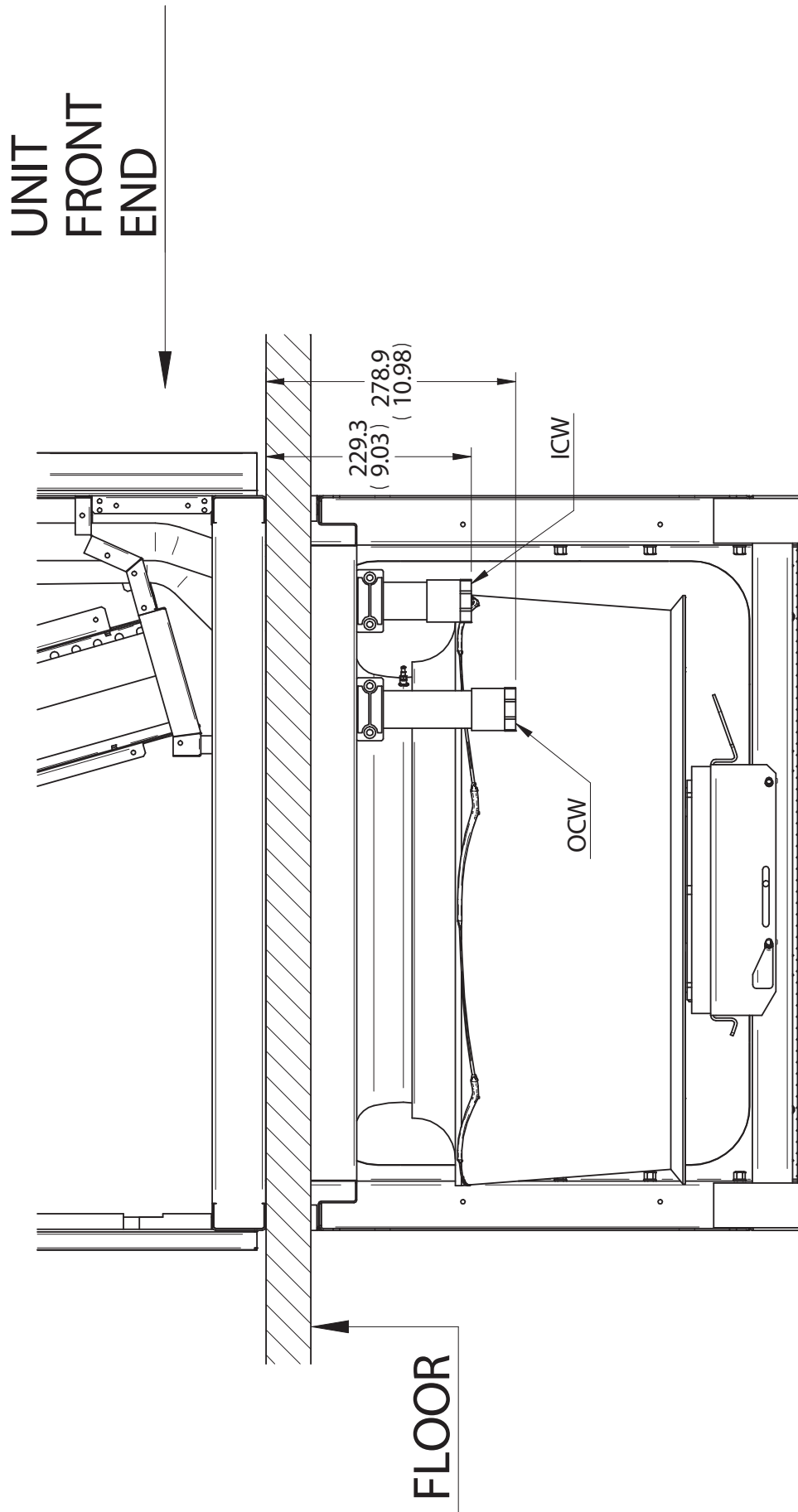

Bottom chilled water connections PW035-PW040-PW046-PW045-PW060-PW066-PW070-PW080-PW091 Downflow Down, side view

UNIT
FRONT
END

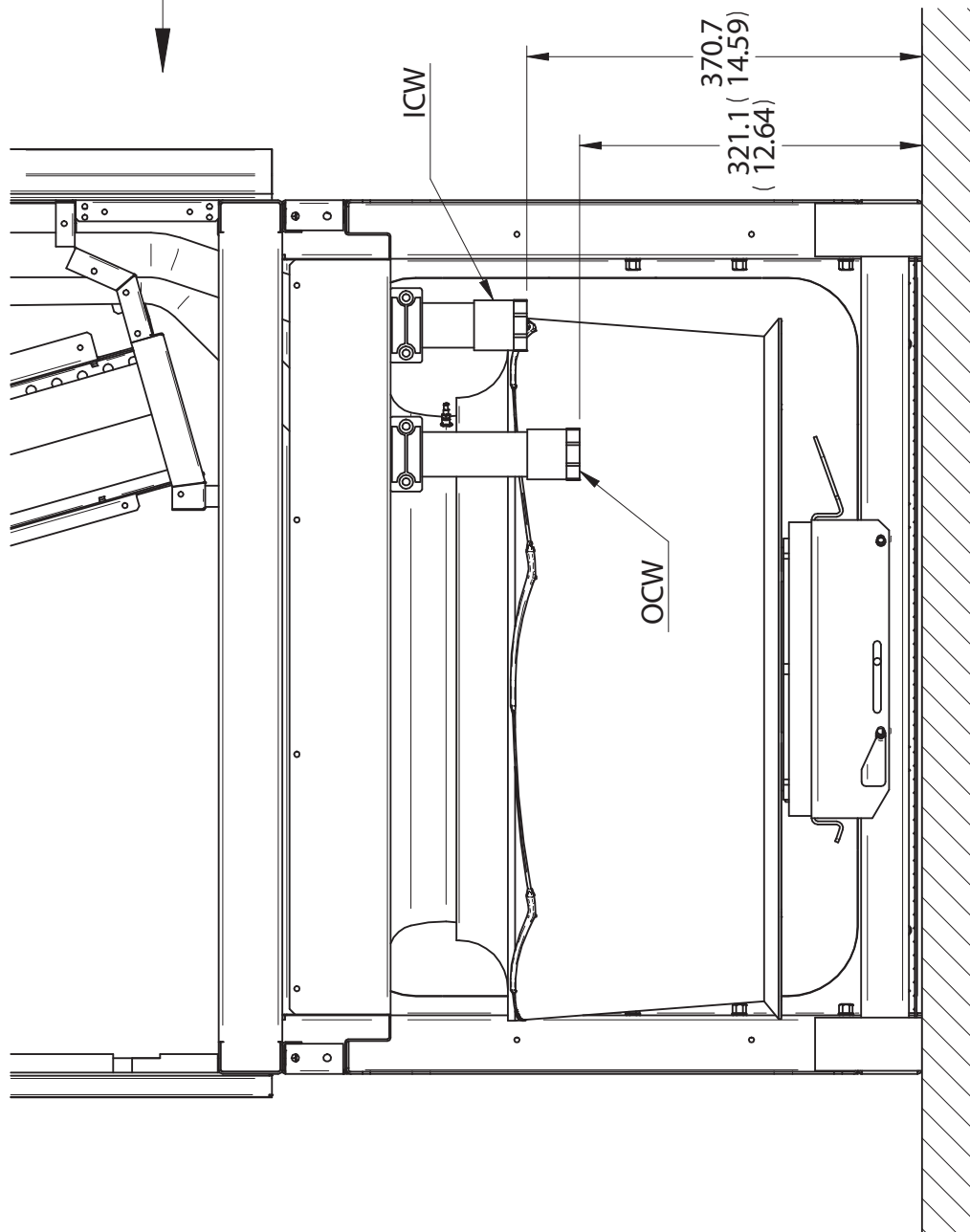

Bottom chilled water connections PW035-PW040-PW046-PW060-PW066-PW070-PW080-PW091 Downflow Up, side view

FLOOR

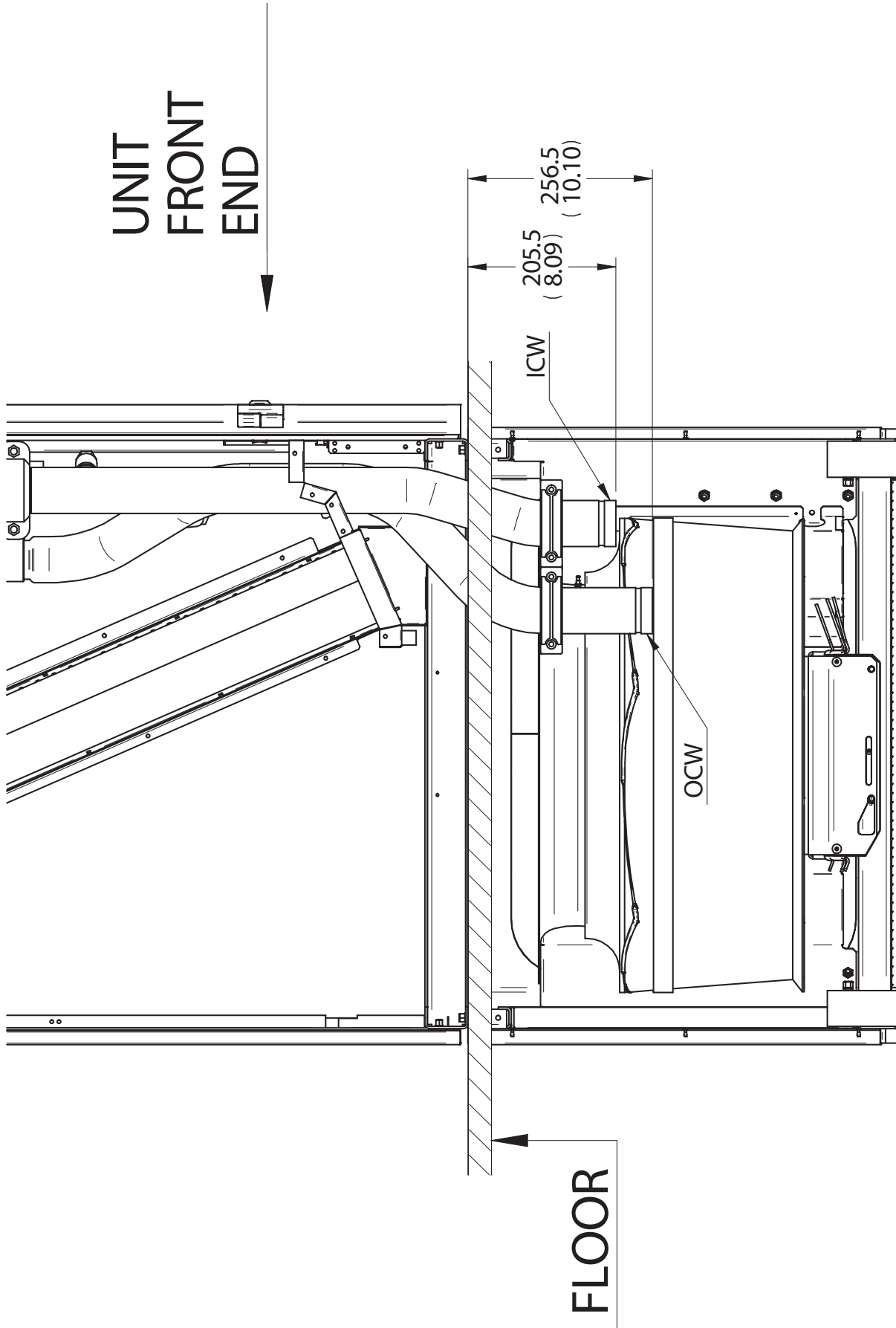

Bottom chilled water connections PW095-PW110-PW136-PW145-PW161-PW170-PW201
Downflow Down, side view

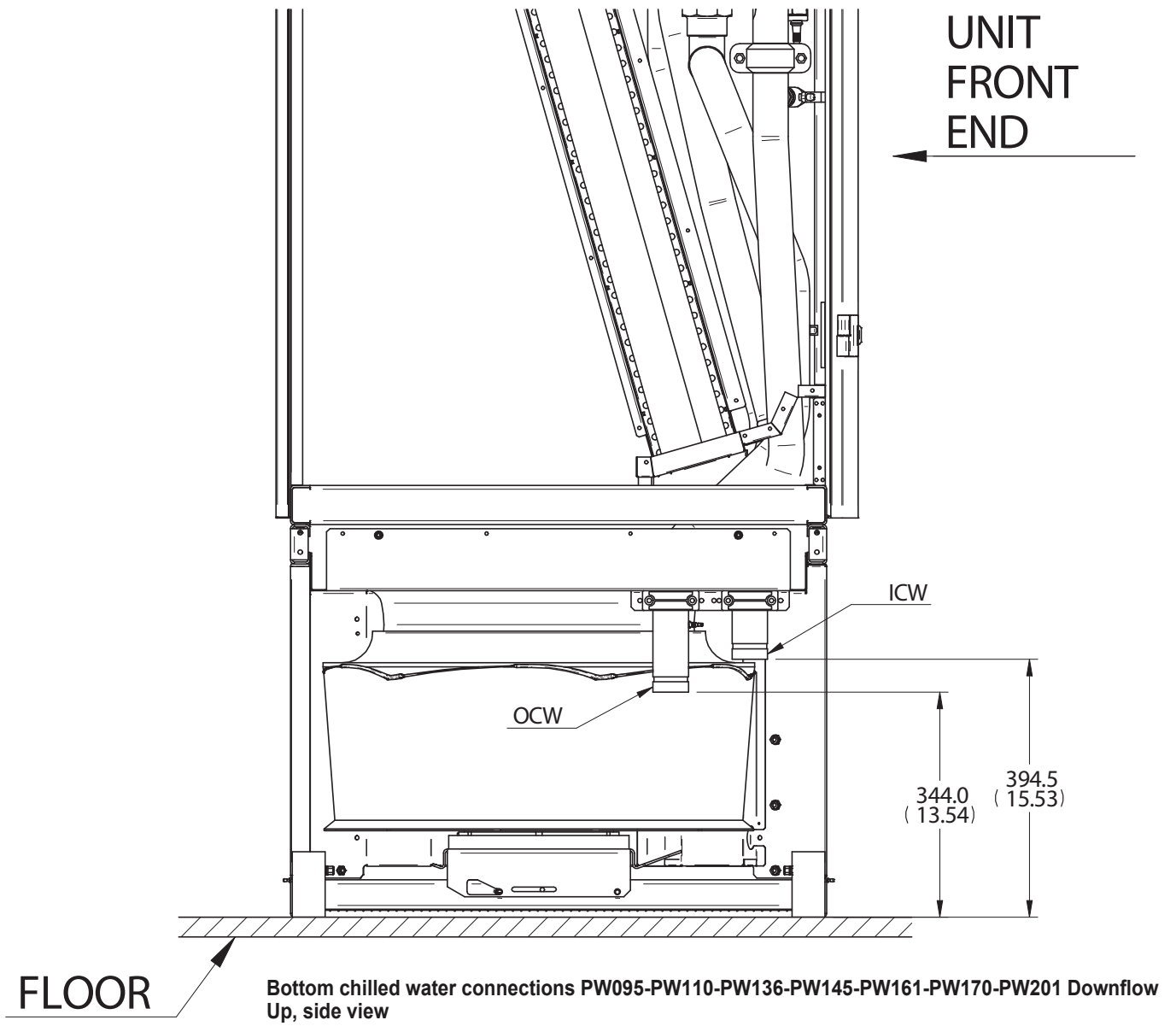

Top chilled water connections PW025-PW030-PW035-PW040-PW046-PW045-
PW060-PW066-PW070-PW080-PW091 Downflow Down and Downflow Up, side
view

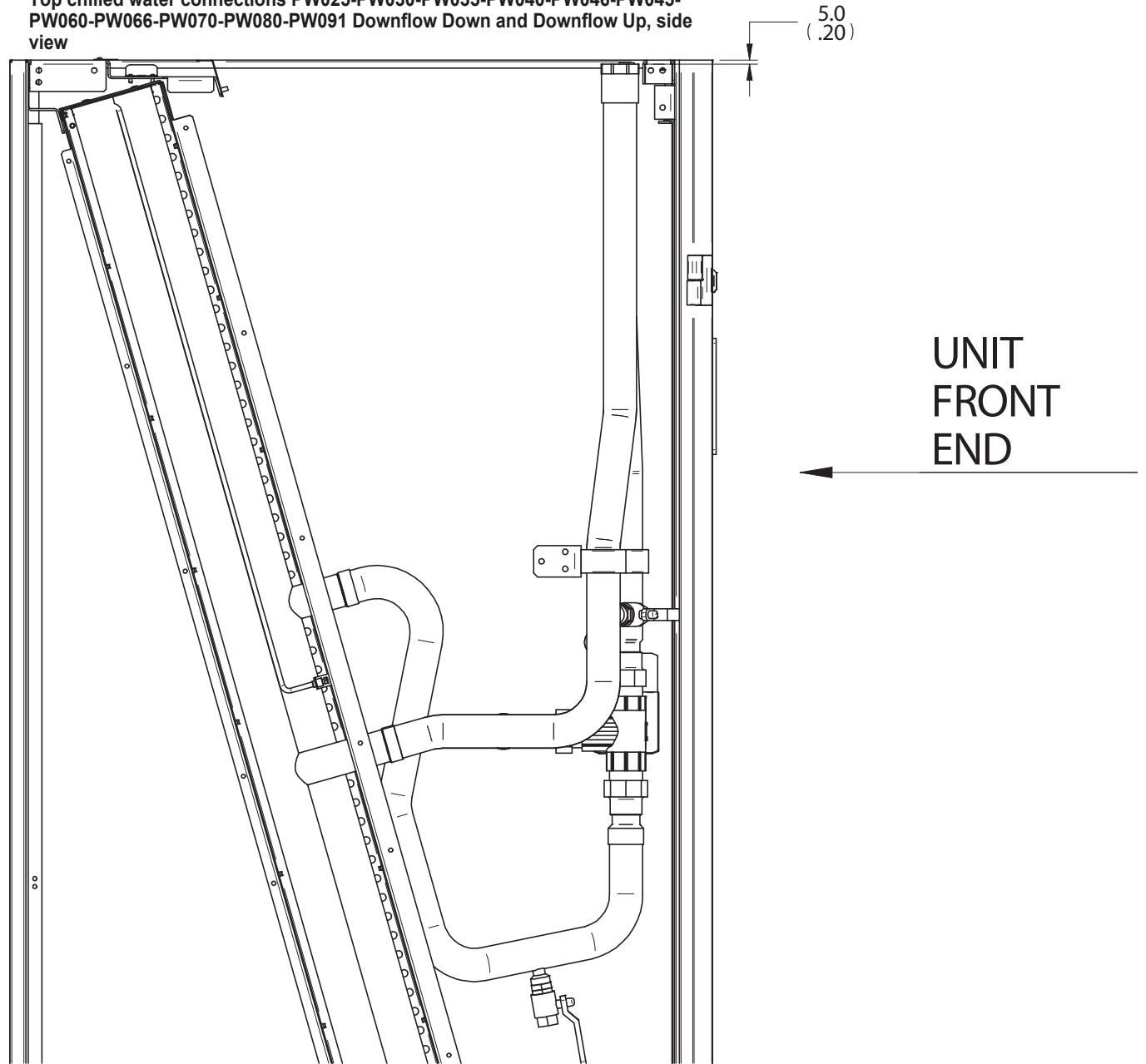

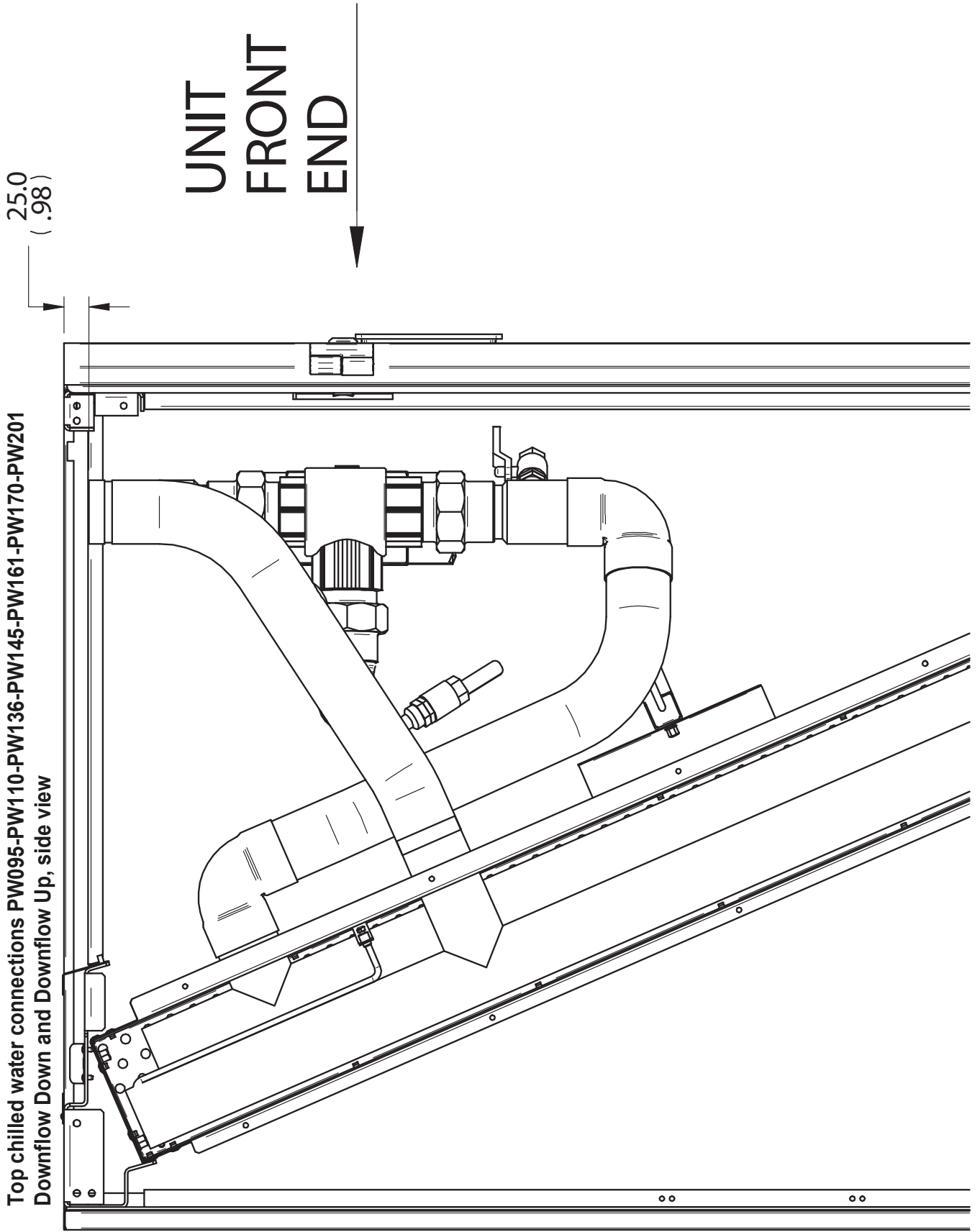

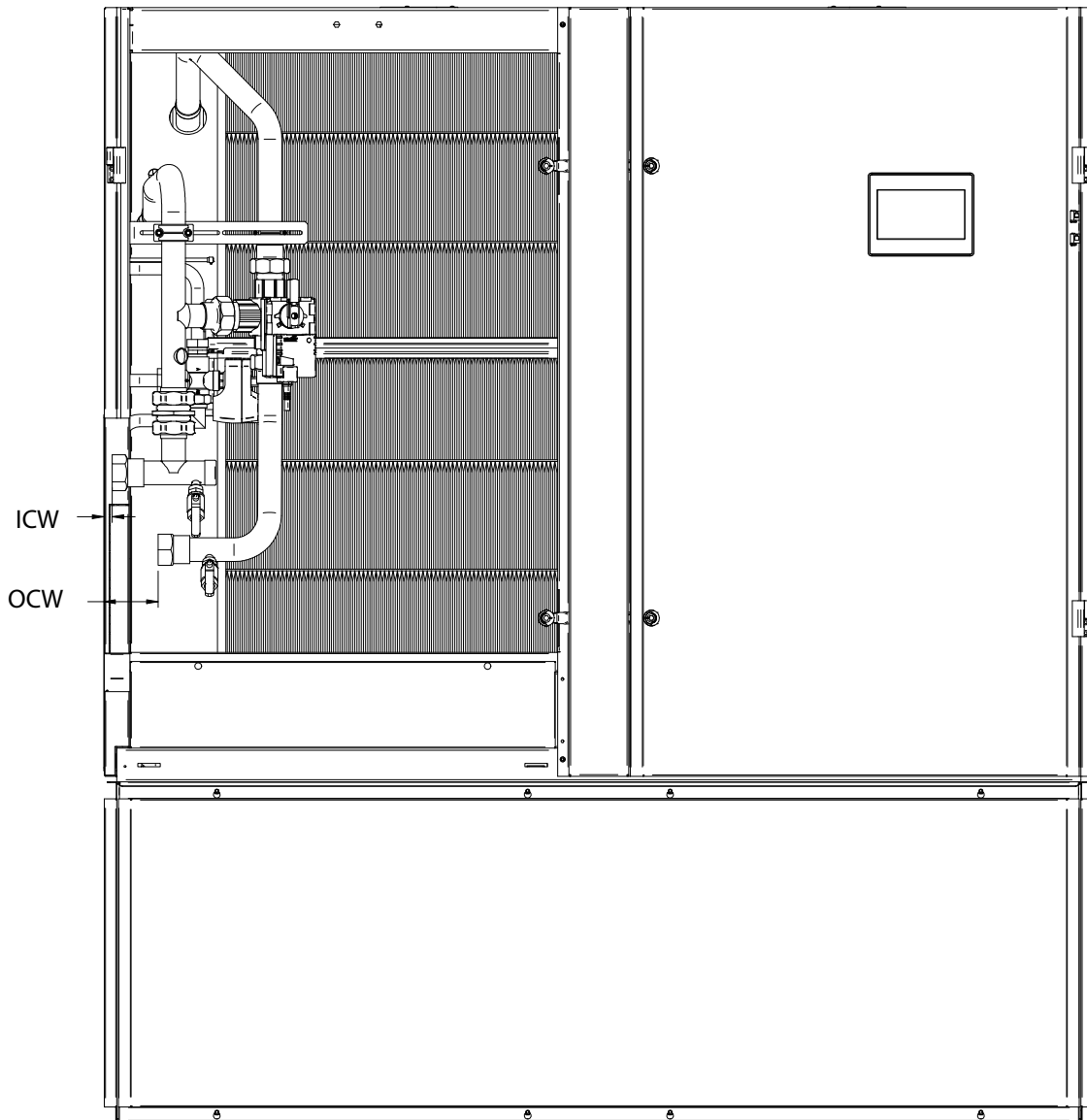

Downflow units	ICW	OCW
	[mm]	[mm]
Left chilled water connections PW035-PW040 Downflow Down and Downflow Up, side view	20	20
Left chilled water connections PW046 Downflow Down and Downflow Up, side view	20	69
Left chilled water connections PW045-PW060-PW066 Downflow Down and Downflow Up, side view	11	95
Left chilled water connections PW070-PW080-PW091 Downflow Down and Downflow Up, side view	41	100
Left chilled water connections PW095-PW110 Downflow Down and Downflow Up, side view	31	31
Left chilled water connections PW136-PW145-PW161-PW170-PW201 Downflow Down and Downflow Up, side view	31	80

Left chilled water connection - downflow units ; for all remaining dimensions - please refer to page 133

Tab. 3 - Hydraulic and electrical connections – Upflow versions

Unit Connection		PW025 PW030	PW035 PW040 PW046	PW045 PW060 PW066	PW070 PW080 PW091	PW095 PW110	Height from unit bottom [mm]
ICW	Chilled water inlet	Rp 1 ¼ - ISO 7/1	Rp 1 ¼ - ISO 7/1	Rp 1 ½ - ISO 7/1	O.D. Ø54 mm ** R 2- ISO7/1***	O.D. Ø64 mm ** R21/2 –ISO7/1***	334
OCW	Chilled water outlet	Rp 1 ¼ - ISO 7/1	Rp 1 ¼ - ISO 7/1	Rp 1 ½ - ISO 7/1	O.D. Ø54 mm ** R 2- ISO7/1***	O.D. Ø64 mm ** R21/2 –ISO7/1***	285
CD	Condensate drain	I.D. Ø20 [mm]					-
CD*	Condensate drain	I.D. Ø20 [mm]					-
HF	Humidifier feed	R ½ - ISO 7/1 (Electrode Humidifier), O.D. 6 [mm] (Infrared Humidifier)					-
HD	Humidifier drain	I.D. Ø32 [mm] (Electrode Humidifier), I.D. Ø22 [mm] (Infrared Humidifier)					-
EC	Electrical power supply	Ø 48 [mm]					-
EC aux	Low voltage cables	Ø 40 - Ø 36 [mm]					-

CD* only for unit from PH095 toPH110

** Grooved Connection.

*** Optional. Threaded union on request

Tab. 3 - Hydraulic and electrical connections – Upflow versions

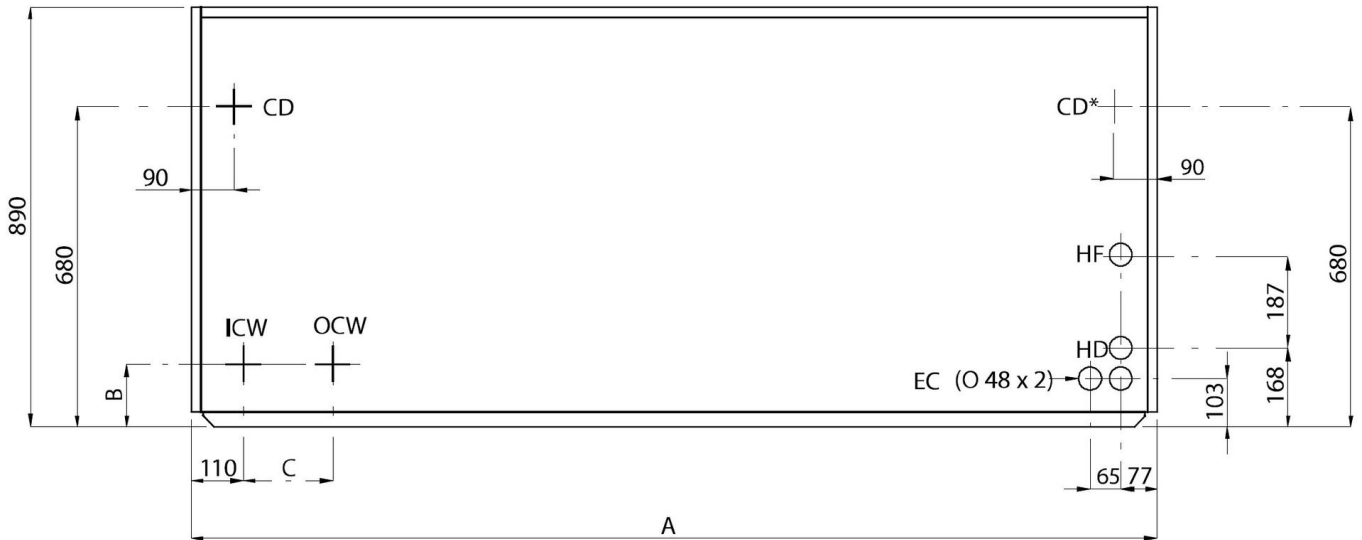

Tab. 4 - Upflow unit, Dimensions for Piping Bottom, Top & Piping left Option

Unit Connection	PW025 PW030	PW035 PW040 PW046	PW045 PW060 PW066	PW070 PW080 PW091	PW095 PW110
Dimensions for Piping Bottom Option (Fig. 3.)					
A	844	1200	1750	2050	2550
B	130	135	135	135	135
C	90	190	190	190	190
Dimensions for Piping Top & Piping left Option (Fig. 4.)					
D	NA	135	135	120	120

NA = Not Available

Fig. 4. Upflow unit, Dimensions for Piping Top & Piping left Option

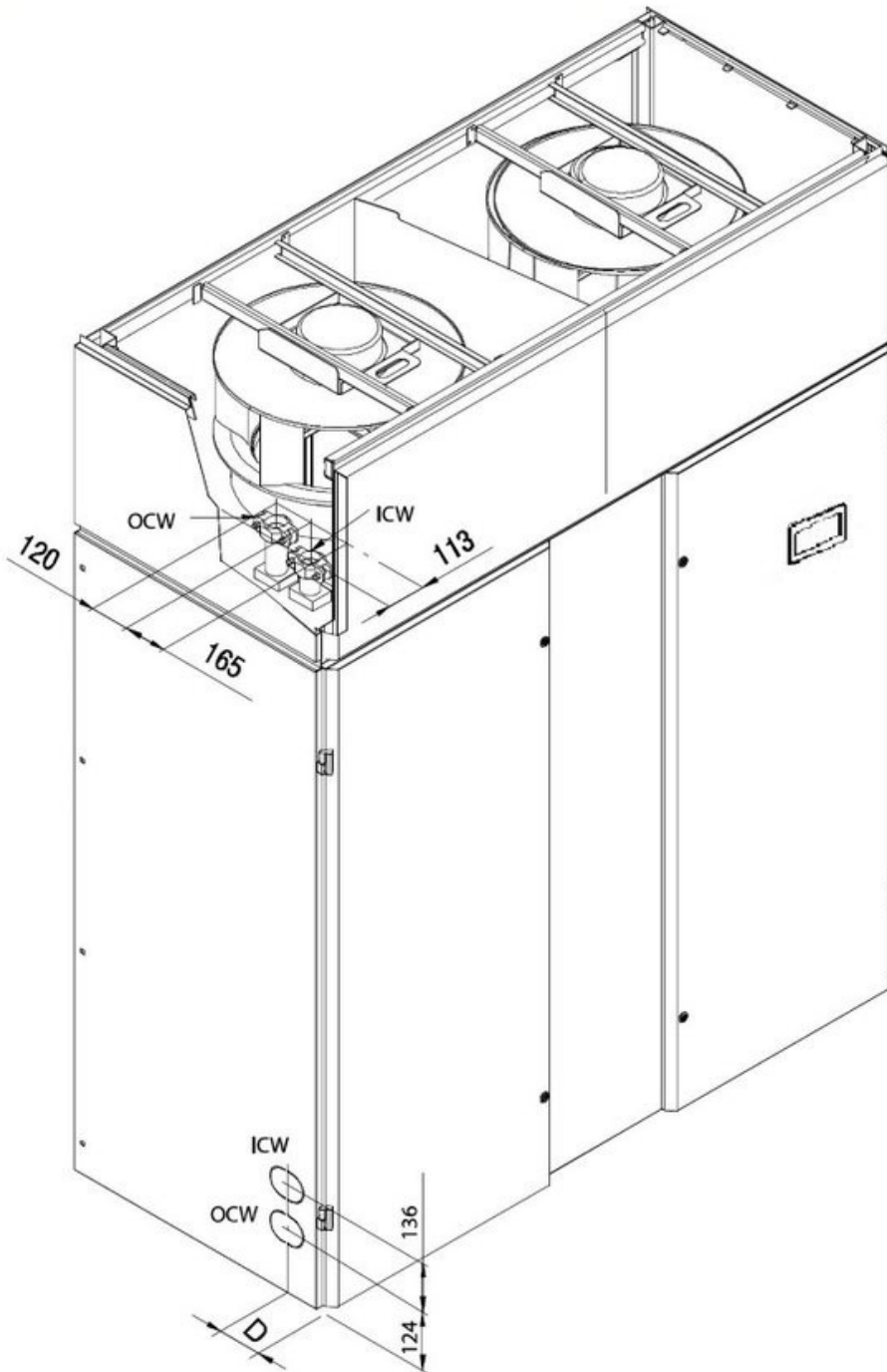

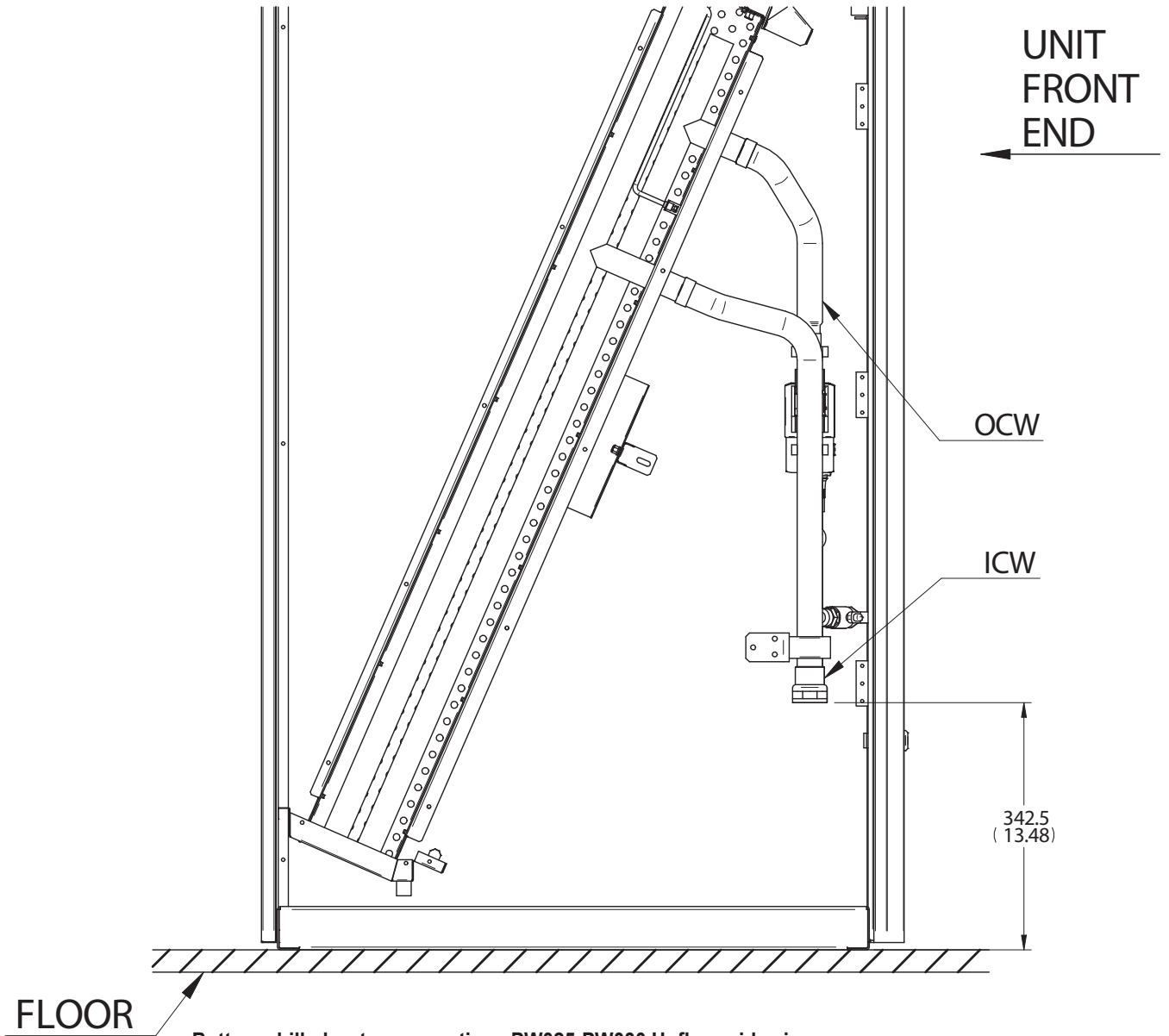

UNIT
FRONT
END

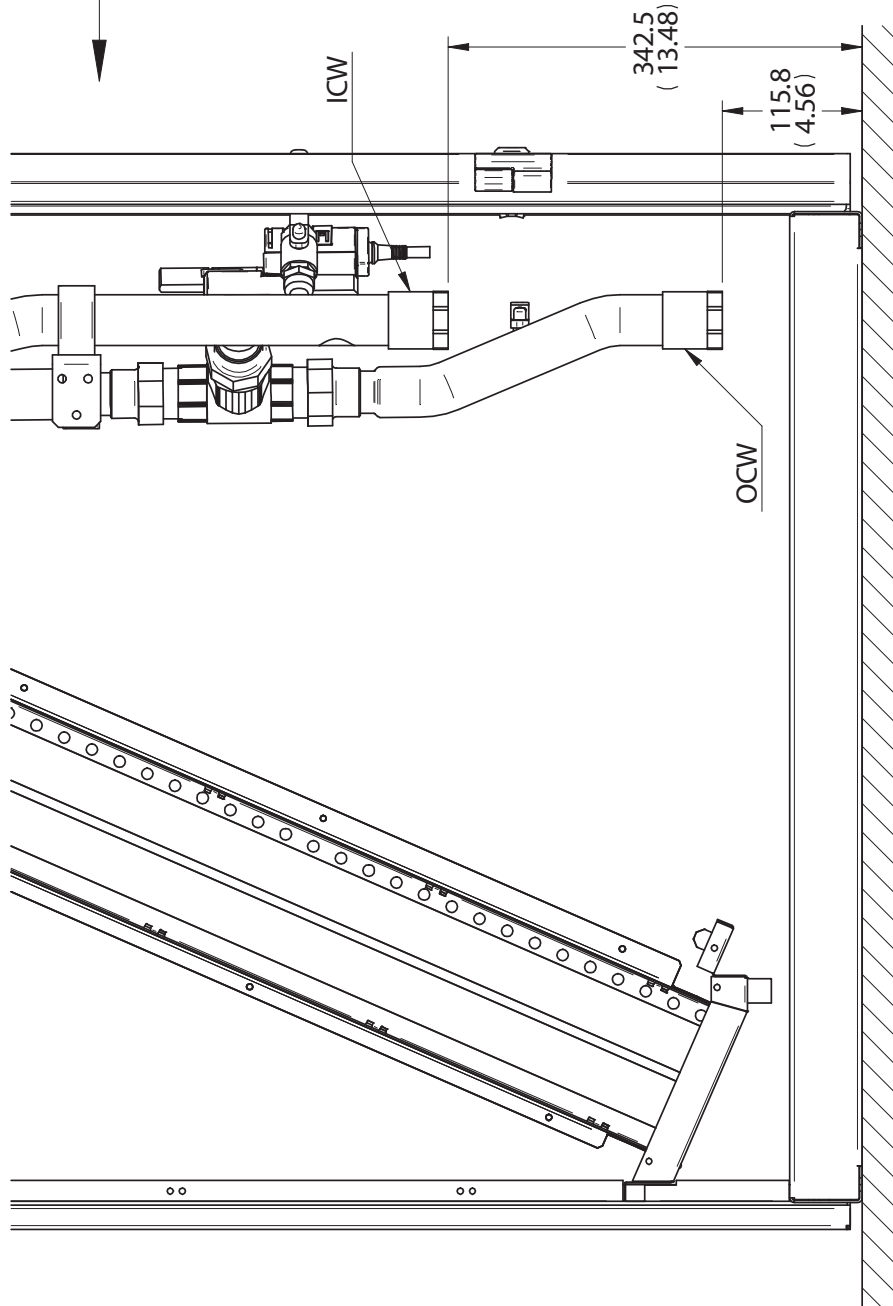

Bottom chilled water connections PW035-PW040 Upflow, side view

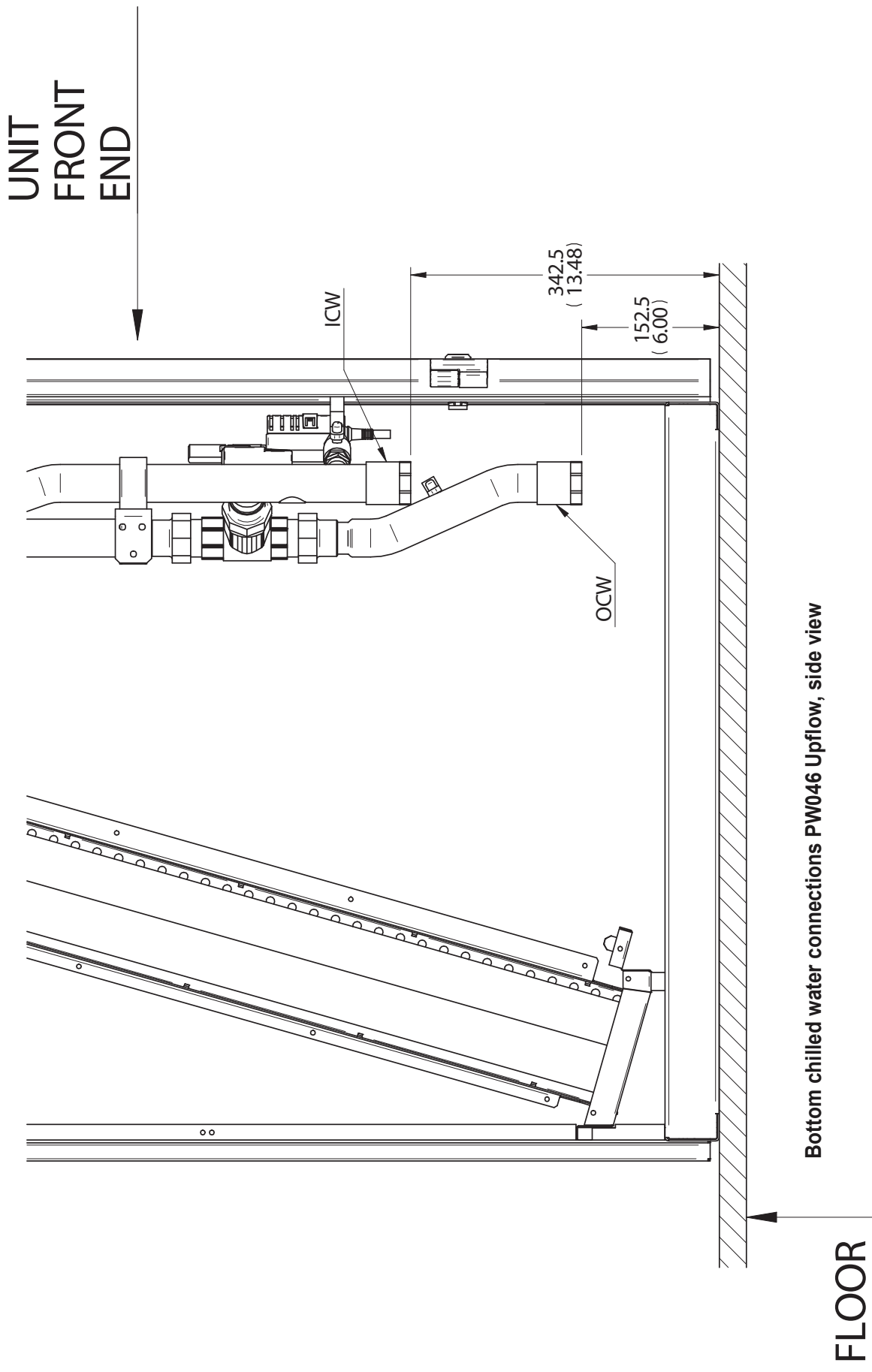

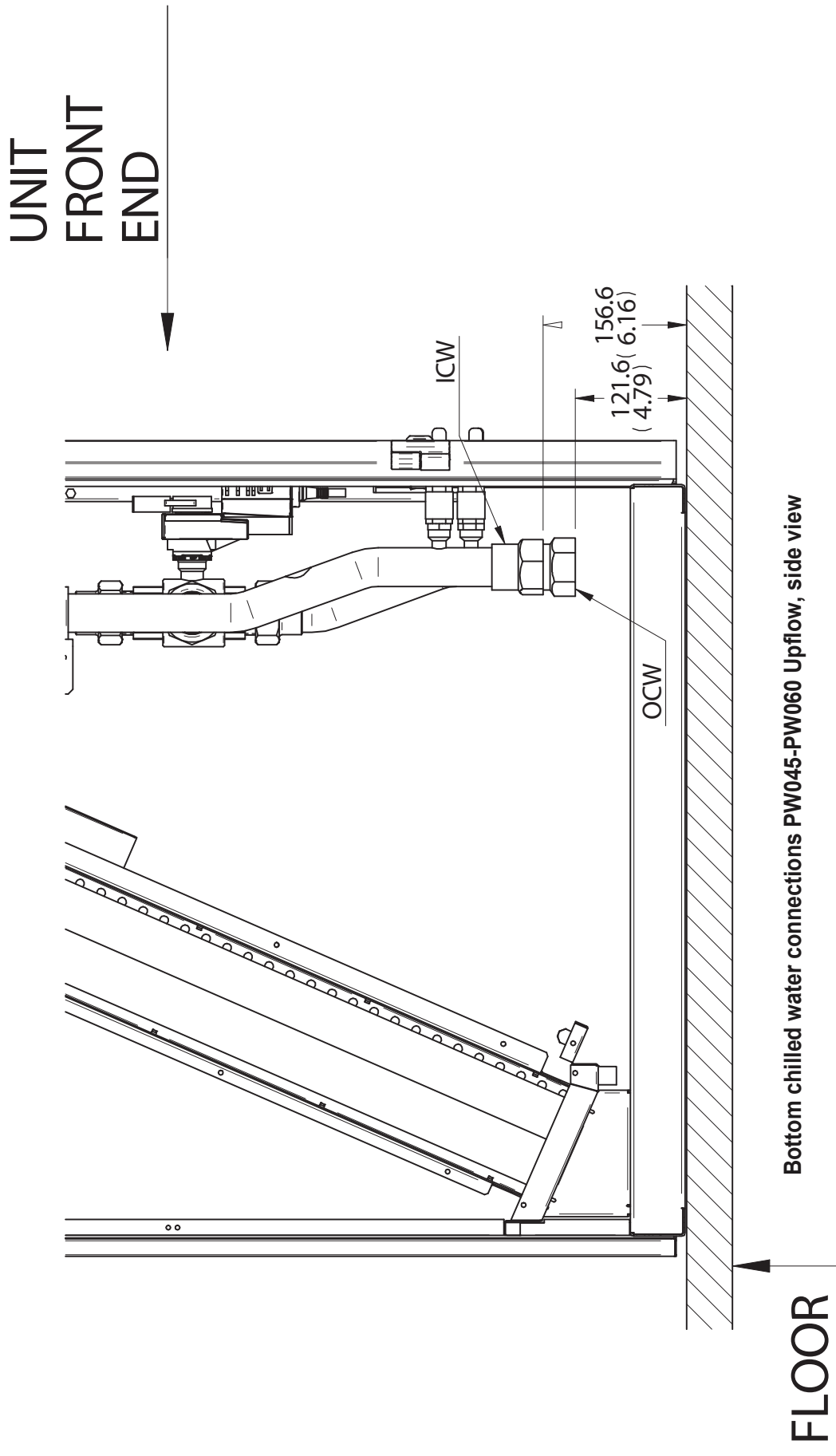

UNIT
FRONT
END

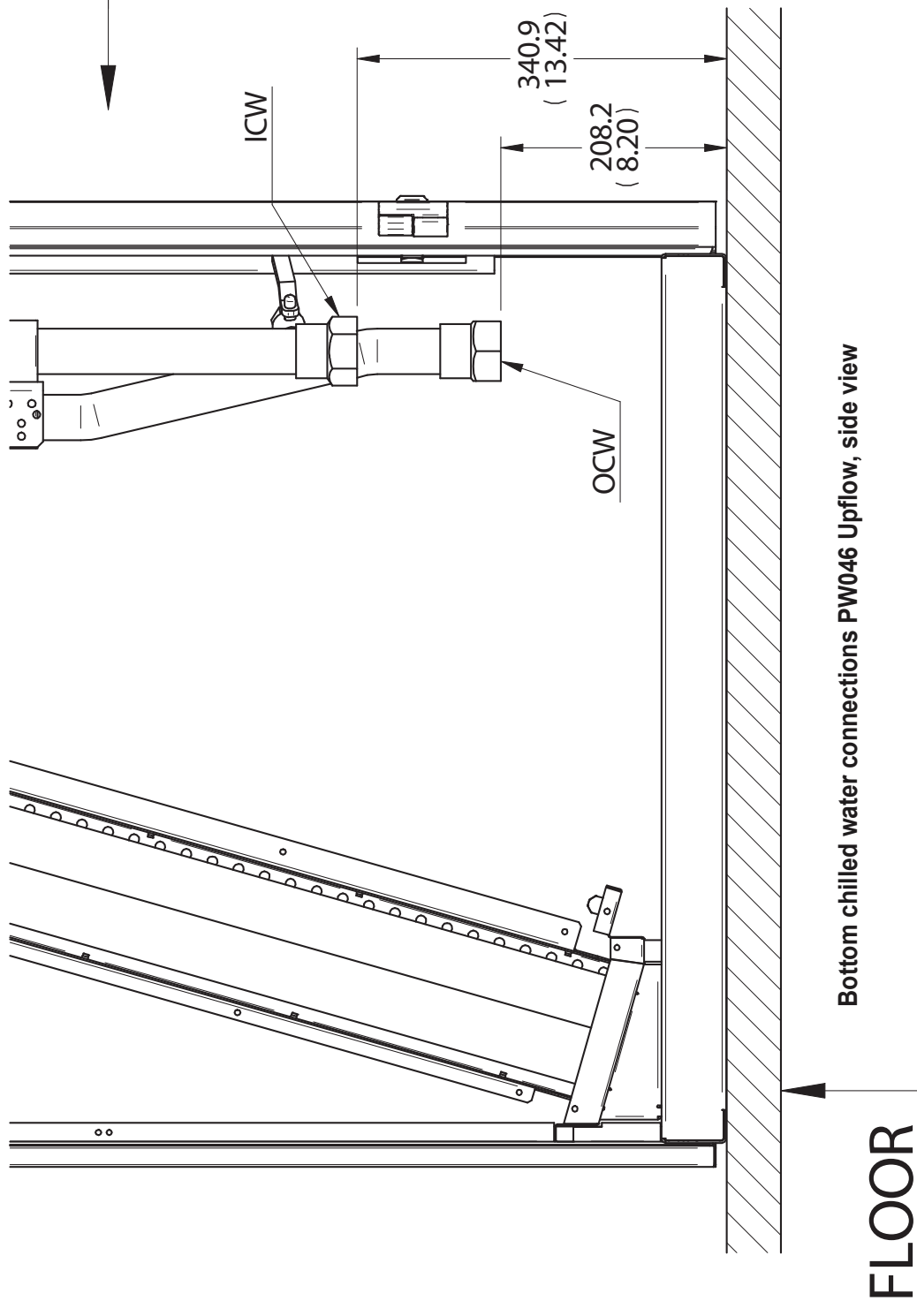

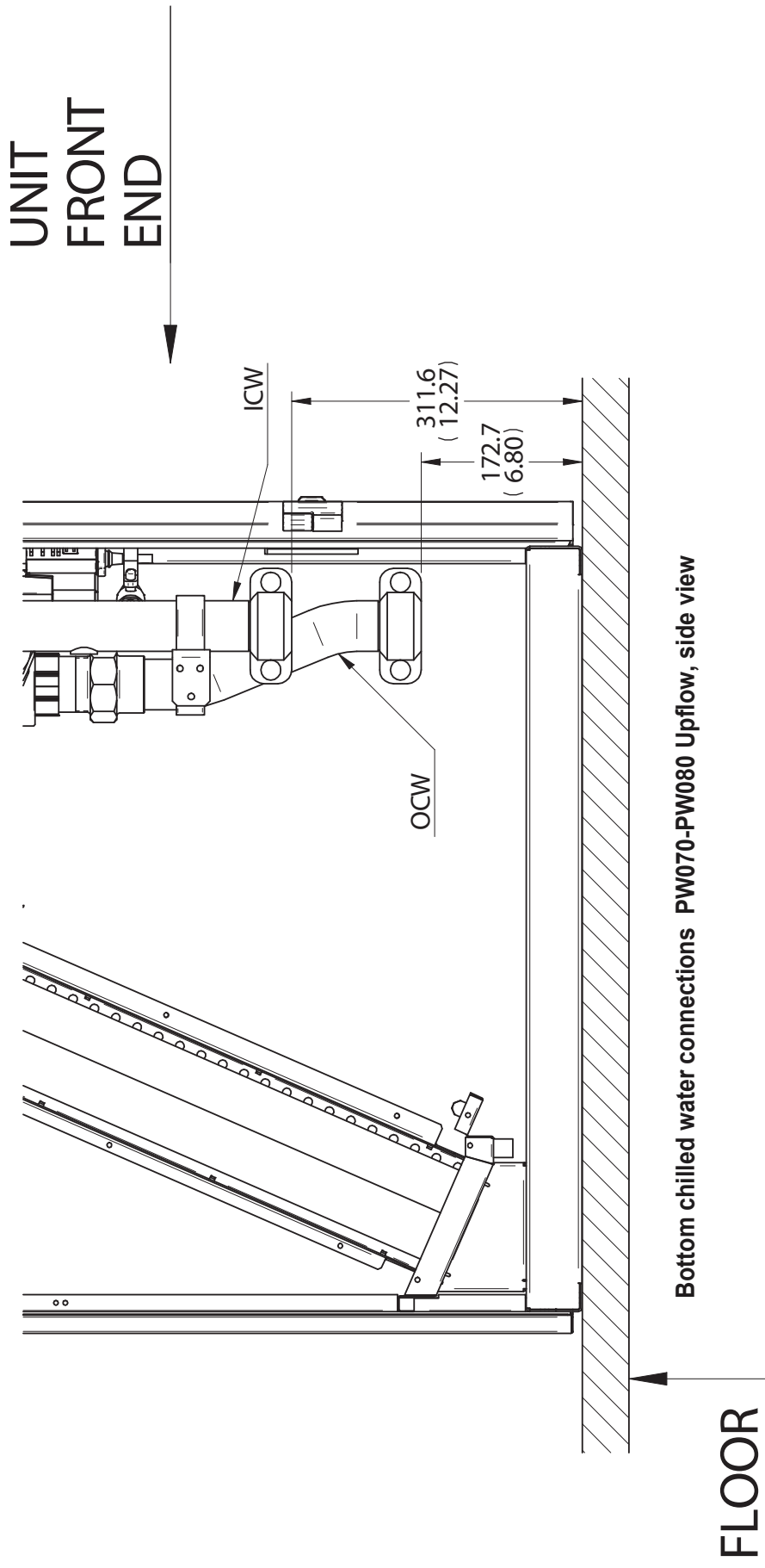

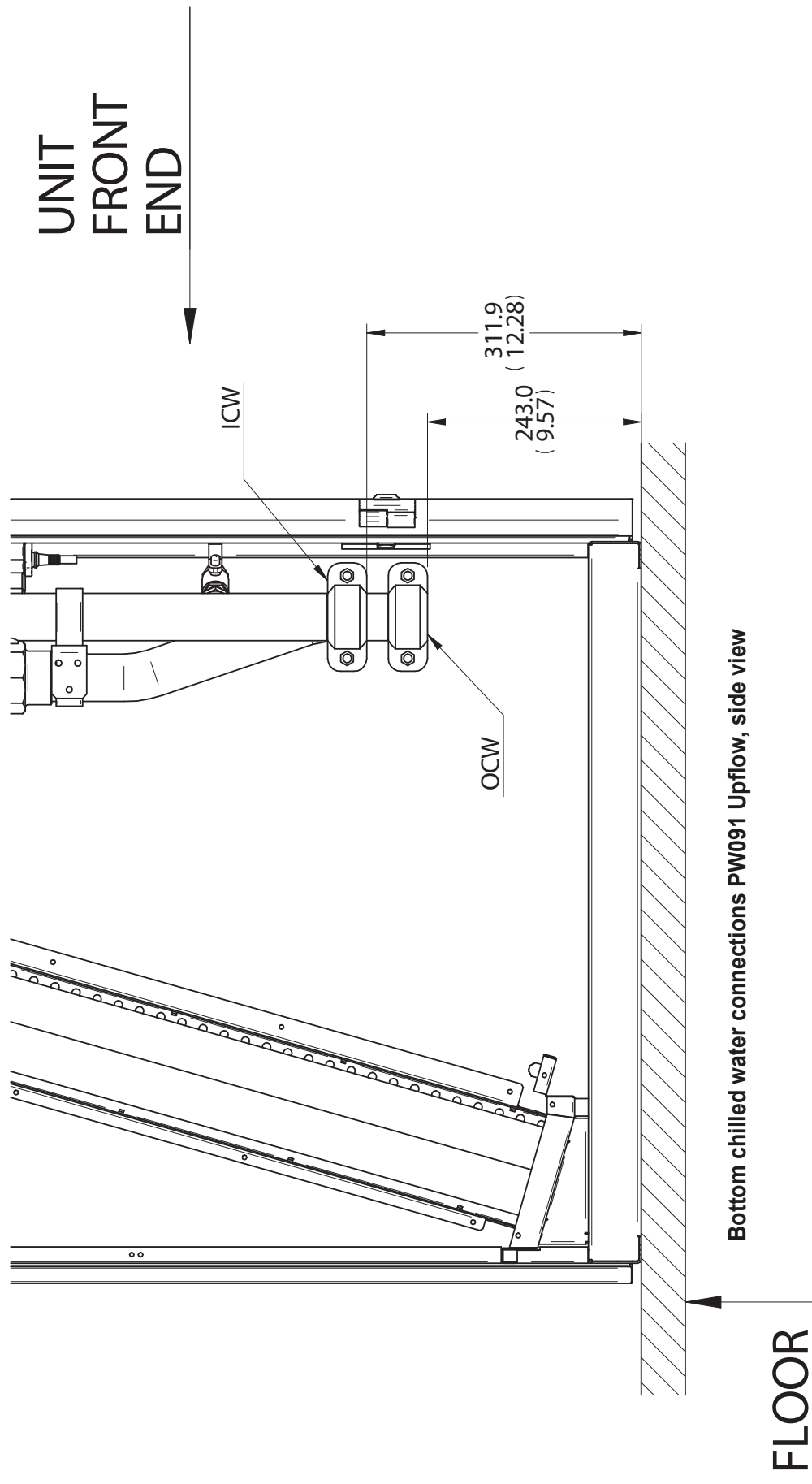

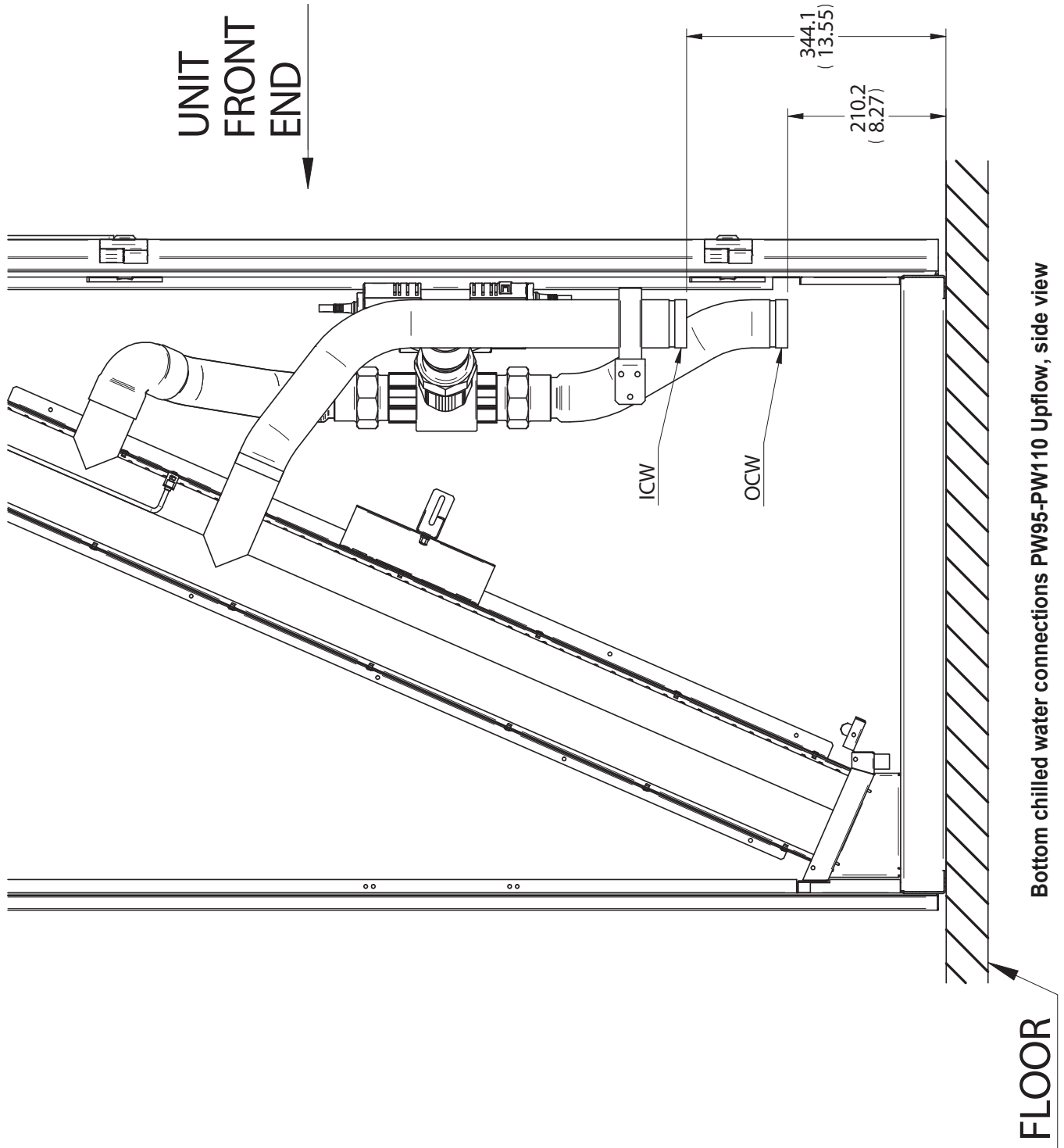

Top chilled water connections PW035-PW040-PW046-PW045-PW060-PW066-PW070-PW080-PW091 Upflow, side view

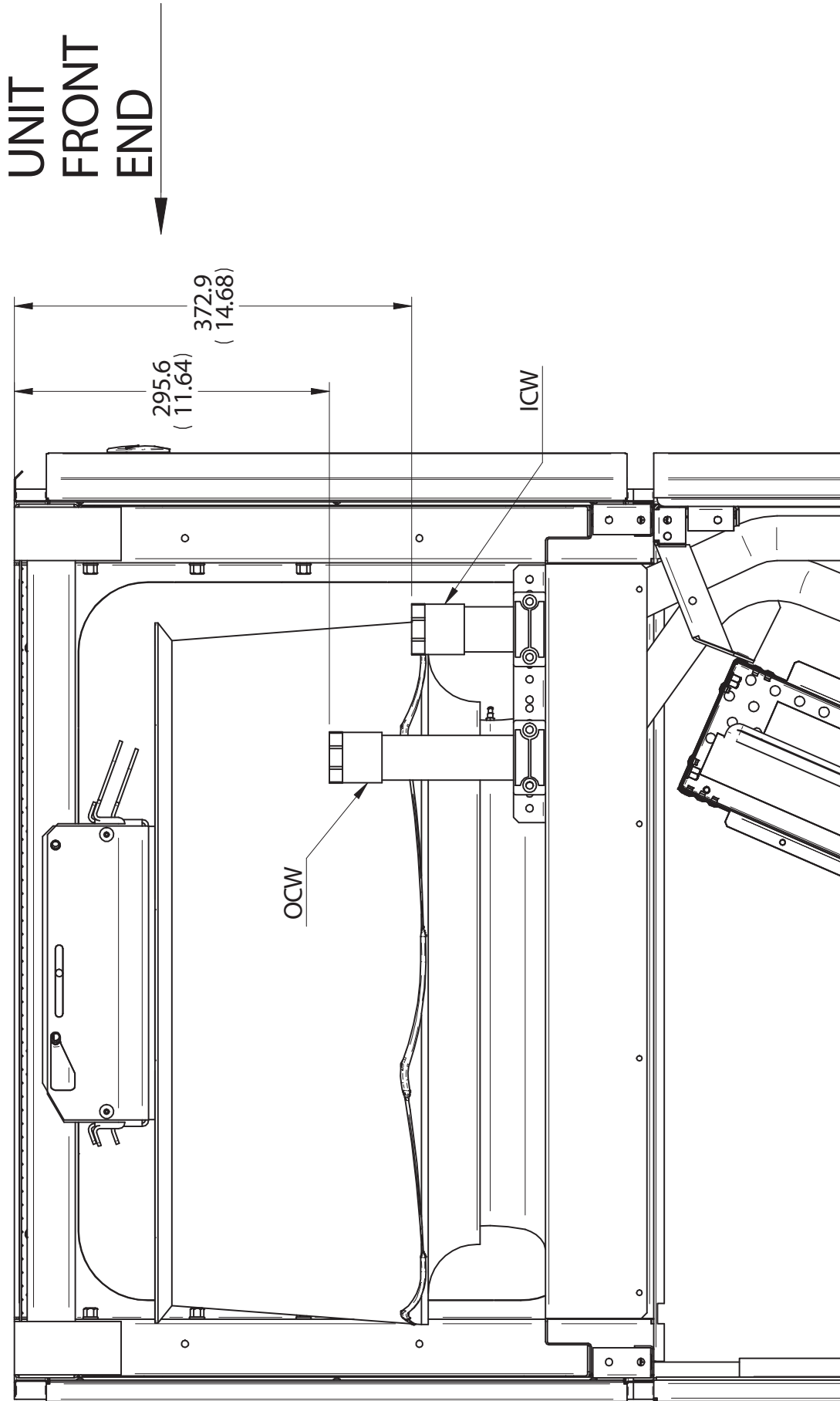

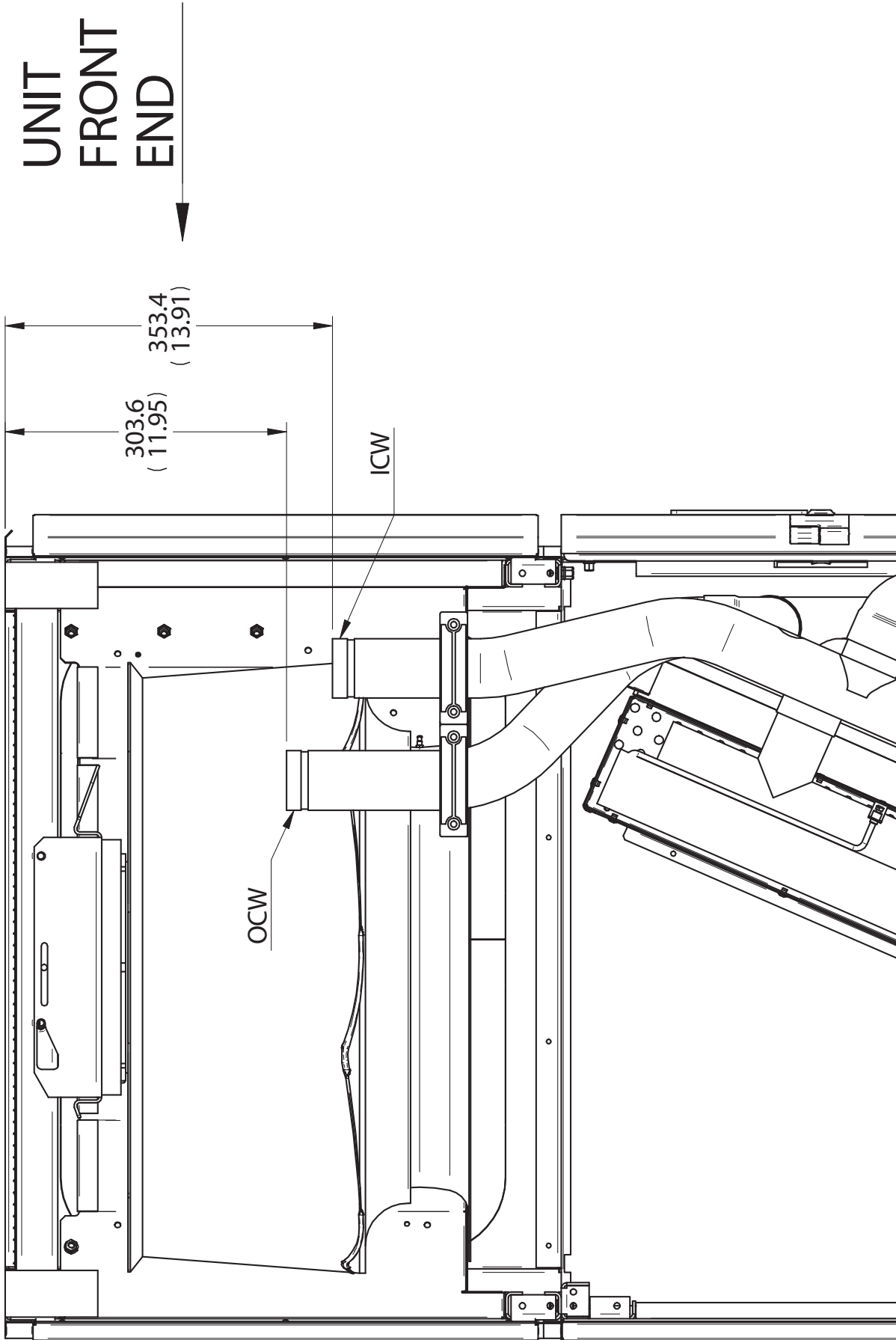

Top chilled water connections PW95-PW100-PW110 Upflow, side view

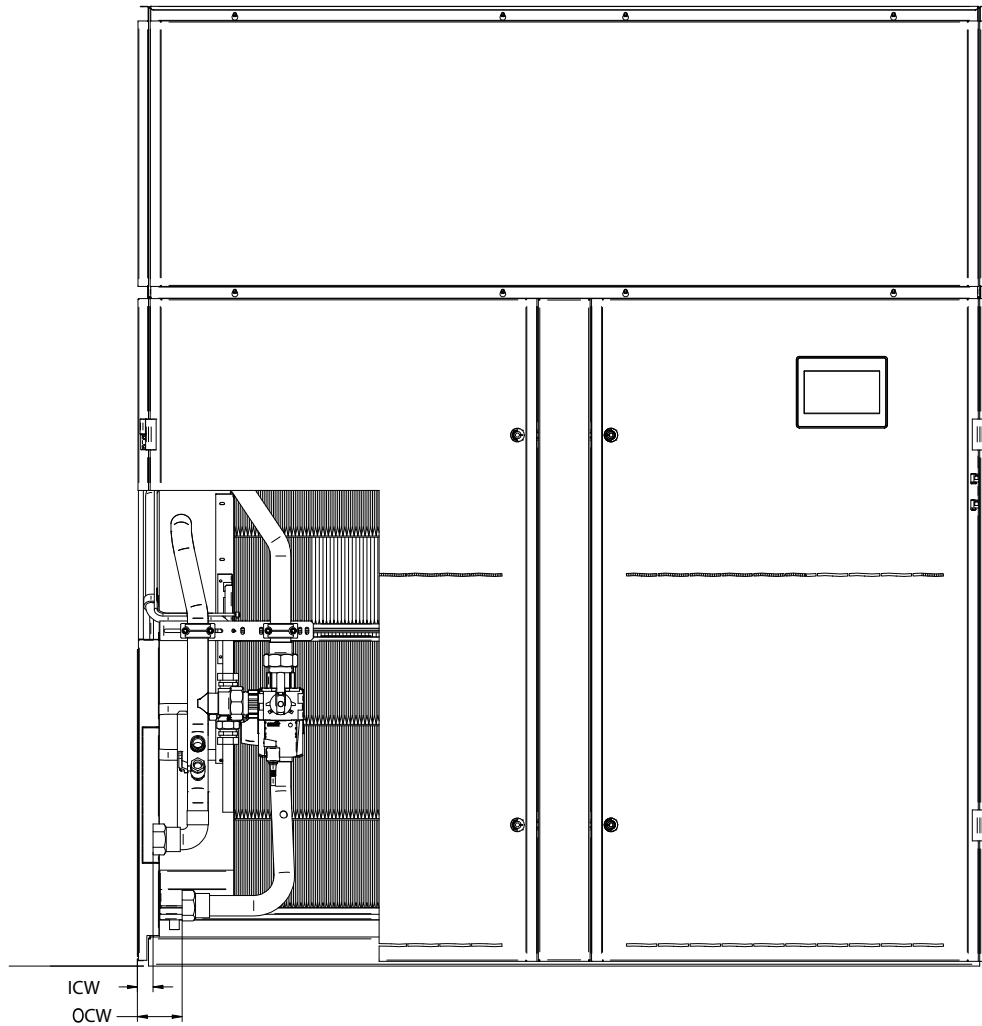

Upflow units	ICW	OCW
	[mm]	[mm]
Left chilled water connections PW035-PW040-PW046-PW45-PW060-PW0664 Upflow, side view	21	95
Left chilled water connections PW070-PW080-PW091 Upflow, side view	41	100
Left chilled water connections PW95-PW100-PW110 Upflow, side view	31	31

Left chilled water connection, Upflow units, for all remaining dimensions - please refer to page XXXX

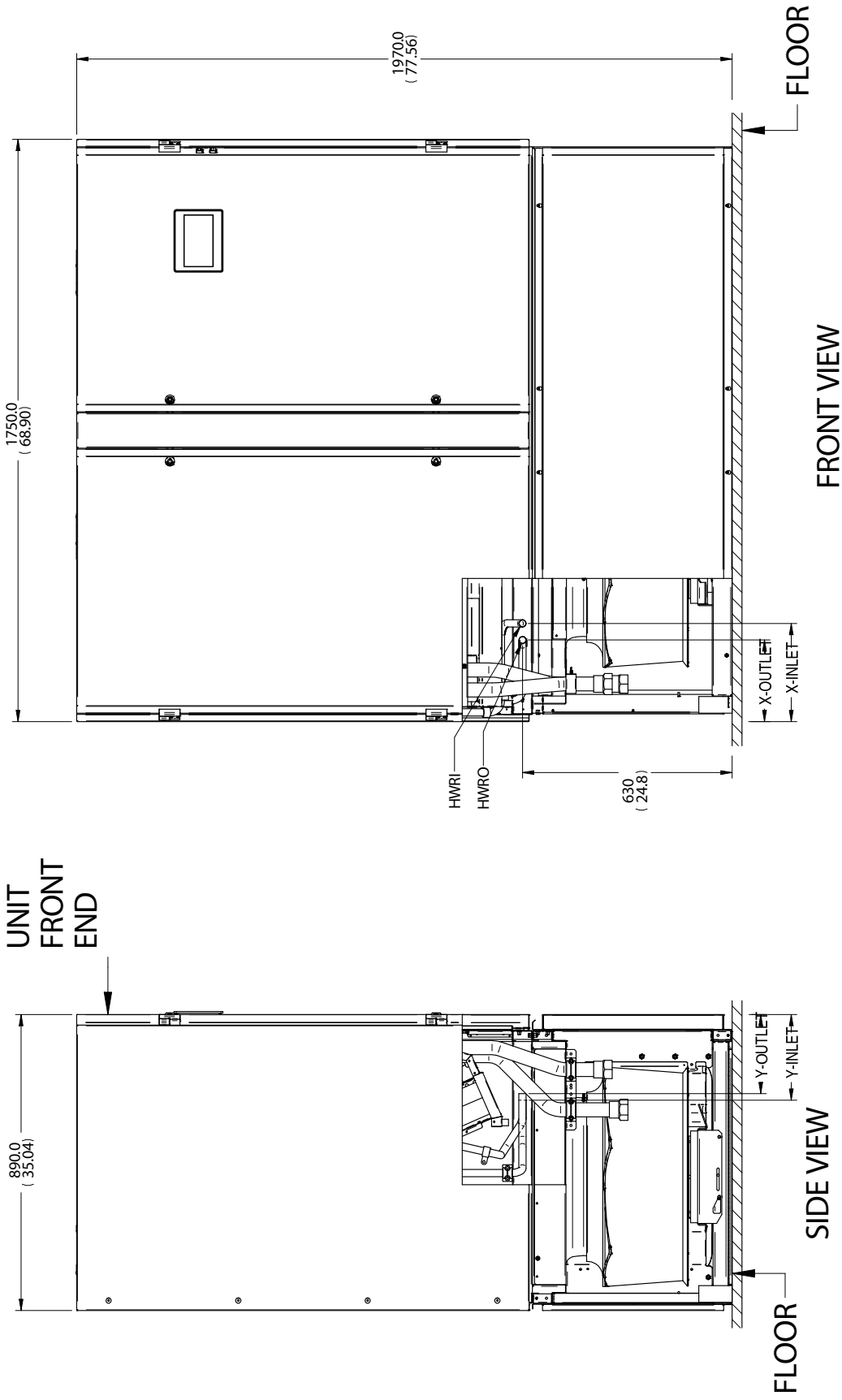

1. PCW SIZE 3 (PW060) SHOWN ON DRAWING.
2. ALL DIMENSIONS MEASURED FROM FRONT LEFT CORNER OF UNIT INCLUDING PANELS AND HAVE A TOLERANCE OF 13 MM (1/2").
3. HOT WATER HEATING CONNECTIONS ARE O. D. 22 MM (0.87") COPPER.
4. SOME PARTS NOT SHOWN FOR CLARITY.
5. ICW - CHILLED WATER INLET (SINGLE CHILLED WATER CIRCUIT).
OCW - CHILLED WATER OUTLET (SINGLE CHILLED WATER CIRCUIT).

PCW STANDARD & EXTENDED HEIGHT DOWNFLOW HOT WATER REHEATING				
SIZE	POINT	X (MM)	Y (MM)	Z (MM)
ALL SIZES	HWRI	302	258	3
	HWRO	245	238	

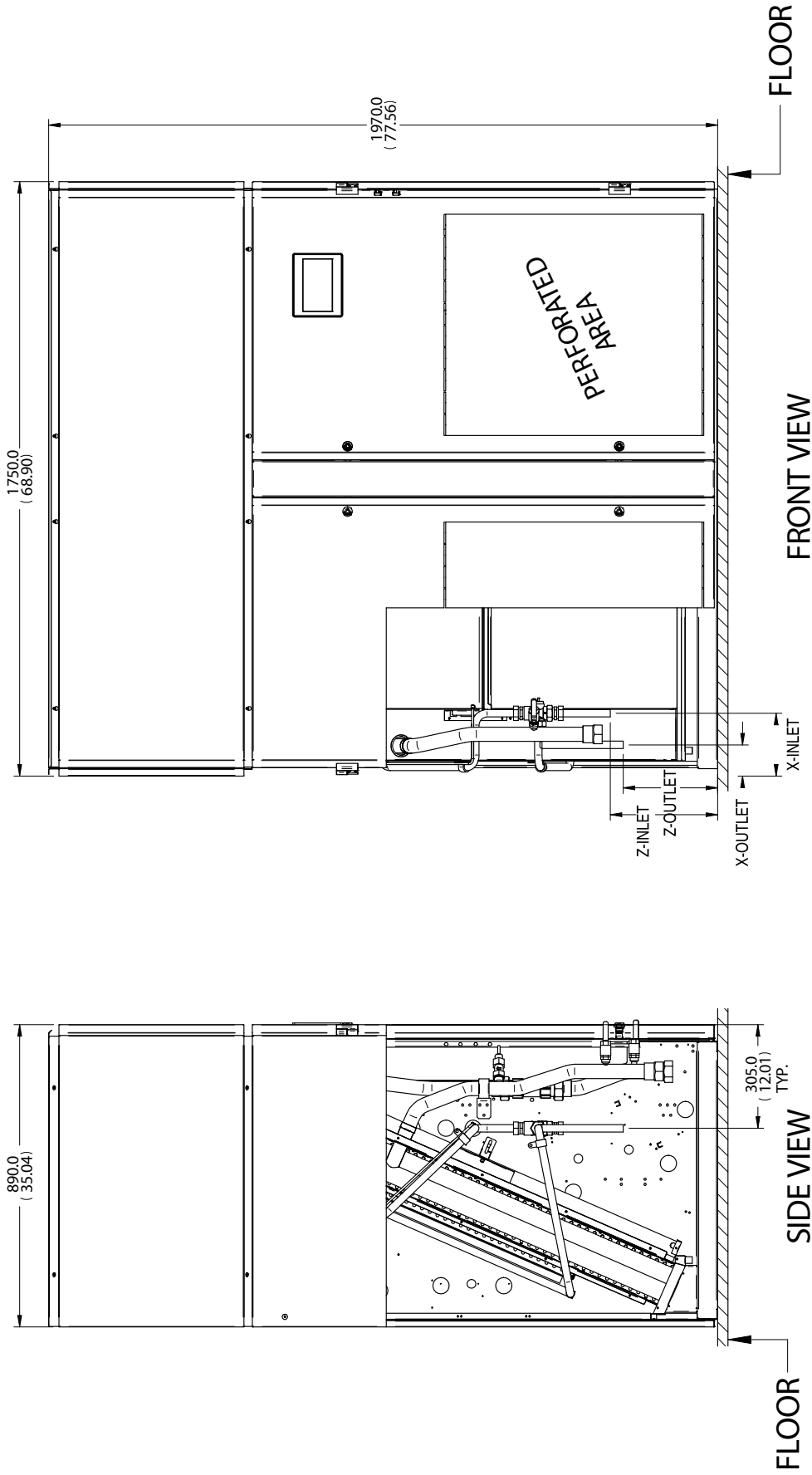

1. PCW SIZE 3 (PW060) SHOWN ON DRAWING.

2. ALL DIMENSIONS MEASURED FROM FRONT LEFT CORNER OF UNIT INCLUDING PANELS AND HAVE A TOLERANCE OF 13 MM (1/2").

3. HOT WATER REHEATING CONNECTIONS ARE O. D. 22 MM (0.87") COPPER.

4. SOME PARTS NOT SHOWN FOR CLARITY.

5. ICW - CHILLED WATER INLET (SINGLE CHILLED WATER CIRCUIT),
OCW - CHILLED WATER OUTLET (SINGLE CHILLED WATER CIRCUIT).

PCW STANDARD & EXTENDED HEIGHT UPFLOW HOT WATER REHEATING				
SIZE	POINT	X (MM)	Y (MM)	Z (MM)
ALL SIZES	HWRI	185	305	
	HWRO	92	305	

Annex E - Accessories

Content

1 - Overview.....	157	11 - Air economizer.....	162
2 - Legs kit.....	158	12 - Floor tiles support kit.....	163
3 - Base frame.....	158	13 - Fans maintenance kit.....	163
4 - Base module.....	158	14 - Plenum with display.....	164
5 - Base module 600/300 mm high with rear air intake.....	159	15 - Leak Detector - Liquistat.....	164
6 - Fresh air module.....	159	16 - Flange Connection.....	165
7 - Vertical flow extension hood.....	160	17 - Smoke/Fire detector.....	165
8 - Hood with high efficiency air filter.....	160	18 - Plenum with damper.....	165
9 - Plenum with silencing cartridges.....	161	19 - System Display.....	166
10 - Horizontal hood with grid.....	161		

1 - Overview

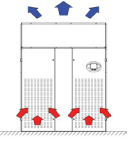
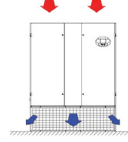
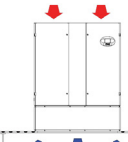
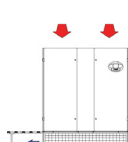
Accessory	Purpose	Position	U - Upflow	H - Downflow Frontal	D - Downflow Up	E - Downflow Down
						
Legs kit	Support	Bottom	NO	NO	YES	YES
Base frame	Support	Bottom	NO	NO	YES	YES
Base module	Support + piping lay-down	Bottom	YES	NO	NO	NO
Base module 600/300 mm high with rear/bottom air intake	Air flow	Bottom	YES	NO	NO	NO
Fresh air module	Air flow	Fan inlet	YES	YES	YES	YES
Vertical flow extension hood (*)	Air flow	Top	YES	YES	YES	YES
Hood with high efficiency air filter (*)	Better filtering	Top	YES	YES	YES	YES
Plenum with silencing cartridges (*)	Noise reduction	Top	YES	YES	YES	YES
Horizontal hood with grid	Air flow	Top	YES	NO	NO	NO
Air economizer (*)	Air flow	Top	NO	YES	YES	YES
Plenum with display	Better access to control panel	Front panel	NO	NO	NO	YES
Leak Detectors	Water leak detection	Bottom	YES	YES	YES	YES
Flange Connection	To create flanged chilled water connection	Chilled water connection	YES	YES	YES	YES

2 - Legs kit

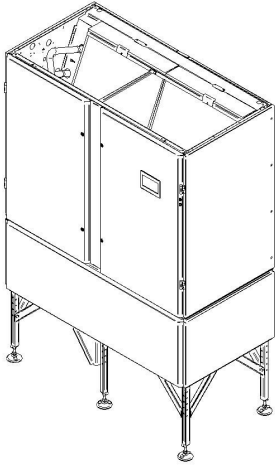

Purpose	To support the unit when installed with a raised floor.
Description	The legs are adjustable and allow to support the unit at different height.
For airflow version	D - Downflow Up E - Downflow Down
Available height	30–370 mm 370–570 mm 570–800 mm
Assembly	Fix the accessory using the threaded inserts that you find in the fan module frame. You need M8 screws (they are not supplied with the unit).

3 - Base frame

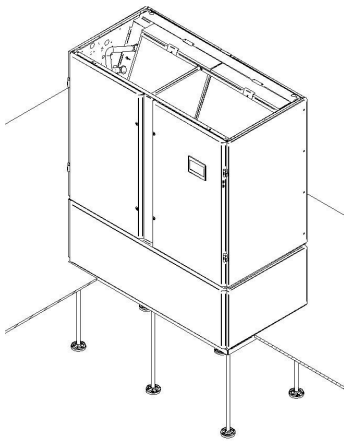

Purpose	To support the unit when installed with a raised floor.
Description	The legs are adjustable and allow to support the unit at different height. A protective grid prevents any contact with the fans from below.
For airflow version	D - Downflow Up E - Downflow Down U - Upflow Frontal
Available height	120–800 mm
Assembly	Fix the accessory using the threaded inserts that you find in the fan module frame. You need M8 screws (they are not supplied with the unit).

4 - Base module

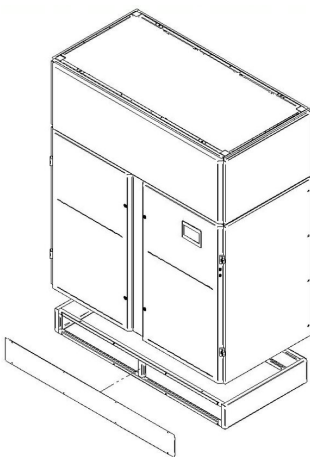

Purpose	To support the unit. Allow the piping to enter the base of the unit when a raised floor is not installed.
For airflow version	U - Upflow H - Frontal
Available height	200 mm
Assembly	Fix to the unit base by 4 screws (the screws are not supplied with the unit)

5 - Base module 600/300 mm high with rear/bottom air intake

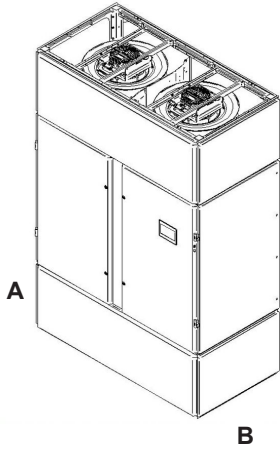

Purpose	To allow an Upflow unit to work with a rear/bottom or a bottom air intake. Supporting the unit. Allow the piping to enter the base of the unit when a raised floor is not installed.
For airflow version	U - Upflow
Available height	[A] rear/bottom air intake H=600 mm [B] bottom air intake H=300 mm
Assembly	Fix to the unit base by 4 screws (the screws are not supplied with the unit)
NOTE	The unit must be ordered with a blind front panel and an open basement

6 - Fresh air module

Upflow

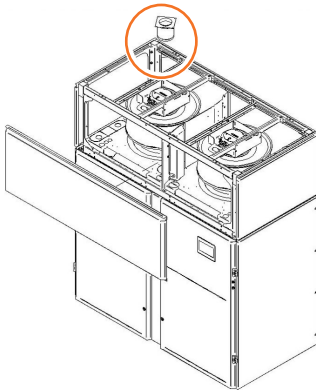

Downflow

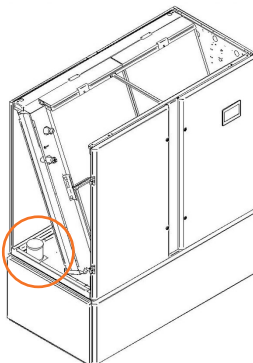

Purpose	To allow filtered fresh air intake from outdoor. The fresh air is mixed with the recirculation air returning from the room.
Description	The kit is made of a G3 class filter with a 100 mm diameter plastic duct.
Available diameter	100 mm
For airflow version	U - Upflow H - Downflow Frontal D - Downflow Up E - Downflow Down
Assembly	The kit must be installed on the low pressure side of the fan. <ul style="list-style-type: none"> Remove the pre-cut in the plate that separates the fan module from the coil module. Insert the kit in the hole, paying attention to push the filter into the low pressure side. Connect the fresh air piping to the kit.

7 - Vertical flow extension hood

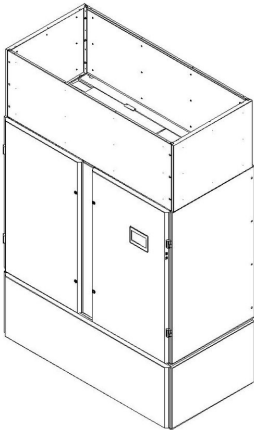

Purpose	Additional duct on the unit top, to simplify the connection to the ceiling or to other equipment.
Description	The hood has the same design as the unit and consists of sandwich panels lined with non-flammable insulation material of class 0 (ISO 1182.2), density 30 kg/m ³ .
For airflow version	U - Upflow H - Downflow Frontal D - Downflow Up E - Downflow Down
Available heights	500 mm 600 mm 700 mm 800 mm 900 mm
Assembly	For all units: fix the accessory to the unit top by screws (the screws are not supplied with the unit).

8 - Hood with high efficiency air filter

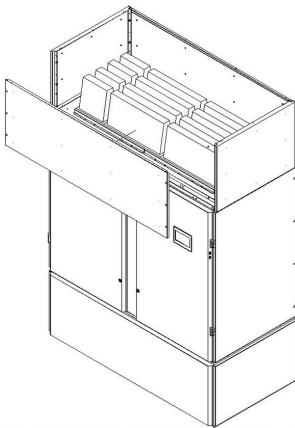

Purpose	Optional high efficiency filters, filtration class ePM10 70% in accordance with the ISO/EN 16890 standard.
Description	The filters are made of fiberglass filter media. They are placed in "V" sections with a solid external frame in polypropylene and can withstand remarkable pressure and flow variations. The filters are installed inside an additional duct on the unit top.
For airflow version	U - Upflow H - Downflow Frontal D - Downflow Up E - Downflow Down
Available height	600 mm 900 mm
Assembly	For all units: fix the accessory to the unit top by screws (the screws are not supplied with the unit).

9 - Plenum with silencing cartridges

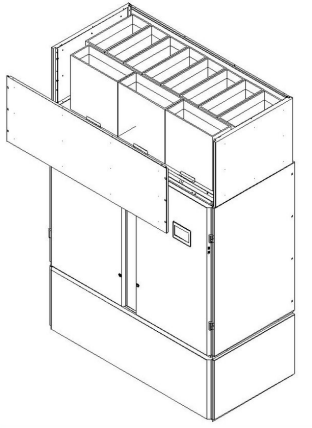

Purpose	Noise reduction
Description	<p>These are special cartridges made of self-extinguishing material with a high noise attenuation capacity.</p> <p>They are guaranteed against disintegration and release of particles due to friction of the air.</p> <p>Despite a small additional pressure drop, these cartridges provide a remarkable sound power level reduction.</p>
For airflow version	<p>U - Upflow</p> <p>H - Downflow Frontal</p> <p>D - Downflow Up</p> <p>E - Downflow Down</p>
Available height	<p>600 mm</p> <p>900 mm</p>
Assembly	For all units: fix the accessory to the unit top by screws (the screws are not supplied with the unit).

10 - Horizontal hood with grid

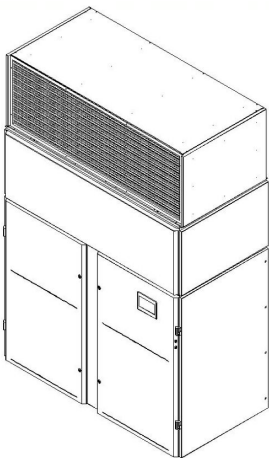

Purpose	<p>Airflow optimization</p> <p>Noise reduction</p>
Description	<p>A supply plenum with horizontal air flow can be installed on top of the unit.</p> <p>The plenum consists of sandwich panels lined with non-flammable insulation material of class 0 (ISO 1182.2), density 30 kg/m³.</p> <p>It is equipped with a double deflection grill.</p>
For airflow version	U - Upflow
Available height	600 mm
Assembly	For all units: fix the accessory to the unit top by screws (the screws are not supplied with the unit).

11 - Air economizer

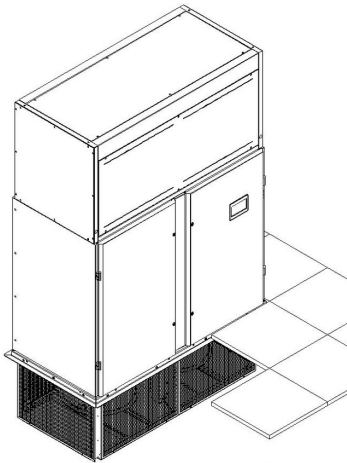

Purpose High energy savings by reducing the chilled water circulation.
The unit takes cool air from outdoors and uses it for room conditioning.

Description The air economizer is an extension hood with two dampers and two temperature sensors.
A sensor measures the temperature of the outdoor (**cold**) air. The other sensor measures the temperature of the **warm air** returning to the unit from the room.
When the outdoor temperature is low enough, the control opens the dampers, one for outdoor air intake, the other for room air intake.
The outdoor air is mixed with the room air to adjust the temperature. The air mixture is filtered by flowing through to unit.
When the outdoor temperature is too high, the control closes the dampers.

For airflow version **H - Downflow Frontal**
D - Downflow Up
E - Downflow Down

Available height 860 mm

Assembly Then fix the accessory to the unit top by screws (the screws are not supplied with the unit).

NOTE *To use the air economizer the building has to be equipped with suitable air ducts for the outdoor air intake.*
The air economizer is supplied with a remote temperature sensor, to be mounted on the outdoor air intake.

Dampers arrangement

The two dampers can be placed in different positions, to fit best the room and air ducts layout. See below all the possible arrangements.

- Outdoor (**cold**) air
- Room (**warm**) air

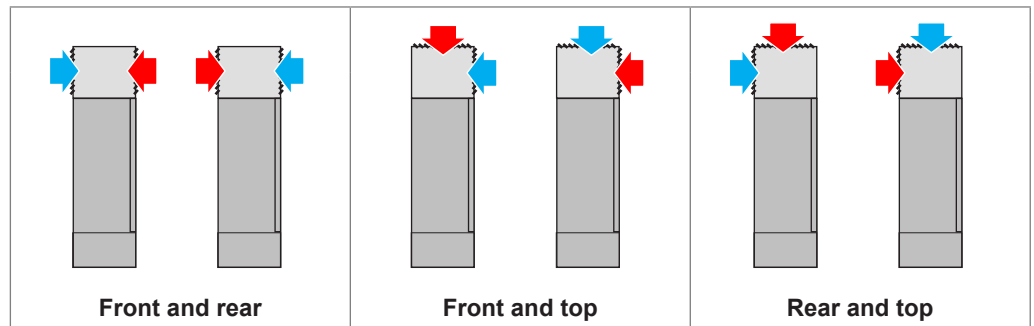

12 - Floor tiles support kit

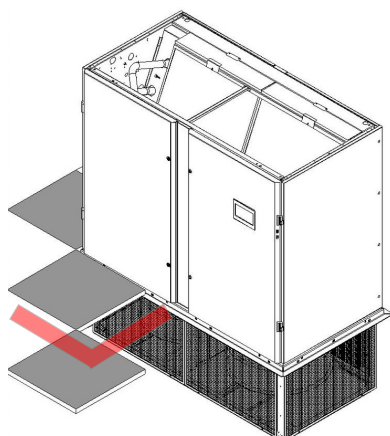

Purpose To support the floor tiles around the **Downflow Down** units when installed with a raised floor.

Description The floor tiles support is fixed on the fan module frame.

For airflow version **E - Downflow Down**

Available dimension For tiles thickness up to 40 mm.

Assembly Fix the accessory using the threaded inserts that you find in the fan module frame. You need M8 screws (they are not supplied with the unit).

NOTE 1 *With a correct installation, the maximum admitted vertical distributed load on the perimeter is 180 kg/m. It means that on the lateral side, which is 870 mm long, the maximum admitted distributed load is 157 kg.*

NOTE 2 *The floor tiles support is earthed with the unit frame. Follow local rules for system grounding*

13 - Fans maintenance kit

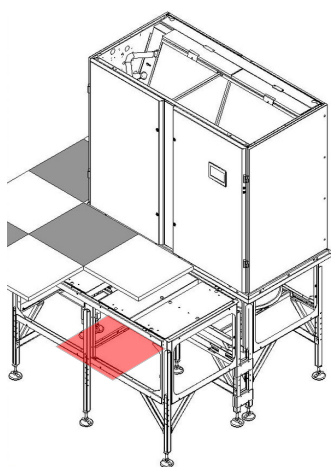

Purpose To allow maintenance operations, in particular fans replacement, when the fans are installed below the floor level

Description Removing tiles on the frontal area, it is possible to lift some footboards, moving them on the lower level, creating a service volume in the raised floor.

For airflow version **E - Downflow Down**

Dimension of the footboards 50x50 mm

Assembly Additional frame to be placed under the raised floor in front of the fan compartment.

NOTE 1 *The footboards are designed to support a maximum vertical distributed load of 600 kg/ m2 and a maximum concentrated load of 150 kg.*

NOTE 2 *The fans maintenance kit must be earthed following the local rules.*

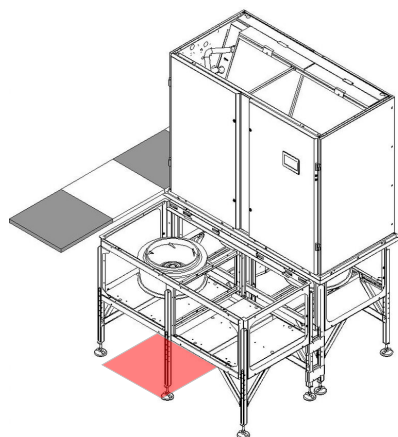

14 - Plenum with display

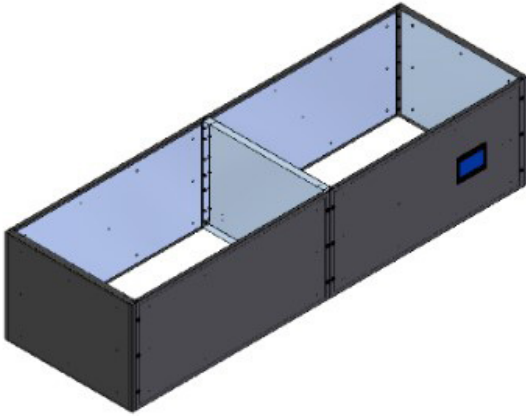

Purpose	Better access to control panel in case of Downflow Down configuration
Description	Downflow Down unit is mounted 600 mm deep in the double floor. That means top of the unit is 600 mm lower than for other types of units and it would be difficult to operate the unit's display. Plenum is used to move PCW's display to optimal/usual height
For airflow version	E - Downflow Down
Available height	600 mm
Assembly	Fix the accessory to the unit top by screws (the screws are not supplied with the unit). And then connect power and signal cable to PCW unit. See details in installation manual attached to accessory.

15 - Leak Detector - Liquistat

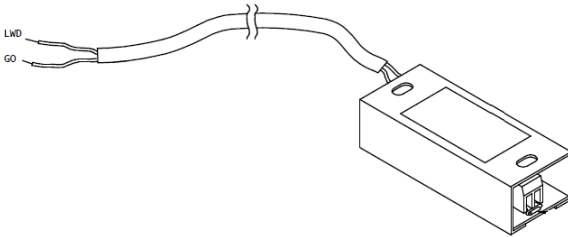

Purpose	The flooding alarm detects the presence of water or of any other conductive liquid and activates an alarm.
Description	Liquistat: It is made up of a corrosion-proof metal container, with access to the two terminals for connecting the line, the detector connection line must be terminated by a 10 kΩ resistor. Up to 5 sensors can be connected to the same flooding alarm device to control many points in the room. Leak detector: The flooding alarm detects the presence of water or of any other conductive liquid and activates an alarm.
For airflow version	E - Downflow Down Downflow Down Back air delivery
Available version	Liquistat

16 - Flange Connection

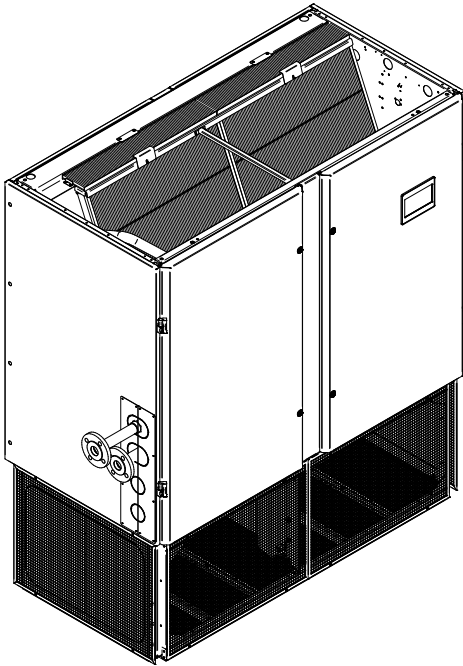

Purpose	To create flanged connection with chilled water system
Description	Flanged stubs ready to be connected to PCW unit's chilled water connection points.
For airflow version	U - Upflow H - Downflow Frontal D - Downflow Up E - Downflow Down
Available version	With threaded connection – Up to connection diameter 42 mm With grooved connection – 54 mm and 64 mm connection diameter For all connection - Top, Lateral and Bottom
Assembly	Fix the accessory to the units chiller water grooved connection or by threaded fitting. See details in manual attached to accessory delivery.

17 - Smoke/Fire detector



Purpose	The smoke and fire detector sense the room air: in case of smoke, unit activates the smoke alarm event without any actions; instead in case of fire, unit activates the fire alarm event and shuts the unit down. Dry contacts are available for a remote customer alarm. This smoke detector is not intended to function as or replace any room smoke detection system that may be required by local or national codes.
----------------	---

18 - Plenum with damper

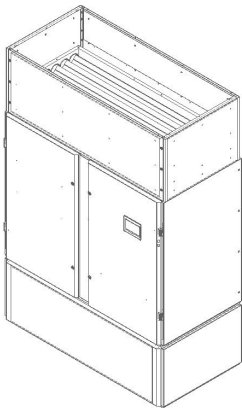

Purpose	An 600 mm. extension hood can be supplied on request and can be installed on top of the unit. Inside the plenum a motorized damper with servomotor (with 3-position or & 0-10V control) is fitted directly controlled by the unit. The unit controls the damper in the safest way managing fans depending on damper position. The plenum shall be the same design as the unit and consist of sandwich panels lined with non-flammable insulation material of class 0 (ISO 1182.2), density 20 kg/m ³
----------------	--

19 - System Display

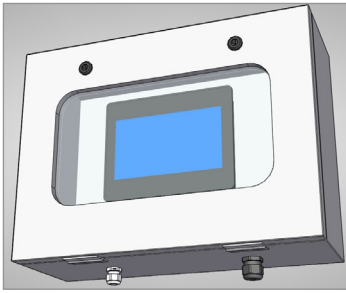

Purpose

The system Display is designed for networking multiple units together. All models have a power supply that requires connection to a single phase 230Vac power source with Schuko socket.

Annex F - Electrode Humidifier

Content

1 - Description.....	167	4 - Startup and operation.....	170
2 - Specifications.....	168	5 - Maintenance.....	170
3 - Installation.....	169	6 - Troubleshooting.....	172

1 - Description

Main Components

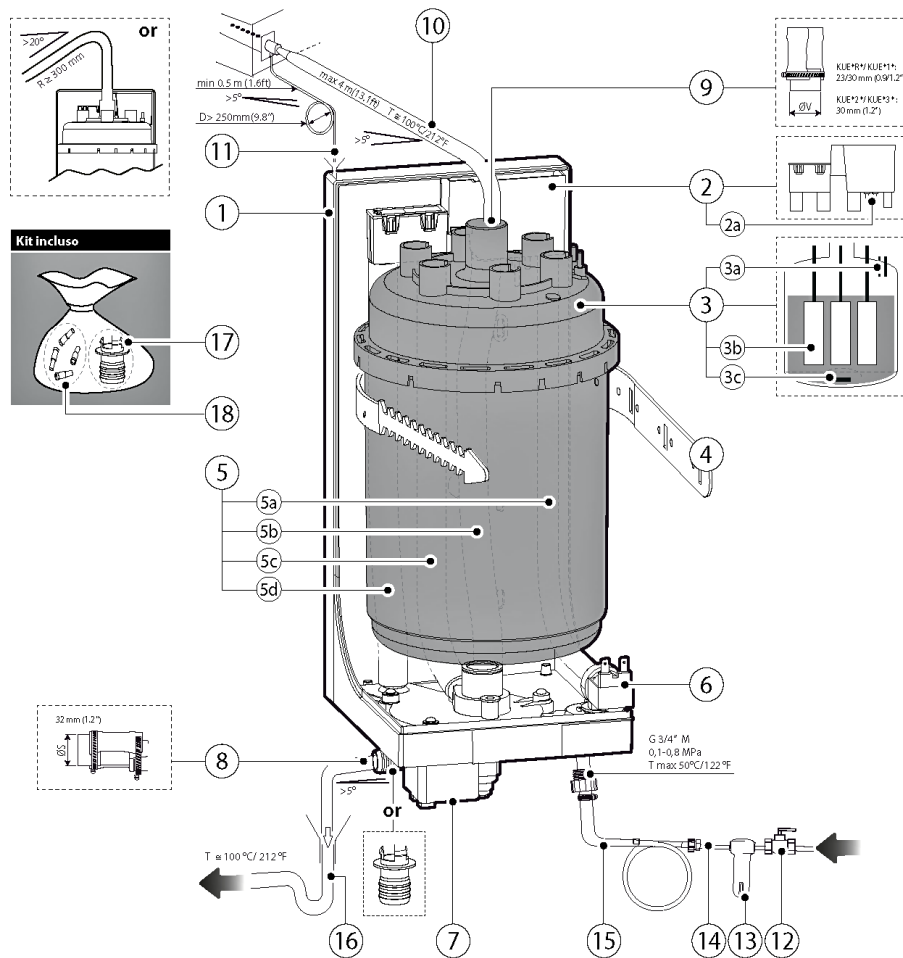

1	Chassis
2	Fill tank
2a	Conductivity electrodes
3	Cylinder
3a	High level electrodes
3b	Immersed electrodes
3c	Filter inside the cylinder
4	Cylinder fastening strap
5	Hose kit
5a	Supply hose
5b	Fill hose
5c	Drain pump and overflow outlet hose
5d	Drain hose
6	Fill solenoid valve
7	Drain pump
8	Drain connection (Ø 32 mm)

Steam distribution

9	Steam outlet
10	Steam distribution hose
11	Steam condensate hose

Water fill

12	Manual valve (not supplied)
13	Mechanical filter
14	Supply hose (not supplied)
15	Connection hose with double non-return valve

Water drain

16	Drain hose with siphon (not supplied)
----	---------------------------------------

Kit included

17	Straight and 90° connection hose (Ø 32 mm)
18	Connectors for electrodes 2a e 3a

Operating principle

The metal electrodes are immersed in the tank filled with common drinking water. When a voltage is applied on the electrodes, an electric current is created in the water, which is slightly conductive since it contains a certain quantity of dissolved mineral salts. The electric current heats the water until producing steam (Joule effect). The quantity of steam produced is proportional to the electric current, which is in turn proportional to the level of water.

2 - Specifications

Technical data

Electrode humidifier technical data

Main power supply	Setting ⁽¹⁾	Absorbed current	Power	MAX water cylinder volume	MAX water supply	MAX drained water
[V ± 10%]	[kg/h]	[A]	[kW]	[l]	[l/min]	[l/min]
400 V / 3 ph / 60 Hz	3,9 - 8	8,7	6	5,5	0,6	7,0
460 V / 3 ph / 60 Hz	3,9 - 8	7,5	6	5,5	0,6	7,0
380 V / 3 ph / 60 Hz	3,9 - 8	9,1	6	5,5	0,6	7,0

(1) The humidifier can be set between the 30 - 100% of the capacity, in steps of 10%. The humidifier mounted in the unit is factory-set to produce about 50% of the maximum value.

Supply water

Only use drinking water with the following specifications:

- pressure between 0,1 and 0,8 MPa (1 and 8 bar)
- temperature between 1 and 40°C
- instant flow rate no higher than the "MAXwater supply" given in the table *Electrode humidifier technical data*
- hardness no greater than 400 ppm of CaCO₃ (40°FH)
- conductivity range: 75-1250 µS/cm



NOTICE

In case of VDI 6022 compliance, the supply water needs to meet additional criteria:

Only use drinking water regarding to the directive (EU) 2020/2184 of European Parliament and of the Council of 16 December 2020 on the quality of water intended for human consumption, especially with the following specification:

- Legionella <100 CFU / 100ml

Supply water chemical specifications

Inorganic compounds	Unit of measure	Normal water		Water with low salt content	
		MIN	MAX	MIN	MAX
Hydrogen ions	(pH)	7	8,5	7	8,5
Specific conductivity at 20°C (σR, 20°C)	(σR, 20°C) S/cm	350	1250	75	350
Total dissolved solids (TDS)	mg/l	(1)	(1)	(1)	(1)
Dry residue at 180°C (TH)	mg/l	(1)	(1)	(1)	(1)
Total hardness	mg/l CaCO ₃	100 ⁽²⁾	400	50 ⁽²⁾	160
Temporary hardness	mg/l CaCO ₃	60 ⁽³⁾	300	30 ⁽³⁾	100
Iron + Manganese	mg/l Fe+Mn	=	0.2	=	0.2
Chlorides	ppm Cl ⁻	=	30	=	20
Silica	mg/l SiO ₂	=	20	=	20
Residual chlorine	mg/l Cl ₂	=	0.2	=	0.2
Calcium sulphate	mg/l CaSO ₄	=	100	=	60
Metallic Impurities	mg/l	0	0	0	0
Solvents, thinners, detergents, lubricants	mg/l	0	0	0	0

(1) = values depend on the specific conductivity; in general: TDS≈0,93*σR, 20°C; R180≈0,65*σR, 20°C

(2) = not less than 200% of the chloride content in mg/l CL⁻

(3) = not less than 300% of the chloride content in mg/l CL⁻

NOTE There is not reliable relationship between hardness and conductivity of the water



CAUTION

Do not add disinfectants or anticorrosive compounds to the water, as these are potential irritants.

The use of well water, industrial water or water from cooling circuits and, in general, any potentially chemically or bacteriologically contaminated water is not recommended.



NOTICE

Do not treat the water with softeners, this may cause the entrainment of foam, affecting the operation of the unit.



NOTICE

In case of VDI 6022 compliance, any backflow into the drinking-water mains shall be excluded by means of appropriate backflow prevention devices.

- This needs to be fulfilled by the installer.

Positive pressure is required upstream of the steam generator and solenoid valve is required to prevent flow back of the water.

Drain water

The drain water contains the same substances dissolved in the supply water, however in larger quantities.

It may reach a temperature of 100°C.

It is not toxic and can be drained into the sewerage system, category 3, EN 1717.

Connect the drain hose to an ordinary drainage network with the following specifications:

- install a siphon that must be able to withstand temperatures up to 100°C
- the network must be able to drain a water flow up to 10 l/min



NOTICE

Pay attention in the manual drainage of the steam cylinder if the drainage network is not able to drain 10 l/min, there is a risk of water overflow on the humidifier.

3 - Installation

The humidifier is supplied already mounted within the **Liebert® PCW** unit.

The only necessary operations are the connections to the supply water and drain water.

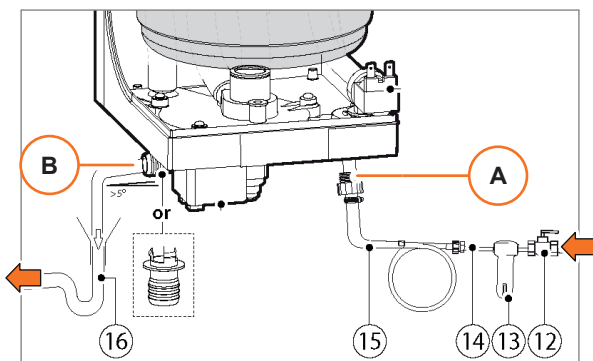

Supply water connection

- Connect to the pipe connection [A] (G 3/4") the following components:
 - [15] connection hose with double non-return valve
 - [14] supply hose (not supplied)
 - [13] mechanical filter
 - [12] manual valve (not supplied)

Drain water connection

- Connect to the drain connection [B] (Ø 32 mm) the drain hose with siphon [16] (not supplied).

Use a drain hose Ø 32 mm, maximum length 10 m with minimum 5% gradient, don't make siphon on this hose to avoid back pressures in the drain piping.

For configuration with bigger length or high head consider the **Liebert® PCW** option with condensate pump.

4 - Startup and operation

Initial checks	<p>Before using the humidifier, check the following conditions:</p> <ul style="list-style-type: none"> - The water supply and drain piping are properly connected. - The shut-OFF valve is open. - All the wirings are properly connected. - The steam hose is properly connected to the steam cylinder and distributor.
Startup	<p>The humidifier is available as soon as the PCW unit is switched on. The humidification request starts the humidifier.</p> <p>When starting with an empty cylinder, the water conductivity is normally insufficient for the humidifier steam output to be reached immediately. Therefore, the humidifier produces as much steam as possible to fill the cylinder completely.</p> <p>If the cylinder is empty at the startup, then the water conductivity could be insufficient to reach immediately the required humidifier steam output. In this case the following actions take place:</p> <ul style="list-style-type: none"> - The water that has evaporated is immediately refilled. - The drain valve is kept shut and therefore, as the steam does not contain any salts, the conductivity of the water within the cylinder slowly increases until the required humidifier steam output is obtained. <p>The length of the startup period depends on the water conductivity.</p> <p>For very conductive water it may occur that the required humidifier steam output is obtained immediately.</p>
Operation	<p>The adjustable parameters which determine the humidifier operation have already been factory-preset (see <i>PDX-PCW Control Application</i>).</p> <p>The steam production rate is controlled by varying the water level in the cylinder.</p> <p>The higher the water level, the deeper the electrodes are immersed into the water and the greater the steam production.</p> <p>Note <i>In case of low water conductivity consult Vertiv™.</i></p>

5 - Maintenance



WARNING

Presence of potentially lethal voltage in some circuits. Presence of water that may leak or pour out. Before doing any operation, always disconnect the power supply.



WARNING

High temperature of some components. High temperature of water. Before doing any operation, wait until all the components and the water have cooled down. Use protective gloves.



NOTICE

Maintenance operations must be carried out only by authorized and trained technicians. We recommend the Vertiv™ Customer Service.

For any operation that is not specifically mentioned in this manual you must contact Vertiv™ Technical Support.

Periodic checks

After extended use, or when using water with a high salt content, the solid deposits that naturally form on the electrodes may reach the stage where they also stick to the inside wall of the cylinder.

If the deposits are very conductive, the heat may melt the plastic, with possible puncture of the cylinder, allowing water to leak back into the tank.

As a precaution, check, at the frequency recommended below, for deposits and the blackening of the wall of the cylinder, and replace the cylinder if necessary.

When	What to check	Disposable cylinders	Openable cylinders
After one hour of operation	<ul style="list-style-type: none"> Any significant water leaks 	YES	YES
Every fifteen days or no more than 300 operating hours	<ul style="list-style-type: none"> Regular operation Any significant water leaks General condition of the casing Arcs or sparks between the electrodes during operation 	YES	YES
Every three months or no more than 1000 operating hours	<ul style="list-style-type: none"> Regular operation Any significant water leaks <ul style="list-style-type: none"> If necessary, replace the cylinder. 	YES	NO
Every three months or no more than 1000 operating hours	<ul style="list-style-type: none"> Marked blackened parts on the casing <ul style="list-style-type: none"> If this is the case, check the condition of the electrodes. If necessary, replace the electrodes together with the O-rings and the cover gasket. 	NO	YES
Annually or no more than 2500 operating hours	<ul style="list-style-type: none"> Regular operation Any significant water leaks General conditions of the container Marked blackened parts on the casing <ul style="list-style-type: none"> If this is the case, check the condition of the electrodes. If necessary, replace the electrodes together with the O-rings and the cover gasket. 	NO	YES

Cylinder replacement

Due to the aging of the plastic and the consumption of the electrodes, even an operable steam cylinder has a limited life and it is, therefore, recommended to replace it according to the following table.

When to replace the cylinder	Disposable cylinders	Openable cylinders
Annually or no more than 2500 operating hours	YES	NO
After five years or no more than 10000 operating hours	YES	YES

Procedure

- Completely drain the water contained in the cylinder.
- Switch **OFF** the **PCW** unit and open the disconnecting switch of the power supply (safety procedure).
- Remove the steam hose from the cylinder.
- Disconnect the electrical connections from the top of the cylinder.
- Release the cylinder from the fastening device and lift it up to remove it.
- Fit the new cylinder in the humidifier by performing the previous operations in reverse order.



NOTICE

Check that the model and the power supply voltage of the new cylinder is the same as the one being replaced.

Replacement and maintenance of other components

Fill solenoid valve	After having disconnected the cables and the piping, remove the solenoid valve and check the condition of the inlet filter. Clean, if necessary, using water and a soft brush.
Supply and drain manifold	Check that there are no solid residues in the cylinder attachment, remove any impurities. Check that the gasket (O-ring) is not damaged or cracked. If necessary, replace it.
Drain pump	Disconnect the power supply. Unscrew the three fastening screws and remove the motor body. Remove any impurity and rinse.
Supply tank and conductivity meter	Check that there are no obstructions or solid particles. Check that the electrodes for measuring the conductivity are clean. Remove any impurity and rinse.
Hose kit	Check that the hoses are free and do not contain impurities. Remove any impurity and rinse.

6 - Troubleshooting

Problem	Cause	Solution
The humidifier does not turn ON	NO electrical power supply	Check the protection device upstream of the humidifier and that the power supply is present
	Controller connectors plugged in incorrectly	Make sure the connectors are properly connected
	Fuses blown Transformer fault	Check the fuses
The humidifier does not start operation	Remote ON/OFF contact open or control signal not compatible with the type set	Make sure the controller is working correctly
	Manual supply valve closed, fill solenoid valve fault or inlet filter dirty	Open the manual valve, check or clean the inlet filter to the fill solenoid valve, replace the fill solenoid valve
	The steam hose is blocked or not installed correctly, that is, blocked by condensate or choked (pocket that fills with condensate)	Check the positioning of the steam hose with reference to the assembly instructions
The humidifier fills with water without producing steam	Excessive back-pressure in steam outlet	Check that the steam outlet hose is not bent or choked
	Cylinder inlet filter blocked	Clean the filter
	Lime scale in the supply tank	Clean the fill/supply tank
	Drain solenoid valve/pump fault	Check for presence of voltage 24 VAC/230 VAC at the drain solenoid valve/pump and/or replace the drain solenoid valve/pump
The line circuit breaker is activated	The circuit breaker is under-rated	Check that the circuit breaker is rated for a current equal at least 1,5 times the rated current of the humidifier
	Excess current at the electrodes	Check the operation of the drain solenoid valve/pump, the seal of the fill solenoid valve when not energized, drain some of the water and restart

Problem	Cause	Solution
The humidifier wets the duct	The steam distributor is not installed correctly (too near the top of the duct or the condensate return is blocked)	Make sure the steam distributor has been installed correctly
	The system is oversized	Decrease the steam production, CP/CPY board
	Humidifier on when the fan in the duct is off	Check the connection of the device (flow switch or differential pressure switch) slaving the operation of the humidifier to the fan in the duct Check the remote on/off input
The humidifier wets the floor below	The supply or overflow circuit has leaks	Check the entire water circuit
	The steam outlet hose is not properly secured to the cylinder	Check that the clamp on the steam outlet is tight

Annex G - Infrared Humidifier

Content

1 - Description.....	175	4 - Startup and operation.....	176
2 - Specifications.....	175	5 - Maintenance.....	176
3 - Installation.....	176	6 - Troubleshooting.....	178

1 - Description

Main components

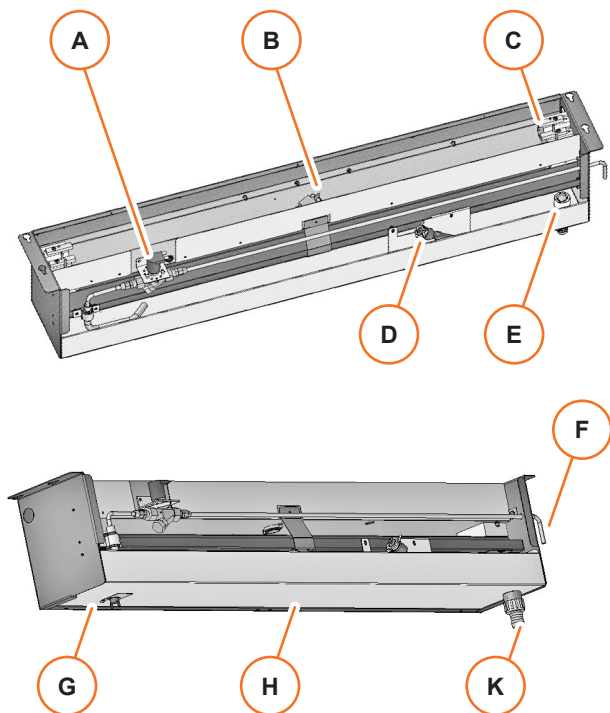

- A Solenoid valve flow regulation

- B Infrared quartz lamps

- C Junction block

- D Float switch

- E Standpipe

- F Water supply

- G Manual reset for the thermostat

- H Pan

- K Discharge connection

Operating principle

The quartz lamps [B] are mounted above the stainless steel pan [H], which is filled with water through the supply inlet [F]. The float switch [D] detects if the water level is too high. When humidification is required, the lamps are switched **ON** and infrared rays generate steam within seconds (without impurities or odor). The lamps never come in contact with the water.

2 - Specifications

Technical data

Infrared humidifier technical data

Size	Main power Supply	Pan	Capacity	Absorbed Current	Power
	[V ± 10%]	Material	[kg/h]	[A]	[kW]
Small	400 V / 3 ph / 50 Hz	Stainless steel	5,0	6,9	4,8
	380 V / 3 ph / 60 Hz	Stainless steel	5,0	7,3	4,8
	460 V / 3 ph / 60 Hz	Stainless steel	5,0	6,0	4,8
Big	400 V / 3 ph / 50 Hz	Stainless steel	10,0	13,9	9,6
	380 V / 3 ph / 60 Hz	Stainless steel	10,0	14,6	9,6
	460 V / 3 ph / 60 Hz	Stainless steel	10,0	12,0	9,6

Supply water

- Pressure between 138 kPa and 1000 kPa
- Flow rate 3,8 l/min



CAUTION

Do not add disinfectants or anticorrosive compounds to the water, as these are potential irritants. The use of well water, industrial water or water from cooling circuits and, in general, any potentially chemically or bacteriologically contaminated water is not recommended.

Drain water

The drain water contains the same substances dissolved in the supply water, however in larger quantities. It may reach a temperature of 100°C.

It is not toxic and can be drained into the sewerage system, category 3, EN 1717.

Connect the drain hose to an ordinary drainage network with the following specifications:

- install a siphon that must be able to withstand temperatures up to 100°C

3 - Installation

The humidifier is supplied already mounted within the **PCW** unit.

The only necessary operations are the connections to the supply water and drain water.

- Supply water connection: external diameter 6 mm
- Drain water connection: internal diameter 22 mm, male tread

4 - Startup and operation

Initial checks

Before using the humidifier, check the following conditions:

- The water supply and drain piping are properly connected.
- The shut-off valve is open.
- All the wirings are properly connected.
- The steam hose is properly connected to the steam cylinder and distributor.

Startup

The humidifier starts up automatically as soon as the **PCW** unit is switched on.

Operation

The adjustable parameters which determine the humidifier operation have already been factory-preset.

5 - Maintenance



WARNING

Presence of potentially lethal voltage in some circuits. Presence of water that may leak or pour out. Before doing any operation, always disconnect the power supply.



WARNING

High temperature of some components. High temperature of water. Before doing any operation, wait until all the components and the water have cooled down. Use protective gloves.



WARNING

Optical radiation from the quartz lamps. Before opening the door, always switch off the **PCW** unit.



NOTICE

Maintenance operations must be carried out only by authorized and trained technicians. We recommend the Vertiv® Customer Service.

For any operation that is not specifically mentioned in this manual you must contact Vertiv® Technical Support.

Periodic checks

- Check drain piping and trap for clogs.
- Check the pan. Clean it from mineral deposits.
- Clean the reflector.
- Check the water supply valve for leaks.
- Check the quartz lamps (replace if burnt out).
- Check the wirings connections (inside the humidifier electric panel).

NOTE Deposits of mineral solids will collect in the humidifier pan and on the float switch. These must be cleaned periodically to ensure proper operation. The frequency of cleaning must be locally established because it depends on humidifier usage and local water quality. A spare pan is recommended to reduce the maintenance time. The Liebert® autoflush system can greatly increase the time between cleaning, but does not eliminate the need for periodic checks and maintenance.

Removing the pan

Before switching off **PCW** unit

- With the **PCW** unit operating, remove the call for humidification at the control.
- Let the fans operate **5** minutes to allow the humidifier and water to cool.
- Let the pan drain and the condensate pump operate (if applicable) until the pan is dry.
- If applicable, let the condensate pump operate until the drain tank is dry.
- Switch off the **PCW** unit.

With the **PCW** unit disconnected from the power supply

- Remove safety panels, if installed.
- Pull out the humidifier standpipe from the pan.
- Inspect the O-ring (replace if necessary).
- Disconnect the drain coupling from the bottom of the pan.
- Remove the thermostat from the bottom of the pan.
- Remove the fixing screws from the sides of the pan and slide the pan out.

Cleaning the pan and the float switch

With the **PCW** unit disconnected from the power supply

- Loosen the scale on the side and bottom of the pan with a stiff nylon brush or plastic scraper.
- Flush with water.
- Carefully clean the scale from the float switch. Make sure to reassemble it correctly:

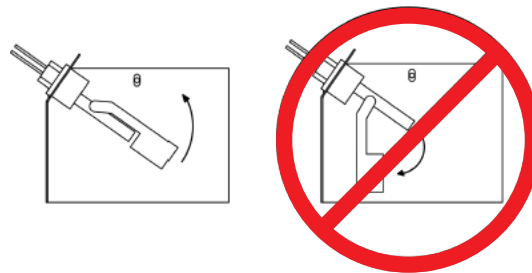

- Reassemble pan, thermostat, standpipe, drain coupling, cover and screws into the humidifier.

With the **PCW** unit connected again to the power supply

- Operate the humidifier and check for leaks.

Changing the lamps



NOTICE

Touching quartz lamps with bare hands will severely shorten their life. Skin oils create hot spots on lamp surface. Wear clean cotton gloves when handling lamps

With the PCW unit disconnected from the power

- Remove the humidifier pan as explained in *Removing the pan*.
- Remove the screws and cover from the high-voltage compartment of the humidifier.
- Disconnect one end of the purple jumper wires.
- Using a continuity meter, locate the burned-out lamp.
- Remove the lamp brackets under the lamps.
- Loosen the two screws securing the lamp lead wires to the junction block.
- Pull the quartz lamp straight down and discard it.
- Wrap the lead wires once around the new lamp's metal ends. This will support the lamp and allow for thermal expansion.
- Insert the lead wires into the junction block and tighten the screws
- Reassemble by performing the previous operations in reverse order.

6 - Troubleshooting

Symptom	Possible cause	Check or remedy
No humidification	Humidifier pan not filling	• Check water supply
		• Check fill valve operation
		• Check drain stand pipe adjustment
		• Check for clogged water supply piping
	Control not calling for humidity	• Check status on control
	Control calling but humidifier not starting	<ul style="list-style-type: none"> • Check visually • If contact is made, check line voltage after contactor, fuses and circuit breakers. • Check for open humidifier safety stat
Quartz lamp burned out	• Replace the quartz lamp	
Loosen lead on old quartz lamp	• Trim excess lead length on new quartz lamp to avoid shorts	

Annex H - Ultrasonic Humidifier

Content

1 - Description.....	179	4 - Startup and operation.....	182
2 - Specifications.....	180	5 - Maintenance.....	182
3 - Installation.....	181		

1 - Description

NOTE This type of humidifier is available only for units with Downflow Up air distribution.

Main components

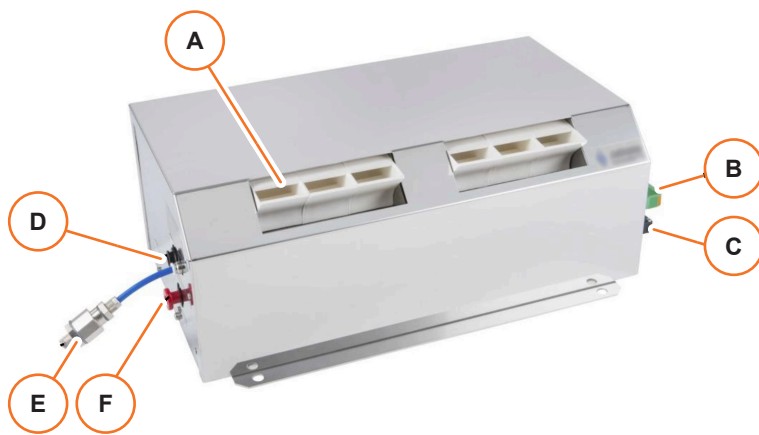

A	Mist outlet
B	Input and output for control signals
C	Input for power supply
D	Water overflow push-in connection Ø 12 mm
E	Demineralized water inlet screwed connection for Ø 6/4 mm
F	Water drainage push-in connection Ø 12 mm

Operating principle

Piezoceramic transducers are attached to the bottom of a tank filled with water.

The transducers produce ultrasonic vibrations that create capillary waves on the water surface, developing a water mist.

The air flow produced by a fan diffuses the aerosol in the ambient air.

The humidifier consists of nebulization modules, valve for the control of the supply water, float switch and a case that houses the fan.

The humidifier is provided with the following protective functions:

Dry-running	If the water level falls below minimum, humidification switches OFF automatically.
Overheating	Humidification switches off at water temperatures > 60°C.
Overflow	If the water tank is overfilled, the excess water is drained off to the outside.

2 - Specifications

Technical data

Ultrasonic humidifier technical data

Model	Main power Supply ⁽¹⁾	Capacity ⁽²⁾	Transformer	Power Consumption	Absorbed Current	Number of Transducers
	[V ± 10%]	[kg/h]	[VA]	[W]	[A]	-
RB/P-D16-WKT	400 V / 1 ph / 50 Hz 380-400 V / 1 ph / 60 Hz 460 V / 1 ph / 60 Hz	0 - 8,0	800	650	13,5	16

(1) The unit is equipped with an internal transformer to provide the 48 V_{AC} at the humidifier.

(2) The humidification capacity is modulated by the control based on the request.

NOTE The ultrasonic humidifier has its own internal microprocessor, the main unit provides a 0 – 10 V_{DC} signal to regulate the capacity.

Operating conditions

Air	Maximum air humidity	< 90 % relative humidity – no condensation
	Air temperature	5 - 45°C
Supply water	Pure water pressure	1 - 4 bar
	Pure water quality	fully demineralized
	Pure water conductivity	5 - 20 µS/cm

NOTE If demineralized water is not available, provide a demineralizer (not supplied). Dust or dirt must not get into the water lines.



CAUTION

Do not add disinfectants or anticorrosive compounds to the water, as these are potential irritants.



NOTICE

The demineralized water is corrosive, therefore use stainless steel or plastic only. Non-ferrous metals (e.g. copper, brass) must not be used.

Drain water

The drain water contains the same substances dissolved in the supply water, however in larger quantities.

It is not toxic and can be drained into the sewerage system, category 3, EN 1717.

Connect the drain hose to an ordinary drainage network with the following specifications:

- install a siphon

3 - Installation

Assembly with the PCW unit

The humidifier is supplied mounted within a base module 400 mm high.

The base module with humidifier is supplied stand alone and it must be installed and connected with the **PCW** unit on field, in one of the following configurations:

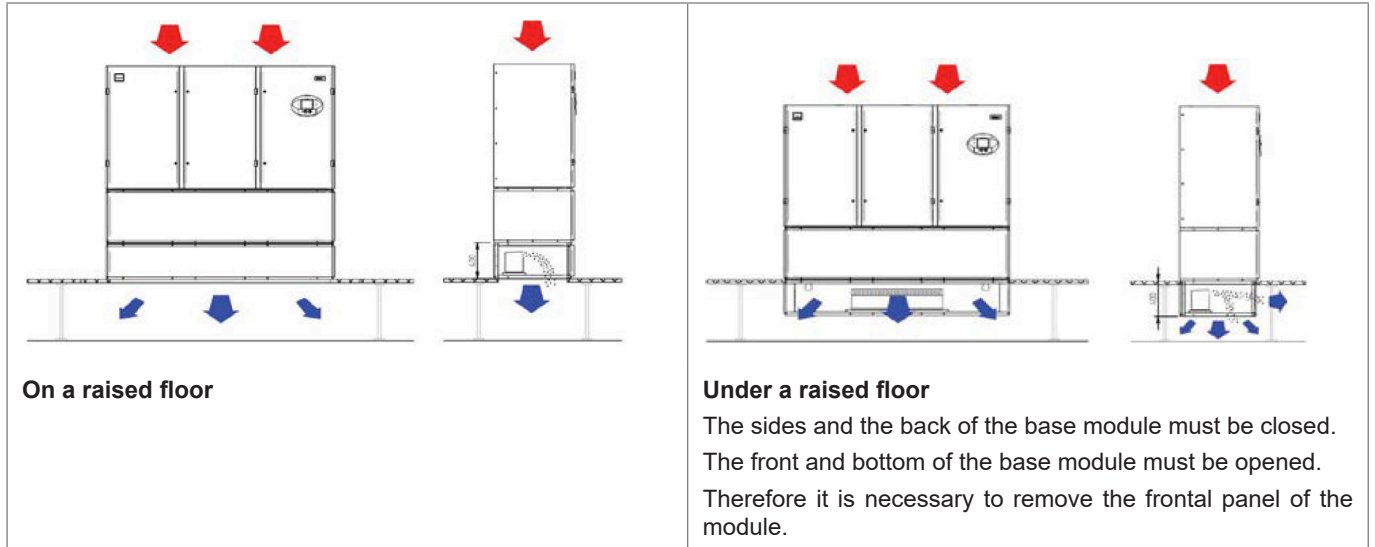

On a raised floor

Under a raised floor

The sides and the back of the base module must be closed. The front and bottom of the base module must be opened. Therefore it is necessary to remove the frontal panel of the module.

A base frame, available on request, is required to support the base module (see *Annex F - Accessories*).

- Ensure 1 m of free space (without obstacles) on ultrasonic humidifier module outlet.
- For Extended Height unit, connect the fan module above the humidifier module and then the coil module above the fan module.

Connections

- Connect humidifier electrical cable, coming from the air conditioner, to the ultrasonic humidifier.
- Connect demineralization water supply, water drain, safety overflow and humidifier drain as shown in the following figure.

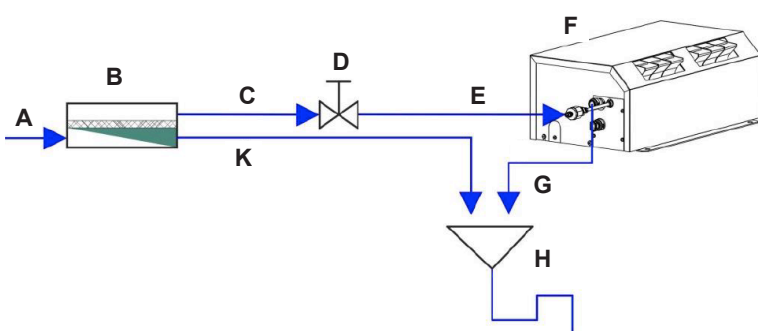

- A Drinking water supply (on site)
- B Demineralization system (not included with the humidifier)
- C Demineralized water inlet
- D Shut-OFF valve (delivered with the humidifier)
- E Plastic tube Ø 6/4 mm for demineralized water supply
- F Humidifier
- G Water overflow and discharge for plastic tube Ø 12 mm
- H Drainage (on site)
- K Concentrate



NOTICE

Demineralized water pipes must be flushed prior to commissioning the humidifier.

4 - Startup and operation

Initial checks	<p>Before using the humidifier, check the following conditions:</p> <ul style="list-style-type: none"> - The water supply and drain piping are properly connected. - The shut-OFF valve is open. - All the wirings are properly connected. - The steam hose is properly connected to the steam cylinder and distributor.
Startup	The humidifier starts up automatically as soon as the PCW unit is switched ON .
Operation	The adjustable parameters which determine the humidifier operation have already been factory-preset (see <i>PDX-PCW Control Application</i>).

5 - Maintenance



WARNING

Presence of potentially lethal voltage in some circuits. Presence of water that may leak or pour out. Before doing any operation, always disconnect the power supply.



WARNING

High temperature of some components. High temperature of water. Before doing any operation, wait until all the components and the water have cooled down. Use protective gloves.



NOTICE

Maintenance operations must be carried out only by authorized and trained technicians. We recommend the Vertiv™ Customer Service. For any operation that is not specifically mentioned in this manual you must contact Vertiv™ Technical Support.



NOTICE

Never use high pressure cleaners to clean the humidifier. Use grease and oil-free materials only. Never operate the humidifier without air supply.



NOTICE

If the humidifier is not used for a long period, the water must be drained **OFF**.

Periodical checks

- Check drain piping and trap for clogs.
- Check the wirings connections (inside the humidifier electric panel).
- Check the condition of the air intake filters. Clean them, if necessary.

Cleaning

Water tank	Use a clean, totally fat-free medium hard brush and clean water.
Transducers	<p>Wipe with a soft, scratch-free cloth.</p> <p>Scaling or solid deposits on the transducers must be carefully removed. For that purpose, it is recommended to use 20 % formic acid.</p> <p>NOTE <i>Deposits are a direct consequence of inadequate water quality.</i></p>

Annex I - ATS (Automatic Transfer Switch) - optional

Content

1 - Safety instructions.....	183	5 - Operation.....	188
2 - Description.....	184	6 - Maintenance.....	190
3 - Specifications.....	185	7 - Troubleshooting.....	191
4 - Installation.....	187		

1 - Safety instructions



WARNING

Improper operations can cause injury or death.



NOTICE

Improper operations can cause product damage.



Read carefully the chapter *1. Safety*.

Pay attention to the safety labels on the unit and to the safety warnings in this chapter.

Covers

- The only cover that can be opened is the one for the auto/manual switching.
- Do not open any other cover (with or without voltage) as there may still be dangerous voltage inside the unit from external circuits.

Cables

- Do not handle any control or power cables connected to the ATS when voltage may be present on the unit (directly through the mains or indirectly through external circuits).
- Always use an appropriate voltage detection device to confirm the absence of voltage.

Personnel

- Maintenance and servicing operations must be performed only by trained and authorized personnel.

Arc hazard

- Ensure that no metal objects can fall in the cabinet (risk of electrical arcing).

2 - Description

Components for manual operation and locking

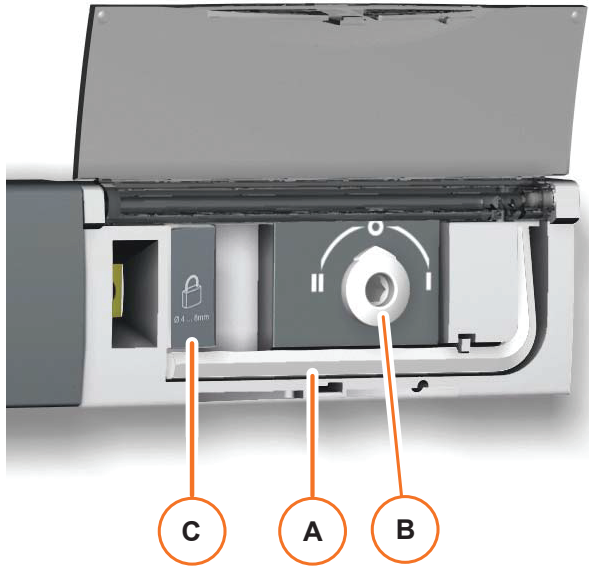

- A The hex/Allen key for manual operation
- B Changeover switch for manual operation
- C Safety locking clip for locking disconnected position - O

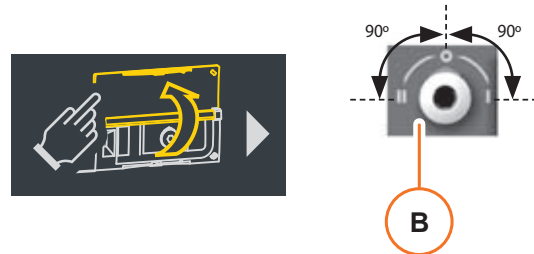

NOTE: Open the front cover as shown to put into manual mode.

Operating principle

ATS is an “Automatic Transfer Switching” equipment and it is designed for use in power system for the safe transfer of a load supply between a normal (priority) power supply and a secondary (alternate) power supply. The changeover is done in open transition and with minimum supply interruption.

The ATS models used in the **PCW** units are with 4 poles.

The transfer switch ensures:

- Power control and safety between a normal and an alternate source.
- Intuitive HMI for emergency and local operation.
- Integrated and robust switch connection.
- Clearly visible position indication I – O – II.
- An inherent failsafe mechanical interlock.
- Stable positions (I – O – II) non-affected by typical vibrations and shocks.
- Fixed pressure on the contacts non-affected by network voltage.
- Energy efficiency with virtually no consumption whilst on the normal, alternate or off positions.

Three types of ATS are available:

- Type 03: configurable through four potentiometers and DIP switches

ATS feedback (optional):

Monitoring Relay to provide customer information for use of Main or Backup line.

3 - Specifications

ATS type 03

Power section	Fully integrated and interlocked transfer switch, with high electrical performance offering microprocessor control and monitoring.
Operation	Flexible operating mechanism enabling quick motorized transfer in automatic mode or locally in manual mode for emergency operations. A locking device ensures (in position “O”) a secured isolation of the load.
Measurement	Accuracy: frequency $\pm 1\%$ and voltage $\pm 1\%$.

Electrical connection

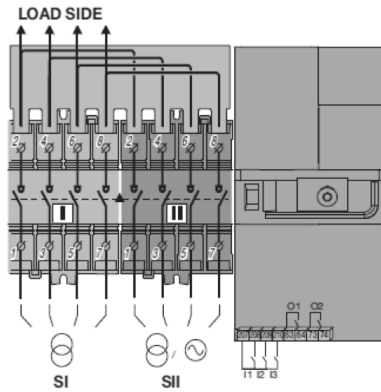

A bridge bars provides a common point on the outgoing side of the switch (load side) and it is direct linked to the unit disconnecting switch. This cabling arrived from the factory.

LEDs indications

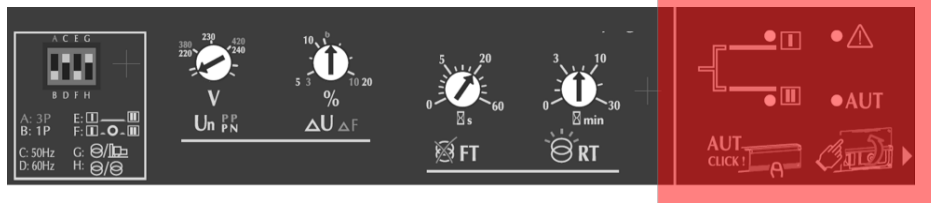

The LEDs indicates the source availability, the fault and the state of the product as specified in the following table:

Source / State	LED ON	LED OFF	LED blinking
I	Source 1: Available	Source 1: missing or out of range	A timer is counting down or test mode
II	Source 2: Available	Source 2: missing or out of range	A timer is counting down or test mode
	Fault	Product OK	Wait
AUT	Auto Mode	Manual Mode	Manual retransfer

NOTE To reset a fault, it is required to open the cover.

Technical data

Ratings		63 A
Type		Type 03
Frequencies		50 – 60 Hz
Thermal current I_{th} at 40°C [A]		63
Short-circuit capacity	Rated short-term withstand current: I_{CW} 1s [KA_{eff}]	4
	Rated short-term withstand current: I_{CW} 30ms [KA_{eff}]	10
Switching time at I_n excluding loss of supply sensing time and excluding any delay timers applicable	I – II or II – [ms]	180
	Duration of “Electrical Blackout” at U_n [ms]	90
	I – O, O – I, II – O, O – II [ms]	45
Connection cross-section	Minimum size [Cu mm ²] flexible and rigid	10
	Maximum size [Cu mm ²] flexible and rigid	70

NOTE Maximum altitude without de-rating: 2000 meters. Maximum air temperature without de-rating: 40°C.

Unit models	ATS Type	Rating
All models	Type 03	63 A

4 - Installation

The **PCW** unit is delivered with the ATS already installed.

The only operation to be done on site is to connect the priority supply line and the secondary supply line to the ATS.

The ATS is placed inside a separate electrical panel and fixed on a DIN rail.

Two cable glands are present on the bottom part of the electric panel to allow the cable passage with the required IP rates.

Cables connections

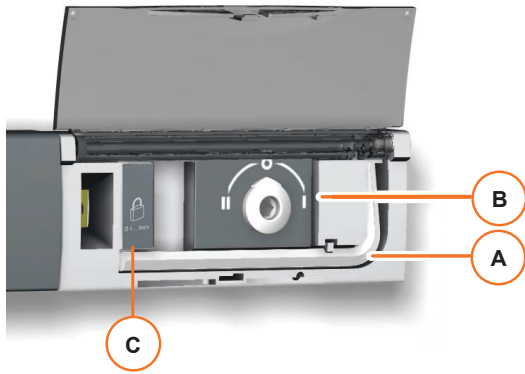

- Disconnect the power supply to the **PCW** unit through the general disconnecting switch.
- Insert the Hex/Allen key **[A]** in the ATS disconnecting switch and turn the handle to position “**O**”.
- Insert a padlock in the handle as explained in *Locking the switch in the disconnecting position* to prevent uncontrolled restore of the electrical power.
- Connect the priority line on the terminals **I**.
- Connect the secondary line on the terminal **II**.

Configuration for type 03

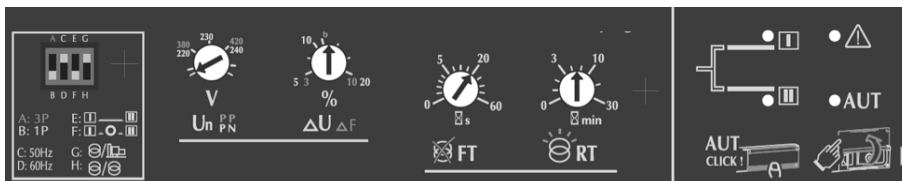

- Open the Auto / Manual cover to set the DIP switches.

The ATS type 03 arrives pre-configured from the factory as described in the following table:

	Available configuration	Factory configuration
DIP switch 1	A: three phases B: single phase	A
DIP switch 2	C: 50 Hz D: 60 Hz	According to unit power supply
DIP switch 3	E: no stop in 0 position F: 2 seconds of stop in 0 position	E
DIP switch 4	G: Network – Genset H: Network – Network	H
Potentiometer 1	Adjustment potentiometers of the rated voltage threshold	230 – 400 V
Potentiometer 2	Adjustment potentiometers of the rated frequency threshold (as % of frequency and voltage)	10%
Potentiometer 3	Fault time, no commutation if the missing voltage time is less than the setting	0 sec
Potentiometer 4	Return time, minimum required time to return on the main/priority line	0 sec

NOTE For different voltage and frequency, please contact the Vertiv™ Technical Support.

5 - Operation

Manual mode

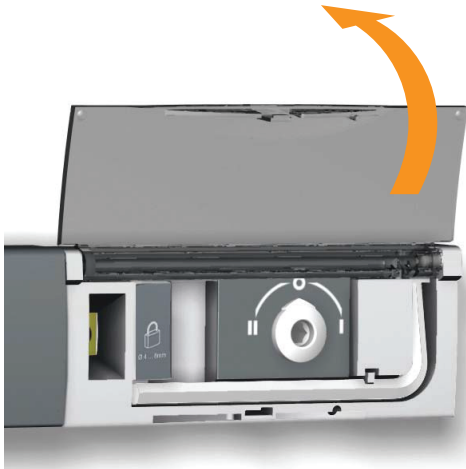

- Open the cover to switch to manual mode
- Insert the Hex/Allen key to set the ATS to the manual mode.

Now the automatic operations are disabled and the switch will not operate automatically in case of power failure.

You may turn the switch to each of the following positions:

- I - priority power supply
- O - power supply disconnected
- II - secondary (alternate) power supply

Automatic mode



- Close the cover to switch to automatic mode

Now the power supply is normal.

During the initial power-up the ATS will be in automatic mode and it will switch to the primary line.

NOTE Keep the cover open if you do not want the ATS to be in automatic mode during the initial power-up.



NOTICE

Before powering on the ATS, manually operate it to ensure that it can move normally.

Locking the switch in the disconnecting position

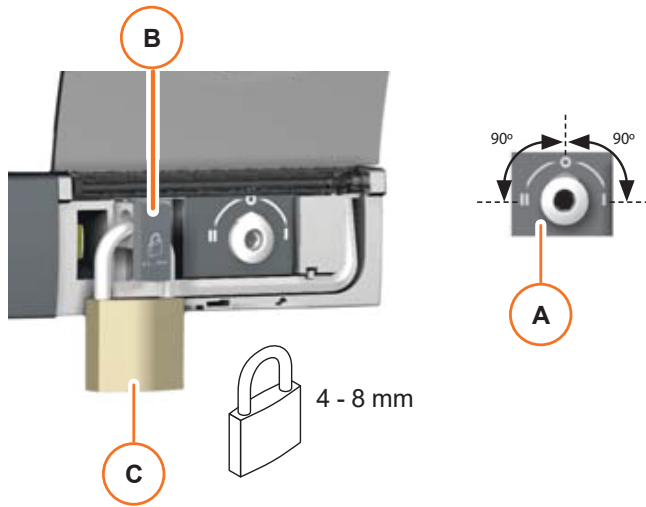

- Insert the handle to the switch [A] and turn it to position “O”.
- Lift the locking clip [B].
- Insert your padlock [C] in the clip (4-8 diameter).

Now the switch is locked in the power disconnecting position.

NOTE *The handle can be padlocked only in the “O” position.*

6 - Maintenance

Periodic checks and operations

- Check if the electrical connections are tight.
- Tighten any loosen connection.

Replacement



Unscrew to allow movement on the DIN rail.

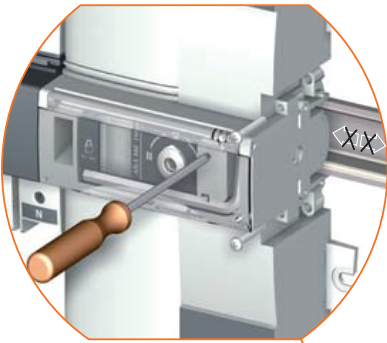

Posidriv PZ1
1 Nm

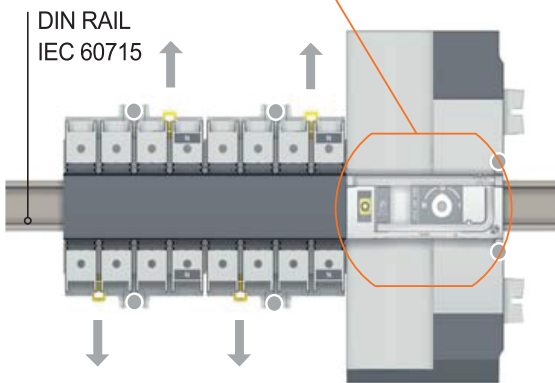

NOTE: Screws indicated by grey dot ●
Eyes [A], [B] indicated by grey arrow ↓

The ATS fault is indicated by the LEDs as following:

- ATS type 03: the “Fault” LED IS **ON**

NOTE For ATS type 03, you may try to reset the error by opening and the closing the cover. If the fault persists, follow the procedure below to replace it.

How to remove the ATS

- Disconnect the power supply to the **PCW** unit through the general disconnecting switch.
- Switch in manual mode and set the position of the handle on “O”.
- Secure disconnected position with the padlock (follow previous chapter 5 Operation - Locking the switch in the disconnecting position)
- Disconnect all the electrical cables:
 - line I
 - line II
 - outgoing line (load side)
 - control cables
- Remove all the screws that fix the ATS on the DIN rail (2 x screws on the left from position switch - PZ1 screwdriver needed) and on the electrical panel (6 x screw - Hex nut driver 10 mm needed).
- Insert a screw driver in one of the eyes placed on the upper part of the ATS and pull it out from the DIN rail (repeat for the other eye(s)).
- Insert a screw driver in one of the eyes placed below the ATS and pull it out from the DIN rail (repeat for the other eye(s)). When all the connection points are free, lift the ATS and remove it.

How to remove the ATS

- Switch the new ATS in manual mode and set the position of its handle on “O”.
- Secure disconnected position with the padlock (follow previous chapter 5 Operation - Locking the switch in the disconnecting position)
- Place the ATS on the DIN rail and press until it locks.
- Fix all the screws that fix the ATS at the DIN rail and at the electrical panel.
- Connect all the electrical cables:
 - line I
 - line II
 - outgoing line (load side)
 - control cables
- For the ATS type 03: adjust the configuration settings.
- Connect the **PCW** unit to the power supply.
- Restart the **PCW** unit.

7 - Troubleshooting

ATS type 03

Symptom	Possible Cause	Check or remedy
The "Priority SOURCE availability" LED does not come ON	DIP switches not set correctly	Set the DIP switch according to electrical diagram
	Wrong nominal voltage	Measure the voltage across the terminals and report the value on the potentiometer
The "Emergency SOURCE availability" LED does not come ON	DIP switches not set correctly	Set the DIP switch according to electrical diagram
	Wrong nominal voltage	Measure the voltage across the terminals and report the value on the potentiometer
The product remains switched off after the "Priority SOURCE" is lost	The voltage across the power supply terminal of the emergency mode is not between 176 to 288 V _{ac}	Check it through a potentiometer
	In case of transformer/Genset, check that FT timer (Main Failure Timer) has finished counting down.	Check the setting of the failure timer.
The product remains switched off after the "Priority SOURCE" is lost	The product is in manual mode.	Make sure the switch is working in "AUTO" mode.
	The automatic operation is inhibited by an external control command.	Check the configuration of the remote control.
	The LED "AUT" and "Emergency SOURCE availability" are lit.	Check the power line status.
The product remains switched off after the "Priority SOURCE" is restored	The product is in manual mode.	Make sure that the switch is working in "AUTO" mode.
	The automatic operation is inhibited by an external control command.	Check the configuration of the remote control.
	The LED "Primary SOURCE Availability" is lit.	Check the power line status.
	The Main Return Timer (RT) could be set between 0 – 30 minutes	Check that RT is set correctly.
	"Manual retransfer" is activate.	Check the "Manual Retransfer" function.
Return to "Priority SOURCE" has been execute, but the "Emergency SOURCE" (for a generator) continues to operate	The product is in manual mode.	Make sure the switch is working in "AUTO" mode.
	CDT (cool down timer) has not finished counting down – Fixed time delay 4 minutes.	Check the stopwatch.
	The automatic operation is inhibited by an external control command.	Check the configuration of the remote control.
The product cannot be switched over using the handle	Wrong rotation handle	Check the rotation handle
	The product is Padlocked	Check that the product is not padlocked
Automatic mode is not activated even when the cover is closed	The "AUT" LED is not lit	Check that the plastic pin is in place at the bottom of the cover. This pin activates the sensor which indicates the position of the cover (open or closed).

Annex J - Additional Options

Content

1 - Overpressure damper.....	193	8 - Ethernet Switch.....	193
2 - Motorized damper.....	193	9 - Phase Detector.....	193
3 - Spring return damper.....	193	10 - Smart Aisle™.....	194
4 - Bottom Air Intake.....	193	11 - Cooling Overdrive.....	194
5 - Allarm card.....	193	12 - Super Saver.....	194
6 - Pressure control.....	193	13 - Energy meter.....	194
7 - Ethernet Switch.....	193		

1 - Overpressure damper

Overpressure damper fitted on the top of the unit, which closes in case of no airflow exploiting gravity effect.

2 - Motorized damper

Motorized Damper with servomotor fitted on the top directly controlled by the unit. The unit controls the damper in the safest way managing fans depending on damper position.

3 - Spring return damper

Motorized Damper with spring return servomotor fitted on the top directly controlled by the unit. The unit controls the damper in the safest way managing fans depending on damper position. In case of power failure, the spring return allows the damper to close, therefore avoiding air passing through a not working unit.

4 - Bottom Air Intake

The unit is configured with the bottom part open and the frontal panel blacked in order to allow the air stream from the bottom to the top of the unit. Filter positioning doesn't need to be changed and the unit guarantee easily access from the front of it.

5 - Alarm card

The unit shall be fitted with alarm card to allow remote monitoring through electrical signals of most important alarms (up to 6), for monitoring working conditions or events (failure). The outputs (all together) can be set to N.O. (normally open) or N.C. (normally closed).

6 - Pressure control

Pressure control transducer control fan speed for keeping constant the static pressure.

In case of multiple units are connected in teamwork, they share pressure sensor data to provide greater flexibility, visibility and control. User can decide to control the fans on the average reading collected in the U2U network. In case of failure, system can work until only one sensor is available.

7 - Ethernet Switch

Ethernet Switch with 5 RJ45 ports shall be installed in the electrical panel. The device needs to include LED indicators for an easier use.

8 - Main Switch on the frontal Panel

The switch shall be accessible from the front of the unit with the door closed and prevent access to the high-voltage electrical components unit switched to the off positioning. The manual disconnect switch shall be mounted in the high-voltage section of the electrical panel.

9 - Phase Detector

The device monitoring 3-phase and in case of incorrect phase sequence, total and partial phase loss.

10 - Smart Aisle™

The unit shall be ready for containment control (Smart Aisle™). The unit should have the capability to modulate airflow according to the airflow taken by the servers, using remote temperature sensor as controlling sensor, installed in the top part of the aisle which communicate between the aisle through a calibrated hole. This guarantee to maximize the system efficiency providing to the server only airflow needed. The valve shall be modulated according to the unit air supply temperature in order to optimize server inlet temperature.

The system done by multiple units shall work with efficient cascade way, trying to maximize energy efficiency always working where EC Fans are more effective.

The unit is equipped by default with a special switch that allows to change easily three different working mode:

- automatic control of airflow and cooling
- unit forced to off mode
- airflow and cooling forced to 100%

11 - Cooling Override

During control reboot due to a power outage or in case of control failure, the cooling continuity is guaranteed without any capacitors or battery backup. A specific algorithm permits to operate at specific fans speed and keeping the chilled water valve to the last position. Once the communication has been re-established, the valve and fans control are released to normal operation. This feature is not available for units with damper(s).

12 - Super Saver

The Supersaver function permit a network between indoor and outdoor units in order to maximize chiller freecooling operation.

Whenever possible the system will automatically raise water temperatures as thermal loads fall, aligning cooling capacity with demand, thus increasing system efficiency and freecooling operation of the chillers. The increase of the water temperature will never impact the unit supply air temperature threshold, in order to guarantee the right temperature in front of the technical equipment's. This feature is available with all the chillers which implement this feature and can communicate with the indoor units.

13 - Energy meter

Energy meter with Modbus connection ports shall be installed in the electrical panel. The device has LED display for easier use. Measure only total power consumption of the PCW unit.

Measurement accuracy:

- Voltage: $\pm 0.5\%$ (50...720VAC)
- Current: $\pm 0.5\%$ (0.1...1.1 In)
- Power: $\pm 1\%$ f.s.
- Frequency: $\pm 0.05\%$
- Active energy: Class 1 (IEC/EN 62053-21)
- Reactive energy: Class 2 (IEC/ EN62053-23)

Functions and measurements:

- Voltage: phase, line and phase to neutral
- Phase current (calculated neutral current)
- Power: apparent, active, reactive per phase and total
- Phase and total power factor
- Frequency
- Maximum, average and minimum values for all measurements
- Maximum power and current demand Voltage and current asymmetry
- Voltage and current harmonics up to the 15th order
- Total harmonic distortion (THD) of voltages and currents
- Partial and total active, reactive and apparent energy meters (phase and system)
- Programmable partial and total hour counters
- Phase active power unbalance



Fabbricante - Manufacturer - Hersteller - Fabricant - Fabricante Fabricante - Tillverkare - Fabrikant - Valmistaja - Produzent Fabrikant
- Κατασκευαστής - Producent
Vertiv S.r.l. - Zona Industriale Tognana
Via Leonardo da Vinci, 16/18 - 35028 Piove di Sacco - Padova (Italy)

Il Fabricante dichiara che questo prodotto è conforme alle direttive Europee:

The Manufacturer hereby declares that this product conforms to the European Union directives:

Der Hersteller erklärt hiermit, dass dieses Produkt den Anforderungen der Europäischen Richtlinien gerecht wird: Le Fabricant déclare que ce produit est conforme aux directives Européennes:

El Fabricante declara que este producto es conforme a las directivas Europeas:

O Fabricante declara que este produto está em conformidade com as directivas Europeias: Tillverkare försäkrar härmed att denna produkt överensstämmer med Europeiska Unions direktiv: De Fabrikant verklaart dat dit produkt conform de Europese richtlijnen is:

Vaimistaja vakuuttaa täten, että tämä tuote täyttää seuraavien EU-direktiivien vaatimukset: Produzent erklærer herved at dette produktet er i samsvar med EU-direktiver:

Fabrikant erklærer herved, at dette produkt opfylder kravene i EU direktiverne:

Ο Κατασκευαστής δηλώνει ότι το παρόν προϊόν είναι κατασκευασμένο σύμφωνα με τις οδηγίες της Ε.Ε.:

2006/42/EC; 2014/30/EU; 2014/35/EU; 2014/68/EU; 2011/65/EU; EU/2015/863



VertivCo.com | Vertiv - EMEA, via Leonardo Da Vinci 16/18, Zona Industriale Tognana, 35028 Piove di Sacco (PD) Italy, Tel: +39 049 9719 111, Fax: +39 049 5841 257

© 2024 Vertiv Co. All rights reserved. Vertiv, the Vertiv logo and Vertiv Liebert PCW are trademarks or registered trademarks of Vertiv Co. All other names and logos referred to are trade names, trademarks or registered trademarks of their respective owners. While every precaution has been taken to ensure accuracy and completeness herein, Vertiv Co. assumes no responsibility, and disclaims all liability, for damages resulting from use of this information or for any errors or omissions. Specifications are subject to change without notice.