

Liebert® PCW

Chilled Water Perimeter Unit PW Models Standard & Extended Height

Product Documentation

English, 10015453MAN_ENG, rev. J.1 - 16.01.2024

This document, written in English, is the original version



Contents

| | | | |
|---|----------|--|-----------|
| 1. Digit Nomenclature | 1 | 4.3 Chilled Water System..... | 13 |
| 2. Highlights | 3 | 4.4 Air System..... | 16 |
| 2.1 Liebert® PCW..... | 3 | 4.5 Electric System..... | 24 |
| 2.2 Efficiency..... | 4 | 4.6 Control System..... | 27 |
| 2.3 Cooling Continuity..... | 4 | 5. Technical Data | 31 |
| 2.4 Unique Flexibility..... | 4 | 5.1 Performances..... | 31 |
| 2.5 Smart Control..... | 5 | 5.2 Valve..... | 35 |
| 3. Intended Use | 7 | 5.3 Fan..... | 48 |
| 3.1 Purpose of the Unit..... | 7 | 5.4 Water Connections..... | 49 |
| 3.2 Heat transfer Fluid..... | 7 | 5.5 Water Temperature Sensors & Flow Meter (option)..... | 49 |
| 3.3 Environment..... | 7 | 5.6 Energy Meter (optional)..... | 49 |
| 3.4 Reference Norms..... | 8 | 6. Sound Pressure Level | 51 |
| 4. Technical Specification | 9 | 6.1 Introduction..... | 51 |
| 4.1 Versions Overview..... | 9 | 6.2 Sound Emission Spectra..... | 51 |
| 4.2 Structure..... | 12 | 6.3 Plenum with Silencing Cartridges (Accessory)..... | 53 |

Annexes

| | |
|---|-----------|
| Annex A - Water Circuit Diagrams | 55 |
| Annex B - Dimensions and Weights | 59 |
| Annex C - Connections | 69 |
| Annex D - Accessories | 79 |
| Annex E - Additional Accessories | 83 |

Abbreviations - Acronyms

| Item | Definition |
|-----------------|------------------------------------|
| ATS | Automatic Transfer Switch |
| BMS | Building Management System |
| EC | Electronically Commutated [fans] |
| OPEX | OPerating EXpense |
| MCB | Miniature Circuit Breaker |
| STO | Safe Torque Off |
| Ultracap | Ultra capacitor |
| U2U | Unit to unit |
| PICV | Pressure Independent Control Valve |

1. Digit Nomenclature

The unit is fully defined by the following digits.

| | | | | | | | | | | | | | | | | | | | | | | | | |
|---|---|---|---|---|---|---|---|---|----|----|----|----|----|----|----|----|----|----|----|----|----|----|----|----|
| 1 | 2 | 3 | 4 | 5 | 6 | 7 | 8 | 9 | 10 | 11 | 12 | 13 | 14 | 15 | 16 | 17 | 18 | 19 | 20 | 21 | 22 | 23 | 24 | 25 |
|---|---|---|---|---|---|---|---|---|----|----|----|----|----|----|----|----|----|----|----|----|----|----|----|----|

| Dig. | Feature | Value | Description |
|-------|------------------------|-------|---|
| 1 2 | Family name | PCW | |
| 3 4 5 | Model | 000 | |
| 6 | Air discharge | U | Upflow |
| | | H | Downflow Frontal (displacement) |
| | | D | Downflow Up |
| | | E | Downflow Down (in the raised floor) |
| 7 | Cooling system | L | Legacy coil |
| | | S | Smart Efficiency coil |
| | | E | Eco coil |
| | | W | Legacy Dual Circuit |
| 8 | Fan | E | EC fan - High Efficiency |
| | | P | EC fan - High Power |
| 9 | Power supply | 3 | 400 V / 3 ph / 50 Hz + N CE |
| | | T | 380-400 V / 3 ph / 60 Hz + N CE |
| | | 6 | 460 V / 3 ph / 60 Hz CE |
| 10 | Valve | 2 | CW two way valve |
| | | 3 | CW three way valve |
| | | P | CW two way valve Pressure independent |
| 11 | Humidification | 0 | None |
| | | H | Infrared humidifier |
| | | U | Ultrasonic humidifier |
| | | S | Electrode humidifier |
| 12 | Microprocessor control | 0 | None |
| | | 7 | 7" touch screen |
| | | F | 10" touch screen |
| 13 | Heating and re-heating | 0 | None |
| | | 1 | Electric heating standard capacity |
| | | 2 | Electric heating high capacity |
| | | 4 | Hot water heating |
| | | 8 | Electric heating standard capacity + hot water heating |
| 14 | Air filter | 1 | External filter module |
| | | 2 | External filter module + Diff. pressure transducer |
| | | 3 | External filter module + Clogged filter sensor |
| | | 4 | External filter module (PW400 only) |
| | | 5 | External filter module + Diff. pressure transducer (PW400 only) |
| | | 6 | External filter module + Clogged filter sensor (PW400 only) |

| Dig. | Feature | Value | Description |
|------|----------------------|-------|---|
| 15 | Coils and pipes | H | Bottom connectors |
| | | T | Top connectors |
| | | S | Left side connectors |
| | | C | Bottom connections (PW400 only) |
| 16 | Color | 1 | Black RAL 7021 |
| 17 | High voltage option | D | Standard Power Supply |
| | | F | Dual Power Supply Parallel |
| | | A | Dual Power Supply with ATS |
| | | G | Dual Power Supply with ATS and Ultracap |
| 18 | Package option | 0 | None |
| | | S | Predisposition for Smart Aisle™ (predisposition for damper sensor, 3 position switch) |
| | | F | Predisposition for Economizer (sensors, predisposition for dampers) |
| | | G | Predisposition for Smart Aisle™ + Economizer |
| 19 | Monitoring | 0 | None |
| | | 1 | Monitoring (Modbus IP, BACnet IP, SNMP and HTTP) |
| | | 4 | LIFE compatibility |
| 20 | Options | 0 | None |
| | | C | Condensate pump |
| | | E | Energy meter |
| | | R | Condensate pump + Energy meter |
| 21 | Packaging | P | PLP and Pallet |
| | | C | PLP and wooden crate |
| | | S | Seaworthy |
| 22 | Water sensor | 0 | None |
| | | W | Water temperature sensor IN/OUT |
| | | V | Water temperature sensor IN/OUT and flow meter |
| 23 | EMC Emissions | R | IEC61000-6-3 Compliant |
| | | I | IEC61000-6-4 Compliant |
| 24 | Free digit | E | Free |
| 25 | Special Requirements | A | Standard Vertiv™ |
| | | X | Special Vertiv™ |

Fan module

The fan module can be delivered separately:

- always for extended height units
- in case of fan module replacement for standard units (with the exception of the 1 bay units)

The fan modules are not available for 1 bay units, since the fan section of these units are integrated with the cabinet structure.

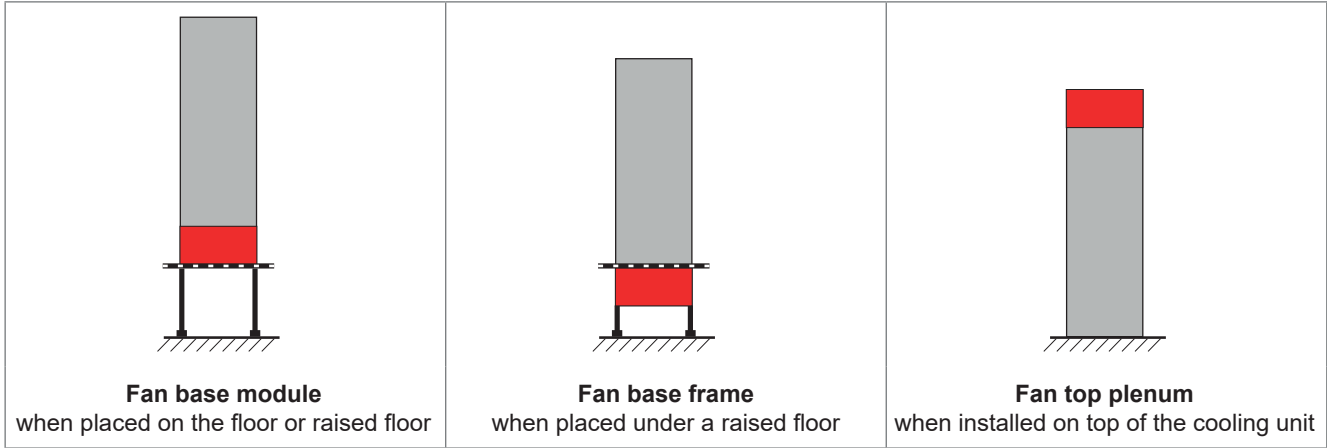

The unit is fully defined by the following digits.

| | | | | | | | | | | | | |
|---|---|---|---|---|---|---|---|---|----|----|----|----|
| 1 | 2 | 3 | 4 | 5 | 6 | 7 | 8 | 9 | 10 | 11 | 12 | 13 |
|---|---|---|---|---|---|---|---|---|----|----|----|----|

| Dig. | Feature | Value | Description |
|-------|---------------------------------|------------|------------------------------------|
| 1 2 3 | Fan module (see the gure above) | BMW | Fan base module |
| | | BFW | Fan base frame |
| | | TPW | Fan top plenum |
| 4 5 | Size: nominal length | 12 | 1200 mm |
| | | 17 | 1750 mm |
| | | 20 | 2050 mm |
| | | 25 | 2550 mm |
| | | 29 | 2950 mm |
| | | 33 | 3350 mm |
| 6 | Air delivery | 38 | 3850 mm (PW400 only) |
| | | S | Standard |
| | | B | Back (fans removal from the front) |
| 7 | Fans | F | Front |
| | | E | EC fan advance - HE |
| | | P | EC fan advance - HP |

| Dig. | Feature | Value | Description |
|------|----------------------|----------|---------------------------------|
| 8 | Heaters | 0 | No HEATERS |
| | | 1 | Standard capacity |
| | | 2 | High capacity |
| 9 | Packaging | P | PLP and Pallet |
| | | C | PLP and wooden crate |
| | | S | Seaworthy |
| 10 | Power supply | 3 | 400 V / 3 ph / 50 Hz + N CE |
| | | T | 380-400 V / 3 ph / 60 Hz + N CE |
| | | 6 | 460 V / 3 ph / 60 Hz CE |
| 11 | Options | 0 | None |
| | | C | Condensate pump |
| 12 | Free digit | | |
| 13 | Special requirements | A | Standard Vertiv™ |
| | | X | Special Vertiv™ |

2. Highlights

Content of this chapter

| | | | |
|-----------------------------|---|-----------------------------|---|
| 2.1 Liebert® PCW..... | 3 | 2.4 Unique Flexibility..... | 4 |
| 2.2 Efficiency..... | 4 | 2.5 Smart Control..... | 5 |
| 2.3 Cooling Continuity..... | 4 | | |

2.1 Liebert® PCW

| | |
|---------------------------|---|
| Efficiency | Liebert® PCW , thanks to its well-established design, minimizes running costs for the entire cooling system. All components and control strategies are enhanced to provide an extremely efficient solution for infrastructures facing the challenges of modern IT applications. |
| Cooling Continuity | Liebert® PCW , due to new advanced technologies, matches requirements for cooling continuity coming from the most trusted and approved certification authorities for data center design and operation. The Liebert® PCW ensures precise and constant control of airflow, temperature, and humidity under all working conditions. Cooling continuity and reliability are key factors for Liebert® PCW and mission critical infrastructures. |
| Unique Flexibility | Liebert® PCW adapts perfectly to each data center's room air condition and water temperature requirement. A wider operating range allows users to remain a step ahead of new challenges posed by data center requirements and climate change. Liebert® PCW is an extremely flexible unit able to adapt to different site needs. |
| Smart Control | Liebert® PCW uses algorithms developed and perfected over fifty years of business experience and comes now with a new 7" touch screen display for quicker and easier data readability. |

2.2 Efficiency

| | |
|---|--|
| Aerodynamic design | The unit design minimizes the aerodynamic impact of all the internal parts; any detail like coil shape, coil size, coil angle, electrical panel design, fan separator has been optimized, ensuring a dramatically reduced internal air pressure 10% that immediately becomes a benefit in terms of reduced unit power consumption. |
| EC Fan latest evolution | As result of the latest evolution of the EC fans technology, unit energy efficiency improves; utilizing powerful fans, unit cooling capacity increases more than 5% at the same unit footprint. |
| Pressure Independent control valve | Pressure independent control valves regulate and maintain a constant flow to the unit as water pressure in the system varies. Delivering better water distribution and thus, increasing overall system energy efficiency. |
| Certified performance by an external independent association | Eurovent certified performance guarantees independent testing, thus delivering rating accuracy and enhancing the unit's reliability. The new IT Cooling program updates performance tolerance, introducing stricter values than previous one. Checks ongoing Eurovent certification validity: www.eurovent-certification.com |

2.3 Cooling Continuity

| | |
|---------------------------|---|
| Dual Circuit | Dual circuit units integrate in the same frame two independent chilled water circuits, which can be connected to two different water loops. In case the first circuit fails, the second one can substitute and provide the necessary cooling back up. |
| Cooling Override | The cooling override function is the best answer to increase the unit reliability, in case of control failure and during the re-booting time, limiting cooling interruption to the IT equipment. |
| Airflow Continuity | The airflow continuity is guaranteed until the last unit fan is able to run. |
| Redundant Sensor | In case of control sensor failure, the unit automatically adapts in order to grant the necessary cooling/airflow continuity. A redundant sensor can be installed and activated only if the first one is breaks or missing. |

2.4 Unique Flexibility

| | |
|---|---|
| Multiple enhanced coils | Multiple enhanced coils permit to best suit the different market trends, in terms of room air conditions and water temperature requirements, adapting perfectly to each data center's working condition. |
| Perfect layout adaptability | More than 4 airflow configurations, chilled water connections provided in three different positions with different terminals allow the units to adapt to any data center layout and configuration. |
| Dual power supply | Electrically, units can be fed with two power sources combined with an ATS for full back-up or with two separate lines, one for the main devices and the other for the auxiliaries. Control power continuity can keep the CPU and BMS on for at least 1 minute during a power outage. |
| Wide range of working conditions | The maximum return air working temperature is up to 45°C, this permits the infrastructures facing the challenges of modern IT applications to develop an extremely efficient environment. |

2.5 Smart Control

| | |
|--------------------------|--|
| Teamwork | Ready for Teamwork of up to 32 units with optimization based on installation type, furthermore it allows for advanced control functionality (sharing sensor's data, standby rotation, lead-lag, cascade operation and rotating master function). |
| iCOM™ | The Liebert® iCOM™ software embeds a comprehensive algorithms library with more than 10 different strategies to control temperature/humidity & airflow developed for adapting perfectly to the different Data Center solutions. |
| Virtual Display | A Virtual Display can replicate, through a web browser, all the functionalities of the standard display, either remotely or connecting a laptop on the ethernet port directly to the frontal door. |
| Energy Monitoring | Unit power consumptions and cooling gross capacity can be calculated thanks to specific algorithms and the direct communication between the control, sensors and the EC fans motor. This allows the monitoring of the unit energy efficiency through the BMS system. |

3. Intended Use

Content of this chapter

| | |
|--------------------------------|---------------------------------------|
| 3.1 Purpose of the Unit.....7 | 3.3.2 Operating conditions.....7 |
| 3.2 Heat transfer fluid.....7 | 3.3.3 Water supply requirements.....8 |
| 3.3 Environment.....7 | 3.4 Reference Norms.....8 |
| 3.3.1 Storage conditions.....7 | |

3.1 Purpose of the Unit

The **Liebert® PCW** units have been designed and manufactured for the following purpose:

- Precision air conditioning for indoor use (for data centers, network closets, technological rooms).

3.2 Heat transfer fluid

The **Liebert® PCW** units are designed for use with water or water-glycol mixture. Water quality has to be in accordance with VDI 2035. The water glycol mixtures are used as medium for heat transfer where chiller is placed outside the building and outdoor temperature is below the freezing point of water. It's possible to use up to 50% water-glycol mixtures. See details in **Liebert® PCW User manual**.

3.3 Environment



WARNING

Do not use in explosive, acid or anyway aggressive atmosphere.

3.3.1 Storage conditions

Table 01 - Ambient conditions for storage

| | |
|----------------------------|--|
| Storage environment | Indoor environment, protected against weather agents. Clean (no dust), well-ventilated, non-condensing |
| Ambient temperature | -20°C / +50°C |
| Ambient humidity | <90% and preventing condensation |
| Storage time | The total storage time should not exceed six months. If the storage time is longer than six months, then you must check the functionality of sensors and other electronic devices before putting in operation the unit. |
| Position | Keep the unit vertically upright. |

3.3.2 Operating conditions

Table 02 - Ambient conditions for operation

| | | |
|---|---|---------------------------|
| Operating environment | The unit is designed for indoor installation, protected from weather agents, with the following ambient conditions. | |
| Air returning to the unit inlet (indoors conditions) | Temperature | +18°C — +45°C |
| | Absolute humidity | 5,5 — 11 g steam / kg air |
| | Relative humidity | 20 — 60% |
| Chilled water system | A very low thermal load will cause inaccurate temperature and humidity control | |
| | Minimum water inlet temperature | 5°C |
| | Maximum water pressure | 16 bar |
| | Water-Glycol mixture limit | Up to 50% vol. |

| | | |
|------------------------------------|---------------------------------|---------|
| Hot water system (optional) | Maximum water inlet temperature | 85°C |
| | Maximum water pressure | 8,5 bar |
| Power supply tolerance | Voltage | ± 10% |
| | Frequency | ± 2 Hz |

See also the *User Manual*

3.3.3 Water supply requirements

NOTE The following instructions refer both to chilled water and to hot water



Analyze the water It is the user's responsibility to establish the quality of the water and make sure that this is compatible with the materials used in the exchangers. The quality of water may significantly affect the operation and the life of the exchangers. The first step in the planning the treatment of the water is chemical analysis, which must be performed by qualified personnel from specialist organizations. Water quality has to be in accordance with VDI 2035.

Add water softeners In tower water, the tendency to form deposits may be high: to reduce this phenomenon, there are various types of water softening treatments available, including the use of ion exchange resins.

| | | | | | | | | | | | | | | | | | | | | | | | | | | | | | | | | | | | | | | | | | | | | |
|---------------------------------------|---|-----------|---|-----------|-----|-----------|-----------------------|-----|-------|---------------------------------------|-----|------|-----------------------|----|-----------|-----------------------|-----|------|------------------------------------|-----|-------|-----------------------|-----|-------|----------------------|-----|-------|------------------------|-----|-------|------------------------|-----|--------|-----------------------|-----|------|-----------------------|-----|------|--------------------|----|------|------------------------------|-----|
| Prevent corrosion | The oxygen dissolved in water increases the rate of corrosion. The main factors causing corrosion are sulphur and carbon dioxide acids (see the Langelier and Ryznar indices). A combined effect of fouling due to dust and organic material provides a support for bacteria, fungi and algae; the growth of organisms may produce an oxygen gradient and this results in rather severe pitting of the metallic surface. The phenomenon of corrosion is obviously related to the material used on the liquid side of the heat exchanger. The table on the right shows the reference values for corrosion on copper, these values must be considered as guidelines to avoid corrosion. | | | | | | | | | | | | | | | | | | | | | | | | | | | | | | | | | | | | | | | | | | | |
| | | | <table border="1"> <tr><td>pH</td><td>---</td><td>7,5 – 9,0</td></tr> <tr><td>SO₄</td><td>ppm</td><td>< 100</td></tr> <tr><td>HCO₃/SO₄</td><td>---</td><td>> 10</td></tr> <tr><td>Total hardness</td><td>dH</td><td>4,5 – 8,5</td></tr> <tr><td>Cl⁻</td><td>ppm</td><td>< 50</td></tr> <tr><td>PO₄³⁻</td><td>ppm</td><td>< 2,0</td></tr> <tr><td>NH₃</td><td>ppm</td><td>< 0,5</td></tr> <tr><td>Free chlorine</td><td>ppm</td><td>< 0,5</td></tr> <tr><td>Fe³⁺</td><td>ppm</td><td>< 0,5</td></tr> <tr><td>Mn⁺⁺</td><td>ppm</td><td>< 0,05</td></tr> <tr><td>CO₂</td><td>ppm</td><td>< 50</td></tr> <tr><td>H₂S</td><td>ppm</td><td>< 50</td></tr> <tr><td>Temperature</td><td>°C</td><td>< 65</td></tr> <tr><td>O₂ content</td><td>ppm</td><td>< 0,1</td></tr> </table> | pH | --- | 7,5 – 9,0 | SO₄ | ppm | < 100 | HCO₃/SO₄ | --- | > 10 | Total hardness | dH | 4,5 – 8,5 | Cl⁻ | ppm | < 50 | PO₄³⁻ | ppm | < 2,0 | NH₃ | ppm | < 0,5 | Free chlorine | ppm | < 0,5 | Fe³⁺ | ppm | < 0,5 | Mn⁺⁺ | ppm | < 0,05 | CO₂ | ppm | < 50 | H₂S | ppm | < 50 | Temperature | °C | < 65 | O₂ content | ppm |
| pH | --- | 7,5 – 9,0 | | | | | | | | | | | | | | | | | | | | | | | | | | | | | | | | | | | | | | | | | | |
| SO₄ | ppm | < 100 | | | | | | | | | | | | | | | | | | | | | | | | | | | | | | | | | | | | | | | | | | |
| HCO₃/SO₄ | --- | > 10 | | | | | | | | | | | | | | | | | | | | | | | | | | | | | | | | | | | | | | | | | | |
| Total hardness | dH | 4,5 – 8,5 | | | | | | | | | | | | | | | | | | | | | | | | | | | | | | | | | | | | | | | | | | |
| Cl⁻ | ppm | < 50 | | | | | | | | | | | | | | | | | | | | | | | | | | | | | | | | | | | | | | | | | | |
| PO₄³⁻ | ppm | < 2,0 | | | | | | | | | | | | | | | | | | | | | | | | | | | | | | | | | | | | | | | | | | |
| NH₃ | ppm | < 0,5 | | | | | | | | | | | | | | | | | | | | | | | | | | | | | | | | | | | | | | | | | | |
| Free chlorine | ppm | < 0,5 | | | | | | | | | | | | | | | | | | | | | | | | | | | | | | | | | | | | | | | | | | |
| Fe³⁺ | ppm | < 0,5 | | | | | | | | | | | | | | | | | | | | | | | | | | | | | | | | | | | | | | | | | | |
| Mn⁺⁺ | ppm | < 0,05 | | | | | | | | | | | | | | | | | | | | | | | | | | | | | | | | | | | | | | | | | | |
| CO₂ | ppm | < 50 | | | | | | | | | | | | | | | | | | | | | | | | | | | | | | | | | | | | | | | | | | |
| H₂S | ppm | < 50 | | | | | | | | | | | | | | | | | | | | | | | | | | | | | | | | | | | | | | | | | | |
| Temperature | °C | < 65 | | | | | | | | | | | | | | | | | | | | | | | | | | | | | | | | | | | | | | | | | | |
| O₂ content | ppm | < 0,1 | | | | | | | | | | | | | | | | | | | | | | | | | | | | | | | | | | | | | | | | | | |

3.4 Reference Norms

All **Liebert® PCW** thermal units are designed, manufactured and tested according to the following directives and standards:

| | |
|--|---|
| EU Directives | <ul style="list-style-type: none"> Machine Directive 2006/42/CE PED Directive 2014/68/EU Low Voltage Directive 2014/35/UE EMC Directive 2014/30/UE RoHS II Directive 2011/65/EU RoHS III Directive EU/2015/863 |
| CE Marking and Conformity Declaration | <p>The units are marked "CE".</p> <p>Each unit is supplied complete with individual test certificate and a certificate of conformity to the European Union Directives.</p> <p>See also the last page.</p>  |
| UKCA Marking and Conformity Declaration | <p>The units are marked "UKCA".</p> <p>Each unit is supplied complete with individual test certificate and a certificate of conformity to the UK Safety Regulations</p>  |
| Performance test norms | <ul style="list-style-type: none"> Cooling Capacity according to EN 14511 Sound Power Level according to ISO 3744 |

4. Technical Specification

Content of this chapter

| | | | |
|---|----|--|----|
| 4.1 Versions Overview..... | 9 | 4.5 Electric System..... | 24 |
| 4.1.1 Unit frame..... | 9 | 4.5.1 Electric panel..... | 24 |
| 4.1.2 Air Distribution..... | 10 | 4.5.2 Standard or dual power supply..... | 25 |
| 4.1.3 Cabinet size..... | 11 | 4.5.3 EMC Emission..... | 26 |
| 4.2 Structure..... | 12 | 4.6 Control System..... | 27 |
| 4.3 Chilled Water System..... | 13 | 4.6.1 Control system and display..... | 27 |
| 4.3.1 Circuit version versions and operating principle..... | 13 | 4.6.2 Teamwork..... | 28 |
| 4.3.2 Water coil types..... | 14 | 4.6.3 Smart Aisle™..... | 29 |
| 4.3.3 Water valve types..... | 15 | 4.6.4 Cooling override (optional)..... | 29 |
| 4.4 Air System..... | 16 | 4.6.5 Super Saver (optional)..... | 30 |
| 4.4.1 Fans..... | 16 | 4.6.6 Monitoring (optional)..... | 30 |
| 4.4.2 Filters..... | 16 | | |
| 4.4.3 Electrical reheating/heating..... | 21 | | |
| 4.4.4 Humidifier (optional)..... | 22 | | |

4.1 Versions Overview

4.1.1. Unit frame

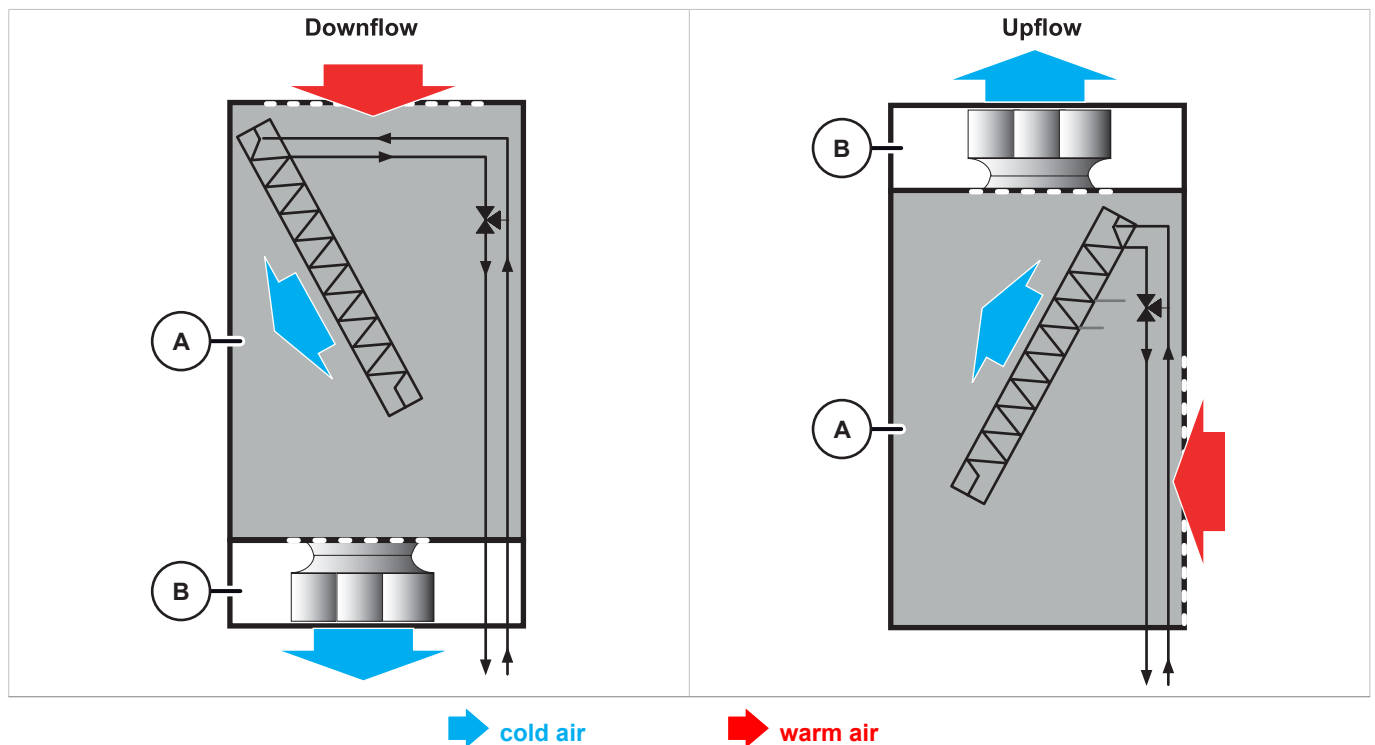

The unit frame is made by the coil section [A] and the fan section [B].

The coil section contains the refrigerating system of the unit (compressor, evaporator, expansion valve, liquid receiver, accessories), the electric panel and the control system.

The fan takes the **warm air** from the room into the unit. The air flows through the evaporator, cools down and blows out again in the room. The fan section may be placed at the bottom of the coil section (**Downflow versions**) or on top (**Upflow versions**).





The refrigerating system of the unit is connected on site to the external remote condenser [C] (which must be purchased separately).

The unit frames can be combined in different ways to obtain different versions. Different versions are available also for the refrigerating system.







4.1.2 Air distribution

The unit is placed on a raised floor, whereas the unit fan module can be placed under a raised floor. The air flow direction can be either **Upflow** (fan section on top) or **Downflow** (fan section at the bottom).

For **Standard Units** the following combinations are available:

| | | | |
|---|--|---|---|
| <p style="text-align: center;">U - Upflow</p>  <p>The unit takes the air from the front and deliver from the top. The unit is suited for ducted application. The unit can be installed with and without a raised floor. The bottom of the unit is closed.</p> | <p style="text-align: center;">H - Downflow Frontal</p>  <p>The unit takes the air from the top and deliver from the front through a grill on the front panel(s). The unit shall be installed directly on the floor, the bottom of the unit is closed.</p> | <p style="text-align: center;">D - Downflow Up</p>  <p>The unit takes the air from the top and deliver from the bottom, with fans running on the raised floor.</p> | <p style="text-align: center;">E - Downflow Down</p>  <p>The unit takes the air from the top and deliver from the bottom, with fans running in the raised floor. Delivering the air on all the directions permit to optimize unit efficiency. The unit is suited for raised floor air delivery.</p> |
|---|--|---|---|

For **Extended Units** the following combinations are available:

| | | | |
|--|--|--|--|
| <p style="text-align: center;">U - Upflow + TP</p>  <p>The unit takes the air from the front and deliver from the top. The unit is suited for ducted application. The unit can be installed with and without a raised floor. The bottom of the unit is closed.</p> | <p style="text-align: center;">D - Downflow Up + BM - S</p>  <p>The unit takes the air from the top and deliver from the bottom, with fans running on the raised floor.</p> | <p style="text-align: center;">D - Downflow Up + BM - B</p>  <p>The unit takes the air from the top and deliver from the back of the fan module, with fans running on the raised floor.</p> | <p style="text-align: center;">D - Downflow Up + BM - F</p>  <p>The unit takes the air from the top and deliver from the front of the fan module, with fans running on the raised floor.</p> |
| <p style="text-align: center;">E - Downflow Down + BF - S</p>  <p>The unit takes the air from the top and deliver from the bottom, with fans running in the raised floor. Delivering the air on all the directions permit to optimize unit efficiency. The unit is suited for raised floor air delivery.</p> | <p style="text-align: center;">E - Downflow Down + BF - B</p>  <p>The unit takes the air from the top and deliver from the bottom, with fans running in the raised floor. Delivering the air from the back of the fan module. The unit is suited</p> | | |

4.1.3 Cabinet size

Frame and panels

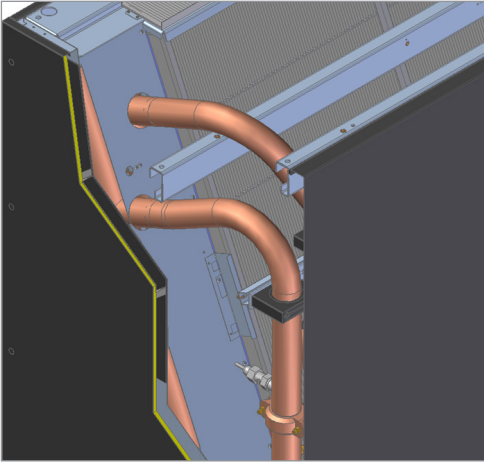

The cabinet is manufactured from hot-dipped galvanized steel sheet, externally painted with Black RAL 7021 colour epoxy polyester powder paint and assembled using stainless steel and galvanized screws and high tensile rivets. All the zinc sheet metals parts are hot dip galvanized or powder coated in order to minimize any harmful zinc whiskers.

The rear and the fans section panels are double-skinned, with 20 mm (frontal fan section panel with 40 mm) Class A1 EU fireproof insulation sandwiched between the skins to reduce noise emission and heat loss. The side panels, which are isolated from the inside of the unit to form a complete double-skinned cabinet, the small service panel for electrical heaters, are also lined with 10 mm Class A1 EU fireproof insulation.

The frontal panel(s) are supported by hinges to allow for an easier access; this panel can be opened by the fast closing lock. The rear and side panels are screwed to the supports. The rear panel(s) are screwed directly to the frame.

4.2 Structure

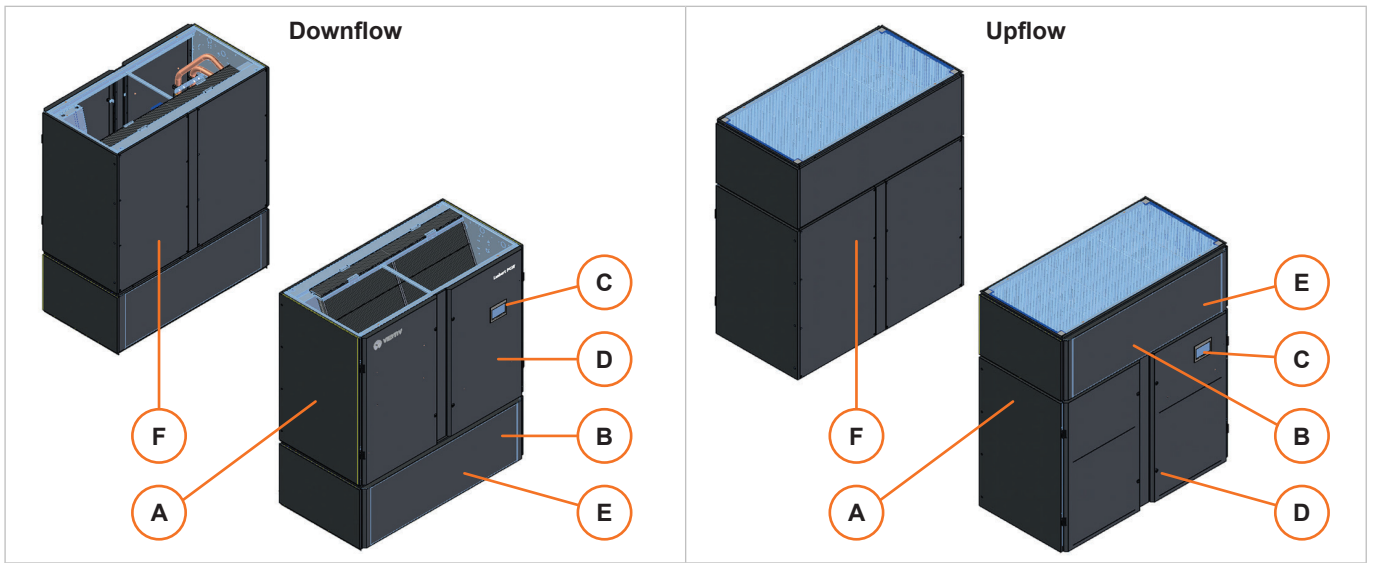

| Ref. | Description | Remarks |
|------|------------------------|---|
| A | Coil section | The coil section is completely closed by panels and by the door for protection against any contact with electric parts and hot or cold surfaces. |
| B | Fan section | The fan section is completely closed by panels and grids for protection against any contact with moving parts. |
| C | Control panel | The unit is usually controlled remotely by a network connection. The control panel is optional and may be placed on the front door or inside the front door. |
| D | Doors | The doors can be opened only by the proper tool. |
| E | Fan safeguards | The fixed panels (safeguards) can be removed only by loosening the fixing screws. |
| F | Rear safeguards | |

After opening the doors:

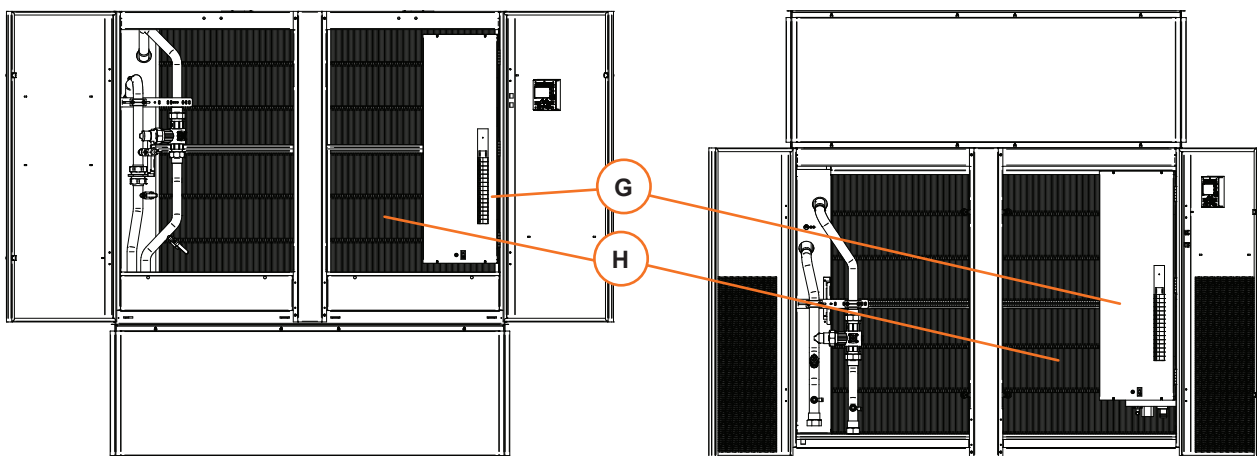

| Ref. | Description | Remarks |
|------|--|--|
| G | Electric and control panel safeguards | The fixed safeguards can be removed only by loosening the fixing screws. |
| H | Coil compartment | |

4.3 Chilled Water System

4.3.1 Circuit versions and operating principle

The Liebert® PCW product family includes two cooling system versions.

Single circuit

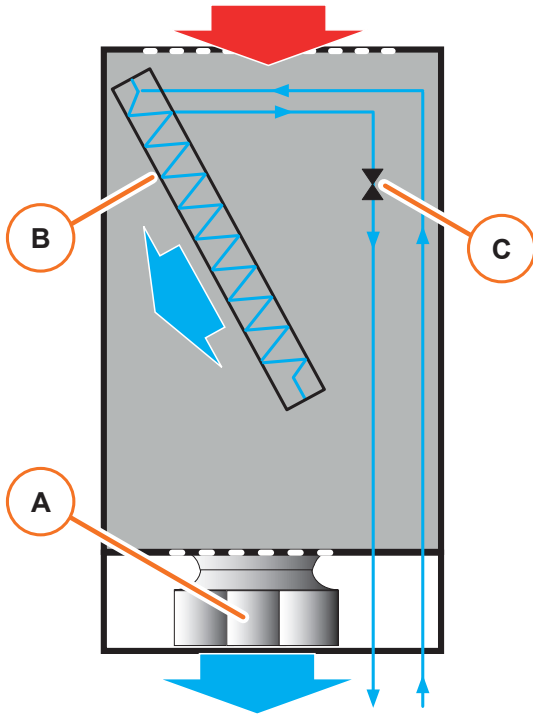

One chilled water circuit incorporating copper pipes; a modulating, motorized valve; air relief valve and drain valves.

| Main components | |
|-----------------|-------------|
| A | Fan |
| B | Water coil |
| C | Water valve |

Dual circuits

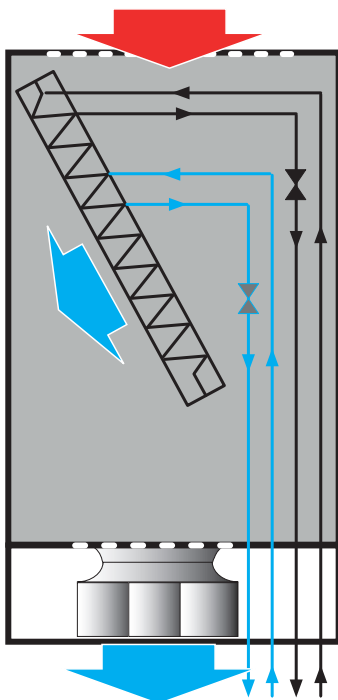

Two chilled water circuits incorporating copper pipes; a modulating, motorized valve; air relief valve and drain valves for each circuit.

Operating principle

These units shall be connected to chilled water circuits circuit failure, the second one can substitute the need for cooling capacity and provide the necessary back up. According to the controller settings the actuators can be managed in different ways.

Parallel mode: both valves are managed by the same input signal-always have the same position;

Cascade mode: until reached a threshold then also second valve will start to open second circuit;

Alternate mode: by external input or BMS signal you can choose which circuit (valve) will be on duty and which will be closed, only enabled circuit will have the valve driven according to the temperature proportional band. Both circuits provide the same cooling capacity.

4.3.2 Water coil types

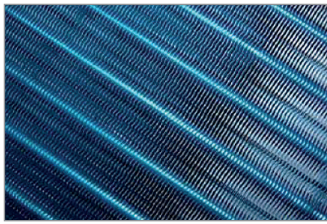

The inclined coil is manufactured from copper tubes and mechanically bonded to hydrophilic painted aluminum fins and is pressure tested to 30 bar. The large face area/low velocity coil allows precise control of temperature and humidity during cooling and dehumidification and is designed to optimize fluid velocity and minimize pressure drop, reaching the highest SHR value (Sensible Heat Ratio).

The hydrophilic coating shall significantly improve the speed of condensate drainage from the fins and shall provide superior water carryover resistance. One stainless steel condensate drain pan shall be provided.

| Unit models | Front Surface [m ²] | | Coil internal volume [liters] | | | |
|-------------|---------------------------------|--------------|-------------------------------|-----------------------------|---------------------------|----------------------------|
| | Single Circuit | Dual Circuit | "Legacy coil Single Circuit" | "Smart coil Single Circuit" | "Eco coil Single Circuit" | "Legacy coil Dual Circuit" |
| PW025 | 0,774 | | 13,9 | | 8,89 | |
| PW030 | 0,774 | | 14,4 | 15,82 | | |
| PW035 | 1,2 | | 16,71 | | 13,31 | |
| PW040 | 1,2 | 1.03 + 1.03 | 20,21 | 23,61 | | 11.96 + 11.96 |
| PW045 | 1,89 | | 26,51 | | 19,01 | |
| PW060 | 1,89 | 1.7 + 1.7 | 26,51 | 34,91 | 19,01 | 19.71 + 19.71 |
| PW070 | 2,26 | | 30,61 | | 24,31 | |
| PW080 | 2,26 | 2.09 + 2.09 | 36,91 | 43,31 | | 22.91 + 22.91 |
| PW095 | 2,88 | | 41 | | 33 | |
| PW110 | 2,88 | 2.68 + 2.68 | 49 | 57,1 | | 31.3 + 31.3 |
| PW145 | 3,4 | 3.2 + 3.2 | 67,3 | 65,6 | | 35.5 + 35.5 |
| PW170 | 3,92 | 3.72 + 3.72 | 75,8 | 74,2 | | 39.8 + 39.8 |
| PW046 | 1,75 | 1.5 + 1.5 | 27,66 | 29,54 | | 17.44 + 17.44 |
| PW066 | 2,76 | 2.49 + 2.49 | 38,76 | 46,56 | | 28.76 + 28.76 |
| PW091 | 3,31 | 3.06 + 3.06 | 54,06 | 63,36 | | 33.46 + 33.46 |
| PW136 | 4,21 | 3.91 + 3.91 | 71,6 | 83,4 | | 45.7 + 45.7 |
| PW161 | 4,97 | 4.67 + 4.67 | 98,3 | 98,5 | | 52 + 52 |
| PW201 | 5,73 | 5.43 + 5.43 | 110,8 | 110,9 | | 58.2 + 58.2 |
| PW400 | 2 x 5,73 | | 2 x 110,8 | 2 x 110,9 | | |

4.3.3 Water valve types

2-way valve

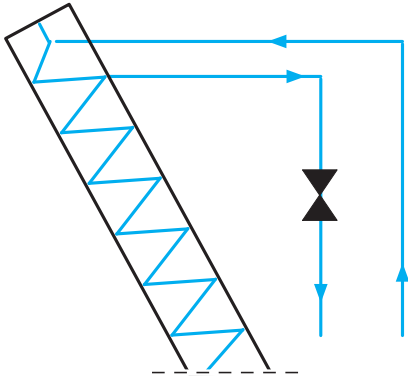

The unit is equipped with a chilled water circuit with a 2-way modulating valve, complete with motor for the control of water flow to the coil. The actuator is suitable for up to 1400 kPa closing pressure. The valve shall be designed for up to 1600 kPa water pressure.

3-way valve

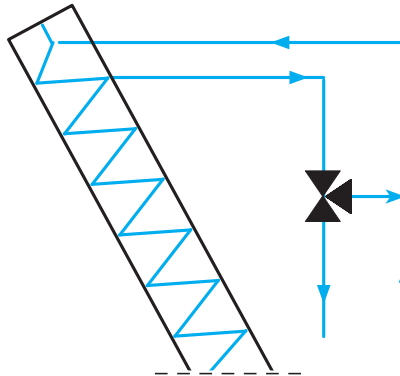

The unit is equipped with a chilled water circuit with a 3-way modulating valve, complete with motor for the control of water flow to the coil. The actuator is suitable for up to 1400 kPa closing pressure. The valve shall be designed for up to 1600 kPa water pressure.

PICV valve

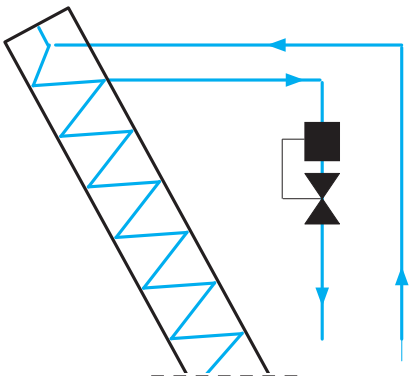

Pressure independent valves compensate for pressure variations, performing a continuous balancing function to maintain system performance at varying loads. The actuator is suitable for up to 1400 kPa closing pressure. The valve shall be designed for up to 1600 kPa water pressure.

Max. flow volume for PIC vavles

| | [l/s] |
|-------|--------|
| PW025 | 1.67 |
| PW030 | 1.67 |
| PW035 | 2.78 |
| PW040 | 2.78 |
| PW046 | 2.78 |
| PW045 | 6.3 |
| PW060 | 6.3 |
| PW066 | 6.3 |
| PW070 | 6.3 |
| PW080 | 6.3 |
| PW091 | 6.3 |
| PW095 | 12.6 |
| PW110 | 12.6 |
| PW136 | 12.6 |
| PW145 | 12.6 |
| PW161 | 12.6 |
| PW170 | 12.6 |
| PW201 | 12.6 |
| PW400 | 25.2 |

4.4 Air System

4.4.1 Fans

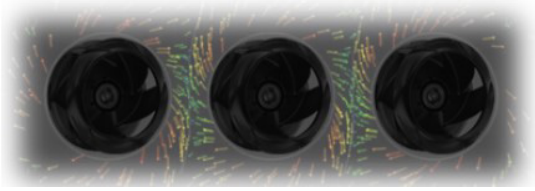

The unit is fitted with variable speed, high efficiency, single inlet, backward curved, centrifugal 'plug' type innovating EC fan(s). The fan(s) have an impeller with curved blades corrosion resistant. The fan motors are Electronically Commutated, IP54, with internal protections, continuous speed regulation via controller signal.

The fan wheel is statically and dynamically balanced of degree G6.3 according to ISO 21940-11:2016; the bearings are selflubricating.

A separator should be installed between the fans to eliminate turbulence effects of one fan to the others; it shall be also designed to increase efficiency compared to simple plate separators.

When the unit is equipped with more than one fan, the airflow is guaranteed until at least one fan will still be running, thus granting cooling continuity.

4.4.2 Filters

Standard filters

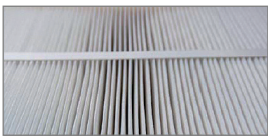

The standard filtration grade is ePM10 50% according to ISO/EN16890. The ePM10 50% standard filters are made by paper material and are completely recyclable.

The filter pleated structure gives high filtration efficiency, low pressure drops and allows the use of the filter without metallic or cardboard frame. The filter media is composed by fiber and latex. They are easily accessed/replaced by opening the front panel(s).

Filters are laying on the coil surface to maximize the filtering surface so reducing air pressure drop. On the top of the coil an L shape filter is placed to add more surface and to optimize coil exchange rate.

High efficiency filters (accessory)

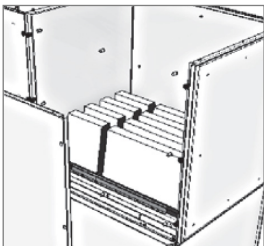

An extension hood with high efficiency air filter can be supplied on request and can be installed on top of the unit. It is available with 600mm height, it shall be the same design as the unit and consist of sandwich panels lined with non-flammable insulation material of class A1 EU, density 20 kg/m³.

Inside the hood optional high efficiency filters, filtration class ePM10 70%, ePM1 60% or ePM1 80% in accordance with the ISO/EN 16890 standard. The filters are made of fiberglass filter media. They are placed in "V" sections with a solid external frame in polypropylene and can withstand remarkable pressure and flow variations.

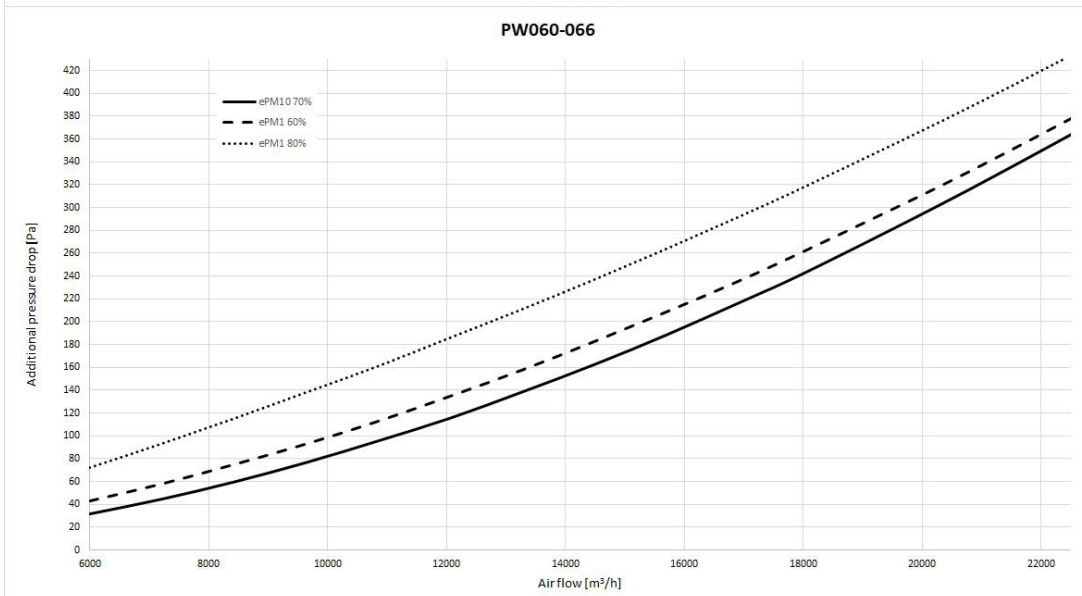
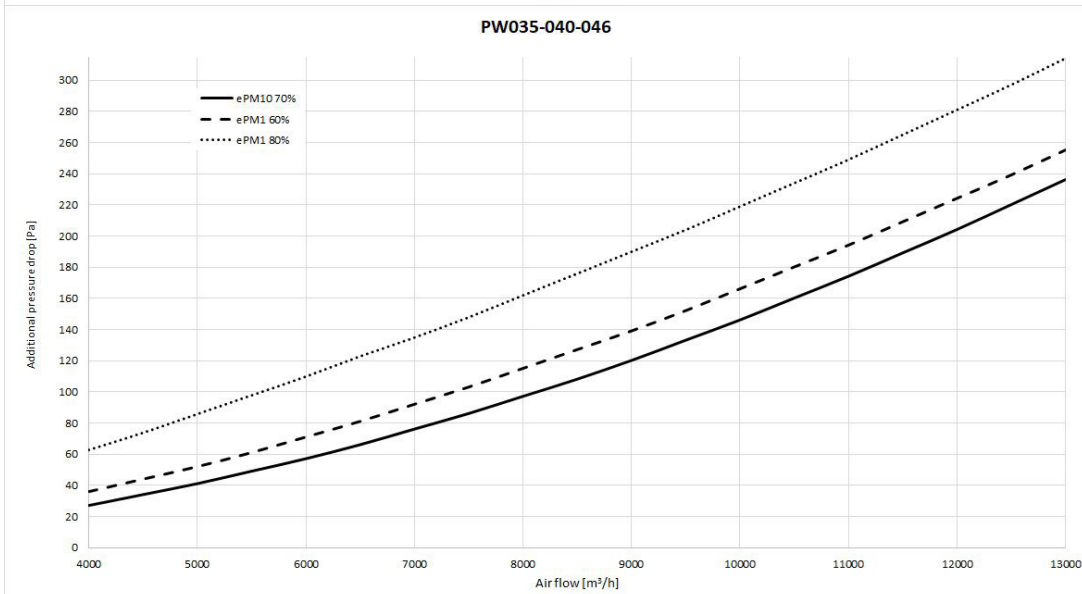
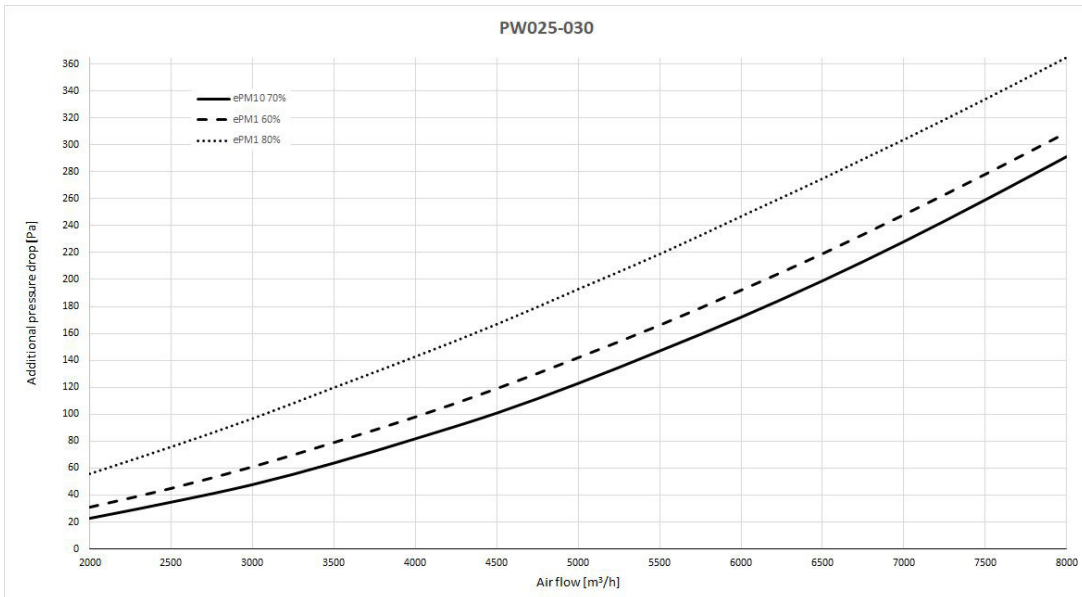

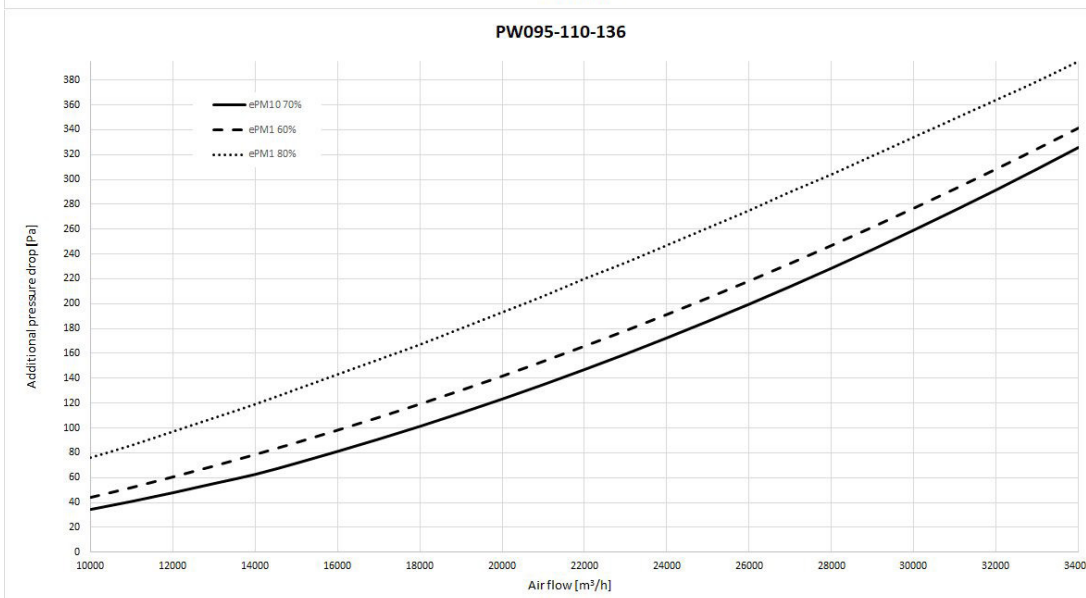
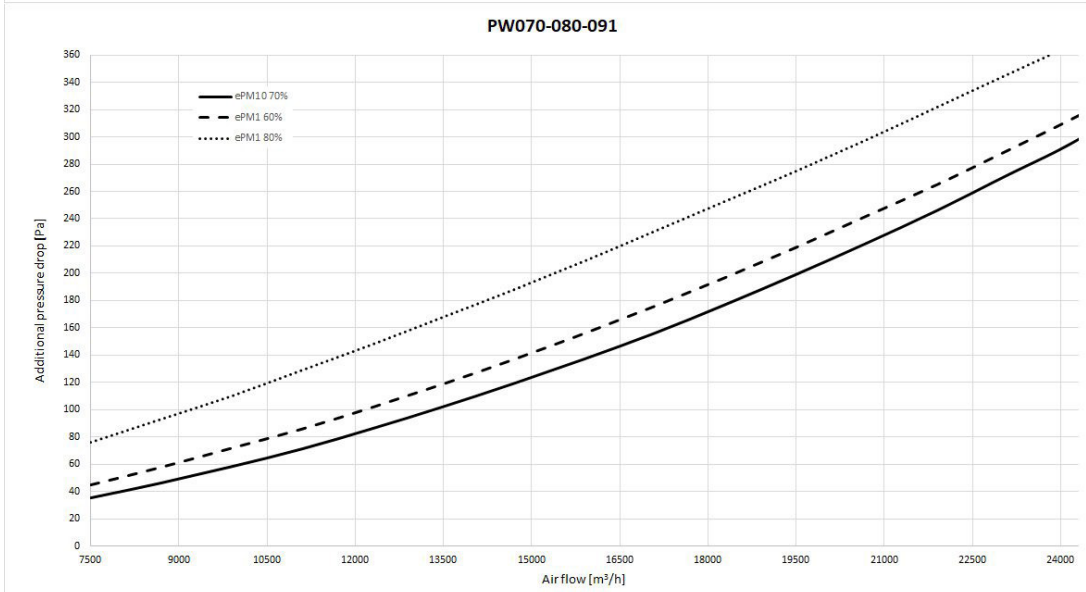
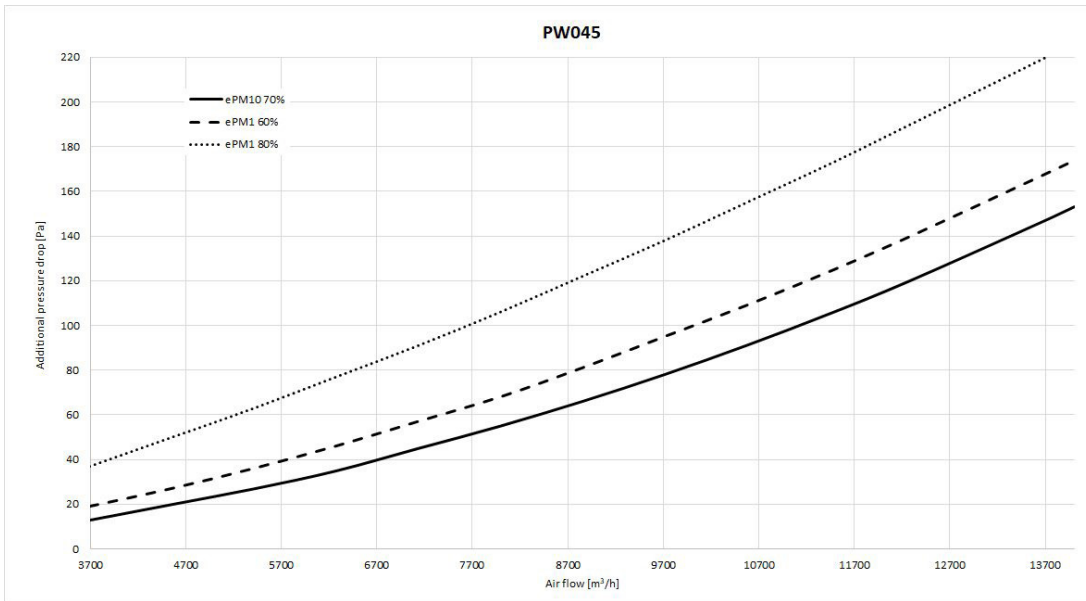

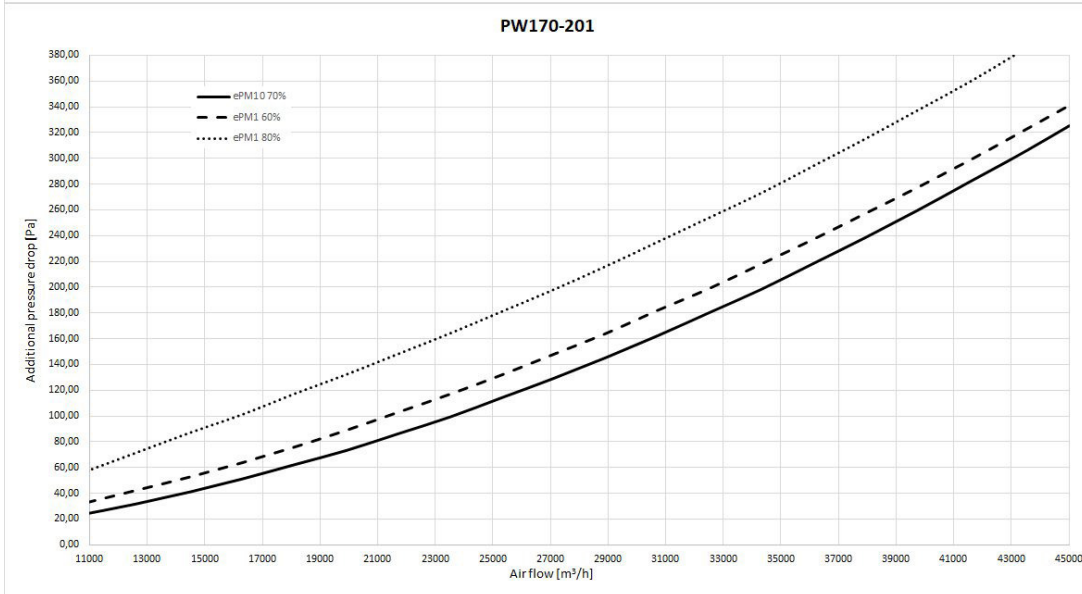
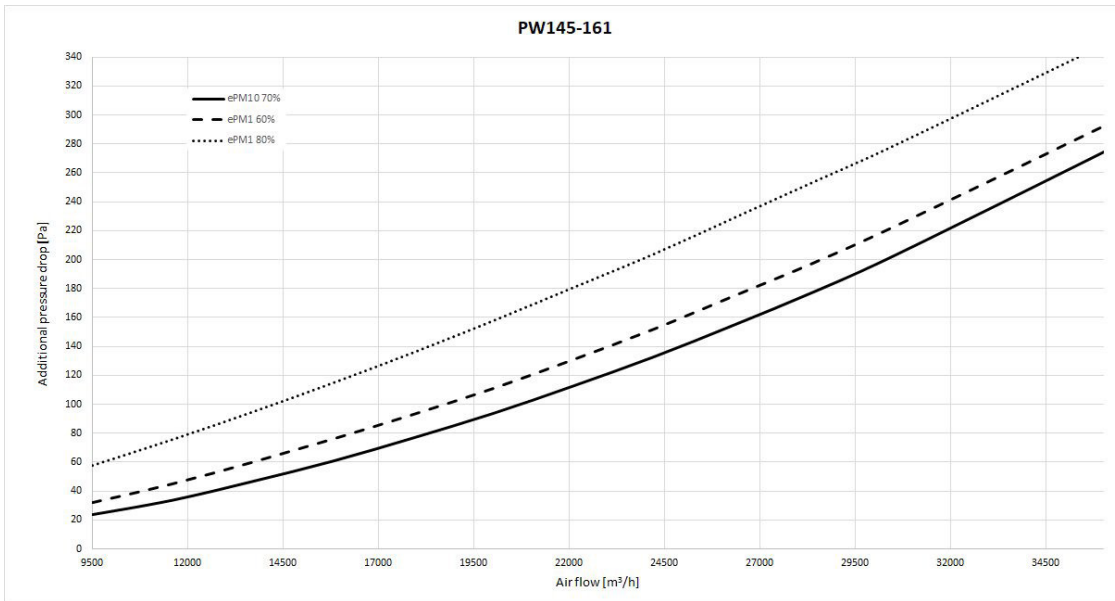

Clogged filter alarm (option)

The unit can be fitted with a filter differential static pressure switch, connected to the microprocessor controller to provide 'Filter Clogged' warning indication. Gauge after and before the filter are installed for measuring the Dp



Filter differential pressure transducer (option)

The unit can be fitted with a filter differential pressure transducer, connected to the microprocessor controller to provide a dynamic 'Filter Status'.

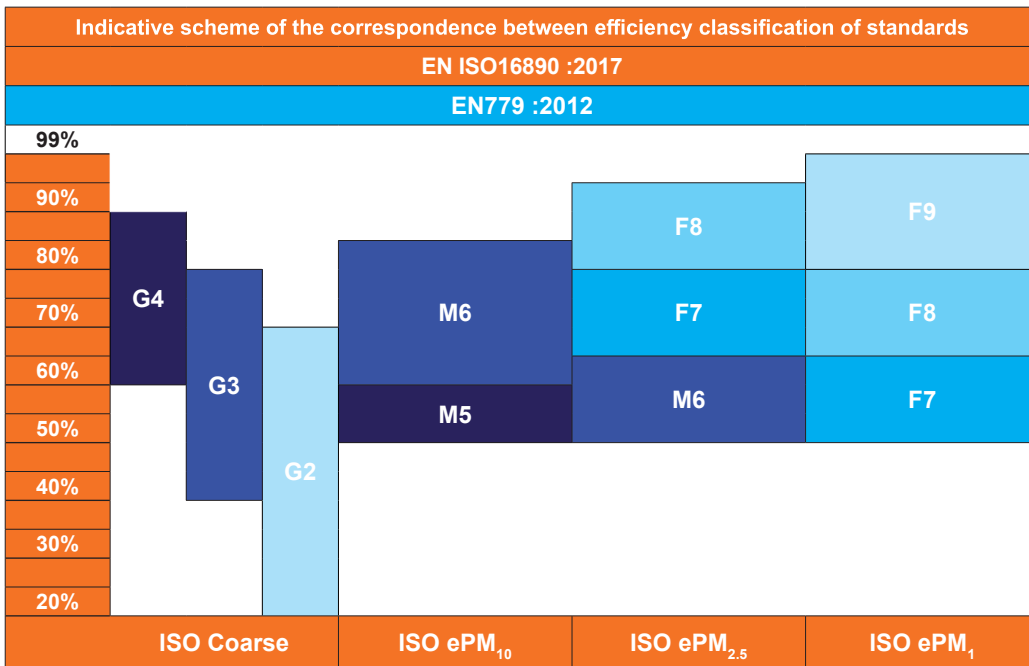

Indicative scheme of the correspondence between efficiency classification of standards

| EN 779:2012 Coarse Filters Average Arrestance (Am) | EN 779:2012 Medium and Fine Filters Average Efficiency (Em) | ASHRAE Standard 52.2 Minimum Efficiency Reporting Value (MERV) |
|---|--|---|
| 50% ≤ Am < 65% G1 | | MERV 1-4 |
| 65% ≤ Am < 80% G2 | | MERV 1-4 |
| 80% ≤ Am < 90% G3 | | MERV 5 |
| 90% ≤ Am G4 | | MERV 6-8 |
| | 40% ≤ Em < 60% M5 | MERV 8-10 |
| | 60% ≤ Em < 80% M6 | MERV 9-13 |
| | 80% ≤ Em < 90% F7 | MERV 13-14 |
| | 90% ≤ Em < 95% F8 | MERV 14-15 |
| | 95% ≤ Em F9 | MERV 16 |

4.4.3 Electrical reheating/heating



The heating resistors are of a rigid design for extended operational life and are normally utilized to maintain room dry-bulb conditions during a system call for dehumidification. Each stage of the heaters is made of finned armored stainless steel AISI 304 to maintain a low surface power density. Ionization effects are eliminated owing to the low heater surface temperature.

Heating control is of the ON-OFF type. The heaters are phase balanced and a safety air high temperature sensor measures the air temperature at the unit outlet and switches off the heater if the air temperature is higher than the alarm threshold, moreover, heaters are provided with a manual reset safety thermostat to disable them in the event of a high temperature.

The heating system also incorporates Miniature Circuit Breaker(s) which protect the heater(s) from short circuits, should the harness be damaged accidentally. Due to the heat load generated by the electrical heaters, these devices should respect a distance of 20 cm around the fan blades circumference.

Table 4.03 - Electrical heaters data

| Unit model | 400 V / 3ph / 50 Hz | | | | 460 V / 3ph / 60 Hz | | | | 380 V / 3ph / 60 Hz | | | |
|------------|-----------------------|--------------------|-------------------|--------------------|-----------------------|--------------------|-------------------|--------------------|-----------------------|--------------------|-------------------|--------------------|
| | Standard Capacity [A] | | High Capacity [A] | | Standard Capacity [A] | | High Capacity [A] | | Standard Capacity [A] | | High Capacity [A] | |
| | FLA [A] | Nominal Power [kW] | FLA [A] | Nominal Power [kW] | FLA [A] | Nominal Power [kW] | FLA [A] | Nominal Power [kW] | FLA [A] | Nominal Power [kW] | FLA [A] | Nominal Power [kW] |
| PW025 | 10.8 | 7.5 | - | - | 9.4 | 7.5 | - | - | 11.4 | 7.5 | - | - |
| PW030 | 10.8 | 7.5 | - | - | 9.4 | 7.5 | - | - | 11.4 | 7.5 | - | - |
| PW035 | 10.8 | 7.5 | - | - | 9.4 | 7.5 | - | - | 11.4 | 7.5 | - | - |
| PW040 | 10.8 | 7.5 | - | - | 9.4 | 7.5 | - | - | 11.4 | 7.5 | - | - |
| PW046 | 10.8 | 7.5 | - | - | 9.4 | 7.5 | - | - | 11.4 | 7.5 | - | - |
| PW045 | 10.8 | 7.5 | - | - | 9.4 | 7.5 | - | - | 11.4 | 7.5 | - | - |
| PW060 | 10.8 | 7.5 | 21.6 | 15.0 | 9.4 | 7.5 | 18.8 | 15.0 | 11.4 | 7.5 | 22.8 | 15.0 |
| PW066 | 10.8 | 7.5 | 21.6 | 15.0 | 9.4 | 7.5 | 18.8 | 15.0 | 11.4 | 7.5 | 22.8 | 15.0 |
| PW070 | 10.8 | 7.5 | 21.6 | 15.0 | 9.4 | 7.5 | 18.8 | 15.0 | 11.4 | 7.5 | 22.8 | 15.0 |
| PW080 | 10.8 | 7.5 | 21.6 | 15.0 | 9.4 | 7.5 | 18.8 | 15.0 | 11.4 | 7.5 | 22.8 | 15.0 |
| PW091 | 10.8 | 7.5 | 21.6 | 15.0 | 9.4 | 7.5 | 18.8 | 15.0 | 11.4 | 7.5 | 22.8 | 15.0 |
| PW095 | 10.8 | 7.5 | 32.5 | 22.5 | 9.4 | 7.5 | 28.2 | 22.5 | 11.4 | 7.5 | 34.2 | 22.5 |
| PW110 | 10.8 | 7.5 | 32.5 | 22.5 | 9.4 | 7.5 | 28.2 | 22.5 | 11.4 | 7.5 | 34.2 | 22.5 |
| PW136 | 10.8 | 7.5 | 32.5 | 22.5 | 9.4 | 7.5 | 28.2 | 22.5 | 11.4 | 7.5 | 34.2 | 22.5 |
| PW145 | 10.8 | 7.5 | 32.5 | 22.5 | 9.4 | 7.5 | 28.2 | 22.5 | 11.4 | 7.5 | 34.2 | 22.5 |
| PW161 | 10.8 | 7.5 | 32.5 | 22.5 | 9.4 | 7.5 | 28.2 | 22.5 | 11.4 | 7.5 | 34.2 | 22.5 |
| PW170 | 10.8 | 7.5 | 32.5 | 22.5 | 9.4 | 7.5 | 28.2 | 22.5 | 11.4 | 7.5 | 34.2 | 22.5 |
| PW201 | 10.8 | 7.5 | 32.5 | 22.5 | 9.4 | 7.5 | 28.2 | 22.5 | 11.4 | 7.5 | 34.2 | 22.5 |

Hot Water reheating/heating (optional)

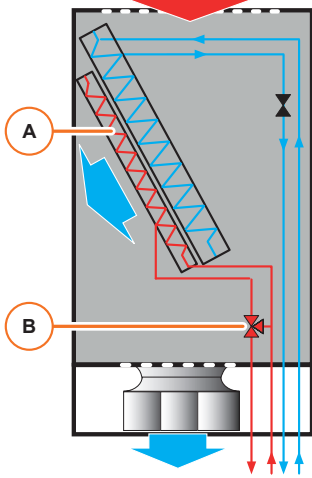

The single hot water heating coil is installed downstream of the cooling coil, with a 3-port on/off control valve, suitable for a maximum working pressure of 8.5 bar. The coil is manufactured from copper tubes, mechanically bonded to aluminum fins, and is pressure tested to 30 bar.

The hot water heating coil is active as first source, the electrical heater is active as second one when the hot water coil is not able to fully satisfy the heating request.

4.4.4 Humidifier (optional)

The unit can keep the humidity of the environment at the requested set point through humidification and dehumidification functions; the dehumidification function is embedded when the humidifier is installed.

Electrode humidifier

The unit is fitted with an electrode boiler humidifier.

The humidifier is completed with a water inlet valve, water outlet pump and a maximum water level sensor. Steam from the cylinder is mixed with the discharge air from the evaporating coil by means of a copper steam distributor.



Technical data

Electrode humidifier technical data

| Main power supply | Setting ⁽¹⁾ | Absorbed current | Power | MAX water cylinder volume | MAX water supply | MAX drained water |
|-------------------------------------|------------------------|------------------|-------|---------------------------|------------------|-------------------|
| [V ± 10%] | [kg/h] | [A] | [kW] | [l] | [l/min] | [l/min] |
| 400 V / 3 ph / 60 Hz | 3,9 - 8 | 8,7 | 6 | 5,5 | 0,6 | 7,0 |
| 460 V / 3 ph / 60 Hz | 3,9 - 8 | 7,5 | 6 | 5,5 | 0,6 | 7,0 |
| 380 V / 3 ph / 60 Hz | 3,9 - 8 | 9,1 | 6 | 5,5 | 0,6 | 7,0 |
| 400 V / 3 ph / 50 Hz ⁽²⁾ | 15 | 16,2 | 11,25 | 9,8 | 1,2 | 7,0 |

(1) The humidifier can be set between the 30 - 100% of the capacity, in steps of 10%. The humidifier mounted in the unit is factory-set to produce about 50% of the maximum value (see the iCOM™ manual);

(2) Only for PW400.

Infrared humidifier

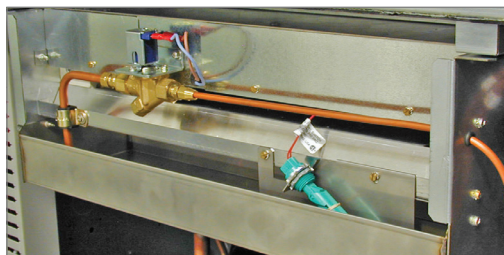

The unit is fitted with an infrared humidifier suitable for use with water of varying degrees of hardness. The humidifier is complete with a water inlet valve, and a maximum water level sensor; the humidifier includes high-intensity quartz lamp on water creating instantaneous moisture using almost any water quality. The cleanable stainless-steel humidifier pan is removable from front of the unit

Technical data

Infrared humidifier technical data

| Size | Main power Supply [V ± 10%] | Pan Material | Capacity [kg/h] | Absorbed Current [A] | Power [kW] |
|-------|-----------------------------|-----------------|-----------------|----------------------|------------|
| Small | 400 V / 3 ph / 50 Hz | Stainless steel | 5,0 | 6,9 | 4,8 |
| | 380 V / 3 ph / 60 Hz | Stainless steel | 5,0 | 7,3 | 4,8 |
| | 460 V / 3 ph / 60 Hz | Stainless steel | 5,0 | 6,0 | 4,8 |
| Big | 400 V / 3 ph / 50 Hz | Stainless steel | 10,0 | 13,9 | 9,6 |
| | 380 V / 3 ph / 60 Hz | Stainless steel | 10,0 | 14,6 | 9,6 |
| | 460 V / 3 ph / 60 Hz | Stainless steel | 10,0 | 12,0 | 9,6 |

Ultrasonic Humidifier



The unit shall be ready for the installation on the bottom part with an ultrasonic humidifier.

The humidifier consists of nebulization modules, valve for the control of the supply water, float switch and a case that houses the fan. Piezoceramic transducers are attached to the bottom of a tank filled with water and produce ultrasonic vibrations that create capillary waves on the water surface, developing a water mist.

Technical data

Ultrasonic humidifier technical data

| Main power Supply [V ± 10%] | Capacity [kg/h] | Transformer [VA] | Power Consumption [W] | Absorbed Current [A] | Number of Transducers |
|-----------------------------|-----------------|------------------|-----------------------|----------------------|-----------------------|
| 400 V / 1 ph / 50 Hz | 0 - 8,0 | 800,0 | 530,0 | 11,0 | 16 |

4.5 Electric System

4.5.1 Electric panel

The electrical panel, located at the front of the unit in a compartment isolated from the airflow, contains the MCB's, contactors, transformers, controller PCB, overload relays etc. Each high voltage system component is provided with an MCB over-current protective device. All high voltage components are touch protected. Once open, the electrical panel can be rotated on the right to allow for an easier installation/maintenance procedure.

Each unit is equipped, on the internal electrical panel, with an ON/OFF switch which allows to turn ON-OFF the unit especially when the unit is without display. Close to the switch a LED provides visual indication of the unit ON/OFF status.

The electrical panel complies with the IEC norm EN60204-1.

Power supply variability

- Check that the maximum unbalance between the phases does not exceed the value given in 6. *Technical Data*.
- Make sure to comply with the following data:
 - Electrical voltage between 0.9 and 1.1 nominal voltage
 - Frequency between 0.99 and 1.01 the nominal frequency
 - Variability of supply voltage less than 2%

See the figure below for variability evaluation.

Example of calculating phase to phase variability

1) The 400 V supply has the following variability:

$$RS = 394 \text{ V}$$

$$ST = 401 \text{ V}$$

$$RT = 402 \text{ V}$$

2) The average voltage is:

$$\frac{394 + 401 + 402}{3} = 399$$

3) The deviation from the average is:

$$399 - 394 = 5 \text{ V}$$

$$401 - 399 = 2 \text{ V}$$

$$402 - 399 = 3 \text{ V}$$

4) The phase-to-phase variability is:

$$\frac{\text{maximum voltage deviation}}{\text{average voltage}} \times 100\% = \frac{5}{399} \times 100\% = 1,253\% \text{ (acceptable)}$$

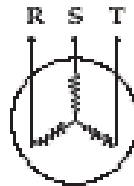

Power supply connection

The units are equipped with electrical devices (power supplies module, control devices,...) that are designed to operate properly with star-connected power (Wye) with earthed neutral (TN or TT system).

If you need three-phase distribution Delta-connected (Δ) or Star-connected power (Wye) without ground or floating ground (IT) please contact Vertiv™ Technical Support.

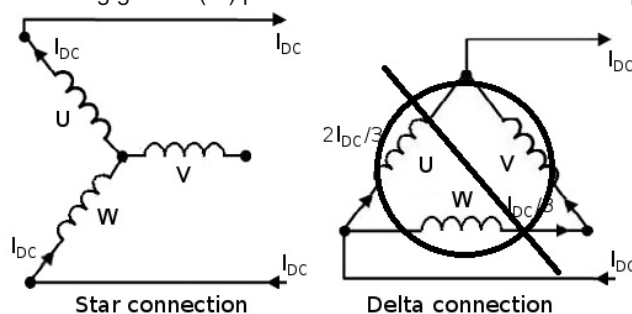

Power supply type Acceptable:

- TT, TN-S, TN-C, TN-C-S systems
- 460 V Wye with solidly grounded neutral (266 V line to ground)
- 380 V Wye with solidly grounded neutral (220 V line to ground)

Unacceptable:

- 380 to 460 V Wye without ground connection or with high-resistance (or impedance) ground (IT).
- 380 to 460 V Δ without ground or with high-resistance (or impedance) ground (IT).
- 380 to 460 V Δ with corner ground or with grounded center-tapped.

4.5.2 Standard or dual power supply

The unit may be delivered with standard power supply or optional dual power supply in order to have the units up and running if the main power supply fails.

The following table explains the main options.

Make reference to the *Electric Diagrams* for details about your unit power supply system.

See *User Manual* for the power supply relevant data and limits (voltage, frequency, ...).

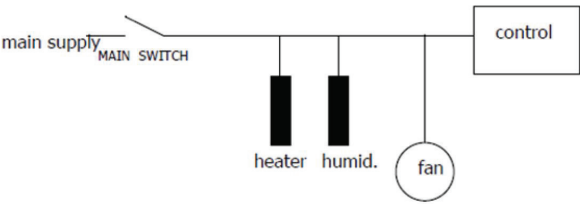
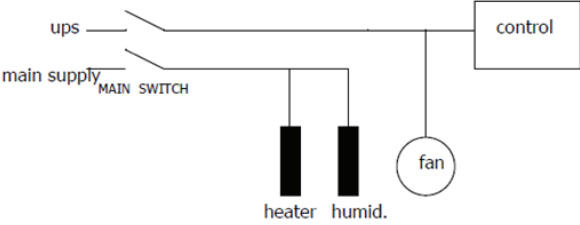
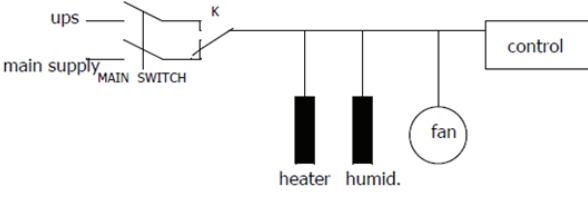
| Option | Description | What happens in case of power failure | What happens when power is restored |
|--|--|--|---|
| <p>Standard power</p>  | <p>Single supply line</p> | <p>The unit is fed by main line, in case of power failure unit switch off.</p> | <p>Once power is restored the unit waits control reboots (roughly 60 seconds) and after start again to operate.</p> |
| <p>Dual power supply "parallel"</p>  | <p>Double power supply to the same disconnecting switch</p> | <p>The unit is fed by two separate power supplies, main line and UPS/Genset. In case of power failure only UPS/Genset is available and unit grant cooling</p> | <p>Once main power restored heating and humidification are available and they can be enable.</p> |
| <p>Dual power supply alternate</p>  | <p>Double power supply to the ATS electric panel, which is connected to the main electric panel. Each power supply can supply completely the unit.</p> | <p>The unit is fed by two separate power supplies: each power supply can completely feed the unit. In case of main line failure ATS switches to the second power supply. This allows to have a complete power supply redundancy and therefore to have full cooling redundancy. Switching time at nominal current excluding loss of supply sensing time and excluding any delay timers applicable is at least 1.2 s -1.5 s.</p> | <p>Once main power restored ATS switch back to the main line.</p> |

| Option | Description | What happens in case of power failure | What happens when power is restored |
|---|--|--|---|
| <p>Dual power supply alternate with Ultracap for Control</p> | <p>Double power supply to the ATS electric panel, which is connected to the main electric panel. Each power supply can supply completely the unit. Control board is powered through an ultracap.</p> | <p>Unit is fitted with Dual Power Supply Alternate Version. The unit is fed by two separate power supplies: each power supply can completely feed the unit. In case of main line failure ATS switches to the second power supply. This allows to have a complete power supply redundancy and therefore to have full cooling redundancy during emergency mode. Switching time at nominal current excluding loss of supply sensing time and excluding any delay timers applicable is at least 1,2-1,5 s. The ultracapacitor when completely charged, is capable of maintaining alive the CPU, the BMS card and the passive sensors for at least 1 minute (only the optional small semi-graphic display can be kept active by the ultracapacitor), the full charging time for the ultracapacitor is 5 minutes. The remote sensors are frozen during the power OFF.</p> | <p>Once main power restored ATS switch back to the main line.</p> |

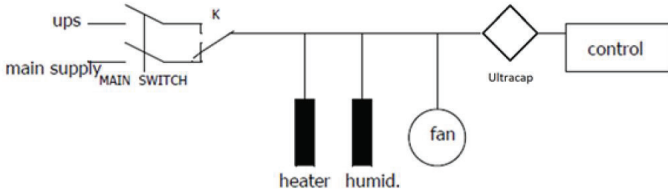

ATS Positioning Monitoring – Option

Unit can display and share with BMS system (if monitoring card is present) which line is powering the unit, and thus also the position of the Automatic Transfer Switch

5.5.2 EMC Emission

The unit satisfies the requirements for EMC regarding electro-magnetic emissions IEC61000-6-2.

Industrial

The unit satisfies the requirements of IEC61000-6-4.

This choice aims to comply with requirements of compatibility of light industrial environments as regards the emission of disturbances, resisting to external disturbances without having any functionality compromised. In terms of the norm references for emissions: the conducted voltage disturbance must be lower than 73 dBuV and radiated voltage disturbance lower than 50 dBuV (@ 3 m).

Residential (optional)

The unit satisfies requirements of IEC61000-6-3.

This is the preferred choice when the unit operates in an environment where also residential or small office devices are connected to the same power supply, and these are more sensitive to disturbance emitted by other devices, so a higher severity is needed when the unit emissions are measured.

In terms of the norm references for emissions: the conducted voltage disturbance must be lower than 66 dBuV and radiated voltage disturbance lower than 40 dBuV (@ 3 m).

4.6 Control System

4.6.1 Control system and display

The Control System is microprocessor based.

Terminals are provided for remote start/stop control plus Volt-free 'Common Alarm', 'Common Warning'. Full list of microprocessor features includes:

| | |
|--------------------------------|---|
| Microprocessor features | <p>Single Circuit units</p> <ul style="list-style-type: none"> • Up to 7 configurable digital inputs (for instance, condensate pump alarm, heater alarm, fire alarm, water alarm, NO power, etc...) • 1 digital input for remote ON/OFF • 2 digital outputs to report general warning and general alarm • 1 RS485 Master Fieldbus line • 1 RS485 Master/Slave Fieldbus line • 1 Ethernet port <p>Double Circuit units</p> <ul style="list-style-type: none"> • Up to 8 configurable digital inputs (for instance, condensate pump alarm, heater alarm, fire alarm, water alarm, NO power, etc...) • 1 digital input for remote ON/OFF • 2 digital outputs to report general warning and general alarm • 2 RS485 Master/Slave Fieldbus line • 1 Ethernet port |
| Programming devices | <p>The microprocessor can be programmed, in alternative, through:</p> <ul style="list-style-type: none"> • a 7", high definition (resolution 800 x 480 pixel) color capacitive touchscreen display that shall be mounted in an ergonomic, aesthetically pleasing housing. • a 10", high definition (resolution 1280 x 800 pixel) widescreen, multitouch projected capacitive touchscreen display that shall be mounted in an ergonomic, aesthetically pleasing housing. • For units without display, a Virtual Display can be replicated through a web browser, all the functionalities of the standard display are available, either remotely or connecting a laptop on the Ethernet port directly to the frontal door. • Small display – Option. Small display is a semi-graphic LCD monochromatic terminal with 132x64 pixel resolution, LED backlighted. It provides buttons to navigate through the screen |
| Menu-driven control | <p>The application shall be menu-driven.</p> <p>User Profile: The application shall display menus for basic setpoints, temperature and humidity alarms (limits), run hours for each device, timers bands, event log, unit overview and system overview.</p> <p>Service Profile: The application shall display menus and a password shall be required to make system changes.</p> |
| Warnings / alarms | <p>More than 240 types of warnings / alarms / messages are displayed including:</p> <ul style="list-style-type: none"> • High temperature (return/remote/supply) • Low temperature (return/remote/supply) • High relative humidity (return/remote) • Low relative humidity (return/remote) • Fan failure • Electrical heater high temperature • Sensor failure <p>Unit can storage up to 100 events in a memory. Each unit shall have one factory mounted return temperature and humidity</p> |

| | |
|--|---|
| Sensors | The control as standard allows to manage: <ul style="list-style-type: none"> • A return temperature and humidity sensor • A supply temperature sensor • Up to 10 active remote temperature and humidity sensors • Up to 3 read-only temperature and humidity reference sensors |
| Supply temperature sensor - Optional | NTC sensor can be provided for acting supply control logics. |
| Remote Temperature sensor - Accessory | The remote temperature sensors can be Active or Read-only. |
| Active remote temperature and humidity sensors | Unit shall permit to select the minimum, maximum or average values read by the multiple remote sensors, in order to have the choose best control strategy. A remote sensor can be even select for succeeding redundant sensors. |
| Read-only room temperature and humidity reference sensors | The remote sensors are used for reading temperature and humidity in specific area of the room without any impact on the unit control logic. |
| PID settings | Unit shall allow controlling the cooling capacity and fan speed from multiple different sensor selections. The control shall have auto adaptive algorithms known as PIDs. The user shall finally act on the Set Points of the main PIDs (like Air Temperature and Humidity Control). Specific PIDs settings shall be changeable by the Service Personnel during commissioning if this is necessary; cooling capacity and fan speed PIDs can be decoupled if needed. |
| Temperature control mode | Temperature control mode defines from which sensor cooling capacity will be driven. Three options are available: <ul style="list-style-type: none"> • Return • Supply • Remote |
| Fan speed control mode | Fan speed control mode defines how airflow will be controlled. Five options are available: <ul style="list-style-type: none"> • Return Sensor • Remote Sensor • Delta T between Return temperature and supply temperature • Static Pressure • Return CW priority • Fixed Speed |
| Humidity control mode | Humidity control mode defines from which sensor humidification and dehumidification will be driven. Two options are available: <ul style="list-style-type: none"> • Return Sensor • Remote Sensor |
| Humidity Control Type | Humidity Control Type available are: <ul style="list-style-type: none"> • Relative • Relative Compensated • Absolute • Dew Point <p>In case of control sensor failure, the unit automatically adapts to keep cooling/airflow continuity.</p> |

4.6.2 Teamwork

An U2U (unit to unit) communication between multiple units via Ethernet network (up to 32 units) allows for advanced control functionality: teamwork modes, sharing sensor data, standby rotation, lead-lag, cascade operation, auto restart delay and rotating master function; without the need of a dedicated sequencing panel. Four 'teamwork' mode can be adopted.

| | |
|--------------------|--|
| No Teamwork | The units work independently on the cooling control. Sensor values and setpoints are not shared. |
|--------------------|--|

The control drives cooling, heating, ventilation, humidification and dehumidification based on the local requests. Standby function and unit rotation are possible.

Teamwork mode 1 (Parallel) The control uses the system PI's for driving cooling, heating, ventilation, humidification and dehumidification. In these Teamwork mode, all relevant control parameters are shared; if a value is changed in any of the units, all other units will follow with the same changed setting.

Teamwork Mode 2 (Independent) The control drives cooling, heating, ventilation, humidification and dehumidification based on local requests, while avoiding operational conflict with the other units in the network. For example: If one unit is on cooling, no other unit may start heating. If one unit is on dehumidification, no other unit may start humidification.
In this Teamwork mode, all relevant control parameters are shared; if a value is changed in any of the units, all other units will follow with the same changed setting.

Teamwork Mode 3 (Smart Aisle™) The control uses the system PI's for driving ventilation, humidification and dehumidification. Local request is used for driving cooling and heating. Note: this teamwork mode can be set only if the smart aisle option has been enabled and remote sensors are ordered. The unit should have temperature sensor as controlling sensor.
A Master controls duty, standby and rotation, calculates System Values and sends it to the other units in the system. The Master holds the selected number of units and starts/stops the units in order to have the requested number of units working.

Standby Rotation Each unit in the group needs to get a unique communication number. The rotation index number defines the order of which unit will be the next one to be activated.

Lead-lag Units, before to go in standby mode, shall continue operation for the time set in "Overlap Timer".

Auto Restart Delay Avoid a simultaneously re-start of multiple units (no matter if teamwork is selected or not). Each unit has a delay time between Power **ON** and starting of the fans after a power cycle.

Cascade Usually Standby Units will start in case of an alarm of one of the Duty Units. Cascaded units will also start in order to help the Duty Unit base on the cooling request (Teamwork 1) or for Airflow request (Teamwork 3) In this way system case of an alarm/failure.

Rotating Master As part of the robust architecture of the control, when the Master gets disconnected from the network, another unit will automatically change to be the Master. All system values are available for all connected units.
When the Master gets disconnected from the network, another unit (the unit with the lowest U2U_ID in the remaining network) will automatically change to be the Master. This feature avoids system reset when the Master disappears or when it comes back available in the system.

4.6.3 Smart Aisle™ (optional)

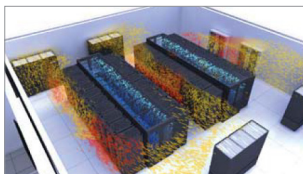

The unit should have the capability to modulate airflow according to the airflow taken by the servers, using remote temperature sensor as controlling sensor, installed in the top part of the aisle which communicate between the aisle through a calibrated hole. This guarantee to maximize the system efficiency providing to the server only airflow needed. The valve shall be modulated according to the unit air supply temperature in order to optimize server inlet temperature.



The system done by multiple units shall work with efficient cascade way, trying to maximize energy efficiency always working where EC Fans are more effective.

The unit is equipped by default with a special switch that allows to change easily three different working mode:

- automatic control of airflow and cooling
- unit forced to OFF mode
- airflow and cooling forced to 100%

4.6.4 Cooling Override (optional)

During control reboot due to a power outage or in case of control failure, the cooling continuity is guaranteed without any capacitors last position or driving it to pre-set point. Once the communication has been re-established, the valve and fans control are released to normal operation. In case of dampers, this feature disables fan actions.

4.6.5 Super Saver (optional)

The Supersaver function enables network between indoor and outdoor units in order to maximize chiller freecooling operation. Whenever possible the system will automatically raise water temperatures as thermal loads fall, aligning cooling capacity with never impact the unit supply air temperature threshold, in order to guarantee the right temperature in front of the technical equipments. This feature is available with all the chillers which implement this feature and can communicate with the indoor units.

4.6.6 Monitoring (optional)

The unit features website that can be accessed via HTTP using a common browser.

The unit shall also include input for report ON-OFF and volt-free contacts for simple remote monitoring of alarms.

If the monitoring card is present the unit can communicate with Building Management Systems and Network Management.

Systems supporting third party protocols: Modbus TCP/IP RTU, BACnet IP v1.14, SNMP v2c, v3 and HTTP. More than 600 different parameters/events are available to BMS.

5. Technical Data

Content of this chapter

| | | | |
|----------------------------|----|---|----|
| 5.1 Performances..... | 31 | 5.4 Condensate Pump (optional)..... | 49 |
| 5.2 Fan..... | 35 | 5.5 Water Temperature Sensors & Flow Meter (optional).... | 49 |
| 5.3 Water Connections..... | 48 | 5.6 Energy Meter (optional)..... | 49 |

5.1 Performances

Chilled water perimeter cooling units' performances are linked to working conditions: return air and water temperatures. Each unit model can provide a wide range of capacity depending on the environment it's applied in, with a hoc coil to best suit the new data center market trends.

Below a description of the most common conditions currently used in data center applications, which are in continues evolution and they differentiated according to customers' needs.

Liebert® PCW is an extremely flexible unit able to adapt to different site needs, Vertiv™ sales force can provide the unit performances at different working conditions through a dedicated selecting tool.

Legacy

This kind of system generally includes a freecooling chiller and works with water regimes from 10°C to 15°C. Server containment is not so common and the return air temperature to the **Liebert® PCW** is around 26°C. This system gives the possibility to work in freecooling mode thanks to low external temperatures during the entire cold season. The inlet water temperature around 10°C minimizes the dehumidification effect compared to a comfort application, thus reducing energy wastage.

Smart

This kind of system generally includes freecooling/adiabatic chiller and works with water regimes from 18°C to 26°C, they are always combined with a server containment. It's a system optimized to offer the highest energy efficiency, thanks to the closure of the aisle the return air to the **Liebert® PCW** can be significantly high and therefore higher water temperatures are allowed. This maximizes the freecooling period and makes this system suitable for all climates; even on hot countries.

Eco

This kind of system is generally made of a standard chiller without freecooling and works with water regimes from 8°C to 15°C. This system is often applied when the same chilled water system is used both for cooling the data center as well as for other applications. In case of an existing system, only the perimeter chilled water units are replaced and no other modifications to the chilled water plant is required. Thanks to server containment the return air to the **Liebert® PCW** can be significantly high. The low water temperatures increase the risk of dehumidification and for data center applications the dehumidification is not an advantage, in fact the only heat load provided by the server is sensible heat load. **Liebert® PCW** is thus optimized to provide the highest net sensible capacity even at low water temperatures.

Working point

Rated performances are stated in **PW** Product document for the working points specified in the following table:

| Coil type | ESP (*) [Pa] | Return Air temperature [°C] | RH [%] | Inlet Water temperature [°C] | Outlet Water temperature [°C] |
|------------------|--------------|-----------------------------|--------|------------------------------|-------------------------------|
| Legacy coil | 20 | 26 | 40 | 10 | 15 |
| Smart coil | 20 | 35 | 30 | 18 | 26 |
| Eco coil | 20 | 30 | 30 | 8 | 15 |
| Dual source coil | 20 | 24 | 50 | 7 | 12 |

(*) External Static Pressure

NOTE: For performance in specific working point, please use selection software.

| | | PW025 | PW030 | PW035 | PW040 | PW046 | PW045 | PW060 | PW066 | PW070 | |
|---|---------------------------------|-------|-------|--------|---------|---------|---------|---------|---------|---------|---------|
| Air conditions 26°C/40% RH, water conditions 10/15°C, fan modulation 80% - LEGACY COIL | | | | | | | | | | | |
| Downflow Up | "Nominal air flow" | m³/h | 7493 | 7348.6 | 10992.2 | 10819.6 | 11524.1 | 11927.6 | 20510.1 | 21615.5 | 21782.3 |
| | SHR | --- | 1 | 1 | 1 | 1 | 1 | 1 | 1 | 1 | 1 |
| | "Net sensible cooling capacity" | kW | 26.8 | 29.1 | 39.5 | 44.1 | 45.2 | 47.8 | 72.1 | 83.5 | 79.3 |
| | "Unit power input" | kW | 1.31 | 1.27 | 1.67 | 1.69 | 1.6 | 1.53 | 3.47 | 3.37 | 3.35 |
| | Water flow | l/s | 1.34 | 1.45 | 1.97 | 2.19 | 2.23 | 2.35 | 3.61 | 4.15 | 3.95 |
| | Water pressure drop | kPa | 77 | 74 | 51 | 90 | 52 | 46 | 100 | 99 | 75 |

| | | PW080 | PW091 | PW095 | PW110 | PW136 | PW145 | PW161 | PW170 | PW201 | |
|---|---------------------------------|-------|-------|---------|---------|---------|-------|---------|---------|---------|-------|
| Air conditions 26°C/40% RH, water conditions 10/15°C, fan modulation 80% - LEGACY COIL | | | | | | | | | | | |
| Downflow Up | "Nominal air flow" | m³/h | 21412 | 22316.9 | 31336.6 | 30674.9 | 32263 | 31948.5 | 33349.1 | 40185.2 | 41947 |
| | SHR | --- | 1 | 1 | 1 | 1 | 1 | 1 | 1 | 1 | 1 |
| | "Net sensible cooling capacity" | kW | 85.5 | 96.9 | 111.1 | 119.8 | 135.8 | 137.2 | 151 | 168.4 | 188.1 |
| | "Unit power input" | kW | 3.39 | 3.27 | 5.16 | 5.22 | 5.04 | 5.07 | 4.92 | 6.99 | 6.83 |
| | Water flow | l/s | 4.24 | 4.79 | 5.55 | 5.97 | 6.73 | 6.8 | 7.44 | 8.38 | 9.31 |
| | Water pressure drop | kPa | 56 | 94 | 118 | 85 | 89 | 85 | 78 | 96 | 66 |

| | | PW025 | PW030 | PW035 | PW040 | PW046 | PW045 | PW060 | PW066 | PW070 | |
|---|---------------------------------|-------|-------|--------|---------|---------|---------|---------|---------|---------|---------|
| Air conditions 26°C/40% RH, water conditions 10/15°C, fan modulation 80% - LEGACY COIL | | | | | | | | | | | |
| Upflow | "Nominal air flow" | m³/h | 7493 | 7348.6 | 10992.2 | 10819.6 | 11524.1 | 11927.6 | 20510.1 | 21615.5 | 21782.3 |
| | SHR | --- | 1 | 1 | 1 | 1 | 1 | 1 | 1 | 1 | 1 |
| | "Net sensible cooling capacity" | kW | 26.4 | 28.7 | 39.1 | 43.7 | 45.1 | 47.5 | 71 | 83.2 | 78.4 |
| | "Unit power input" | kW | 1.7 | 1.7 | 2.11 | 2.12 | 1.73 | 1.81 | 4.57 | 3.71 | 4.23 |
| | Water flow | l/s | 1.34 | 1.45 | 1.97 | 2.19 | 2.23 | 2.35 | 3.61 | 4.15 | 3.95 |
| | Water pressure drop | kPa | 77 | 74 | 51 | 90 | 52 | 46 | 100 | 99 | 75 |

| | | PW080 | PW091 | PW095 | PW110 | |
|---|---------------------------------|-------|-------|---------|---------|---------|
| Air conditions 26°C/40% RH, water conditions 10/15°C, fan modulation 80% - LEGACY COIL | | | | | | |
| Upflow | "Nominal air flow" | m³/h | 21412 | 22316.9 | 31336.6 | 30674.9 |
| | SHR | --- | 1 | 1 | 1 | 1 |
| | "Net sensible cooling capacity" | kW | 84.7 | 96.7 | 109.8 | 118.5 |
| | "Unit power input" | kW | 4.25 | 3.53 | 6.48 | 6.51 |
| | Water flow | l/s | 4.24 | 4.79 | 5.55 | 5.97 |
| | Water pressure drop | kPa | 56 | 94 | 118 | 85 |

| | | PW030 | PW040 | PW046 | PW060 | PW066 | |
|--|---------------------------------|-------|--------|---------|---------|---------|---------|
| Air conditions 35°C/30% RH, water conditions 18/26°C, fan modulation 80% SMART COIL | | | | | | | |
| Downflow Up | "Nominal air flow" | m³/h | 7208.8 | 10653.4 | 11420.3 | 19654.8 | 21615.5 |
| | SHR | --- | 1 | 1 | 1 | 1 | 1 |
| | "Net sensible cooling capacity" | kW | 30.4 | 46 | 49.1 | 82.5 | 89.3 |
| | "Unit power input" | kW | 1.28 | 1.71 | 1.61 | 3.55 | 3.39 |
| | Water flow | l/s | 0.95 | 1.43 | 1.52 | 2.58 | 2.78 |
| | Water pressure drop | kPa | 61 | 80 | 66 | 116 | 102 |

| | | PW080 | PW091 | PW110 | PW136 | PW145 | PW161 | PW170 | PW201 | PW400 | |
|--|---------------------------------|-------|---------|---------|---------|---------|---------|---------|---------|-------|-------|
| Air conditions 35°C/30% RH, water conditions 18/26°C, fan modulation 80% SMART COIL | | | | | | | | | | | |
| Downflow Up | "Nominal air flow" | m³/h | 21056.1 | 22107.1 | 30042.9 | 31884.5 | 31948.5 | 33349.1 | 40185.2 | 41947 | 77518 |
| | SHR | --- | 1 | 1 | 1 | 1 | 1 | 1 | 1 | 1 | 1 |
| | "Net sensible cooling capacity" | kW | 90.1 | 101.2 | 125.4 | 142.6 | 136.4 | 151.9 | 167.9 | 187.7 | 372 |
| | "Unit power input" | kW | 3.43 | 3.31 | 5.28 | 5.1 | 5.07 | 4.92 | 6.99 | 5.83 | 11,7 |
| | Water flow | l/s | 2.8 | 3.13 | 3.91 | 4.43 | 4.24 | 4.7 | 5.24 | 5.83 | 11,12 |
| | Water pressure drop | kPa | 72 | 94 | 84 | 98 | 74 | 77 | 83 | 68 | 65 |

| | | PW030 | PW040 | PW046 | PW060 | PW066 | PW080 | PW091 | PW110 | PW070 | |
|--|---------------------------------|-------|--------|---------|---------|---------|---------|---------|---------|---------|---------|
| Air conditions 35°C/30% RH, water conditions 18/26°C, fan modulation 80% SMART COIL | | | | | | | | | | | |
| Upflow | "Nominal air flow" | m³/h | 7208.8 | 10653.4 | 11420.3 | 19654.8 | 21352.2 | 21056.1 | 22107.1 | 30042.9 | 21782.3 |
| | SHR | --- | 1 | 1 | 1 | 1 | 1 | 1 | 1 | 1 | 1 |
| | "Net sensible cooling capacity" | kW | 30 | 45.6 | 49 | 81.4 | 89 | 89.2 | 101 | 124.2 | 78.4 |
| | "Unit power input" | kW | 1.71 | 2.13 | 1.74 | 4.47 | 3.75 | 4.27 | 3.55 | 6.54 | 4.23 |
| | Water flow | l/s | 0.95 | 1.43 | 1.52 | 2.58 | 2.78 | 2.8 | 3.13 | 3.91 | 3.95 |
| | Water pressure drop | kPa | 61 | 80 | 66 | 116 | 102 | 72 | 94 | 84 | 75 |

| | | PW025 | PW035 | PW045 | PW060 | PW070 | PW095 | |
|---|---------------------------------|-------|--------|---------|---------|---------|---------|---------|
| Air conditions 30°C/30% RH, water conditions 8/15°C, fan modulation 80% ECO COIL | | | | | | | | |
| Downflow Up | "Nominal air flow" | m³/h | 7764.5 | 11320.6 | 12115.9 | 21352.5 | 22489.7 | 32612.8 |
| | SHR | --- | 1 | 1 | 1 | 1 | 1 | 1 |
| | "Net sensible cooling capacity" | kW | 26.1 | 39.8 | 48.2 | 70.4 | 78.6 | 108.9 |
| | "Unit power input" | kW | 1.27 | 1.63 | 1.5 | 3.39 | 3.25 | 5.01 |
| | Water flow | l/s | 0.93 | 1.41 | 1.69 | 2.52 | 2.79 | 3.88 |
| | Water pressure drop | kPa | 43 | 52 | 32 | 80 | 65 | 83 |

| | | PW025 | PW035 | PW045 | PW060 | PW070 | PW095 | |
|---|---------------------------------|-------|--------|---------|---------|---------|---------|---------|
| Air conditions 30°C/30% RH, water conditions 8/15°C, fan modulation 80% ECO COIL | | | | | | | | |
| Upflow | "Nominal air flow" | m³/h | 7764.5 | 11320.6 | 12115.9 | 21352.5 | 22489.7 | 32612.8 |
| | SHR | --- | 1 | 1 | 1 | 1 | 1 | 1 |
| | "Net sensible cooling capacity" | kW | 25.7 | 39.3 | 47.9 | 69.3 | 77.6 | 107.5 |
| | "Unit power input" | kW | 1.69 | 2.09 | 1.79 | 4.55 | 4.19 | 6.42 |
| | Water flow | l/s | 0.93 | 1.41 | 1.69 | 2.52 | 2.79 | 3.88 |
| | Water pressure drop | kPa | 43 | 52 | 32 | 80 | 65 | 83 |

| | | PW040 | PW046 | PW060 | PW066 | PW080 | PW091 | |
|---|---------------------------------|-------|---------|---------|---------|---------|---------|-------|
| Air conditions 26°C/40% RH, water conditions 10/15°C, fan modulation 80% DUAL COIL | | | | | | | | |
| Downflow Up | "Nominal air flow" | m³/h | 10265.3 | 11081.5 | 19012.7 | 20702.3 | 20621.2 | 21852 |
| | SHR | --- | 31.4 | 36.8 | 56.1 | 66.9 | 62.9 | 73.5 |
| | "Net sensible cooling capacity" | kW | 1.75 | 1.66 | 3.59 | 3.47 | 3.47 | 3.33 |
| | "Unit power input" | kW | | 1 | | 1 | 1 | 1 |
| | Water flow | l/s | 1.5 | 1.76 | 2.68 | 3.2 | 3 | 3.51 |
| | Water pressure drop | kPa | 85 | 62 | 92 | 83 | 72 | 72 |

| | | PW110 | PW136 | PW145 | PW161 | PW170 | PW201 | |
|---|---------------------------------|-------|---------|---------|---------|---------|---------|---------|
| Air conditions 26°C/40% RH, water conditions 10/15°C, fan modulation 80% DUAL COIL | | | | | | | | |
| Downflow Up | "Nominal air flow" | m³/h | 29328.6 | 31884.2 | 31410.9 | 33038.4 | 39504.9 | 41556.8 |
| | SHR | --- | 87.1 | 103.3 | 95.7 | 110.9 | 117.9 | 136.3 |
| | "Net sensible cooling capacity" | kW | 5.31 | 5.1 | 5.13 | 4.95 | 7.07 | 6.87 |
| | "Unit power input" | kW | 1 | 1 | 1 | 1 | 1 | 1 |
| | Water flow | l/s | 4.16 | 4.94 | 4.58 | 5.3 | 5.63 | 6.51 |
| | Water pressure drop | kPa | 85 | 71 | 67 | 61 | 84 | 73 |

5.2 Fan

The graphics in this chapter shows the fan characteristics for High Efficiency EC fans:

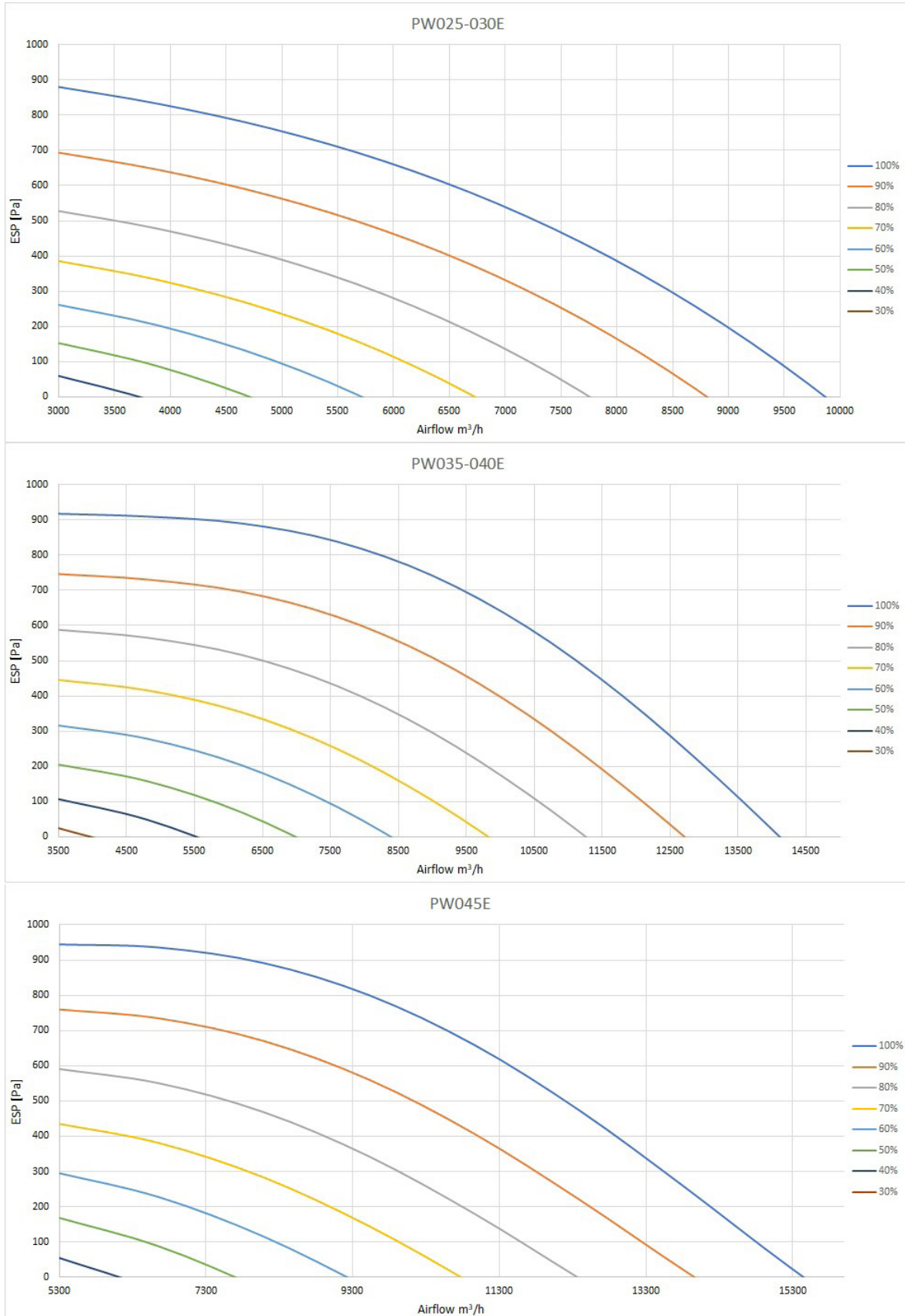

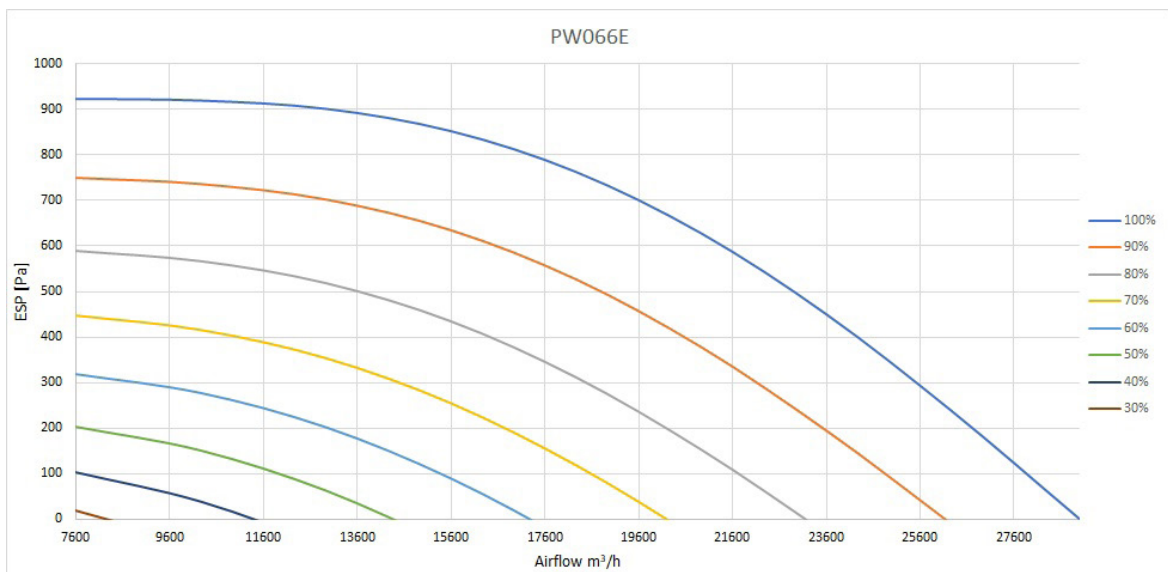
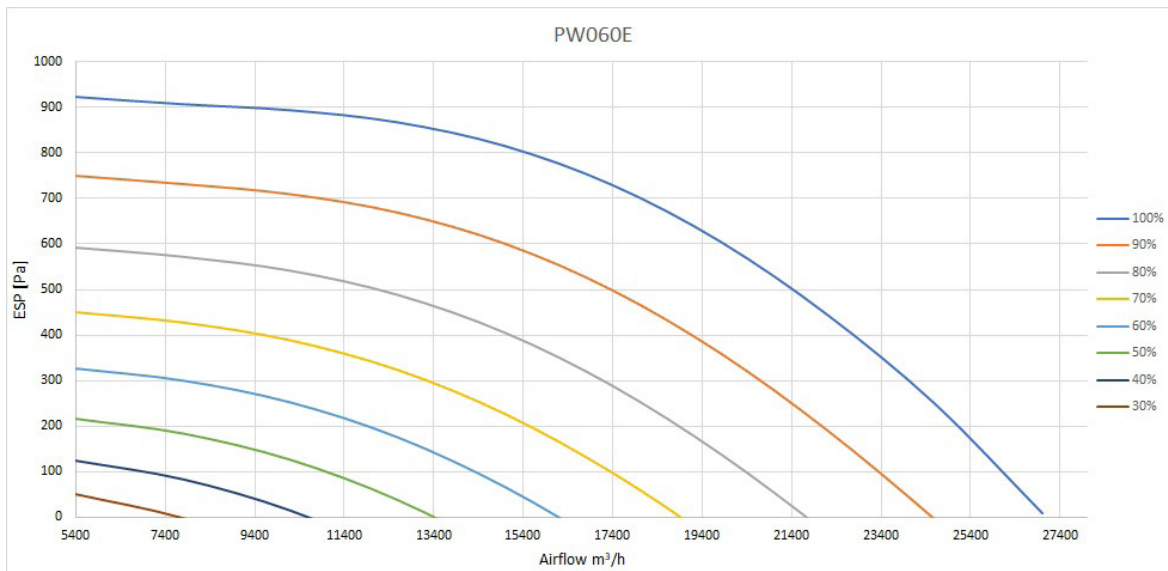
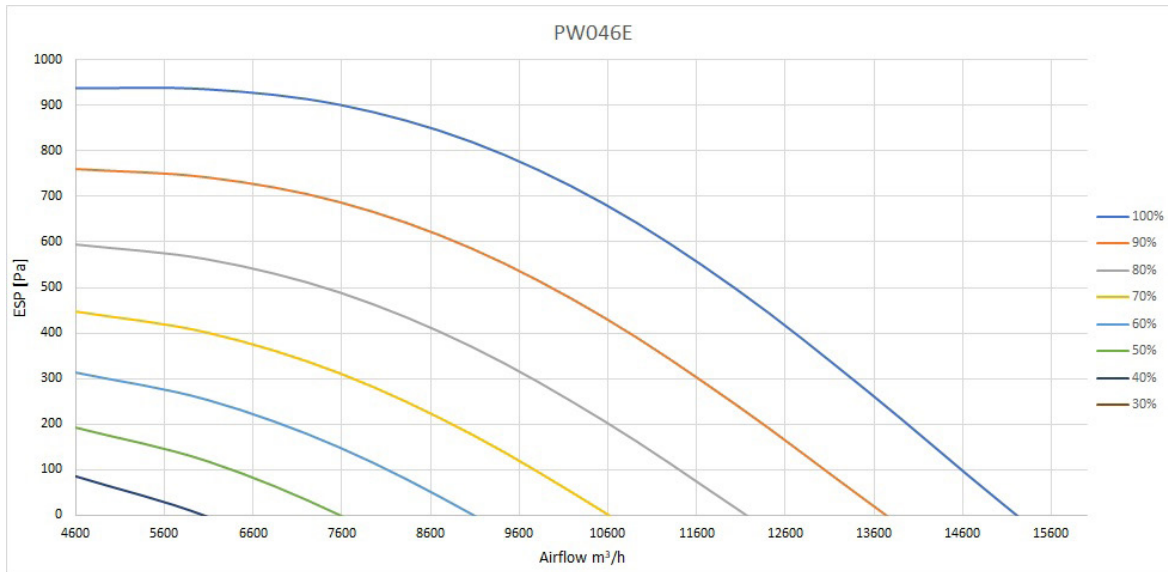

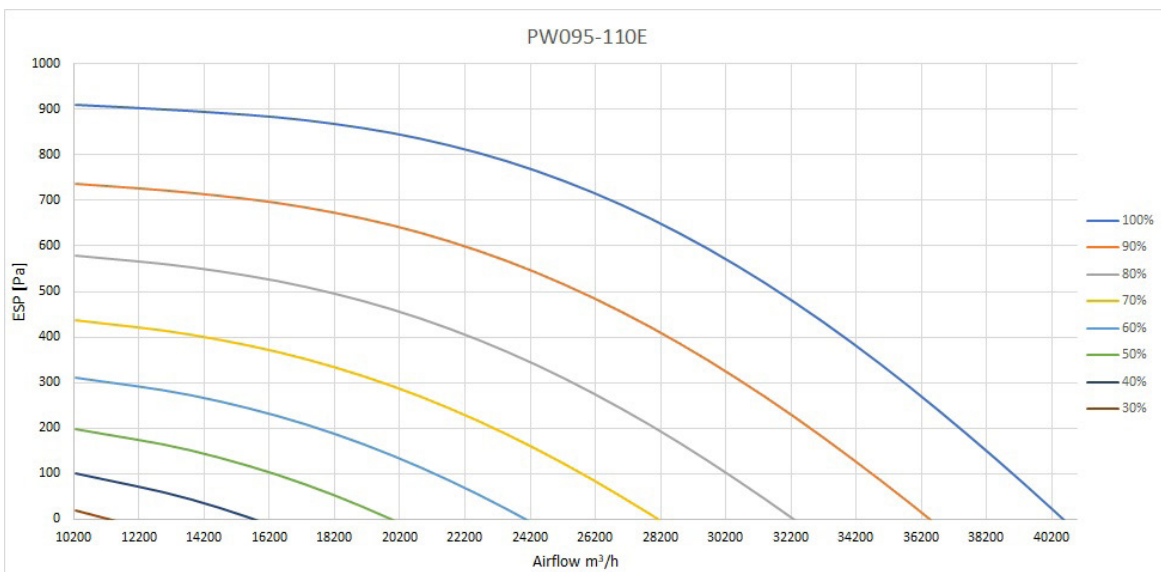
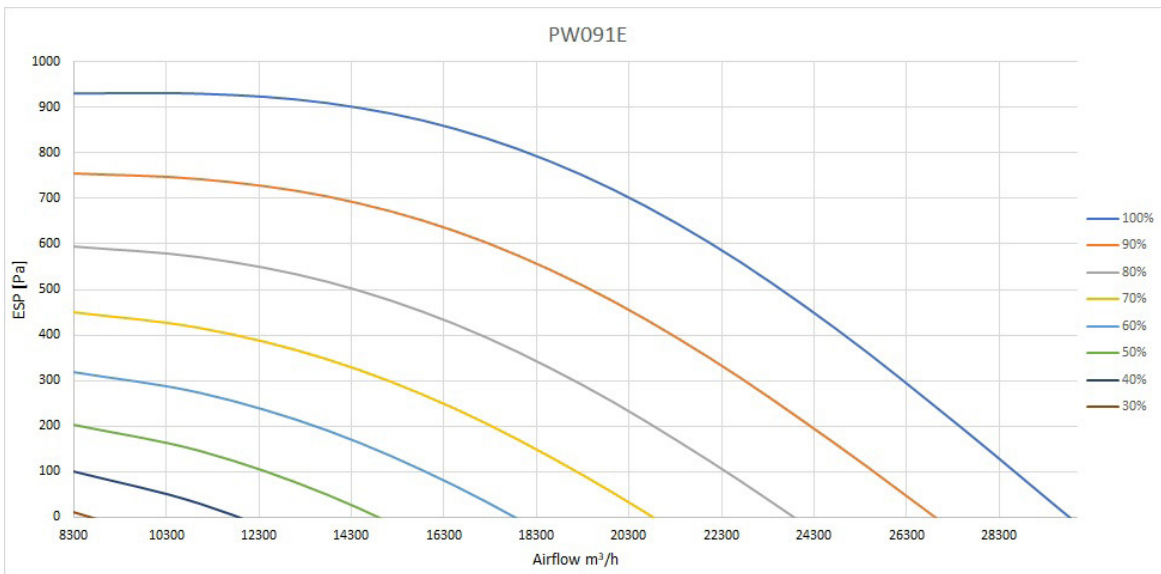
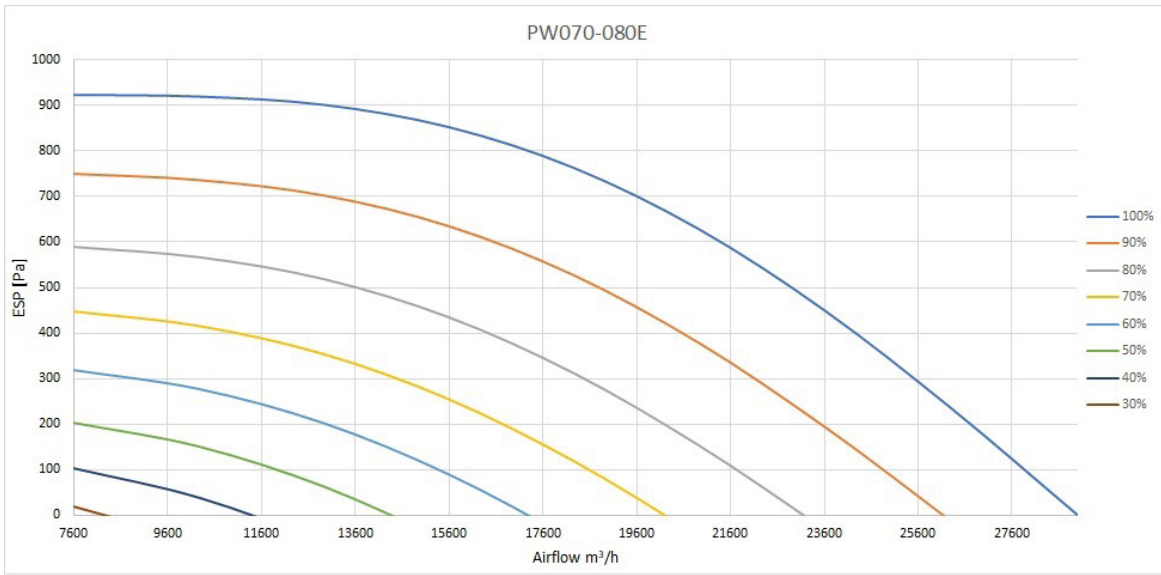

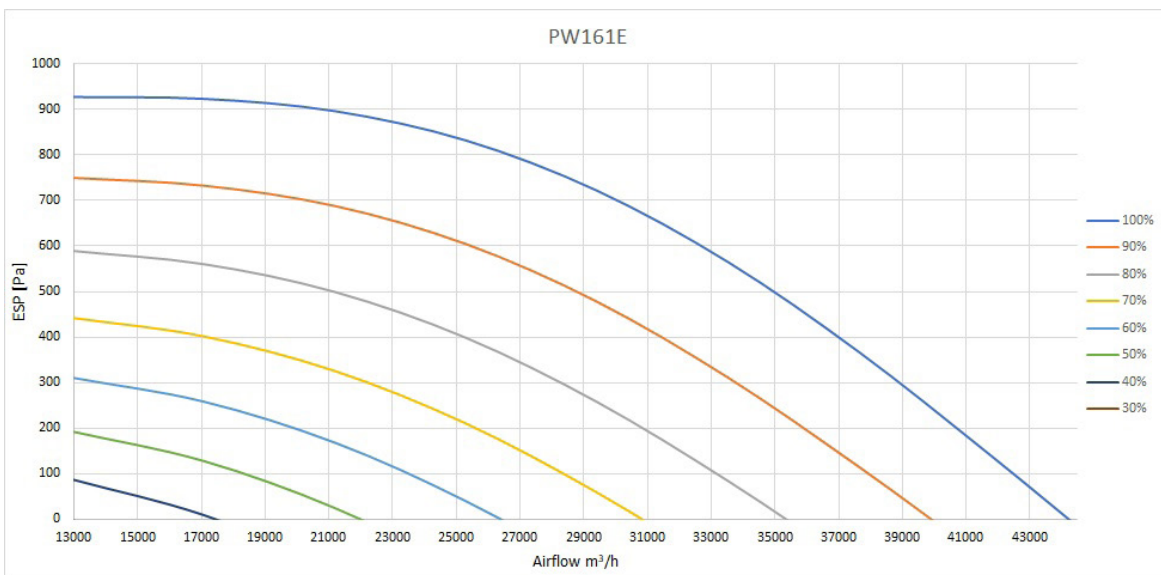
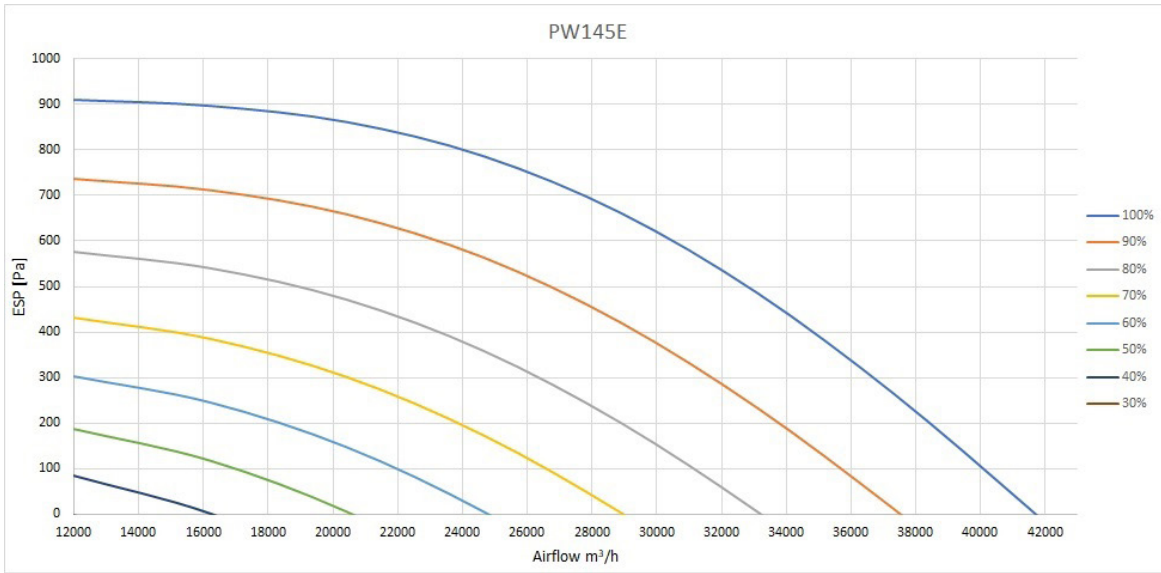
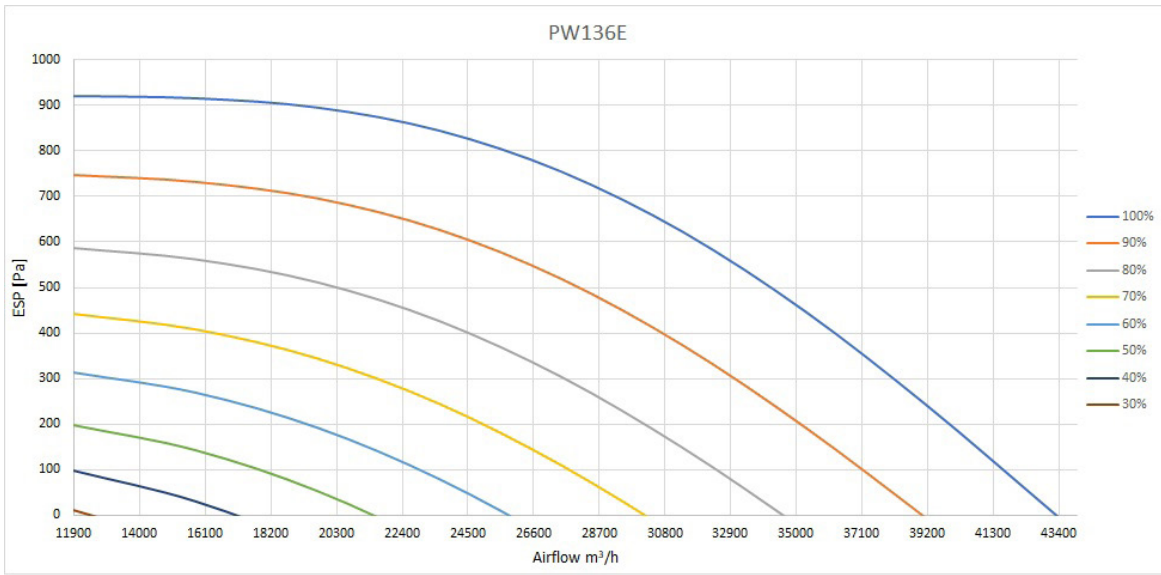

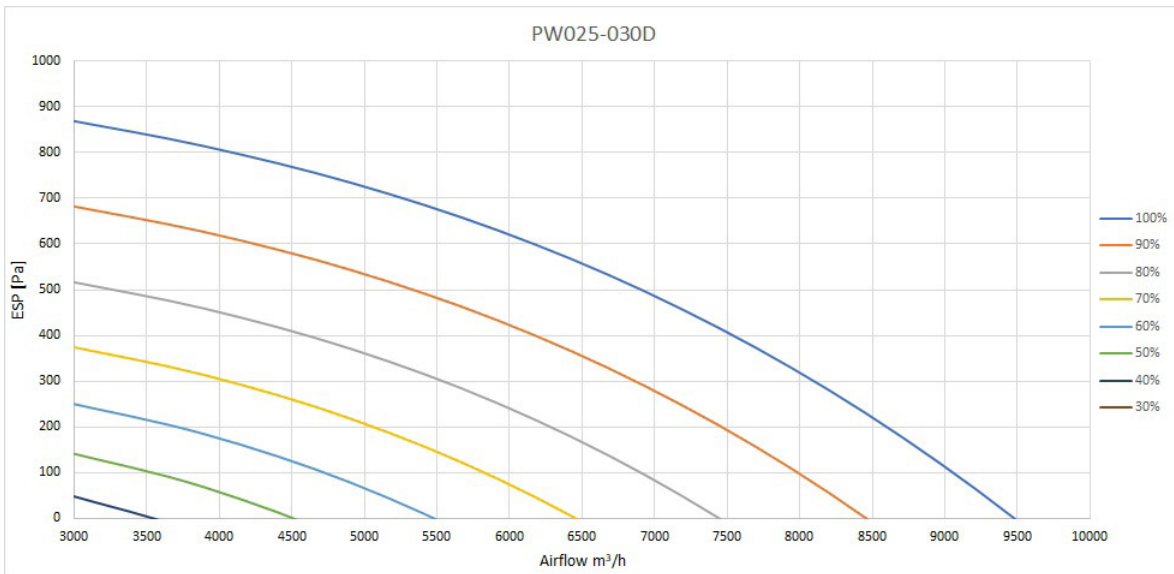
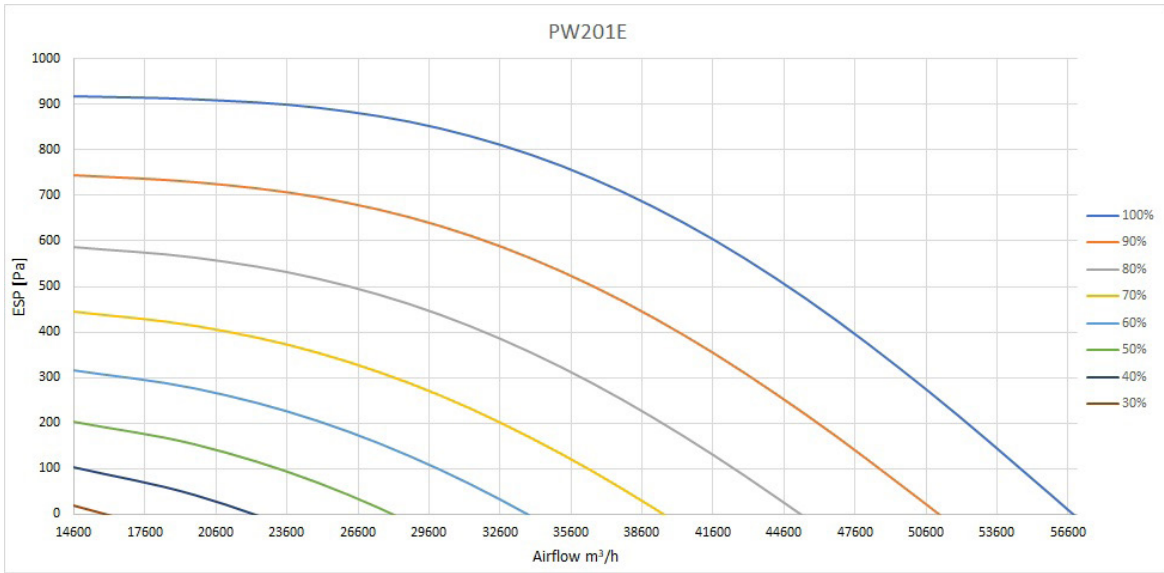
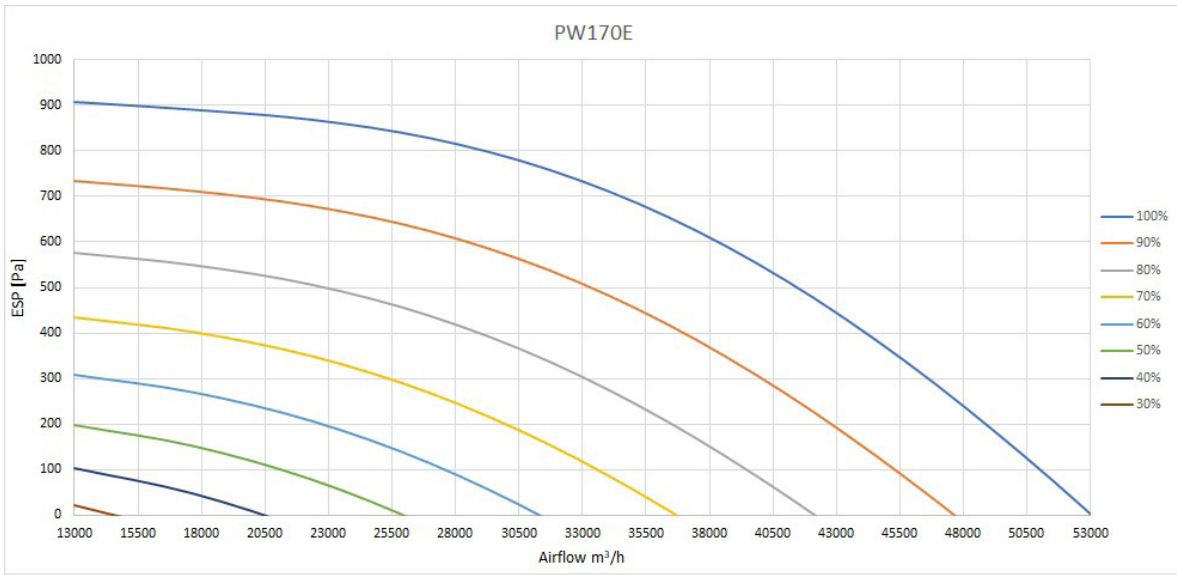

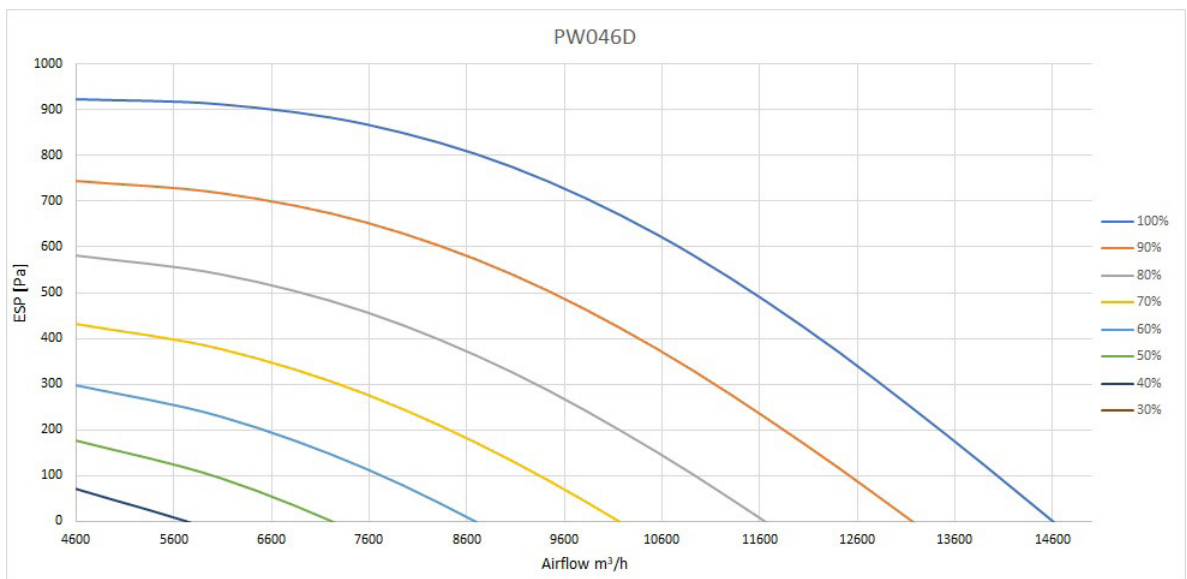
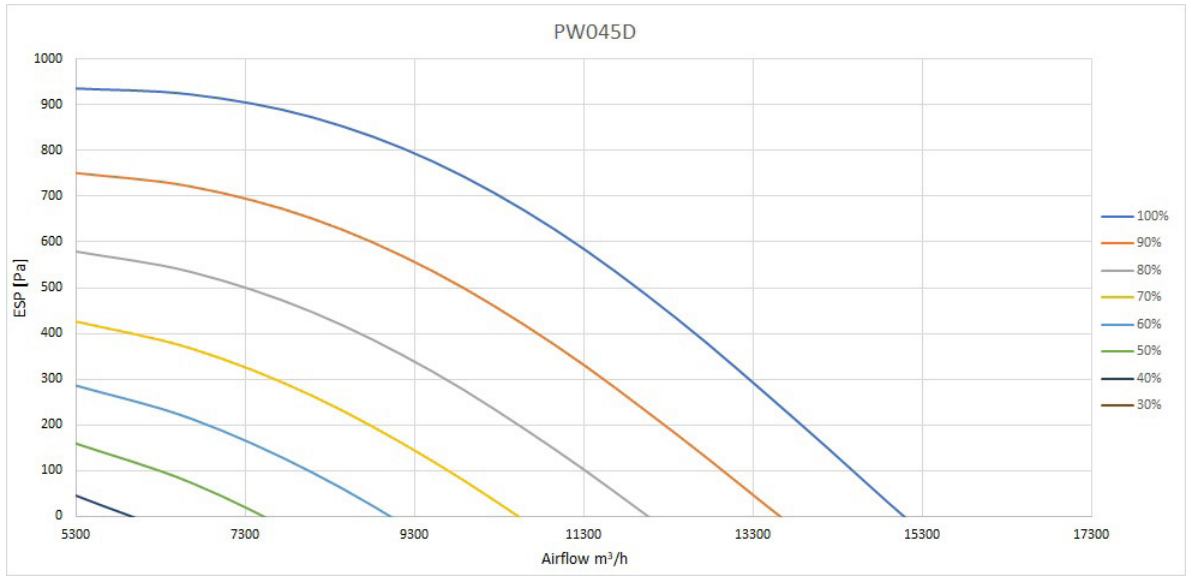
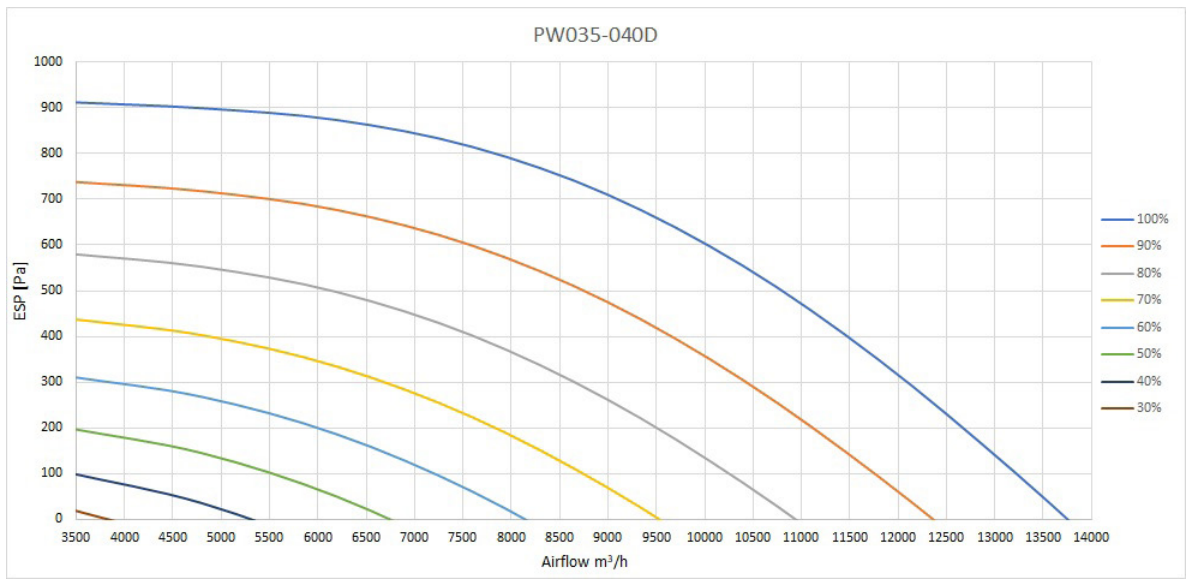

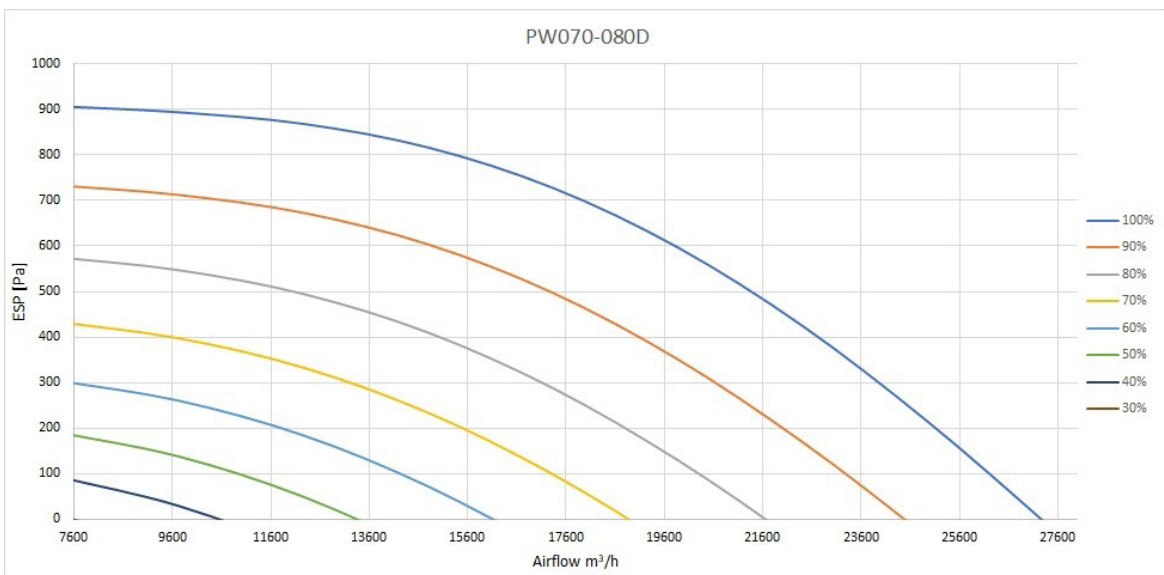
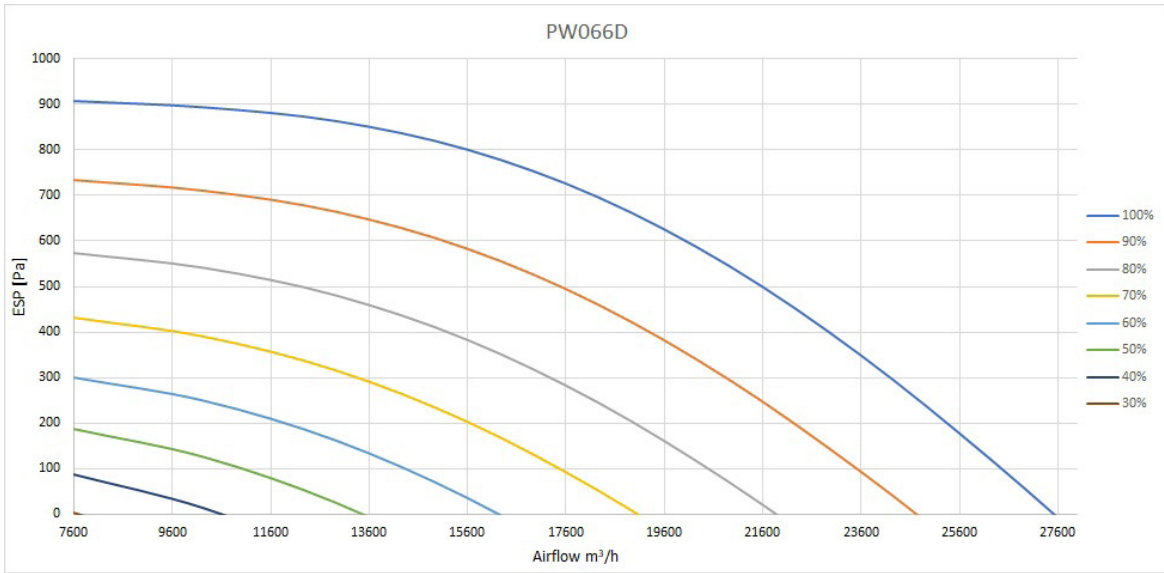
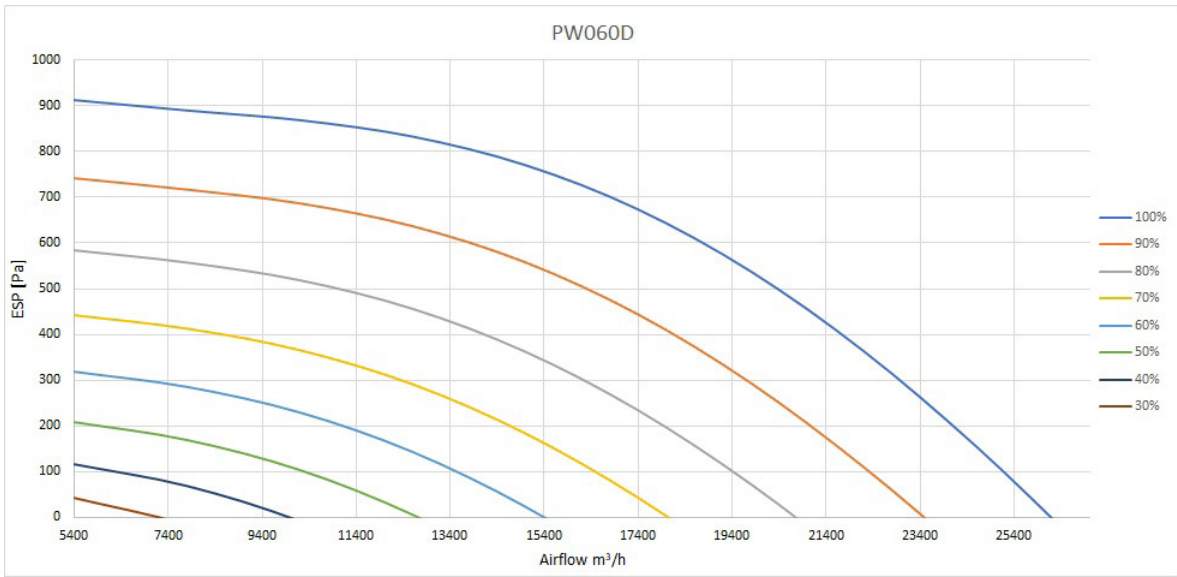

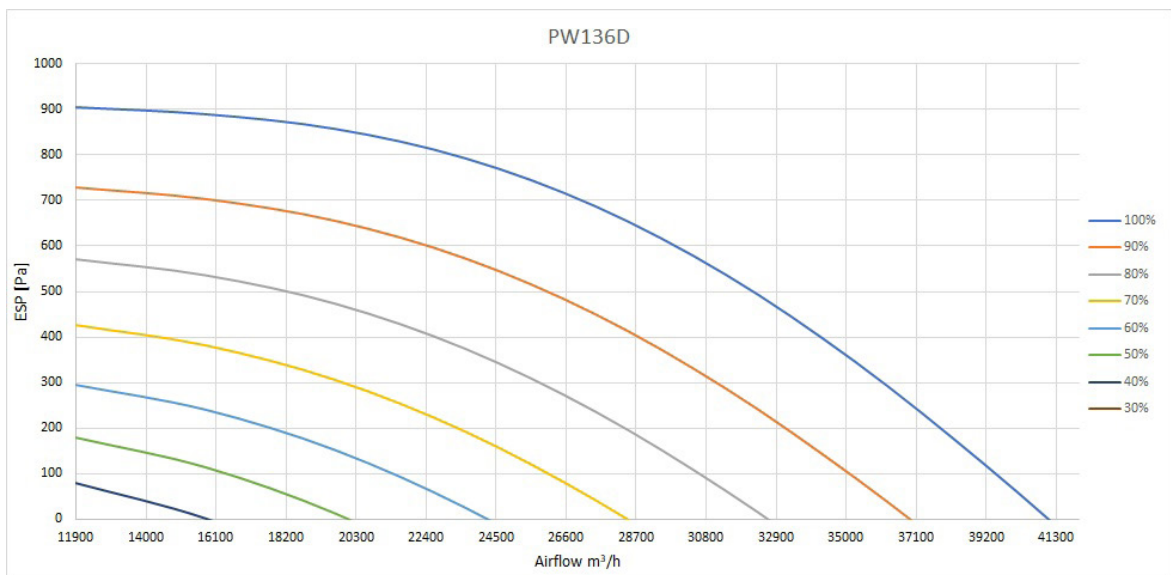
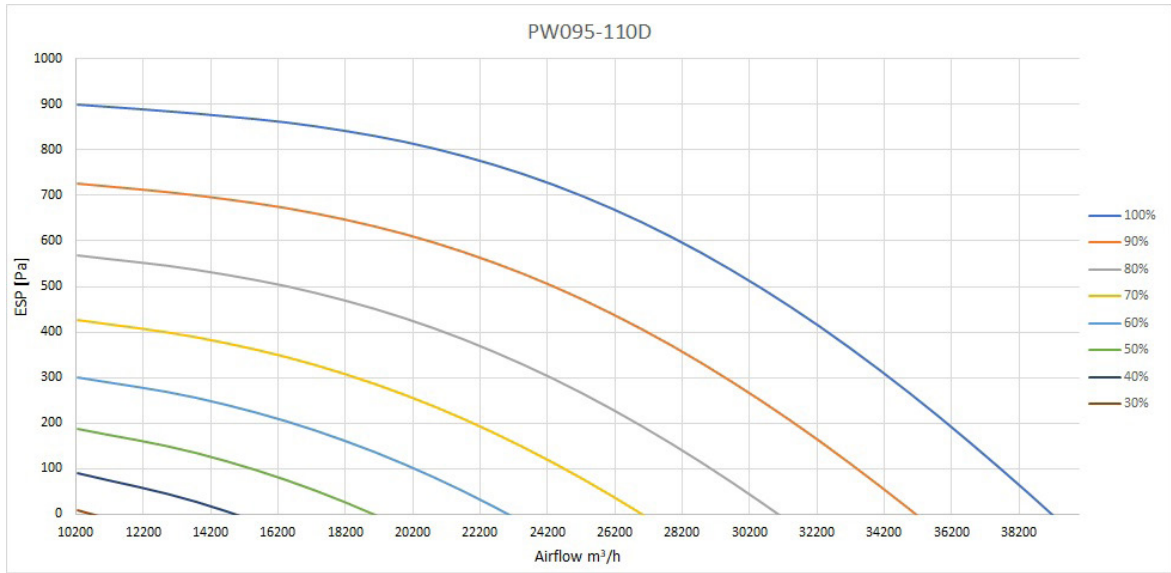
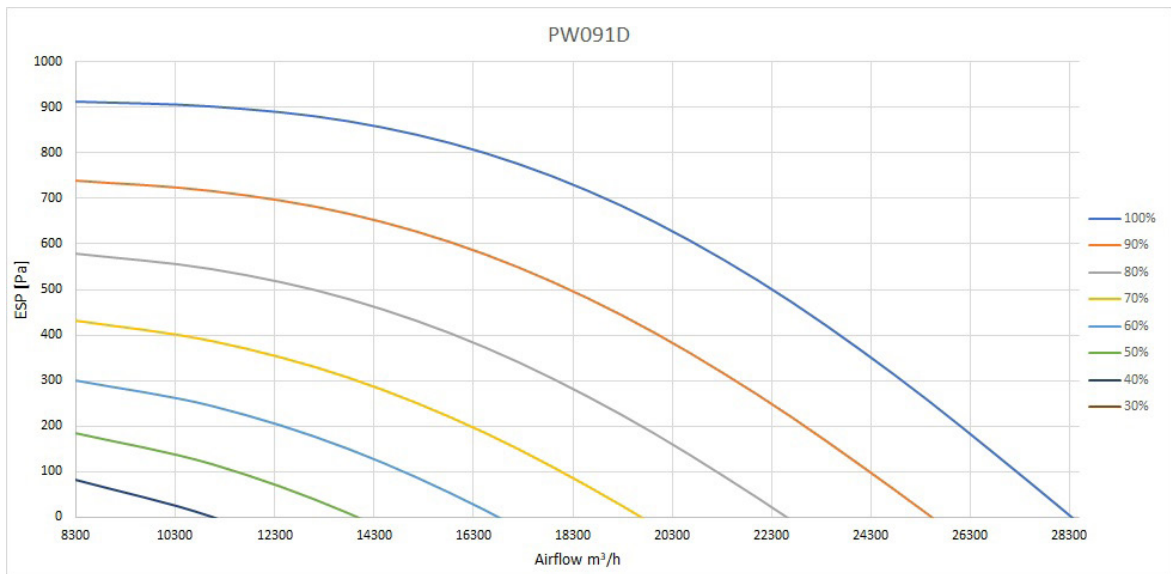

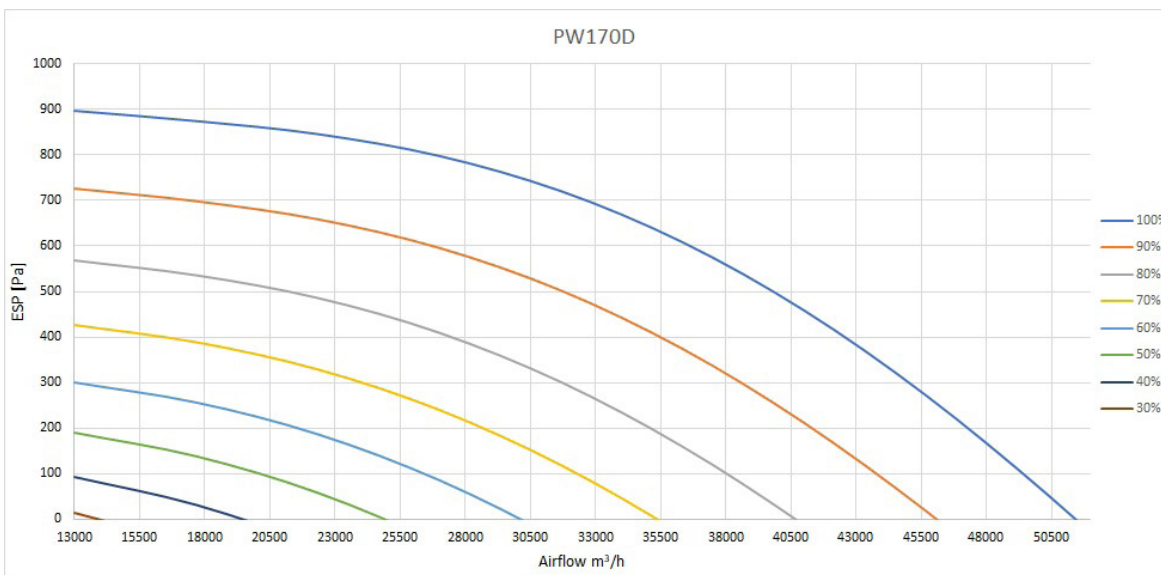
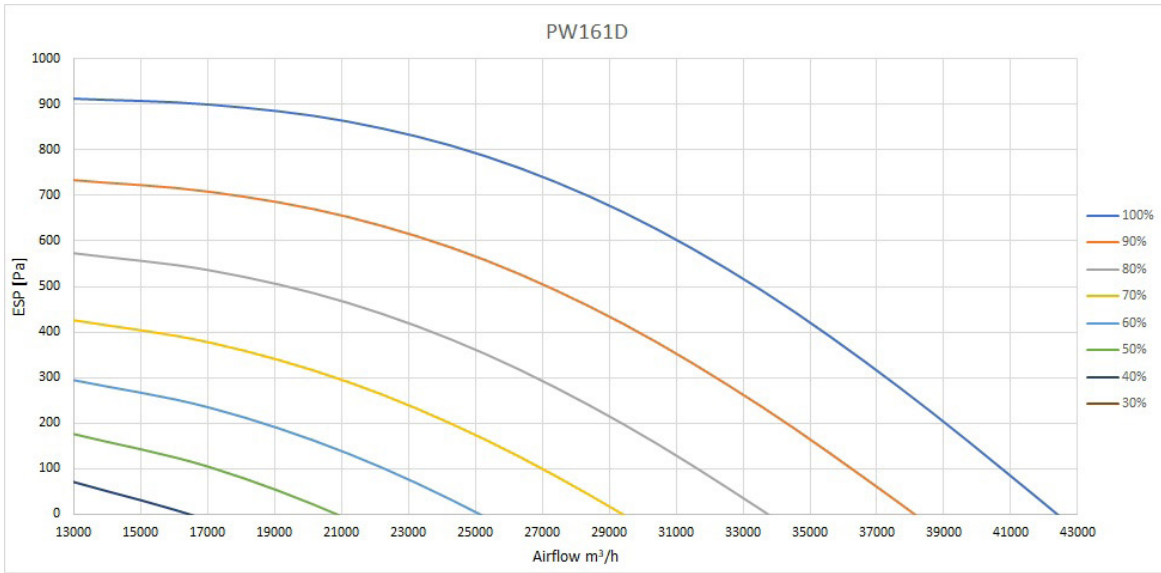
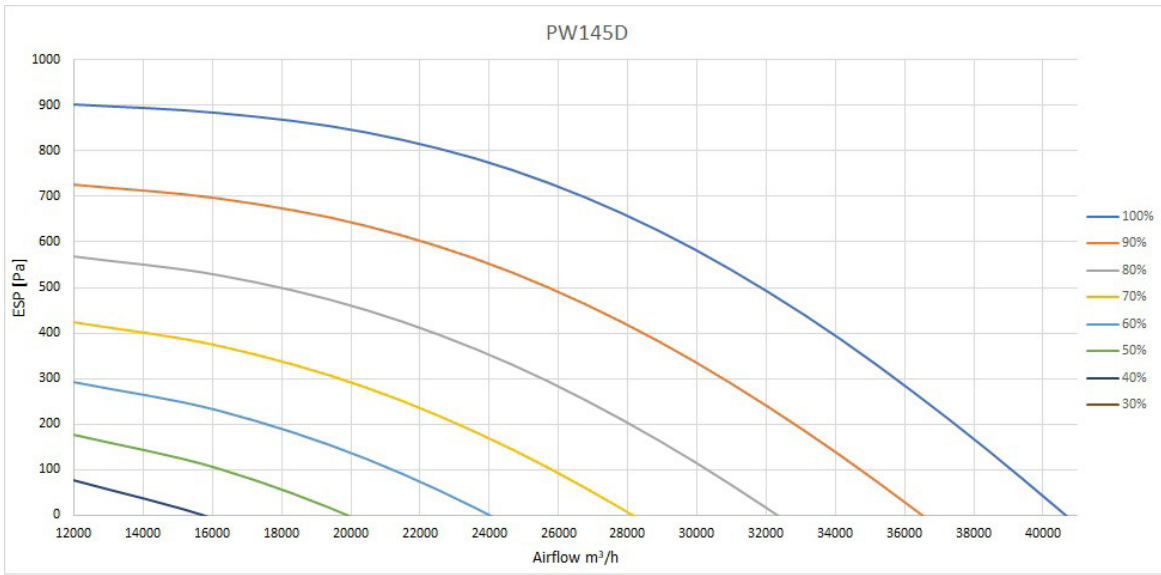

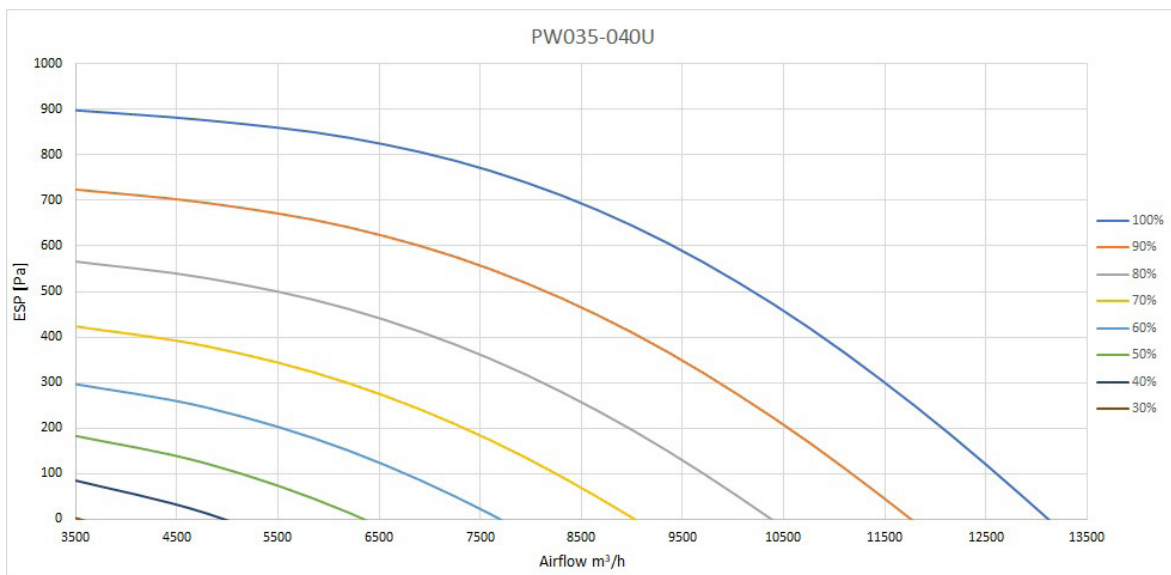
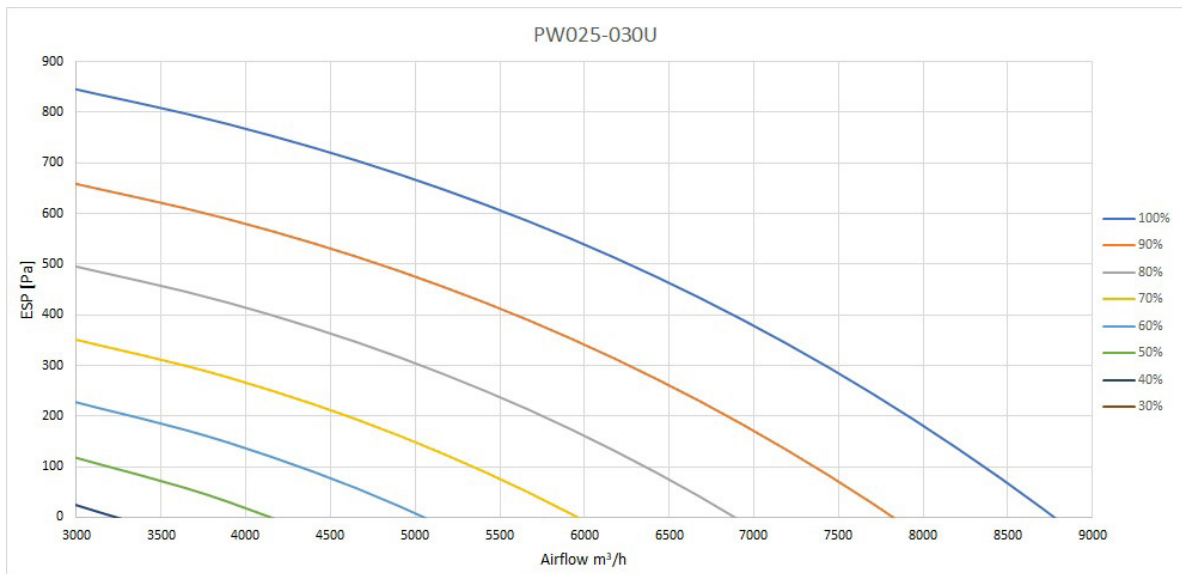
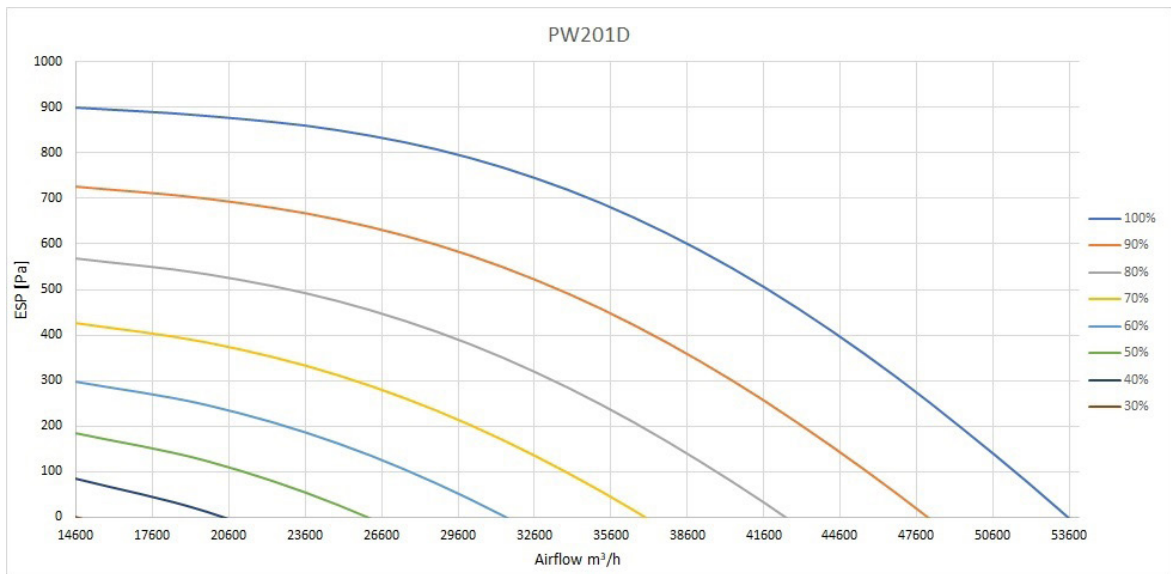

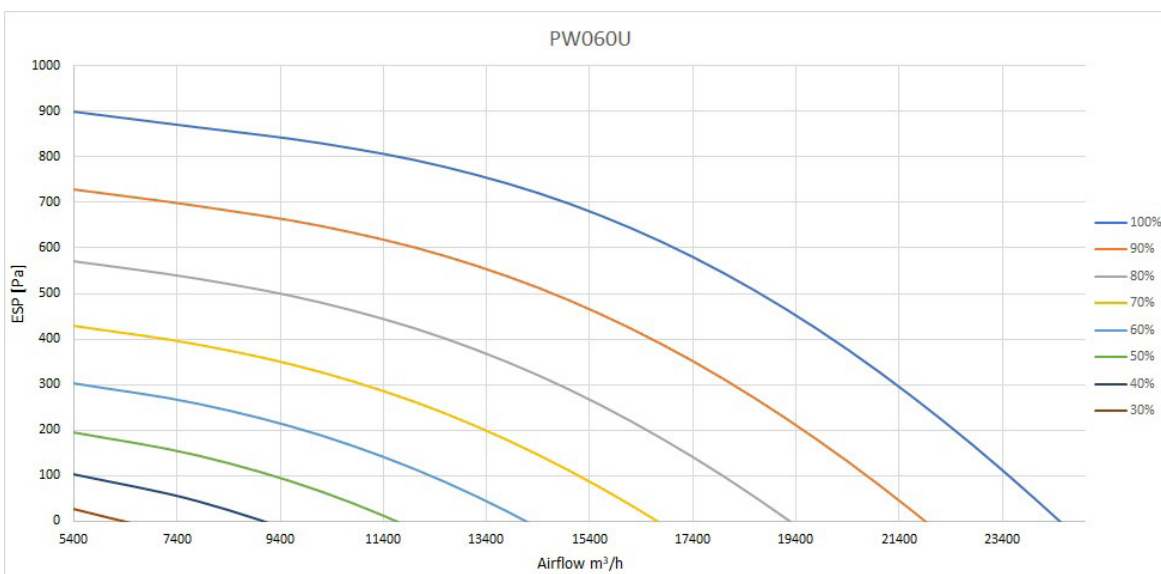
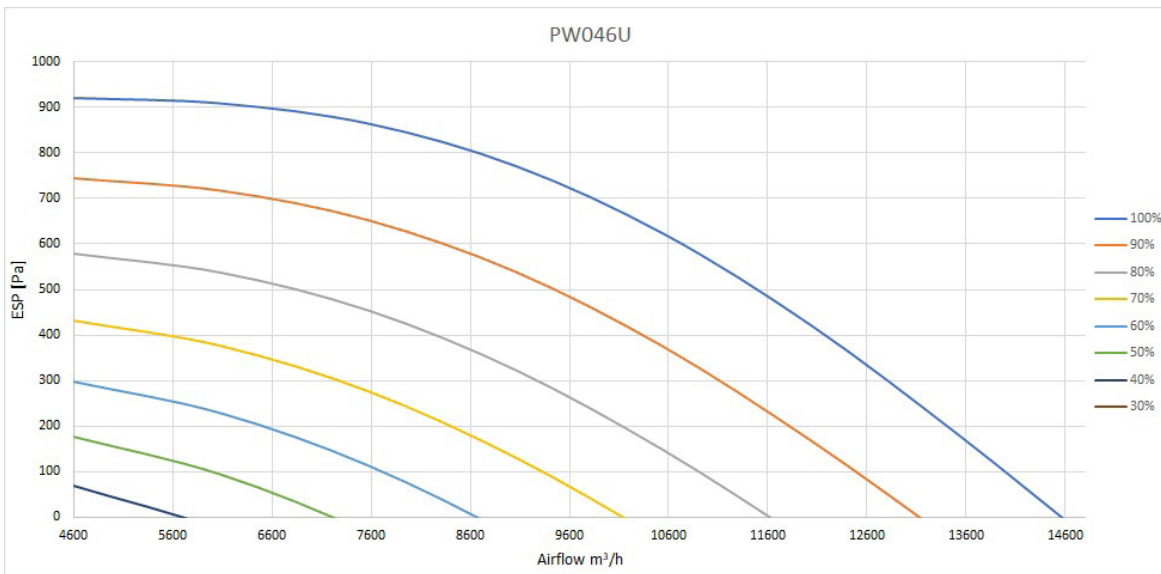
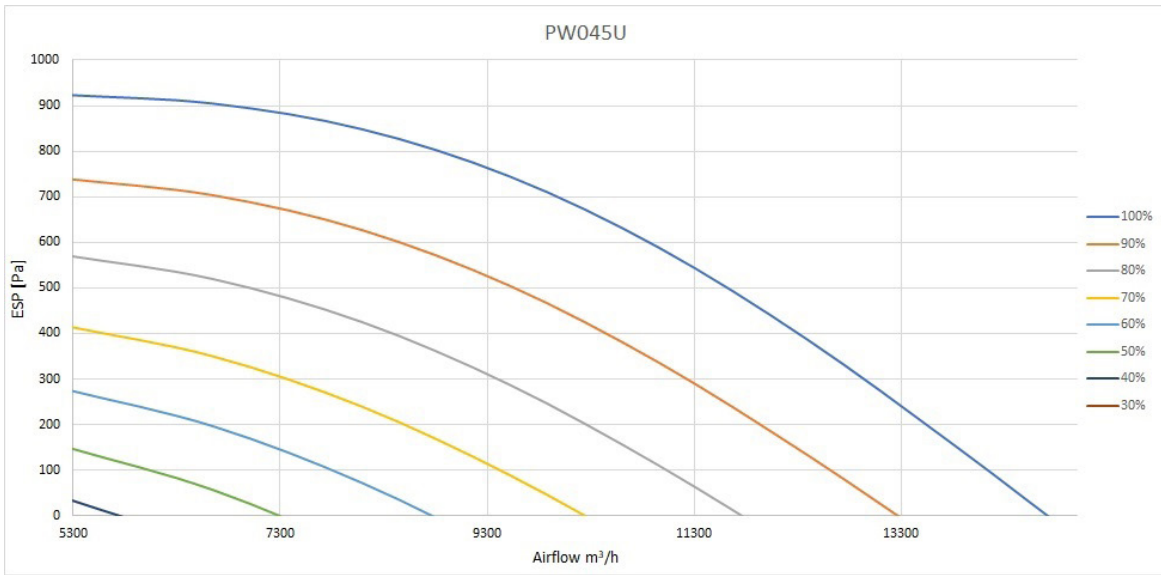

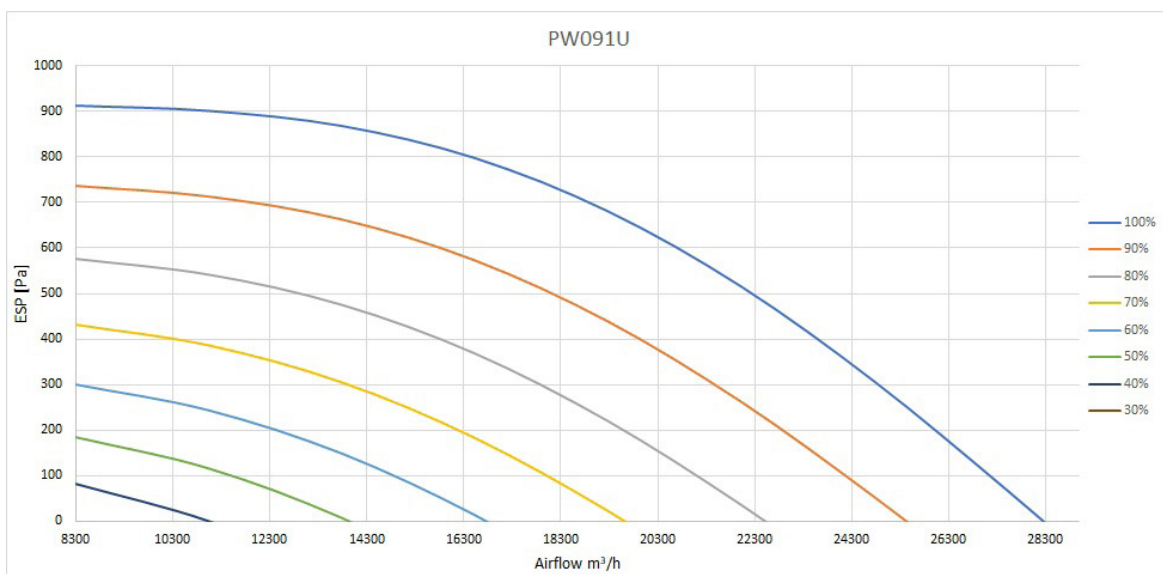
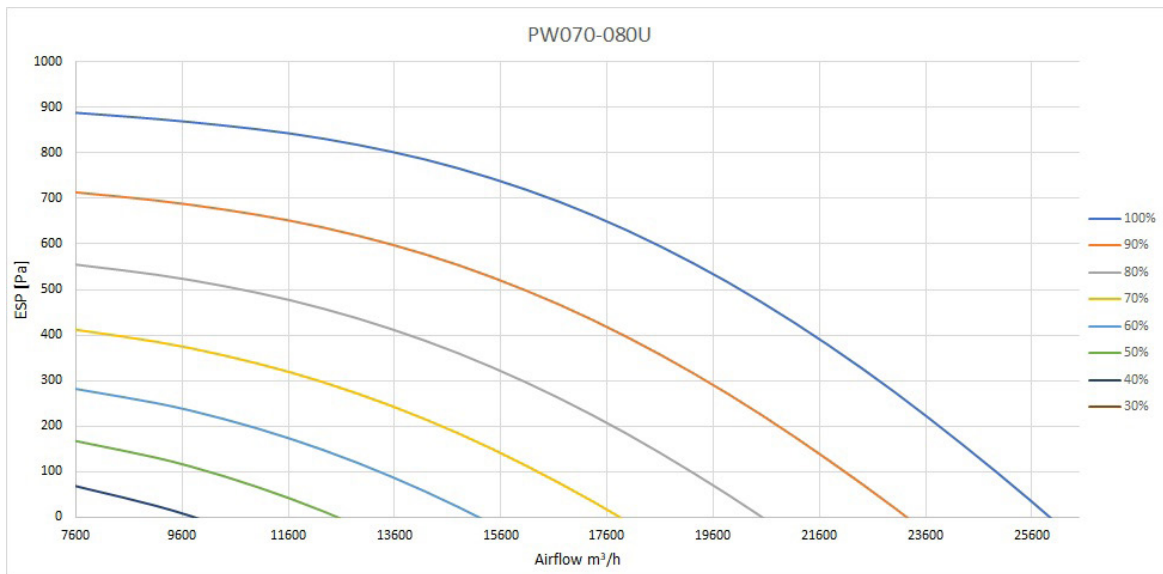
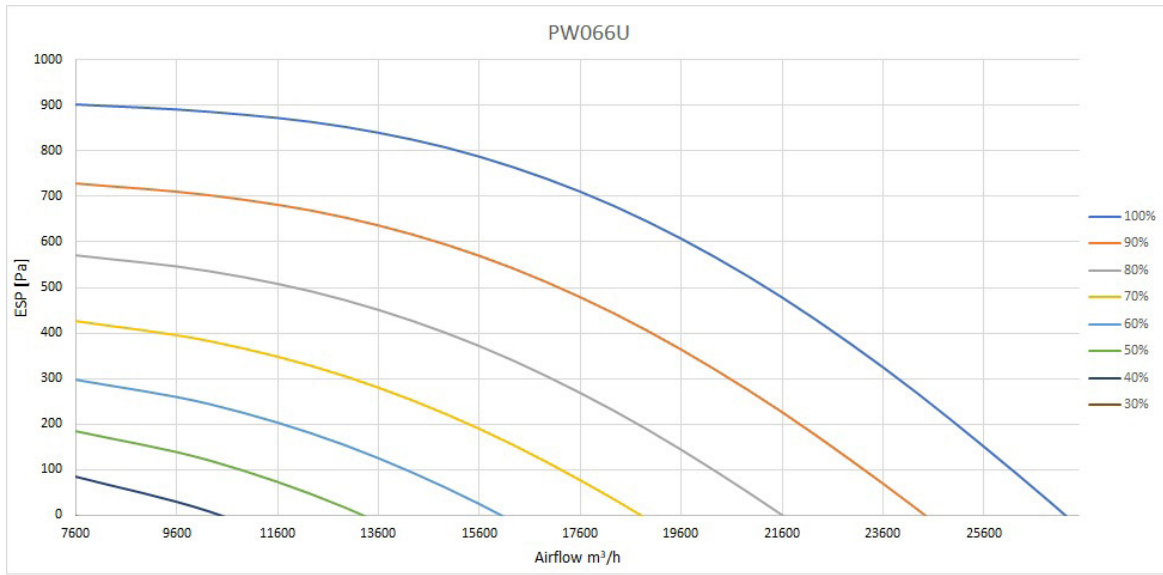

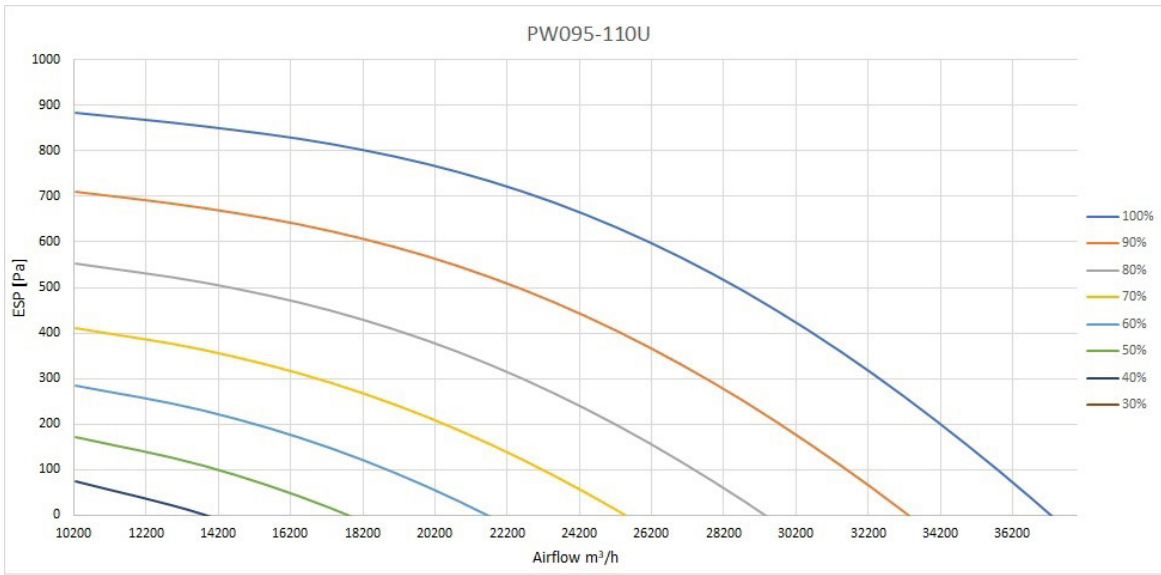

Fans electrical data

| Unit model | EC fan advance - HE | | | EC fan advance - HP | | |
|----------------------|---------------------|---------------------|---------------------|---------------------|---------------------|---------------------|
| | Motor Size [kW] | FLA @400V/ 50Hz [A] | FLA @460V/ 60Hz [A] | Motor Size [kW] | FLA @400V/ 50Hz [A] | FLA @460V/ 60Hz [A] |
| PW025 | 2,60 | 4,00 | 3,47 | 3,50 | 5,10 | 4,10 |
| PW030 | 2,60 | 4,00 | 3,47 | 3,50 | 5,10 | 4,10 |
| All remaining models | 3,50 | 5,10 | 4,10 | 3,50 | 5,32 | 4,62 |
| PW400 | 2,65 | 4,10 | 4,10 | 3,70 | 5,70 | 5,70 |

NOTE Values given for each single fan. The model is the same both for 50 Hz and 60 Hz.

5.3 Water Connections

5.3.1 Chilled Water Connections

The hydraulic connections are drawn in order to avoid any interference with fans replacement. In terms of chilled water connections small frame (up to frame 3 for Single Circuit or up to frame 4 for Dual Circuit) are supplied with threaded connections. For the other frames units are supplied with Victaulic connections, two smooth pipe stubs are provided with the units and can be used to create the connection.

Victaulic - Smooth Connections

Standard
Victaulic

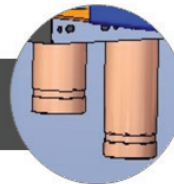

Standard
Smooth

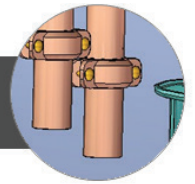

Threaded Connections – optional

Two threaded pipes can be supplied when the standard connections are Victaulic.

Threaded

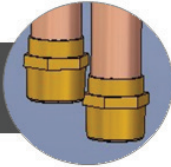

Flanges Pipe Connections – Accessories

Bimetal flanges can be supplied separately with external thread in order to suit easily with unit.

The flanges respect PN16 rated with 4 holes of 18mm.

Flanges

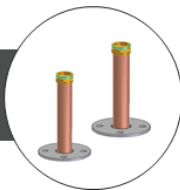

Bottom connections

The unit is provided with bottom left hydraulic connections. Dual circuit units provided with bottom left and right hydraulic connections.

Top connections

The unit is provided with top left hydraulic connections.

Lateral connections

The unit is provided with lateral coil section (left side) hydraulic connect.

5.3.2 Hot Water Connections (optional)



- Copper piping connection ready to connect by brazing;
- Hot Water Reheating Connections Are O. D. 22 Mm (0.87") Copper.

5.4 Condensate Pump (optional)

Unit is fitted with condensate pump to allow condensate removal. Two condensate pumps are installed for redundancy avoiding any water risk in the rooms. Each pump shall have a capacity of 50 l/h at 3.7 m head. Pump is completed with integral float switch, pump – motor assembly and reservoir. In case of alarm the unit can react stopping the unit, locking the humidifier or raising the alarm signal.

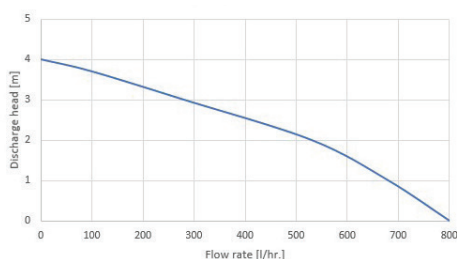
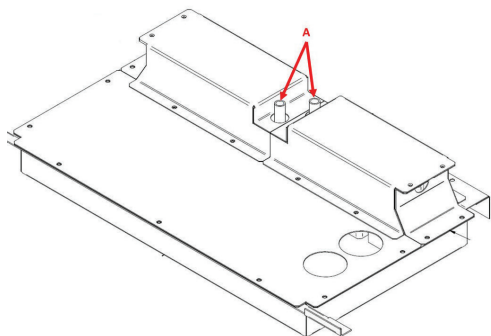

| Unit model | FLA [A] | Nominal Power [kW] |
|------------|---------|--------------------|
| All models | 1,6 | 0,15 |

NOTE

- Internal condensate pump kit available for 400 V / 3ph / 50 Hz and 380 V / 3ph / 60 Hz power supply.
- Internal condensate pump kit available for all units except Downflow PW025 and Downflow PW030.
- For 460 V / 3ph / 60 Hz available only external kit.

| Condensation pump kit | | | | | | |
|-----------------------|---|-----|-----|-----|-----|-----|
| Discharge head [m] | 4 | 3.7 | 3 | 2 | 1 | 0 |
| Flow rate [l/hr.] | 0 | 100 | 280 | 530 | 680 | 800 |

5.5 Water Temperature Sensors & Flow Meter (optional)

Water Temperature Sensors

Unit is fitted with water inlet and water outlet NTC temperature sensors. Water temperatures values can be available on display and shared with BMS system if monitoring card is present.

Water Temperature Sensors & Flow Meter

Unit is fitted with water inlet and water outlet NTC temperature sensors and with water flow meter. This allows the unit to calculate and display unit cooling gross capacity. Water temperatures and cooling gross capacity values can be available on display and shared with BMS system if monitoring card is present.

| Measured item | Unit | Measuring range | Expected error range |
|--------------------------|---------------|-----------------|----------------------|
| Water Temperature | all | 5 ÷ 35° C | ± 0,2° C |
| Water Flow | PW025...PW046 | 0,8 ÷ 4,0 l/s | ± 0,20 l/s |
| | PW045...PW066 | 1,2 ÷ 6,0 l/s | ± 0,30 l/s |
| | PW070...PW091 | 2,0 ÷ 10,2 l/s | ± 0,50 l/s |
| | PW095...PW201 | 2,8 ÷ 14,1 l/s | ± 0,70 l/s |
| | PW400 | 4,8 ÷ 19,2 l/s | ± 1,152 l/s |

Water Temperature Sensors & PICV

Unit fitted with pressure independent control valve can provide water flow value. Combining it with the water temperature sensors allows to calculate and display unit cooling gross capacity. Cooling gross capacity value can be available on display and shared with BMS system if monitoring card is present.

5.6 Energy Meter (optional)

Device

Unit is fitted with Energy Meter class 1 for active energy.

Unit Power Consumptions Calculator – Option

Unit power consumptions can be calculated thanks to the direct communication between the control and the EC fans motor. This specific algorithm calculates the entire unit power consumption with an accuracy of ± 5% at the nominal conditions. This feature is available for only cooling units.

6. Sound Pressure Level

Content of this chapter

| | | | |
|--------------------------------------|----|---|----|
| 6.1 Introduction..... | 51 | 6.3 Plenum with Silencing Cartridges (Accessory)..... | 53 |
| 6.2 Sound Emission Spectra..... | 51 | 6.3.1 Features..... | 53 |
| 6.2.1 Upflow configuration..... | 52 | 6.3.2 Noise attenuation..... | 54 |
| 6.2.2 Downflow Up configuration..... | 53 | 6.3.3 Pressure drop..... | 54 |

6.1 Introduction

Liebert® PCW units have been designed with particular care for sound and vibration problems.

Highest ventilation efficiency combined with the lowest sound emission have been obtained by the following design criteria:

- optimization of the aeraulic circuit by accurate researches made in our thermodynamic laboratories, with special focus on coils and filters
- complete mechanical insulation of the ventilating section

6.2 Sound Emission Spectra

Test conditions

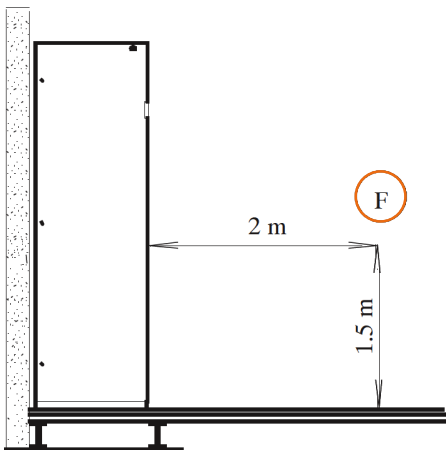

The noise levels refer to free field conditions.

The instrument is placed at point [F] as shown in the figure.

The operating conditions are the following:

- Downflow unit with underflow air discharge and 30 Pa available external static pressure.
- Upflow unit with ducted air discharge and 30 Pa available external static pressure.
- Maximum air flow with clean ePM10 50% filters.
- High power EC Fan Module
- Variable speed cooling system @100% cooling capacity.

All tests are performed in our laboratories.

Key for tables reading

The tables in this chapter show sound levels for every octave band frequency.

The sound levels (both global and for each octave band) are expressed in dB with a tolerance of (- 0/+2) dB.

The data are referred to the main used configurations; for different configurations consult Hirating software.

The following keys are used:

| | |
|----------------------------|--|
| PWL | Sound Power Level calculated according to ISO 3744 procedure method |
| SPL | Sound Pressure Level measured in free field conditions and at 1 meter from the unit according to ISO 3744 average method |
| Mode ⁽¹⁾ | Only ventilation, measured as explained in <i>Test conditions</i> above |

6.2.1 Downflow Up configuration

Sound Power Level [dB] - Upflow configuration, High Efficiency EC fan module, 80% modulation

| | Unit model | Measurement conditions: High Efficiency EC fan module, 80% of fan modulation | | | | | | | | | | Sound level db(A) |
|-------------|------------|--|------|------|------|------|------|------|------|------|-------|-------------------|
| | | Level | 31.5 | 63 | 125 | 250 | 500 | 1000 | 2000 | 4000 | 8000 | |
| Downflow Up | PW025 | PWL | 62.7 | 62.7 | 68.6 | 73.1 | 75.2 | 77.2 | 75.2 | 70.9 | 62.9 | 81.2 |
| | | SPL | 59.7 | 59.7 | 65.0 | 65.0 | 57.9 | 51.5 | 46.9 | 38.6 | 30.1 | 60.1 |
| | PW030 | PWL | 62.4 | 62.4 | 68.3 | 72.8 | 74.9 | 76.9 | 74.9 | 70.6 | 62.6 | 80.9 |
| | | SPL | 59.4 | 59.4 | 64.7 | 64.7 | 57.6 | 51.2 | 46.6 | 38.3 | 29.8 | 59.8 |
| | PW035 | PWL | 71.9 | 71.9 | 76.6 | 81.2 | 84.9 | 86.1 | 81.9 | 87.4 | 72.0 | 91.7 |
| | | SPL | 63.3 | 63.3 | 68.6 | 68.6 | 61.5 | 55.1 | 50.5 | 42.2 | 33.7 | 63.7 |
| | PW040 | PWL | 71.5 | 71.5 | 76.2 | 80.8 | 84.5 | 85.7 | 81.5 | 87.0 | 71.6 | 91.3 |
| | | SPL | 62.9 | 62.9 | 68.2 | 68.2 | 61.1 | 54.7 | 50.1 | 41.8 | 33.3 | 63.3 |
| | PW046 | PWL | 74.6 | 74.6 | 79.2 | 84.2 | 88.9 | 90.5 | 85.9 | 89.8 | 74.9 | 95.1 |
| | | SPL | 41.6 | 41.6 | 61.4 | 64.6 | 61.8 | 60.0 | 56.4 | 48.9 | 39.3 | 64.5 |
| | PW045 | PWL | 72.2 | 72.2 | 76.9 | 81.5 | 85.3 | 86.5 | 82.2 | 87.6 | 72.2 | 92.0 |
| | | SPL | 62.0 | 62.0 | 67.3 | 67.3 | 60.2 | 53.8 | 49.2 | 40.9 | 32.4 | 62.4 |
| | PW060 | PWL | 67.2 | 67.2 | 73.4 | 78.3 | 81.6 | 83.4 | 80.2 | 79.0 | 68.6 | 87.3 |
| | | SPL | 65.4 | 65.4 | 70.7 | 70.7 | 63.6 | 57.2 | 52.6 | 44.3 | 35.8 | 65.8 |
| | PW066 | PWL | 77.5 | 77.5 | 82.9 | 87.9 | 91.8 | 93.5 | 89.7 | 90.7 | 78.4 | 97.6 |
| | | SPL | 45.8 | 45.8 | 65.6 | 68.8 | 66.0 | 64.2 | 60.6 | 53.1 | 43.5 | 68.7 |
| | PW070 | PWL | 68.7 | 68.7 | 74.1 | 79.0 | 83.0 | 84.7 | 80.8 | 82.1 | 69.6 | 88.9 |
| | | SPL | 65.0 | 65.0 | 70.3 | 70.3 | 63.2 | 56.8 | 52.2 | 43.9 | 35.4 | 65.4 |
| | PW080 | PWL | 68.3 | 68.3 | 73.7 | 78.6 | 82.6 | 84.3 | 80.4 | 81.7 | 69.2 | 88.5 |
| | | SPL | 64.6 | 64.6 | 69.9 | 69.9 | 62.8 | 56.4 | 51.8 | 43.5 | 35.0 | 65.0 |
| | PW091 | PWL | 77.9 | 77.9 | 82.9 | 87.9 | 92.3 | 93.9 | 89.7 | 92.1 | 78.5 | 98.3 |
| | | SPL | 44.9 | 44.9 | 64.7 | 67.9 | 65.1 | 63.3 | 59.7 | 52.2 | 42.6 | 67.8 |
| | PW095 | PWL | 69.9 | 69.9 | 75.8 | 80.7 | 84.2 | 86.0 | 82.6 | 82.1 | 71.1 | 90.0 |
| | | SPL | 67.3 | 67.3 | 72.6 | 72.6 | 65.5 | 59.1 | 54.5 | 46.2 | 37.7 | 67.7 |
| | PW110 | PWL | 69.5 | 69.5 | 75.4 | 80.3 | 83.8 | 85.6 | 82.2 | 81.7 | 70.7 | 89.6 |
| | | SPL | 66.9 | 66.9 | 72.2 | 72.2 | 65.1 | 58.7 | 54.1 | 45.8 | 37.3 | 67.3 |
| | PW136 | PWL | 79.4 | 79.4 | 84.9 | 89.8 | 93.7 | 95.4 | 91.6 | 92.5 | 80.3 | 99.5 |
| | | SPL | 47.8 | 47.8 | 67.6 | 70.8 | 68.0 | 66.2 | 62.6 | 55.1 | 45.5 | 70.7 |
| PW145 | PWL | 69.7 | 69.7 | 75.3 | 80.3 | 84.0 | 85.8 | 82.1 | 82.4 | 70.7 | 89.8 | |
| | SPL | 66.1 | 66.1 | 71.4 | 71.4 | 64.3 | 57.9 | 53.3 | 45.0 | 36.5 | 66.5 | |
| PW161 | PWL | 79.8 | 79.8 | 84.9 | 89.9 | 94.2 | 95.8 | 91.6 | 93.9 | 80.5 | 100.1 | |
| | SPL | 47.0 | 47.0 | 66.8 | 70.0 | 67.2 | 65.4 | 61.8 | 54.3 | 44.7 | 69.9 | |
| PW170 | PWL | 72.3 | 72.3 | 78.7 | 80.7 | 81.7 | 84.3 | 83.5 | 78.0 | 70.7 | 88.7 | |
| | SPL | 70.0 | 70.0 | 75.3 | 75.3 | 68.2 | 61.8 | 57.2 | 48.9 | 40.4 | 70.4 | |
| PW201 | PWL | 81.2 | 81.2 | 87.0 | 91.9 | 95.5 | 97.3 | 93.8 | 93.6 | 82.4 | 101.3 | |
| | SPL | 50.1 | 50.1 | 69.9 | 73.1 | 70.3 | 68.5 | 64.9 | 57.4 | 47.8 | 73.0 | |

6.2.2 Upflow configuration

Sound Power Level [dB] - Upflow configuration, High Efficiency EC fan module, 80% modulation

| | Unit model | Measurement conditions: High Efficiency EC fan module, 80% of fan modulation | | | | | | | | | | Sound level db(A) |
|--------|------------|--|------|------|------|------|------|------|------|------|------|-------------------|
| | | Level | 31.5 | 63 | 125 | 250 | 500 | 1000 | 2000 | 4000 | 8000 | |
| Upflow | PW025 | PWL | 59.5 | 59.5 | 65.4 | 69.9 | 72.0 | 74.0 | 72.0 | 67.7 | 59.7 | 78.0 |
| | | SPL | 56.5 | 56.5 | 61.8 | 61.8 | 54.7 | 48.3 | 43.7 | 35.4 | 26.9 | 56.9 |
| | PW030 | PWL | 59.4 | 59.4 | 65.3 | 69.8 | 71.9 | 73.9 | 71.9 | 67.6 | 59.6 | 77.9 |
| | | SPL | 56.4 | 56.4 | 61.7 | 61.7 | 54.6 | 48.2 | 43.6 | 35.3 | 26.8 | 56.8 |
| | PW035 | PWL | 68.3 | 68.3 | 73.0 | 77.6 | 81.3 | 82.5 | 78.3 | 83.8 | 68.4 | 88.1 |
| | | SPL | 59.7 | 59.7 | 65.0 | 65.0 | 57.9 | 51.5 | 46.9 | 38.6 | 30.1 | 60.1 |
| | PW040 | PWL | 68.0 | 68.0 | 72.7 | 77.3 | 81.0 | 82.2 | 78.0 | 83.5 | 68.1 | 87.8 |
| | | SPL | 59.4 | 59.4 | 64.7 | 64.7 | 57.6 | 51.2 | 46.6 | 38.3 | 29.8 | 59.8 |
| | PW046 | PWL | 71.9 | 71.9 | 76.5 | 81.5 | 86.2 | 87.8 | 83.2 | 87.1 | 72.2 | 92.4 |
| | | SPL | 38.9 | 38.9 | 58.7 | 61.9 | 59.1 | 57.3 | 53.7 | 46.2 | 36.6 | 61.8 |
| | PW045 | PWL | 68.8 | 68.8 | 73.5 | 78.1 | 81.9 | 83.1 | 78.8 | 84.2 | 68.8 | 88.6 |
| | | SPL | 58.6 | 58.6 | 63.9 | 63.9 | 56.8 | 50.4 | 45.8 | 37.5 | 29.0 | 59.0 |
| | PW060 | PWL | 63.9 | 63.9 | 70.1 | 75.0 | 78.3 | 80.1 | 76.9 | 75.7 | 65.3 | 84.0 |
| | | SPL | 62.1 | 62.1 | 67.4 | 67.4 | 60.3 | 53.9 | 49.3 | 41.0 | 32.5 | 62.5 |
| | PW066 | PWL | 74.8 | 74.8 | 80.2 | 85.2 | 89.1 | 90.8 | 87.0 | 88.0 | 75.7 | 94.9 |
| | | SPL | 43.1 | 43.1 | 62.9 | 66.1 | 63.3 | 61.5 | 57.9 | 50.4 | 40.8 | 66.0 |
| | PW070 | PWL | 68.1 | 68.1 | 73.5 | 78.4 | 82.4 | 84.1 | 80.2 | 81.5 | 69.0 | 88.3 |
| | | SPL | 64.4 | 64.4 | 69.7 | 69.7 | 62.6 | 56.2 | 51.6 | 43.3 | 34.8 | 64.8 |
| | PW080 | PWL | 64.9 | 64.9 | 70.3 | 75.2 | 79.2 | 80.9 | 77.0 | 78.3 | 65.8 | 85.1 |
| | | SPL | 61.2 | 61.2 | 66.5 | 66.5 | 59.4 | 53.0 | 48.4 | 40.1 | 31.6 | 61.6 |
| PW091 | PWL | 75.3 | 75.3 | 80.3 | 85.3 | 89.7 | 91.3 | 87.1 | 89.5 | 75.9 | 95.7 | |
| | SPL | 42.3 | 42.3 | 62.1 | 65.3 | 62.5 | 60.7 | 57.1 | 49.6 | 40.0 | 65.2 | |
| PW095 | PWL | 66.7 | 66.7 | 72.6 | 77.5 | 81.0 | 82.8 | 79.4 | 78.9 | 67.9 | 86.8 | |
| | SPL | 64.1 | 64.1 | 69.4 | 69.4 | 62.3 | 55.9 | 51.3 | 43.0 | 34.5 | 64.5 | |
| PW110 | PWL | 66.5 | 66.5 | 72.4 | 77.3 | 80.8 | 82.6 | 79.2 | 78.7 | 67.7 | 86.6 | |
| | SPL | 63.9 | 63.9 | 69.2 | 69.2 | 62.1 | 55.7 | 51.1 | 42.8 | 34.3 | 64.3 | |

NOTE: The sound levels global and for each octave band are expressed in dB with a tolerance of (0/+2) dB.

PWL - Sound Power Level calculated according to ISO 3744 procedure method.

SPL - Sound Pressure Level measured in free field conditions and at 2 meters from the front of the unit and 1,5 meters above the surface according to ISO 3744 average method.

All Liebert® PCW units have very high noise emission at maximum airflow.

Relevant expected values of Sound level dB(A) for lower airflow can be found in technical literature and simulation software.

6.3 Plenum with Silencing Cartridges (Accessory)

An extension hood with silencing cartridges can be supplied on request and can be installed on top of the unit. It is available with 600mm height, it shall be the same design as the unit and consist of sandwich panels lined with non-flammable insulation material of class A1 EU, density 20 kg/m³.

Inside the plenum there are special cartridges made of self-extinguishing material with a high noise attenuation capacity. They are guaranteed against disintegration and release of particles friction of the air. Despite a small additional pressure drop, these cartridges provide a remarkable sound power level reduction. The plenum height is 600 mm.

See also Annex D - Accessories - 9 - Plenum with silencing cartridges.

6.3.1 Features

| | |
|-----------------------------------|-----------------|
| Dimensions of the cartridges [mm] | 500 x 195 x 500 |
| Plenum height [mm] | 600 |
| Free section [mm] | 400 x 100 |

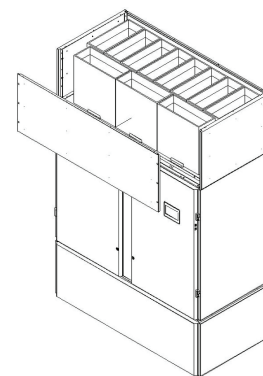

| Unit models | Number of cartridges per unit |
|---------------------------------------|-------------------------------|
| PW025 - PW030 | 4 |
| PW035 - PW040 - PW046 | 7 |
| PW045 - PW060 - PW066 | 11 |
| PW070 - PW080 - PW081 - PW091 - PW090 | 10 |
| PW095 - PW110 - PW111 - PW136 | 16 |
| PW145 - PW161 | 18 |
| PW170 - PW201 | 22 |

6.3.2 Noise attenuation

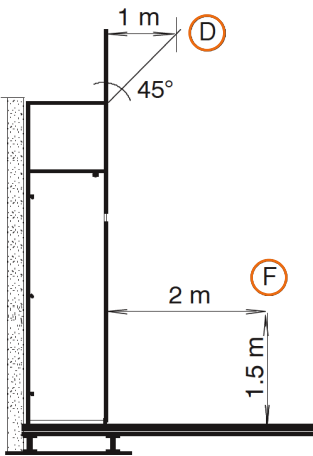

The following tables show Sound Pressure Level reduction for units with one row of silencing cartridges compared to the same units without silencing cartridges. The measurements are made at the positions [D] and [F] as shown in the figure.

| Unit configuration | SPL reduction | |
|--------------------|---------------|------------|
| | position D | position F |
| Downflow up | -7,0 dB | -4,0 dB |
| Upflow | -12,0 dB | -7,5 dB |

| Frequency band [Hz] | Attenuation on discharge PWL for one row of cartridges [dB]' |
|---------------------|---|
| 63 | 1 |
| 125 | 4 |
| 250 | 7 |
| 500 | 15 |
| 1 000 | 26 |
| 2 000 | 28 |
| 4 000 | 27 |
| 8 000 | 14 |

6.3.3 Pressure drop

| Air flow [m³/s] | 0,2 | 0,3 | 0,4 | 0,5 | 0,6 |
|--|-----|-----|-----|-----|-----|
| Pressure drop [Pa] for one row of cartridges | 1 | 2 | 4 | 7 | 9 |

Annex A - Water Circuit Diagrams

Content

| | |
|---|----|
| 1 - Single chilled water circuit and hot water reheating coil (optional)..... | 56 |
| 2 - Single chilled water circuit and hot water reheating coil (optional)..... | 57 |
| 3 - Dual chilled water circuit and hot water reheating coil (optional)..... | 58 |

1 - Single chilled water circuit and hot water reheating coil (optional)

Single chilled water circuit

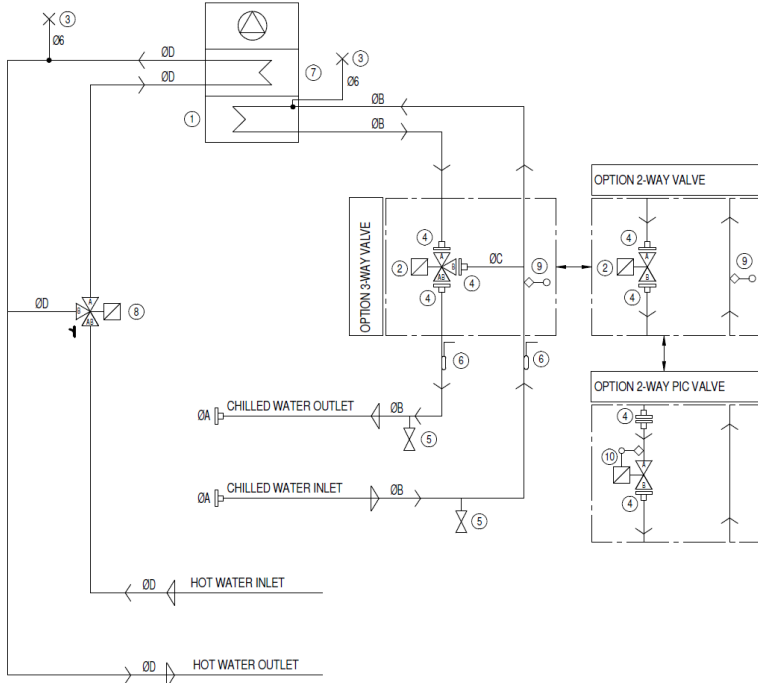

| Ref. | Description |
|------|---------------------------------|
| 1 | Chilled water cooling coil |
| 2 | Water valve |
| 3 | Manual air bleeding valve |
| 4 | Valve fittings |
| 5 | Drain valve |
| 6 | Water temperature sensor (opt.) |
| 7 | Reheating coil (opt.) |
| 8 | ON/OFF 3-way valve (opt.) |
| 9 | Flow transmitter (opt.) |
| 10 | PIC valve |

NOTE:

Flow meter is installed on inlet pipe before T connection on straight pipe part

| Unit name | Unit type | 2-way valve | | 3-way valve | | PICV | | ØA | ØB | ØC | ØD |
|-----------|-----------------|-------------|------|-------------|------|------|------|---------|----|----|----|
| | | DN | qty. | DN | qty. | DN | qty. | | | | |
| PW025 | Standard height | 25 | 1 | 25 | 1 | 32 | 1 | Rp 1 ¼" | 35 | 35 | 22 |
| PW030 | Standard height | 25 | 1 | 25 | 1 | 32 | 1 | Rp 1 ¼" | 35 | 35 | 22 |
| PW035 | Standard height | 32 | 1 | 32 | 1 | 40 | 1 | Rp 1 ¼" | 42 | 42 | 22 |
| PW040 | Standard height | 32 | 1 | 32 | 1 | 40 | 1 | Rp 1 ¼" | 42 | 42 | 22 |
| PW046 | Extended height | 32 | 1 | 32 | 1 | 40 | 1 | Rp 1 ¼" | 42 | 42 | 22 |
| PW045 | Standard height | 40 | 1 | 40 | 1 | 50 | 1 | Rp 1 ½" | 42 | 42 | 22 |
| PW060 | Standard height | 40 | 1 | 40 | 1 | 50 | 1 | Rp 1 ½" | 42 | 42 | 22 |
| PW066 | Extended height | 40 | 1 | 40 | 1 | 50 | 1 | Rp 1 ½" | 42 | 42 | 22 |
| PW070 | Standard height | 50 | 1 | 50 | 1 | 50 | 1 | 54 | 54 | 54 | 22 |
| PW080 | Standard height | 50 | 1 | 50 | 1 | 50 | 1 | 54 | 54 | 54 | 22 |
| PW091 | Extended height | 50 | 1 | 50 | 1 | 50 | 1 | 54 | 54 | 54 | 22 |

2 - Single chilled water circuit and hot water reheating coil (optional)

Single chilled water circuit

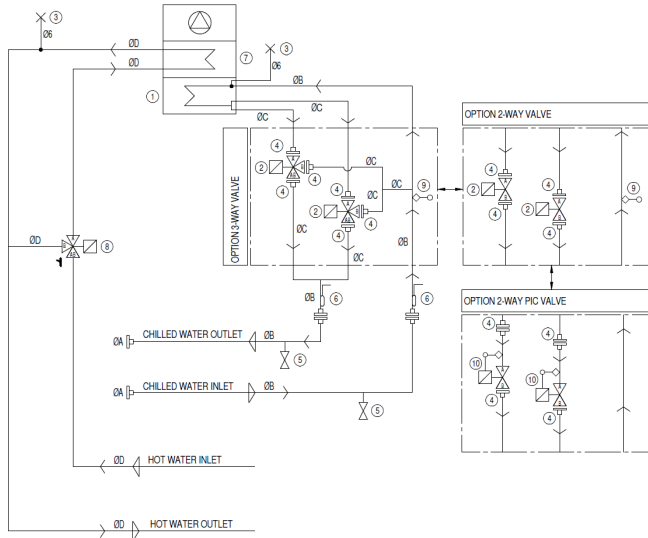

| Ref. | Description |
|------|---------------------------------|
| 1 | Chilled water cooling coil |
| 2 | Water valve |
| 3 | Manual air bleeding valve |
| 4 | Valve fittings |
| 5 | Drain valve |
| 6 | Water temperature sensor (opt.) |
| 7 | Reheating coil (opt.) |
| 8 | ON/OFF 3-way valve (opt.) |
| 9 | Flow transmitter (opt.) |
| 10 | PIC valve |

NOTE:

Flow meter is installed on inlet pipe before T connection on straight pipe part

| Unit name | Unit type | 2-way valve | | 3-way valve | | PICV | | ØA | ØB | ØC | ØD |
|-----------|-----------------|-------------|------|-------------|------|------|------|----|----|----|----|
| | | DN | qty. | DN | qty. | DN | qty. | | | | |
| PW095 | Standard height | 50 | 1 | 50 | 1 | 50 | 2 | 64 | 64 | 54 | 22 |
| PW110 | Standard height | 50 | 1 | 50 | 1 | 50 | 2 | 64 | 64 | 54 | 22 |
| PW136 | Extended height | 50 | 1 | 50 | 1 | 50 | 2 | 64 | 64 | 54 | 22 |
| PW145 | Standard height | 50 | 1 | 50 | 1 | 50 | 2 | 64 | 64 | 54 | 22 |
| PW161 | Extended height | 50 | 1 | 50 | 1 | 50 | 2 | 64 | 64 | 54 | 22 |
| PW170 | Standard height | 50 | 1 | 50 | 1 | 50 | 2 | 64 | 64 | 54 | 22 |
| PW201 | Extended height | 50 | 2 | 50 | 2 | 50 | 2 | 64 | 64 | 54 | 22 |

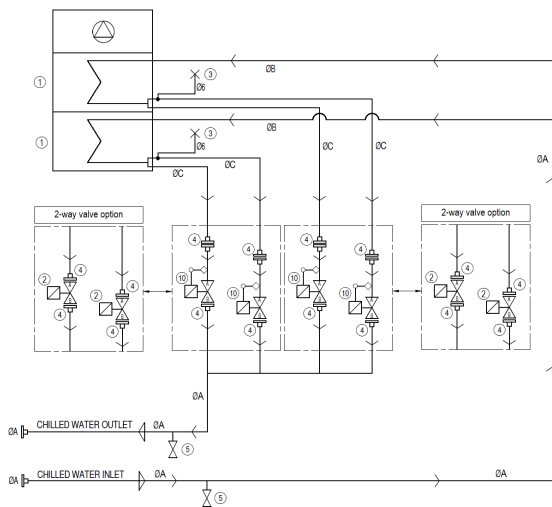

| Ref. | Description |
|------|---------------------------|
| 1 | Chilled water coil |
| 3 | Manual air bleeding valve |
| 4 | Valve fittings |
| 5 | Drain valve |
| 10 | Chilled water PIC valve |

| Unit name | Unit type | 2-way valve | | 3-way valve | | PICV | | ØA | ØB | ØC |
|-----------|-----------|-------------|------|-------------|------|------|------|----|----|----|
| | | DN | qty. | DN | qty. | DN | qty. | | | |
| PW400 | | | | | | | | 89 | 64 | 54 |

3 - Dual chilled water circuit and hot water reheating coil (optional)

Single chilled water circuit

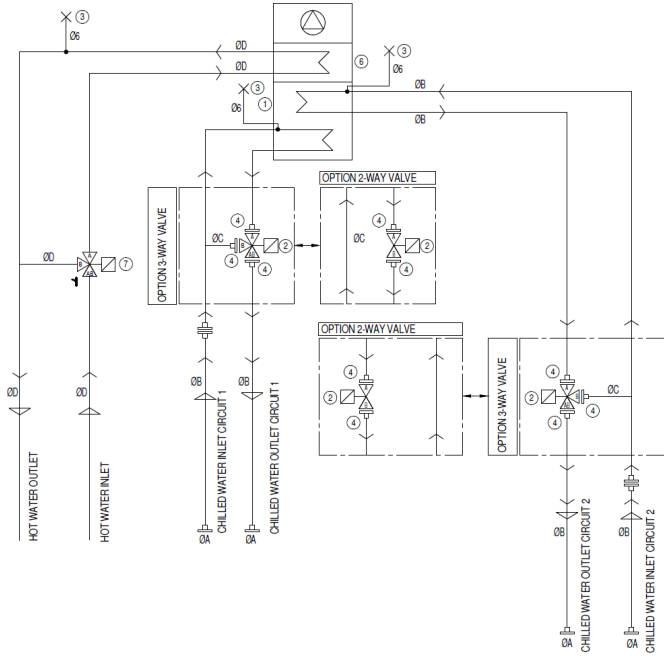

| Ref. | Description |
|------|---------------------------------|
| 1 | Chilled water cooling coil |
| 2 | Water valve |
| 3 | Manual air bleeding valve |
| 4 | Valve fittings |
| 5 | Drain valve |
| 6 | Water temperature sensor (opt.) |
| 7 | Reheating coil (opt.) |
| 8 | ON/OFF 3-way valve (opt.) |
| 9 | Flow transmitter (opt.) |

NOTE:

Flow meter is installed on inlet pipe before T connection on straight pipe part

| Unit name | Unit type | 2-way valve | | 3-way valve | | ØA | ØB | ØC | ØD |
|-----------|-----------------|-------------|-------|-------------|-------|---------|----|----|----|
| | | DN | qty. | DN | qty. | | | | |
| PW040 | Standard height | 32 | 1 + 1 | 32 | 1 + 1 | Rp 1 ¼" | 42 | 35 | 22 |
| PW046 | Extended height | 32 | 1 + 1 | 32 | 1 + 1 | Rp 1 ¼" | 42 | 35 | 22 |
| PW060 | Standard height | 40 | 1 + 1 | 40 | 1 + 1 | RP 1 ½" | 42 | 42 | 22 |
| PW066 | Extended height | 40 | 1 + 1 | 40 | 1 + 1 | Rp 1 ½" | 42 | 42 | 22 |
| PW080 | Standard height | 40 | 1 + 1 | 40 | 1 + 1 | Rp 1 ½" | 42 | 42 | 22 |
| PW091 | Extended height | 40 | 1 + 1 | 40 | 1 + 1 | Rp 1 ½" | 42 | 42 | 22 |
| PW110 | Standard height | 50 | 1 + 1 | 50 | 1 + 1 | 54 | 64 | 54 | 22 |
| PW136 | Extended height | 50 | 1 + 1 | 50 | 1 + 1 | 54 | 64 | 54 | 22 |
| PW145 | Standard height | 50 | 1 + 1 | 50 | 1 + 1 | 54 | 64 | 54 | 22 |
| PW161 | Extended height | 50 | 1 + 1 | 50 | 1 + 1 | 54 | 64 | 54 | 22 |
| PW170 | Standard height | 50 | 1 + 1 | 50 | 1 + 1 | 54 | 64 | 54 | 22 |
| PW201 | Extended height | 50 | 1 + 1 | 50 | 1 + 1 | 54 | 64 | 54 | 22 |

Annex B - Dimensions and Weights

Content

| | | | |
|--|----|--|----|
| 1 - Overall dimensions..... | 60 | 6 - Free space from the ceiling..... | 62 |
| 2 - Height from the floor..... | 60 | 7 - Hole in the floor for Downflow Up units..... | 63 |
| 3 - Height of the accessories at bottom..... | 61 | 8 - Hole in the floor for Downflow Down units..... | 64 |
| 4 - Height of the accessories on top..... | 61 | 9 - Weights..... | 65 |
| 5 - Free space from the floor..... | 62 | 10 - Unpacking..... | 67 |

1 - Overall dimensions

Standard units

Length by frame type (mm)

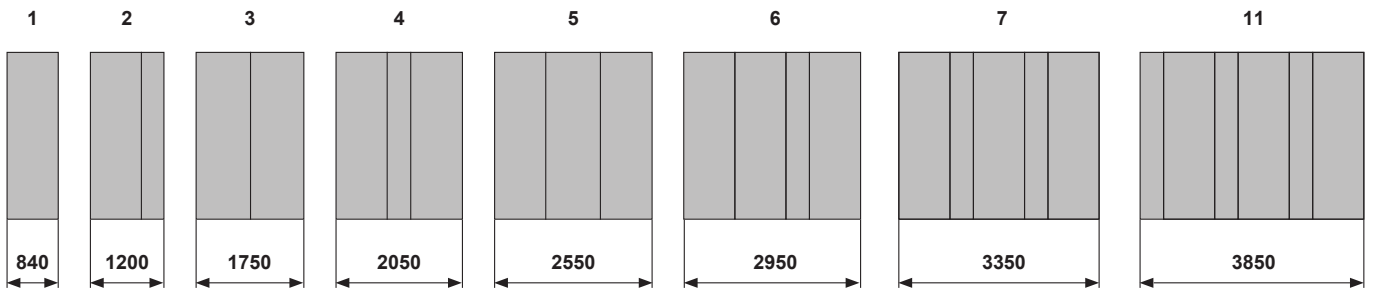

For all the frames types:

Depth 890 mm
 Standard height 1970 mm
 Extended height 2570 mm (not available for frame type 1)

PW 400 model:

Depth 1750 mm
 Standard height 1970 mm
 Extended height 3850 mm

NOTE In the units of frame type 1 the coil section and the fan section are integrated. In the units with frame types 2, 3, 5, 6 and 7 the coil section and the fan section are separate modules that are assembled together.

2 - Height from the floor

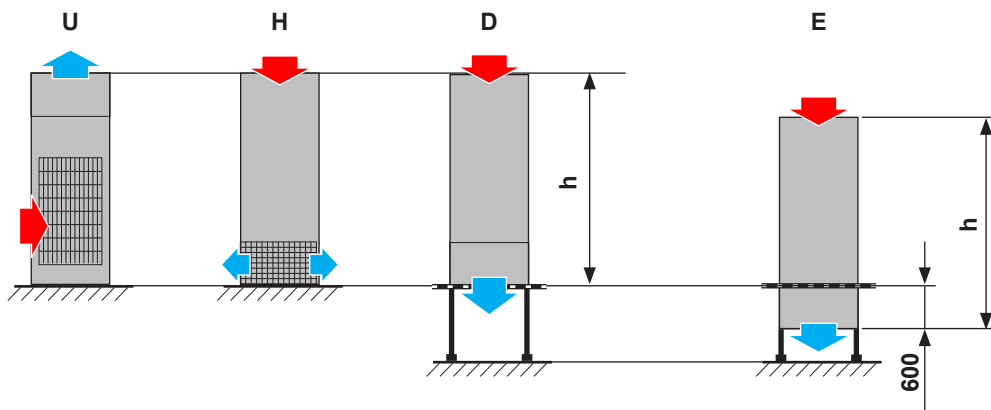

Standard h = 1970 mm
 Extended h = 2570 mm

The figure above shows the height from the floor for each air distribution configuration.

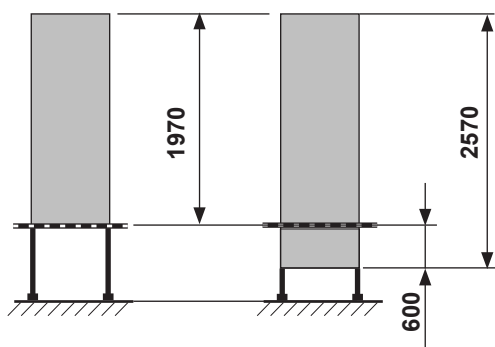

NOTE The top of an extended unit placed under a raised floor will be at the same height as the top of a standard unit placed on the floor

3 - Height of the accessories at bottom

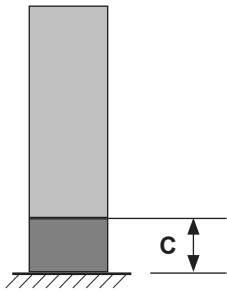

U - Upflow
H - Downflow Frontal

Base module

Height [C]:
- 200 mm

Base module H 600/300 mm with rear air intake

Height [C]:
- 600 mm for rear/bottom air intake
- 300 mm for bottom air intake

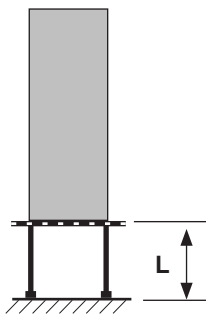

D - Downflow Up
E - Downflow Down

Legs kit

The height [L] is adjustable within the following ranges:
- 30–370 mm
- 370–570 mm
- 570–800 mm

Base frame

The height [L] is adjustable within the following range:
- 120–800 mm

4 - Height of the accessories on top

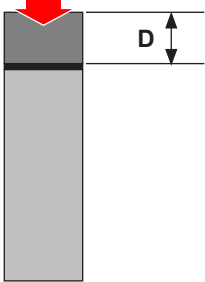

H - Downflow Frontal
D - Downflow Up
E - Downflow Down

Accessory on top of the unit

Height [D]: see the table below.

| Accessory | Height D [mm] |
|--------------------------------------|-----------------------------|
| Vertical flow extension hood | 500 - 600 - 700 - 800 - 900 |
| Hood with high efficiency air filter | 600 - 900 |
| Plenum with silencing cartridges | 600 - 900 |
| Horizontal hood with grid | 600 |
| Air economizer | 850 |

5 - Free space from the floor

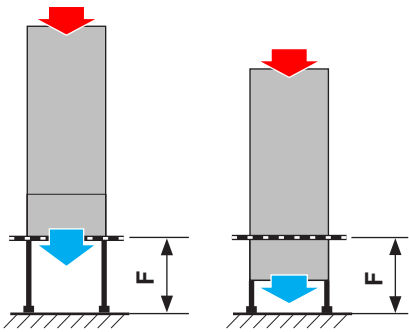

D - Downflow Up
E - Downflow Down

Free space [F] between the bottom of the unit and the floor

- Maximum: 800 mm, which is the maximum available height for the base frame or legs kit (see above).
- Minimum to obtain the declared performances: 600 mm
- Minimum allowable to obtain the minimum working conditions: 300 mm

PW400

1200 mm Minimum height to obtain the declared performances in case the unit is installed close to the wall

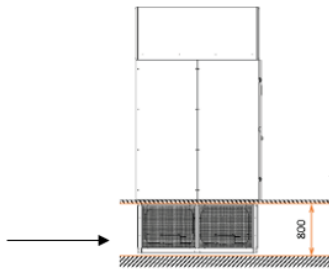

Minimum height to obtain the declared performances with 800mm from the back of the unit and the wall.

6 - Free space from the ceiling

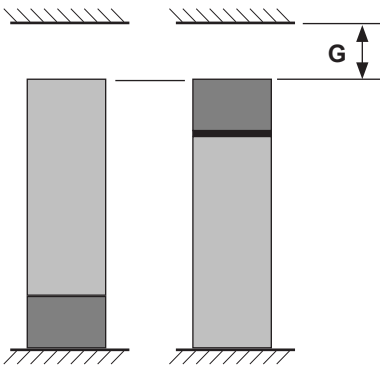

H - Downflow Frontal
D - Downflow Up
E - Downflow Down

Free space [G] between the ceiling and the unit top, including any accessory mounted on top or bottom

- Minimum to obtain the declared performances: 600 mm
- Minimum allowable to obtain the minimum working conditions: 300 mm

7 - Hole in the floor for Downflow Up units

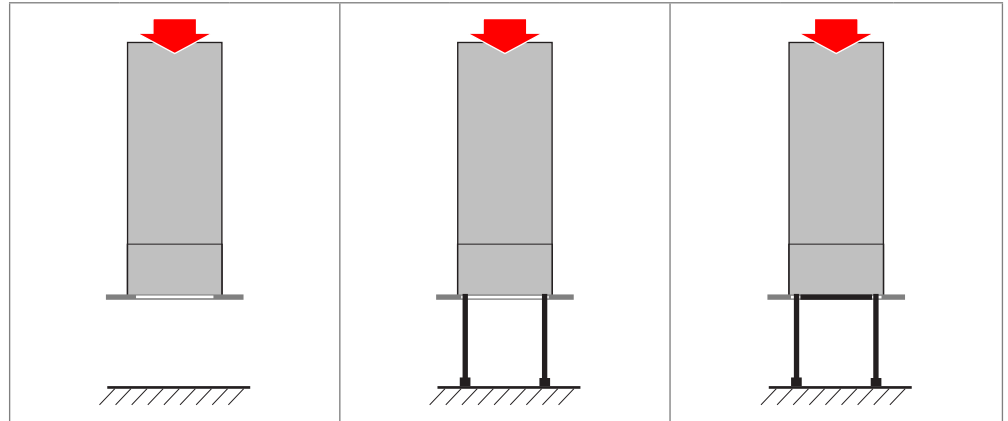
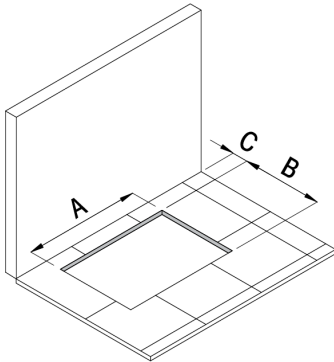



| Frame type | No accessories for support | | | With legs kit | | | With base frame | | |
|------------|----------------------------|--------|--------|---------------|--------|--------|-----------------|--------|--------|
| | A [mm] | B [mm] | C [mm] | A [mm] | B [mm] | C [mm] | A [mm] | B [mm] | C [mm] |
| 1 | 740 | 760 | 70 | Not available | | | 804 | 830 | 30 |
| 2 | 1 100 | 760 | 70 | 1 156 | 820 | 30 | 1 176 | 840 | 30 |
| 3 | 1 650 | 760 | 70 | 1 706 | 820 | 30 | 1 726 | 840 | 30 |
| 4 | 1 950 | 760 | 70 | 2 006 | 820 | 30 | 2 026 | 840 | 30 |
| 5 | 2 450 | 760 | 70 | 2 506 | 820 | 30 | 2 526 | 840 | 30 |
| 6 | 2 850 | 760 | 70 | 2 906 | 820 | 30 | 2 926 | 840 | 30 |
| 7 | 3 250 | 760 | 70 | 3 306 | 820 | 30 | 3 326 | 840 | 30 |

NOTE [C] is the minimum free space between the unit at its final position and any back wall or obstacle. You might need more space for assembly or installation operations. In that case, do the assembly or installation operation nearby and then place the unit at the final position.

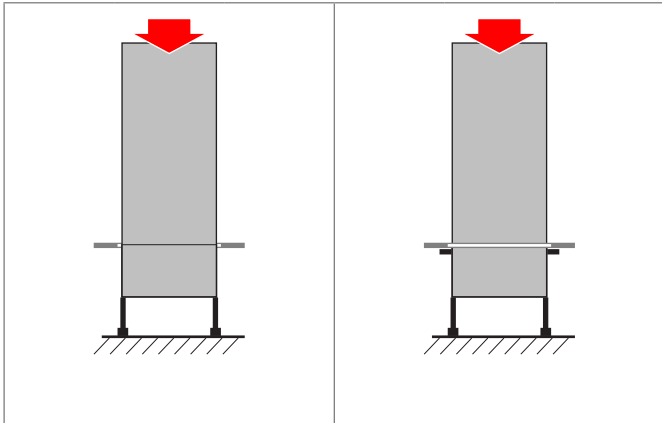
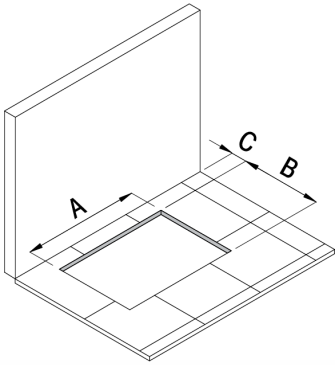
8 - Hole in the floor for Downflow Down units

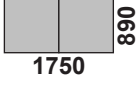
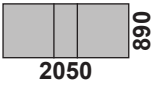
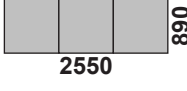
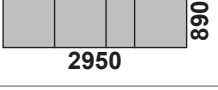
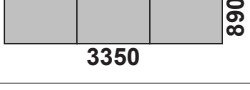
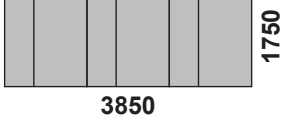

| Frame type | No accessories for support | | | With floor tiles support kit | | |
|--|----------------------------|--------|--------|------------------------------|--------|--------|
| | A [mm] | B [mm] | C [mm] | A [mm] | B [mm] | C [mm] |
| 1  | Not available | | | Not available | | |
| 2  | 1 182 | 846 | 20 | 1 220 | 885 | 50 |
| 3  | 1 732 | 846 | 20 | 1 770 | 885 | 50 |
| 4  | 2 032 | 846 | 20 | 2 070 | 885 | 50 |
| 5  | 2 532 | 846 | 20 | 2 570 | 885 | 50 |
| 6  | 2 932 | 846 | 20 | 2 970 | 885 | 50 |
| 7  | 3 332 | 846 | 20 | 3 370 | 885 | 50 |
| 11  | 3832 | 1710 | 20 | | | |

NOTE [C] is the minimum free space between the unit at its final position and any back wall or obstacle. You might need more space for assembly or installation operations. In that case, do the assembly or installation operation nearby and then place the unit at the final position.

9 - Weights

Table 04 - Unit weight

| MODEL | Single circuit unit [kg] | Double circuit unit [kg] | Packaging | | |
|---|--------------------------|--------------------------|-----------------|-------------------|------------------|
| | | | "Standard [kg]" | "Wood Crate [kg]" | "Seaworthy [kg]" |
| Standrad Height unit | | | | | |
| PW025 | 329 | - | 19 | 55 | 130 |
| PW030 | 339 | - | 19 | 55 | 130 |
| PW035 | 379 | - | 23 | 60 | 150 |
| PW040 | 396 | 419 | 23 | 60 | 150 |
| PW045 | 509 | - | 28 | 65 | 180 |
| PW060 | 539 | 552 | 28 | 65 | 180 |
| PW070 | 613 | - | 31 | 70 | 200 |
| PW080 | 629 | 649 | 31 | 70 | 200 |
| PW095 | 752 | - | 42 | 75 | 235 |
| PW110 | 782 | 795 | 42 | 75 | 235 |
| PW145 | 866 | 879 | 47 | 78 | 250 |
| PW170 | 1005 | 1080 | 58 | 80 | 290 |
| Extended Height unit [Coil Module] ⁽¹⁾ | | | | | |
| PW046 | 299 | 326 | 23 | 60 | 150 |
| PW066 | 439 | 483 | 28 | 65 | 180 |
| PW091 | 502 | 531 | 31 | 70 | 200 |
| PW136 | 617 | 640 | 42 | 75 | 235 |
| PW161 | 707 | 720 | 47 | 78 | 250 |
| PW201 | 720 | 733 | 58 | 80 | 290 |
| Extended Height unit [Fan Base Frame] ⁽¹⁾ | | | | | |
| BFW12 | 91 | | 26 | 60 | 125 |
| BFW17 | 150 | | 35 | 70 | 135 |
| BFW20 | 170 | | 41 | 75 | 150 |
| BFW25 | 218 | | 54 | 88 | 170 |
| BFW29 | 245 | | 61 | 95 | 185 |
| BFW33 | 305 | | 78 | 105 | 200 |
| Extended Height unit [Fan Base Module/Fan Top Plenum] ⁽¹⁾ | | | | | |
| BMW/ TPW 12 | 132 | | 26 | 60 | 125 |
| BMW/ TPW 17 | 215 | | 35 | 70 | 135 |
| BMW/ TPW 20 | 230 | | 41 | 75 | 150 |
| BMW/ TPW 25 | 286 | | 54 | 88 | 170 |
| BMW 29 | 340 | | 61 | 95 | 185 |
| BMW 33 | 390 | | 78 | 105 | 200 |

(1) For Extended Height version, the total unit weight must be calculated by adding the Coil Module weight and Fan Section weight

NOTE: The listed Coil Module weight and Fan Section weight is the maximum weight including all additional options.

Table 05 -

| MODEL | Single circuit unit [kg] | Packaging | | |
|--|--------------------------|-----------------|-------------------|------------------|
| | | "Standard [kg]" | "Wood Crate [kg]" | "Seaworthy [kg]" |
| Extended Height unit [Coil Module] | | | | |
| PW400 | 1240 | 116 | 160 | 580 |
| Extended Height unit [Fan Base Frame] | | | | |
| BFW38 | 650 | 156 | 210 | 400 |
| Extended Height unit [Filter Top section] | | | | |
| PW400 | 650 | 156 | 210 | 400 |

10 - Packaging

Panel level packaging and pallet

Units are packed before shipping (two separate packages for coil and fan sections on Extended units). They stand on an ISPM15 fumigated wooden pallet. Standard packaging consists of honeycomb cardboard corners protecting the corners of the units, lateral walls protected by honeycomb sheets and top part of the unit covered by corrugated cardboard lid. Around the entire unit, including the cardboards, a polyethylene stretch film is applied.

Panel level packaging and wooden crate

The standard cardboard packing is enclosed by additional wooden crate.



NOTICE

Add +150 mm to the total packaging height for standard and wooden crate packaging if the unit is equipped with damper

Seaworthy packaging

In addition to the standard cardboard packing the packing contains desiccant bags, the whole unit is wrapped in VCI foil and enclosed within a seaworthy wooden box.

Fig.11.c - Packing of unit

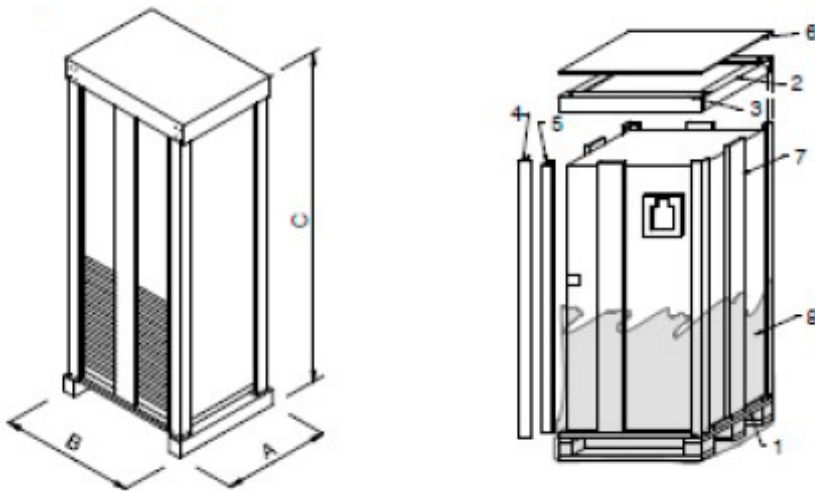
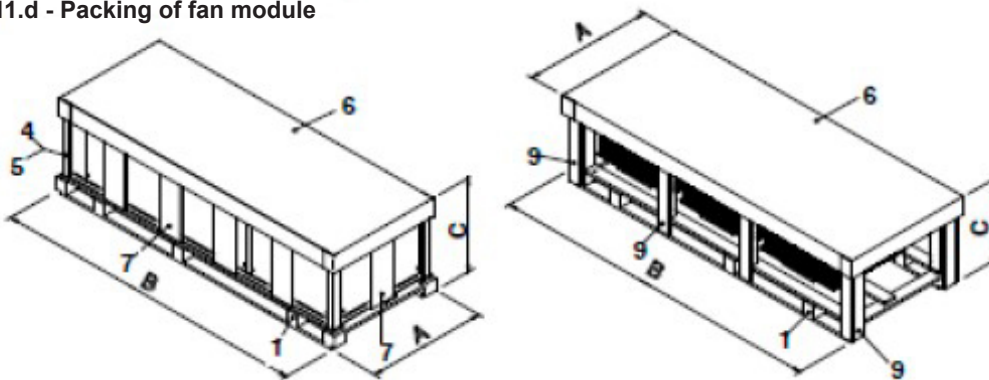
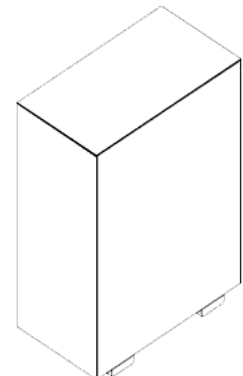
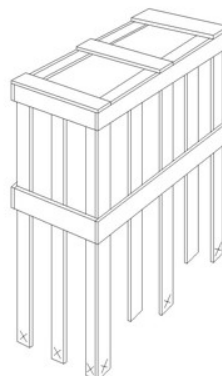
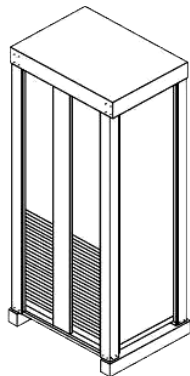

Fig.11.d - Packing of fan module



| Liebert® PCW Model | Standard Packaging | | | Wooden Crate | | | Seaworthy | | |
|--------------------|--------------------|--------|--------|--------------|--------|--------|-----------|--------|--------|
| | W (mm) | D (mm) | H (mm) | W (mm) | D (mm) | H (mm) | W (mm) | D (mm) | H (mm) |
| CW Units | | | | | | | | | |
| PW025 | 924 | 960 | 2140 | 1026 | 1062 | 2220 | 1021 | 1056 | 2345 |
| PW030 | 924 | 960 | 2140 | 1026 | 1062 | 2220 | 1021 | 1056 | 2345 |
| PW035 | 1280 | 960 | 2140 | 1382 | 1062 | 2220 | 1376 | 1056 | 2345 |
| PW040 | 1280 | 960 | 2140 | 1382 | 1062 | 2220 | 1376 | 1056 | 2345 |
| PW045 | 1830 | 960 | 2140 | 1932 | 1062 | 2220 | 1926 | 1056 | 2345 |
| PW060 | 1830 | 960 | 2140 | 1932 | 1062 | 2220 | 1926 | 1056 | 2345 |
| PW070 | 2130 | 960 | 2140 | 2232 | 1062 | 2220 | 2226 | 1056 | 2345 |
| PW080 | 2130 | 960 | 2140 | 2232 | 1062 | 2220 | 2226 | 1056 | 2345 |
| PW095 | 2630 | 960 | 2140 | 2732 | 1062 | 2220 | 2726 | 1056 | 2345 |
| PW110 | 2630 | 960 | 2140 | 2732 | 1062 | 2220 | 2726 | 1056 | 2345 |
| PW145 | 3030 | 960 | 2140 | 3132 | 1062 | 2220 | 3126 | 1056 | 2345 |
| PW170 | 3430 | 960 | 2140 | 3532 | 1062 | 2220 | 3526 | 1056 | 2345 |
| PW046 | 1280 | 960 | 2140 | 1382 | 1062 | 2220 | 1376 | 1056 | 2420 |
| PW066 | 1830 | 960 | 2140 | 1932 | 1062 | 2220 | 1926 | 1056 | 2420 |
| PW091 | 2130 | 960 | 2140 | 2232 | 1062 | 2220 | 2226 | 1056 | 2420 |
| PW136 | 2630 | 960 | 2140 | 2732 | 1062 | 2220 | 2726 | 1056 | 2420 |
| PW161 | 3030 | 960 | 2140 | 3132 | 1062 | 2220 | 3126 | 1056 | 2420 |
| PW201 | 3430 | 960 | 2140 | 3532 | 1062 | 2220 | 3526 | 1056 | 2420 |
| PW400 | 3940 | 1834 | 2195 | 4032 | 1926 | 2218 | 4026 | 2004 | 2290 |
| BFW12 | 1280 | 960 | 800 | 1382 | 1062 | 850 | 1376 | 1056 | 1035 |
| BFW17 | 1830 | 960 | 800 | 1932 | 1062 | 850 | 1926 | 1056 | 1035 |
| BFW20 | 2130 | 960 | 800 | 2232 | 1062 | 850 | 2226 | 1056 | 1035 |
| BFW25 | 2630 | 960 | 800 | 2732 | 1062 | 850 | 2726 | 1056 | 1035 |
| BFW29 | 3030 | 960 | 800 | 3132 | 1062 | 850 | 3126 | 1056 | 1035 |
| BFW33 | 3430 | 960 | 800 | 3532 | 1062 | 850 | 3526 | 1056 | 1035 |
| BFW38 | 3940 | 1834 | 900 | 4032 | 1926 | 923 | 4026 | 2004 | 990 |
| BMW12/TPW12 | 1280 | 960 | 800 | 1382 | 1062 | 850 | 1376 | 1056 | 1035 |
| BMW17/TPW17 | 1830 | 960 | 800 | 1932 | 1062 | 850 | 1926 | 1056 | 1035 |
| BMW20/TPW20 | 2130 | 960 | 800 | 2232 | 1062 | 850 | 2226 | 1056 | 1035 |
| BMW25/TPW25 | 2630 | 960 | 800 | 2732 | 1062 | 850 | 2726 | 1056 | 1035 |
| BMW29 | 3030 | 960 | 800 | 3132 | 1062 | 850 | 3126 | 1056 | 1035 |
| BMW33 | 3430 | 960 | 800 | 3532 | 1062 | 850 | 3526 | 1056 | 1035 |



Annex C - Hydraulic and Electrical Connections

Content

- 1 - Hydraulic and electrical connections - Downflow versions...70
- 2 - Hydraulic and electrical connections - Upflow versions..71

Tab. 1 - Hydraulic and electrical connections – Downflow versions

| Unit Connection | | PW025 PW030 | PW035 PW040 PW046 | PW045 PW060 PW066 | PW070 PW080 PW091 | PW095 PW110 PW136 | PW145 PW161 | PW170 PW201 | Height from unit bottom |
|-----------------|--|---|-------------------------|-------------------------|----------------------------------|------------------------------------|------------------------------------|------------------------------------|----------------------------------|
| ICW | Chilled water inlet (single chilled water circuit) | Rp 1 ¼ ISO 7/1 | Rp 1 ¼ ISO 7/1 | Rp 1 ½ ISO 7/1 | O.D. Ø54 mm** R 2 - ISO7/1*** | O.D. Ø64 mm** R 2½ ISO7/1*** | O.D. Ø64 mm** R 2½ ISO7/1*** | O.D. Ø64 mm** R 2½ ISO7/1*** | 394 |
| OCW | Chilled water ou- tlet (single chilled water circuit) | Rp 1 ¼ ISO 7/1 | Rp 1 ¼ ISO 7/1 | Rp 1 ½ ISO 7/1 | O.D. Ø54 mm** R 2 - ISO7/1*** | O.D. Ø64 mm** R 2½ ISO7/1*** | O.D. Ø64 mm** R 2½ ISO7/1*** | O.D. Ø64 mm** R 2½ ISO7/1*** | 344 |
| ICW1 | Chilled water inlet 1 (double chilled water circuit) | NA | Rp 1 ¼ ISO 7/1 | Rp 1 ½ ISO 7/1 | Rp 1 ½ ISO 7/1 | O.D. Ø54 mm** R 2 - ISO7/1*** | O.D. Ø54 mm** R 2 - ISO7/1*** | O.D. Ø54 mm** R 2 - ISO7/1*** | 394 |
| OCW 1 | Chilled water ou- tlet 1 (double chilled water circuit) | NA | Rp 1 ¼ ISO 7/1 | Rp 1 ½ ISO 7/1 | Rp 1 ½ ISO 7/1 | O.D. Ø54 mm** R 2 - ISO7/1*** | O.D. Ø54 mm** R 2 - ISO7/1*** | O.D. Ø54 mm** R 2 - ISO7/1*** | 344 |
| ICW2 | Chilled water inlet 2 (double chilled water circuit) | NA | Rp 1 ¼ ISO 7/1 | Rp 1 ½ ISO 7/1 | Rp 1 ½ ISO 7/1 | O.D. Ø54 mm** R 2 - ISO7/1*** | O.D. Ø54 mm** R 2 ISO7/1*** | O.D. Ø54 mm** R 2 - ISO7/1*** | 394 |
| OCW 2 | Chilled water ou- tlet 2 (double chilled water circuit) | NA | Rp 1 ¼ ISO 7/1 | Rp 1 ½ ISO 7/1 | Rp 1 ½ ISO 7/1 | O.D. Ø54 mm** R 2 - ISO7/1*** | O.D. Ø54 mm** R 2 - ISO7/1*** | O.D. Ø54 mm** R 2 - ISO7/1*** | 344 |
| CD | Condensate drain | I.D. Ø20 [mm] | | | | | | | - |
| CD* | Condensate drain | I.D. Ø20 [mm] | | | | | | | - |
| HF | Humidifier feed | R ½ - ISO 7/1 (Electrode Humidifier), O.D. 6 [mm] (Infrared Humidifier) | | | | | | | - |
| HD | Humidifier drain | I.D. Ø32 [mm] (Electrode Humidifier), I.D. Ø22 [mm] (Infrared Humidifier) | | | | | | | - |
| EC | Electrical power supply | Ø 48 [mm] | | | | | | | - |
| EC aux | Low voltage cables | Ø 40 - Ø 36 [mm] | | | | | | | - |

CD* only for unit from PW095 to PW201

** Grooved Connection.

*** Optional. Threaded union on request

NA = Not Available

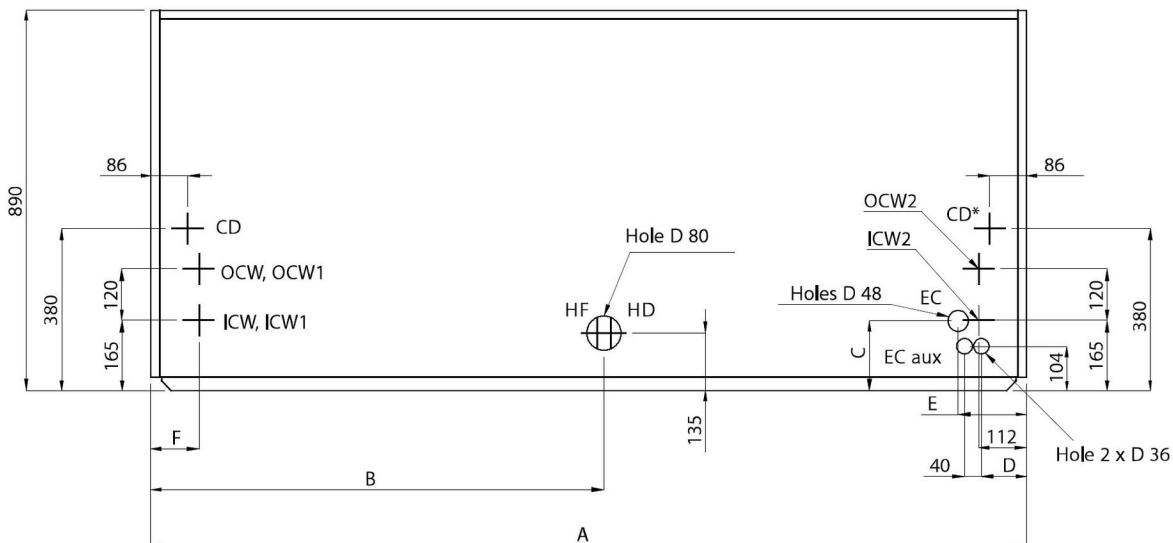

Tab. 2 - Downflow units, dimensions for Bottom, Top & Piping left Option

| Unit Connection | PW025 PW030 | PW035 PW040 PW046 | PW045 PW060 PW066 | PW070 PW080 PW091 | PW095 PW100 PW136 | PW145 PW161 | PW170 PW201 |
|--|----------------|-------------------------|-------------------------|-------------------------|-------------------------|----------------|----------------|
| Dimensions for Piping Bottom Option (Fig. 1.) | | | | | | | |
| A | 844 | 1200 | 1750 | 2050 | 2550 | 2950 | 3350 |
| B | 95 | 235 | 910 | 1060 | 1565 | 1855 | 2385 |
| C | 125 | 160 | 160 | 160 | 150 | 150 | 150 |
| D | 140 | 105 | 105 | 105 | 150 | 150 | 150 |
| E | 100 | 120 | 120 | 120 | 115 | 115 | 115 |
| F | 76 | 112 | 112 | 112 | 112 | 112 | 112 |
| Dimensions for Piping Top & Piping left Option (Fig. 2.) | | | | | | | |
| G | 115 | 115 | 190 | 185 | 170 | 170 | 170 |
| H | NA | 135 | 135 | 135 | 120 | 120 | 120 |

NA = Not Available

Fig. 2. Downflow units, dimensions for Top & Piping left Option

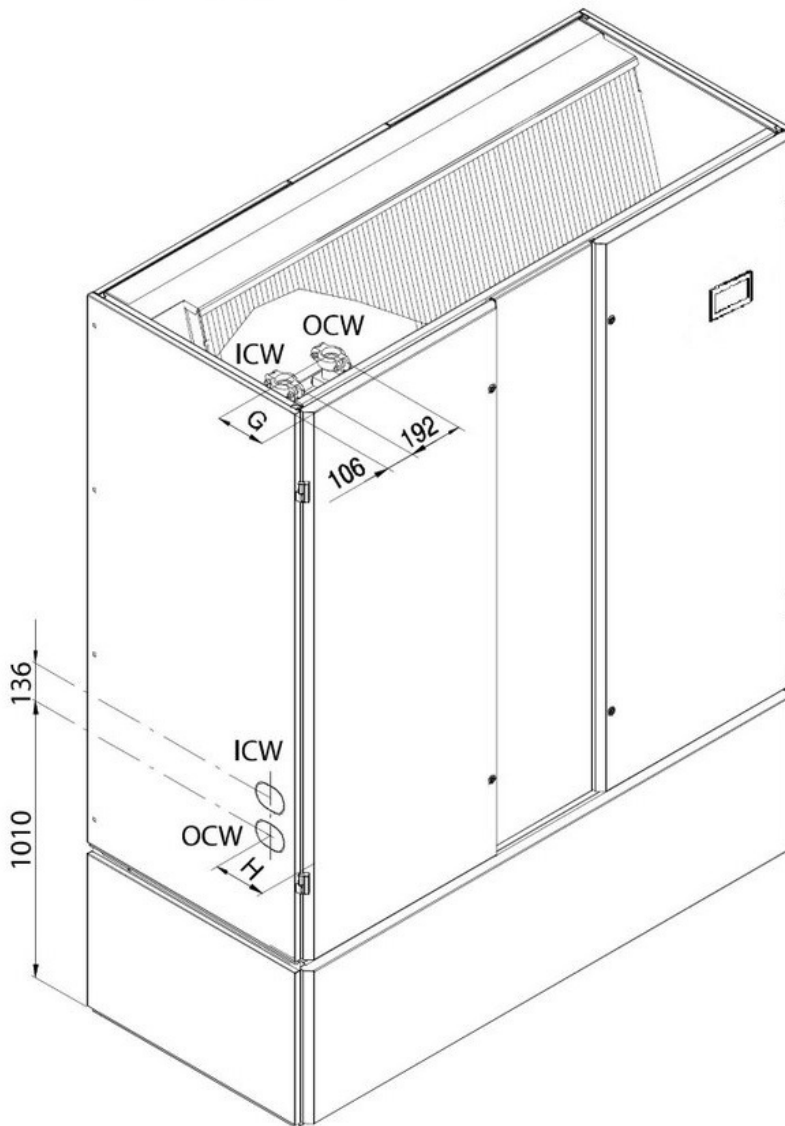

Tab. 3 - Hydraulic and electrical connections – Upflow versions

| Unit Connection | | PW025 PW030 | PW035 PW040 PW046 | PW045 PW060 PW066 | PW070 PW080 PW091 | PW095 PW110 | Height from unit bottom [mm] |
|-----------------|-------------------------|---|-------------------------|-------------------------|----------------------------------|------------------------------------|------------------------------------|
| ICW | Chilled water inlet | Rp 1 ¼ - ISO 7/1 | Rp 1 ¼ - ISO 7/1 | Rp 1 ½ - ISO 7/1 | O.D. Ø54 mm ** R 2- ISO7/1*** | O.D. Ø64 mm ** R21/2 –ISO7/1*** | 334 |
| OCW | Chilled water outlet | Rp 1 ¼ - ISO 7/1 | Rp 1 ¼ - ISO 7/1 | Rp 1 ½ - ISO 7/1 | O.D. Ø54 mm ** R 2- ISO7/1*** | O.D. Ø64 mm ** R21/2 –ISO7/1*** | 285 |
| CD | Condensate drain | I.D. Ø20 [mm] | | | | | - |
| CD* | Condensate drain | I.D. Ø20 [mm] | | | | | - |
| HF | Humidifier feed | R ½ - ISO 7/1 (Electrode Humidifier), O.D. 6 [mm] (Infrared Humidifier) | | | | | - |
| HD | Humidifier drain | I.D. Ø32 [mm] (Electrode Humidifier), I.D. Ø22 [mm] (Infrared Humidifier) | | | | | - |
| EC | Electrical power supply | Ø 48 [mm] | | | | | - |
| EC aux | Low voltage cables | Ø 40 - Ø 36 [mm] | | | | | - |

CD* only for unit from PW095 to PW110

** Grooved Connection.

*** Optional. Threaded union on request

Tab. 3 - Hydraulic and electrical connections – Upflow versions

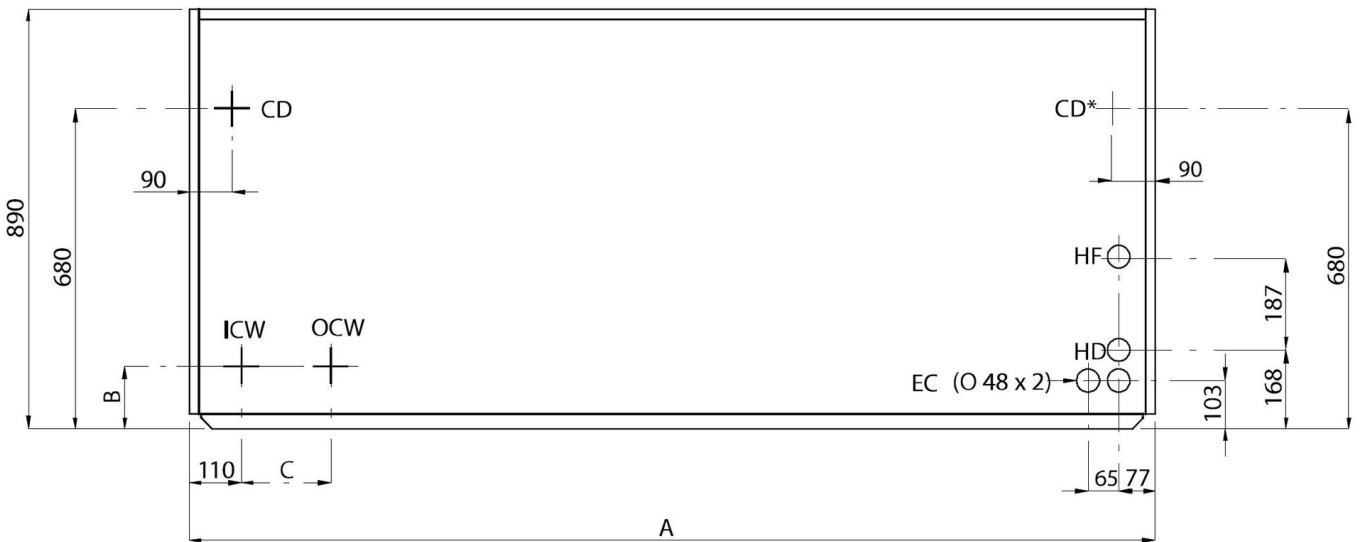

Tab. 4 - Upflow unit, Dimensions for Piping Bottom, Top & Piping left Option

| Unit Connection | PW025 PW030 | PW035 PW040 PW046 | PW045 PW060 PW066 | PW070 PW080 PW091 | PW095 PW110 |
|--|----------------|----------------------|----------------------|----------------------|----------------|
| Dimensions for Piping Bottom Option (Fig. 3.) | | | | | |
| A | 844 | 1200 | 1750 | 2050 | 2550 |
| B | 130 | 135 | 135 | 135 | 135 |
| C | 90 | 190 | 190 | 190 | 190 |
| Dimensions for Piping Top & Piping left Option (Fig. 4.) | | | | | |
| D | NA | 135 | 135 | 120 | 120 |

NA = Not Available

Fig. 4. Upflow unit, Dimensions for Piping Top & Piping left Option

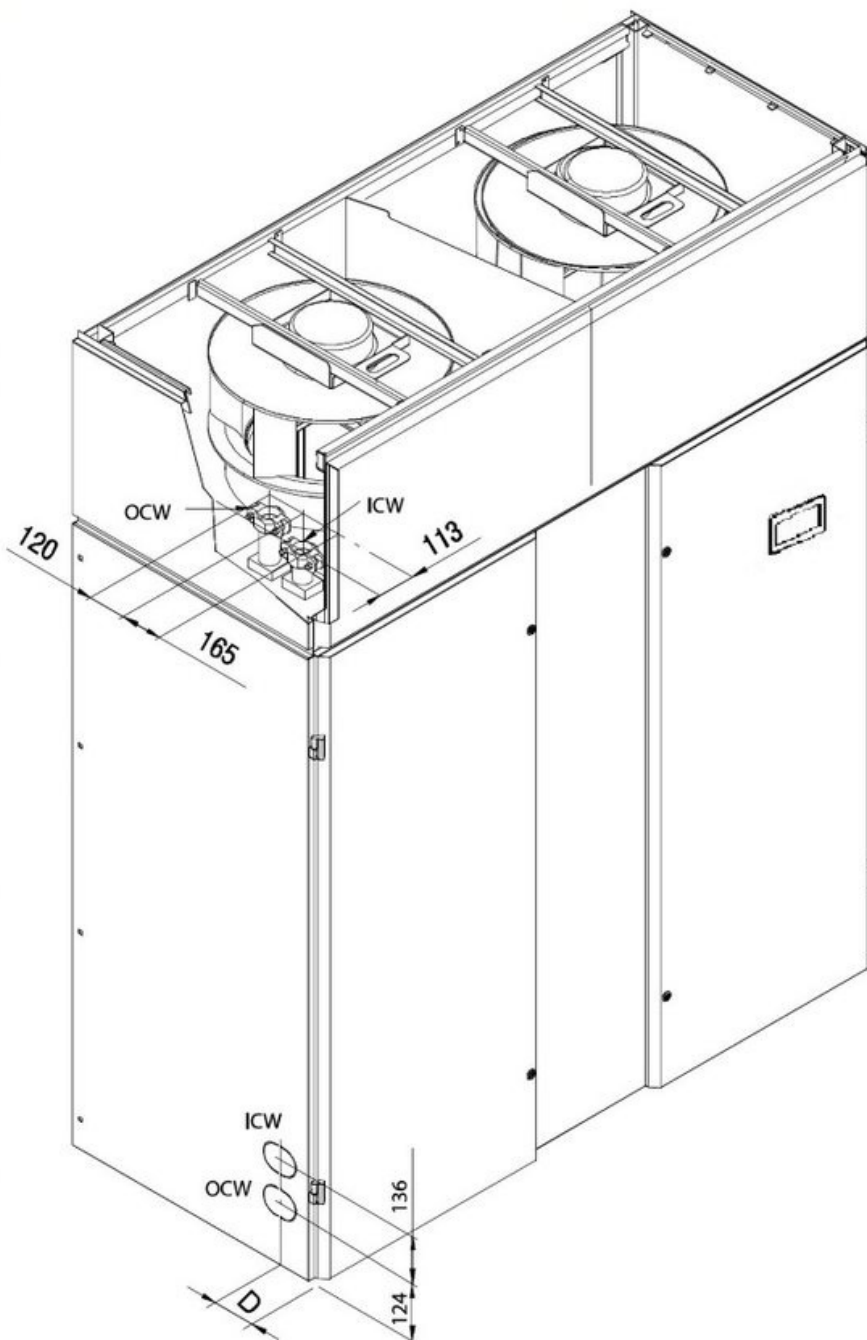

Liebert® PCW 400

Key to symbols

| Symbol | Description |
|--------|-----------------------------|
| ICW | Chilled water INLET |
| OCW | Chilled water OUTLET |
| EC | Electrical power supply |
| EC aux | Low voltage cables |
| CD | Condensate Drain |

Hydraulic and electrical connections

| Point | Description | Connection size [mm] PW400 |
|--------|---------------------------------|-------------------------------|
| ICW | Chilled water INLET | O.D. Ø 88,9 mm |
| OCW | Chilled water OUTLET | O.D. Ø 88,9 mm |
| CD | Condensate drain | 4 x I.D. Ø 20 mm |
| EC | Electrical power supply | Ø 80,5 mm |
| EC aux | Low voltage cables | 2 x Ø 48 mm |
| FC | Free cutout | Ø 48 mm |
| CEC | Customer low voltage connection | Ø 48 mm |

Dimensions for piping – Bottom connection (Top view)

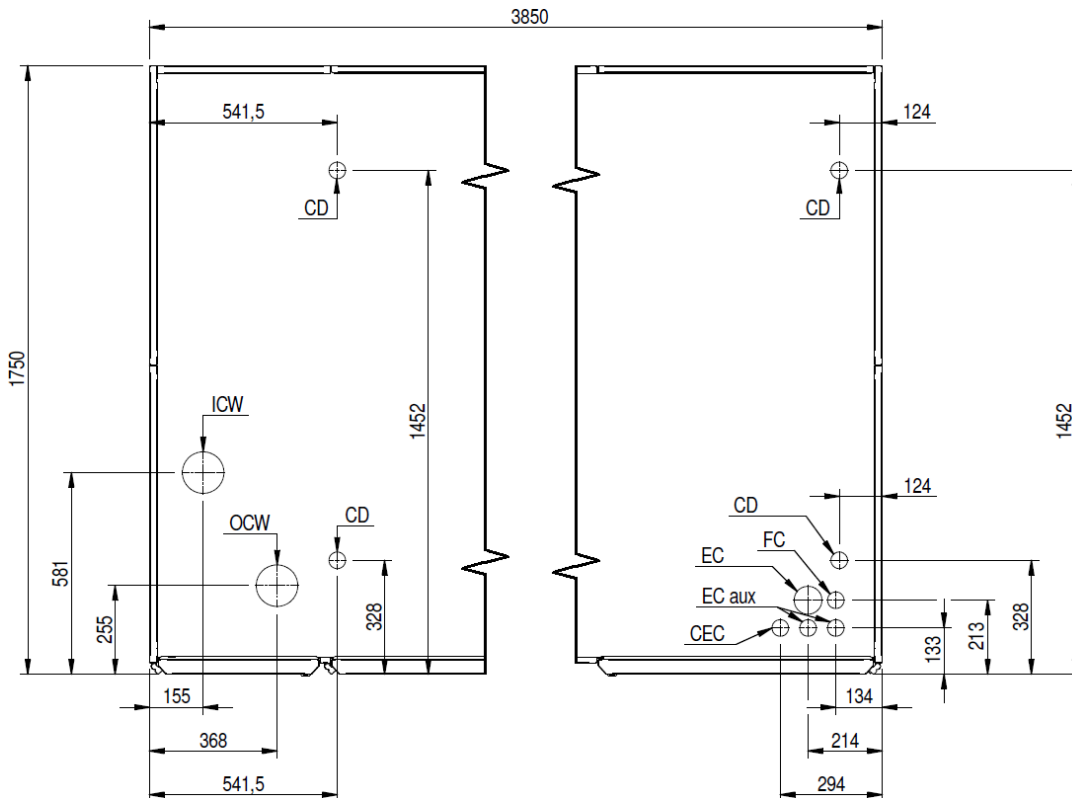

External CW piping connections
Bottom connection

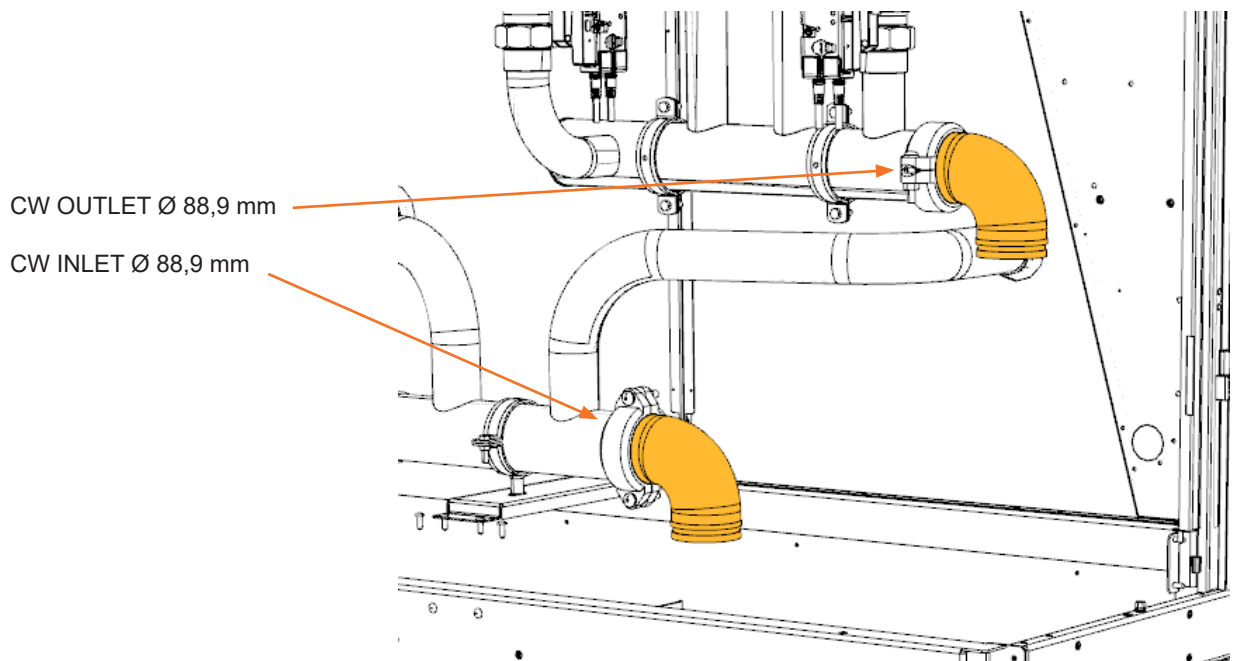
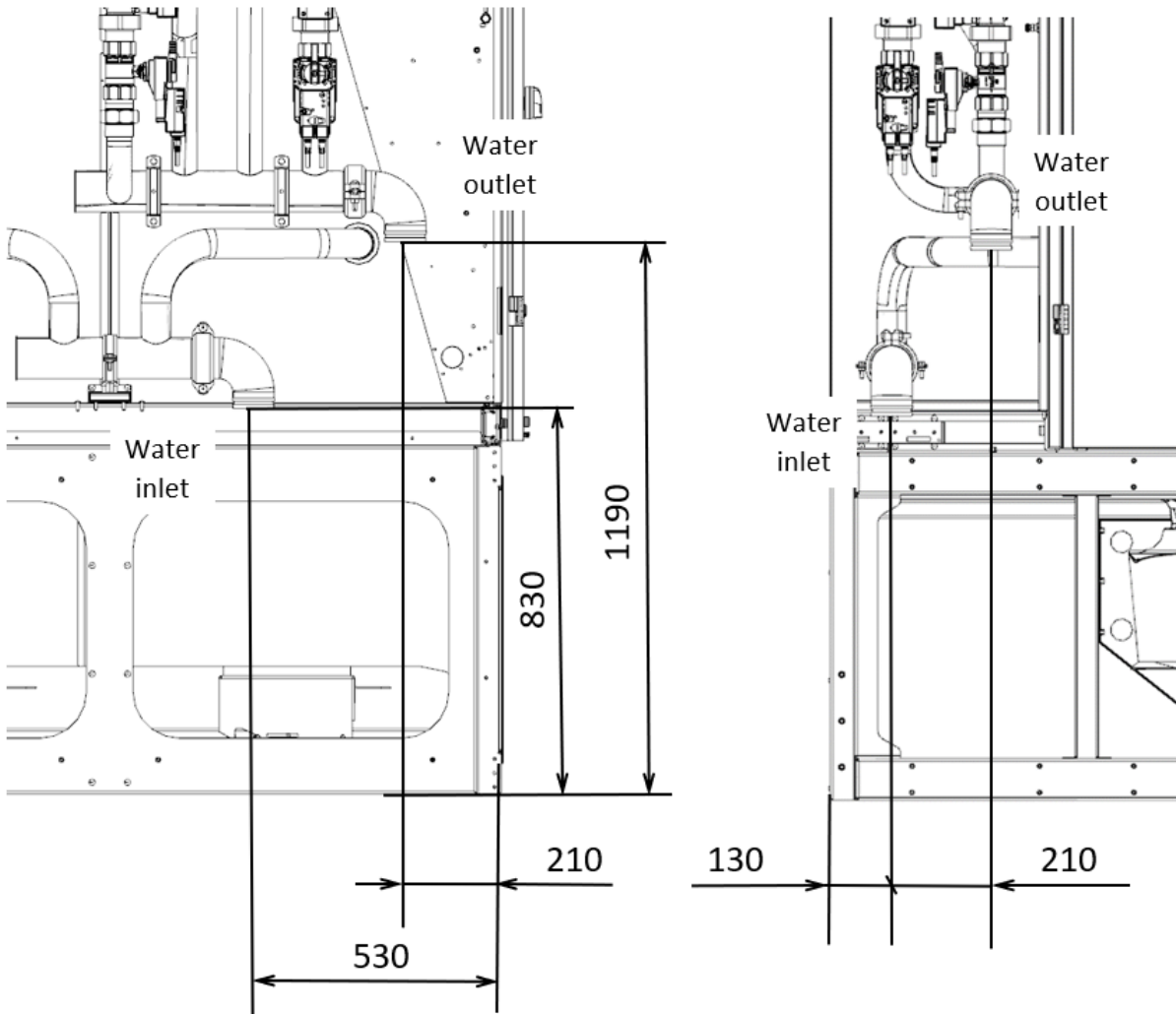

Lateral connection

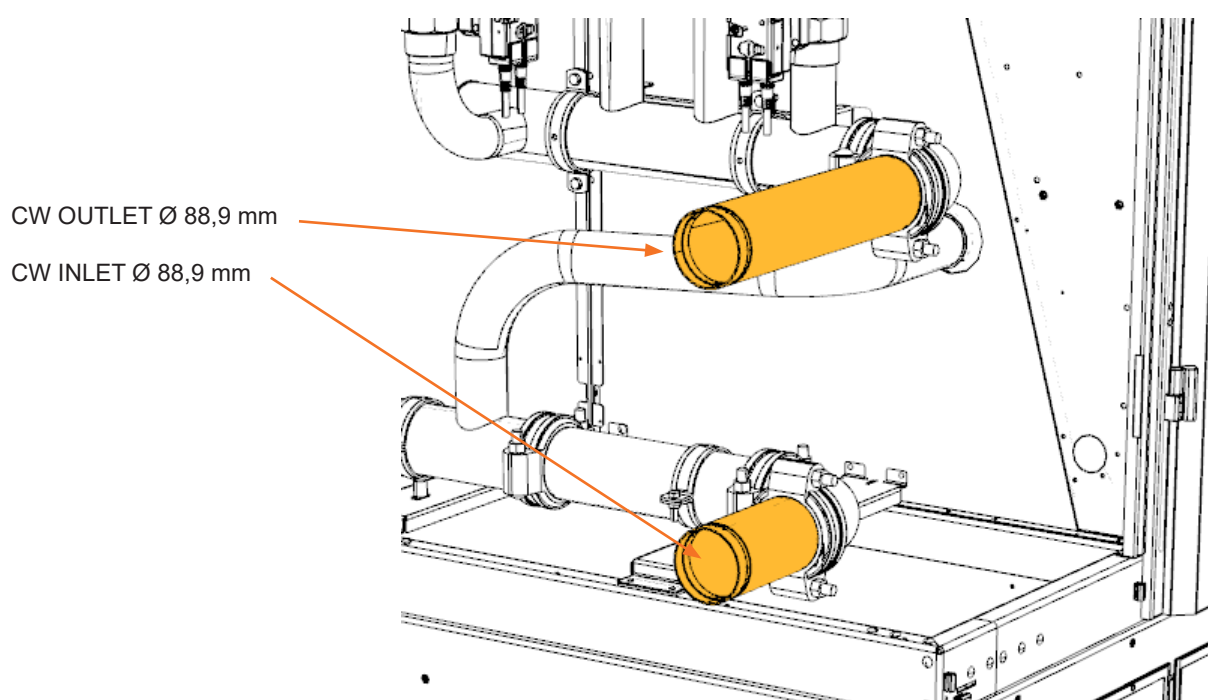
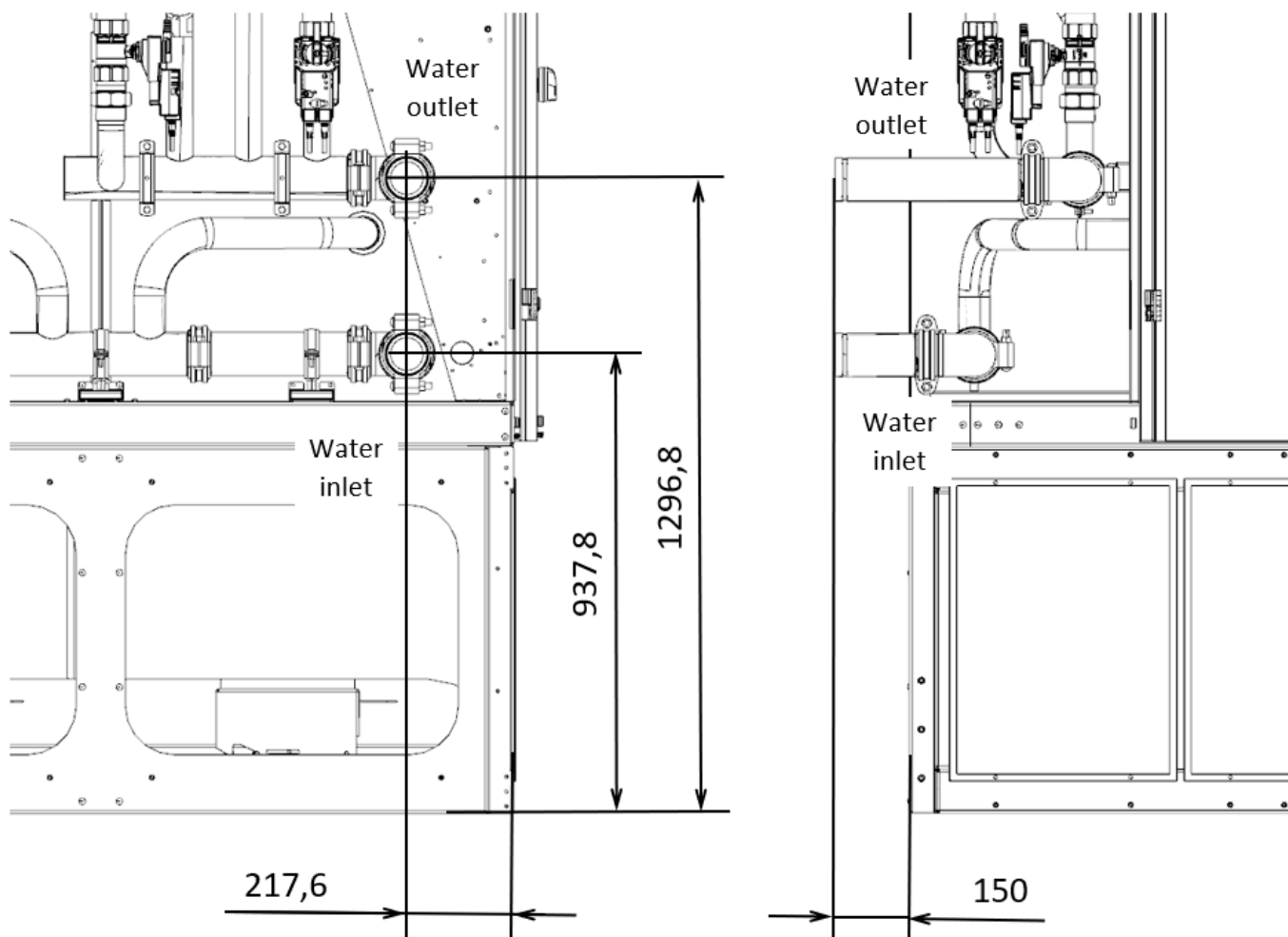

Top connection

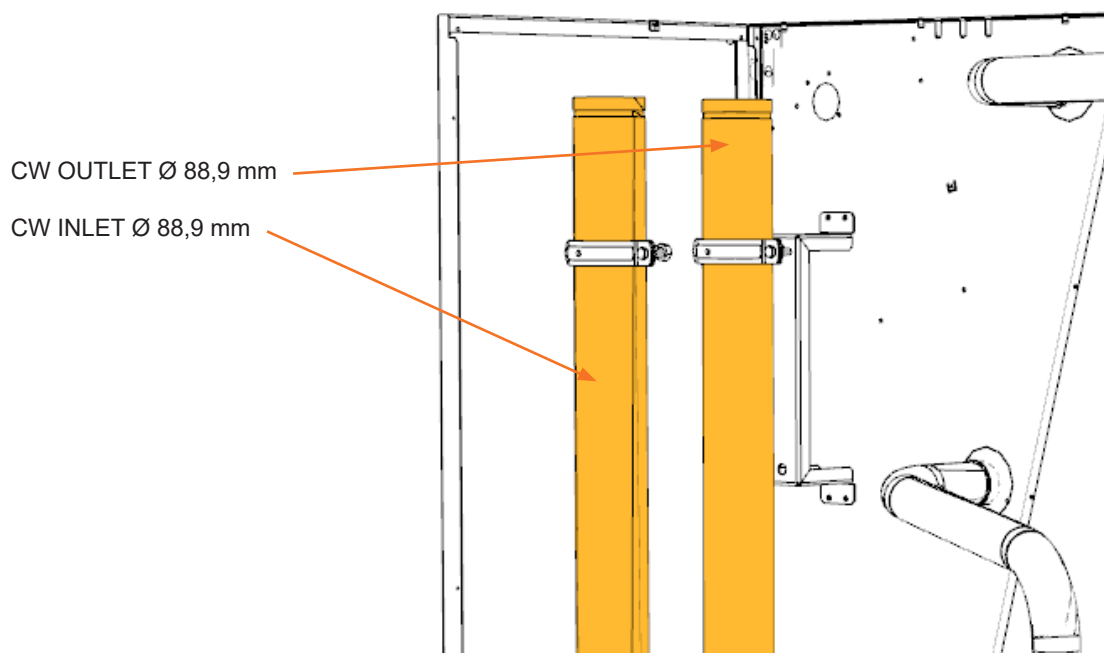
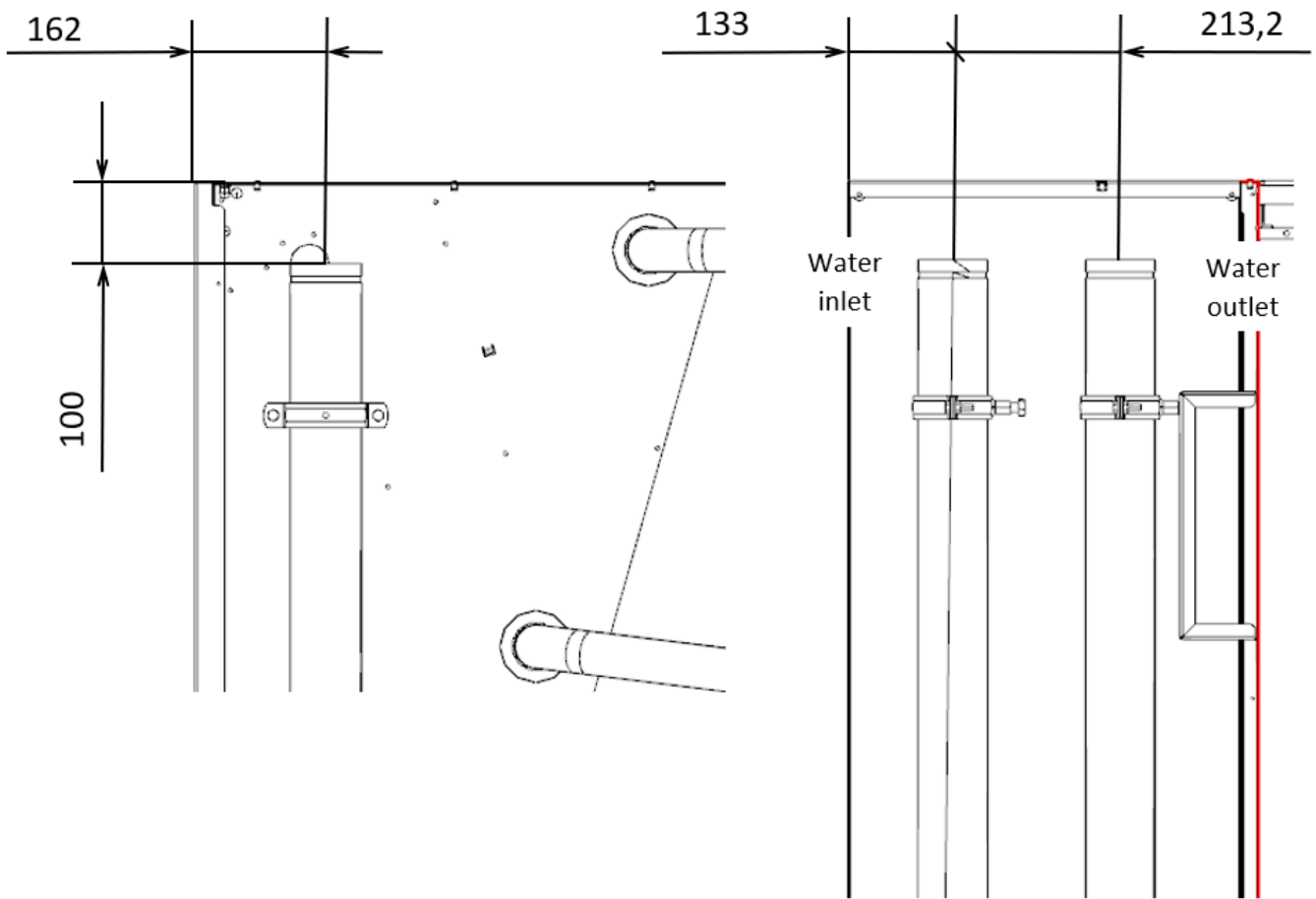

Annex D - Additional Options

Content

| | | | |
|-------------------------------------|----|---|----|
| 1 - Overpressure damper..... | 75 | 6 - Pressure control..... | 76 |
| 2 - Motorized damper..... | 75 | 7 - Ethernet switch..... | 76 |
| 3 - Spring return damper..... | 75 | 8 - Main switch on the frontal panel..... | 77 |
| 4 - Bottom Air Intake - Option..... | 76 | 9 - Phase Detector..... | 77 |
| 5 - Alarm card..... | 76 | | |

1 - Overpressure damper

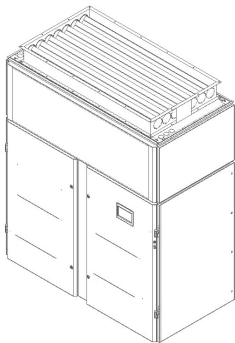

Overpressure damper fitted on the top of the unit, which closes in case of no airflow exploiting gravity effect.

2 - Motorized damper

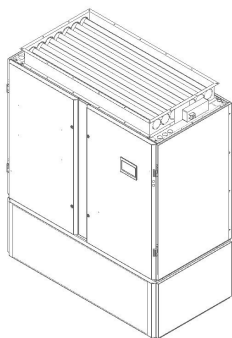

Motorized Damper with servomotor fitted on the top directly controlled by the unit. The unit controls the damper in the safest way managing fans depending on damper position.

3 - Spring return damper

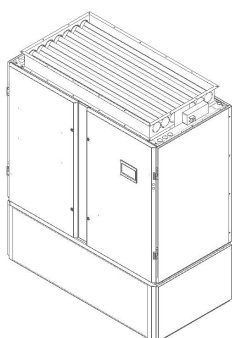

Motorized Damper with spring return servomotor fitted on the top directly controlled by the unit. The unit controls the damper in the safest way managing fans depending on damper position. In case of power failure, the spring return allows the damper to close, therefore avoiding air passing through a not working unit.

4 - Bottom Air Intake – Option

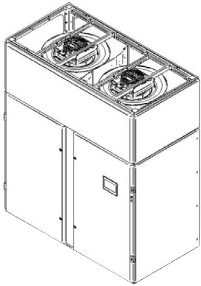

The unit is configured with the bottom part open and the frontal panel blacked in order to allow the air stream from the bottom to the top of the unit. Filter positioning doesn't need to be changed and the unit guarantee easily access from the front of it.

5 - Alarm card



The unit shall be fitted with alarm card to allow remote monitoring through electrical signals of most important alarms (up to 6), for monitoring working conditions or events (failure). The outputs (all together) can be set to N.O. (normally open) or N.C. (normally closed).

6 - Pressure control



Pressure control transducer control fan speed for keeping constant the static pressure.

In case of multiple units are connected in teamwork, they share pressure sensor data to provide greater flexibility, visibility and control. User can decide to control the fans on the average reading collected in the U2U network. In case of failure, system can work until only one sensor is available.

7 - Ethernet Switch



Ethernet Switch with 5 RJ45 ports shall be installed in the electrical panel. The device needs to include LED indicators for an easier use.

8 - Main Switch on the frontal Panel

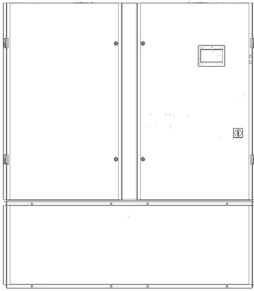

The switch shall be accessible from the front of the unit with the door closed and prevent access to the high-voltage electrical components unit switched to the off positioning. The manual disconnect switch shall be mounted in the high-voltage section of the electrical panel.

9 - Phase Detector



The device monitoring 3-phase and in case of incorrect phase sequence, total and partial phase loss.

Annex E - Additional Accessories

Content

| | | | |
|--|----|---|----|
| 1 - Smoke/Fire detector..... | 79 | 9 - Horizontal Hood Grill..... | 82 |
| 2 - Leak Detector - Liquistat..... | 79 | 10 - Air Economizer..... | 82 |
| 3 - Base Frame..... | 80 | 11 - Base Module 600/300 high with rear air intake..... | 83 |
| 4 - Legs Kit..... | 80 | 12 - Fresh Air Module..... | 83 |
| 5 - Base Modules 200 mm..... | 80 | 13 - Floor tiles support kit..... | 84 |
| 6 - Vertical flow estensiunon flood..... | 81 | 14 - Fans manteinance kit..... | 84 |
| 7 - Plenium with damper..... | 81 | 15 - System display..... | 84 |
| 8 - Plenium with display..... | 81 | | |

1 - Smoke/Fire detector



The smoke and fire detector sense the room air: in case of smoke, unit activates the smoke alarm event without any actions; instead in case of fire, unit activates the fire alarm event and shuts the unit down. Dry contacts are available for a remote customer alarm. This smoke detector is not intended to function as or replace any room smoke detection system that may be required by local or national codes.

2 - Leak detector - Liquistat

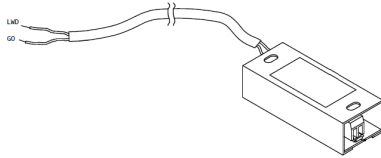

The flooding alarm detects the presence of water or of any other conductive liquid and activates an alarm. It is made up of a corrosion-proof metal covering, with access to the two terminals for connecting the line. Up to 5 sensors can be connected to the same flooding alarm device to control many points in the room.

3 - Base Frame

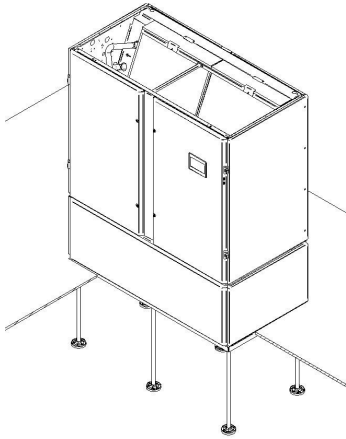

Base frame can be supplied on request to support unit when installed with a raised floor. The legs are fixed with the unit frame and allow supporting the unit at different heights, leg's height is adjustable from 120 to 800 mm, cutting them on site.

4 - Legs kit

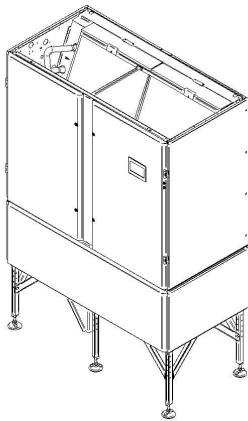

Legs kit can be supplied on request to support the unit when installed with a raised floor. The legs are fixed with the unit frame and allow supporting the unit at different heights, three kits are available with different heights, adjustable in the range:

- H1 30-370 mm;
- H2 370-570 mm;
- H3 570-800 mm.

The legs shall be designed to allow an adjustment of the height without the need of cutting or brazing any part.

5 - Base modules 200 mm

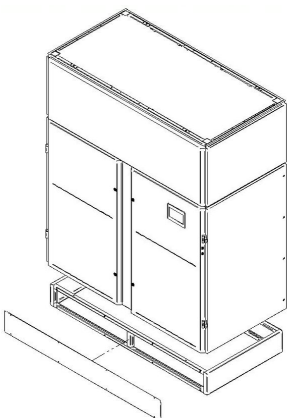

A 200 mm high base module can be supplied on request to support upflow unit or frontal air delivery configuration and at the same time allow pipe work to enter the base of the unit when a raised floor is not installed. Base module shall have the same aesthetic design as the unit.

6 - Vertical flow extension hood

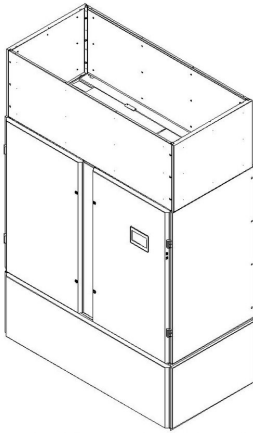

An extension hood can be supplied on request and can be installed on top of the unit. It is available with different height: 500mm; 600mm; 700mm; 800mm; 900mm. It shall be the same design as the unit and consists of sandwich panels lined with non-flammable insulation material of class A1 EU, density 20 kg/m³.

7 - Plenum with damper



A 600mm extension hood can be supplied on request and can be installed on top of the unit. A motorized damper is fitted between unit and plenum. The unit controls the damper in the safest way managing fans depending on damper position. The plenum shall be the same design as the unit and consist of sandwich panels lined with non-flammable insulation material A1 EU class, density 20 kg/m³.

8 - Plenum with display

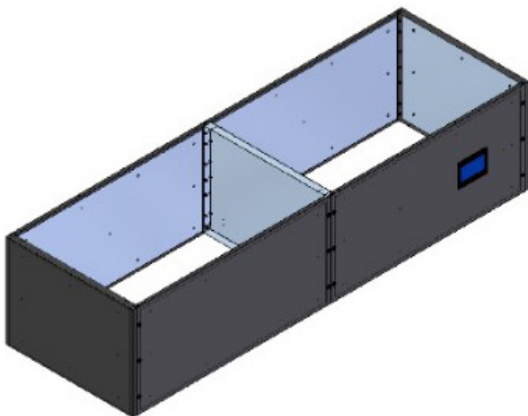

An 600mm extension hood can be supplied on request and can be installed on top of the unit.

The frontal panel should include the unit display. The plenum shall be the same design as the unit and consist of sandwich panels lined with non-flammable insulation material A1 EU class, density 20 kg/m³.

9 - Horizontal hood with grill

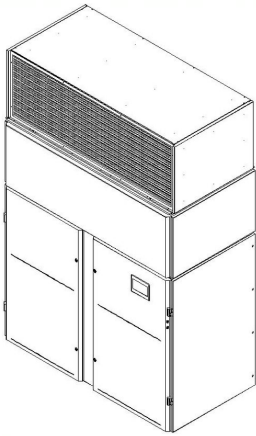

A supply plenum with horizontal air flow can be installed on top of the unit. The 600 mm high plenum shall be the same design as the unit; it should consist of sandwich panels lined with non-flammable insulation material A1 EU class, density 20 kg/m³. It should be equipped with a double deflection grill.

10 - Air economizer

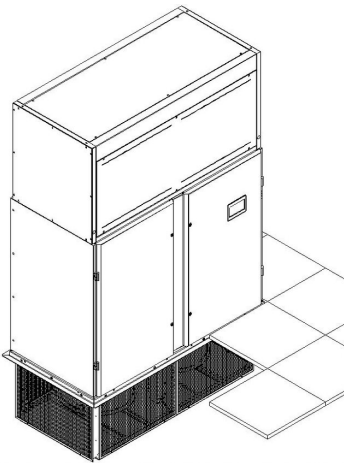

The air economizer is an extension hood with two dampers and two temperature sensors.

A sensor measures the temperature/humidity of the outdoor (**cold**) air. The other sensor measures the temperature of the **warm** air returning to the unit from the room. When the outdoor temperature is low enough the outdoor air is mixed with the room air to adjust the temperature. The two dampers can be placed in different positions (front/back/top), to fit best the room and air ducts layout.

The control checks the external air condition (temperature/humidity) and depending on environment conditions controls the dampers system mixing the indoor unit air with cool outdoor air; it is possible to have 100% outdoor air, mixed outdoor air and compressor cooling or 100% compressor cooling.

The unit shall use only air only if the psychrometric conditions allow this thus reducing wasting of energy humidifying or dehumidifying once they should be not required.

Dampers arrangement

The two dampers can be placed in different positions, to fit best the room and air ducts layout. See below all the possible arrangements.

- Outdoor (**cold**) air
- Room (**warm**) air

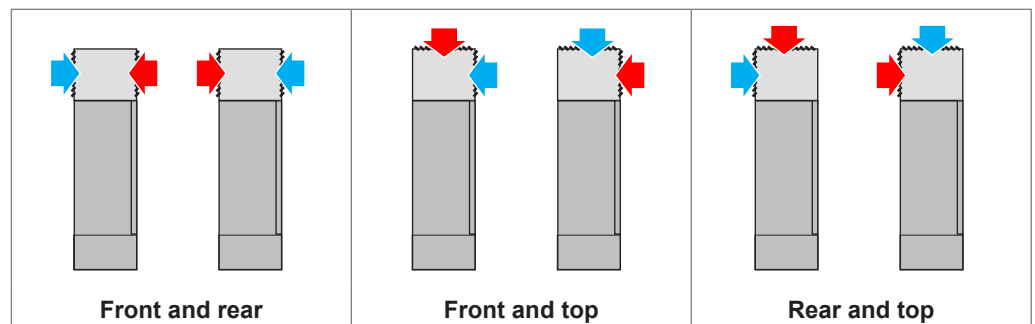

11 - Base module 600/300 mm high with rear air intake

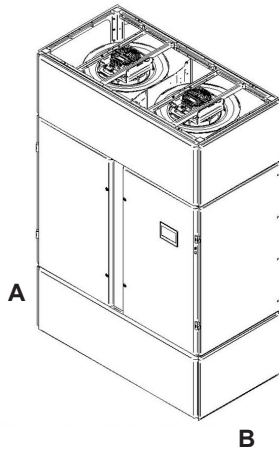

A 600 mm high base module can be supplied on request to support units with upflow air delivery configuration, allowing to work with a rear/bottom air intake and at the same time pipe work to enter from the base of the unit when a raised floor is not installed. Base module shall have same aesthetic design as the unit.

12 - Fresh air module

Upflow

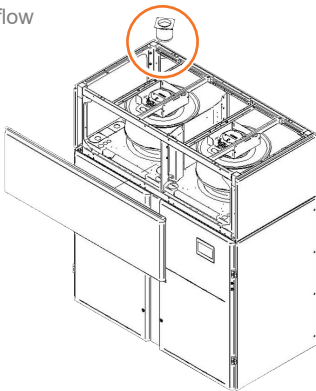

To allow filtered fresh air intake from outdoor. The fresh air is mixed with the recirculation air returning from the room. The kit is made of a G3 class filter with a 100 mm diameter plastic duct.

Downflow

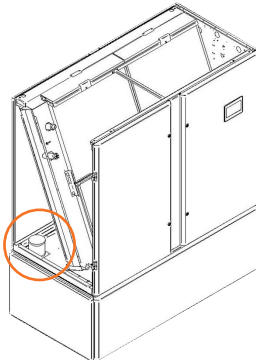

13 - Floor tiles support kit

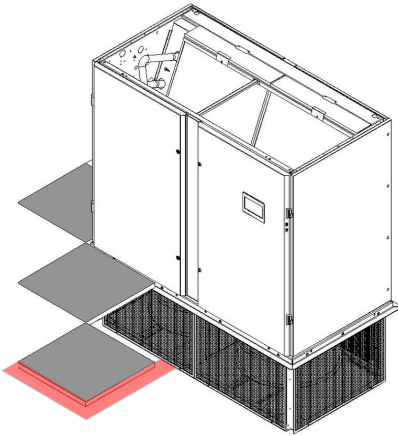

To support the floor tiles around the units when fans are installed in the raised floor. The floor tiles support is fixed on the fan module frame with a thickness of up to 40 mm. With a correct installation, the maximum admitted vertical distributed load on the perimeter is 180 kg/m

14 - Fans maintenance kit

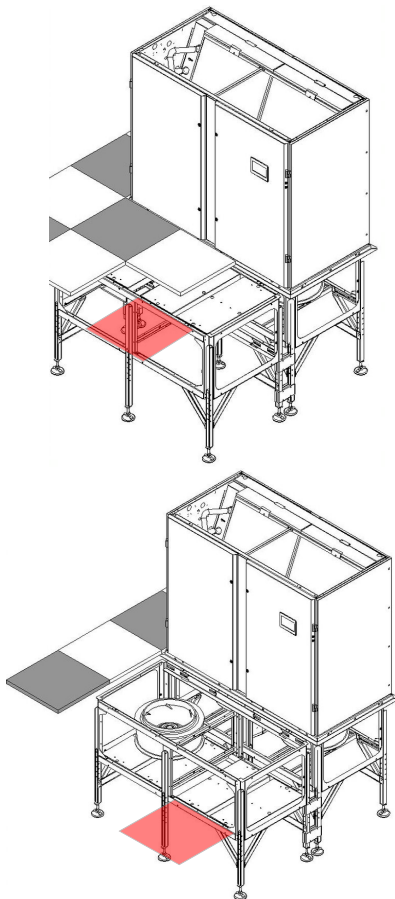

To allow maintenance operations, in particular fan replacement, when the fans are installed below the floor level. Through the removal of tiles on the frontal area, it is possible to lift some footboards, moving them on the lower level, creating a service volume in the raised floor. The footboards are designed to support a maximum vertical distributed load of 600 kg/m² and a maximum concentrated load of 150 kg.

15 - System Display



The system Display is designed for networking multiple units together. All models have a power supply that requires connection to a single phase 230Vac power source with Schuko socket.



Fabbricante - Manufacturer - Hersteller - Fabricant - Fabricante Fabricante - Tillverkare - Fabrikant - Valmistaja - Producent Fabrikant
- Κατασκευαστής - Producent
Vertiv S.r.l. - Zona Industriale Tognana
Via Leonardo da Vinci, 16/18 - 35028 Piove di Sacco - Padova (Italy)

Il Fabricante dichiara che questo prodotto è conforme alle direttive Europee:

The Manufacturer hereby declares that this product conforms to the European Union directives:

Der Hersteller erklärt hiermit, dass dieses Produkt den Anforderungen der Europäischen Richtlinien gerecht wird: Le Fabricant déclare que ce produit est conforme aux directives Européennes:

El Fabricante declara que este producto es conforme a las directivas Europeas:

O Fabricante declara que este produto está em conformidade com as directivas Europeias: Tillverkare försäkrar härmed att denna produkt överensstämmer med Europeiska Unions direktiv: De Fabrikant verklaart dat dit produkt conform de Europese richtlijnen is:

Vaimistaja vakuuttaa täten, että tämä tuote täyttää seuraavien EU-direktiivien vaatimukset: Producent erklærer herved at dette produktet er i samsvar med EU-direktiver:

Fabrikant erklærer herved, at dette produkt opfylder kravene i EU direktiverne:

Ο Κατασκευαστής δηλώνει ότι το προϊόν πλῆρῶν εἶναι Ἀποσῶμασῶνο ἀνῶφωνα με τῆς οἰκονομῆς τῆς Ε.Ε.:

2006/42/EC; 2014/30/EU; 2014/35/EU; 2014/68/EU; 2011/65/EU; EU/2015/863



VertivCo.com | Vertiv - EMEA, via Leonardo Da Vinci 16/18, Zona Industriale Tognana, 35028 Piove di Sacco (PD) Italy, Tel: +39 049 9719 111, Fax: +39 049 5841 257

© 2024 Vertiv Co. All rights reserved. Vertiv, the Vertiv logo and Vertiv Liebert PCW are trademarks or registered trademarks of Vertiv Co. All other names and logos referred to are trade names, trademarks or registered trademarks of their respective owners. While every precaution has been taken to ensure accuracy and completeness herein, Vertiv Co. assumes no responsibility, and disclaims all liability, for damages resulting from use of this information or for any errors or omissions. Specifications are subject to change without notice.

Liebert® PCW - PD - 10015453MAN_ENG - 16.01.2024